

**BO460SS 46 cm  
Multifunction built in oven**

# INSTRUCTION MANUAL

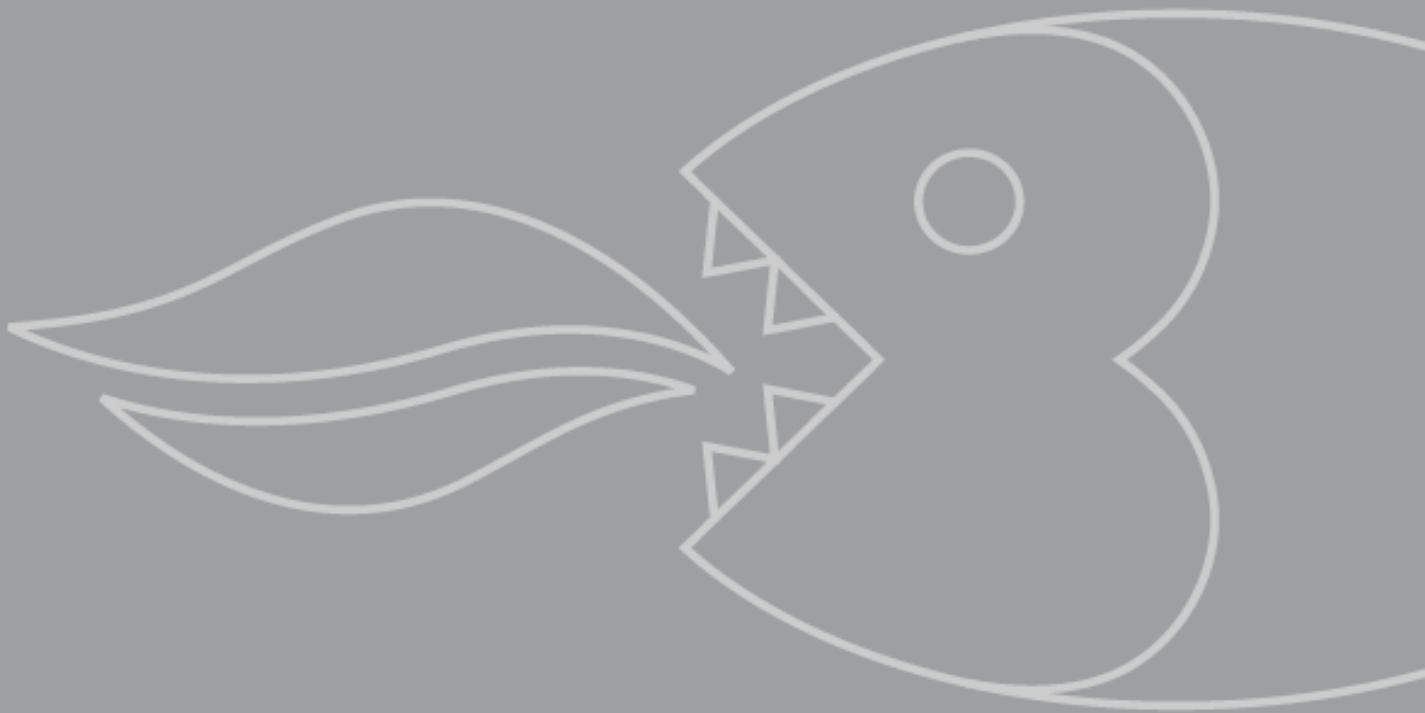

# User Manual for your Baumatic

## BO460SS

46 cm Multifunction built in oven



***NOTE: This User Instruction Manual contains important information, including safety & installation points, which will enable you to get the most out of your appliance. Please keep it in a safe place so that it is easily available for future reference; for you or any person not familiar with the operation of the appliance.***

GS 04/08/11

# Contents

<b>Environmental note</b>	4
<b>Important safety information</b>	5–7
<b>Specifications</b>	8-10
Control panel	10
<b>Setting and using the oven programmer/timer</b>	11-16
Switching on the appliance	11
Setting the time of day	11
Before first use	11-12
Setting the minute minder function	12
Setting the duration function	13
Setting the end cook function	14
Setting the start and end time function	15
Cancelling an automatic function	16
Adjusting the audible signal	16
<b>Selecting a cooking function and temperature</b>	17-22
Switching the oven on and selecting an oven function	17
Oven functions	17-18
Safety lock	18-19
Cooking guidelines	19-20
Warnings	20
Cooking tables	21-22
<b>Cleaning and maintenance</b>	22-25
Removing the side rails for cleaning	23
Removing the oven door for cleaning	24-25
Replacing the oven bulb	25
<b>Installation</b>	26-30
Electrical connection	26
Installing the oven into the kitchen cabinet	27-28
Ventilation requirements	29-30
<b>My appliance isn't working correctly</b>	30-32
<b>Contact details</b>	33

**This appliance is marked according to the European directive 2002/96/EC on Waste electrical and Electronic Equipment (WEEE). By ensuring this product is disposed of correctly, you will help prevent potential negative consequences for the environment and human health, which could otherwise be caused by inappropriate waste handling of this product.**

The symbol  on the product, or on the documents accompanying the product, indicates that this appliance may not be treated as household waste. Instead it shall be handed over to the applicable collection point for the recycling of electrical and electronic equipment.

**Disposal must be carried out in accordance with local environmental regulations for waste disposal.**

**For more detailed information about treatment, recovery and recycling of this product, please contact your local city office, your household waste disposal service or the shop where you purchased the product.**



- The packaging materials that Baumatic uses are environmentally friendly and can be recycled.
- Please discard all packaging material with due regard for the environment.

## IMPORTANT SAFETY INFORMATION



Your safety is of the utmost importance to Baumatic. Please make sure that you read this instruction booklet **before** attempting to install or use the appliance. If you are unsure of any of the information contained in this booklet, please contact the Baumatic Advice Line.

### General Information

- This appliance is designed for domestic household use and can be built into a standard kitchen cabinet or housing unit.
- **IMPORTANT:** *The adjacent furniture or housing and all materials used in the installation **must** be able to withstand a minimum temperature of 85°C above the ambient temperature of the room it is located in, whilst in use.*
- Certain types of vinyl or laminate kitchen furniture are particularly prone to heat damage or discolouration at temperatures below the guidelines given above.
- Any damage caused by the appliance being installed in contravention of this temperature limit, or by placing adjacent cabinet materials closer than 4mm to the appliance, **will be the liability of the owner.**
- For use in **leisure accommodation vehicles**, please refer to the appropriate information given in the installation instructions for this appliance.
- The use of this appliance for any other purpose or in any other environment without the express agreement of Baumatic Ltd. will invalidate any warranty or liability claim.
- Your new appliance is guaranteed against electrical or mechanical defects, subject to certain exclusions that are noted in Baumatic's Conditions Of Guarantee. The foregoing does not affect your statutory rights.
- **Repairs may only be carried out by Baumatic Service Engineers or their authorised service agent.**

## Warning and safety instructions

- This appliance complies with all current European safety legislation. Baumatic do wish to emphasise that this compliance does not remove the fact that the appliance surfaces ***will become hot during use and retain heat after operation.***

## Child Safety

- Baumatic strongly recommend that babies and young children are prevented from being near to the appliance and not allowed to touch the appliance ***at any time.***
- If it is necessary for younger family members to be in the kitchen, please ensure that they are kept under close supervision at all times.

## General Safety

- ***Do not*** place heavy objects on the oven door or lean on the oven door when it is open, as this can cause damage to the oven door hinges.
- ***Do not*** leave heated oil or fat unattended, as this is a fire risk.
- ***Do not*** place pans or baking trays directly on the base of the oven cavity, or line it with aluminium foil.
- ***Do not*** allow electrical fittings or cables to come into contact with areas on the appliance that get hot.
- ***Do not*** use the appliance to heat the room it is located in or to dry clothing.
- ***Do not*** install the appliance next to curtains or soft furnishings.
- ***Do not*** attempt to lift or move cooking appliances by using the oven door or handle, as this may cause damage to the appliance or result in injury to the person lifting the appliance.

## Cleaning

- Cleaning of the oven should be carried out on a regular basis.
- Great care should be taken whilst using this appliance and when following the cleaning procedure.

- **IMPORTANT:** *The appliance must be disconnected from the mains before following the cleaning procedure.*

## Installation



***This appliance must be correctly installed by a suitably qualified person, strictly in accordance with the manufacturer's instructions.***

- ***Baumatic Ltd. declines any responsibility for injury or damage, to person or property, as a result of improper use or installation of this appliance.***
- Heat, steam and moisture will be created during use of the appliance, take care to avoid injury and ensure that the room is adequately ventilated. If the appliance is going to be used for prolonged periods of time, then additional ventilation may be required.
- Please consult with your qualified installer if you are in any doubt about the amount of ventilation that you will require.

## Declaration of conformity

This appliance complies with the following European Directives:

- 2006/95/EC regarding "low voltage"
- 2004/108/EC regarding "electromagnetic disturbances"
- Regulation (EC) N° 1935/2004 regarding "materials in contact with food"
- The above directives comply with 93/68/EEC regarding CE marking.
- The manufacturer declares that the oven is built using certified materials and requires the appliance to be installed in accordance with the standards currently in force. This appliance must be used by a trained person for domestic purposes only.

# Specifications

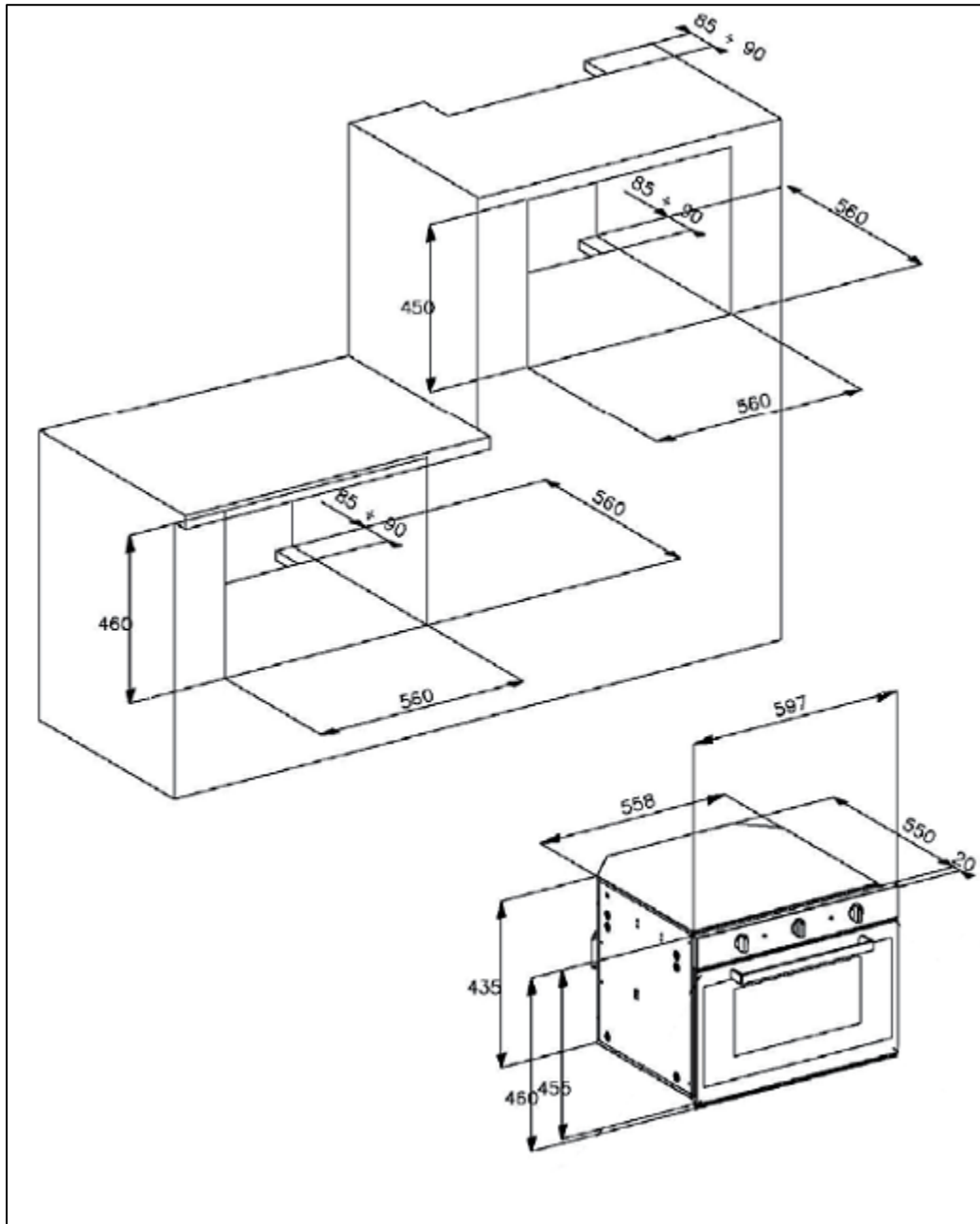

## Product Dimensions

Height: 460 mm  
Width: 597 mm  
Depth: 570 mm

## Aperture Dimensions

Height: 460 mm (built under) / 450 mm (built in)  
Width: 560 mm  
Depth: 560 mm



## Specifications

- 10 oven functions
- Energy efficiency class: A
- Gross oven capacity: 45 litres
- Net oven capacity: 37 litres
- LED full programmer
- Oven light
- Cooling fan
- Thermostatically controlled grill
- Triple-glazed removable door
- Safety lock

## Standard accessories

- Removable chrome side racks
- 1 x Safety shelf
- 1 x Enamelled baking tray with handle
- 1 x Trivet
- 1 x Telescopic runners (1 level)

## Optional extra

- BPS2 Pizza stone

## Energy efficiency class: A

## Electrical details

<b><i>Rated Voltage:</i></b>	220 - 240 Vac 50 - 60 Hz
<b><i>Supply Connection:</i></b>	16 A (double pole switched fused outlet with 3mm contact gap)
<b><i>Max Rated Inputs:</i></b>	3.36 kW
<b><i>Mains Supply Lead:</i></b>	3 x 1.5 mm <sup>2</sup>
<b><i>Oven Light Bulb:</i></b>	25 W/300°C screw type pygmy

For future reference please record the following information which can be found on the rating plate and the date of purchase which can be found on your sales invoice. The rating plate for your oven can be located by opening the oven door and looking on the right hand side of the oven chassis.

***Model Number*** .....

***Serial Number*** .....

**Control Panel**

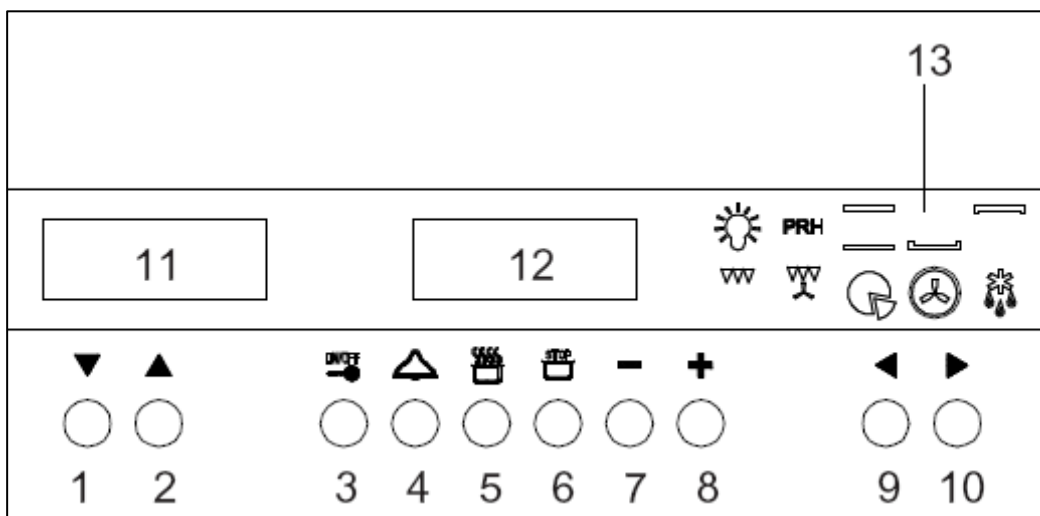

- 1) Temperature increase button
- 2) Temperature decrease button
- 3) ON / OFF button
- 4) Minute minder button
- 5) Cooking time button
- 6) End of cooking time button
- 7) Timer minus button
- 8) Timer plus button
- 9) Cooking program left scroll button
- 10) Cooking program right scroll button
- 11) Temperature display
- 12) Timer display
- 13) Cooking function LED display

**Display symbols**



This symbol indicates that the minute minder function is in use. If the symbol is flashing, it means the cooking program has ended.



This symbol lights up when a cooking function is in use except the pre-heating and defrosting programs. When the symbol is flashing, it means the cooking time has ended.

**A** = This symbol lights up when a cooking time has been set. If the symbol is flashing, it means the end of a cooking program has been reached.

## Setting and using the oven programmer/timer

### Switching on the appliance

***After your appliance is connected to your mains supply for the first time, the numbers on the timer display will flash. Before you can select a cooking function or set a temperature, you must set the time of day.***

- Press the ON / OFF button **(3)** to turn the oven on. A sound will be heard and the timer display will show "ON". The bulb symbol lights on the display and the internal oven light turns on.

### Setting the time of day

***After setting your oven for manual operation, you should also set the time of day.***

- Press the cooking time button **(5)** and the end of cooking time button **(6)** simultaneously. The two dots on the timer display **(12)** will flash.
- Within 3 seconds of releasing the buttons, use the timer plus **(8)** and minus **(7)** buttons until the correct hour is selected.
- Once you have released either the plus or minus buttons, after 3 seconds the two dots on the timer display will stop flashing and the time of day will be set.

***IMPORTANT: When the oven is switched off, the clock's luminous intensity decreases. By touching any key, the clock returns to maximum luminosity for 60 seconds.***

### Before first use

- To remove any residue from the oven that may have been left from the manufacturing process, you should select the fan oven function and set the thermostat to its maximum temperature setting.
- It is perfectly normal for a smell to be produced during this process.
- You should make sure that any windows in the room are left open during this process.
- It is advisable for you not to remain in the room whilst the burning off process is taking place.

- You should leave the oven on maximum setting for 30 – 40 minutes.
- After the oven cavity has cooled, it should then be cleaned with warm soapy water, using either a sponge or soft cloth. No abrasive cleaners should be used.
- Outer parts of the oven should be cleaned with warm soapy water, using either a sponge or soft cloth. No abrasive cleaners should be used.
- We would recommend that an appropriate stainless steel cleaner and polish is regularly used on the stainless steel surfaces of this appliance.

### **Setting the minute minder function**

***You are able to set the minute minder, regardless of whether an oven function has been selected. You can set a period of time using the minute minder function and an alarm will sound when this period of time has elapsed.***

- Press and release the ON/OFF button **(3)** and you will hear an audible signal. The timer display will show the word ON, the bulb symbol will light and the internal oven light will come on.
- Press the minute minder button **(4)** and the timer display will reset to zero and two dots will start flashing.
- Within 3 seconds press the timer plus **(8)** and minus **(7)** buttons to set the countdown period that you require. You can set any length of time up to 23hr59min.
- Once you have released either the plus or minus buttons, after 3 seconds the two dots on the timer display **(12)** will stop flashing.
- When the countdown period has elapsed, an audible signal will sound and the bell symbol will flash on the timer display **(12)**. To turn off the audible signal and return the oven to manual operation, press any of the timer buttons (apart from the ON/OFF button).
- ***Important:*** *The oven will continue to heat once the audible signal has been silenced. If you have finished cooking, then you switch the oven off, using the ON/OFF button.*

## Setting the duration function

*This function will allow you to set a countdown time similar to the minute minder function. However the oven will no longer continue to heat, once the countdown period has elapsed.*

- Press and release the ON/OFF button **(3)** and you will hear an audible signal. The timer display will show the word ON, the bulb symbol will light and the internal oven light will come on.
- Press and release the cooking time button **(5)**, on the timer display an "A" symbol will appear. Within 3 seconds press the timer plus **(8)** and minus **(7)** buttons to select the required cooking time. The maximum cooking period that you can select is 10 hours.
- After releasing the plus and minus buttons, wait until you hear an audible signal and the timer display again shows the current time.
- Use the oven function selector buttons **(9)** and **(10)** to choose the cooking function that you want to use. The cooking function lights will show which function you have currently selected. The pot symbol will appear on the timer display.
- The oven will suggest a preset cooking temperature; however it is possible to adjust the temperature by using the temperature selection buttons **(1)** and **(2)**.
- At the end of the set time period, an audible signal will sound; the temperature display and the cooking function light will switch off. The timer display will show the current time, the pot and "A" symbols will flash. The oven will no longer heat.
- To turn off the audible signal and return the oven to manual operation, press any of the timer buttons (apart from the ON/OFF button). The timer display will show the word ON, the bulb symbol will light and the internal oven light will come on. You can then select a new cooking function or switch the oven off using the ON/OFF button.

## Setting the end cook function

*This function is similar to the duration function, however instead of selecting a period of time that you wish the oven to switch off after. You select the time of day that you wish the oven to switch off at.*

- Press and release the ON/OFF button **(3)** and you will hear an audible signal. The timer display will show the word ON, the bulb symbol will light and the internal oven light will come on.
- Press and release the end of cooking time button **(6)**, on the timer display and the "A" symbol will appear. Within 3 seconds press the timer plus **(8)** and minus **(7)** buttons to select the time of day that you want the oven to switch off at.
- After releasing the plus and minus buttons, wait until you hear an audible signal and the timer display again shows the current time.
- Use the oven function selector buttons **(9)** and **(10)** to choose the cooking function that you want to use. The cooking function lights will show which function you have currently selected. The pot symbol will appear on the timer display.
- The oven will suggest a preset cooking temperature; however it is possible to adjust the temperature by using the temperature selection buttons **(1)** and **(2)**.
- When the time of day that you set the oven to switch off at has been reached, an audible signal will sound; the temperature display and the cooking function light will switch off. The timer display will show the current time, the pot and "A" symbols will flash. The oven will no longer heat.
- To turn off the audible signal and return the oven to manual operation, press any of the timer buttons (apart from the ON/OFF button). The timer display will show the word ON, the bulb symbol will light and the internal oven light will come on. You can then select a new cooking function or to switch the oven off using the ON/OFF button.

## Setting the start and end time function

***This function will allow you to set a time in the future that the oven switches on at and a time that the oven will switch off at.***

- Press and release the ON/OFF button **(3)** and you will hear an audible signal. The timer display will show the word ON, the bulb symbol will light and the internal oven light will come on.
- Press and release the cooking time selection button **(5)**, on the timer display and the "A" symbol will appear. Within 3 seconds press the timer plus **(8)** and minus **(7)** buttons to select the length of time that you want the oven to cook for.
- An audible signal will sound and the timer display will show the current time. Press the end of cooking time button **(6)** and within 3 seconds press the timer plus **(8)** and minus **(7)** buttons to select the time of day that you want the oven to switch off at. After releasing these buttons the audible signal will sound again and the two dots on the timer display will stop blinking.
- Use the oven function selector buttons **(9)** and **(10)** to choose the cooking function that you want to use. The cooking function lights will show which function you have currently selected. The pot symbol will appear on the timer display.
- The oven will suggest a preset cooking temperature; however it is possible to adjust the temperature by using the temperature selection buttons **(1)** and **(2)**.
- The oven will automatically work out the time that it needs to switch on at. When it is cooking, you can adjust the oven temperature and cooking function by pressing the relevant buttons.
- When the time of day that you set the oven to switch off at has been reached, an audible signal will sound; the temperature display and the cooking function light will switch off. The timer display will show the current time, the pot and "A" symbols will flash. The oven will no longer heat.
- To turn off the audible signal and return the oven to manual operation, press any of the timer buttons (apart from the ON/OFF button). The timer display will show the word ON, the bulb symbol will light and the internal oven light will come on. You can then select a new cooking function or to switch the oven off using the ON/OFF button.

## Cancelling an automatic cooking function

***If an automatic cooking function has been set and you wish to use the oven in manual operation mode, you will need to cancel the automatic cooking function.***

- To select manual operation mode, press the cooking time selection button **(5)** and end of cooking time button **(6)** simultaneously.
- The oven will continue to heat on the cooking function and oven temperature that was previously selected.
- You can select a different cooking function and oven temperature by using the relevant buttons. Or you can switch the oven off by pressing the ON/OFF button.

***IMPORTANT: It is not possible to use any of the timer functions (apart from the minute minder) with the defrost or preheat oven functions.***

## Adjusting the audible signal

- The audible signal has three different settings, low, medium and high.
- To adjust the level of the audible signal, make sure that the timer is in manual mode. Then press and hold the minus button and you will hear the current level that is set.
- Press the minus button again and the audible signal will adjust to the next level.
- When the required level of audible signal is reached, release the minus button and it will be set.



## Selecting a cooking function and temperature

### Switching the oven on and selecting an oven function

- Press and release the ON/OFF button **(3)** and you will hear an audible signal. The timer display will show the word ON, the bulb symbol will light and the internal oven light will come on.
- Use the oven function selector buttons **(9)** and **(10)** to choose the cooking function that you want to use. The cooking function lights will show which function you have currently selected. The pot symbol will appear on the timer display.
- The oven will suggest a preset cooking temperature; however it is possible to adjust the temperature by using the temperature selection buttons **(1)** and **(2)**.
- When selecting an oven function, the oven cavity light will turn on.
- The oven will start to heat and a centigrade degree symbol (°) will flash in the temperature display.
- When the oven temperature that you have selected has been reached the (°) symbol will stop flashing and the oven will beep.
- ***You should not place food inside the cavity, until the correct cooking temperature has been reached.***

There are ten functions available on your appliance:

#### 10 oven functions

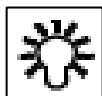

**OVEN LIGHT:** The oven cavity light will switch on when the oven is switched on. It will remain on whilst the oven is heating to the selected temperature and for a further three minutes once the desired temperature has been reached. To turn the oven light on again, press any of the timer buttons (apart from the ON/OFF button). The light will then switch on for 1 minute.

**PRH PREHEATING:** This function uses the grill, lower element and fan. It is intended for preheating the oven in a faster time to 210°C.

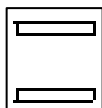

**CONVENTIONAL OVEN (top and lower element):** This method of cooking provides traditional cooking, with heat from the top and lower elements. This function is suitable for roasting and baking on one shelf only.

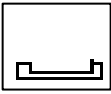

**LOWER ELEMENT ONLY:** This method of cooking uses the lower element to direct heat upward to the food. This function is suitable for slow-cooking recipes or for warming up meals.

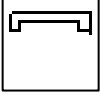

**UPPER ELEMENT ONLY:** This method of cooking uses the outer part of the top element to direct heat downwards onto the food. This function is suitable for gentle cooking, browning or keeping cooked dishes warm.

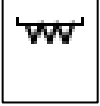

**GRILL MODE:** This method of cooking utilises the top element, which directs heat downwards onto the food. This function is suitable for grilling portions of bacon, toast and meat etc.

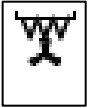

**FAN AND GRILL:** This method of cooking utilises the top element in conjunction with the fan, which helps to provide a quick circulation of heat. This function is suitable where quick browning is required and “sealing” the juices in, such as steaks, hamburgers, some vegetables etc.



**PIZZA FUNCTION:** This method of cooking uses the lower and circular element while the heat is distributed by the fan, reproducing the same conditions of traditional clay wood-fire stoves.



**FAN OVEN:** This method of cooking uses the circular element while the heat is distributed by the fan. This results in a faster and more economical cooking process. The fan oven allows food to be cooked simultaneously on different shelves, preventing the transmission of smells and tastes from one dish onto another.



**DEFROST MODE:** The fan runs without heat to reduce the defrosting time of frozen foods. The time required to defrost the food will depend on the room temperature, the quantity and type of food. Always check food packaging for the defrosting instructions.

## Safety lock

- This function can be enabled at any time to prevent unauthorised operation of the oven.
- If this function is enabled when the oven is turned off, it will not be possible to switch the oven on without removing the lock.
- To enable the locking function, hold down the ON / OFF button **(3)** until the display shows the control lock symbol, followed by the word ON and then the display will show the current hour.

***IMPORTANT: Once the safety lock is activated, it is not possible to set any program or cooking function, except for the minute minder. If the lock is enabled after a program has been set, it will only be possible to set the minute minder or switch off the oven using the ON / OFF button.***

- By touching any other key, the display will show the safety lock icon to indicate the function is active.
- The automatic or manual switching off of the oven will not disable the locking function.
- To disable the locking function, hold down the ON / OFF button **(3)** until the safety lock icon appears on the display, followed by the word OFF and then the display will return to the current time.
- When the safety lock is enabled, it is not possible to switch the oven on with the ON / OFF button but only to switch it off.

### **Cooking guidelines**

- Please refer to the information given on food packaging for guidance on cooking temperatures and times. Once familiar with the performance of your appliance, temperatures and times can be varied to suit personal preference.
- If you are using the fan oven function, then you should follow the information given on the food packaging for this particular mode of cooking.
- You should pre-heat the oven and not place food inside of it until the oven operating light has gone off. You can choose not to pre-heat when using the fan oven mode; however you should extend the cooking time given on the food packaging by at least ten minutes.
- ***IMPORTANT: You should pre-heat the oven if you are baking no matter what oven function you are using.***
- If there is no guidance given on the food packaging specifically for cooking in fan oven mode, you can generally reduce the cooking time and temperature by 10% from the information given for conventional oven cooking.
- Make sure that frozen foods are thoroughly thawed before cooking, unless the instructions on the food packaging advise that you can “cook from frozen”.





- Before cooking, check that any accessories that are not required are removed from the oven.
- Place cooking trays in the centre of the oven and leave gaps between the trays to allow air to circulate.
- Try to open the door as little as possible to view the dishes.
- The oven light will remain on during cooking.

## Warnings

- Keep the oven door closed when using any of the grill functions.
- Do not use aluminium foil to cover the grill pan or heat items wrapped in aluminium foil under the grill. The high reflectivity of the foil could potentially damage the grill element.
- You should also never line the base of your oven with aluminium foil.
- During cooking, never place pans or cookware directly onto the bottom of your oven. They should always be placed on the shelves provided.
- The grill heating element and other internal components of the oven become extremely hot during operation, avoid touching them inadvertently when handling the food which you are grilling.
- **Important:** *Be careful when opening the door, to avoid contact with hot parts of the oven and steam.*
- The drip tray handle should only be used to reposition the drip tray and **NOT** for removing it from the oven cavity. When removing the drip tray, you should **ALWAYS** use an oven glove.
- The drip tray handle should not be left in position when the appliance is switched on.
- **Warning:** *Accessible parts may become hot during use. Young children should be kept well away from the oven when it is in use.*

## Cooking tables

- The information provided below is approximate. Cooking times vary based on the amount and quality of the foods.
- The cooking times do not include pre-heating. It is recommended that you pre-heat the oven for about 15 minutes.

<i>Type of dish</i>	<i>Temperature °C</i>	<i>Cooking time (minutes)</i>	<i>Level (from bottom)</i>	<i>Oven function (select one)</i>
<b>Bread and biscuits</b>				
Pizza	220	20/30	1	
Bread	190/200	45/60	1	
Bread with filling	150/160	20/25	1 or 2	
White bread	175/210	25/40	1 or 2	
Biscuits	140/150	20/30	1/2	
<b>Pie and pastry</b>				
Focaccia	175	40/45	2	
Sponge cake	190	25/35	2	
Chocolate cake	175	30/40	2	
Fruit pie	140	50/70	2	
Vol-au-vent	175	20	2	
Doughnut	180	35/45	2	
Angel cake	150	20/25	2	
Souffle	180/200	20/30	2	
Meringue	120/125	23/35	2	
<b>Meat</b>				
Veal stew (1/1.5 kg)	150/160	180/210	1 or 2	
Roast veal (1/1.5 kg)	150/160	120/150	1 or 2	
Meat loaf (1/1.5 kg)	180/190	90/120	1 or 2	
Lamb (leg or chop)	180/190	60/90	1 or 2	
Beef (leg or chop)	180	45/60	1 or 2	
Pork (loin or leg)	180	60/90	2	
<b>Game</b>				
Roast pheasant	180	60/90	1 or 2	
Venison	175	90/120	1 or 2	
<b>Poultry</b>				
Chicken	170	90/120	1 or 2	
Duck	175	180/200	1	
<b>Fish</b>				
Fish in general	200	15/20	2	

- Depending on the type of food for example meats fish and poultry, you will need to turn the food to expose both sides to the infrared rays.

- With the ventilated grill function, do not select a temperature of more than 190°C.

<i><b>Foods to be grilled</b></i>	<i><b>Cooking time in minutes</b></i>	
	Over	Under
Cuts of thin meat	6	4
Cuts of normal meat	8	5
Fish (trout, salmon etc)	15	12
Sausages	12	10
Toast	5	2

## Cleaning and maintenance



***Cleaning operations must only be carried out when the oven is cool.***

***The appliance should be disconnected from your mains supply before commencing any cleaning process.***

- The oven should be thoroughly cleaned before it is operated for the first time and after each use. This will avoid residual food stuffs becoming baked on the oven cavity. After residues have been baked on several times, they are far more difficult to remove.
- **Never** clean the oven surfaces by steam cleaning.
- The oven cavity should only be cleaned with warm soapy water, using either a sponge or soft cloth. No abrasive cleaners should be used.
- Any stains that may appear on the bottom of the oven will have originated from food splashes or spilt food, these splashes occur during the cooking process. These could possibly be a result of the food being cooked at an excessively high temperature or being placed in cookware that is too small.
- You should make sure that the cooking temperature that is selected is appropriate for the food that you are cooking. You should also ensure that the food is placed in an adequately sized dish and use the drip tray where appropriate.
- Outer parts of the oven should only be cleaned with warm soapy water, using either a sponge or soft cloth. No abrasive cleaners should be used.

- If you use any form of oven cleaner on your appliance, then you must check with the manufacturer of the cleaner that it is suitable for use on your appliance.
- ***Any damage that is caused to the appliance by a cleaning product will not be fixed by Baumatic free of charge, even if the appliance is within the guarantee period.***

### Removing the side rails for cleaning

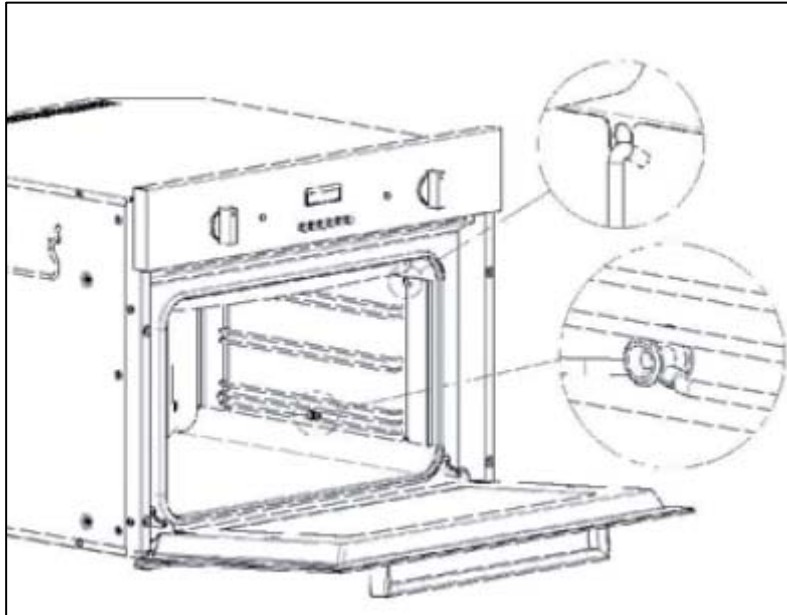

- The side rails are hooked onto the wall of the oven. The shelf provided slides into the side rails. To remove the side rails take out all shelves and trays and press on the release catch as shown above.

## Removing the oven door for cleaning

To facilitate the cleaning of the inside of the oven and the outer frame of the oven, the door can be removed as follows: -

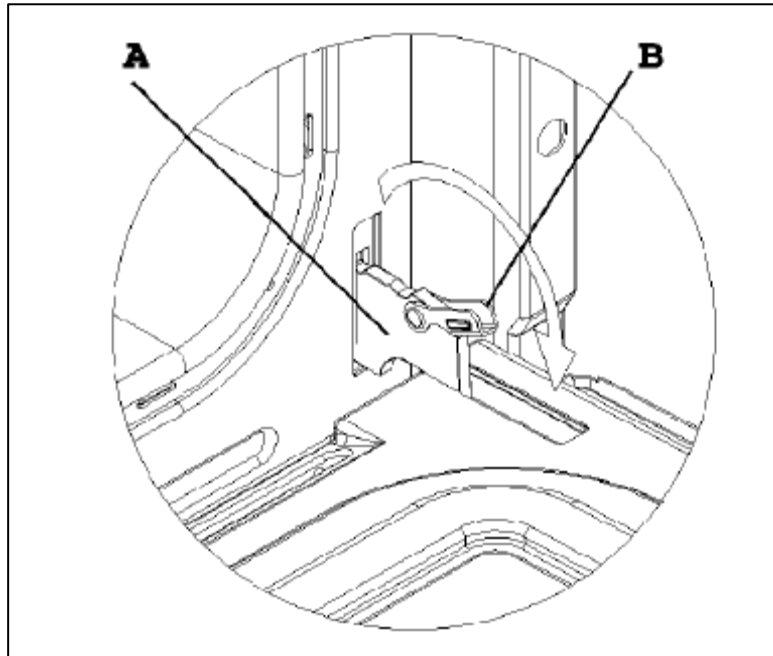

- The hinges **(A)** have two movable bolts on them **(B)**.
- If you raise both of the movable bolts **(B)**, then the hinges **(A)** are released from the oven housing.
- You should grip the sides of the door at the centre and then incline it slightly towards the oven cavity and then by pulling it gently away from the oven cavity. **WARNING- Care should be taken as the inner edges of the door may be sharp.**
- **IMPORTANT:** You should make sure that the door is supported at all times and that you place the door on some padded material whilst cleaning it.
- The oven door and door glass should only be cleaned using a damp cloth and a small amount of detergent. The cloth **MUST NOT** have come into contact with any form of cleaning product or chemical previously.
- To refit the door you should slide the hinges back into their slots and open the door fully.
- **IMPORTANT:** The movable bolts **(B)** must be closed back into their original positions before closing the door.





- *Take care not to dislodge the hinge locking system when removing the door, as the hinge mechanism has a strong spring.*
- *Do not immerse the door in water at any time.*

### Replacing the oven bulb



**IMPORTANT:** *The oven must be disconnected from your mains supply before you attempt to either remove or replace the oven bulb.*

- Remove all oven shelves, the drip tray and the side rack that is on the same side as the oven light.

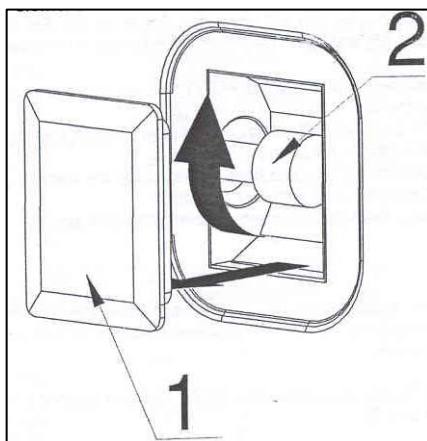
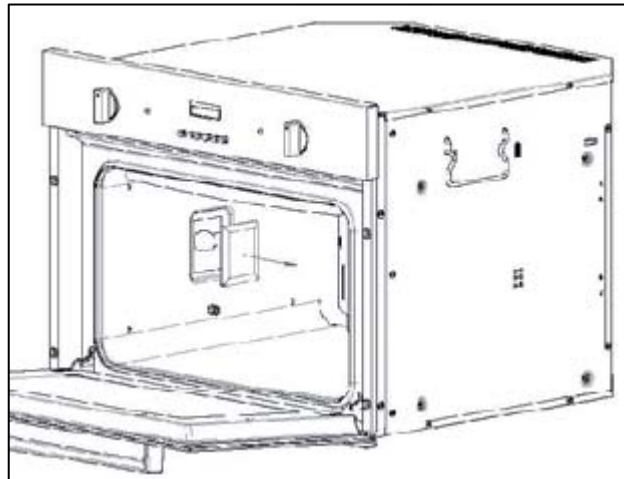

- Using a screwdriver, remove the lamp cover **(1)**.
  - Unscrew the bulb clockwise and remove it from its holder **(2)**.
  - Replace the bulb with a 25 W/300°C, screw type pygmy.
  - **Do not** use any other type of bulb.
- Place the lamp cover back into position.

## INSTALLATION



*The installation must be carried out by a suitably qualified person, in accordance with the current version of the following.*

- UK Regulations and Safety Standards or their European Norm Replacements.
- ***Building Regulations*** (issued by the Department of the Environment).
- ***Building Standards*** (issued by the Scottish Development Department).
- ***IEE Wiring Regulations***.
- ***Electricity At Work Regulations***.

Before connecting the appliance, make sure that the supply voltage marked on the rating plate corresponds with your mains supply voltage.

### ***WARNING: THIS APPLIANCE MUST BE EARTHED.***

- This appliance should be wired into a 16 A double pole switched fused spur outlet, having 3 mm contact separation and placed in an easily accessible position adjacent to the appliance. The spur outlet must still be accessible even when your oven is located in its housing.

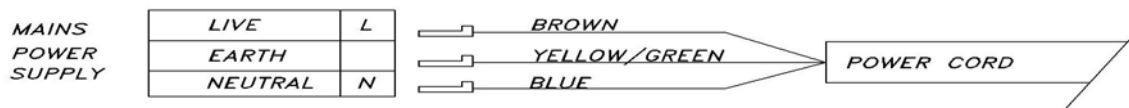

- To connect the oven power cord, loosen and remove the cover on the terminal block, in order to gain access to the contacts inside. Make the connection, securing the cord in place with the cable clamp provided and then immediately close the terminal block cover again.
- If you have to change the oven power cord, the earthing (yellow/green) conductor must always be 10 mm longer than the line conductors.
- Care must be taken to ensure that the temperature of the mains supply cable does not exceed 50°C.
- If the mains supply cable is damaged, then it must be replaced by an appropriate replacement which can be obtained from the Baumatic Spares Department.

## Installing the oven into the kitchen cabinet

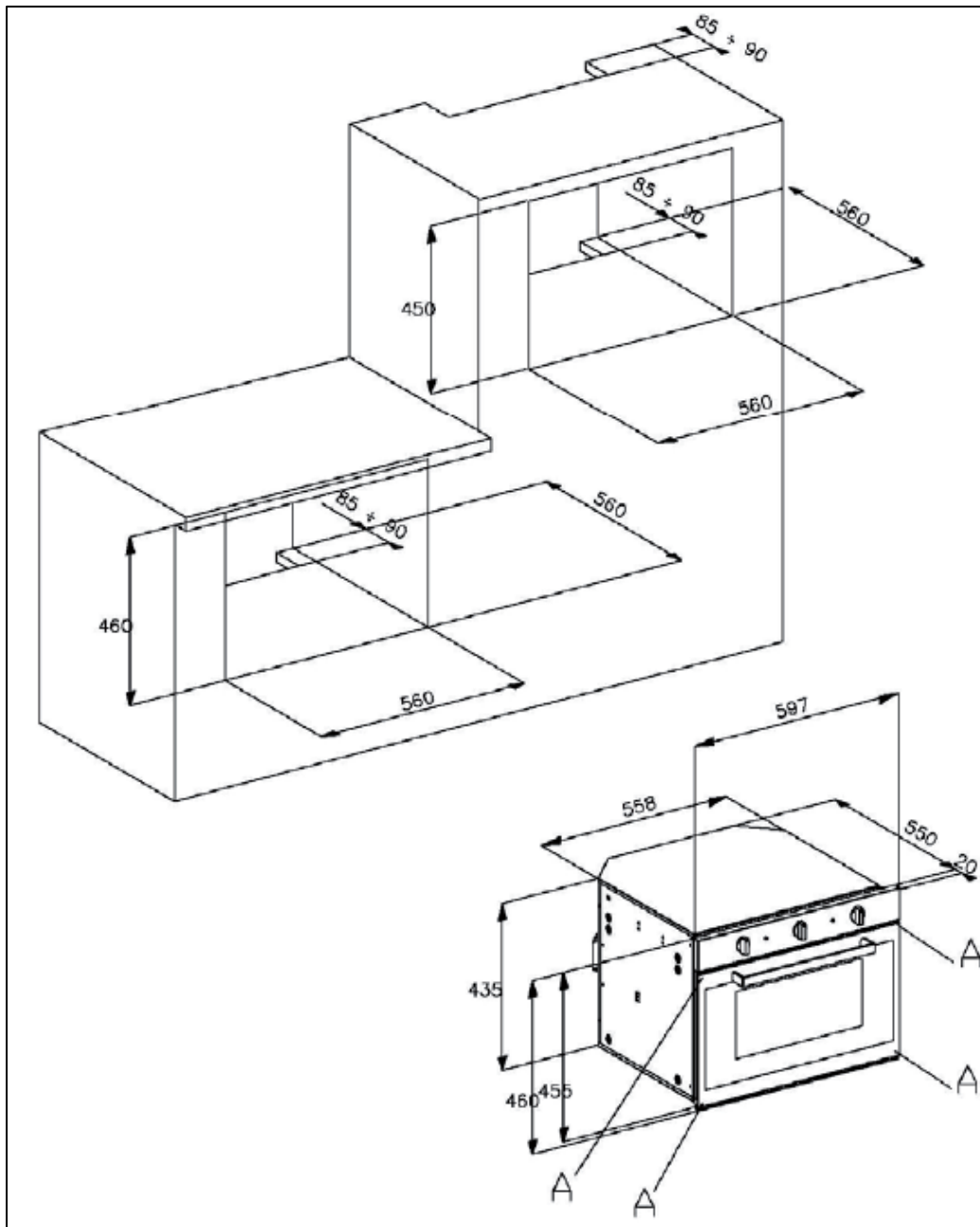

### Positioning the appliance

- Ensure that the aperture that you will be fitting the oven into is of the size given in the above diagrams.
- The oven must be fitted into an oven housing with the ventilation cut-outs shown in the "Ventilation requirements" section on the next page.
- Ensure that the rear panel of the furniture housing unit has been removed.

### Built under installation

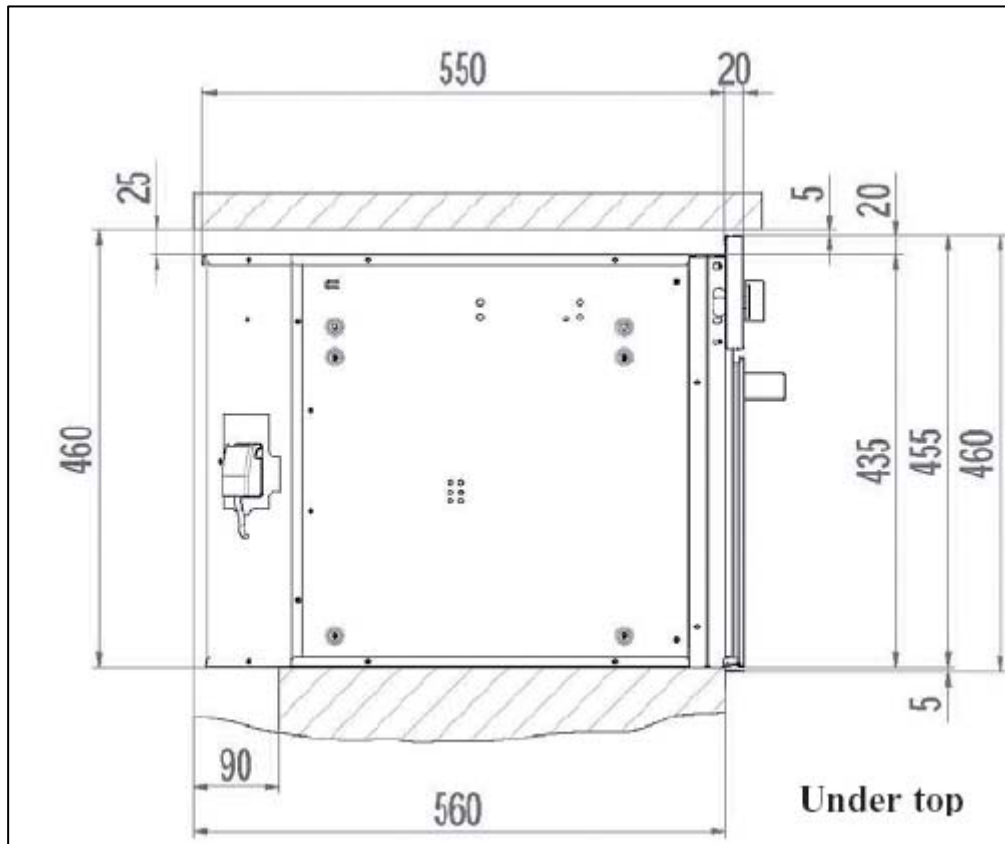

### Built in installation

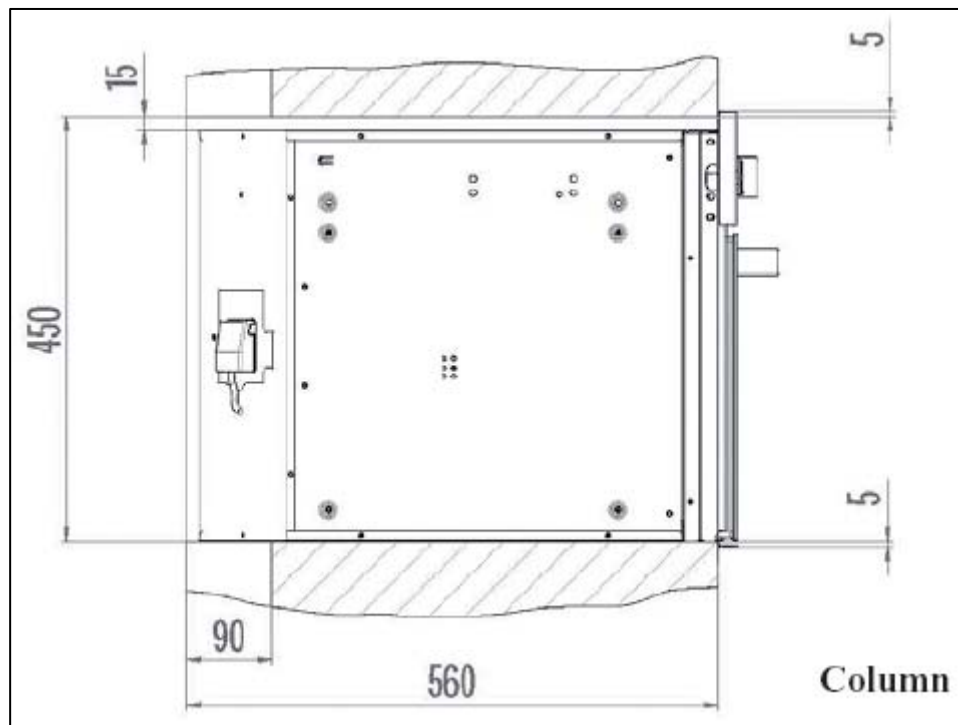

## Ventilation requirements

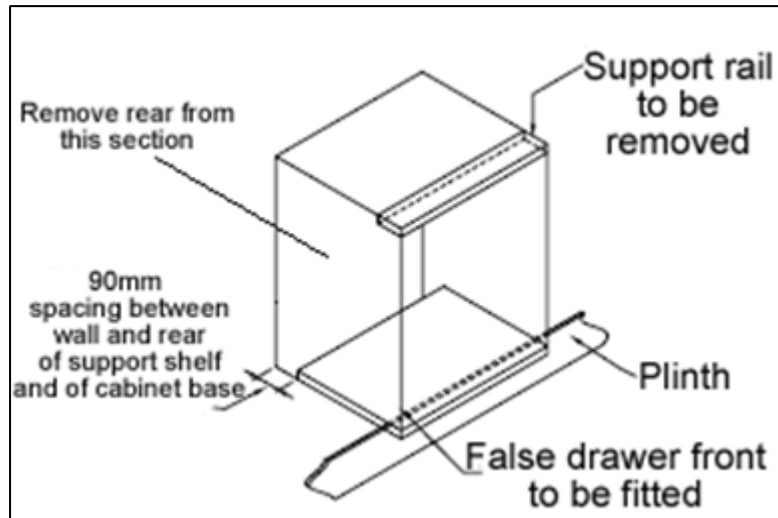

(Figure shows the ventilation and cut-out requirements for the installation of the appliance into a standard kitchen unit).

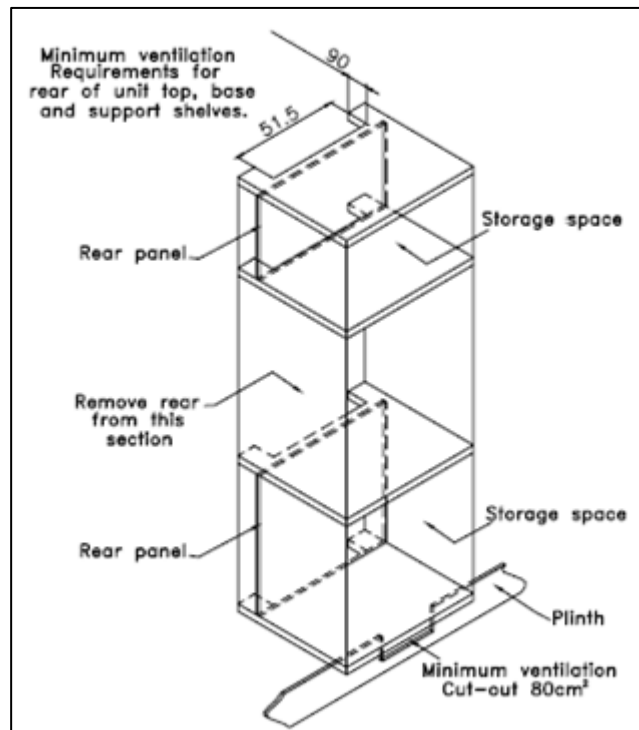

(Figure shows the ventilation and cut-out requirements for the installation of the appliance into a tall housing unit).

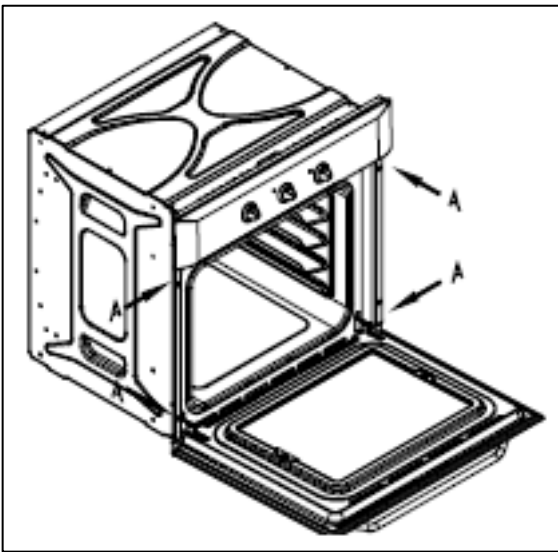

Ensure that the oven has been securely fixed into the housing unit. The fixing of the oven into the housing is made by using four screws. These should be screwed through the oven cabinet and into the housing

### **My appliance isn't working correctly**

- ***The oven isn't coming on.***
  - \* Check that the oven is in manual operation mode.
  - \* Check that you have selected a cooking function and a cooking temperature.
- ***There appears to be no power to the oven and grill.***
  - \* Check that the appliance has been connected to the electrical mains supply correctly.
  - \* Check that the mains fuses are in working order.
  - \* Check that the operating instructions for setting the time of day and putting the appliance into manual operation mode have been followed.
- ***The grill function works but the main oven does not.***
  - \* Check that you have selected the correct cooking function.
- ***The grill and top oven element is not working, or cuts out for long periods of time during use.***
  - \* Allow the oven to cool for approximately 2 hours. Once cool, check whether the appliance is again working properly.

- ***My food is not cooking properly***
  - \* Ensure that you are selecting the correct temperature and the correct cooking function for the food that you are cooking. It may be appropriate to adjust your cooking temperature by plus or minus 10°C, to achieve the best cooking results.
- ***My food is not cooking evenly***
  - \* Check that the oven has been installed correctly and is level.
  - \* Check that the correct temperatures and shelf positions are being used.
- ***The oven light is not working***
  - \* Refer to the “Replacing the oven bulb” section.
- ***I am getting condensation in my oven***
  - \* Steam and condensation is a natural by product of cooking any food with high water content, such as frozen food, chicken etc.
  - \* You may get condensation in the oven cavity and forming between the oven door glasses. This is not necessarily a sign that the oven is not working correctly.
  - \* Do not leave food in the oven to cool after it has been cooked and the oven has been switched off.
  - \* Use a covered container, where practical, when cooking to reduce the amount of condensation that forms.



***IMPORTANT: If your appliance appears not to be operating correctly, then you should disconnect it from your mains supply and then contact the Baumatic Service Department on telephone number (0118) 933 6911.***

***DO NOT ATTEMPT TO REPAIR THE APPLIANCE YOURSELF.***

Please note that if an engineer is asked to attend whilst the product is under guarantee and finds that the problem is not the result of an appliance fault, then you may be liable for the cost of the call out charge.

***The appliance must be accessible for the engineer to perform any necessary repair. If your appliance is installed in such a way that an engineer is concerned that damage will be caused to the appliance or your kitchen, then he will not complete a repair.***

***This includes situations where appliances have been tiled in, sealed in with sealant, have wooden obstructions placed in front of the appliance, like plinths. Or any installation other than the one specified by Baumatic Ltd. has been completed.***

Please refer to the conditions of guarantee that appear on the warranty card that you receive with the appliance.

***IMPORTANT: Baumatic Ltd. operates a policy of continuous improvement and reserves the right to adjust and modify its products without prior notification.***





***United Kingdom***

Baumatic Ltd.,  
Baumatic Buildings,  
6 Bennet Road,  
Reading, Berkshire  
RG2 0QX  
United Kingdom

**Sales Telephone**

(0118) 933 6900

**Sales Fax**

(0118) 931 0035

**Customer Care Telephone**

(0118) 933 6911

**Customer Care Fax**

(0118) 986 9124

**Spares Telephone**

(01235) 437244

**Advice Line Telephone**

(0118) 933 6933

**E-mail:**

sales@baumatic.co.uk  
customercare@baumatic.co.uk  
spares@baumatic.co.uk  
technical@baumatic.co.uk

**Website:**

www.baumatic.co.uk

***Republic of Ireland***

**Service Telephone**

1-890 812 724

**Spares Telephone**

091 756 771

***Czech Republic***

Baumatic CR spol s.r.o.  
Lípová 665  
460 01 Liberec 4  
Czech Republic

+420 483 577 200

www.baumatic.cz

***Slovakia***

Baumatic Slovakia, s.r.o.  
Galvániho 7/D  
Slovakia

+421 255 640 618

***Germany***

Baumatic GmbH  
Lillienthalstrasse 1  
320 52 Herford  
Deutschland

+49 5221 694 99-0

www.baumatic.de

***Italy***

Baumatic Italia S.R.L.  
Via Galvani N.3  
35011 Campodarsego (PD)

+3904 9920 2297

www.baumatic.it

***Holland***

Baumatic Benelux B.V.  
Grindzuigerstraat 22  
1333 MS ALMERE  
Nederland

+3136 549 1555

www.baumatic.nl





