



Portable Sprinkler Pump

Item 68421

⚠ WARNING

Read this material before using this product.
Failure to do so can result in serious injury.
SAVE THIS MANUAL.



When unpacking, make sure that the product is intact and undamaged.
If any parts are missing or broken, please call 1-800-444-3353 as soon as possible.

Visit our website at: <http://www.harborfreight.com>

Save This Manual

Keep this manual for the safety warnings and precautions, assembly, operating, inspection, maintenance and cleaning procedures. Write the product's serial number in the back of the manual near the assembly diagram (or month and year of purchase if product has no number). Keep this manual and the receipt in a safe and dry place for future reference.

⚠WARNING

When using electric pumps, basic safety precautions should always be followed to reduce the risk of fire, electric shock, and personal injury. **READ ALL INSTRUCTIONS BEFORE USING THIS PUMP!**

1. This Pump has not been investigated for use in swimming pool or marine areas.
2. Use only with clear water. Do not use with flammable liquids such as gasoline, chemicals or and corrosive liquids.
3. Risk of electric shock – This pump is supplied with a grounding conductor and grounding-type attachment plug. To reduce the risk of electric shock, connect only to a properly grounded, grounding-type receptacle.
4. If there is danger of flooding, the electrical connections must be taken to higher ground.
5. DO NOT IMMERSE IN WATER. This is not a submersible pump. Use indoors only.
6. Always lock up pumps and keep out of reach of children.
7. Wear ANSI-approved safety goggles during installation.
8. DISCONNECT POWER. Unplug when not in use, before servicing, and when changing accessories.
9. CHECK DAMAGED PARTS. Before using any pump, check for alignment and binding of moving parts; any broken parts or mounting fixtures; and any other condition that may affect proper operation. Any part that is damaged should be properly repaired or replaced by a qualified technician.
10. REPLACEMENT PARTS AND ACCESSORIES. When servicing, use only identical replacement parts. Use of any other parts will void the warranty. Only use accessories intended for use with this pump. Approved accessories are available from Harbor Freight Tools.
11. The pump must be protected from frost.
12. The pump must be protected from running dry.
13. Do not run the pump with the outlet closed or blocked. The connections may burst due to excessive pressure.
14. WARNING: Handling the cord on this product will expose you to lead, a chemical known to the State of California to cause cancer, and birth defects or other reproductive harm. Wash hands after handling. (California Health & Safety Code § 25249.5, et seq.)

Grounding Instructions

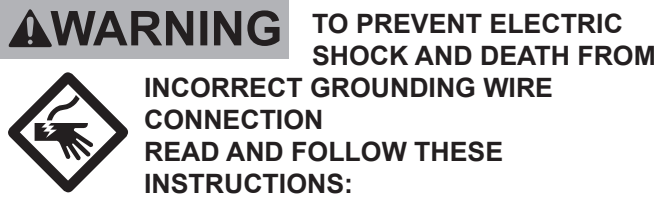

Check with a qualified electrician if you are in doubt as to whether the outlet is properly grounded. Do not modify the power cord plug provided with the tool. Never remove the grounding prong from the plug. Do not use the tool if the power cord or plug is damaged. If damaged, have it repaired by a service facility before use. If the plug will not fit the outlet, have a proper outlet installed by a qualified electrician.

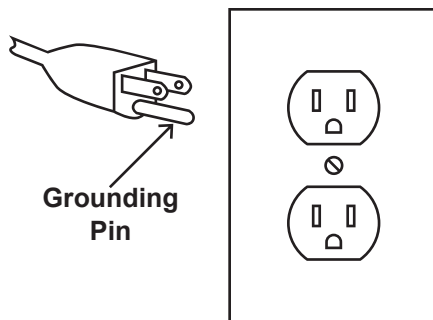

125 V~ 3-Prong Plug and Outlet
(for up to 125 V~ and up to 15 A)

- Tools marked with "Grounding Required" have a three wire cord and three prong grounding plug. The plug must be connected to a properly grounded outlet. If the tool should electrically malfunction or break down, grounding provides a low resistance path to carry electricity away from the user, reducing the risk of electric shock. **(See 3-Prong Plug and Outlet.)**
- The grounding prong in the plug is connected through the green wire inside the cord to the grounding system in the tool. The green wire in the cord must be the only wire connected to the tool's grounding system and must never be attached to an electrically "live" terminal. **(See 3-Prong Plug and Outlet.)**
- The tool must be plugged into an appropriate outlet, properly installed and grounded in accordance with all codes and ordinances. The plug and outlet should look like those in the preceding illustration. **(See 3-Prong Plug and Outlet.)**
- This pump is intended for use on a circuit that has an outlet that looks like the one illustrated above in **125 V~ 3-Prong Plug and Outlet**. The pump has a grounding plug that looks like the plug illustrated above in **125 V~ 3-Prong Plug and Outlet**.
- The outlet must be properly installed and grounded in accordance with all codes and ordinances.

- Do not use an adapter to connect this pump to a different outlet.

Extension Cords











- Grounded** tools require a three wire extension cord. **Double Insulated** tools can use either a two or three wire extension cord.
- As the distance from the supply outlet increases, you must use a heavier gauge extension cord. Using extension cords with inadequately sized wire causes a serious drop in voltage, resulting in loss of power and possible tool damage. **(See Table A.)**
- The smaller the gauge number of the wire, the greater the capacity of the cord. For example, a 14 gauge cord can carry a higher current than a 16 gauge cord. **(See Table A.)**
- When using more than one extension cord to make up the total length, make sure each cord contains at least the minimum wire size required. **(See Table A.)**
- If you are using one extension cord for more than one tool, add the nameplate amperes and use the sum to determine the required minimum cord size. **(See Table A.)**
- If you are using an extension cord outdoors, make sure it is marked with the suffix "W-A" ("W" in Canada) to indicate it is acceptable for outdoor use.
- Make sure the extension cord is properly wired and in good electrical condition. Always replace a damaged extension cord or have it repaired by a qualified electrician before using it.
- Protect the extension cords from sharp objects, excessive heat, and damp or wet areas.

TABLE A: RECOMMENDED MINIMUM WIRE GAUGE FOR EXTENSION CORDS*
(120/240 VOLT)

NAMEPLATE AMPERES (at full load)	EXTENSION CORD LENGTH				
	25'	50'	75'	100'	150'
0 – 2.0	18	18	18	18	16
2.1 – 3.4	18	18	18	16	14
3.5 – 5.0	18	18	16	14	12
5.1 – 7.0	18	16	14	12	12
7.1 – 12.0	18	14	12	10	-
12.1 – 16.0	14	12	10	-	-
16.1 – 20.0	12	10	-	-	-

* Based on limiting the line voltage drop to five volts at 150% of the rated amperes.

Symbology

	Double Insulated
	Canadian Standards Association
	Underwriters Laboratories, Inc.
	Volts Alternating Current
	Amperes
n_0 xxxx/min.	No Load Revolutions per Minute (RPM)
	WARNING marking concerning Risk of Eye Injury. Wear ANSI-approved safety goggles with side shields.
	Read the manual before set-up and/or use.
	WARNING marking concerning Risk of Hearing Loss. Wear hearing protection.
	WARNING marking concerning Risk of Fire. Do not cover ventilation ducts. Keep flammable objects away.
	WARNING marking concerning Risk of Electric Shock. Properly connect power cord to appropriate outlet.

Specifications

Power Requirements	120 V~ / 60 Hz / 11.1 A
Maximum Flow	1150 GPH
Maximum Lift	154 FT.
Pressure	67 PSI
Motor	1-1/5 Horsepower Electric
Inlet and Outlet Diameter	1 IN. NPT
Cord Length	5 FT. 2 IN.



Unpacking

When unpacking, make sure that the item is intact and undamaged. If any parts are missing or broken, please call Harbor Freight Tools at 1-800-444-3353 as soon as possible.

Set up

WARNING! This is NOT a submersible pump. Do not immerse in water.

Pipe Connection

The Pump uses 1" NPT piping (sold separately). Purchase the necessary length of pipe, including any needed fittings and bends. Mount the Pump as close to the source of water as possible and within the range of the rated Suction Lift. The connections must be airtight. Wrap all threaded connections with PTFE tape (sold separately).

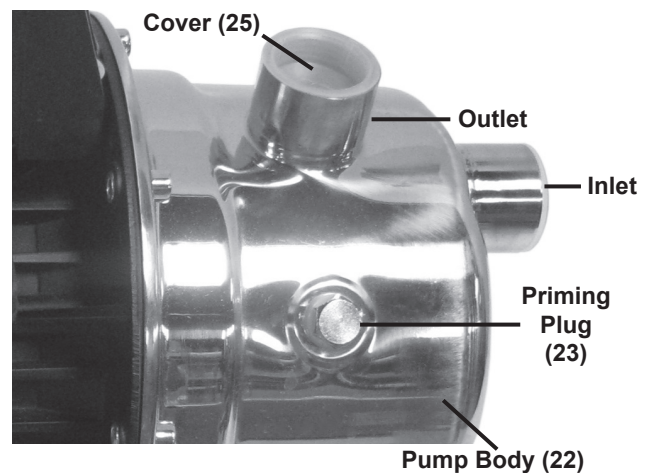

1. Remove the Inlet and Outlet covers (25) from the Pump.
2. Attach the water source to the Inlet, using appropriate methods. The Inlet hose or pipe must be collapse-proof to properly withstand the suction force.
3. Install a foot valve and filter (sold separately) at the bottom of the inlet.
4. Attach the outlet connection to the Outlet. A Y-fitting with dual valves (sold separately) is helpful for priming the pump (see next section).

Operation

WARNING TO PREVENT ELECTRIC SHOCK AND DEATH:



Make sure that the Connection Box Cover (42) is properly closed and sealed before priming or operation.

Note: A foot valve on the inlet connection is critical to help prevent the pump from losing prime.

Note: Check that the water source and piping are clear of sand, dirt and debris.

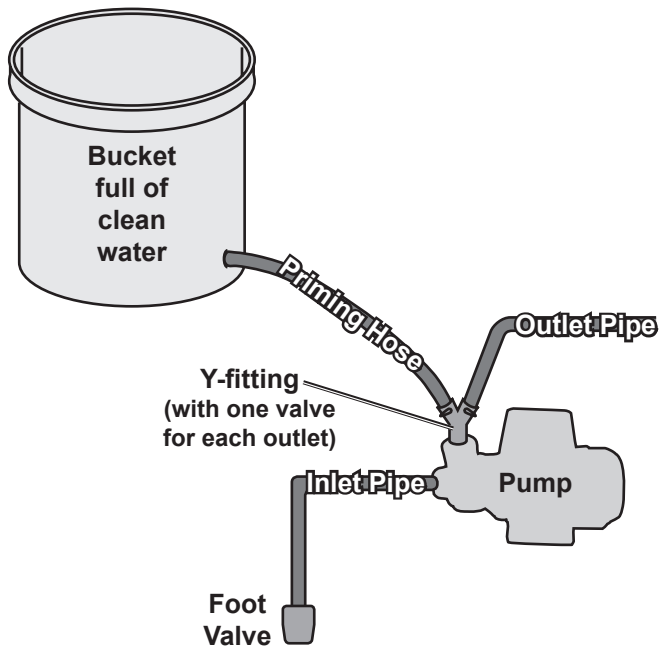

1. Connect a bucket full of at least 3 gallons of water to one side of the Y-fitting using a hose, as shown above. (If available, a continuous water supply, such as a spigot, may be used instead.) The bucket must be positioned higher than the pump's outlet.
2. Close the valve on the outlet side of the Y-fitting, and open the valve on the priming side of the Y-fitting.
3. Remove the Priming Plug (23) and wait until water starts coming out of the Priming Plug. Replace the Priming Plug and tighten securely.
4. To start the pump:
 - a. Open the valve on outlet side of the Y-fitting.
 - b. Make sure your hands are dry.
 - c. Plug in the pump.
 - d. Close the valve on the priming side of the Y-fitting.

CAUTION: Do not run the Pump Dry! Turn off the Pump IMMEDIATELY if water stops coming out the Outlet.

5. If you operate the Pump and no water comes out, shut the Pump off IMMEDIATELY. Check the pipes for air-tightness. Check also that the bottom of the Inlet pipe is underneath the surface of the water and a foot valve is properly installed.
6. After the pump is running properly, the priming hose and bucket can be disconnected.

Storage

1. If you will not be using the Pump for an extended period of time, drain the Pump Body (22). First disconnect both the suction and outlet lines, then tip the pump so that all the water is drained from the pump cavity.
2. If the Pump sits idle for a period of 5 days or more, it should be unplugged and rotated with a screwdriver through the middle hole of the fan cover through several revolutions to prevent it from taking a permanent set.
3. If you use the Pump only occasionally, when you are done pumping, replace the Inlet and Outlet covers to protect the unit.

Troubleshooting

Problem	Possible Causes	Likely Solutions
Motor will not start.	<ol style="list-style-type: none"> 1. Cord not connected. 2. No power at outlet. 3. Fuse is blown or breaker tripped. 4. Internal damage or wear. (Carbon brushes or switch, for example.) 	<ol style="list-style-type: none"> 1. Check that cord is plugged in. 2. Check power at outlet. If outlet is unpowered, turn off tool and check circuit breaker. If breaker is tripped, make sure circuit is right capacity for tool and circuit has no other loads. 3. Have fuse replaced by a qualified service technician. 4. Have serviced by a qualified service technician.
Motor runs but water isn't pumping.	<ol style="list-style-type: none"> 1. Improper priming. 2. Clogged filter at end of intake connections. 3. Discharge valve closed. 4. Pipe size too small. 5. Impeller plugged. 6. Pipes frozen. 	<ol style="list-style-type: none"> 1. Re-prime according to directions. 2. Clean filter. 3. Open discharge valve. 4. Re-pipe using pipe of the same size as the Pump inlet and outlet ports. 5. Have Impeller cleaned by qualified service technician. 6. Thaw pipes. Check for damage before using pump.
Pump does not deliver water at full capacity.	<ol style="list-style-type: none"> 1. Corroded pipes. 2. Piping size too small. 3. Not enough water supplied to Pump. 4. Low Voltage. 	<ol style="list-style-type: none"> 1. Replace pipes. 2. Re-pipe using pipe of the same size as the Pump inlet and outlet ports. 3. Enlarge inlet pipe. Check well pump system. 4. Check that outlet is 120V.
Excessive noise or rattling.	Internal damage or wear. (Carbon brushes or bearings, for example.)	Have technician service tool.



Follow all safety precautions whenever diagnosing or servicing the tool. Disconnect power supply before service.

Wiring Diagram

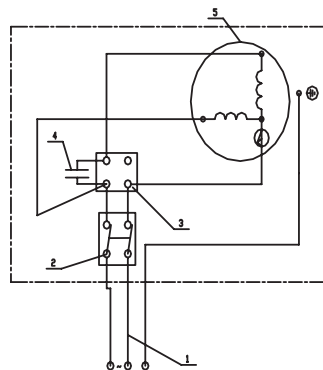

1	POWER CABLE
2	PRESSURE SWITCH
3	TERMINAL
4	CAPACITOR
5	MOTOR

Parts List and Diagram

Item	Description	Qty	Item	Description	Qty	Item	Description	Qty
1	Fan Cover	1	20	Diffuser Assembly	1	39	Nut	1
2	Fan	1	21	O-Ring	1	40	Capacitor	1
3	Bolt	4	22	Pump Body	1	41	Seal	1
4	Rear Cover	1	23	Priming Plug	2	42	Connection Box Cover	1
5	Spring Plate	1	24	Seal Ring	2	43	Switch	1
6	Rotor	1	25	Cover (Inlet and Outlet)	2	44	Cover Frame	1
7	Bearing	2	26	Screw	8	45	Switch Cover	1
8	Stator	1	27	Gasket	1	46	Screw	2
9	Power Cable	1	28	Connection Box	1	47	O-Ring	2
10	Nut	9	29	Screw	4	48	Handle Cover	1
11	Front Cover	1	30	Cable Clamp	1	49	Handle	1
12	Washer	1	31	Screw	2	50	Bolt	1
13	Fluid Housing	1	32	Connection Board	1	51	Flat Washer	1
14	301-12 Mechanical Seal	1	33	Nut	3	52	Foot	1
15	O-Ring	1	34	Screw	6	53	Screw	1
16	Impeller Assembly	1	35	Spring Washer	9	54	Shim	1
17	O-Ring	1	36	Flat Washer	13			
18	Front Fluid Housing	1	37	Lock Ring	1			
19	O-Ring	1	38	Grommet	1			

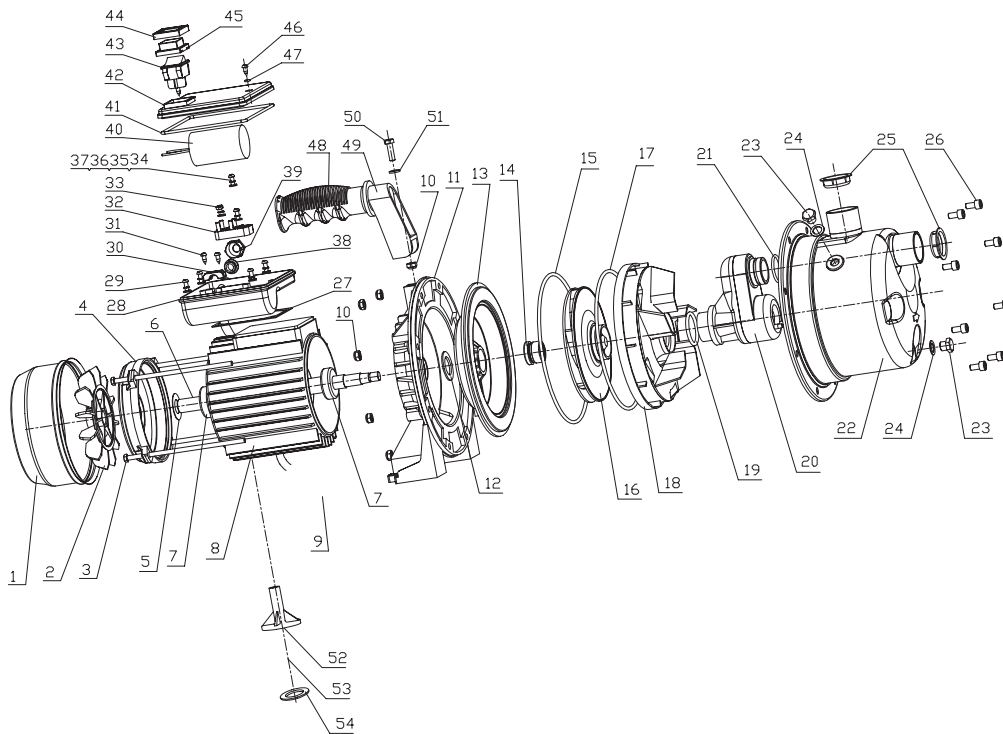

Record Product's Serial Number Here: _____

Note: If product has no serial number, record month and year of purchase instead.

Note: Some parts are listed and shown for illustration purposes only, and are not available individually as replacement parts.

PLEASE READ THE FOLLOWING CAREFULLY

THE MANUFACTURER AND/OR DISTRIBUTOR HAS PROVIDED THE PARTS DIAGRAM IN THIS MANUAL AS A REFERENCE TOOL ONLY. NEITHER THE MANUFACTURER NOR DISTRIBUTOR MAKES ANY REPRESENTATION OR WARRANTY OF ANY KIND TO THE BUYER THAT HE OR SHE IS QUALIFIED TO MAKE ANY REPAIRS TO THE PRODUCT OR THAT HE OR SHE IS QUALIFIED TO REPLACE ANY PARTS OF THE PRODUCT. IN FACT, THE MANUFACTURER AND/OR DISTRIBUTOR EXPRESSLY STATES THAT ALL REPAIRS AND PARTS REPLACEMENTS SHOULD BE UNDERTAKEN BY CERTIFIED AND LICENSED TECHNICIANS AND NOT BY THE BUYER. THE BUYER ASSUMES ALL RISK AND LIABILITY ARISING OUT OF HIS OR HER REPAIRS TO THE ORIGINAL PRODUCT OR REPLACEMENT PARTS THERETO, OR ARISING OUT OF HIS OR HER INSTALLATION OF REPLACEMENT PARTS THERETO.

Limited 90 Day Warranty

Harbor Freight Tools Co. makes every effort to assure that its products meet high quality and durability standards, and warrants to the original purchaser that this product is free from defects in materials and workmanship for the period of 90 days from the date of purchase. This warranty does not apply to damage due directly or indirectly, to misuse, abuse, negligence or accidents, repairs or alterations outside our facilities, criminal activity, improper installation, normal wear and tear, or to lack of maintenance. We shall in no event be liable for death, injuries to persons or property, or for incidental, contingent, special or consequential damages arising from the use of our product. Some states do not allow the exclusion or limitation of incidental or consequential damages, so the above limitation of exclusion may not apply to you. THIS WARRANTY IS EXPRESSLY IN LIEU OF ALL OTHER WARRANTIES, EXPRESS OR IMPLIED, INCLUDING THE WARRANTIES OF MERCHANTABILITY AND FITNESS.

To take advantage of this warranty, the product or part must be returned to us with transportation charges prepaid. Proof of purchase date and an explanation of the complaint must accompany the merchandise. If our inspection verifies the defect, we will either repair or replace the product at our election or we may elect to refund the purchase price if we cannot readily and quickly provide you with a replacement. We will return repaired products at our expense, but if we determine there is no defect, or that the defect resulted from causes not within the scope of our warranty, then you must bear the cost of returning the product.

This warranty gives you specific legal rights and you may also have other rights which vary from state to state.

3491 Mission Oaks Blvd. • PO Box 6009 • Camarillo, CA 93011 • (800) 444-3353



3491 Mission Oaks Blvd. • PO Box 6009 • Camarillo, CA 93011 • (800) 444-3353