

www.opti-ups.com

Placement

This UPS is intended for indoor use only; its internal components are not sealed from the environment. Please install it in a protected environment away from excessive heat or excessive moisture.



Charging the UPS first

The battery is fully charged at the factory. However, it is recommended to charge the battery at least 8 (eight) hours before using the UPS, since energy loss may have occurred during shipping or long duration storage. To recharge the battery, simply leave the UPS plugged into an AC outlet.

Connecting your equipment to the UPS

For all UPS models except the version with IEC outlets: connect the power cord(s) of your computer equipment to the output receptacle(s) of the UPS.

For UPS with IEC outlets, as shown in the illustration, use your computer power cord to connect UPS to the wall socket. Use the power cord supplied with the UPS to connect your PC to one of UPS outlets.

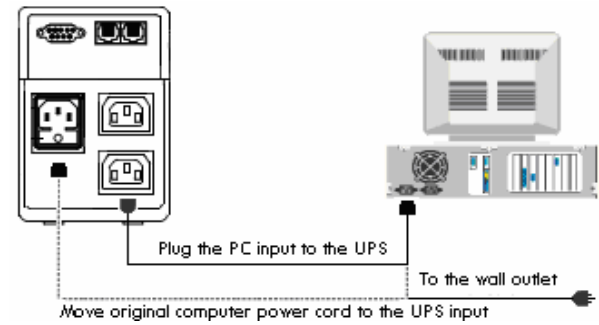

Turn on the UPS

To turn UPS on please press the power button for 3 seconds. Pressing the power button shortly under normal mode will enable the self-test function. The silence function can be enabled/disabled by shortly pressing the power button in backup mode. In addition, the power button can be used as the master on/off switch for your equipment by leaving your equipment connected to UPS and switched on. To turn off the UPS, please press power button for about 3 seconds.

Front & Rear Panels

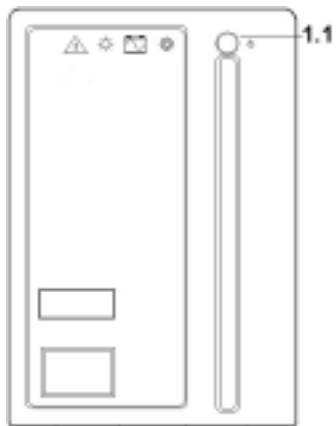

- 1.1 Power Button
- 1.2 RS-232 Port^{*)}
- 1.3 Phone/LAN Jack^{*)}
- 1.4 AC Input
- 1.5 UPS Outlets
- 1.6 AC Fuse

^{*)} TS-B models only

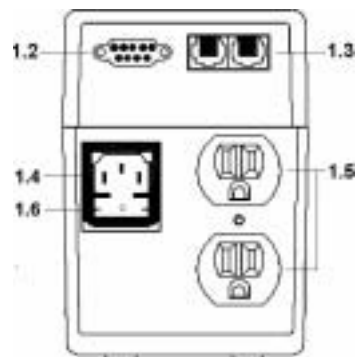
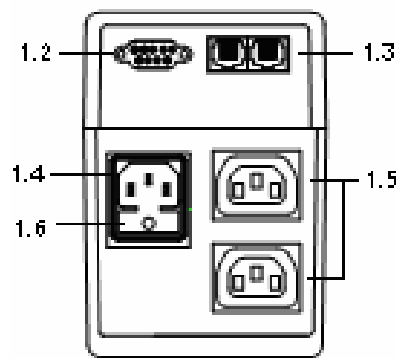

No Load Shutdown Function

As a battery saving feature, the UPS will automatically turn off if none of the connected equipment is operating while the UPS is in back-up mode. Once normal utility power returns, the unit will re-start automatically. You can disable the "No Load Shutdown" function by pressing the power button of your switched-off UPS until you hear two beeps.

Front panel LED (UPS status indicator)

 AC Mode	When the LED is continuously lit and the buzzer is silent, the UPS is in normal mode and providing power to your equipment. The UPS will continue to filter electrical noise and provide surge protection.
 Battery Mode	When the LED blinks every 2 seconds in time with the beeping sound, the UPS is providing power from its battery.
 Fault	When the LED is flashing rapidly and the beeping sound is continuous, it indicates that the UPS is overloaded.

Warning

DO NOT PLUG LASER PRINTERS INTO THE UPS BECAUSE THEY TYPICALLY DRAW TOO MUCH POWER

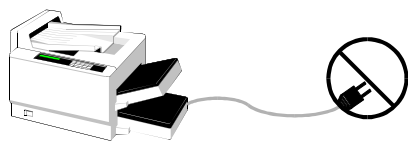

Fuse replacement procedure

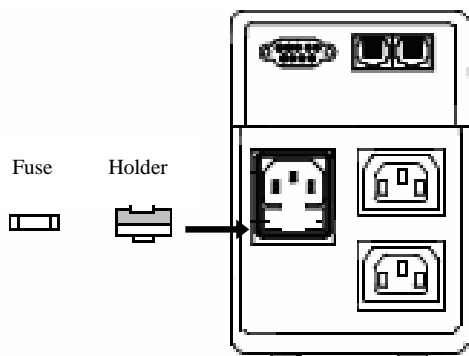

1. Use a slotted screwdriver to take out the fuse holder
2. Take out the busted fuse from the fuse holder
3. Use the screwdriver to push out the spare fuse from the holder
4. Put the spare fuse in the holder
5. Push the fuse holder back into the AC input socket
6. Follow the UPS turn on procedure

Battery replacement procedure

Note: Follow this procedure for safe replacement of the battery. However, small sparks may occur during the process. This is normal.

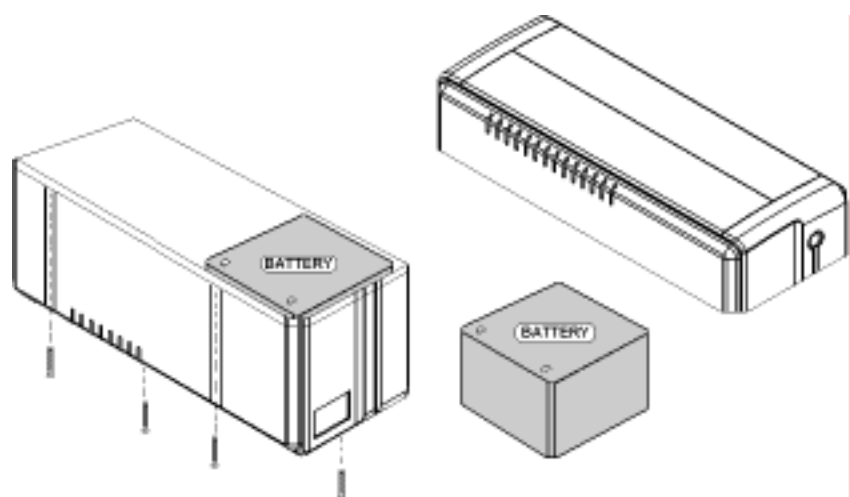

1. Turn off the UPS
2. Remove all plugs
3. Remove the four screws from the side slots
4. Gently remove the top cover
5. Disconnect the two wires connecting the battery to the UPS and pull out the battery
6. Push the new battery into place
7. Connect the wires to the new battery, making sure that the red wire is connected to the red battery terminal and the black wire to the black battery terminal
8. Mount the cover and replace the screws
9. Follow the UPS turn on procedure

Specifications

Model	Thunder Shield 400	Thunder Shield 500(B)	Thunder Shield 650(B)	Thunder Shield 1000(B)
Maximum Capacity	240W	300W	360W	480W
Topology	Line-interactive			
On-battery Output Waveform	Simulated Sine Wave			
Input Voltage Range	110/120V or 220/230/240V +/- 25%			
Input Frequency	50Hz/60Hz Auto Sensing			
Output Voltage Regulation	Rated voltage +/- 5%			
Communication Port	RS232 ^{*)}			
Data Line Surge Protection	RJ11/RJ45 ^{*)}			
Surge Energy Rating	480 Joules			
Recharge Time to 90%	6 hours			
Operating Temperature	0~40°C / 32~104			
Storage Temperature	-20~60°C / -4~140			
Relative Humidity	0 to 95% maximum, non-condensing			
Audible Noise	<40 dBA			
Unit Dimensions (L×W×H), mm	260×97×135		320×97×135	
Net Weight, kg	4.2	6.0 (6.3)	6.2 (6.5)	6.3 (6.7)
EMC/RFI Compatibility	CE			
Safety Certifications	CE, UL, cUL			

^{*)} TS-B models only

Warranty

LIMITED WARRANTY

What the warranty covers:

We guarantee this product to be free from defects in material and workmanship during the warranty period. If a product proves to be defective in material or workmanship during the warranty period, we will at our sole option, repair or replace the product with a like product.

How long the warranty is effective:

For accurate warranty period and conditions, please contact the local branch offices or your dealers.

Who the warranty protects:

This warranty is valid only for the first consumer purchaser.

What the warranty does not cover:

- Any product on which the serial number has been defaced, modified or removed.
- Damage, deterioration or malfunction resulting from:
 - Accident, misuse, neglect, fire, water, or other acts of nature, unauthorized product modification, or failure to follow instructions supplied with the product.
 - Repair or attempted repair by anyone not authorized by OPTI-UPS.
 - The fault is the result of accidental damage or damage in transit or transportation, including but not limited to liquid spillage.
 - Removal or installation of the product.
 - Causes external to the product.
 - Use of supplies or parts not meeting our specifications.
 - Normal wear and tear.
 - Any other cause which does not relate to a product defect.
- Removal, installation and set-up service charges.

Limitation of implied warranties:

There are no warranties, expressed or implied, which extend beyond the description contained herein including the implied warranty of merchantability and fitness for a particular purpose.

Exclusion of damages:

Our liability is limited to the cost of repair or replacement of the product. We shall not be liable for:

- Damage to other property caused by any defects in the product, damages based upon inconvenience, loss of use of the product, loss of time, loss of profits, loss of business opportunity, loss of goodwill, loss of data, loss of software, costs of substitute equipment, interference with business relationships, claims by third parties, or other commercial loss, even if advised of the possibility of such damages.
- Any other damages, whether incidental, consequential or otherwise.
- Any claim against the customer by any other party.

Troubleshooting

Problems	Possible Cause	Solution
UPS can't turn on, LED does not light	Power switch not pressed long enough	Press the power switch for more than 1 second until the UPS turns on
	Battery voltage is less than 10V	Recharge the battery for 6 hours by leaving the UPS plugged in and the load disconnected from the UPS.
	Load is less than 20W at battery mode	Disable "No Load Shutdown Function"
	PCB failure	Call for service
UPS always at battery mode	Input power cord is loose	Plug in the power cord firmly
	Busted input fuse	Replace the fuse
	Input voltage too high or too low	Check input voltage
	PCB failure	Call for service
Back up time too short	Battery is not fully charged or defective	Recharge the battery for 6 hours. If the problem is still present, replace the battery.
	PCB failure	Call for service
Buzzer continuously beeping	Overload	Remove some loads

Contact Information

USA OPTI-UPS Corp. Tel: 1-909-869-5700 Toll Free: (888)OPTI-UPS info@opti-ups.com http://www.opti-ups.com	Australia OPTI Australia Pty Ltd. Tel: 61-3-9545-5322 Toll Free: AU: 1800-678-428 NZ: 088-OPTI-UPS info@opti-ups.com.au http://www.opti-ups.com.au	Taiwan OPTI International Corp. Tel: 886-2-2246-7272 Toll Free: 0800-029898 info@opti-ups.com.tw http://www.opti-ups.com.tw
---	--	---

Europe
OPTI-UPS Europe
Lindenstrasse 12a
81545 Munchen
Tel : +49 (0) 89-31 609 413
Fax : +49 (0) 89-31 609 289

United Kingdom
OPTI UK
DDI 01489 581386
Office 01489 583708