

COMMERCIAL RO SYSTEM 300GPD OPERATION MANUAL



COMMERCIAL RO SYSTEM 300GPD OPERATION MANUAL



Reverse Osmosis Flow Chart

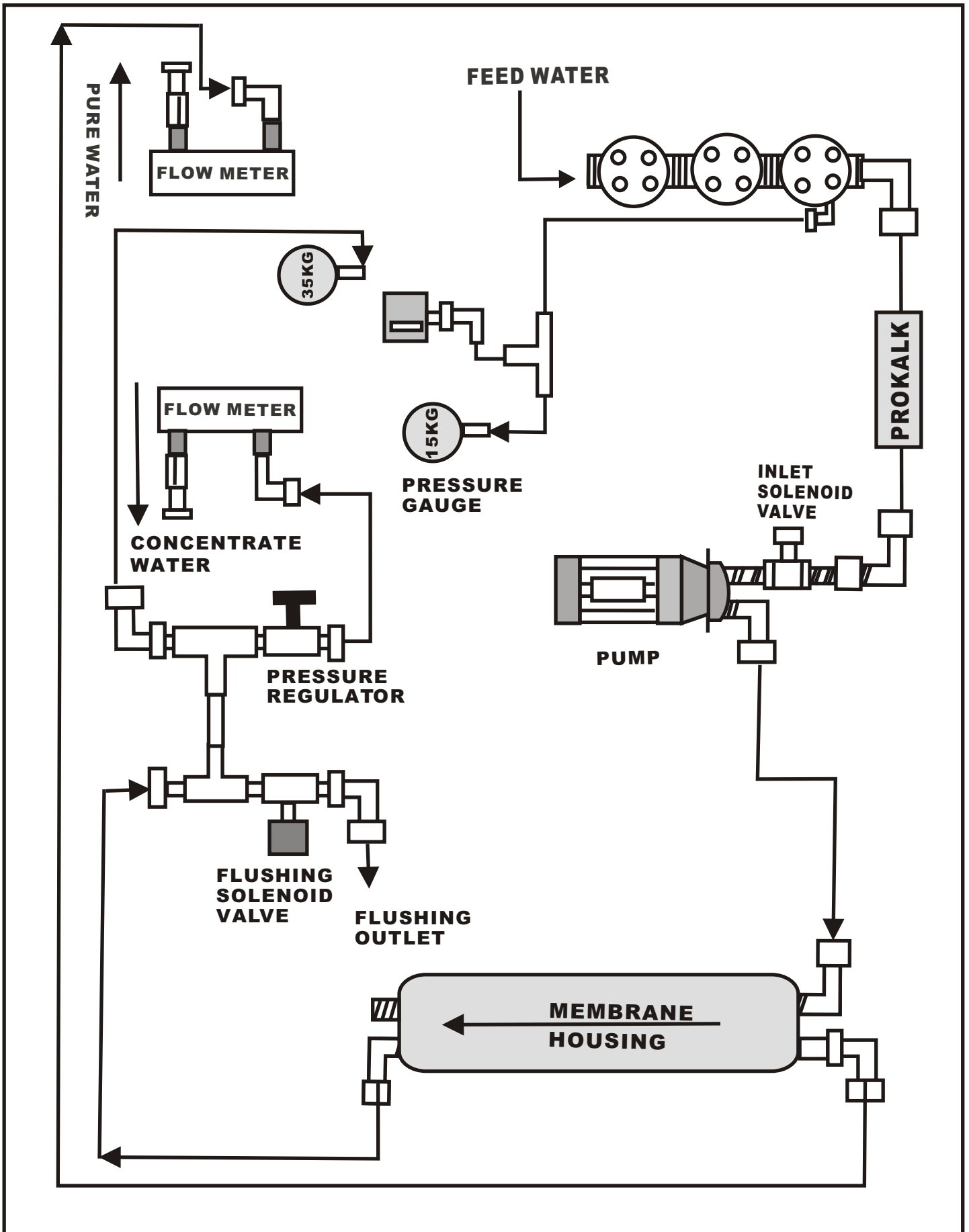

Reverse Osmosis Flow Chart

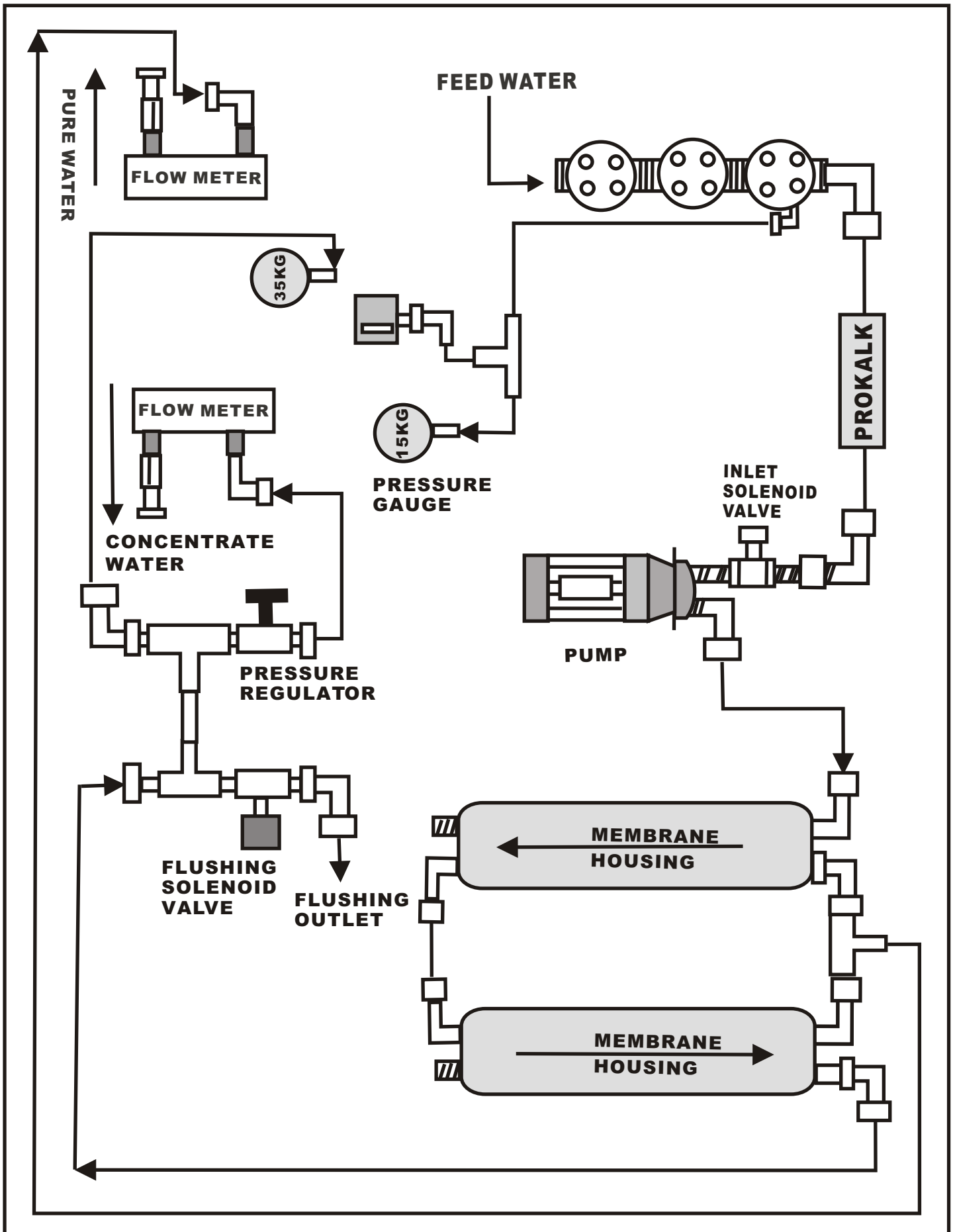

Reverse Osmosis Electrical Diagram

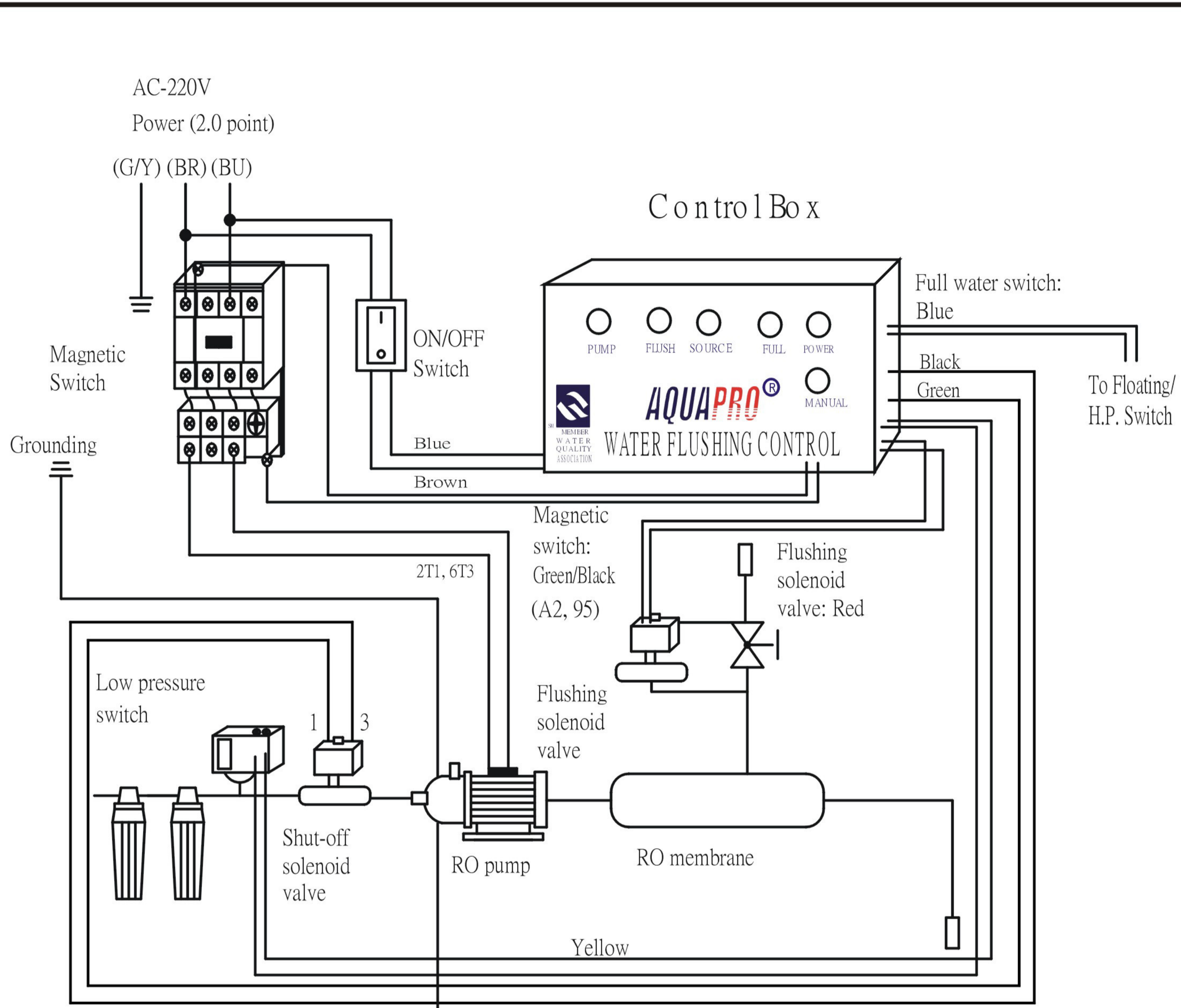

VOLTAGE CONNECTIONS	
Lead	High volt
brown	4
white	5
red	5
black	A

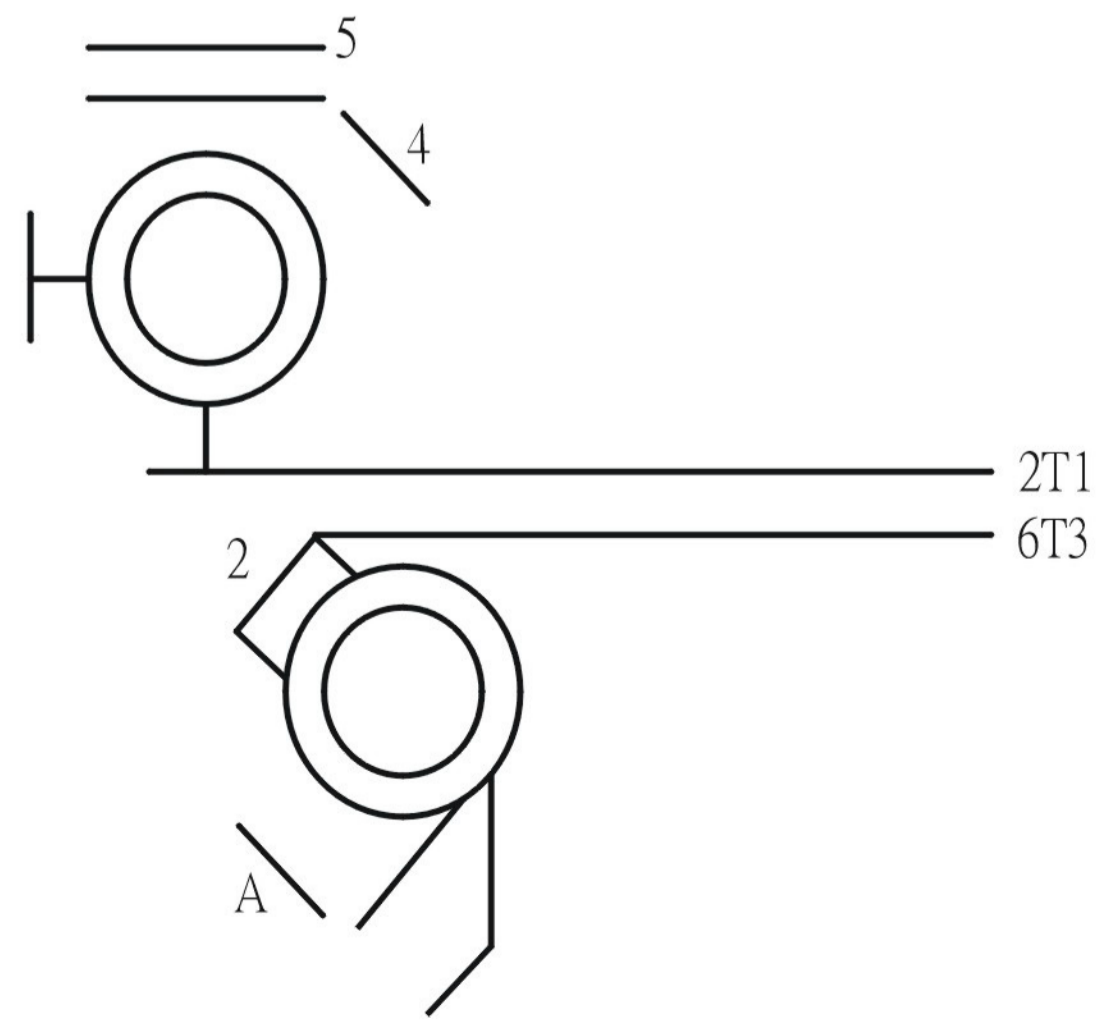

Reverse Osmosis Specification

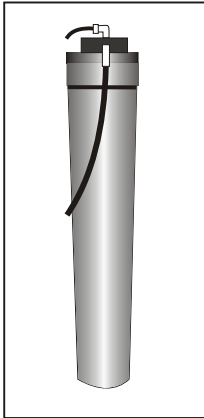

Filter Housing with Cartridges

20" Filter Housing
20" Cartridge: Sediment 5, 1micron
Carbon Block
Carbon Block

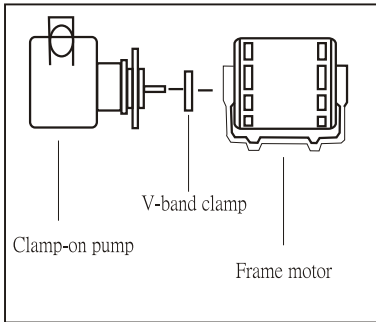

Booster Pump & Motor

1. Pump : PROCON 1504
2. Flow Rate : 125GPH
3. Motor : 1/2 HP
4. Voltage: 110/8.6A/220V/
4.3A/60Hz/50Hz
5. R.P.M. : 1725

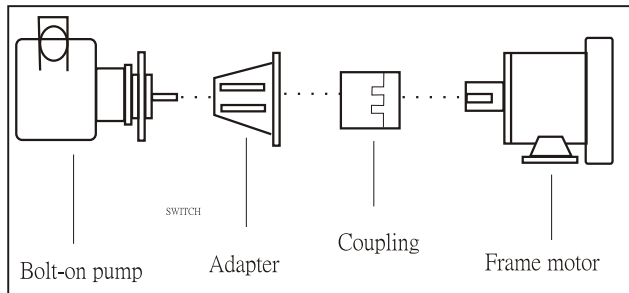

Booster Pump & Motor

1. Pump : PROCON 2507
2. Flow Rate : 240GPH
3. Motor : 1 HP
4. Voltage: 110V/14A/ 220V/7A/60Hz/50Hz
5. R.P.M. : 1725

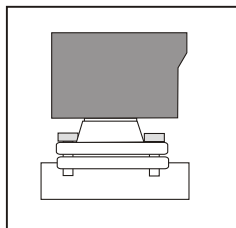

Solenoid Valve

Shutting down while Low pressure switch sends out signal.
Flushing while control box sends out flushing signal.

	Inlet	Flush
500-600GPD:	1/2"	3/8"
800-1000GPD:	1/2"	3/8"
1500-2000GPD:	1/2"	1/2"

Reverse Osmosis Specification

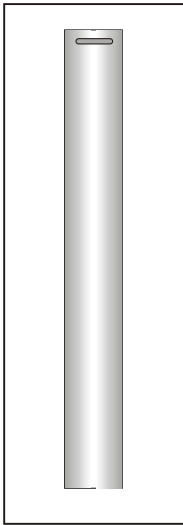

RO Membrane & RO Housing

(A) RO Membrane Housing

(B) RO Membrane:

1. Specification of Membrane

- (1) Max. Operation Pressure: 300PSI~600PSI
- (2) Max. Operation Temperature: 45°C
- (3) Turbidity (NTU): <1
- (4) Chlorine: 0.1PPM
- (5) PH Range: 2~11
- (6) Flow Rate: 10GPM
- (7) Max. S.D.I. Index: 5
- (8) Salt Rejection Rate: 96%

2. Application Data For System Design:

- (1) Max. Operation Pressure: 190~220PSI
- (2) Max. Operation Temperature: 45°C
- (3) Turbidity (N.T.U.): <1
- (4) Chlorine: <0.1PPM
- (5) PH Range: 4~11
- (6) System Inlet Water pressure: 3.5KG+/- 15%
- (7) Max. S.D.I. Index: 4
- (8) Salt Rejection Rate: 96%
- (9) Product Water Generate: 25%

(C) Testing Environment: 25°C/pH=8

- (1) NaCl: 2000 PPM
- (2) Operating Pressure: 225PSI
- (3) Recovery Rate: 15%

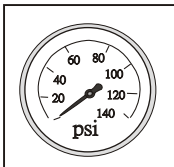

Water Inlet pressure Gauge

0~15 KG/CM² Oil-Filled Pressure Gauge

Not allow to operate under 1.5KG/CM²

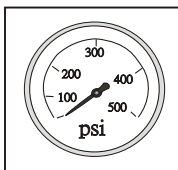

RO Inlet Water Pressure Gauge

0~35KG/CM² (30bar)Oil-Filled Pressure Gauge, set the pressure between 150~180PSI to get the maximum performance.

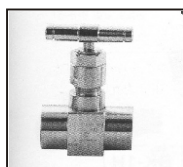

Pressure Regulator

Adjust Clockwise to boost RO operating pressure, Counterclockwise to Lower operating pressure.

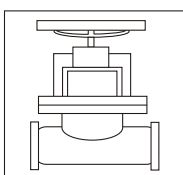

Gate Valve

Only for vertical pump using.

Reverse Osmosis Specification

Flow Meter

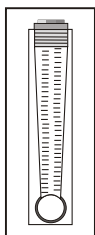

0.2~2GPM

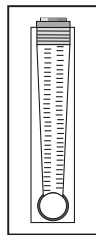

0.5~5GPM

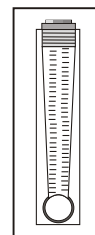

1.0~10GPM

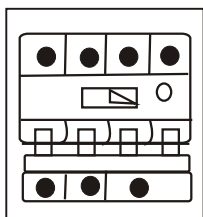

Electromagnetic Switch

1HP	FOR	1/2	HORSE POWER MOTOR (Single Phase)
3HP	FOR	1	HORSE POWER MOTOR (Single Phase)
5HP	FOR	3	HORSE POWER MOTOR (Single Phase)
7.5HP	FOR	4 OR 5	HORSE POWER MOTOR (Three Phase)

Microprocessor Controller

Model: MC-2---Six lights microprocessorized automatic flush controller.

Power: 230VAC, 50/60Hz, or 24VDC

Function: Controller processing steps:

- (1) Automatically flush for 1 minute and 30 seconds when the machine starts its first time.
- (2) Water-generating detection: Automatically flush for 1 minute and 30 seconds after the accumulated time reaches 12 hours.
- (3) Input water detection: It will not start control system (stop pump/solenoid valve) if the low pressure switch delays for 5 seconds (out of source water).
- (4) Output water detection: When production water is full, Full water lamp is on and stop pump/solenoid valve.

Configurations:

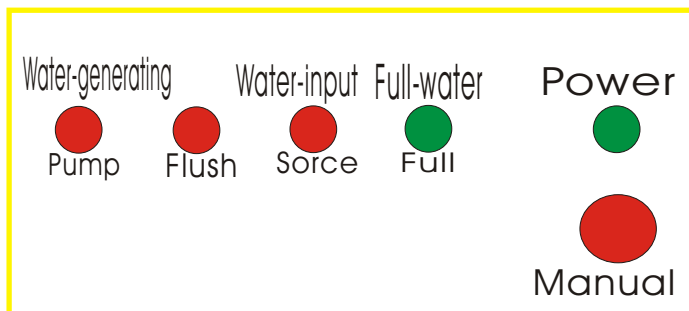

INDICATION OF EACH LAMP:

- PUMP:** Water-generating, will be on when pump is generating.
FLUSH: Auto flush function, will be on when it is flushing automatically.
SOURCE: Water-input, will be on when it is short of water.
FULL: Full-water, will be on when water tank is full.
POWER: Will be always on.
MANUAL: Manual flush function, will be on when flushing by manual.

WRING INSTRUCTION:

1. Low Pressure Switch- **YELLOW** with AMP connector
2. Floating/Pressure Switch-**BLUE** with AMP male connector
3. Flushing Valve-**RED** with AMP connector
4. Booster Pump-**GREEN/BLACK** With AMP connector
5. Inlet Valve-**GREEN/BLACK** With AMP connector
6. Power-**BLUE/BROWN** Line with Plug

Reverse Osmosis Installation Reminder

1. Make sure the voltage and phase of the system you order, never use wrong setting.
2. Check the pure/concentration water are piping right.
3. The power line core should large enough (not less than 3.5 mm)
4. Be ware do not let brine flow through the system while water softener is backwashing.
5. Make sure the water softener's In/Out are connected correct.
6. Measure feed water pressure with a water pressure gauge. Feed water pressure is preferably to be 35 psi and the minimum is 26 psi. If lower than 26 psi, it should install a booster pump at the feed water location.
7. Check prefilters every week to make sure the water supply.
8. If the equipment comes with Ultraviolet Device, make sure you have a steady Power supply in protection of the U.V. Lamp.

Replacement of Filter Cartridges

The replacement of filter cartridges depends greatly on the quality and condition of the water in local area where the reverse osmosis system is placed. Please follow the instructions below to ensure good performance of the system.

1. It is most recommended to replace the filter cartridges every three months.
2. After a while's usage, check regularly Reverse Osmosis Panel's Inlet Water Pressure Gauge. If its water pressure is 15% lower than the feed water Pressure, it is recommended to replace the filter cartridges.
E.g. If the feed water pressure is 2bar (35psi), and the Inlet Water Gauge's Index is 1.7bar (29psi), it is recommended to replace the filter cartridges.

Reverse Osmosis Setup Suggestion

1. If possible, install the active carbon filter and water softener to ensure the incoming water quality.
2. Water softener should regenerate the resin by adding salt to its salt tank. Do it regularly.
3. If not install the water softener, lower the pure/concentration water ratio by adjusting the pressure adjust needle valve(RO Needle Valve).
4. Change pure/concentration water ratio, you should always notice the motor operating pressure, adjust it from the PROCON bypass to ensure the motor is running at the best condition.
5. If your water incoming pressure lower than 1 kg/CM^2 , remember to add a pump in front of the system.
6. The lines left on side of autoflushing timer are used for level control or high pressure switch (If you are using a pressurize storage device).
7. Please use Hardness Tester (5B) to know your water hardness. Make sure the water softener is working fine.
8. Please use the Chlorine Tester to detect the active carbon's working condition, change active carbon when necessary.
9. Cleaning R.O. membrane when the product rate declined 10% or pressure drop up 15%, the following figure tell you how:

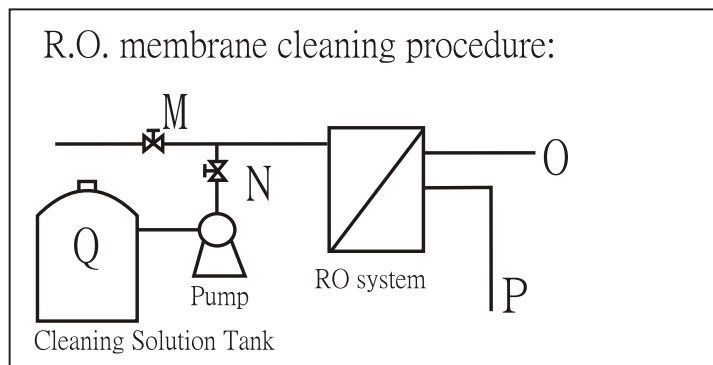

- a. Take pure water pipe (O) out and put it into drain.
- b. Put concentration water pipe (P) into cleaning solution (Q).
- c. Start pump (Notice: Make sure to release the air gather in pipes).
- d. Close (M) valve, open (N) valve, let cleaning solution suck into R.O. system.
- e. Adjust needle valve (Pressure adjusting valve) to the maximum level. And let it run for 30 minutes. After 30 minutes, adjust pressure to 60 psi, run for another 30 minutes.
- f. Put concentration water pipe back to the drain, adjust pressure to maximum level, flush for 1 minute and it's done.

Note: Using the right cleaning solution to clean different types of scale, the cleaning solution PH should range from 3 to 10 at temperature of 35°C .