

User Manual



LIM2010

Line Isolation Monitor



Bender Inc.

USA:

700 Fox Chase

Coatesville, PA 19320

Toll Free: 800-356-4266

Phone: 610-383-9200

Fax: 610-383-7100

E-mail: medical@bender.org

Canada:

5810 Ambler Drive, Unit 1

Mississauga, ON L4W 4J5

Toll Free: 800-243-2438

Phone: 905-602-9990

Fax: 905-602-9960

E-mail: info@bender-ca.com

Web: www.bender.org

NAE2025011, 02.2013

Replaces NAE2025010, 11.2012

© Bender Inc.

All rights reserved.

Content subject to change.

Table of Contents

1. Introduction.....	5
1.1 LIM2010 Line Isolation Monitor	5
1.2 Bus Capability	5
2. Safety Instructions.....	7
3. Installation and Connection	9
3.1 LIM2010 Mounting and Dimensions.....	9
3.2 Wiring	10
3.2.1 BATTERY LOW Error on Initial Startup.....	11
3.2.2 Connector plate CP-LIM2010: Diagram.....	12
3.2.3 Connector Plate CP-LIM2010: Terminal Legend	13
3.2.4 Terminal RI2 For Remote Annunciation	14
3.2.5 Wiring Diagram: LIM2010, No Remote	15
3.2.6 Wiring Diagram: Adding Load Monitoring	16
3.2.7 Wiring Diagram: Adding Ground Fault Location	17
3.2.8 Wiring Diagram: LIM2010 and MK2000	18
3.2.9 Wiring Diagram: LIM2010 and MK2000C.....	19
3.2.10 Wiring Diagram: LIM2010 and MK2000P.....	20
3.2.11 Wiring Diagram: LIM2010 and MK2000CP	21
3.2.12 Wiring Diagram: LIM2010 and MK2000CBM	22
3.3 RS-485 Bus Topology and Termination.....	23
4. Operating and Settings	24
4.1 Front Panel Display - Normal Condition	24
4.2 Front Panel Display - Alarm Condition	26
4.3 Displaying Measured Values	27
4.4 Procedure for Functional Test of LIM2010.....	27
4.5 Factory Settings	28
4.6 LIM2010 Main Menu.....	31
4.6.1 Operating Elements and Displays	31
4.6.2 Navigation Through the Menu.....	31
4.6.3 Menu Structure	33
4.6.4 Main Menu.....	34

4.6.5	Menu: VALUES.....	35
4.6.6	Menu: HISTORY	36
4.6.7	Menu: DATALOG (Logging for up to 300 data points)	37
4.6.8	Menu: SETTING.....	38
4.6.9	Menu: SETTING/GENERAL	39
4.6.10	Menu: SETTING/RELAY	40
4.6.11	Menu: SETTING/BUZZER.....	42
4.6.12	Menu: SETTING/HISTORY	42
4.6.13	Menu: SETTING/DATALOG.....	43
4.6.14	Menu: SETTING/INTERFACE (Bus Address)	43
4.6.15	Menu: SETTING/CLOCK	44
4.6.16	Menu: SETTING/PASSWORD	44
4.6.17	Menu: SETTING/FACTORY SETTING.....	44
4.6.18	Menu: SETTING/SERVICE.....	45
4.6.19	Menu: CONTROL/TEST	45
4.6.20	Menu: CONTROL/COMMUNICATION TEST	45
4.6.21	Menu: INFO.....	46
5.	Periodic Testing.....	47
6.	Messages from the RS-485 Bus.....	48
6.1	Alarm Messages.....	48
6.2	Operating Status Messages.....	49
7.	Technical Data	50
7.1	LIM2010.....	50
7.2	Connector Plate.....	54
7.3	Current Transformers	54
7.3.1	Technical Data: STW3	54
7.3.2	Technical Data: STW4	55
7.3.3	General Data: STW3 / STW4.....	55
7.4	Error Codes and Troubleshooting.....	56
7.5	Dimensions: STW3 / STW4	57
7.6	Ordering Information	58

1. Introduction

1.1 LIM2010 Line Isolation Monitor

The Line Isolation Monitor (LIM) LIM2010 measures the impedance of the connected isolated power system to ground. The LIM then uses this value to calculate the maximum Total Hazard Current (THC), which is displayed on the front of the LIM continuously in milliamperes (mA). Total Hazard Current is the calculated maximum fault current passing through a human body to ground if live conductors of the isolated power system were touched.

In addition to the continuously operating digital display, a colored LED bar graph provides indication of Total Hazard Current in the system. The words "SAFE" and "HAZARD" are displayed prominently on the front of the device, coupled with green and red LEDs.

The device is designed to monitor isolated power systems with voltages of 100 to 240 VAC at 50 Hz or 60 Hz without the use of a separate supply voltage.

1.2 Bus Capability

References to devices with "bus capability" will appear throughout this manual. The LIM2010, as well as some remote indicators, feature a two-way RS-485 communication system utilizing a proprietary protocol referred to as the BMS bus. Devices utilizing this RS-485 communication bus generally require less connections and can communicate more information remotely.

If remote indicators are utilized with the LIM2010, certain instructions may change based on whether the remote has or does not have RS-485 capability. Ensure that you are following the proper instructions when wiring and setting up the device.

Remotes with no bus capability: MK2000(C)(P) series (any combination)

Remotes with bus capability: MK2000CBM, MK2430, MK800

For more information on this topic, refer to the wiring diagram specific to the utilized remote indicator.

This page intentionally left blank.

2. Safety Instructions



DANGER

Hazard of Electric Shock, Burn, or Explosion

Only qualified maintenance personnel shall operate or service this equipment. These instructions should not be viewed as sufficient for those who are not otherwise qualified to operate or service this equipment. This document is intended to provide accurate information only. No responsibility is assumed by BENDER for any consequences arising from use of this document.

Turn OFF all sources of electric power before performing any inspections, tests, or service on this equipment. Assume all circuits are live until they have been properly de-energized, tested, grounded, and tagged. Failure to observe these precautions will result in equipment damage, severe personal injury, or death.

Proper operation of this equipment depends on proper installation. Refer to NFPA 99, NFPA 70E, CSA Z32, and other relevant standards and codes for installation standards. Neglecting fundamental installation techniques will result in equipment damage, severe personal injury, or death.

Do not make any modifications to the equipment. Failure to observe this precaution will result in equipment damage or personal injury.

Use only manufacturer's and manufacturer recommended accessories with this equipment. Failure to do so may damage the equipment beyond repair.

This page intentionally left blank.

3. Installation and Connection

3.1 LIM2010 Mounting and Dimensions

The front plate provides four holes with a diameter of 1/8" (3.2 mm) for screw mounting. Use the four provided mounting screws. Use minimum 2.6 lb-in (0.3 N-m), maximum 3.5 lb-in (0.4 N-m) tightening torque. Before mounting, plug the connector plate into the LIM2010.

Dimensions shown below are in inches (mm).

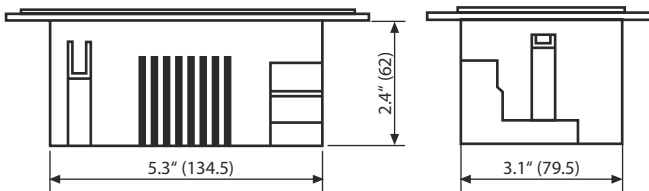
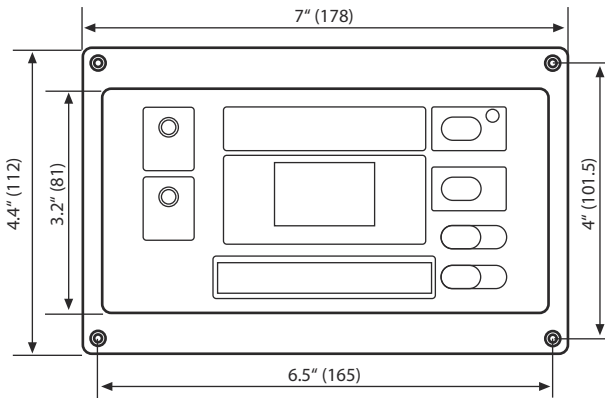

3.2 Wiring

The LIM2010 connects to a connector plate assembly. Follow these instructions to ensure proper connection and installation of the Line Isolation Monitor.

Remotes that are labeled as having “bus capability” have the ability to connect to the LIM2010 via a two-way RS-485 communication protocol.

DANGER

When applying power to the LIM, do not apply a voltage higher than 240 VAC. Failure to observe this precaution will result in equipment damage, severe personal injury, or death.

- Locate the proper wiring diagram from the table below. Note which remote indicator has been supplied with the LIM2010. Wiring instructions vary based on this combination.
- Before mounting the LIM, plug the connector plate into the LIM2010.
- Make the connections according to the respective wiring diagram.
- Turn ON power to the LIM2010. If no error messages are displayed, the LIM2010 is operating properly. Refer to section 4 for more detailed information.

Remote	Bus Compatible	Wiring Diagram
No remote	-	page 15
MK2000	-	page 18
MK2000C	-	page 19
MK2000P	-	page 20
MK2000CP	-	page 21
MK2000CBM	-	page 22

For connecting to MK2430 or MK800 remote indicating stations, refer to their respective user manuals for more information. Refer to Section 3.3 for making RS-485 connections to the LIM2010.

NOTE: The connector plate must be installed in a grounded, metallic enclosure.

3.2.1 BATTERY LOW Error on Initial Startup

Upon energizing the LIM2010 for the first time, a "BATTERY LOW" error message may appear. To clear this error, set the date and time on the device by referring to section 4.6.15, "Menu: SETTING / CLOCK." This will clear the error. The internal battery used for clock management will charge during normal operation.

3.2.2 Connector plate CP-LIM2010: Diagram

NOTE: The connector plate must only be installed in a grounded, metallic enclosure.

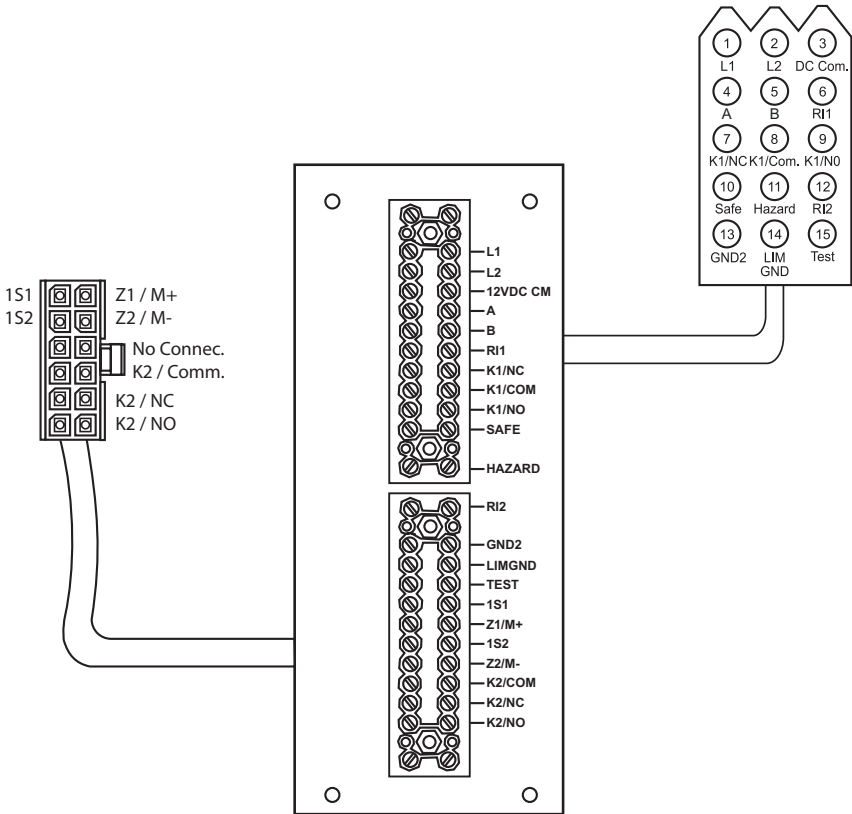

Terminal legend is found on the following page.

3.2.3 Connector Plate CP-LIM2010: Terminal Legend

Terminal(s)	Description
L1, L2	Connection to the isolated power system conductors.
12 VDC Com.	Common connection for MK2000 series remotes, up to 4
A, B	RS-485 interface used with BENDER communication bus Connection for MK2000CBM remote indicator
RI1	+ 12 V connection for test button for MK2000P series remotes Supply voltage connection for MK2000CBM remote indicator
K1/NC K1/Common K1/NO	N/C contact for alarm relay K1 Common contact for alarm relay K1 N/O contact for alarm relay K1
Safe	Normal condition signal for MK2000(C)(P) series remotes
Hazard	Alarm condition signal for MK2000(C)(P) series remotes
RI2	MUTE function for MK2000(C)(P) series remotes
GND2 LIM GND	Separate connections to ground
TEST	Connection for testing LIM2010 from MK2000P series remotes
K2/NC K2/Common K2/NO	N/C contact for alarm relay K2 Common contact for alarm relay K2 N/O contact for alarm relay K2
1S1, 1S2	Connection for load monitoring current transformer Use only these types: STW3, STW4, SWL-100A
Z1/M+ Z2/M-	Connections for overtemperature sensor OR Connection to external analog meter for THC measurements

3.2.4 Terminal RI2 For Remote Annunciation

Remote indicators that do not have bus capability may be muted collectively by connecting terminals 7 and 8 on the remote to terminal RI2 on the LIM2010. Regardless of wiring configuration, each respective device is able to mute itself. Wiring between the remote and the LIM2010 will affect whether a particular device will mute more than just itself. Refer to the table below for details.

LIM2010	MK2000 (C) (P)		
Terminal RI2	Terminal 7	Terminal 8	Mute Function
-	-	-	Only the local device will be muted
X	X	-	LIM mute button mutes both LIM and remote
X	-	X	Remote mute button mutes both LIM and remote
X	X	X	Both mute buttons will mute both devices

X = Terminal connected

3.2.5 Wiring Diagram: LIM2010, No Remote

No remote indication is provided with this connection method.

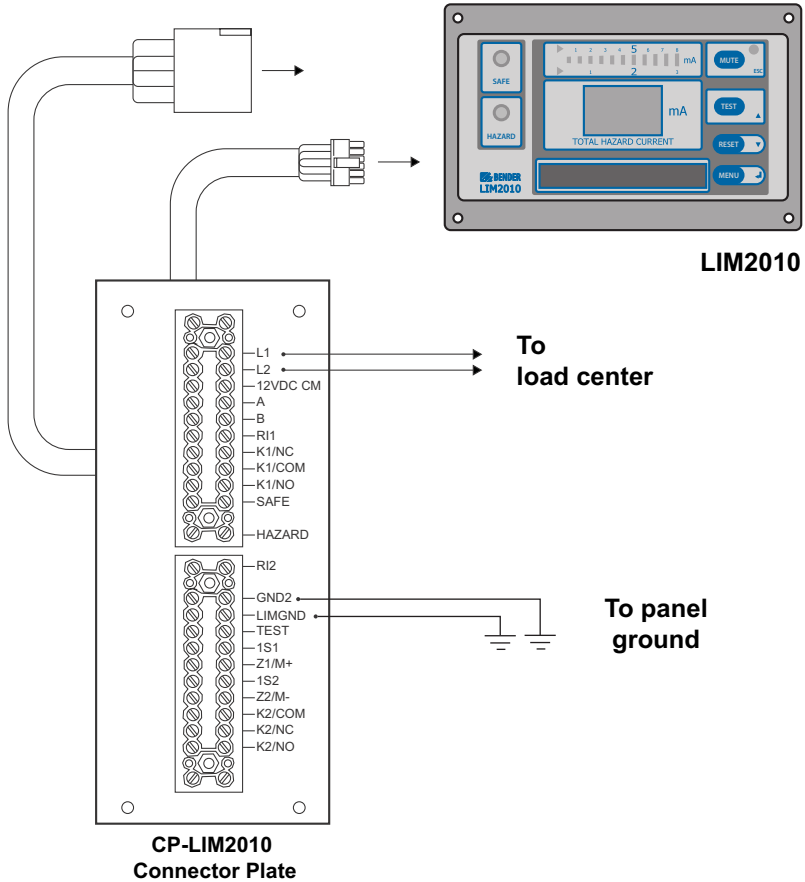

Connection Notes:

- Connector plate L1 and L2 connect to the main system conductors.
- Connector plate LIMGND and GND2 are SEPARATE connections to the system ground.

3.2.6 Wiring Diagram: Adding Load Monitoring

Additional wiring is required for adding load monitoring capabilities. Connections shown below are in addition to the connections required in section 3.2.5 on the previous page.

The line conductor must be routed centrally and at a right angle through the load monitoring current transformer.

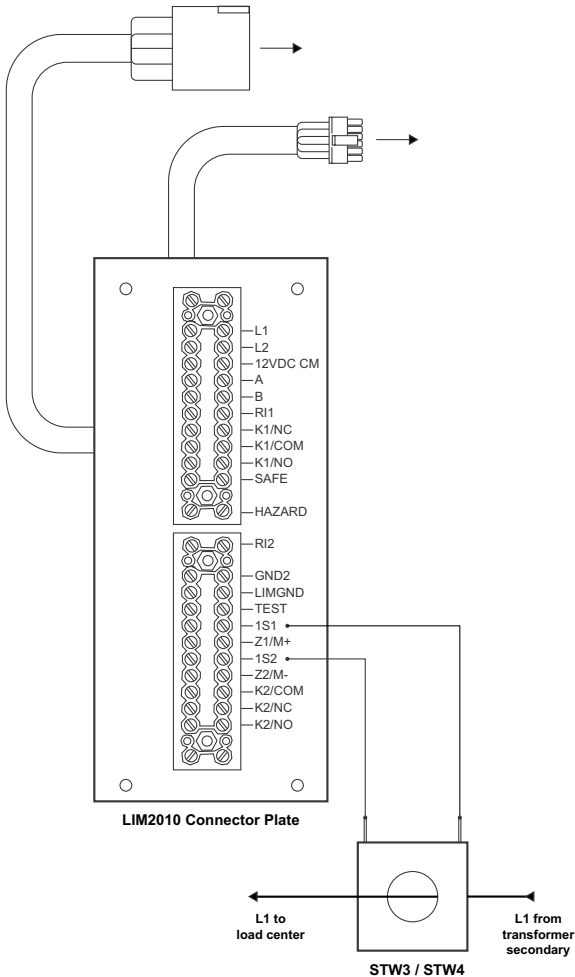

3.2.7 Wiring Diagram: Adding Ground Fault Location

Adding ground fault location requires the following modules:

- EDS461-D-2 ground fault location module. Each module monitors up to twelve (12) branches - monitoring additional branches requires additional modules.
- W10-8000 current transformer (one required per branch)

OR

- EDS151 ground fault location module. EDS151 modules have integrated current transformers. One module can monitor up to six (6) separate branches. Monitoring additional branches requires additional EDS151 modules.
- MK2430 or MK800 remote indicating station. Only one required even if multiple location modules are utilized.

Ground fault location modules connect to the system's LIM2010 via the BENDER RS-485 communication bus. Multiple ground fault location modules may be connected to a single LIM2010. For more information on connecting RS-485 communicating equipment to the LIM2010, refer to section 3.3.

For information on installing ground fault location modules, refer to the respective EDS461 / EDS151 user manuals.

3.2.8 Wiring Diagram: LIM2010 and MK2000

This remote provides a SAFE LED, a HAZARD LED, and a mute button / LED.

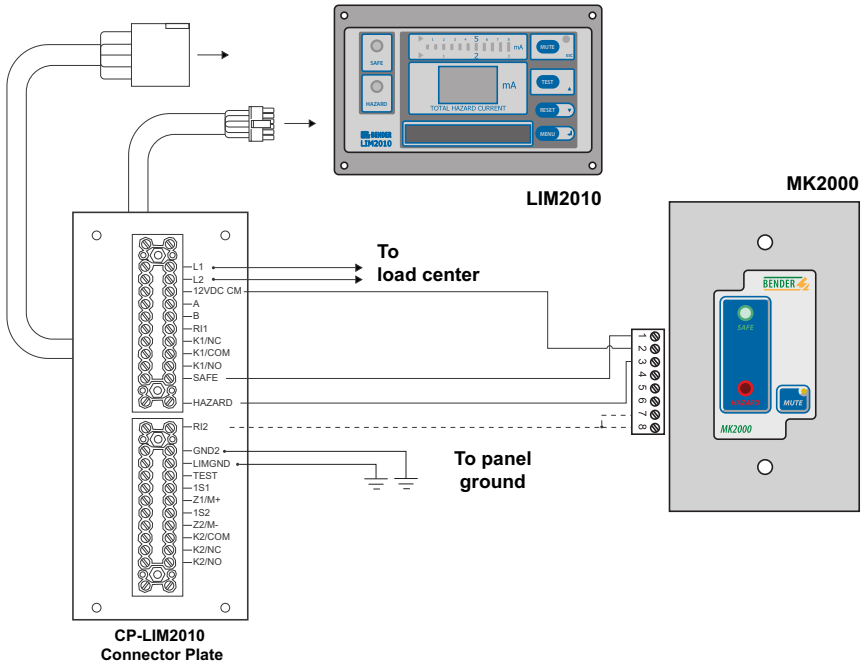

Connection Notes:

- Connector plate L1 and L2 connect to the main system conductors.
- Connector plate LIMGND and GND2 are SEPARATE connections to the system ground.
- Connector plate Safe, Hazard, and 12 VDC COM connect to the respective terminals on the remote.
- Connector plate RI2 connection is required for system muting.

3.2.9 Wiring Diagram: LIM2010 and MK2000C

This remote provides a SAFE LED, a HAZARD LED, a transformer overload LED, and a mute button / LED.

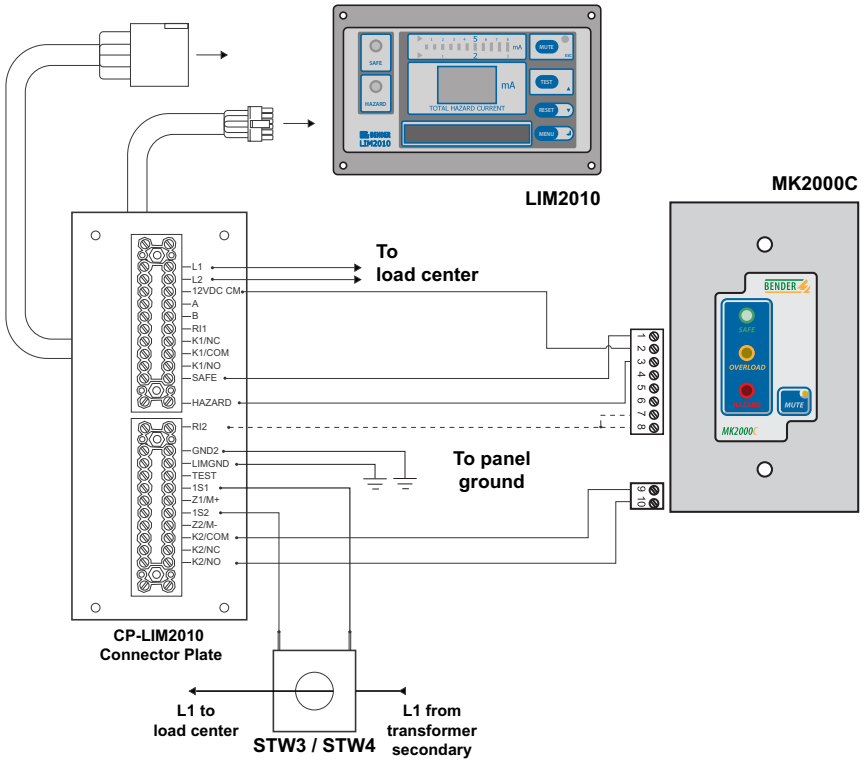

Connection Notes:

- Connector plate L1 and L2 connect to the main system conductors.
- Connector plate LIMGND and GND2 are SEPARATE connections to the system ground.
- Connector plate Safe, Hazard, and 12 VDC COM connect to the respective terminals on the remote.
- Connector plate RI2 connection is required for system muting.
- For load monitoring, only current transformer types STW3, STW4, and SWL-100A may be used.
- The factory setting in the LIM2010 for the current transformer is STW3.

3.2.10 Wiring Diagram: LIM2010 and MK2000P

This remote provides a SAFE LED, a HAZARD LED, a mute button / LED, and a remote test button.

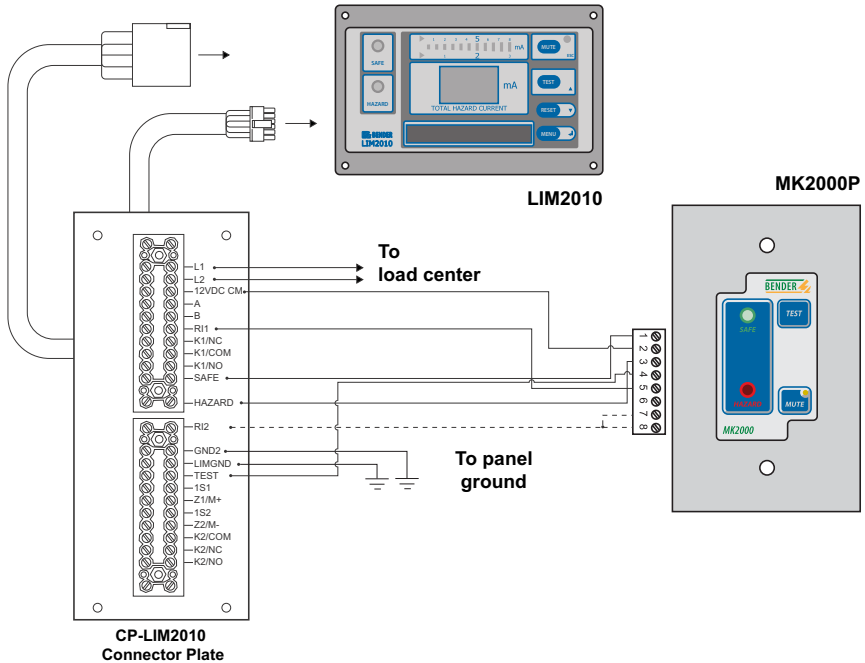

Connection Notes:

- Connector plate L1 and L2 connect to the main system conductors.
- Connector plate LIMGND and GND2 are SEPARATE connections to the system ground.
- Connector plate Safe, Hazard, and 12 VDC COM connect to the respective terminals on the remote.
- Connector plate RI2 connection is required for system muting.
- Connector plate Test and RI1 are required for remote test function.

3.2.11 Wiring Diagram: LIM2010 and MK2000CP

This remote provides a SAFE LED, a HAZARD LED, a transformer overload LED, a mute button / LED, and a remote test button.

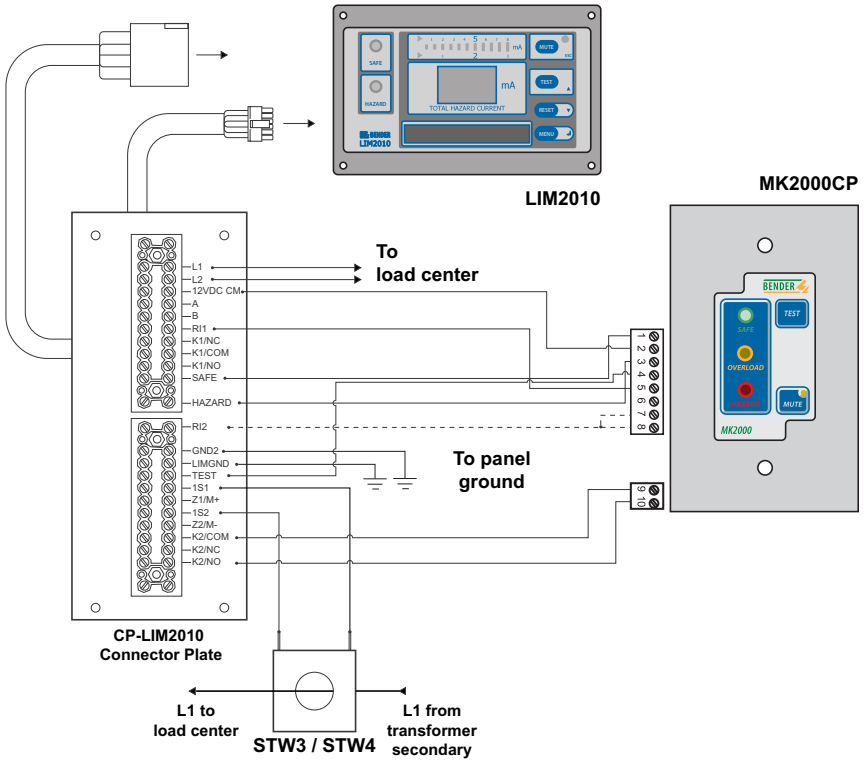

Connection Notes:

- Connector plate L1 and L2 connect to the main system conductors.
- Connector plate LIMGND and GND2 are SEPARATE connections to the system ground.
- Connector plate Safe, Hazard, and 12 VDC COM connect to the respective terminals on the remote.
- Connector plate RI2 connection is required for system muting.
- Connector plate Test and RI1 are required for remote test function.
- For load monitoring, only current transformer types STW3, STW4, and SWL-100A may be used.
- The factory setting in the LIM2010 for the current transformer is STW3.

3.2.12 Wiring Diagram: LIM2010 and MK2000CBM

This remote provides a SAFE LED, a HAZARD LED, a transformer overload LED, a mute button / LED, a remote test button, and two digital displays showing Total Hazard Current and transformer overload.

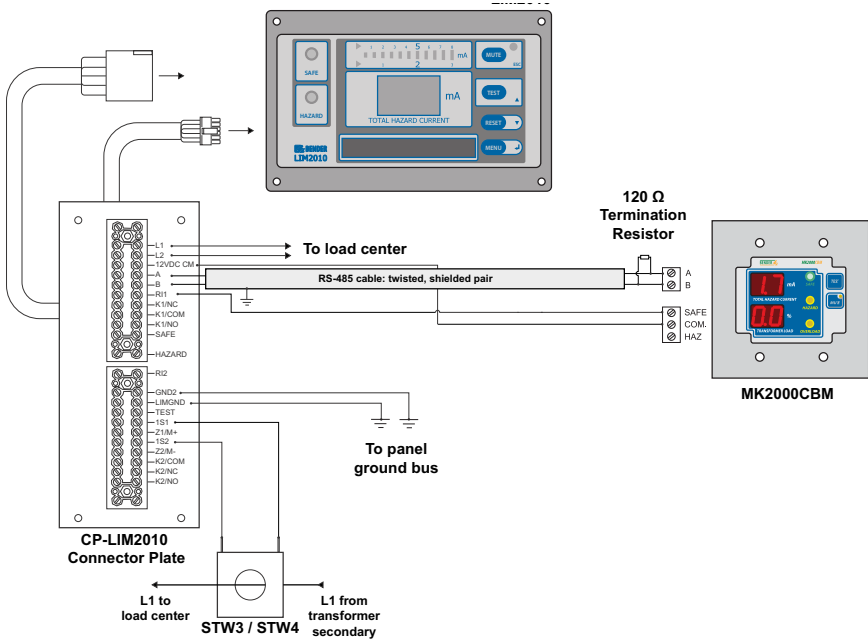

Connection Notes:

- Connector plate L1 and L2 connect to the main system conductors.
- Connector plate LIMGND and GND2 are SEPARATE connections to the system ground.
- Connector plate Safe, Hazard, and 12 VDC COM connect to the respective terminals on the remote.
- Connector plate RI2 connection is required for system muting.
- Connector plate Test and RI1 are required for remote test function.
- For load monitoring, only current transformer types STW3, STW4, and SWL-100A may be used.
- The factory setting in the LIM2010 for the current transformer is STW3.
- Refer to Section 3.3 for additional requirements for setting up a BENDER RS-485 communication bus.

3.3 RS-485 Bus Topology and Termination

NOTE: This section only applies when one or more of the following devices are utilized in combination with the LIM2010:

- Remote indicators with bus capability
- Ground fault location modules

For communication purposes, devices are connected to each other in an RS-485 chain. A topology example is given below. Use AWG 20 RS-485 cable. Node limits and cable distances according to RS-485 standards apply.

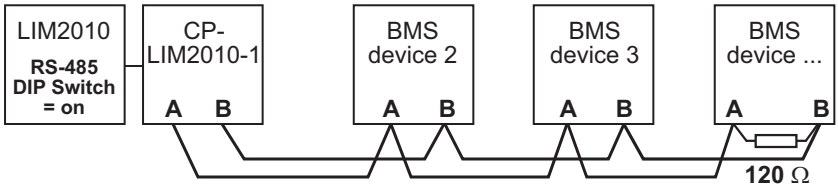

Each device requires a unique address on the BENDER communication bus. Refer to section 4.6.XX for changing this setting on the LIM2010. For other devices, refer to their respective user manual.

Devices at the beginning and end of the chain require termination. Termination is accomplished by either placing a 120 ohm resistor across terminals A and B, or changing the R_{on} DIP switch to ON (if it is available).

If the LIM2010 is at the beginning or end of the RS-485 chain, change the R_{on} DIP switch shown below to ON. Otherwise, change it to OFF.

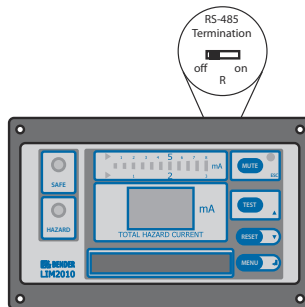

4. Operating and Settings

4.1 Front Panel Display - Normal Condition

The illustration below shows the LIM2010 in the system normal condition, with all possible indications.

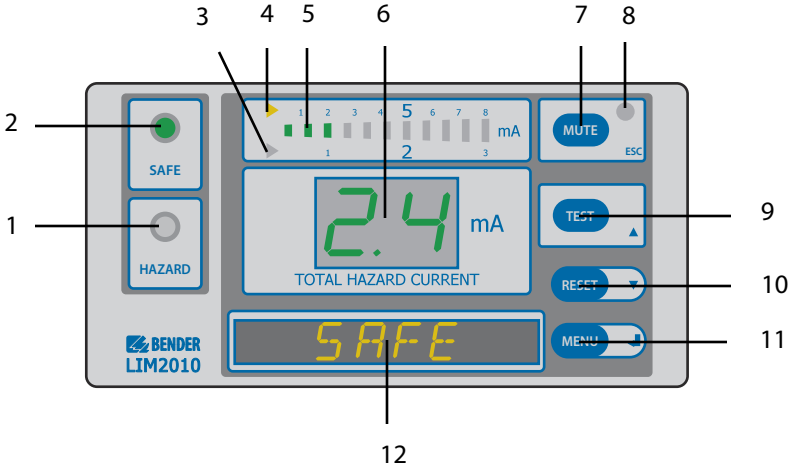

1	HAZARD LED (red): Not illuminated.
2	SAFE LED (green): Illuminated. Will be in system normal condition when the displayed Total Hazard Current is below the response value (2 mA or 5 mA).
3	2 mA response value indicator: Illuminates when the 2 mA response value has been activated.
4	5 mA response value indicator: Illuminates when the 5 mA response value has been activated.
5	LED bar graph: In the system normal condition, only the green bars are illuminated.
6	Seven-segment THC display: Displays the measured Total Hazard Current. In the system normal condition, the display is green in color.

7	MUTE button ESC key: Moves back an option in the built-in menu.
8	Mute LED: Not illuminated in the system normal condition.
9	TEST Button: Activates the built-in self-test. UP key: Moves up in the menu and decreases values where applicable.
10	DOWN key: Moves down in the menu and increases values where applicable.
11	MENU key: Enters the main menu. ENTER key: Confirms settings and entries.
12	Digital display: Reads SAFE in the system normal condition. When in the menu, displays menu options.

4.2 Front Panel Display - Alarm Condition

When the measured Total Hazard Current exceeds the set response value (2 mA or 5 mA), the LIM2010 will go into the alarm condition. When this occurs, the audible alarm will sound, as well as the following:

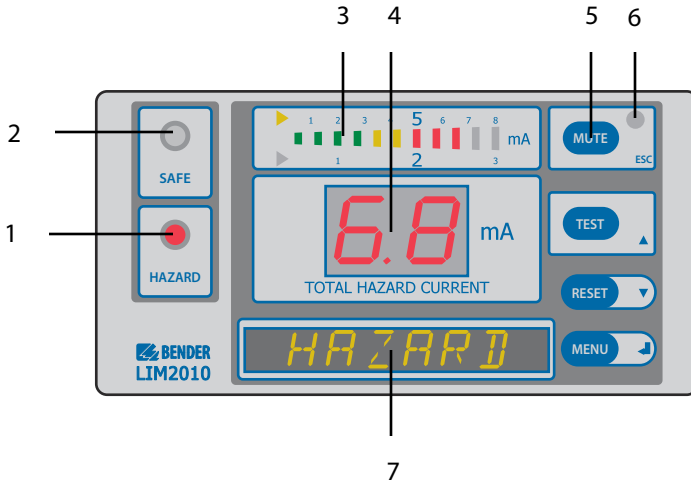

1	HAZARD LED (red): Illuminates.
2	SAFE LED (green): No longer illuminated.
3	LED bar graph: In the alarm condition, the red bars will illuminate.
4	Seven-segment THC display: Displays the measured Total Hazard Current. In the alarm condition, the display is red in color.
5	MUTE button: Pressing the MUTE button will silence the audible alarm and activate the yellow MUTE LED.
6	MUTE LED: Will illuminate after the MUTE button is pressed.
7	Digital display: Reads HAZARD in the alarm condition.

4.3 Displaying Measured Values

The Total Hazard Current is displayed in real-time on the numeric display in the middle of the frontplate. For retrieving other measured values, such as load current or impedance, refer to the menu item "1.Values." For details about the submenu VALUES, refer to section 4.6.5.

4.4 Procedure for Functional Test of LIM2010

The LIM2010 may be tested while the isolated power system is online. Press the TEST button for approximately two seconds to begin the functional test. The following will occur:

- The entire LED bar graph will illuminate.
- The digital display at the bottom of the frontplate will display ****TEST****.
- The digital display will flash.
- The audible buzzer will sound.
- The HAZARD LED will illuminate.
- If no fault is present in the system, the text *****OK***** will appear on the digital display. The device will then return to the system normal condition. The text ****SAFE**** will display on the digital display and the SAFE LED will illuminate.

BENDER recommends pressing the TEST button at least monthly to ensure proper operation of the LIM2010.

4.5 Factory Settings

Parameter Type	Menu Item		Value Options	Default
Total Hazard Current	GENERAL	THC	2 mA, 5 mA	5 mA
Current Transformer Type	GENERAL	CT	off, STW3, STW4, SWL	off
Maximum Load Current	GENERAL	LOAD	off, 10 A - 200 A	off
Undervoltage	GENERAL	U<	off, 80 V - 300 V	off
Overvoltage	GENERAL	U>	off, 80 V - 300 V	off
Isolation Impedance	GENERAL	Z	off, 10k - 200k	off
Isolation Resistance	GENERAL	R	off, 20k - 200k	off
Temperature Monitoring	GENERAL	TEMP	off, on	off
Fault Location	GENERAL	F.LOC	off, auto	off
Response Delay t_{on}	GENERAL	T.on	0 - 99 s	0 s
Release Delay t_{off}	GENERAL	T.off	0 - 99 s	0 s
Test Cycle	GENERAL	TEST	1 h - 24 h	1 hr
Relay 1 Operation	REL. NO. 1		N/O, N/O-T, N/C, N/C-T	N/C-T
Relay 1 Alarm THC	REL. NO. 1	THC	off, on	on
Relay 1 Alarm Overload	REL. NO. 1	LOAD	off, on	off
Relay 1 Alarm Undervoltage	REL. NO. 1	U<	off, on	off
Relay 1 Alarm Overvoltage	REL. NO. 1	U>	off, on	off
Relay 1 Alarm Impedance	REL. NO. 1	Z	off, on	off
Relay 1 Alarm Resistance	REL. NO. 1	R	off, on	off
Relay 1 Alarm Temperature	REL. NO. 1	TEMP	off, on	off
Relay 1 Alarm Device Error	REL. NO. 1	SYS	off, on	off
Relay 2 Operation	REL. NO. 2		N/O, N/O-T, N/C, N/C-T	N/C-T
Relay 2 Alarm THC	REL. NO. 2	THC	off, on	off





Parameter Type	Menu Item		Value Options	Default
Relay 2 Alarm Overload	REL. NO. 2	LOAD	off, on	on
Relay 2 Alarm Undervoltage	REL. NO. 2	U<	off, on	on
Relay 2 Alarm Overvoltage	REL. NO. 2	U>	off, on	on
Relay 2 Alarm Impedance	REL. NO. 2	Z	off, on	on
Relay 2 Alarm Resistance	REL. NO. 2	R	off, on	on
Relay 2 Alarm Temperature	REL. NO. 2	TEMP	off, on	on
Relay 2 Alarm Device Error	REL. NO. 2	SYS	off, on	on
Buzzer Volume	BUZZER	VOL	High, Low	High
System Mute	BUZZER	SY.MU	off, on	on
Buzzer Alarm Overload	BUZZER	LOAD	off, on	on
Buzzer Alarm Undervoltage	BUZZER	U<	off, on	on
Buzzer Alarm Overvoltage	BUZZER	U>	off, on	on
Buzzer Alarm Impedance	BUZZER	Z	off, on	on
Buzzer Alarm Resistance	BUZZER	R	off, on	on
Buzzer Alarm Temperature	BUZZER	TEMP	off, on	on
Buzzer Alarm Device Error	BUZZER	SYS	off, on	on
Data Log. Chan. THC Change	DATALOG	CHAN.THCH	0% - 100%	10%
Data Log. Chan. THC O/W	DATALOG	CHAN.THCH	no, yes	no
Data Log. Chan. U.12 Change	DATALOG	CHAN.U.12	0% - 100%	10%
Data Log. Chan. U.12 O/W	DATALOG	CHAN.U.12	no, yes	no
Data Log. Chan. U.1E Change	DATALOG	CHAN.U.1E	0% - 100%	10%
Data Log. Chan. U.1E O/W	DATALOG	CHAN.U.1E	no, yes	no
Data Log. Chan. U.2E Change	DATALOG	CHAN.U.2E	0% - 100%	10%
Data Log. Chan. U.2E O/W	DATALOG	CHAN.U.2E	no, yes	no
Data Log. Chan. Z Change	DATALOG	CHAN.Z	0% - 100%	10%
Data Log. Chan. Z O/W	DATALOG	CHAN.Z	no, yes	no

Parameter Type	Menu Item		Value Options	Default
Data Log. Chan. R Change	DATALOG	CHAN.R	0% - 100%	10%
Data Log. Chan. R O/W	DATALOG	CHAN.R	no, yes	no
Data Log. Chan. I.1 Change	DATALOG	CHAN.I.1	0% - 100%	10%
Data Log. Chan. I.1 O/W	DATALOG	CHAN.I.1	no, yes	no
Data Log. Chan. I.2 Change	DATALOG	CHAN.I.2	0% - 100%	10%
Data Log. Chan. I.2 O/W	DATALOG	CHAN.I.2	no, yes	no
Data Log. Chan. I.3 Change	DATALOG	CHAN.I.3	0% - 100%	10%
Data Log. Chan. I.3 O/W	DATALOG	CHAN.I.3	no, yes	no
RS-485 (BMS) Bus Address	INTRFCE	ADR.	1 - 90	1 (Master)
Daylight Savings Time Change	CLOCK	DST	off, auto	auto
Password	PASSWRD	PSWD***	0 - 999	807
Password Status (Lock)	PASSWRD	LOCK	off, on	on

4.6 LIM2010 Main Menu

4.6.1 Operating Elements and Displays

The displays and operating elements shown in the table below are used to carry out settings in the main menu.

	<p>MENU: Enters the main menu ENTER: Selection of next menu level, confirms entries</p>
	<p>UP key: Moves up in the menu and increases values where applicable</p>
	<p>DOWN key: Moves down in the menu and decreases values where applicable</p>
	<p>ESC key; Moves back a menu level and cancels entered values where applicable</p>
	<p>Display for menu options and values</p>

4.6.2 Navigation Through the Menu

Accessing the main menu

Hold the MENU button for at least one second. The device will enter into menu mode. The first item in the menu, "VALUES," will appear. The number "1" will flash.

Entering the password prior to menu navigation

Most menu options are password protected. Follow the below procedure to enter the password:

- A flashing number indicates the current focus.
- Use the UP/DOWN keys to select the first correct number.
- Confirm with the ENTER key.
- Repeat until the last number is confirmed.
- Settings may be modified without entering the password until the main menu is exited. Entering the menu after exiting will require a re-entry of the password.

4.6.3 Menu Structure

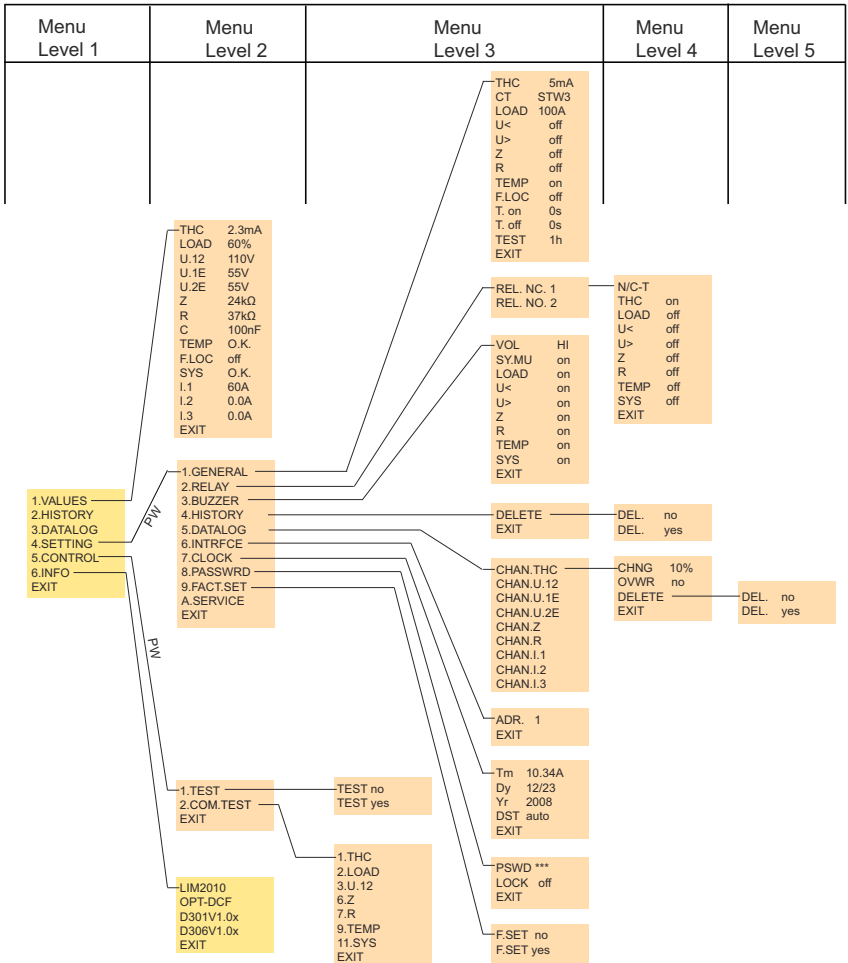

PW = Password protected

4.6.4 Main Menu

To go back a step in the menu, press the MUTE/ESC key.

	MENU Level 1	Description	Page
	EXIT		
	1. VALUES	Display all measured values in real-time	XX
	2. HISTORY	Display history of alarm messages	XX
	3. DATALOGGER	Data logging of selected parameters	XX
	4. SETTING	Change settings	XX
	5. CONTROL	Begin BMS or device test	XX
	6. INFO	Display device information	XX
	EXIT		

4.6.5 Menu: VALUES

This menu indicates the values being measured in real-time.

MENU Level 1	MENU Level 2	Description
	EXIT	
1. VALUES	THC 2.3mA	Total Hazard Current
	LOAD 60%	Max. load current [%]
	U.12 110V	Voltage between L1 and L2
	U.1E 55V	Voltage between L1 and ground
	U.2E 55V	Voltage between L2 and ground
	Z 24kΩ	Isolation impedance
	R 37kΩ	Isolation resistance
	C 100nF	Leakage capacitance
	TEMP O.K.	Transformer temperature indication
	F.LOC off	Status of the location test generator
	SYS O.K.	Status of the device
	I.1 60A	Load current measured from CT 1
	I.2 0.0A	Load current measured from CT 2
	I.3 0.0A	Load current measured from CT 3
	EXIT	

4.6.6 Menu: HISTORY

This option displays a record of timestamped alarms. After opening the menu option, the most recent alarm will appear. Pressing the UP and DOWN keys will scroll through the information available. Pressing the ENTER key again will display additional information regarding the alarm.

MENU Level 1	MENU Level 2	MENU Level 3	Description
		EXIT	
2. HISTORY	AL125. THC	START.THC	THC alarm with the consecutive number 125/Start of the alarm:
		10 / 24 / 09	Date
		11.45 am	Time
		QUIT.THC	Mute of the alarm:
		10 / 24 / 09	Date
		11.45 am	Time
		END.THC	End of the alarm:
		10 / 25 / 09	Date
		9.30 am	Time
		MIN. 6.0mA	Min. value of THC
		MAX. 9.9mA	Max. value of THC
		EXIT	

4.6.7 Menu: DATALOG (Logging for up to 300 data points)

MENU Level 1	MENU Level 2	MENU Level 3	Description
		EXIT	
3. DATALOG	CHAN. THC	289.THC 2mA	Last value change
		11 / 30 / 09	Date
		03.45 am	Time
		288.THC 4mA	2nd to last value
		09 / 15 / 09	Date
		11.14 am	Time
	
	
	
		1.THC 1mA	First stored value
		05 / 23 / 09	Date
		11.55 am	Time
		EXIT	

4.6.8 Menu: SETTING

WARNING

Only qualified maintenance personnel shall modify these settings. Improper settings may render the LIM2010 inoperable, cause damage to equipment, or cause personal injury.

MENU Level 1	MENU Level 2	Description
	EXIT	
4. SETTING	1. GENERAL	Change response values
	2. RELAY	Change relay operation
	3. BUZZER	Change buzzer settings
	4. HISTORY	Erase history memory
	5. DATALOG	Set logging parameters
	6. INTERFACE	Change the LIM bus address
	7. CLOCK	Change time and date
	8. PASSWORD	Enable/disable/change the password
	9. FACT.SET	Reset to factory defaults
	A. SERVICE	Only for manufacturer service
	EXIT	

4.6.9 Menu: SETTING/GENERAL

Changes to the response values, such as THC, load monitoring, undervoltage, etc. are made here. All alarms except THC may be turned ON or OFF along with any other alarm settings made.

MENU Level 1	MENU Level 2	MENU Level 3	Description
		EXIT	
4. SETTING	1. GENERAL	THC 2mA	Total Hazard Current: 2mA / 5mA
		CT off	Current transformer type: off / STW3 / STW4 / SWL
		LOAD off	Load current: off, 10...200A
		U< off	Undervoltage: off, 80...300V
		U> off	Overvoltage: off, 80...300V
		Z off	Isolation impedance: off, 10...200kΩ
		R off	Isolation resistance: off, 20...200kΩ
		TEMP off	Transformer temperature control: off / on (off = current output, refer to)
		F.LOC off	Start and stop conditions for EDS systems: test current generator off / auto
		T.ON 0s	Response delay: 0...99s
		TOFF 0s	Release delay: 0...99s
		TEST 1h	Self test interval: 1...24h
		EXIT	

4.6.10 Menu: SETTING/RELAY

Settings related to the contact outputs are modified in this menu option. Each type of alarm may be assigned to switch one or both of the two available output contacts. If an alarm is set to ON in this menu option, it will change the state of the applicable contact. If it is set to OFF, then it will not change the state of the contact. Additionally, the operation of the contact may be changed here. The following notes the options available and their meaning:

- N/C mode: "Failsafe" or "Normally energized" mode. The LIM2010 will switch the contact in the event of an alarm or loss of power to the device.
- N/C-T mode: "Failsafe" or "Normally energized" mode with test enabled. The LIM2010 will switch the contact in the event of an alarm, loss of power to the device, or during a self-test.
- N/O mode: "Non-failsafe" or "Normally de-energized" mode. The LIM2010 will switch the contact only in the event of an alarm.
- N/O-T mode: "Non-failsafe" or "Normally de-energized" mode with test enabled. The LIM2010 will switch the contact in the event of an alarm or during a self-test.

MENU Level 1	MENU Level 2	MENU Level 3	MENU Level 4	Description
			EXIT	
4. SETTING	2. RELAY	REL. NO. 1	N/C-T	"Failsafe" operation: The contact will trip in the event of an alarm, a test, or a loss of power to the device.
			THC on	Relay 1 switches when a THC alarm occurs
			LOAD off	Relay 1 does not switch in the event of a LOAD alarm
			U< off	Relay 1 does not switch in the event of an undervoltage alarm
			U> off	Relay 1 does not switch in the event of an overvoltage alarm
			Z off	Relay 1 does not switch in the event of an insulation impedance alarm
			R off	Relay 1 does not switch in the event of an insulation resistance alarm
			TEMP off	Relay 1 does not switch in the event of a temperature alarm
			SYS off	Relay 1 does not switch in the event of a device error
			EXIT	

4.6.11 Menu: SETTING/BUZZER

Settings here relate to the audible alarm buzzer. If a type of alarm is set to ON, it will activate the audible alarm in the event of an alarm. If it is set to OFF, it will not activate the audible alarm.

MENU Level 1	MENU Level 2	MENU Level 3	Description
		EXIT	
4. SETTING	3. BUZZER	VOL HI	Buzzer volume: High or Low
		SY.MU on	System mute: on/off
		LOAD on	Buzzer sounds in the event of an LOAD alarm
		U< on	Buzzer sounds in the event of an under-voltage alarm
		U> on	Buzzer sounds in the event of an over-voltage alarm
		Z on	Buzzer sounds in the event of an insulation impedance alarm
		R on	Buzzer sounds in the event of an insulation resistance alarm
		TEMP on	Buzzer sounds in the event of an temperature alarm
		SYS on	Buzzer sounds in the event of an device error
		EXIT	

4.6.12 Menu: SETTING/HISTORY

Selecting YES will erase the history of alarms on the device. Once it is erased, the history cannot be recovered.

MENU Level 1	MENU Level 2	MENU Level 3	MENU Level 4	Description
		EXIT		
4. SETTING	4. HISTORY	DELETE	DEL. no	Erase history memory: yes or no
		EXIT		

4.6.13 Menu: SETTING/DATALOG

This menu controls how often data is recorded in the history of the LIM2010. The number of records is controlled by changing the minimum percentage difference between two values to warrant recording to the history.

Example: If the “CHNG” item is set to 10%, a difference of 10% between the currently read value and the previous one will record an event to the history log.

MENU Level 1	MENU Level 2	MENU Level 3	MENU Level 4	MENU Level 5	Description
			EXIT		
4. SETTING	5. DATALOG	CHAN. THC	CHNG 10%		Change in limiting value: 5...100 %
		CHAN. U.12	OVWR no		Overwrite full memory: yes or no
		CHAN. U.1E	DELETE	DEL no	delete data logger: yes or no
		CHAN. U.2E	EXIT		
		CHAN. Z			
		CHAN. R			
		CHAN. I.1			
		CHAN. I.2			
		CHAN. I.3			

4.6.14 Menu: SETTING/INTERFACE (Bus Address)

Use this menu option to set the unique address for the RS-485 communication bus. In most cases, this option should be set to 1 (Master).

MENU Level 1	MENU Level 2	MENU Level 3	Description
		EXIT	
4. SETTING	6. INTRFCE	ADR. 1	setting range: 1...90
		EXIT	

4.6.15 Menu: SETTING/CLOCK

Settings here relate to the time and date. If, upon powering the LIM2010 for the first time, a BATTERY LOW error appears, setting the date and time here and allowing the device to run in normal operation will clear the error.

MENU Level 1	MENU Level 2	MENU Level 3	Description
		EXIT	
4. SETTING	7. Clock	Tm 10.34A	Time: am/pm
		Dy 12/23	Date: month/day
		Yr 2009	Year
		DST auto	Daylight saving time: auto/off (North America time zones only)
		EXIT	

4.6.16 Menu: SETTING/PASSWORD

MENU Level 1	MENU Level 2	MENU Level 3	Description
		EXIT	
4. SETTING	8. PASSWRD	PSWD ***	Password range: 000...999 Factory setting 807
		LOCK off	Password protection activated (on) or deactivated (off)
		EXIT	

4.6.17 Menu: SETTING/FACTORY SETTING

This menu option will reset the device to factory defaults. Once reset, it cannot be restored to its previous state automatically. Any changes must be re-entered.

MENU Level 1	MENU Level 2	MENU Level 3	Description
4. SETTING	9. FACT.SET	F.SET no	Factory setting deactivated
		F.SET yes	Factory setting will be restored

4.6.18 Menu: SETTING/SERVICE

This menu is for manufacturer service only.

4.6.19 Menu: CONTROL/TEST

Setting this menu option to “yes” will allow connected remote indicators with bus capability to initiate a self-test on the LIM2010 when the TEST button is pressed on the respective remote indicator.

MENU Level 1	MENU Level 2	MENU Level 3	Description
5. CONTROL	1. TEST	TEST no	test deactivated
		TEST yes	Test will be activated

4.6.20 Menu: CONTROL/COMMUNICATION TEST

This menu option enables testing of the RS-485 communication bus between the LIM2010 and other bus-compatible devices.

MENU Level 1	MENU Level 2	MENU Level 3	Description
		EXIT	
5. CONTROL	2. COM.TEST	1.THCH	Sending THCH alarm message via BMS bus
		2.LOAD	Sending overload alarm message via BMS bus
		3.U.12	Sending overvoltage alarm message via BMS bus
		6.Z	Sending low impedance alarm message via BMS bus
		7.R	Sending low resistance alarm message via BMS bus
		9.TEMP	Sending overtemperature alarm message via BMS bus
		11.SYS	Sending system fault alarm message via BMS bus
		EXIT	

4.6.21 Menu: INFO

This menu option displays important information regarding the LIM2010's firmware.

MENU Level 1	MENU Level 3	Description
	EXIT	
6. INFO	LIM2010	Device type
	OPT -DCF	Option of the device
	D301 V1.0x	Software version of measurement technique
	D306 V1.0x	Communication software version
	EXIT	

5. Periodic Testing

BENDER recommends regular testing of the LIM2010 and the isolated power system it protects. Consult the manufacturer or a local representative for more information.

Additionally, BENDER recommends pressing the TEST button on the LIM2010 at least monthly to ensure proper operation of the Line Isolation Monitor.

6. Messages from the RS-485 Bus

6.1 Alarm Messages

Alarm messages are created when one or more of the alarms activate. Depending on the type of device, these may be alarm values, a device's status, or an error message. These messages are controlled by the device in the system designated as the master. For details about error codes, refer to section 7.4.

Channel	Description
1	Total hazard current, in mA
1	Bad ground connection
1	Bad system connection
2	Transformer overload, in %
2	Short circuit at CT connection
2	Bad CT connection
3	Undervoltage between L1 and L2, in V
3	Overvoltage between L1 and L2, in V
6	Impedance Z_F in $k\Omega$
7	Resistance R_F in $k\Omega$
9	Transformer overtemperature
10	Ground fault location in operation
11	Internal device error

6.2 Operating Status Messages

Operating status messages contain general status information about the system. These messages are continuously generated. These messages are interpreted by the device in the system designated as the master.

Channel	Description
1	Total hazard current, in mA
2	Transformer overload in %
3	Voltage between L1 and L2, in V
4	Voltage between L1 and Ground, in V
5	Voltage between L2 and Ground, in V
6	Impedance Z_F in $k\Omega$
7	Resistance R_F in $k\Omega$
8	Leakage capacitance in nF

7. Technical Data

7.1 LIM2010

()* = Factory Setting

Insulation coordination acc. to IEC 60664-1 / UL 1022

Rated insulation voltage AC 250 V

Rated impulse voltage / pollution degree..... 2.5 kV / III

Voltage test acc. to IEC 61010-1 and UL 1022 2.0 kV

Supply voltage

Supply voltage U_S = Nominal voltage U_n

Power consumption < 22 VA

Isolated Power System Ratings

Nominal voltage U_n AC 100 - 240 V

Operating range of U_n 85% - 110%

Rated frequency f_n 50/60 Hz

Operating range of f_n $\pm 5\%$

Insulation and THC Monitoring

Response value, THC 2 mA / 5 mA (5 mA)*

Response tolerance, THC 1.8 - 2 mA / 4.5 - 5 mA

Hysteresis, THC 20%

Response value, Z 10 - 200 k Ω (off)*

Response tolerance, Z $\pm 15\%$

Hysteresis, Z 25%

Response value, R 20 - 200 k Ω (off)*

Response tolerance, R $\pm 15\%$

Hysteresis, R 25%

Response time t_{an} < 4 s

Measuring Circuit

Measuring voltage U_m ± 48 V

Measuring current I_m (at $Z_F = 0$ ohm)..... < 32 μ A

Internal resistance ≥ 1.5 M Ω

Monitor Hazard Current MHC 120 V / 240 V 60 μ A / 95 μ A

EDS mode (fault location):

Monitor Hazard Current MHC..... < 950 μ A

Test cycle / idle time 2 s / 4 s

Voltage Monitoring

Response value, under/overvoltage (<U / >U) 80 - 300 V (off)*
 Response tolerance ± 3%
 Hysteresis 4 %

Load Current (Transformer Overload) Monitoring

Response value 10 - 200 A (off)*
 Response tolerance ± 5%
 Hysteresis 4 %

Temperature Monitoring

Response value 4 kΩ
 Release value 1.6 kΩ
 PTC resistor acc. to DIN 44081 max. 6 connected in series

Adjustable Time Delays (Do NOT Apply to THC Alarm)

Response delay t_{on} 0 - 99 s (0 s)*
 Delay on release t_{off} 0 - 99 s (0 s)*

Displays, Memory

14-segment display 8 digits, multifunctional
 Displayed measured value, THC 0.0 - 9.9 mA
 Operating uncertainty, THC ± 7% / ± 0.1 mA
 Measured value, load current (as % of response value) 10 - 199%
 Operating uncertainty, load current ± 5% / ± 0.2 A
 Measured value, line voltage 10 - 300 V
 Operating uncertainty, line voltage ± 5% / ± 2 V
 Measured value, impedance Z 0 - 1000 kΩ
 Operating uncertainty, impedance Z ± 5% / ± 1 kΩ
 Measured value, resistance R 2 - 1000 kΩ
 Operating uncertainty, Z ~ R ± 20% / ± 1 kΩ
 Measured value, leakage capacitance C 0 - 500 nF
 Operating uncertainty, Z ~ X_C ± 20% / ± 5 nF
 (No indication of R and C at Z < 2 kΩ)
 Measured value, load current 0.5 - 250 A
 Operating uncertainty, load current ± 5%, ± 0.2 A
 7-segment display 2 digits, digital THC indication
 Bar graph indicator analog THC indication
 History memory 300 event records
 Data logger 300 data records

Inputs / Outputs

Analog current output M+/M- 0 - 400 μ A
Operating uncertainty \pm 10%
Output RI1, 12VDC COM..... 12 V / 200 mA
RI2, SAFE, HAZARD, TEST..... max. qty. 4 MK2000(C)(P)
Cable lengthmax. 32 ft (10 m)

RS-485 Interface

Interface A-B / Protocol..... RS-485 / BMS (proprietary)
Baud rate.....9600 baud
Max. cable length without repeater..... 3900 ft (1200 m)
Recommended cable
(Shielded, twisted pair, 1 end grounded) J-Y(St)Y 2x0.8
Termination resistor..... 120 Ω (0.25 W), DIP switch activated (off)*
Device address, BMS bus..... 1 - 90 (1)*

Switching Elements

Quantity.....2 SPDT contacts
Operating principle..... Normally energized or de-energized (N/E)*
Electrical endurance10,000 cycles
Contact data acc. to IEC 60947-5-1:

Relay 1:

Utilization CategoryAC-13	AC-14	DC-12	DC-12	DC-12
Rated operational voltage 230 V	230 V	24 V	110 V	220 V
Rated operational current 5A	3A	1 A	0.2 A	0.1 A
Minimum contact rating1 mA at AC/DC \geq 10 V				

Relay 2:

Utilization CategoryDC-12	DC-12	DC-12	DC-12
Rated operational voltage 250 V	24 V	110V	220 V
Rated operational current2 A	1.2 A	0.4 A	0.25 A
Minimum contact rating1 mA at AC/DC \geq 10 V			

Environment / EMC

EMC IEC 61326
Operating temperature +14 F - +122 F (-10 C - +50 C)
Storage temperature-13 F - +158 F (-25 C - + 70 C)
Climatic class acc. to IEC 60721:
Stationary use (IEC 60721-3-3)3K5 (**)
Transport (IEC 60721-3-2)2K3 (**)
Long-term storage (IEC 60721-3-1) 1K4 (**)

** = Except condensation and formation of ice

Classification of mechanical conditions acc. to IEC 60721:

Stationary use (IEC 60721-3-3)	3M4
Transport (IEC 60721-3-2)	2M2
Long-term storage (IEC 60721-3-1)	1M3

Connection

Connection type.....	Molex plug, qty. 2
.....	15-pole, type 03-09-2159
.....	12-pole, type 43045-1215

General Data

Operating mode.....	Continuous
Mounting position	Display-oriented
Degree of protection, internal components	NEMA 1 (IP 30)
Enclosure material	Polycarbonate
Flammability class.....	UL94 V-0
Type of enclosure.....	Enclosure for panel mounting
Screw fixing	Qty. 4 #4-40 truss head black oxide finished
Tightening Torque.....	2.6 - 3.5 lb-in (0.3 - 0.4 N-m)
Firmware version.....	D301 V1.0x / D306 V1.0x
Weight.....	app. 1.2 lb (550 g)

7.2 Connector Plate

CP-LIM2010

Cable length	20" (508 mm)
Terminal strip	22 terminals
Connector	15 pin Molex and 12 pin Molex
Conductor size	AWG 22 - 12
Screw fixing.....	2-32 x1/2 slotted oval head machine screw SS
Tightening torque	8 lb-in (0.9 N-m)
Mounting orientation.....	Any
Weight	app. 7 oz (200 g)

7.3 Current Transformers

7.3.1 Technical Data: STW3

Rated voltage U_m	AC 720 V
Rated impulse voltage U_{isol}	4 kV

Measuring Circuit

Rated transformation ratio k_n	100 / 0.1 A
Rated burden.....	200 Ω
Maximum rated primary current.....	100 A
Minimum rated primary current	1 A
Nominal power	2 VA
Nominal frequency.....	50 - 400 Hz
Internal resistance	17 Ω
Accuracy class	1
Rated thermal current, continuous.....	120 A
Rated thermal current, 1 s	1000 A
Dynamic rated current, 30 s	2500 A

7.3.2 Technical Data: STW4

Rated voltage U_m AC 720 V
Rated impulse voltage U_{isol} 4 kV

Measuring Circuit

Rated transformation ratio k_n 200 / 0.1 A
Rated burden200 Ω
Maximum rated primary current 200 A
Minimum rated primary current 2 A
Nominal power2 VA
Nominal frequency50 - 400 Hz
Internal resistance 40 Ω
Accuracy class 1
Rated thermal current, continuous 240 A
Rated thermal current, 1 s2000 A
Dynamic rated current, 30 s5000 A

7.3.3 General Data: STW3 / STW4

Standard IEC 60044-1
Shock resistance acc. to IEC 60068-2-27 (built-in) 15 g / 11 ms
Bumping, IEC 60068-2-29 (during transport)40 g / 6 ms
Vibration resistance, IEC 60068-2-6 (built-in) 1 g / 10 - 150 Hz
Operating temperature +32 F - +185 F (0 C - +85 C)
Storage temperature -40 F - +185 F (-40 C - +85 C)
Climate category acc. to DIN IEC 60721-3-3 3K5
Operating mode Continous operation
Position Any position
Screw mounting M3
Flammability class UL 94V-0

Connection Type

ConnectionFaston plug, 6.3 x 0.8 mm
Single wires \geq AWG 18 (0.7 mm²) 3.2 ft (1 m)
Single wires, twisted \geq AWG 18 (0.7 mm²) 32 ft (10 m)
Screened cable \geq AWG 20 (0.6 mm²), 1 end grounded 132 ft (40 m)

7.4 Error Codes and Troubleshooting

Error Code	Description and Action
ERROR 0.10	<p>BAD CT CONNECTION Interruption in the connection of the load monitoring current transformer. Action: Check the connection of the current transformer to the connector plate. NOTE: The SWL-100A does not activate this alarm. Ensure proper connections if this device is used. The error will automatically clear itself when the issue is resolved.</p>
ERROR 0.20	<p>CT SHORT CIRCUIT A short circuit is present at the current transformer. Action: Check the current transformer for possible short circuit. The error will automatically clear itself when the issue is resolved.</p>
ERROR 0.30	<p>BAD GROUND CONNECTION Bad connection on LIM GND/GND2 ground loop Action: Ensure that both LIMGND and GND2 connections are not interrupted and properly tied to ground. The error will automatically clear itself when the issue is resolved.</p>
ERROR 0.40	<p>BAD SYSTEM CONNECTION Indicates that the system voltage does not fall within the threshold required by the LIM2010 and that one of the following has occurred: - < 85 V, > 265 V - Nominal frequency outside 50/60 Hz range Action: Ensure that the system voltage and frequency of the system fall within the limits of the LIM2010. The error will automatically clear itself when the issue is resolved.</p>
ERROR 2.10	<p>NO MASTER No BMS (RS-485 communication) master exists. Even if RS-485 communication is not utilized, the LIM2010 must be assigned an address of 1. Action: If the LIM2010 is connected to a BMS network, ensure that one device on the network is set to address 1. Otherwise, set the LIM2010 to address 1. The error will automatically clear itself when the issue is resolved.</p>
ERROR 2.20	<p>RS-485 ERROR BMS bus error. Action: Ensure that there are no conflicting address settings on the RS-485 bus. Check RS-485 wiring. The error will automatically clear itself when the issue is resolved.</p>

Error Code	Description and Action
Error 8.80	<p>BATTERY LOW</p> <p>The battery backup for the built-in clock is discharged. This error may occur when first installing the device.</p> <p>Action: Enter the main menu. Check the time and date settings, and reset them if required. The battery will then recharge during normal operation.</p> <p>The error will automatically clear itself when the issue is resolved.</p>
All other errors	Action: Contact the manufacturer.

7.5 Dimensions: STW3 / STW4

Dimensions in inches (mm)

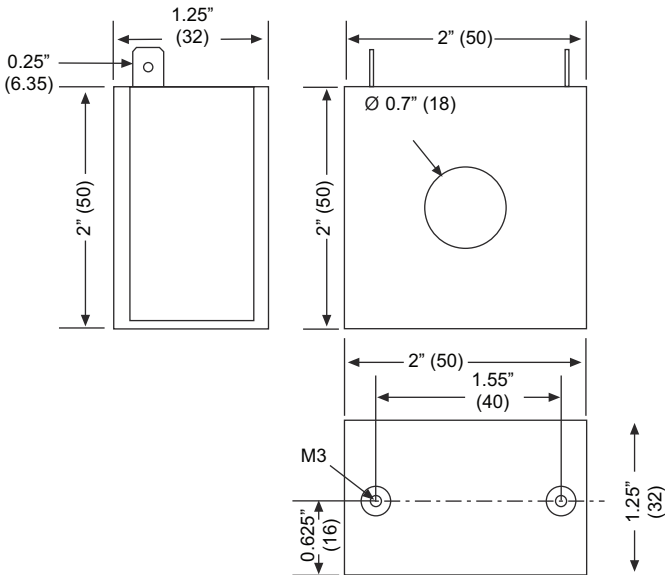

7.6 Ordering Information

Type	Description	Approval	Ordering No.
LIM2010	Line Isolation Monitor	UL Listed	B 9207 5021
CP-LIM2010	LIM Connector Plate	UL Recognized	B 5111 00001
Remote Indicators			
MK2000-G1	Mute Single gang plate	UL Listed	B 5213 00002
MK2000-G2	Mute Two-gang plate	UL Listed	B 5213 00007
MK2000P-G1	Mute + Test Single gang plate	UL Listed	B 5213 00188
MK2000C-G1	Mute + Overload Single gang plate	UL Listed	B 5213 00020
MK2000CP-G1	Mute + Test + Overload Single gang plate	UL Listed	B 5213 00021
MK2000CBM	Mute + Test + Overload Digital Metering Two-gang plate	UL Listed	B 5313 00022
Load Monitoring Current Transformers			
STW3	Up to 100 A load current	UL Recognized	B 9802 1000
STW4	Up to 200 A load current	UL Recognized	B 9802 1001
LIM Testers			
LT3000 Kit	Tester Only	-	B 5213 00004
LT3000 Set	Tester + Carrying Case + Adapter for 2300HG receptacle	-	B 5213 00295



Bender Inc.

USA:

700 Fox Chase

Coatesville, PA 19320

Toll Free: 800-356-4266

Phone: 610-383-9200

Fax: 610-383-7100

E-mail: medical@bender.org

Canada:

5810 Ambler Drive, Unit 1

Mississauga, ON L4W 4J5

Toll Free: 800-243-2438

Phone: 905-602-9990

Fax: 905-602-9960

E-mail: info@bender-ca.com



Web: www.bender.org

BENDER Group
