

ACROPRINT®
Time for Business.™

ATR360



***Top Loading Time Recorder
With Fingerprint & Proximity Badge
User Verification***

≡ User Manual ≡

Lithium Battery Caution:

The circuit board on this terminal is populated with a lithium battery to protect data or programs stored in the Random Access Memory (RAM). Do not, under any circumstances, attempt to replace the lithium battery in the terminal. Failure to comply may void your warranty. Battery replacement should be done by qualified personnel wearing the proper eye protection.

CAUTION: Danger of explosion if the battery is incorrectly replaced. Replace only with the same or equivalent type recommended by the manufacturer. Discard used batteries according to the manufacturer's instruction.

This product utilizes a battery that contains Perchlorate Material. Perchlorate Material – special handling may apply, See www.dtsc.ca.gov/hazardouswaste/perchlorate

Table of Contents

Before You Start!	1
What's In the Box.....	1
Time Recorder Mode Settings.....	2
Clock Overview	3
Top View	3
Front View.....	3
Rear View	4
Initial Setup	5
Using the Time Clock	12
Features and Specifications	14
Clock Features.....	14
Clock Specifications.....	14
Fingerprint Recognition	14
Miscellaneous	15
Ribbon Life	15
Operational Battery Pack	15
Troubleshooting	18
Frequently Asked Questions	20
Maintenance	22
Replacing the Ribbon Cassette.....	22
Replacing the Circuit Board Batteries.....	23
Installing the Operational Battery Pack	24
Cleaning the ATR360	25
Cleaning the Fingerprint Sensor.....	25
Appendix	26
Connecting External Signal Devices (Bells & Horns).....	26
Wall Mounting Instructions	27
Fingerprint Privacy	27
Supplies, Parts & Accessories	28
Acroprint® Limited Warranty	29
Product Registration Card	30

Before You Start!

What's In the Box

- ATR360 Time Recorder
 - (2) Clock Cover Keys
 - 18vDC Switching Power Supply
 - User Manual
 - (25) Sample ATR241 Weekly Time Cards
 - (5) Sample Proximity Badges
 - Clock Wall Mounting Template
(Also available for download at <http://support.acroprint.com>)
 - (2) Mounting Screws
 - (2) Plastic Wall Anchors
- 1) Unpack clock. Inspect clock for any damages that may have occurred during shipment. Check box contents for any missing items. If any damages are found or if any parts are missing please contact Acroprint Customer Service at (800) 334-7190.
 - 2) Open clock cover and remove the plastic battery insulators. Pull the insulators straight up with a slow and steady motion to avoid tearing them. If an insulator is torn it will prevent the battery from making contact. If this happens contact Acroprint Customer Service at (800) 334-7190.
 - 3) Connect the ATR360 power adapter and plug it into a wall outlet to turn the clock on.

Do not attempt to service the ATR360 yourself. Disassembling the clock will void the warranty. Always follow the instructions in the user guide.

- Do not place the clock in direct sunlight. Bright light may significantly affect fingerprint reads or cause fingerprint verification to fail.
- The clock is designed for indoor use in a temperature range of 32-104° F (0-40° C). The clock is not waterproof or shockproof. Keep the clock away from heat sources such as radiators. Avoid dusty environments or exposure to chemicals.

- The clock may be placed upright on a solid surface or mounted to a wall with mounting screws. Use the enclosed template & screws for wall mounting. Avoid locations where the device will be susceptible to vibrations and shock, such as a slamming door.
- The terminal warranty does not cover defects or damages arising from improper installation, improper storage, abuse, or unauthorized service.

Time Recorder Mode Settings

Mode	Setting	Values	Default Value
01	Year	2000 – 2099	Year of Mfg
02	Date	1-12 Mo, 1-31 Date	01, 01
03	Time	1-23 Hr, 0-59 Min	12 : 00
04	End of Day Change Time	1-23 Hr, 0-59 Min	00 : 00
05	Set Card Format (Set "00" for ATR241 cards)	00: first row blank 01: prints on 1 st row	00
06	Pay Period Type End Day of Wkly P.Period Must set 07 for Wkly Card	00: Mthly, 01: Wkly 01=Mon...07=Sun	01 07
07	Clock Display Format	12 or 24 Hr	12
08	Adjust Printing Position Max: 6mm Vert/Horiz adj. Increase #'s to move up/right	00-15: Vertical Axis 00-30: Horiz. Axis	08,08 ↑ ↑ vert,horiz
09	DST Start Month / Date DST Start Time	1-12 Mo, 1-31 Date 00-23 Hr	00, 01 02
	DST End Month / Date DST End Time	1-12 Mo, 1-31 Date 00-23 Hr	00, 01 02
10	Print Format (Independent of display format)	00: 24 Hr 01: Decimal Hrs 02: 12 Hr (pm)	02
11	Time Card Recognition Note: Turn "On" for Mthly cards	00: On, 01: Off	01

Note: pressing "All-Reset" on the control panel will reset all Time Recorder settings to their factory defaults.

Clock Overview

Top View

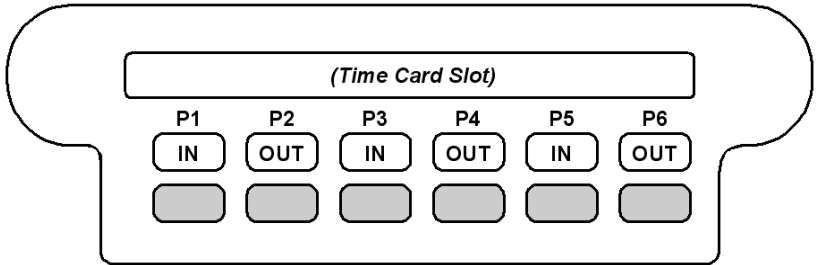

Front View

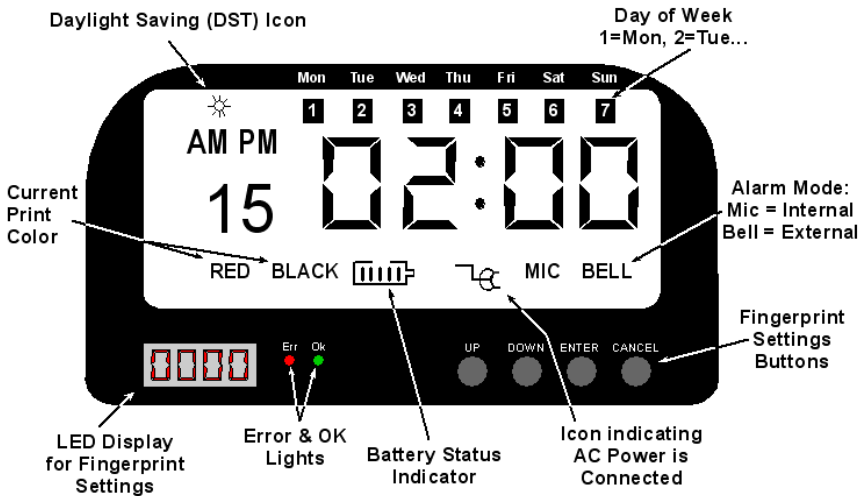

- Battery Status Indicator: A fully charged Battery will have (5) bars.
- DST Icon: displays when exiting programming mode when DST is turned on.
- Each blink of the colon is one sec.

Rear View

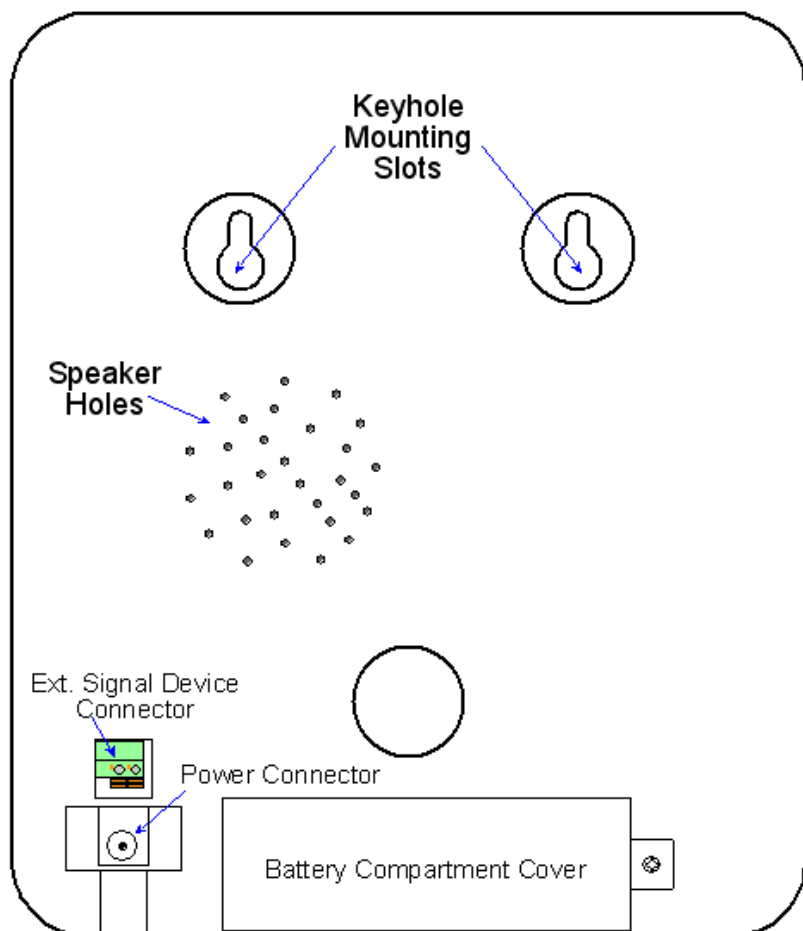

Initial Setup

Setting Year

1. Remove top cover
 - a. Locate buttons at the top of the clock labeled P4, P5 and P6
 - i. P4 changes values down
 - ii. P5 changes values up
 - iii. P6 is used to save and select modes
2. Locate the program switch to the left of the finger print reader. Move the switch to the down position, you are now in setup mode
3. The mode indicator “01” will be flashing, press P6 to select
4. Press P4 or P5 to select the current year
5. Press P6 to Save

Setting Month/Date

6. The mode indicator “02” will be flashing, press P6 to select
7. Press P4 or P5 to select the current month
8. Press P6 to save
9. Press P4 or P5 to select the current date
10. Press P6 to save

Setting Time

11. The mode indicator “3” will be flashing, press P6 to select
12. Press P4 or P5 to select the current hour
13. Press P6 to save
14. Press P4 or P5 to select the current minute
15. Press P6 to save

Setting Day Advance Time

16. The mode indicator “04” will be flashing, press P6 to select
17. Complete steps 11-15

Setting Pay Period

18. The mode indicator “05” will be flashing, press P5 to switch to mode “06”
19. The mode indicator “06” will be flashing, press P6 to select
20. Select the pay period type by pressing P4 or P5
 - a. If the pay period is monthly select 00
 - b. If the pay period is weekly select 01
21. Press P6 to save
22. To select the end of the weekly pay period you must select 07
23. Press P6 to save

Setting Clock Display Format

24. The mode indicator “07” will be flashing, Press P6 to select
25. Press P4 or P5 to select the clock display format
 - a. You can choose between the 12 hour or 24 hour (military time) format
26. Press P6 to save

Setting Start and End of DST

27. The mode indicator “08” will be flashing, press P5 to switch to mode “09”
28. The mode indicator “09” will be flashing, press P6 to select
29. Press P4 or P5 to select the correct month (US-March)
30. Press P6 to save
31. Press P4 or P5 to select the correct date
32. Press P6 to save

33. Press P4 or P5 to select the correct start time (US-2am)
34. Press P6 to save
35. Complete steps 29-34 to complete the set up for the end of DST

Setting Print Format

36. The mode indicator “10” will be flashing, press P6 to select
37. Press P4 or P5 to select the correct print format
 - a. 00 – 24 hour (Military Time)
 - b. 01 – Decimal Hours
 - c. 02 – 12 hours (pm)
38. Press P6 to save

Setting Time Card Recognition

39. The mode indicator “11” will be Flashing, press P6 to select
40. Press P4 or P5 to select the correct the correct time card format
 - a. 00 – Monthly, Semi-Monthly
 - b. 01 – Weekly, Bi-Weekly
41. Press P6 to save

Initial setup is complete. Locate the program switch and move it to the up position. Replace top cover.

Correct Finger Positioning on the Sensor

Place finger flat on the sensor surface

Place finger in the center of the sensor surface

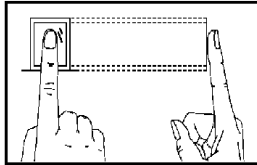

Incorrect Finger Positioning:

Vertical

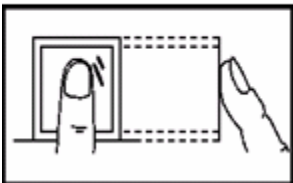

Offset

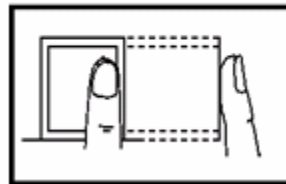

Inclined

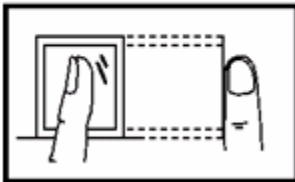

Lower

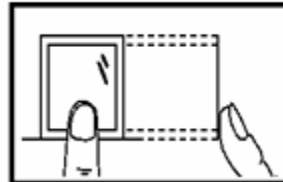

Tips for Improving the Success of Fingerprint Reads

Finger Print Setup

1. Remove top cover
2. Locate the finger print switch located to the left of the finger print reader
3. Move the switch to the up position to turn on the finger print reader.
4. Press the "FP Setup" button until ADD.U appears in the front LED display
 - a. If no activity is detected within 30 seconds the setup program will be terminated and the "FP Setup" up button must be pressed again

Add User

5. Press enter
 - a. Users must be assigned a number user number. You may add up to 150 users and 5 administrators
6. To assign the user a number use the up and down buttons to change each digit. Start with first digit. (For the number 001 you will start with 0). Press enter to go to the next digit.
 - a. User numbers will appear Uxxx and can be assigned numbers U001-U150
 - b. Administrator numbers will appear Axxx and can be assigned numbers A301-A305
7. When you have completed assigning the user, while the last digit is flashing press and hold the enter button for 3 seconds
8. The LED display will change to F.P.x.x
9. To register a finger print the last digit should be flashing
10. Place the finger on the finger print reader. 3 samples must be giving. If the finger print is accepted the LED Display will change (F.P.1.1, F.P.1.2, F.P.1.3) after all 3 samples are giving and accepted the message PASS will appear
11. Now select a second finger for a back up print
 - a. This is for situations where the primary finger cannot be used because of injuries to the finger or the reader is unable to read the finger print
12. The LED display will read F.P.2.1
13. Complete step 10 to register the back up print
14. A third back up print may be registered or press cancel
15. Complete steps 5-13 to add another user or press cancel, down, enter to exit

Badge Setup

1. Remove top cover
2. Locate the finger print switch located to the left of the finger print reader
3. Move the switch to the up position to turn on the finger print reader.
4. Press the “FP Setup” button until ADD.U appears in the front LED display
 - a. If no activity is detected within 30 seconds the setup program will be terminated and the “FP Setup” up button must be pressed again
5. Press enter
 - a. Users must be assigned a number user number. You may add up to 150 users and 5 administrators
6. To assign the user a number use the up and down buttons to change each digit. Start with first digit. (For the number 001 you will start with 0). Press enter to go to the next digit.
 - a. User numbers will appear Uxxx and can be assigned numbers U001-U150
 - b. Administrator numbers will appear Axxx and can be assigned numbers A301-A305
7. To skip finger print recognition press cancel
 - a. The third digit should be flashing
8. Press the down button the LED display will read “rFid”
9. Press enter the LED display will read “CARD”
10. Scan the card. If the card is successfully scanned the LED display will indicate “PASS”
11. Complete steps 5-10 to add another user badge or press cancel, down, enter to exit

Set Ink Color Change Time

1. Remove top cover
2. Locate the program switch to the left of the finger print reader. Move the switch to the down position, you are now in setup mode
3. Press P1.
 - a. P1,P4,P5,P6 will now be flashing
4. If this is the initial setup you must begin with 01

5. Press P6 to save
6. Press P4 or P5 to select the correct hour
7. Press P6 to save
8. Press P4 or P5 to select the correct minute
9. Press P6 to save
10. Press P4 or P5 to select the correct color
 - a. 01 – Black
 - b. 02 – Red
11. Press P6 to save
12. Deselect days by pressing P4 or P5 to highlight the day. Press P1 to deselect the day. After P1 is pressed the day will disappear
 - a. 7 = Sunday, 1 = Monday....
 - b. To reselect the day's press P4 or P5 until the day is flashing then press P1
13. Press P6 to save
14. Complete steps 5-13 to complete the remaining 11 slots or to exit setup move the program switch to the up position

Set Column Change Time Setup

1. Remove top cover
2. Locate the program switch to the left of the finger print reader. Move the switch to the down position, you are now in setup mode
3. Press P3
 - a. P3, P4, P5, P6 will now be flashing
4. If this is the initial setup you must begin with 01
5. Press P6 to save
6. Press P4 or P5 to select the correct hour for the first time slot
7. Press P6 to save
8. Press P4 or P5 to select the correct column
 - a. Choose a column 1-6
9. Press P6 to save
10. Complete steps 4-9 until all slots are completed or to exit move the program switch to the up position

Using the Time Clock

Using the Time Card to Clock In

1. When clocking in P1, P3 or P4 must be selected
2. Insert the time card with the current week facing you and the card in the upright position
3. The time card will automatically feed into the time clock and print the correct time
4. Remove the time card

Using the Time Card to Clock Out

1. When clocking out P2, P4 or P5 must be selected
2. Insert the time card with the current week facing you and the card in the upright position
3. The time card will automatically feed into the time clock and print the correct time.
4. Remove the time card

Using a Finger Print to Clock In

1. When clocking in P1, P3 or P4 must be selected
2. Insert the time card with the current week facing you and the card in the upright position
3. Using a registered finger place the finger on the finger print reader. If the finger print is accepted the time card will automatically feed into the time clock and print the correct time.
4. Remove the time card

Using a Finger Print to Clock Out

1. When clocking out P2, P4 or P5 must be selected
2. Insert the time card with the current week facing you and the card in the upright position
3. Using a registered finger place the finger on the finger print reader. If the finger print is accepted the time card will automatically feed into the time clock and print the correct time
4. Remove the time card

Using a Badge to Clock In

1. When clocking in P1, P3 or P4 must be selected
2. Insert the time card with the current week facing you and the card in the upright position
3. Scan the badge by placing it in front of the badge scanner, if the badge is accepted the time card will automatically feed into the time clock and print the correct time
4. Remove the time card

Using a Badge to Clock Out

1. When clocking out P2, P4 or P5 must be selected
2. Insert the time card with the current week facing you and the card in the upright position
3. Scan the badge by placing it in front of the badge scanner, if the badge is accepted the time card will automatically feed into the time clock and print the correct time
4. Remove the time card

Features and Specifications

Clock Features

User Authentication Method	Fingerprint or Proximity Badge
Display Language	English
Operation Mode	Stand-alone (No PC Interface)
Proximity Card Reader	EM
Operational Battery Backup	Optional
Auto Card Feeder	Yes
Printing Method	9-Pin Dot Matrix
Eliminates Buddy Punching	Yes
Two Color Printing	Yes
Perpetual Calendar	Yes
Auto Fix Positioning	Yes
Power Failure Printing	Yes
Power Failure Memory Retention	Yes
Display Format	12 or 24 hour
Print Format	12 hr, 24 hr, decimal time
External Alarm	Connection Available
Auto Column Changing	Yes
Compatible with Wkly Time Card	Yes (Card Recognition <i>Off</i>)
Card Recognition (front/back)	Yes

Clock Specifications

Fingerprint Recognition

Effective FP Detection Area	16 x 14 mm
Average Recognition Speed	1.2 sec
FRR	≤0.01%
FAR	≤0.0001%
Fingerprint Verification	1:N
Fingerprint Placement Angle	360°
Fingerprint Template Capacity	150

Miscellaneous

Input Voltage	DC 18v
Input Current	1.5A
Anti-static Strength	< 15KV
Operational Relative Humidity	10 – 60%
Operational Temperature	0 – 40° C (32 – 104° F)
Storage Relative Humidity	10 – 80%
Storage Temperature	-10 – 60° C (14 – 140° F)
Dimensions (Clock)	197 (w) x 239 (h) x 133 (d) mm
Dimensions (Box)	266 (w) x 283 (h) x 208 (d) mm
Weight (Clock Only)	4.3 Lbs.
Weight (Boxed)	4.5 Lbs.
Time Card Dimension	190 – 192mm x 85-85.5mm
Time Card Weight	300g
Circuit Board Batteries (2)	CR2032 (2 yr life)

Ribbon Life

The ATR242 ribbon (39-0135-000) will typically last 3 months with 50 employees punching 6 times per day (~18,000 punches). Actual ribbon life will vary based on the number of punches, humidity, temperature and exposure to air.

Operational Battery Pack

The optional Operational Battery Pack (58-0114-000) is a 12 cell NiMH (Nickel Metal Hydride) battery pack that recharges when the ATR360 is plugged in. In the event of a power failure the clock will instantly switch to battery power without any interruption in service. The operational battery pack allows for full operation of the clock with punching using the fingerprint reader or Prox badge. The clock will also continue to print on time cards. The LCD backlight is not activated when the clock is running on battery power in order to save power, however, the LCD display is plainly visible in a lighted room.

Battery Pack Specs:

Voltage: DC 14.4v

Capacity: 1800mA

Standby mode: 30-36hr reserve power

Fully charged: 5 days use (300 punches/day)

Note: Actual battery life depends on many factors such as battery age, temperature, discharge history, etc., and can vary greatly depending on these factors.

The ATR360 should be plugged in for 12 hours to fully charge the battery pack.

For more information see “Installing the Operational Battery Pack” in the Appendix.

Warning:

Batteries may leak, overheat, catch fire or explode if proper safety & handling procedures are not followed:

- DO NOT get batteries wet
- DO NOT place batteries near heat sources
- DO NOT use any power supply other than the original one supplied with the time recorder.
- DO NOT inverse polarity connection
- NEVER throw batteries into fire. Properly dispose of batteries according to local rules and regulations.
- DO NOT allow anything to short circuit the batteries
- Dropping a battery may damage the battery.
- Replace the battery if you suspect any damage.

Internal View

(Internal Control Panel)

Note: turning the Fingerprint Reader off will also disable the Proximity Badge Reader.

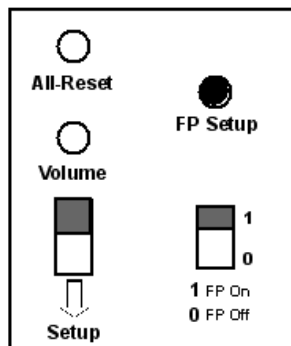

Problem	Correction
How to select finger?	Use the index or middle finger to enroll; try the left hand fingers if the right hand fingerprints are worn, damaged or missing. If the user's fingers are small, select the thumb.
Poor Fingerprint Definition	Some people have fingerprint definition that is too poor to verify. These employees should use Proximity badge verification.
Dirty or Dry Finger	Wash hands with moisturizing soap or use hand lotion to hydrate skin.
Damaged Fingerprint	Use alternate finger with backup fingerprint template.
Bad Finger Positioning	Place finger in the middle of the sensor; keep finger flat on the sensor and apply firm pressure; DO NOT touch the sensor in an angled or tilted position, DO NOT slide finger.
Fingerprint pattern change	For a user with a worn or injured finger, the identification can be affected. Use an alternate finger or select Proximity badge verification.
Clock has trouble reading most fingerprints	Clean the fingerprint sensor (see cleaning the fingerprint sensor. Using a fingerprint overlay on the sensor will often significantly improve fingerprint reads (call Acroprint for availability).
Clock has trouble reading fingerprints on sunny days	Move clock out of direct or bright sunlight.

Troubleshooting

Symptom	Possible Problem	Solution
Clock does not power on	Power Outage	Check circuit breaker. Wait for power to be restored
	The power source was not properly connected	Check the connections of the power supply and/or backup battery
The time is incorrect	The time was not set correctly	Set correct time
	Prolonged power outage	Set time after power is restored
The date is incorrect	The date was not set correctly	Set correct date
Clock beeps and rejects time card	Wrong side of card is inserted (monthly card)	Flip card over and re-insert
	Incompatible time card	Use card approved for the ATR360
Print too light	Ribbon cassette not properly seated	Remove and re-insert ribbon cassette correctly
	The print ribbon is dried out	Replace ribbon cassette
Clock will not print	RTC not synchronized with display time.	Set RTC
Punches print in wrong column	Wrong column selected (manually selected) or column change time set incorrectly	Select the correct column (P1 – P6) or set the correct column change time
Punches print on wrong row	The End of Day set incorrectly	Set End of Day correctly
	Time Card Format set incorrectly	Set Time Card Format again
	Pay period type is set incorrectly.	Set Pay Period type correctly

Symptom	Possible Problem	Solution
The clock keeps losing time	The coin cell battery on the motherboard needs to be replaced	Replace the coin cell on the motherboard
Display Off, Clock has Power	Defective Motherboard	Contact Local Dealer or Acroprint for repair.
	Defective LCD Display	
Display is in AM/PM hours but clock prints in 24 Hr format	The clock display format and print format are independent. You must make sure each is set correctly.	Set the display format correctly Set the print format correctly
Clock is printing in wrong color	Ink Color Change Time set incorrectly	Set the Ink Color Change Time correctly
Clock print location is a little off	Clock printing position needs to be adjusted	Adjust the clock print position
Print registration is faint or not visible at all	Ribbon cassette not firmly seated.	Press down firmly on ribbon cassette until it clicks into place.
	Ribbon is stuck.	Turn ribbon advance knob clockwise. If ribbon will not advance remove cassette and try advancing again. If ribbon won't advance replace ribbon.

Frequently Asked Questions

1. Q: Why can't the clock verify my fingerprint?
A: Possible Causes: The following conditions could result in a failed read.

 - a. Finger is dry
 - b. Fingerprint is damaged
 - c. Finger was not properly positioned when enrolled
 - d. Employee hasn't been enrolled
 - e. Fingerprint sensor is dirty
 - f. Fingerprint sensor is defective

Correction: Moisturize finger. Enroll a different fingerprint or re-enroll finger. Clean fingerprint sensor.
2. Q: The display does not work or parts of it do not work.
A: Possible Causes:

 - a) Motherboard is defective
 - b) The LCD display is defective.

Correction: Contact your local dealer or Acroprint for repair.
3. Q: How do I change an employee from an Administrator to a user?
A: Delete the employee and re-enroll them as a user.
4. Q: I checked all settings on my clock and it still won't print on my time card.
A: Make sure the RTC and clock display are synchronized.
1. Q: Why is the light for the fingerprint reader not working?
A: Make sure the fingerprint switch is set to "FP ON".
If this doesn't correct the problem contact your local dealer or Acroprint for repair.
2. Q: Can I turn the fingerprint reader off and just use prox badges?
A: No. Sliding the FP switch to "off" also disables the Prox reader.
3. Q: If I turn the fingerprint reader off can I still punch my time card?
A: Just insert your card. It will automatically be "punched" since user verification is turned off.

4. Q: I pressed FP setup but why does nothing happen?
A: Make sure the FP Switch is "On". You cannot access the FP settings if the FP Switch is turned "Off".
5. Q: Why do I get an "err" message when registering my prox badge?
A: The badge has already been registered to another User ID or the badge could be defective.
6. Q: Why do I get an "err" message when swiping my prox badge?
A: Check to make sure the badge is registered.
7. Q: Can my clock calculate the pay period total?
A: No. The ATR360 does not offer time total calculation.
8. Q: Why does the clock keep rejecting the time card?
A: Check to see if the correct side of the Time Card is inserted. If Time Card Recognition is turned on your Monthly Time Card must be inserted with the current date on the front side. If you are using a Weekly Time Card make sure Time Card Recognition is turned off.
9. Q: Why didn't the time recorder setting I changed not work?
A: Make sure you press [P6] after you enter your setting.
10. Q: Why is my clock printing on the wrong row?
A: - Make sure the date is set correctly.
- Make sure the "End of Day" time is set correctly.
- For Weekly pay periods make sure the "End Day of Pay Period" is set correctly.
- Make sure the Pay Period type is set correctly.
11. Q: I can't get my clock to print for any employees. It just keeps giving an "err" message.
A: Make sure the display time is synchronized to the RTC time.

For more info on troubleshooting or general "how to" info go to:

<http://support.acroprint.com>

Maintenance

Replacing the Ribbon Cassette

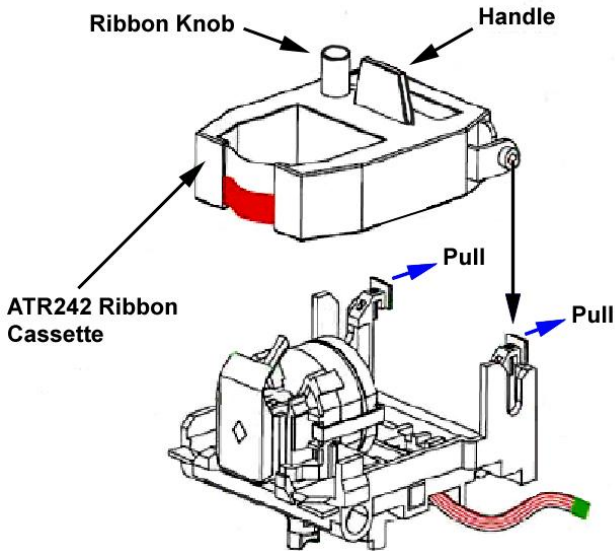

1. Open clock cover. Press “P3” to move the print head to the center of the clock so that the ribbon cassette can be more easily accessed.
2. Pull the ribbon holder tabs towards you to unlock the ribbon cassette and use the handle on top of the ribbon to pull the cassette out.
3. Insert replacement ribbon. Make sure to feed the ribbon over the black ribbon guide and slide the ribbon down between the guide and the silver print shield. Push the ribbon down until it clicks into place. Turn the ribbon winding knob clockwise to remove any slack in the ribbon.

Replacing the Circuit Board Batteries

The ATR360 is equipped with (2) CR2032 3v Lithium Coin Cell batteries: one battery is on the Main board and the other is on the Display board. The batteries should last approximately 1.5 to 2 years under normal operating conditions. Do not attempt to replace these batteries as it will void your warranty. If your clock is already out of warranty you can attempt to replace the batteries yourself but note that you could damage the boards if you short out any components on the circuit board. Avoid using metal objects to remove the batteries.

Note: All Time Recorder settings will be reset to factory defaults as soon as the Main board battery is removed.

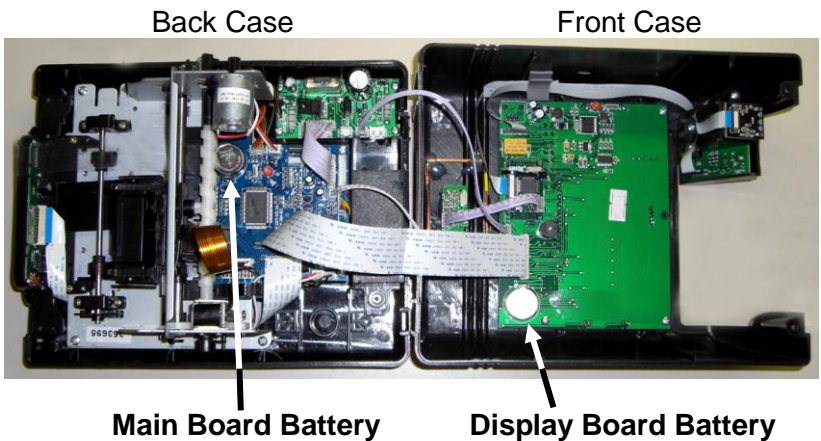

1. Unplug clock.
2. Remove the front cover and the two screws that connect the front and back case. Remove the front case and lay it flat being careful not to pull any wires or cables loose.
3. To remove batteries press the metal retaining clip away from the battery. The battery should pop up. It may be necessary to use a small probe to pop the battery out.
4. Replace the batteries and re-assemble clock.

Installing the Operational Battery Pack

First unplug the clock. The door to the battery pack compartment is located on the bottom edge of the back of the clock. Remove the screw that secures the door. The door may be tightly fitted. Insert a thin knife blade under the bottom of the door at the screw end and rotate the blade to open the door.

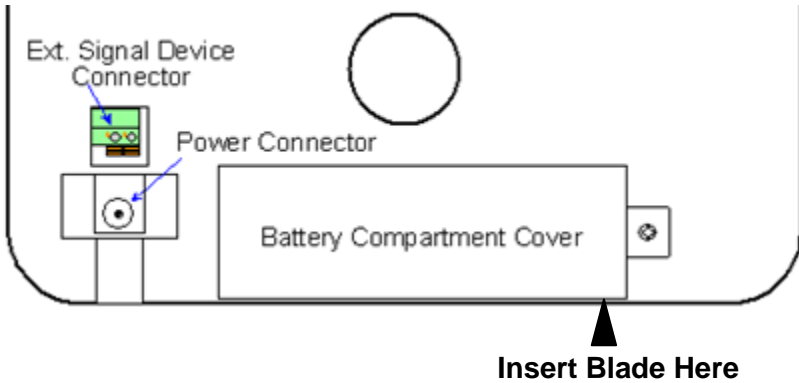

Connect the battery cable to the connector on the left side of the compartment. Note that the two ridges on the side of the battery connector should be facing down to line up with the slots in the clock's power connector. Turn the battery so that the cable connection is on the bottom. Insert the battery pack into the clock with the wires inserted into the opening in the side of the compartment. This is important since the battery door can't be attached if the battery is sitting on top of the wires. You may need to use a pencil or screwdriver to push the wires into the opening. Attach the door by inserting the door tabs into the left side of the compartment and firmly rotating the door into place. If the door won't close check to make sure the wires aren't under the battery. Plug in the power supply once the battery door is secure. The ATR360 should be plugged in for 12 hours to fully charge the battery pack.

Cleaning the ATR360

Do not use cleaning products that contain alcohol or other strong chemicals as they could discolor or crack the terminal housing. Use a soft damp cloth to remove dirt. Wipe dry.

Cleaning the Fingerprint Sensor

Caution: Do not use any cleaners on the sensor or it could be damaged.

If there is a fingerprint overlay on the fingerprint sensor you can do a quick clean by lightly pressing a small strip of adhesive tape to the overlay and then slowly peel it off to remove dust & dirt particles. You can also remove it and clean it with soapy water then rinse and dry and re-attach to the sensor.

Clean the fingerprint sensor glass as follows:

1. Use a can of compressed air to blow off any loose dust or dirt particles on the sensor.
2. Use a soft, lint free non-abrasive dry cloth to wipe the sensor surface. Be careful not to scratch the surface of the sensor. If there are lint particles on the sensor surface, use clear adhesive tape to remove particles. Place the clean overlay over the sensor glass (if applicable).

Appendix

Connecting External Signal Devices (Bells & Horns)

The connections for an external signal device (bells, horns, buzzers, chimes, etc) are made via a 2-wire Green terminal block on the back of the clock above the power jack. Connections are made by pressing the orange wire release tabs below each wire hole, fully inserting the wire and releasing the clip. Gently pull on the wires to make sure they are firmly secured in the terminal block.

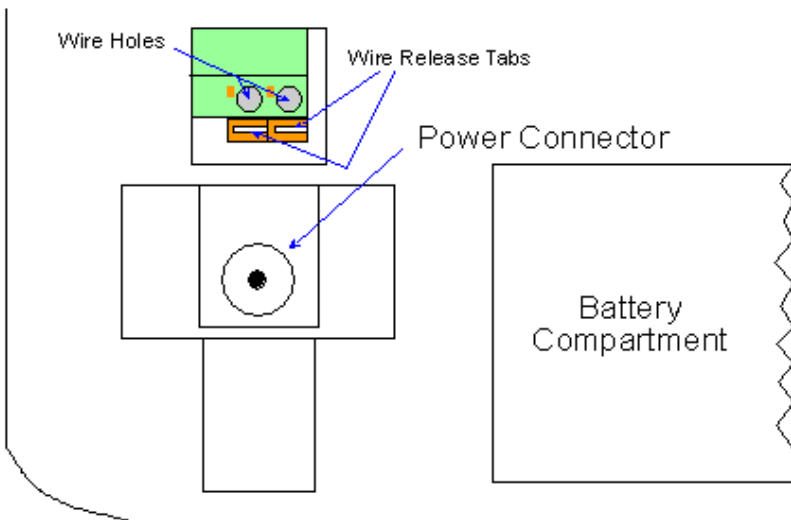

Clock Back Housing, Lower Left Corner

In order to use a bell or horn a relay is required. Please call Acroprint or your Dealer to order the relay (PN 01-0230-000).

When a signal is activated by the clock the internal contacts of the relay close and complete the circuit. These internal contacts are "dry" and supply no voltage. Voltage applied to these contacts must not exceed 30 volts. The relay then activates the 120v external signal device such as:

65-0103-000 "Grille Horn"

65-0104-000 "4-1/4" Bell"

65-0105-000 "8" Bell"

For more information about connecting an external signal device using a relay go to

<http://support.acroprint.com>

Under "Time Clocks & Document Stamps" click on "ATR360 Time Clock" in the drop down menu and download 06-0346-000 "Connecting an External Signal Device".

Wall Mounting Instructions

The ATR360 can be placed on a table or desk and it can also be mounted to a wall. A mounting template is included with the documents for the ATR360. If you misplace the template you can download it at:

<http://support.acroprint.com>

Under "Time Clocks & Document Stamps" click on "ATR360 Fingerprint Clock" in the drop down menu.

Follow the instructions on the template to mount the clock.

Fingerprint Privacy

1. The ATR360 merely captures points of the fingerprint but not the actual fingerprint image.
2. The fingerprint points cannot be used to create a fingerprint image.
3. Acroprint will not be liable for any direct or indirect damages resulting from the use or inability to use the clock.
4. If you have a question about privacy concerning the use of the clock you should have your employer contact Acroprint.

Supplies, Parts & Accessories

Part#	Description
01-0230-000	24 Volt Switching Relay Kit
01-0270-000	ATR360 Biometric/Proximity Time Recorder
01-0270-001	ATR240 Time Recorder
06-0400-000	ATR360 User Manual (available on web)
06-0400-001	ATR240 User Manual (available on web)
06-0401-000	Mounting Template (available on web)
09-7000-000	ATR241 Weekly Time Card (pack of 250)
09-7001-000	ATR241 Monthly Time Card (pack of 250)
14-0126-000	Proximity Badges (pack of 15)
39-0135-000	ATR242 Red/Black Ribbon Cassette
45-0182-000	ATR240/360 Case Keys (set of 2)
45-0183-000	125 kHz RFID Key Fob (Pack of 15)
56-0135-000	18v DC Power Supply (w/removable plug)
58-0114-000	ATR240/360 Operational Battery Pack
58-0111-000	CR2032 3v Lithium Coin Cell Battery
64-0103-000	Grille Horn, 120vAC 50/60Hz
64-0104-000	4-1/4" Bell, 120vAC 50/60Hz
64-0105-000	8" Bell, 120vAC 50/60Hz
75-0185-000	US Power Plug (for 56-0135-000)
75-0185-001	Euro Power Plug (for 56-0135-000)
75-0185-002	UK Power Plug (for 56-0135-000)

An updated list of accessories with pricing can be found on the web at: **www.acroprint.com**

Acroprint® Limited Warranty

Should you have any questions concerning your warranty information or supplies, please contact the dealer or store where you purchased the equipment.

This product is guaranteed to the original purchaser for a period of one (1) year from original purchase date against defective materials and workmanship when used under normal operating conditions. The repair or replacement of any defective component or part and any necessary adjustments will be made free of charge provided that the machine is shipped prepaid to the factory service center shown below, securely packaged and shipped in the original shipping container. This warranty applies to Acroprint products purchased and retained in the U.S.A. The guarantee is not applicable if the device has been subject to misuse, abuse, negligence, accidents, power surges and lightning. The guarantee is not applicable if the serial number has been altered, defaced or removed or if the device has been tampered with or taken apart by other than authorized service personnel.

Please return the warranty card on the following page to Acroprint to register your product. Or, if you would like to register online go to **www.acroprint.com**. For your reference, fill out the information below and keep it in a safe place.

Model Number _____

Serial Number _____

Date Purchased _____

Purchased From _____

Location _____

Telephone Number _____

Acroprint Time Recorder
5640 Departure Drive
Raleigh, NC 27616-1841

Product Registration Card

Cut Here

Model No. _____ Serial No. _____

First Name _____ Last Name _____

Title _____

Company Name _____

Address _____

City _____ State _____ Zip _____

Daytime Phone with Area Code _____

Purchased From _____ Purchase Date _____

Email Address _____

So that we may serve you better, please indicate your primary business activity.

- | | |
|---|---|
| <input type="checkbox"/> (01) Manufacturing | <input type="checkbox"/> (04) Government |
| <input type="checkbox"/> (02) Wholesale | <input type="checkbox"/> (05) University / School |
| <input type="checkbox"/> (03) Retail | <input type="checkbox"/> (06) Other _____ |

Number of Employees Using Product

- | | |
|---------------------------------------|--|
| <input type="checkbox"/> (11) 1 - 10 | <input type="checkbox"/> (14) 50 - 75 |
| <input type="checkbox"/> (12) 11 - 25 | <input type="checkbox"/> (15) 76 - 100 |
| <input type="checkbox"/> (13) 26 - 49 | <input type="checkbox"/> (16) 100+ |

Annual Sales in Dollars

- | | |
|---|---|
| <input type="checkbox"/> (21) Under \$100,000 | <input type="checkbox"/> (24) \$500,000 - \$1,000,000 |
| <input type="checkbox"/> (22) \$100,000 - \$250,000 | <input type="checkbox"/> (25) \$1 million - \$5 million |
| <input type="checkbox"/> (23) \$250,000 - \$500,000 | <input type="checkbox"/> (26) \$5 million and over |

Do You Use Microsoft Windows

- | | |
|-----------------------------------|----------------------------------|
| <input type="checkbox"/> (31) Yes | <input type="checkbox"/> (32) No |
|-----------------------------------|----------------------------------|

If not, what operating system do you use? _____

Comments: _____

User Notes

User Notes

