

Triplex Ceramic  
Plunger Pump  
Operating Instructions/  
Repair and Service  
Manual

# Models HR2527A/HR3025/ HR3030 Pumps

---

Consumer Pumps

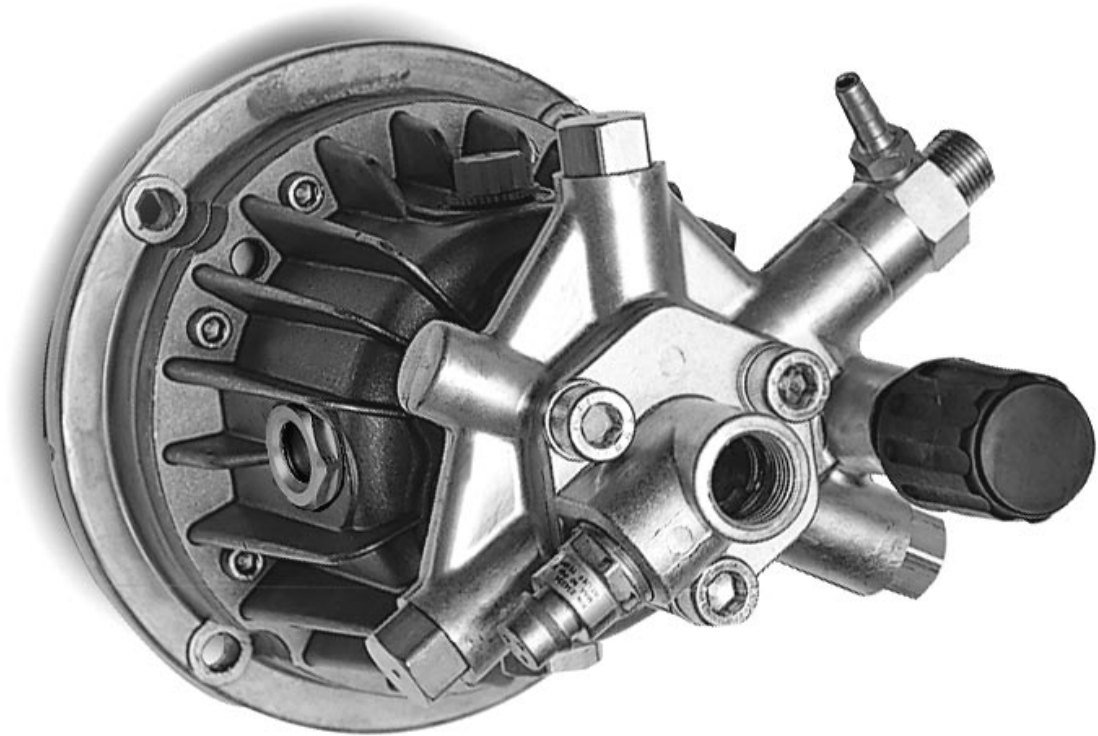

*HR2527A shown*

---

**GIANT**

MADE IN THE USA



Updated 5/02

**Contents:**

Installation Instructions:	page 2
Pump Specifications:	pages 3-5
Exploded View:	page 6
Parts List:	page 7
Kits/Torque Specs:	page 8
Trouble Shooting	page 9
Repair Instructions:	page 10-11
Dimensions/Warranty:	back page

# INSTALLATION INSTRUCTIONS

Installation of the Giant Industries, Inc., pump is not a complicated procedure, but there are some basic steps common to all pumps. The following information is to be considered as a general outline for installation. If you have unique requirements, please contact Giant Industries, Inc. or your local distributor for assistance.

1. The pump should be installed flat on a base to a maximum of a 15 degree angle of inclination to ensure optimum lubrication.
2. The inlet to the pump should be sized for the flow rate of the pump with no unnecessary restrictions that can cause cavitation. Teflon tape should be used to seal all joints. If pumps are to be operated at temperatures in excess of 80° F, it is important to insure a positive head to the pump to prevent cavitation.
3. The discharge plumbing from the pump should be properly sized to the flow rate to prevent line pressure loss to the work area. It is essential to provide a safety bypass valve

between the pump and the work area to protect the pump from pressure spikes in the event of a blockage or the use of a shut-off gun.

4. Reverse rotation may be safely achieved by following a few guidelines available upon request from Giant Industries, Inc. Required horsepower for system operation can be obtained from the charts on pages 3 and 6.
5. Before beginning operation of your pumping system, remember: Check that the crankcase and seal areas have been properly lubricated per recommended schedules. Do not run the pump dry for extended periods of time. Cavitation will result in severe damage. Always remember to check that all plumbing valves are open and that pumped media can flow freely to the inlet of the pump.

***NOTE: An anti-sieze material must be applied to the engine crankshaft to ensure trouble free disassembly of the pump.***

Finally, remember that high pressure operation in a pump system has many advantages. But, if it is used carelessly and without regard to its potential hazard, it can cause serious injury.

## IMPORTANT OPERATING CONDITIONS

**Failure to comply with any of these conditions invalidates the warranty.**

1. Crankcase oil should be changed after the first 50 hours of operation. Then at regular intervals of 500 hours or less depending on operating conditions.

**Use Giant synthetic oil**

2. Pump operation must not exceed rated pressure, volume, or RPM. A pressure relief device must be installed in the discharge of the system.

3. Acids, alkalines, or abrasive fluids cannot be pumped unless approval in writing is obtained before operation from Giant Industries, Inc.

4. Run the pump dry approximately 10 seconds to drain the water before exposure to freezing temperatures.

**NOTE: Contact Giant Industries for Service School Information. Phone: (419)-531-4600**

# Specifications

## Model HR2527A

### Axial Pump

Volume HR2527A .....	2.5 GPM
Maximum Discharge Pressure .....	2750 PSI
Maximum Inlet Pressure .....	Up to 90 PSIG <sup>1</sup>
RPM .....	3450
Plunger Diameter .....	16mm
Stroke .....	5.3mm (7.1 ° angle)
Crankcase Oil Capacity .....	4.5 fl. oz.
Temperature of Pumped Fluids .....	Up to 80 °F
Inlet Port .....	1 x 1/2" NPT
Discharge Ports .....	3/8" NPT
Shaft Rotation .....	Clockwise
Weight .....	11.7 lbs. (12.7 lbs.)
Width .....	6-9/16"
Height .....	7-25/32"
Swash Plate Bore .....	3/4" x 3/16" Keyway
Valve Type .....	Polyamide Plastic

<sup>1</sup> A 25 PSIG minimum inlet pressure is required.

HR2527A ELECTRIC HORSEPOWER REQUIREMENTS					
RPM	GPM	1000 PSI	1500 PSI	2000 PSI	2750 PSI
3450	2.5	1.7	2.6	3.4	4.7

HR2527A GAS HORSEPOWER REQUIREMENTS					
RPM	GPM	1000 PSI	1500 PSI	2000 PSI	2750 PSI
3450	2.5	2.3	3.4	4.5	6.3

#### HORSEPOWER RATINGS:

The rating shown are the power requirements for the pump. Gas engine power outputs must be approximately twice the pump power requirements shown above.

We recommend a 1.15 service factor be specified when selecting an electric motor as the power source. To compute specific pump horsepower requirements, use the Following formula:

$$\text{Electric HP} = (\text{GPM} \times \text{PSI}) / 1460$$

$$\text{Gas HP} = (\text{GPM} \times \text{PSI}) / 1100$$

# Specifications Model HR3025 Axial Pump

Volume HR3030 .....	3.0 GPM
Maximum Discharge Pressure .....	2500 PSI
Maximum Inlet Pressure .....	Up to 90 PSIG <sup>1</sup>
RPM .....	3450
Plunger Diameter .....	16mm
Stroke .....	5.9mm (8.0 ° angle)
Crankcase Oil Capacity .....	4.5 fl. oz.
Temperature of Pumped Fluids .....	Up to 80 °F
Inlet Port .....	1 x 1/2" NPT
Discharge Ports .....	3/8" NPT
Shaft Rotation .....	Clockwise
Weight .....	11.4 lbs.
Width .....	6-7/16"
Height .....	10-1/4"
Swash Plate Bore .....	3/4" x 3/16" Keyway
Valve Type .....	Polyamide Plastic

<sup>1</sup> A 25 PSIG minimum inlet pressure is required.

HR3025 ELECTRIC HORSEPOWER REQUIREMENTS					
RPM	GPM	1000 PSI	1500 PSI	2000 PSI	2500 PSI
3450	3.0	2.1	3.1	4.1	5.1

HR3025 GAS HORSEPOWER REQUIREMENTS					
RPM	GPM	1000 PSI	1500 PSI	2000 PSI	2500 PSI
3450	3.0	2.7	4.1	5.5	6.8

### HORSEPOWER RATINGS:

The rating shown are the power requirements for the pump. Gas engine power outputs must be approximately twice the pump power requirements shown above.

We recommend a 1.15 service factor be specified when selecting an electric motor as the power source. To compute specific pump horsepower requirements, use the Following formula:

$$\text{Electric HP} = (\text{GPM} \times \text{PSI}) / 1460$$

$$\text{Gas HP} = (\text{GPM} \times \text{PSI}) / 1100$$

# Specifications Model HR3030 Axial Pump

Volume HR3030 .....	3.0 GPM
Maximum Discharge Pressure .....	3000 PSI
Maximum Inlet Pressure .....	Up to 90 PSIG <sup>1</sup>
RPM .....	3450
Plunger Diameter .....	16mm
Stroke .....	5.9mm (8.0 ° angle)
Crankcase Oil Capacity .....	4.5 fl. oz.
Temperature of Pumped Fluids .....	Up to 80 °F
Inlet Port .....	1 x 1/2" NPT
Discharge Ports .....	3/8" NPT
Shaft Rotation .....	Clockwise
Weight .....	11.4 lbs.
Width .....	6-7/16"
Height .....	10-1/4"
Swash Plate Bore .....	1"x3/16" Keyway
Valve Type .....	Polyamide Plastic

<sup>1</sup> A 25 PSIG minimum inlet pressure is required.

<b>HR3030 ELECTRIC HORSEPOWER REQUIREMENTS</b>					
RPM	GPM	1500 PSI	2000 PSI	2500 PSI	3000 PSI
3450	3.0	3.1	4.1	5.1	6.2

<b>HR3030 GAS HORSEPOWER REQUIREMENTS</b>					
RPM	GPM	1500 PSI	2000 PSI	2500 PSI	3000 PSI
3450	3.0	4.1	5.5	6.8	8.2

#### HORSEPOWER RATINGS:

The rating shown are the power requirements for the pump. Gas engine power outputs must be approximately twice the pump power requirements shown above.

We recommend a 1.15 service factor be specified when selecting an electric motor as the power source. To compute specific pump horsepower requirements, use the Following formula:

$$\text{Electric HP} = (\text{GPM} \times \text{PSI}) / 1460$$

$$\text{Gas HP} = (\text{GPM} \times \text{PSI}) / 1100$$

# HR2527A/HR3025/HR3030 EXPLODED VIEW

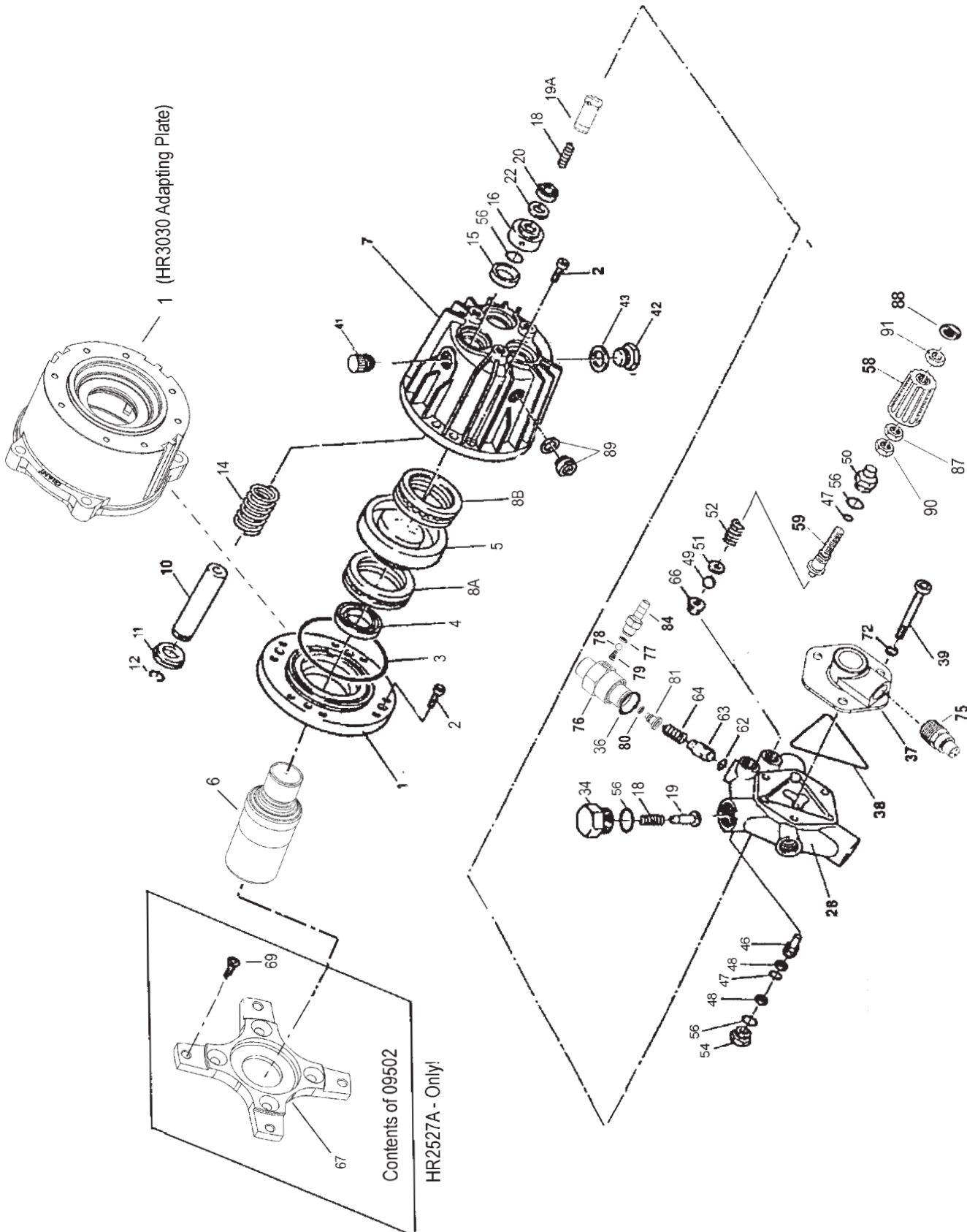

## HR2527A/HR3025/HR3030 SERIES PARTS LIST

ITEM	PART #	DESCRIPTION	QTY.	ITEM	PART #	DESCRIPTION	QTY.
1*	06311	Adapting Plate (HR2527A/HR3025)	1	46	06423	Piston	1
1*	06403	Adapting Plate (HR3030)	1	47	07937	O-Ring	2
2	07881A	Socket Head Cap Screw 1/4"	8	48	12031-0002	Back-Up Ring	2
3	07344	O-Ring	1	49	06227	Ball, By Pass Valve	1
4	07805	Radial Shaft Seal	1	50	06324	Adjusting Plug	1
5**	06419	7.1° Piece Wobble Plate (HR2527A)	1	51	07917A	Washer	1
5**	06402	8° Wobble Plate (HR3025/HR3030)	1	52	06608	Adjusting Spring	1
6	06393	Steel Shaft 3/4" (HR2527A/HR3025)	1	54	06239	Guide Plug	1
6	06401	Steel Shaft 1" (HR3030)	1	56	12007	O-Ring	8
7	08089	Crankcase	1	58	07045	Handwheel	1
8A*	06300	Rear Bearing, Complete	1	59	06524	Adjusting Screw	1
8B**	06301	Front Bearing, Complete	1	62	12326	O-Ring	1
10	06319	Plunger	3	63	12325	Kick-Back Valve Cone	1
11	06318	Spring Disc Retainer	3	64	12328	Kick-Back Valve Spring	1
12	06291	Clip Ring	3	66	07935A	By Pass Valve Seat	1
14	07873	Plunger Spring	3	67+	06414	Mounting Flange "X" Style (HR2527)	1
15	06316	Oil Seal	3	69+	07467	Bolt (HR2527)	4
16	06317	Spacer Ring	3	72	06224	Washer	3
18	07374	Valve Spring	6	75	23422A	Thermal Valve	1
19	06295	Valve Cone (Discharge)	3	76	06306	Injector Retainer	1
19A	06267	Valve Cone (Inlet)	3	77	12516-001	O-Ring Viton	1
20	06315	V-Sleeve	3	78	23010-0100	Ball, 7/32" Dia. ss	1
22	06290	Pressure Ring	3	79	23009	Spring, Injector	1
28	06424	Manifold	1	80	06312	O-Ring	1
34	07379	Manifold Plug	3	81	06339	Oriface, 2.1mm	1
36	07913	O-Ring	1	84	12517	Hose Barb	1
37	06313	Suction Flange	1	87	07044	Locknut	1
38	07910A	O-Ring, Flange	1	88	07046	Cover	1
39	06320	Stud Bolt	3	89	08250	Sightglass w/gasket	1
41	08083	Oil Fill Cap	1	90	07939	Nut	1
42	06273	Oil Drain Plug	1	91	07068	Locknut w/Nylon Insert	1
43	08192	Gasket	1				

+ 09502 Gasoline Flange kit

\* When ordering a 06311 please order 17021 which includes 06311, 07344, 07805, 06300 - HR2527A/HR3025

\* When ordering a 06403, please order 17038 which includes 06403, 07344, 07805, 06300 - HR3030

\*\* When ordering 06419, please order 17036, which includes 06419, 06393, & 06301 - HR2527A

\*\* When ordering 06402, please order 17051, which includes 06402, 06393 & 06301 - HR3025

\*\* When ordering 06402, please order 17040, which includes 06402, 06401, & 6301 - HR3030

## HR2527A/HR3025/HR3030 Repair Kits

### Plunger Packing Kit # 09465

<u>Item</u>	<u>Part #</u>	<u>Description</u>	<u>Qty.</u>
22	06290	Pressure Ring	3
20	06315	V-Sleeve	3

### Unloader Repair Kit # 09235

<u>Item</u>	<u>Part #</u>	<u>Description</u>	<u>Qty.</u>
36	07913	O-Ring	1
47	07937	O-Ring, Adjusting Screw	2
48	12031-0002	Teflon Back-Up Ring	2
49	06227	8mm Ball	1
56	12007	O-Ring	2
62	12326	O-Ring	1
66	07935A	By Pass Seat	1

### Valve Assembly Kit # 09475

<u>Item</u>	<u>Part #</u>	<u>Description</u>	<u>Qty.</u>
18	07374	Valve Spring	6
19A	06267	Guided P-Valve	3
19	06295	Discharge Valve Cone	3

### Oil Seal Kit # 09468

<u>Item</u>	<u>Part #</u>	<u>Description</u>	<u>Qty.</u>
15	06316	Plunger Oil Seal	3

## HR2527A/HR3025/HR3030 SERIES TORQUE SPECIFICATIONS

<u>Position</u>	<u>Item#</u>	<u>Description</u>	<u>Torque Amount (ft.-lbs)</u>
2	07881A	Socket Head Cap Screw 1/4"	100in.-lbs.
39	06320	Stud Bolt	360in.-lbs.

## GX and HR Pump Part Numbering System

GX or HR Series	Flow	Pressure (in 100 psi increments)		Injector Size	Thermal Relief Valve	Wobble Plate Shaft Bore
Vertical	20=GPM	25=2500 PSI		1=2.1 mm	1=1/2"	1=3/4"
Horizontal	23=GPM			2=1.8mm		2=7/8"
	25=GPM			3=2.3mm		3=1"
						4=5/8"
GX or HR	2.5	25	-	1	1	1

For example, a GXV2525-112 is a GX pump that produces 2.5 GPM @ 2500 PSI, has a injector with a 2.1mm Oriface, 1/2" thermal relief valve and 7/8" wobble plate bore.



## PUMP TROUBLE SHOOTING

<u>MALFUNCTION</u>	<u>CAUSE</u>	<u>REMEDY</u>
The Pressure and/or the Delivery Drops	Worn packing seals Broken valve spring Worn or Damaged nozzle Fouled discharge valve Fouled inlet strainer Worn or Damaged hose Worn or Plugged relief valve on pump Cavitation	Replace packing seals Replace spring Replace nozzle Clean valve assembly Clean strainer Repair/Replace hose Clean, Reset, and Replace worn parts Check suction lines on inlet of pump for restrictions
Water in crankcase	High humidity Worn seals	Reduce oil change interval Replace seals
Noisy Operation	Worn bearings  Cavitation	Replace bearings, Refill crankcase oil with recommended lubricant Check inlet lines for restrictions and/or proper sizing
Rough/Pulsating Operation with Pressure Drop	Worn packing Inlet restriction  Cavitation	Replace packing Check system for stoppage, air leaks, correctly sized inlet plumbing to pump  Check inlet lines for restrictions and/or proper size
Pressure Drop at Gun	Restricted discharge plumbing	Re-size discharge plumbing to flow rate of pump
Excessive Leakage	Worn plungers Worn packing/seals Excessive vacuum Inlet pressure too high	Replace plungers Adjust or Replace packing seals Reduce suction vacuum Reduce inlet pressure
High Crankcase Temperature	Wrong Grade of oil Improper amount of oil in crankcase	Giant oil is recommended Adjust oil level to proper amount

## REPAIR INSTRUCTIONS - HR2527A/HR3025/HR3030

**NOTE:** Always take time to lubricate all metal and nonmetal parts with a light film of oil before reassembly. This step will ensure proper fit, at the same time protecting the pump's nonmetal parts (elastomers) from cutting and scoring.

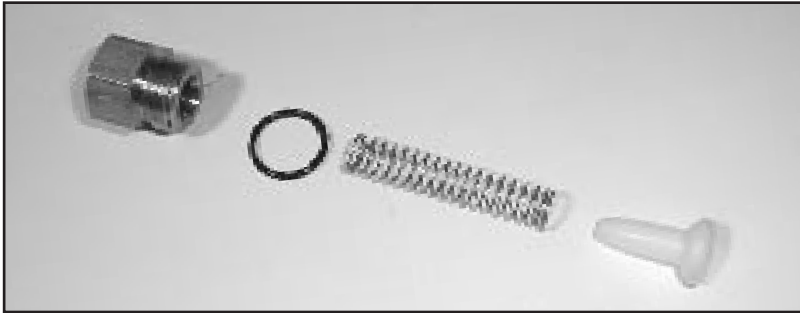

1. With a 19mm socket wrench, remove the three discharge valve plugs (34). Inspect the valve plug o-rings (56) for wear, and replace as necessary. Remove the valve spring (18) and valve cone (19) from the manifold (28). Inspect the parts for wear and replace as necessary.
2. With a 19mm crescent wrench, remove the adjusting screw assembly (50, 56, 47, and 59). Unscrew the adjusting screw (59) from the adjusting screw plug (50).



3. With a crescent wrench, remove the injector retainer (76).

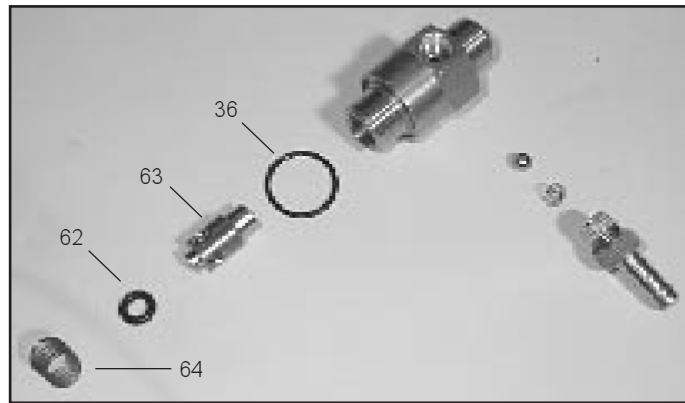

4. Inspect the o-ring (36) for wear and replace as necessary. Remove the kickback valve spring (64), kickback valve cone (63), and the o-ring (62) from the manifold (28). Inspect and clean the siphon injector and ball clean parts for wear and replace as necessary.

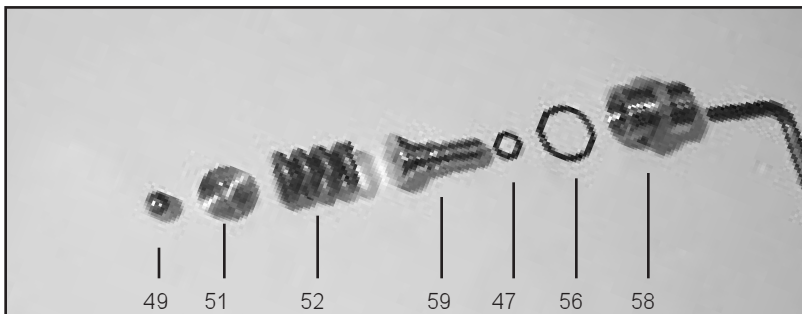

5. Inspect the o-rings (56 and 47) for wear and replace as necessary. Remove the adjusting spring (52), washer (51) and by pass valve ball (49) from the manifold (28). Inspect the parts for wear and replace as necessary.
6. Next, remove the three manifold stud nuts (39) with a 17mm wrench. Remove the suction flange (37) and flange o-ring (38). Inspect the o-ring for wear and replace as necessary.



## REPAIR INSTRUCTIONS - HR2527A/HR3025/HR3030

**NOTE:** Always take time to lubricate all metal and nonmetal parts with a light film of oil before reassembly. This step will ensure proper fit, at the same time protecting the pump's nonmetal parts (elastomers) from cutting and scoring.

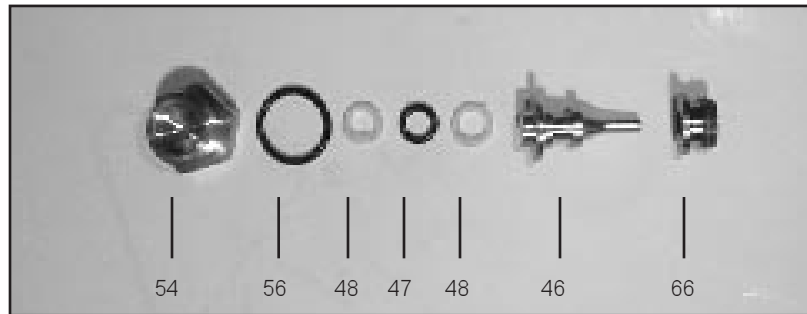

7. Tap the back of the manifold (28) with a rubber mallet to dislodge, and slide off the plungers (10). Take note of the position of the discharge port so as to place the port in the same position during reassembly.
8. With a 19mm socket wrench, remove the guide plug (54) and o-ring (56) from the manifold (28). Remove the piston (46), o-ring (47), and backup rings (48). Using a 7/32" Allen wrench, remove the bypass valve seat (66). Inspect the parts for wear and replace as necessary.

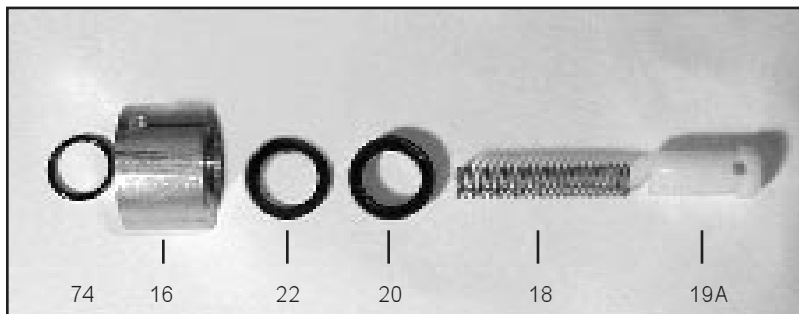

9. Remove the valve cones (19A), valve springs (18), v-sleeves (20) and pressure rings (22). Inspect for wear and replace as necessary. Remove the spacer ring (16) and flinger (56) from the plungers (10).
10. If the crankcase oil seals (15) are to be replaced, they can be removed by prying loose with a small screwdriver. Take care not to make contact with the plunger (10) and pry out the oil seals from their housing.
11. Reassemble in reverse order. Fill the crankcase until the proper amount of oil (see specifications page 3). The pump is now ready for operation.

**Contact Giant Industries for service school information. Phone: (419) 531-4600**

**HR2527A/HR3025/HR3030  
SERIES DIMENSIONS**

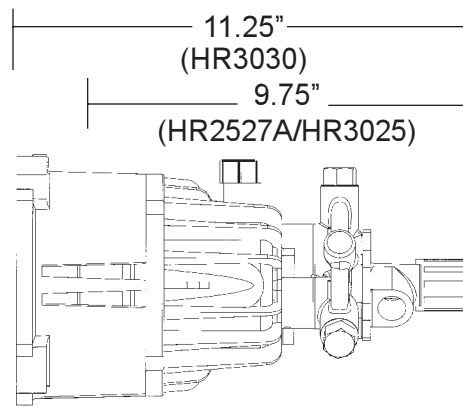
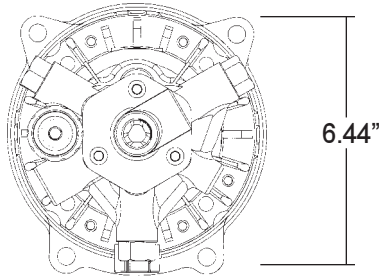

## **GIANT INDUSTRIES LIMITED WARRANTY**

Giant Industries, Inc. pumps and accessories are warranted by the manufacturer to be free from defects in workmanship and material as follows:

1. For portable pressure washers and self-service car wash applications, the discharge manifolds are guaranteed for the life of the pump. Our other pump parts, used in portable pressure washers and in car wash applications, are warranted for five years from the date of shipment for all pumps used in NON-SALINE, clean water applications.
2. One (1) year from the date of shipment for all other Giant industrial and consumer pumps.
3. Six (6) months from the date of shipment for all rebuilt pumps.
4. Ninety (90) days from the date of shipment for all Giant accessories.

This warranty is limited to repair or replacement of pumps and accessories of which the manufacturer's evaluation shows were defective at the time of shipment by the manufacturer. The following items are NOT covered or will void the warranty:

1. Defects caused by negligence or fault of the buyer or third party.
2. Normal wear and tear to standard wear parts.
3. Use of repair parts other than those manufactured or authorized by Giant.
4. Improper use of the product as a component part.
5. Changes or modifications made by the customer or third party.
6. The operation of pumps and or accessories exceeding the specifications set forth in the Operations Manuals provided by Giant Industries, Inc.

Liability under this warranty is on all non-wear parts and limited to the replacement or repair of those products returned freight prepaid to Giant Industries which are deemed to be defective due to workmanship or failure of material. A Returned Goods Authorization (R.G.A.) number and completed warranty evaluation form is required prior to the return to Giant Industries of all products under warranty consideration. Call (419)-531-4600 or fax (419)-531-6836 to obtain an R.G.A. number. A complete copy of our current RGA policy may be obtained from Giant Industries by written request.

Repair or replacement of defective products as provided is the sole and exclusive remedy provided hereunder and the MANUFACTURER SHALL NOT BE LIABLE FOR FURTHER LOSS, DAMAGES, OR EXPENSES, INCLUDING INCIDENTAL AND CONSEQUENTIAL DAMAGES DIRECTLY OR INDIRECTLY ARISING FROM THE SALE OR USE OF THIS PRODUCT.

THE LIMITED WARRANTY SET FORTH HEREIN IS IN LIEU OF ALL OTHER WARRANTIES OR REPRESENTATION, EXPRESS OR IMPLIED, INCLUDING WITHOUT LIMITATION ANY WARRANTIES OR MERCHANTABILITY OR FITNESS FOR A PARTICULAR PURPOSE AND ALL SUCH WARRANTIES ARE HEREBY DISCLAIMED AND EXCLUDED BY THE MANUFACTURER.



GIANT INDUSTRIES, INC., 900 N. Westwood Ave., P.O. Box 3187, Toledo, Ohio 43607  
PHONE (419) 531-4600 FAX (419) 531-6836, [www.giantpumps.com](http://www.giantpumps.com)  
© Copyright 2001 Giant Industries, Inc.