

UNO-3072L

**Celeron M/ Pentium M
Embedded Automation
Computer with Two
PCI-Slot Extensions**

User Manual

Copyright

This document is copyrighted, © 2009. All rights are reserved. The original manufacturer reserves the right to make improvements to the products described in this manual at any time without notice.

No part of this manual may be reproduced, copied, translated or transmitted in any form or by any means without the prior written permission of the original manufacturer. Information provided in this manual is intended to be accurate and reliable. However, the original manufacturer assumes no responsibility for its use, nor for any infringements upon the rights of third parties that may result from such use.

Acknowledgements

Intel[®], Pentium[®] and Celeron[®] are registered trademarks of Intel Corporation. Microsoft[®] Windows and MS-DOS are registered trademarks of Microsoft[®] Corp. All other product names or trademarks are properties of their respective owners.

Support

For more information on this and other Advantech products, please visit our websites at: <http://www.advantech.com>

For technical support and service, please visit our support website at: <http://www.advantech.com/support/>

Part No. 2003307233 5th Edition

Printed in Taiwan June 2009

Product Warranty (2 years)

Advantech warrants to you, the original purchaser, that each of its products will be free from defects in materials and workmanship for two years from the date of purchase.

This warranty does not apply to any products that have been repaired or altered by persons other than repair personnel authorized by Advantech, or which have been subject to misuse, abuse, accident or improper installation. Advantech assumes no liability under the terms of this warranty as a consequence of such events.

Because of Advantech high quality-control standards and rigorous testing, most of our customers never need to use our repair service. If an Advantech product is defective, it will be repaired or replaced at no charge during the warranty period. For out-of-warranty repairs, you will be billed according to the cost of replacement materials, service time and freight. Please consult your dealer for more details. If you think you have a defective product, follow these steps:

Step 1: Collect all the information about the problem encountered. (For example, CPU speed, Advantech products used, other hardware and software used, etc.) Note anything abnormal and list any on- screen messages you get when the problem occurs.

Step 2: Call your dealer and describe the problem. Please have your manual, product, and any helpful information readily available.

Step 3: If your product is diagnosed as defective, obtain an RMA (return merchandise authorization) number from your dealer. This allows us to process your return more quickly.

Step 4: Carefully pack the defective product, a fully completed Repair and Replacement Order Card and a photocopy proof of purchase date (such as your sales receipt) in a shippable container. A product returned without proof of the purchase date is not eligible for warranty service.

Step 5: Write the RMA number visibly on the outside of the package and ship it prepaid to your dealer.

CE

This product has passed the CE test for environmental specifications. Test conditions for passing included the equipment being operated within an industrial enclosure. In order to protect the product from being damaged by ESD (Electrostatic Discharge) and EMI leakage, we strongly recommend the use of CE-compliant industrial enclosure products.

FCC Class A

This equipment has been tested and found to comply with the limits for a Class A digital device, pursuant to Part 15 of the FCC Rules. These limits are designed to provide reasonable protection against harmful interference when the equipment is operated in a commercial environment. This equipment can generate, use and radiate radio frequency energy and, if not installed and used in accordance with the instruction manual, may cause harmful interference to radio communications. Operation of this equipment in a residential area is likely to cause harmful interference in which case the user will be required to correct the interference at his own expense.

CAUTION

The computer is provided with a battery-powered real-time clock circuit. There is a danger of explosion if battery is incorrectly replaced. Replace only with same or equivalent type recommended by the manufacture. Discard used batteries according to the manufacturer's instructions.

Technical Support and Assistance

Step 1: Visit the Advantech web site at **www.advantech.com/support** where you can find the latest information about the product.

Step 2: Contact your distributor, sales representative, or Advantech's customer service center for technical support if you need additional assistance. Please have the following information ready before you call:

- Product name and serial number
- Description of your peripheral attachments
- Description of your software (OS, version, application software, etc.)
- A complete description of the problem
- The exact wording of any error messages

Contents

Chapter 1	Overview	2
1.1	Introduction	2
1.2	Hardware Specifications	5
1.3	Safety Precautions	7
1.4	Chassis Dimensions	8
1.5	Packing List	10
Chapter 2	Hardware Functionality	12
2.1	Introduction	12
2.2	RS-232 Interface (COM1~COM2)	13
2.3	RS-232/422/485 Interface (COM3~COM4)	13
2.3.1	16C550 UARTs with 16-byte FIFO Standard	13
2.3.2	RS-422/485 Detection	13
2.3.3	Automatic Data Flow Control Function for RS-485 ..	13
2.3.4	RS-232/422/485 Selection	14
2.3.5	RS-485 Auto Flow/RS-422 Master/Slave Selection ..	15
2.3.6	IRQ, I/O Address and Transmission Rate Setting ..	16
2.3.7	Termination Resistor (JP6)	17
2.4	LAN: Ethernet Connector	17
2.5	Onboard Isolated Digital Input	17
2.5.1	Pin Assignments	18
2.5.2	Isolated Inputs	19
2.5.3	Interrupt Function of the DI Signals	20
2.5.4	IRQ Level	20
2.5.5	Interrupt Control Register	20
2.5.6	Interrupt Enable Control Function	21
2.5.7	Interrupt Triggering Edge Control	21
2.5.8	Interrupt Flag Bit	22
2.6	Onboard Isolated Digital Output	22
2.6.1	Pin Assignments	22
2.6.2	Power On Configuration	23
2.6.3	Isolated Outputs	24
2.7	Onboard Isolated Counter/Timer	25
2.7.1	Counter/Timer Control Register	25
2.7.2	Counter 0 Function Block	27
2.7.3	Counter 1 Function Block	27
2.7.4	32-bit Counter Function Block (CTR32Set=1)	28
2.7.5	Counter Clock Source	28
2.7.6	Counter Internal Clock	28
2.7.7	Counter Gate Source	29
2.7.8	Counter Output Destination	29
2.7.9	Counter Interrupt Flag	29
2.7.10	Cascaded 32-bit Counter	30

2.8	Power Input	31
2.9	LED and Buzzer for System Diagnosis.....	33
2.10	PS/2 Keyboard and Mouse Connector	34
2.11	USB Connector	34
2.12	VGA Display Connector	35
2.13	Reset Button	35
Chapter 3	Initial Setup.....	38
3.1	Inserting a CompactFlash Card	38
3.2	Connecting Power	38
3.3	Installing a Hard Disk	39
3.4	Installing a PCI-bus Card	45
3.5	Mounting UNO-3072L.....	47
3.6	Installing Power Cable	47
3.7	UNO-3072L Mounting Caution.....	48
3.8	BIOS Setup and System Assignments	49
Appendix A	System Settings and Pin Assignments	52
A.1	System I/O Address and Interrupt Assignments	52
A.2	Board Connectors and Jumpers.....	54
A.3	UNO-3072L Control Register.....	57
A.4	RS-232 Standard Serial Port (COM1~COM2)	58
A.5	RS-232/422/485 Serial Port (COM3~COM4)	59
A.6	Ethernet RJ-45 Connector (LAN1~LAN2).....	59
A.7	Power Screw Terminal (PWR).....	60
A.8	PS/2 Keyboard and Mouse Connector	61
A.9	USB Connector (USB1~USB4).....	61
A.10	VGA Display Connector	62
Appendix B	Programming the Watchdog Timer	64
B.1	Watchdog programming.....	64

Overview

This chapter provides an overview of UNO-3072L specifications.

Sections include:

- Introduction
- Hardware specification
- Safety precautions
- Chassis dimensions

Chapter 1 Overview

1.1 Introduction

Standard PCs and some industrial computers with a standard OS and hardware for the consumer market cannot provide the reliability required by industrial automation and embedded industrial control applications. However, many engineers prefer to use PCs because of their advanced functions such as: analog control and simulation, database connectivity, web-based applications, and communication with third-party devices. UNO-3072L combines the best features of a PC, including the processor, RAM, and powerful software, with the reliability, ruggedness, and distributed nature of a PLC. UNO-3072L has the compact size and ruggedness of a PLC, and the software flexibility and functionality of a PC. It's an ideal platform for sophisticated control and logging in rugged environments.

Open Architecture Designed for Automation

For applications demanding customized control, UNO-3072L that uses more flexible, off-the-shelf technology is a better option. UNO-3072L uses off-the-shelf components such as an x86 processor, an Ethernet chip set, CompactFlash and DRAM. System designers can easily create multiple inputs from sensors via plug-in data acquisition cards and provide outputs to other devices to control the operation. At the same time, the UNO-3072L unit can broadcast the process data through the Ethernet and share the data with operators and managers. By using off-the-shelf components, machine builders can customize the control scheme they use for other machines that require multiple inputs, optimized control, or Ethernet communication. So, UNO-3072L offers the I/O connectivity of PCs with options such as 2 x 10/100Base-T Ethernet, 2 x RS-232, 2 x RS-232/422/485, 4 x USB, CompactFlash and PCI extension slots and VGA interfaces for display panels.

An Industry-Proven Design

Industrial and mobile applications require controllers with high-vibration specifications and a wide temperature range. Machines or controllers in light industrial environments also require flexible and stable mounting. Many machine builders underestimate the need for a more rugged controller because their end applications are mounted in an industrial enclosure. Advantech UNO-3072L has a special design without the weaknesses of a standard PC. No fan and no HDD design prevent dust and vibration problems. A battery-backup function secures the last state of the system, making system crashes less problematic. With a smart mechanical design, UNO-3072L can meet 50G shock, 2G vibration, up to 55° operating temperature and almost everything a harsh industrial environment demands.

Off-the-shelf Universal PCI Extensions

From a computing point of view, the UNO-3072L with its PC-based control CPU is a high-end machine controller. It can be simply operated with the onboard Ethernet interface or with a PC Fieldbus card. Two free PCI slots are also available. In addition, Advantech offers a complete product line for plug-in data acquisition and control I/O cards, motion control cards, GPIB cards, industrial communication and Fieldbus communication cards, providing a complete PC-based solution.

Front Access Connections

All PC connections are on one side of the housing. The PC can optionally be equipped with mounting plates and fastened with screws in a control cabinet. All mechanical parts have a simple design, and the drivers and plug-in cards are easily accessible without compromising system performance or integrity. The installation options are also well balanced.

Designed to Fit Into Control Cabinets

The fully-fledged UNO-3072L could easily be mistaken for a PLC by its look and feel. In completely new packaging, the smallest UNO only measures 140 x 177 x 237 mm (W x H x D). But the UNO-3072L not only deals with PLC tasks, but also offers all the operating and communication power of a modern PC with its Intel Celeron M or Pentium M processor and Windows Operating System software. So, Advantech UNO-3072L is a small, powerful and inexpensive PLC substitute.

Onboard DI/O for Counter, Alarm/Event Handling

UNO-3072L features onboard DI and DO. These DIs and DOs can be used as 32-bit counters or to handle alarms and events. Any events can be passed to UNO-3072L through DIs with an additional DI plug-in card.

UNO-3072L can also output alarms through onboard DOs immediately to notify key personnel about urgent events.

Flexible Networking Options

UNO-3072L offers two ways to connect to a network: Ethernet and Modem. The two built-in Ethernet ports provide high-speed networking capability up to 100 Mbps. And through COM ports of UNO-3072L, industrial modems offer the most popular and easiest networking method by PSTN.

Popular Operating Systems and Rapid Application Development

UNO-3072L supports the popular off-the-shelf Windows 2000/XP operating systems and the Linux operating system. UNO-3072L also features pre-built Microsoft Windows XP embedded or Windows CE solutions offering a pre-configured image with optimized onboard device drivers. Microsoft Windows CE and XP Embedded are compact, highly efficient, and real-time operating systems that are designed for embedded systems without a HDD. There is no need to waste time and energy on developing onboard device drivers or using the Platform Builder to build a custom Windows CE image, they have all been done for the Advantech UNO-3000 series. Through the built-in runtime library and Software Development Kit (SDK), the UNO-3000 series leverages your existing Windows-based programming skills to rapidly develop applications.

1.2 Hardware Specifications

- **CPU:** Celeron M 1GHz CPU (non-cache)
- **Memory:** 1x 200 pin SODIMM socket, supports up to 1GB DDR RAM
- **BIOS:** Award 4MB flash memory, supports Boot-on-LAN function
- **Interface I/O:** VGA/Keyboard/Mouse DB-15 VGA Connector,
PS/2 keyboard and mouse
- **Clock:** Battery-backup RTC for time and date
- **Serial Ports:** 2 x RS-232 and 2 x RS-232/422/485 w/ DB-9 connector and Automatic RS-485 data flow control
- **RS-232 Speed:** 50 bps ~ 115.2 kbps
- **RS-422/485 Speed:** 50 bps ~ 921.6 kbps
- **LAN:** Two 10/100Base-T RJ-45 ports
- **USB Interface:** Four USB ports, USB UHCI, Rev. 2.0 compliant
- **CompactFlash Slots:** One internal
- **LEDs:** Power, Power inputs 1& 2, Power fault, IDE and Diagnosis
- **Two PCI-bus Slots support:**
 - 12 V @ 2.5 A
 - 12 V @ 0.8 A
 - 5 V @ 4 A
 - 3.3 V @ 3 A
- **4-ch Isolated Digital Input (DI0~DI3)**
 - 2,000 V_{DC} isolation
 - 70 V_{DC} over-voltage protection
 - -50~50 V_{DC} input range and 10 kHz speed
 - Input Voltage Range:
 - Logic 0: -3 ~ 3 V_{DC}
 - Logic 1: -50 ~ -10 V_{DC}, 10 ~ 50 V_{DC}
 - Input Current:
 - 10 V_{DC}: 1.7 mA (typical)
 - 12 V_{DC}: 2.1 mA (typical)

24 V_{DC}: 4.4 mA (typical)

48 V_{DC}: 9.0 mA (typical)

50 V_{DC}: 9.4 mA (typical)

- Interrupt handling capability

• **4-ch Isolated Digital Output (DO0~DO3)**

- 2,000 V_{DC} isolation and 200 mA max / channel sink current

- Two options after hot reset: Reset all digital output or keep last status

- 5 ~ 40 V_{DC} output range and 10 kHz speed

• **Two 16-bit Counters/Timers:**

- Counter source: DI1 & DI3, Pulse output: DO2 & DO3

- Can be cascaded as one 32-bit counter/timer

- Down counting, preset counting value

- Interrupt handling, speed: 40 kHz

- Internal timer time base: 100 kHz, 10 kHz, 1 kHz, 100 Hz

• **HDD:** HDD extension kit for installation of one standard 2.5" (option)

(SATA HDD support only for UNO-3072L-C11BE & UNO-3072L-C22BE)

• **Anti-Shock:**

20 G @ Wall mounting, IEC 68 section 2-27, half sine, 11 ms w/HDD

50 G @ Wall mounting, IEC 68 section 2-27, half sine, 11 ms w/CF

• **Anti-Vibration:**

2 Grms w/ CF @IEC 68 section 2-64, random, 5~500Hz, 1 Oct./min, 1 hr/axis.

1 Grms w/HDD@IEC 68 section 2-64, random, 5~500Hz, 1 Oct./min, 1 hr/axis

• **Power Supply:** 16 ~ 36 V_{DC}

• **Operating Temperature:** -10 ~ 55°C (14 ~ 131°F)

Note: The temperature inside the chassis may be 5° to 10°C higher than the ambient temperature. To ensure stable performance, please make sure the operating temperature of the installed PCI add-on card is equal to or higher than 60°C.

• **Relative Humidity:** 0~95% @ 40°C

- **Power Consumption:** 24 W
- **Power Requirements:** Min 48 W, (16~36 V_{DC}) (e.g. +24 V @ 2 A)
- **Chassis Size (WxHxD):** 140 x 177 x 237 mm
(5.5"x 7.0"x9.3") for C-M 1G
153.4 x 177 x 237 mm
(6"x 7.0"x 9.3") for C-M 1.5G or faster CPU
- **Mounting:** Wall/Panel/Stand mount
- **Weight:** 4.2 kg
- **Software OS:** Microsoft Windows XP Embedded, Windows CE 5.0, Windows 2000/XP, Linux

1.3 Safety Precautions

The following messages inform how to make each connection. In most cases, you will simply need to connect a standard cable.

Note: Always disconnect the power cord from your chassis whenever you are working on it. Do not connect while the power is on. A sudden rush of power can damage sensitive electronic components. Only experienced electronics personnel should open the chassis.

Note: Always ground yourself to remove any static electric charge before touching UNO-3072L. Modern electronic devices are very sensitive to static electric charges. Use a grounding wrist strap at all times. Place all electronic components on a static-dissipative surface or in a static-shielded bag.

Note: If DC voltage is supplied by an external circuit, please put a protection device in the power supply input port.

1.4 Chassis Dimensions

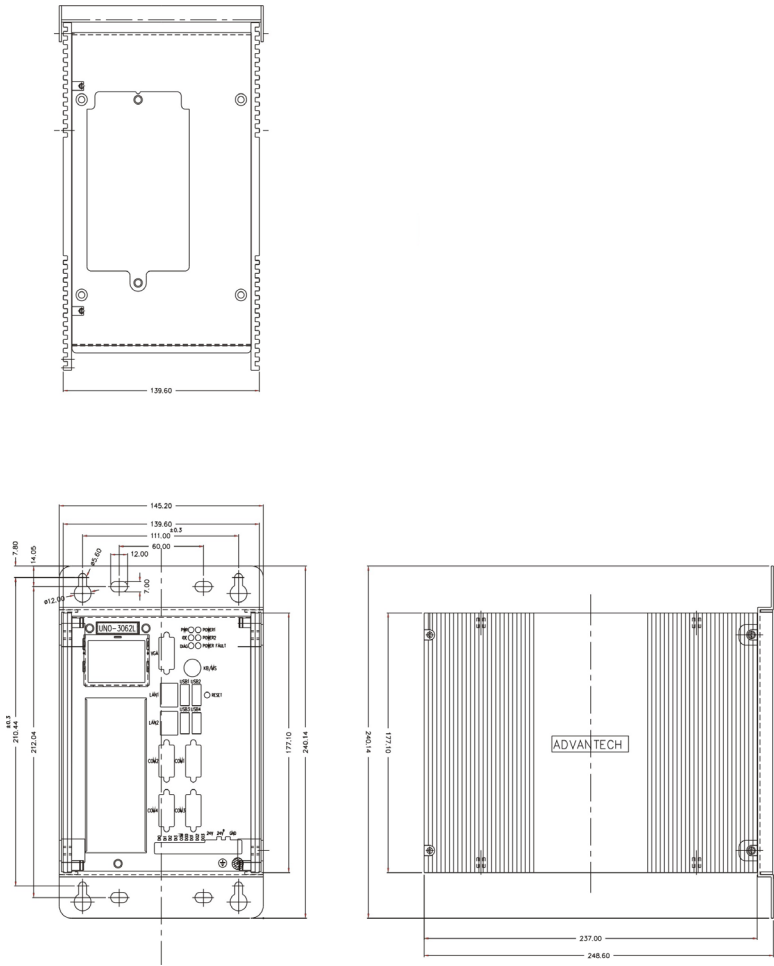

Figure 1.1: Chassis Dimensions for C-M 1GHz CPU

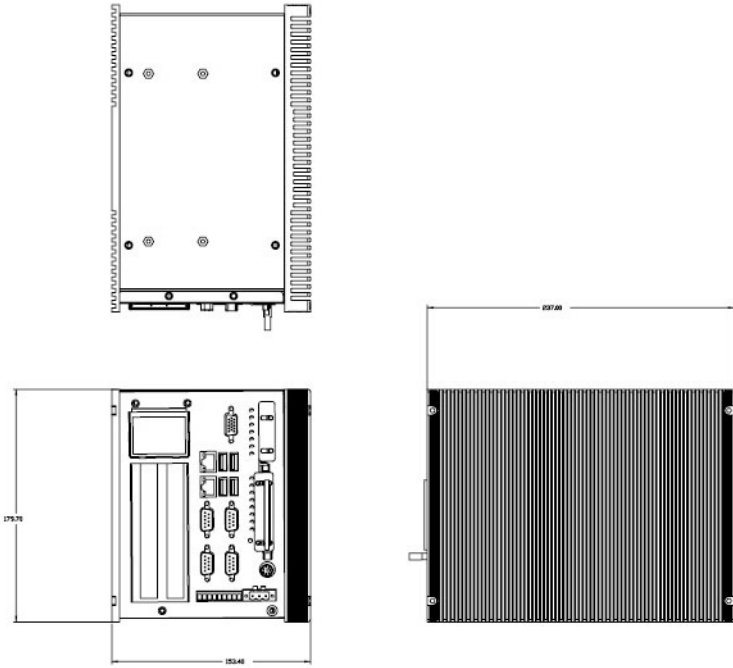

Figure 1.2: Chassis Dimensions for C-M 1.5GHz or faster CPU

1.5 Packing List

The accessory package of UNO-3072L contains the following items:

- (A) Power cable
- (B) Keyboard/ Mouse PS/2 cable
- (C) Warranty card
- (D) Driver and Utility CD-ROM
- (E) 2 x nti-vibration rubber
- (F) PCI expansion to hold 2nd anti-vibration rubber
- (G) Mini Jumper
- (H) Paper menu
- (I) Power connector
- (J) IDE cable for 2.5" HDD
- (K) IDE to SATA converter board (Only for UNO-3072L-C11BE & UNO-3072L-C22BE)

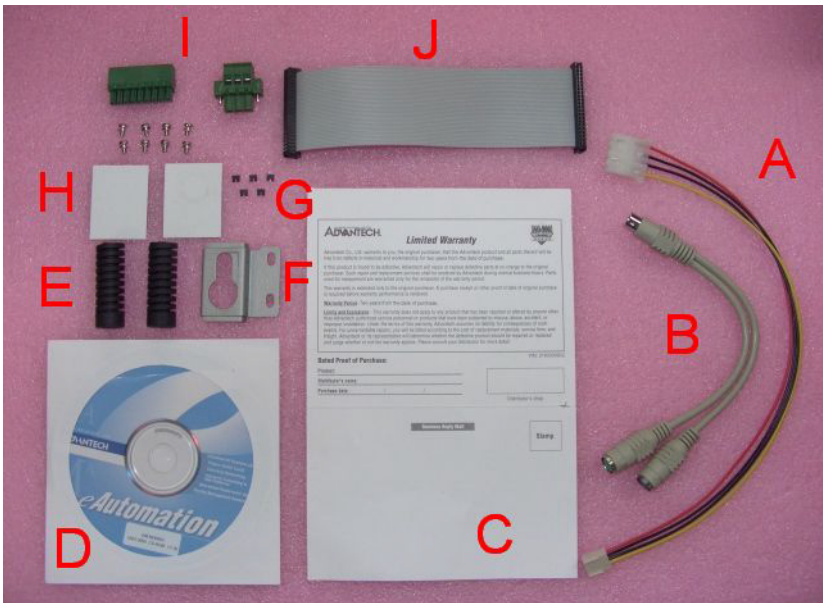

Figure 1.3: UNO-3072L Accessories

Hardware Functionality

This chapter shows how to setup the UNO-3072L hardware functions, including connecting peripherals, and setting switches and indicators.

Sections include:

- Introduction
- RS-232 Interface
- RS-232/422/485 Interface
- LAN / Ethernet Connector
- DI/O and Counter
- Power Connector
- LED and Buzzer
- PS/2 Mouse and Keyboard Connector
- USB Connector
- VGA Display Connector
- Reset Button

Chapter 2 Hardware Functionality

2.1 Introduction

The figures below show the connectors on UNO-3072L, and following sections give you detailed information about function of each peripheral.

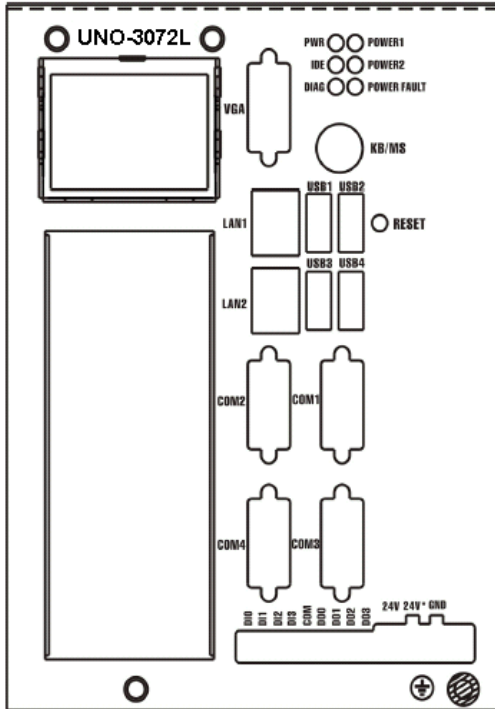

Figure 2.1: Front Panel of UNO-3072L

2.2 RS-232 Interface (COM1~COM2)

The UNO-3072L offers two industrial standard RS-232 serial communication interface ports: COM1 and COM2. Please refer to Appendix A.4 for their pin assignments.

The IRQ and I/O address range of COM1 and COM2 are listed below:

COM1: 3F8_H, IRQ4 COM2: 2F8_H, IRQ3

2.3 RS-232/422/485 Interface (COM3~COM4)

The UNO-3072L offers two industrial RS-232/422/485 serial communication interface ports: COM3 and COM4. Please refer to Appendix A.5 for their pin assignments. The default setting of COM3 and COM4 are RS-422/485. (Please refer to section 2.3.4 for how to determine RS-232 or RS-422/485)

2.3.1 16C550 UARTs with 16-byte FIFO Standard

Advantech UNO-3072L comes with 16C550 UARTs containing 16 bytes FIFOs.

2.3.2 RS-422/485 Detection

In RS-422/485 mode, UNO-3072L automatically detects signals to match RS-422 or RS-485 networks. (Refer to section 2.3.5)

2.3.3 Automatic Data Flow Control Function for RS-485

In RS-485 mode, UNO-3072L automatically detects the direction of incoming data and switches its transmission direction accordingly. So no handshaking signal (e.g. RTS signal) is necessary. This lets you easily build an RS-485 network with Data+, Data- and Ground. More importantly, application software previously written for full-duplex RS-232 environments can be maintained without modification.

2.3.4 RS-232/422/485 Selection

COM3 and COM4 support 9-wire RS-232, RS-422 and RS-485 interfaces. The system detects RS-422 or RS-485 signals automatically in RS-422/485 mode.

To select between RS-422/485 and RS-232 for COM3, adjust JP4. To select between RS-422/485 and RS-232 for COM4, adjust JP5.

You can refer to figures below to set the JP4 and JP5.

Note: Please refer to Appendix A.2 Figure A.4 and A.5 for location of JP4 and JP5 location

Jumper setting for RS-422/485 interface: (Default setting).

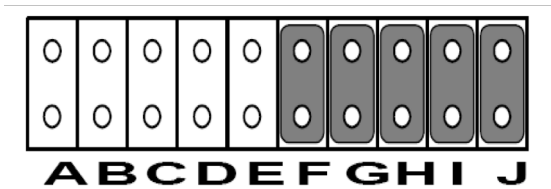

Figure 2.2: RS-422/485 Jumper Setting

Jumper setting for RS-232 interface:

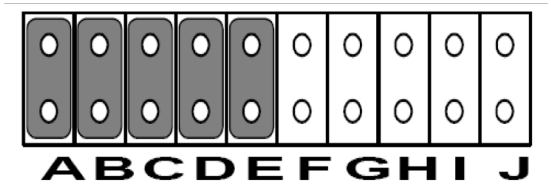
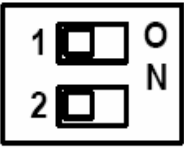
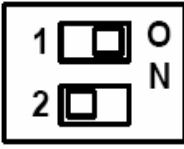
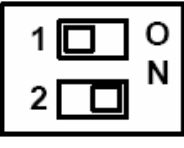
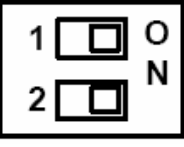

Figure 2.3: RS-232 Jumper Setting

2.3.5 RS-485 Auto Flow/RS-422 Master/Slave Selection

You can set the “Auto Flow Control” mode of RS-485 or “Master/Slave” mode of RS-422 by using the SW2 DIP switch for each RS-422/485 port. (Refer to Figure A.4 and A.5 for location of SW2).

In RS-485, if the switch is set to “Auto”, the driver automatically senses the direction of the data flow and switches the direction of transmission. Then no handshaking is necessary. In RS-422, if DIP switch is set to “On”, the driver is always enabled, and always in high or low status.

Table 2.1: Auto Flow Control and RS-422 Slave/Master Selection		
SW2 DIP Switch Setting	COM Port	Mode Selections
	COM3	RS-422: Slave mode
		RS-485: Auto flow control
	COM4	RS-422: Slave mode
		RS-485: Auto flow control
	COM3	RS-422: Master mode
		RS-485: N/A
	COM4	RS-422: Slave mode
		RS-485: Auto flow control
	COM3	RS-422: Slave mode
		RS-485: Auto flow control
	COM4	RS-422: Master mode
		RS-485: N/A
	COM3	RS-422: Master mode
		RS-485: N/A
	COM4	RS-422: Master mode
		RS-485: N/A

2.3.6 IRQ, I/O Address and Transmission Rate Setting

The IRQ and I/O address range of COM3 and COM4 are listed below:

- **COM3:** 3E8H, IRQ10 (Independent IRQ), IRQ10 (Share IRQ)
- **COM4:** 2E8H, IRQ5 (Independent IRQ), IRQ10 (Share IRQ)
- **Vector address for share IRQ:** 1D0H

You can set “Share IRQ” or “Independent IRQ” by the first switch of SW3 (Refer to Table 2.2 below).

<i>Table 2.2: IRQ Setting via switch 1 at SW3</i>	
Switch 1 at SW3 setting	Function
	Share IRQ (default)
	Independent IRQ

Note: Please Refer to Figure A.4 and A.5 for location of SW3

Note: After changing the jumper, please also adjust the IRQ through the device manager software for the new settings to work properly. (Refer to UNO Serial Port Installation Guide in the CD, steps 7 ~ 10)

<i>Table 2.3: Transmission Rate Settings (Switch 2 at SW3)</i>	
Switch 2 at SW3 setting	Function
	Speed x 8*
	Speed x 1 (default)

You can adjust the transmission rate by the second switch of SW3.

* To increase the normal baud rates by eight times, (e.g. if we set the baud rate as 115.2K bps in software, then the actual hardware baud rate will be increased to 921.6K bps), set switch 2 of SW3 to “on”.

Note: Only COM3 and COM4 can adjust the transmission rate.

2.3.7 Termination Resistor (JP6)

The onboard termination resistor (120 ohm) for COM3/COM4 can be used for long distance transmission or device matching (Default Open).

		RS-422	RS-485
COM3	Close A	TX3-TR	Data+, Data-
	Close B	RX3-TR	
COM4	Close C	TX4-TR	Data+, Data-
	Close D	TX4-TR	

Close: Enable termination resistor

Note: Please refer to Figure A.4 and A.5 for location of JP6

2.4 LAN: Ethernet Connector

The UNO-3072L is equipped with a Realtek RTL8139C Ethernet LAN controller that is fully compliant with IEEE 802.3u 10/100Base-T CSMA/CD standards. The Ethernet port provides a standard RJ-45 jack on board, and LED indicators on the front side to show its Link (Green LED) and Active (Yellow LED) status.

2.5 Onboard Isolated Digital Input

The UNO-3072L has 4 isolated DI channels designated DI0~DI3.

2.5.1 Pin Assignments

The connector type of UNO-3072L is plug-in screw terminal block that enables you to connect to field I/O devices directly without additional accessories. Figure 2.5 and Table 2.4 shows its pin assignment as well as signal description.

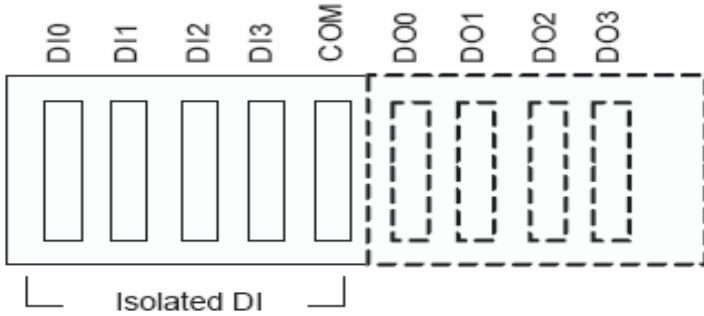

Figure 2.4: Digital Input Connector Pin Assignments

Table 2.4: Digital Input Connector Signal Description			
Signal Name	Reference	Direction	Description
DI<0...3>	COM	Input	Isolated DI signals
COM	-	-	DI, DO isolated ground

2.5.2 Isolated Inputs

Each of isolated digital input channels accepts 0 ~ 50 VDC voltage inputs, and accepts bi-directional input. The voltage range is -3 ~ 3 VDC for logic 0 (low), -50 ~ -10 VDC and 10 ~ 50 VDC for logic 1 (high). It means that you can apply positive or negative voltage to an isolated input pin (V_{in}). All channels share one common pin (COM). Figure 2.6 shows how to connect an external input source to one of the UNO-3072L isolated input channels.

Please note that DI0 and DI2 may be configured as gate control pins of Counter 0 and Counter 1; While DI1 and DI3 may be configured as input pins of Counter 0 and Counter 1. Please refer to section 2.7 for details.

Note: Please refer to Appendix A.3 Table A.6 for command of DI

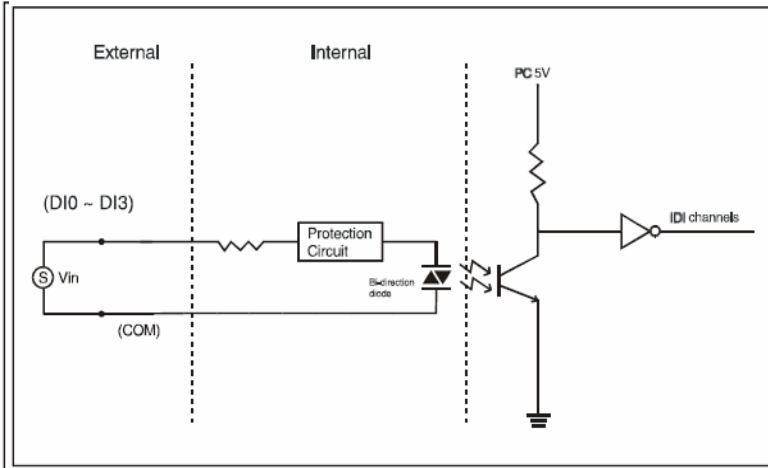

Figure 2.5: Isolated Digital Input Connection

2.5.3 Interrupt Function of the DI Signals

DI0 and DI1 can be used to generate hardware interrupts. A user can setup the configuration of interrupts by programming the interrupt control register.

The channels are connected to the interrupt circuitry. Users can disable/enable interrupt function, select trigger type or latch the port data by setting the Interrupt Control Register of the UNO-3072L (refer to section 2.5.5 below). When the interrupt request signals occur, then the software will service these interrupt requests by ISR (Interrupt Service Routine). The multiple interrupt sources provide the card with more capability and flexibility.

2.5.4 IRQ Level

The IRQ level is by default set by the system BIOS. IRQ 7 is reserved for DI interrupt and counter interrupt.

2.5.5 Interrupt Control Register

Table 2.5: Interrupt Control Register Bit Map

Base Address		7	6	5	4	3	2	1	0
202H	R/W	Interrupt Enable Control/Status Register							
								DI1EN	DI0EN
203H	R/W	Interrupt Triggering Edge Control/Status Register							
								DI1TE	DI0TE
207H	R/W	Interrupt Flag/Clear Register							
								DI1F	DI0F

The Interrupt Control Register controls the function and status of each interrupt signal source. Table 2.5 shows the bit map of the Interrupt Control Register. The register is readable/writeable register. While being written, it is used as a control register; and while being read, it is used as a status register.

DI0EN & DI1EN: DI0 & DI1 Interrupt disable/enable control bit

DI0TE & DI1TE: DI0 & DI1 Interrupt triggering edge control bit

DI0F & DI1F: DI0 & DI1 interrupt flag bit

2.5.6 Interrupt Enable Control Function

Table 2.6: Interrupt Disable/Enable Control Bit Values

DI0EN & DI1EN	Interrupt Disable/Enable Control
0	Disable
1	Enable

The user can choose to enable or disable the interrupt function by writing its corresponding value to the interrupt disable/enable control bit in the interrupt control register, as shown in Table 2.6.

2.5.7 Interrupt Triggering Edge Control

The interrupt can be triggered by a rising edge or a falling edge of the interrupt signal, as determined by the value in the interrupt triggering edge control bit in the interrupt control register, as shown in Table 2.7.

Table 2.7: Interrupt Triggering Edge Control Bit Values

DI0TE & DI1TE	Triggering edge of interrupt signal
0	Falling edge trigger
1	Rising edge trigger

2.5.8 Interrupt Flag Bit

The interrupt flag bit is a flag indicating the status of an interrupt. It is a readable/writable bit. To find the status of the interrupt, you have to read the bit value. To clear the interrupt, you have to write “1” to this bit. This bit must first be cleared to service the next coming interrupt.

Table 2.8: Interrupt Flag Bit Values

DI0F & DI1F		Interrupt Status
Read	0	No interrupt
	1	Interrupt occur
Write	0	Don't care
	1	Clear interrupt

Note: UNO-3072L provides built-in examples to show how to deliver digital input functionality. Refer to console mode examples in C:\Program Files\Advantech\UNO\UNO_IsaDIO\Examples\Console. (Please install DI/O driver from the UNO CD to use these examples)

2.6 Onboard Isolated Digital Output

The UNO-3072L has 4 isolated DO channels designated DO0 ~ DO3.

2.6.1 Pin Assignments

The connector type of UNO-3072L is plug-in screw terminal block that enables you to connect to field I/O devices directly without additional accessories. Figure 2.7 and Table 2.9 show its pin assignment as well as signal description.

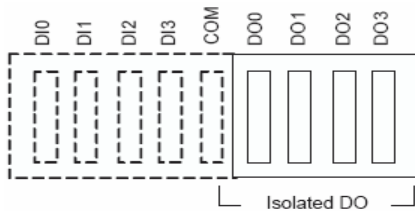

Figure 2.6: Digital Output Connector Pin Assignments

Table 2.9: Digital Output Connector Signal Description			
Signal Name	Reference	Direction	Description
DO<0...3>	COM	Output	Isolated DO signals
COM	-	-	DI, DO isolated ground

2.6.2 Power On Configuration

Default configuration after power on or hardware reset is to set all the isolated digital output channels to open status (the current of the load can't be sink) so that users need not worry about damaging external devices during system startup or reset. When the system is hot reset, then the status of isolated digital output channels are selected by jumper JP7. Table 2.10 shows the configuration of jumper JP7.

Note: Please refer to Figure A.4 and A.5 for location of JP7

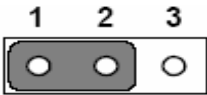
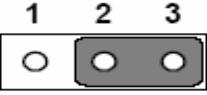
Table 2.10: Digital Output Power On Configuration	
JP7	Power on configuration after hot reset
	Reset all digital output (default configuration)
	Keep last status after hot reset

2.6.3 Isolated Outputs

Each of isolated output channels comes equipped with a Darlington transistor. All output channels share common emitters.

Please note that if an external voltage (5 ~ 40 VDC) is applied to an isolated output channel while it is being used as an output channel, the current will flow from the external voltage source to the UNO-3072L. Please take care that the current through each DO pin not exceed 200 mA. Figure 2.8 below shows how to connect an external output load to the UNO-3072L isolated outputs.

Please note that DO2 and DO3 may be configured as output pins of Counter 0 and Counter 1 (please refer to section 2.7 for more details)

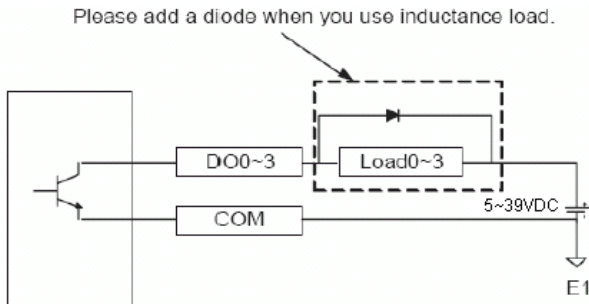
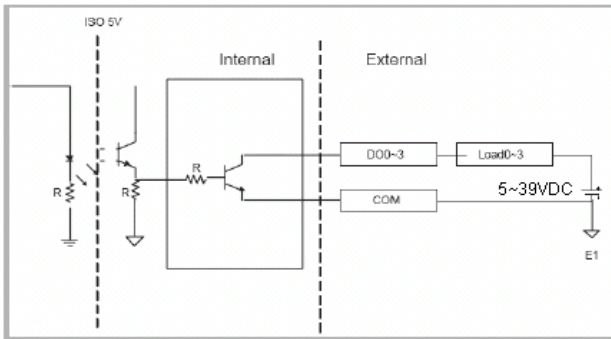

Figure 2.7: Isolated Digital Output Connection

Note: Please refer to Appendix A.3 Table A.6 for command of DO

Note: UNO-3072L provides built-in examples to show how to deliver digital output functionality. Refer to console mode examples in C:\Program Files\Advantech\UNO\UNO_IsaDIO\Examples\Console. (Please install DI/O driver from the UNO CD to use these examples)

2.7 Onboard Isolated Counter/Timer

The UNO-3072L uses one 82C54 programmable timer/counter chip that includes three independent 16-bit down counters: counter 0, counter 1 and counter 2. Counter 0 and counter 1 are for users, and counter 2 is specified for the system and can't be used by user. Each counter has clock input, gate input and pulse output. They can be programmed to count from 2 up to 65535 or cascaded into one 32-bit counter.

The UNO-3072L has two isolated counter input channels designated DI1 and DI3 with two isolated output channels designated DO2 and DO3. Therefore, you can set each counter of 82C54 as counter function or timer function.

2.7.1 Counter/Timer Control Register

The Counter/Timer Control Register controls the function and status of each counter/timer signal source. Table 2.11 shows the bit map of the Counter/Timer Control Register. The register is readable/writable register. While being written, it is used as a control register; and while being read, it is used as a status register.

Table 2.11: Counter/Timer Control Register Bit Map

Base Address		7	6	5	4	3	2	1	0
207H	R/W	Interrupt Flag/Clear Register							
						CTR1F	CTR0F		
208H	R/W	82C54 Chip Counter0 Register							
209H	R/W	82C54 Chip Counter1 Register							
20BH	R/W	82C54 Chip Control Register							

Table 2.11: Counter/Timer Control Register Bit Map

20CH	R/W	Counter0 Start Control / Output Status Register							
					CTR0 Out				CTR0 Gate
20DH	R/W	Counter1 Start Control / Output Status Register							
					CTR1 Out				CTR1 Gate
20EH	R/W	Counter0 Setting Register							
						CTR0 IntSet	CTR0 OutSet	CTR0 GateSet	CTR0 CLKSet
20FH	R/W	Counter1 Setting Register							
			CTR32 Set	S1	S0	CTR1 IntSet	CTR1 OutSet	CTR1 GateSet	CTR1 CLKSet

CTR0F/CTR1F: (Counter 0/1) interrupt flag bit

CTR0Gate/CTR1Gate: (Counter 0/1) gate control bit

CTR0Out /CTR1Out: (Counter 0/1) output status bit

CTR0CLKSet /CTR1CLKSet: (Counter 0/1) clock source control bit

CTR0GateSet/CTR1GateSet: (Counter 0/1) gate source control bit

CTR0OutSet/CTR1OutSet: (Counter 0/1) output destination control bit

CTR0IntSet/CTR1IntSet: (Counter 0/1) interrupt control bit

S0/S1: (Counter 0/1) internal clock control bit

CTR32Set: Cascaded 32-bit counter control bit

2.7.2 Counter 0 Function Block

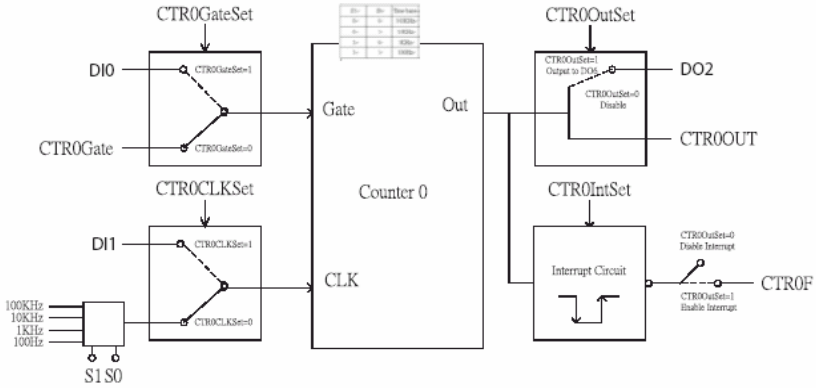

Figure 2.8: Counter 0 Function Block

2.7.3 Counter 1 Function Block

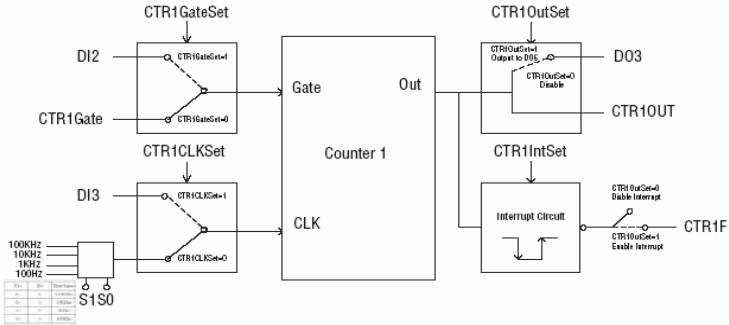

Figure 2.9: Counter 1 Function Block

2.7.4 32-bit Counter Function Block (CTR32Set=1)

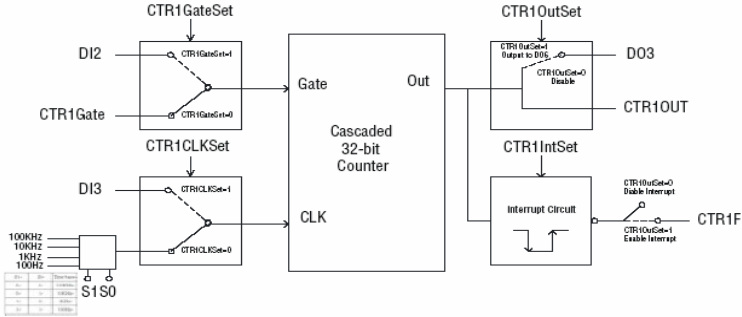

Figure 2.10: 32-bit Counter Function Block

2.7.5 Counter Clock Source

There are two clock sources available for the user counters by setting counter clock control bits - CTR0CLKSet and CTR1CLKSet.

Table 2.12: Counter Clock Source Control Bit

CTR0CLKSet	0	Internal clock (default)
	1	External clock from digital input 1 (DI1) channel
CTR1CLKSet	0	Internal clock (default)
	1	External clock from digital input 3 (DI3) channel

2.7.6 Counter Internal Clock

There are four frequency options to choose according to applications, and it's set by internal clock control bits - S0 and S1.

Table 2.13: Counter Internal Clock Control Bit

S1	S0	Time base
0	0	100 KHz (default)
0	1	10 KHz
1	0	1 KHz
1	1	100 Hz

2.7.7 Counter Gate Source

The gate sources you select determine what kind of gate input signal to enable your counter/timer when receiving clock input. There are two gate sources available for the user counters by setting gate source control bits - CTR0GateSet and CTR1GateSet.

Table 2.14: Counter Gate Source Control Bit

CTR0GateSet	0	Gate source from “CTR0Gate” control bit (Default)
	1	Gate source from digital input 0 (DI0) channel
CTR1GateSet	0	Gate source from “CTR1Gate” control bit (Default)
	1	Gate source from digital input 2 (DI2) channel

2.7.8 Counter Output Destination

You can choose the output destination of counter 0 and counter 1 by setting “Output Destination control bits”- CTR0OutSet and CTR1OutSet.

Table 2.15: Counter Output Destination Control Bit

CTR0OutSet	0	Output destination to “CTR0Out” status bit (Default)
	1	Output destination to “CTR0Out” status bit and digital output 2 (DO2) channel
CTR1OutSet	0	Output destination to “CTR1Out” status bit. (Default)
	1	Output destination to “CTR1Out” status bit and digital output 3 (DO3) channel

2.7.9 Counter Interrupt Flag

The interrupt flag bit is a flag indicating the status of an interrupt. It is a readable/writable bit. To find the status of the interrupt, you have to read the bit value; to clear the interrupt, you have to write “1” to this bit. This bit must first be cleared to service the next coming interrupt. Besides, you can choose if counter 0 or counter 1 generate interrupt signal by configuring “CTR0IntSet” and “CTR1IntSet” control bit.

Table 2.16: Counter Interrupt Flag Control Bit

CTR0F, CTR1F		Counter Interrupt Status
Read	0	No interrupt
	1	Interrupt occur
Write	0	Don't care
	1	Clear interrupt
CTR0IntSet, CTR1IntSet		Counter Interrupt Control
0		Disable (Default)
1		Enable

2.7.10 Cascaded 32-bit Counter

You can also cascade counter 0 and counter 1 together as one 32-bit counter/timer, and it's configured by control bit - CTR32Set.

Table 2.17: 32-bit Counter Control Bit

0	Disable (Default)
1	Cascade counter 0 and counter 1 into one 32-bit counter

Note: UNO-3072L provides built-in examples to show how to deliver counter functionality. Refer to console mode examples in C:\Program Files\Advantech\UNO\UNO_IsaDIO\Examples\Console. (Please install DI/O driver from the UNO CD to use these examples)

2.8 Power Input

UNO-3072L comes with a Phoenix connector that carries 16~36 VDC external power input, and features reversed wiring protection. Therefore, it will not cause any damage to the system by reversed wiring of ground line and power line. (Please refer to Figure 2.12 for location of power input)

The UNO-3072L supports two individual power inputs (P1/P2). (Please refer to Appendix A.7 for wiring of P1 and P2)

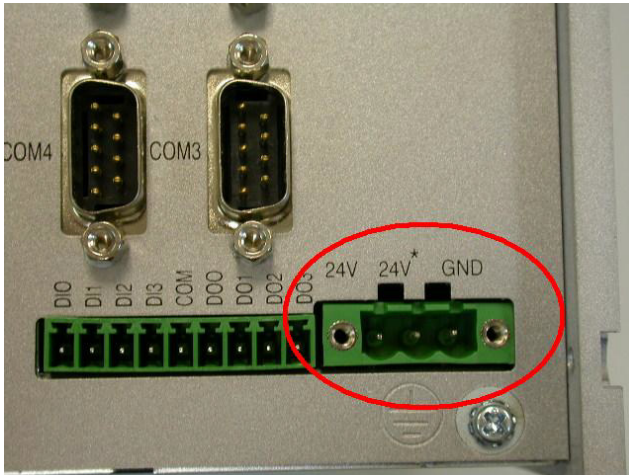

Figure 2.11: Location of Power P1 and P2

You can see the LED indicators to monitor power input situation. (Please refer to Figure 2.13 for location of LED). If the voltage of power input $P1 > 15$ VDC, the P1 LED indicator will be enable (means the first power input is used). It is the same for P2 LED indicator (to show if the voltage of power input $P2 > 15$ VDC). When any voltage of P1 and P2 < 15 VDC, the Fault LED will be enable. It means that you don't use redundancy power input. When you have two power inputs, the system will use the power inputs with higher voltage.

Note: UNO-3072L provides built-in examples to show how to monitor power input status. Refer to console mode examples in C:\Program

*Files\Advantech\UNO\UNO_IsaDIO\Examples\Console.
 (Please install DI/O driver from the UNO CD to use these examples)*

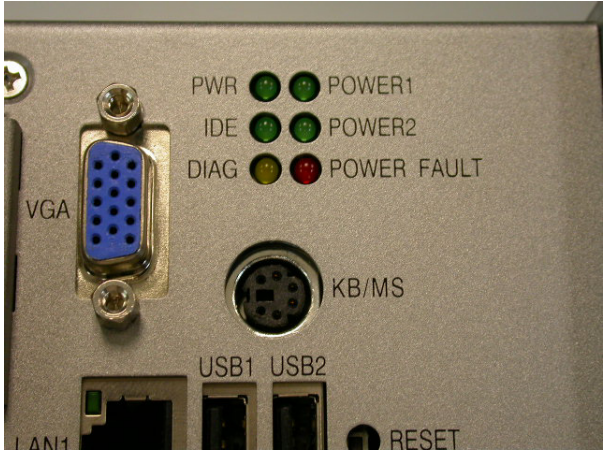

Figure 2.12: LED Indicators Location to Monitor Power Input Situation

Table 2.18: Power Register Bit Map

218H	R	Power Register						
							PWR	P2

- PWR =0, Power fail
 =1, Power normal
- P1 (24V) =0, Power input 1 fail
 =1, Power input 1 normal
- P2 (24V*) =0, Power input 2 fail
 =1, Power input 2 normal

2.9 LED and Buzzer for System Diagnosis

In a “headless application” (an application without a monitor display), it is always difficult to know the system status. Another PC may be needed to monitor a headless device's status via RS-232 or Ethernet. In order to solve this problem, UNO-3072L offers a programmable LED indicator (Figure 2.14) and buzzer. They can be programmed to show a systems status by LED indicator flickering and buzzer alarm.

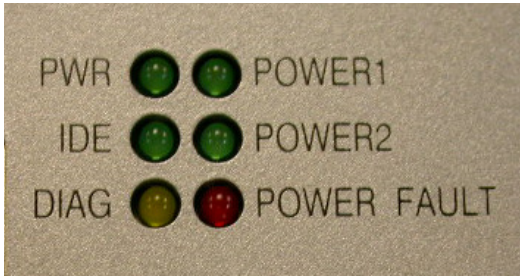

Figure 2.13: LED Indicator Location for System Diagnosis

Table 2.19: LED and Buzzer Control Register Bit Map

210H	R/W	DIAG LED Register								
								LEDS1	LEDS0	LEDEn
211H	R/W	Buzzer Register								
								SPKS1	SPKS0	SPKEen

LEDEn: =0, DIAG LED disable
 =1, DIAG LED enable

LEDS0 and LED S1: LED flickering speed setting bit (refer to Table 2.20)

SPKEen: =0, Speaker disable
 =1, Speaker enable

SPKS0 & SPKS1: Buzzer alarming setting bit (refer to Table 2.21)

Note: UNO-3072L provides built-in examples to show how to configure DIAG LED and Buzzer. Refer to console mode examples in C:\Program Files\Advantech\UNO\UNO_IsaDIO\Examples\Console.

(Please install DI/O driver from the UNO CD to use these examples)

Table 2.20: Programmable LED Control Bit

	LEDS1	LEDS0
Light on	0	0
Fast flicker	0	1
Normal flicker	1	0
Short flicker	1	1

Table 2.21: Programmable Buzzer Control Bit

	SPKS1	SPKS0
Beep on	0	0
Short beep	0	1
Normal beep	1	0
Long beep	1	1

2.10 PS/2 Keyboard and Mouse Connector

The UNO-3072L provides a PS/2 keyboard and PS/2 mouse connector. A 6-pin mini-DIN connector is located on the front panel. UNO-3072L comes with an adapter in the accessory package (see section 1.5) to convert from the 6-pin mini-DIN connector to two 6-pin mini-DIN connectors for PS/2 keyboard and PS/2 mouse connection. Please refer to Appendix A.8 for its pin assignments.

2.11 USB Connector

The USB connector is used for connecting any device that conforms to the USB interface. Many recent digital devices conform to this standard. The USB interface supports Plug and Play, which enables you to connect or disconnect a device whenever you want, without turning off the computer.

The UNO-3072L provides four connectors of USB interfaces. The USB interface complies with USB UHCI, Rev. 2.0 compliant. The USB interface can be disabled in the system BIOS setup. Please refer to Appendix A.9 for its pin assignments.

2.12 VGA Display Connector

The UNO-3072L provides a VGA controller (Intel 855GME GMCH ICH4 Chipset 400MHz FSB) for a high resolution VGA interface. It supports up to 1280 x 1024 @ 16bpp (60Hz).

2.13 Reset Button

Press the "Reset" button to activate the reset function.

Note: Please refer to Figure 2.12 for the location of RESET

Initial Setup

This chapter introduces how to initialize the UNO-3072L.

Sections include:

- Introduction
- Inserting a CompactFlash Card
- Chassis Grounding
- Connecting Power
- Connecting a Hard Disk
- BIOS Setup and System Assignments

Chapter 3 Initial Setup

3.1 Inserting a CompactFlash Card

UNO-3072L has one internal CompactFlash slot (CN3). It's used to install O.S and Application Program

JP2 on mainboard (refer to Figures A.4 and A.5)

Closed: CN3 CompactFlash on mainboard is the master

Open: CN3 CompactFlash on mainboard is slave

- NOTE:*
- 1. Only one CompactFlash can be set as master*
 - 2. Internal & external CompactFlash doesn't support Hot Swap*
 - 3. Needs to use " Fixed Disk Mode" CompactFlash to install OS*

Following is the procedure for the installing a CompactFlash card in the internal slot (CN3) of your UNO-3072L. Please follow these steps carefully:

1. Remove the power cord.
2. Unscrew the four screws from the top cover of UNO-3072L.
3. Remove the top cover.
4. Plug a CompactFlash card with your OS and application program into a CompactFlash card slot on mainboard.
5. Screw back the top cover with four screws.

3.2 Connecting Power

Connect the UNO-3072L to a 16 ~ 36 VDC power source. The power source can either be from a power adapter or an in-house power source.

3.3 Installing a Hard Disk

The procedure for installing a hard disk is listed below. Please follow these steps carefully.

1. Remove the power cord.
2. Unscrew the eight screws from the upper cover (as shown below)



3. Unscrew the HDD bracket from the upper cover.

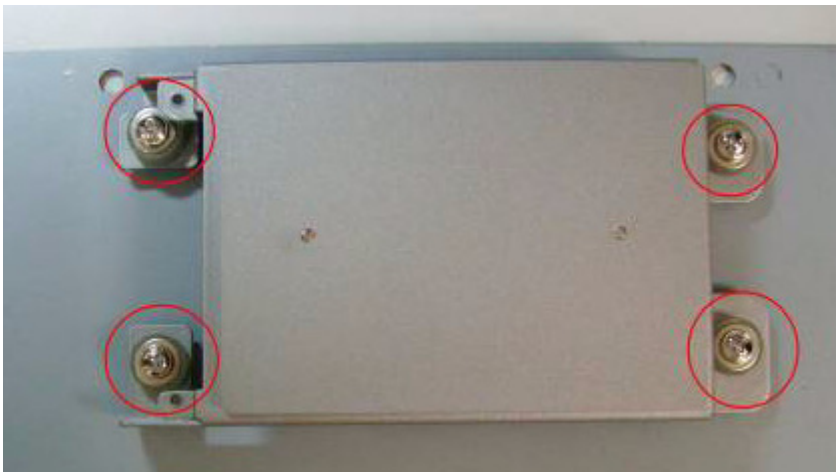

4. Install the HDD in HDD bracket and secure with the four screws, and then fix the HDD bracket on the upper cover. Please refer to pictures below.
Note: UNO product can support 2.5" IDE & SATA interface HDD, pls check the HDD interface before installation
When connecting IDE cable with 2.5" HDD, pay attention to the direction of IDE cable. (the pink line is the 1st pin of IDE cable).
5. IDE HDD Installation
Make sure the IDE cable pink line is connect with 1st pin of HDD

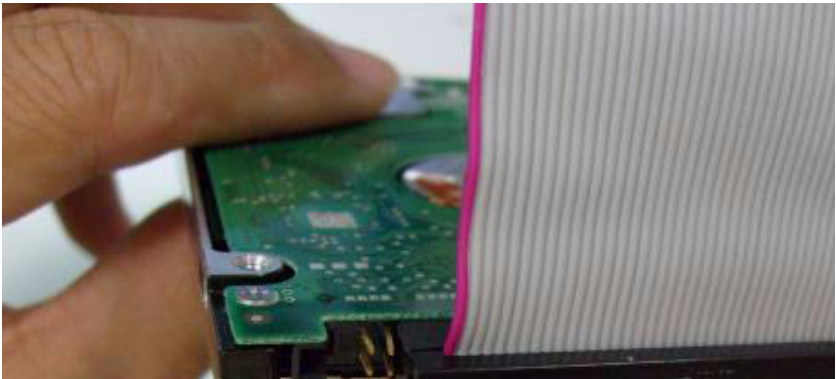

Install HDD into HDD bracket and fix the screw



Screw HDD bracket to fix on upper cover

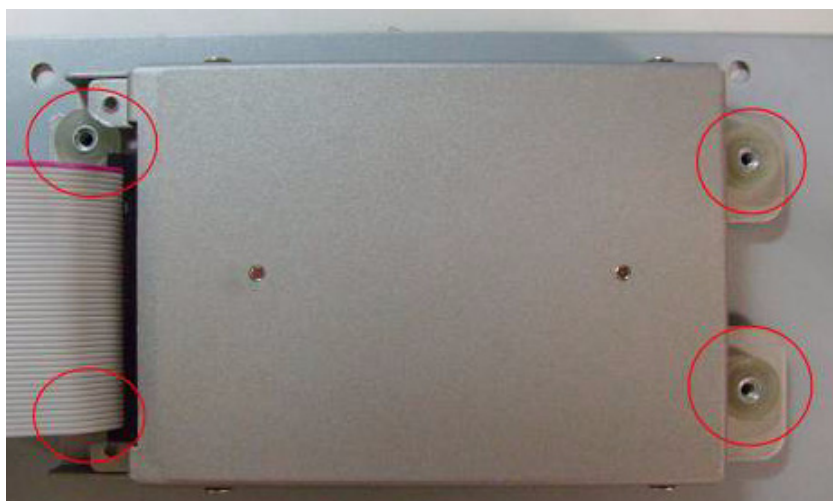

Connect IDE cable with IDE connector, please also pay attention of the direction. The correct connection way is shown below, notice the pink line must connect with 1st pin of IDE connector

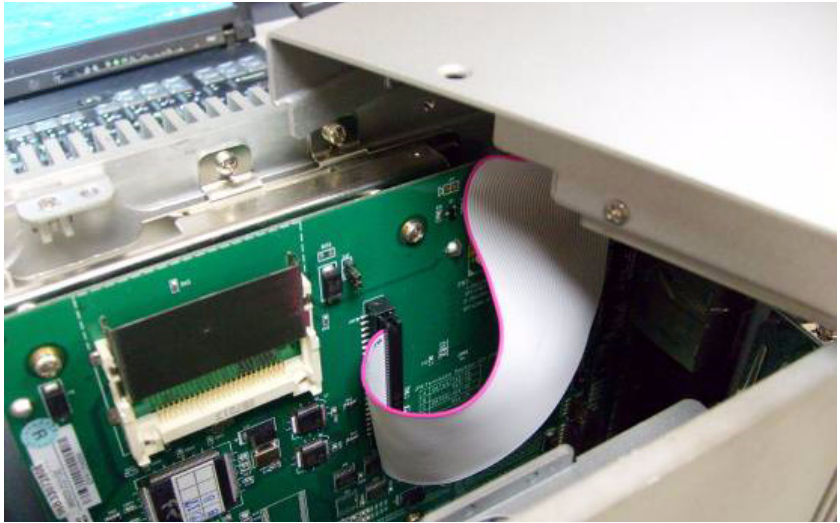

6. SATA HDD Installation (Only for UNO-3072L-C11BE & UNO-3072L-C22BE)
Install HDD into HDD bracket and fix with screw



Screw HDD bracket to fix on upper cover



Connect IDE cable with adapter board's IDE connector, please also pay attention of the direction. The correct connection way is shown below, notice the pink line must connect with 1st pin of IDE connector

Screw the adapter board on HDD bracket

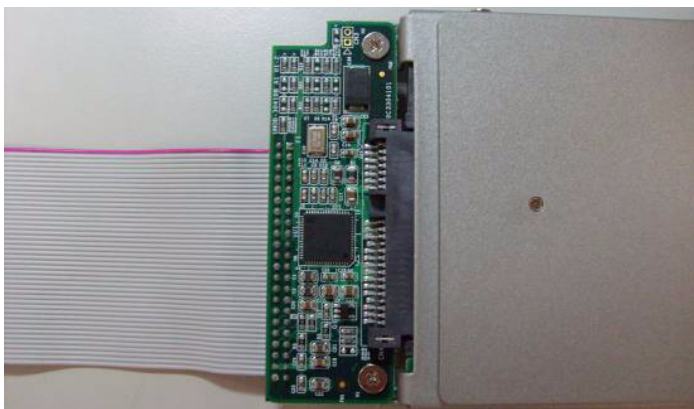
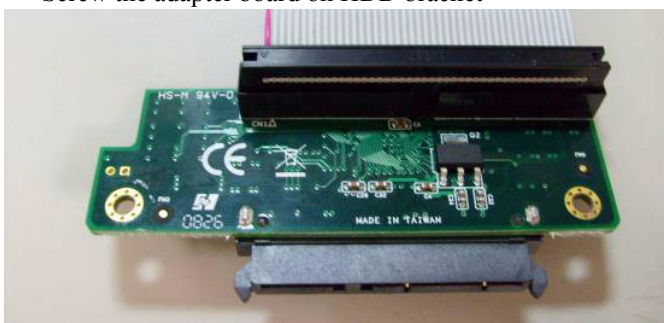

7. Connect IDE cable with IDE connector, please also pay attention of the direction. The correct connection way is shown below, notice the pink line must connect with 1st pin of IDE connector

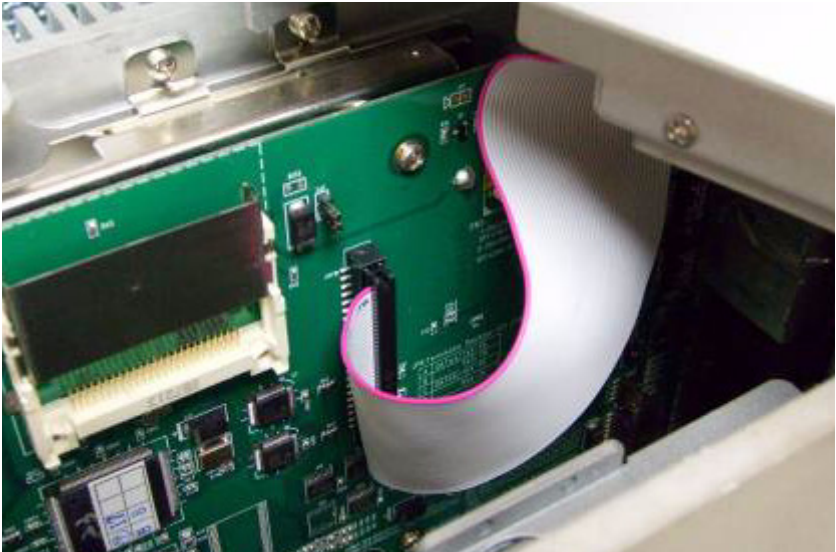

8. Re-fasten the upper cover with the eight screws.



3.4 Installing a PCI-bus Card

The procedure for installing a PCI-bus card into the UNO-3072L is listed below. Please follow these steps carefully.

1. Remove the power cord.
2. Remove the upper cover of UNO-3072L.
3. Unscrew the screw of a PCI bracket, and remove it.
4. Plug-in PCI-bus card in a PCI-slot of UNO-3072L.
5. Screw the 1st anti-vibration rubber towards the 1st PCI card until it is fixed. (Figure 3.2).

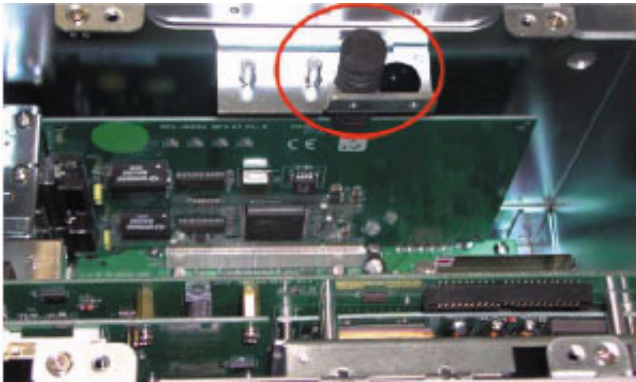

Figure 3.1: 1st Anti-Vibration Rubber

6. Install PCI extension to hold 2nd anti-vibration rubber (Figure 3.3) and screw the 2nd anti-vibration rubber towards the 2nd PCI card until it is fixed.



Figure 3.2: 2nd PCI-bus Card Installation

7. Cut off a part of the anti-vibration rubber if it is too long to fit into the box when the PCI card is fixed.

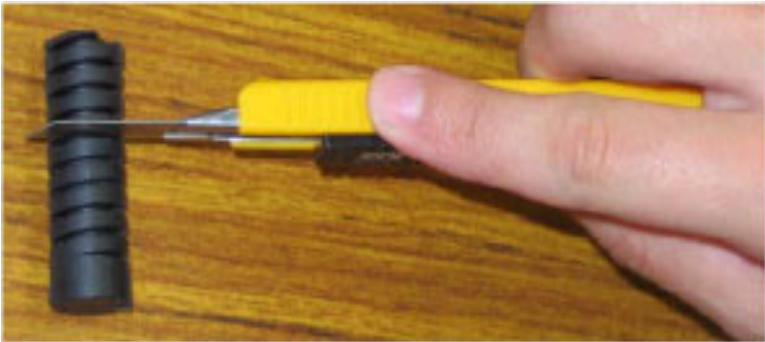

Figure 3.3: Adjust the Size of the Anti-Vibration Rubber

8. Screw back the upper cover with the four screws.

3.5 Mounting UNO-3072L

There are 3 types of mounting kits for UNO-3000 series:

- Panel mount
- Stand mount
- Wallmount

Pls refer to *UNO-3000 Series Accessories Manual*

Note: Due to thermal performance issues, Wallmount will only support specific models.

3.6 Installing Power Cable

UNO-3072L provides an internal backup power source so that it can provide power for a CD-ROM, DVD-ROM or other external devices. You can use the power cable from accessory package (see section 1.5).

Yellow	+12V
Black	GND
Black	GND
Red	+5V

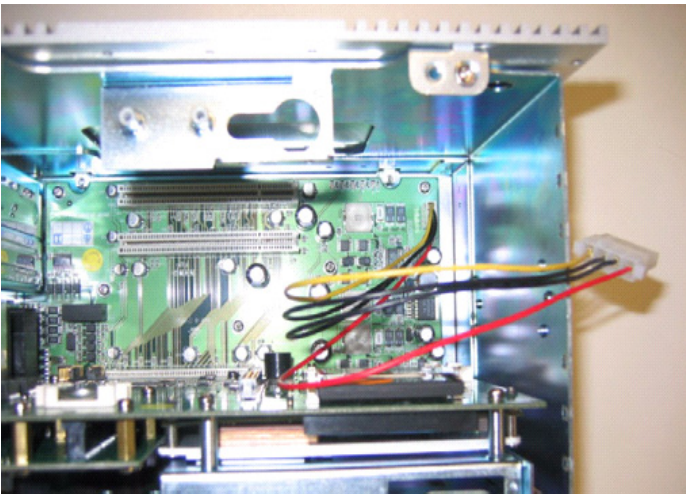

Figure 3.4: Internal Backup Power Source

3.7 UNO-3072L Mounting Caution



Figure 3.5: UNO-3072L Improper Installation (1)



Figure 3.6: UNO-3072L Improper Installation (2)



Figure 3.7: UNO-3072L Correct Installation

Note: Because the heat transfer mechanism is designed close to the right side of system, make sure not to attach the right side of the UNO chassis to the wall or ground. (shown in Figure 3.10 and 3.11) It may make the system easy to hang due to the heat transfer issue. Instead, try to allow some space on the right side of UNO chassis. This will make the system easier to transfer heat from the inside to the outside. (refer to Figure 3.12).

3.8 BIOS Setup and System Assignments

UNO-3072L adapts Advantech's SOM-4486 CPU module. Further information about the SOM-4486 CPU module can be found in user manual of SOM-4486. You can find this manual on the driver and utility CD of UNO-3072L in the accessory package. Please note that you can try to "LOAD DEFAULTS" from the BIOS Setup manual if the UNO-3072L does not work properly.

APPENDIX
A

**System Settings and
Pin Assignments**

Appendix A System Settings and Pin Assignments

A.1 System I/O Address and Interrupt Assignments

Table A.1: UNO-3072L System I/O Port

Address Range	Device
000-01F	DMA controller (slave)
020-03F	Interrupt controller 1 (master)
040-05F	8254 timer/counter
060-06F	8042 (keyboard controller)
070-07F	Real-time clock, non-maskable interrupt (NMI)
080-09F	DMA page register
0A0-0BF	Interrupt controller 2 (slave)
0C0-0DF	DMA controller (master)
0F0	Clear math co-processor
0F1	Reset math co-processor
0F8-0FF	Math co-processor
1D0	Vector address; for COM port share IRQ
1E0	Reserved
11E	Reserved
1F0-1F8	1st fixed disk
200-218	DI/O and counter
278-27F	Reserved
2E8-2EF	Serial port 4
2F8-2FF	Serial port 2
300-31F	Ethernet
360-36F	LPT2
378-37F	Parallel printer port 1 (LPT1)
380-38F	SDLC, bisynchronous 2
3A0-3AF	Bisynchronous 1
3B0-3BF	Monochrome display
3C0-3CF	Reserved
3D0-3DF	Color/graphics monitor adapter
3F0-3F7	Diskette controller
3E8-3EF	Serial port 3
3F8-3FF	Serial port 1
443	Watchdog timer

Table A.2: UNO-3072L Interrupt Assignments

Interrupt No.	Interrupt Source
IRQ 0	Interval timer
IRQ 1	Keyboard
IRQ 2	Interrupt from controller 2 (cascade)
IRQ 3	COM2
IRQ 4	COM1
IRQ 5	COM4 (Independent IRQ)
IRQ 6	Diskette controller (FDC)
IRQ 7	DI/O
IRQ 8	Real-time clock
IRQ 9	N/A
IRQ 10	COM3 (Independent IRQ)/COM3&COM4 Share IRQ
IRQ 11	Reserved for watchdog timer
IRQ 12	PS/2 mouse
IRQ 13	INT from co-processor
IRQ 14	Primary IDE
IRQ 15	Secondary IDE

A.2 Board Connectors and Jumpers

There are several connectors and jumpers on the UNO-3072Lboard. The following sections tell you how to configure the UNO-3072Lhardware setting. Figures A.1 to A.7 show the location of UNO-3072Lconnectors and jumpers.

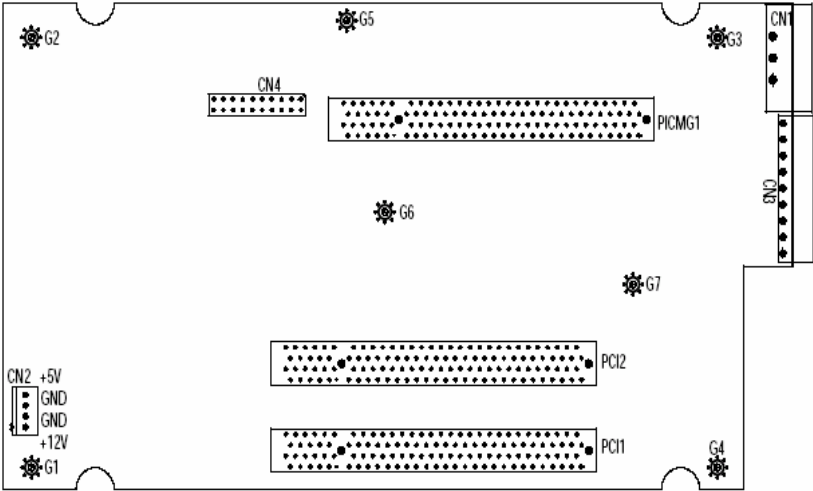

Figure A.1: Backplane Connector and Jumper Locations

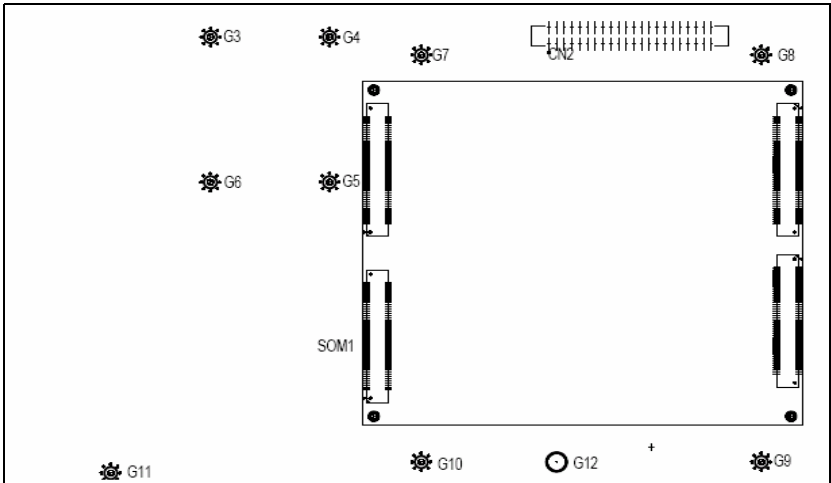

Figure A.2: Mainboard Connector and Jumper Locations (Backside)

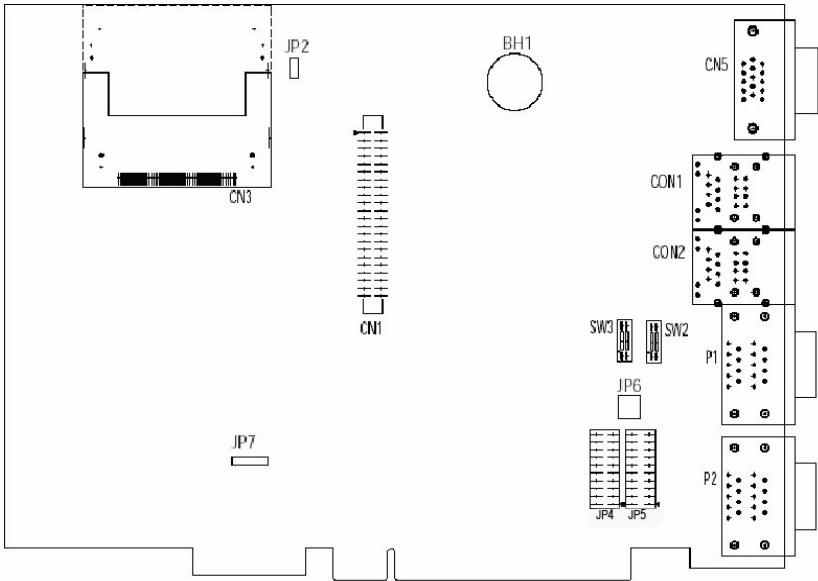

Figure A.3: Mainboard Connector and Jumper Locations (Frontside)

Table A.3: Connector and Jumper Descriptions		
Location	Label	Function
Backplane	CN1	Phoenix power connector
	CN2	Internal power source (Reserved)
	CN3	DIO connector
	CN4	Communication slot for UNO-3072L main board
	PICMG1	Communication slot for UNO-3072L main board
	PCI1	PCI slot 1
	PCI2	PCI slot 2

Table A.4: Connector and Jumper Descriptions

Mainboard	CN1	Primary IDE connector
	CN2	Secondary IDE connector
	CN3	CompactFlash slot 1
	CN5	VGA DB15 display connector
	P1	COM1~COM2 Standard RS-232 port
	P2	COM3~COM4 RS-232/422/485 port
	CON1	Ethernet1/USB1/USB2 ports
	CON2	Ethernet2/USB3/USB4 ports
	BH1	Lithium battery for BIOS
	SW2	COM3/COM4 RS-422 master/slave selection
	SW3	Share IRQ/Independent IRQ selection and Speed selection
	JP2	CompactFlash 1 master/slave selection
	JP4	COM4 RS-232/422/485 selection
	JP5	COM3 RS-232/422/485 selection
	JP6	COM3/COM4 terminator resistor
JP7	Digital output latch/non-latch	

A.3 UNO-3072L Control Register

Table A.5: UNO-3072L Control Register

Base Address		7	6	5	4	3	2	1	0
200H	R	Isolated Digital Input Status Register							
		DI7	DI6	DI5	DI4	DI3	DI2	DI1	DI0
201H	R/W	Isolated Digital Output Control/Status Register							
		DO7	DO6	DO5	DO4	DO3	DO2	DO1	DO0
202H	R/W	Interrupt Enable Control/Status Register							
								DI1EN	DI0EN
203H	R/W	Interrupt Triggering Edge Control/Status Register							
								DI1TE	DI0TE
207H	R/W	Interrupt Flag/Clear Register							
						CTR1F	CTR0F	DI1F	DI0F
208H	R/W	82C54 Chip Counter0 Register*							
209H	R/W	82C54 Chip Counter1 Register*							
20BH	R/W	82C54 Chip Control Register*							
20CH	R/W	Counter0 Start Control / Output Status Register							
					CTR0 Out				CTR0 Gate
20DH	R/W	Counter1 Start Control / Output Status Register							
					CTR1 Out				CTR1 Gate
20EH	R/W	Counter0 Setting Register							
						CTR0 IntSet	CTR0 OutSet	CTR0 GateSet	CTR0 CLKSet
20FH	R/W	Counter1 Setting Register							
			CTR 32Set	S1	S0	CTR1 IntSet	CTR1 OutSet	CTR1 GateSet	CTR1 CLKSet
210H	R/W	DIAG LED Control Register							
							LEDS1	LEDS0	LEDEn
211H	R/W	Buzzer Control Register							
							SPKS1	SPKS0	SPKEen
218H	R	Power Register							
							PWR	P2	P1

* Refer to 82c54 manual

A.4 RS-232 Standard Serial Port (COM1~COM2)

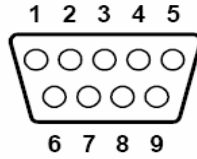

Table A.6: RS-232 Standard Serial Port Pin Assignments

Pin	RS-232 Signal Name
1	DCD
2	RxD
3	TxD
4	DTR
5	GND
6	DSR
7	RTS
8	CTS
9	RI

A.5 RS-232/422/485 Serial Port (COM3~COM4)

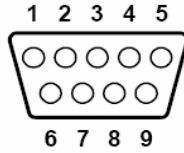

Table A.7: RS-232/422/485 Serial Port Pin Assignments

Pin	RS-232	RS-422	RS-485
1	DCD	Tx-	DATA-
2	RxD	Tx+	DATA+
3	TxD	Rx+	NC
4	DTR	Rx-	NC
5	GND	GND	GND
6	DSR	NC	NC
7	RTS	NC	NC
8	CTS	NC	NC
9	RI	NC	NC

A.6 Ethernet RJ-45 Connector (LAN1~LAN2)

Table A.8: Ethernet RJ-45 Connector Pin Assignments

Pin	10/100Base-T Signal Name
1	XMT+
2	XMT-
3	RCV+
4	NC
5	NC
6	RCV-
7	NC
8	NC

A.7 Power Screw Terminal (PWR)

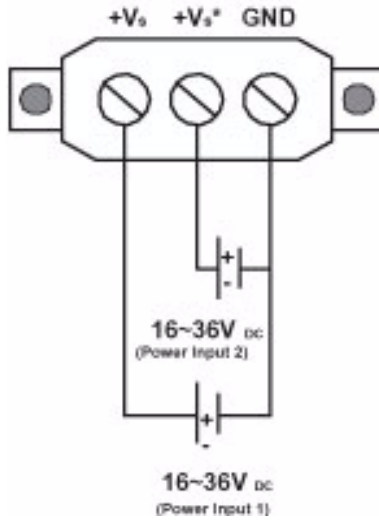

Figure A.8: Power Connector Pin Assignments

Table A.9: Power Connector Pin Assignments

Pin	Signal Name
+Vs	Power input 1; Range: 16~36 VDC (P1)
+Vs*	Power input 2; Range: 16~36 VDC (P2)
GND	Ground

A.8 PS/2 Keyboard and Mouse Connector

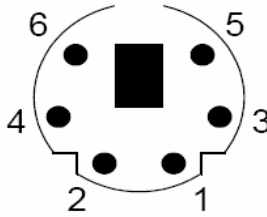

Table A.10: Keyboard and Mouse Connector Pin Assignments

Pin	Signal Name
1	KB DATA
2	MS DATA
3	GND
4	VCC
5	KB Clock
6	MS Clock

A.9 USB Connector (USB1~USB4)

Table A.11: USB Connector Pin Assignments

Pin	Signal Name	Cable Color
1	VCC	Red
2	DATA+	White
3	DATA-	Green
4	GND	Black

A.10 VGA Display Connector

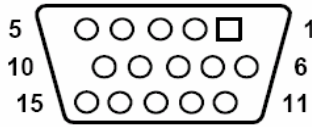

Table A.12: VGA Adaptor Cable Pin Assignmen

Pin	Signal Name
1	Red
2	Green
3	Blue
4	NC
5	GND
6	GND
7	GND
8	GND
9	NC
10	GND
11	NC
12	NC
13	H-SYNC
14	V-SYNC
15	NC

APPENDIX

B

Programming the Watchdog Timer

Appendix B Programming the Watchdog Timer

B.1 Watchdog programming

Below is a sample of programming code for controlling the Watchdog Timer function.

Enter the extended function mode, interruptible double-write

```
MOV DX,2EH
MOV AL,87H
OUT DX,AL
OUT DX,AL
```

Configured logical device 8, configuration register CRF6

```
MOV DX,2EH
MOV AL,2BH
OUT DX,AL
MOV DX,2FH
IN AL,DX
AND AL,0EFH;Setbit 4=0 Pin 89=WDTO
OUT DX,AL
MOV DX,2EH
MOV AL,07H; point to Logical Device Number Reg.
OUT DX,AL
MOV DX,2FH
MOV AL,08H; select logical device 8
OUT DX,AL;
MOV DX,2EH
MOV AL,30H;Set watch dog activate or inactivate
```

```

OUT DX,AL
MOV DX,2FH
MOV AL,01H; 01:activate 00:inactivate
OUT DX,AL;
MOV DX,2EH
MOV AL,F5H; Setting counter unit is second
OUT DX,AL
MOV DX,2FH
MOV AL,00H
OUT DX,AL;
MOV DX,2EH
MOV AL,F6H
OUT DX,AL
MOV DX,2FH
MOV AL,05H; Set 5 seconds
OUT DX,AL
;-----
; Exit extended function mode |
;-----
MOV DX,2EH
MOV AL,AAH
OUT DX,AL

```

