

INTRODUCTION

- ▶ Energy Sistem® thanks you for buying your new Energy™ Docking 100, we wish you enjoy using it.

Dock for iPod/iPhone with clock radio function, great choice for your room. Charge your iPod/iPhone and play your favourite music at the same time. Store 20 FM presets, use the line-in to hear any other audio device.

We recommend you to read this user manual in order to enjoy the product in a safe way and with the best results.

CARE AND MAINTENANCE

- ▶ Do not expose your Energy™ Docking 100 to shock, dust, humidity or high temperatures.
- ▶ Do not use cleaners or scouring agents.
- ▶ Keep the unit clean and dust with a soft, dry cloth.
- ▶ Do not disassemble the device. Any repairs must be done by qualified service personnel authorised only by Energy Sistem Soyntec SA
- ▶ Keep your Energy™ Docking 100 away from water or moisture, it can be harmful to both speakers or amplifier device.

TECHNICAL SPECIFICATIONS

- ▶ 2.0 sound system with real power of 2x2W.
- ▶ LED display.
- ▶ PLL FM radio with 20 presets.
- ▶ 2 independent alarms (iPhone/iPod, FM radio or buzzer).
- ▶ Snooze mode (9 minutes).
- ▶ Output power (6 ohms): 2W+2W
- ▶ AC/DC 100 - 240V / 50-60Hz.
- ▶ Max. distortion: <10%
- ▶ Power supply input: DC 5V.
- ▶ FM sensitivity: <20dB
- ▶ S/N Ratio: 50 dB.

PACKAGE CONTENT

- ▶ Energy™ Docking 100
- ▶ User manual.
- ▶ AC/DC adapter.

GENERAL PRESENTATION

- ▶ Top view

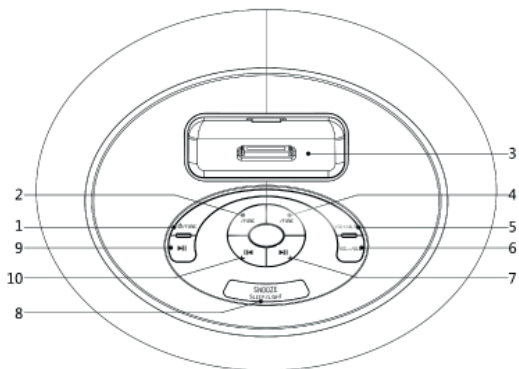

1. ϕ /FUNC: Click for power on/ Click for functions switch over.
2. MEM/SET: Clock setting and presetes.
3. 30 pins connector for iPhone/iPod
4. MEM+: Presets selection.
5. VOL+/ALI: Volume up and alarm clock 1 setting.
6. VOL-/AL2: Volume down and alarm clock 2 setting.
7. $\blacktriangleright\blacktriangleright$: Next song or radio station.
8. SNOOZE/SLEEP/LIGHT: Snooze of alarm clock/ sleep time selection/ LED brightness adjust.
9. $\blacktriangleright\text{II}$: Play/Pause
10. $\blacktriangleleft\blacktriangleleft$: Last song or radio station.

- ▶ Rare view / connections.

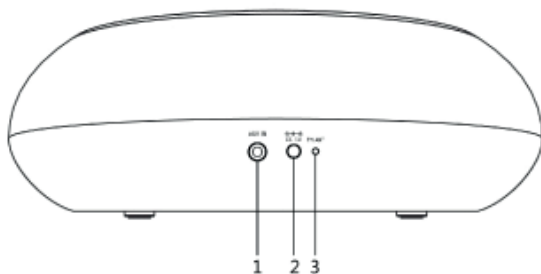

1. **AUX IN:** External audio input socket(3.5mm socket).
2. **DC 5V:** DC 5V power input socket.
3. **FM ANT:** FM antenna.

MAIN FEATURES

- ▶ Enjoy all your favourite songs in your Iphone/Ipod you just have to plug it on the dock. Use it as clock radio and choose the best option for you (Iphone/iPod, FM radio or buzzer). PLL FM radio tuner and line-in to connect any other audio device.

Cuenta con sintonizador digital de FM y entrada auxiliar (line-in) para conectar dispositivos de audio.

POWERING UP

- ▶ Place the Energy™ Docking IOO on the desired place, connect the AC/CD adapter to the wall power connection. Finally insert the cable into the supply socket.

ON / OFF AND SWITCHING FUNCTIONS.

- ▶ Once that you had connected your Energy™ Docking IOO to the main power, press ϕ /FUNC to power on; then the display will show "IPOD", press again and you will select the FM function, press again and you will see "AU" that is line-in function, pressing again you will return to the IPOD.

If you want to turn off the device you only have to keep pressed the ϕ /FUNC during three seconds.

PLAYING YOUR IPOD/IPHONE.

- ▶ Your iPod/iPhone have to be connected to the dock, press the **⏏/FUNC** button and you can see the word "IPOD" in the display, at that time your iPod/iPhone is now sync with your Energy™ Docking 100.

To browse into your play list you have to use the **⏮** and **⏭** buttons.

SETTING CLOCK

- ▶ After the Energy™ Docking 100 is plugged into a mains power, the display will show the "12:00". To set the current clock the unit has to be in standby mode.
 1. Press **MEM/SET** button, the digits for the display will blink.
 2. Use the **⏮** and **⏭** buttons repeatedly until the correct hour is set, to set the minutes press **MEM/SET** again and use **⏮** and **⏭** until the correct minutes are set. Finally press **MEM/SET** to confirm.
 3. Also, you can connect your iPod/iPhone to the dock and the time will be sync at the same time.

CHARGING YOUR IPOD/IPHONE.

- ▶ You can charge your iPod/iPhone using your Energy™ Docking 100, you only have to plug it to the dock.

FM RADIO

- ▶ Press the button **/FUNC** to select the FM option and use the **⏮** and **⏭** to turn your favourite radio station.

Store up to 20 presets. If you want to save the radio station in the presets you have to keep pressed **MEM/SET**, you will see "PO1" in the display; use **⏮** and **⏭** to select positions for station memory that you want and press **MEM/SET** to confirm. To find the pre-stored memory use the **MEM+** button. Keep pressed the **MEM+** to do a quick search over the presets.

LINE-IN / AUX (AUX AUDIO INPUTS)

- ▶ Use the Energy™ Docking 100 as a speaker; you only have to connect it to any audio device.

AUX-IN

- ▶ To use playback line input (LINE-IN), connect one end of the audio cable (not included) to the 3.5mm input on the rare side of your Energy™ Docking 100, and the other end into the output of an audio device like an MP3 player, a console laptop, computer, etc. Press the **b/FUNC** button and select the AU function.

CLOCK RADIO FUNCTION

- ▶ Your Energy™ Docking 100 has two different and independent alarms, you can choose between the iPhone/iPod play list, FM radio or he buzzer.

To set the alarm, the Energy™ Docking 100 has to be in standby mode. Press **VOL+/ALI** to set the first alarm and hold two seconds till you see the time on the display flashing, use **+** and **-** adjust the hour, press again **VOL+/ALI** to adjust the minutes.

When you have the alarm time adjust, press **VOL+/ALI** again to select the alarm sound mode that you want, that is "b (to use the buzzer)", "F (to use the FM radio)" and "I (to use the iPhone/iPod)".

You can set alarm volume level that you want, having a maximum on the scale of 30.

The volume works in an increasing way until the maximum that you select.

Follow the same steps to set the second alarm pressing **VOL-/AL2**.

To turn off the alarm you only have to press **VOL+/ALI** for the first alarm and **VOL-/AL2** for the second alarm.

SNOOZE MODE

- ▶ When the alarm is ringing, presses the **SNOOZE/SLEEP/LIGHT** button to postpone 9 minutes the alarm, after those 9 minutes the alarm will ring again.

SLEEP MODE

- ▶ To program the sleep mode, you have Click "**SNOOZE/SLEEP/LIGHT**" key in the play/ pause status of arbitrary function to set the SLEEP time in turn as: 90/M-80/M-70/M-60/M-50/M-40/M-30/M-20/M- 10/M -OFF. When sleep time arrives, the unit would be automatically powered off. You can set 10 to 90 minutes.

If you want to cancel the sleep mode press to **00**.

WARRANTY

- ▶ Energy Sistem Soyntec SA is liable for any lack of conformity which exists at the time the goods were purchased during a period of 36 months. Batteries are excluded from the 36-month warranty, having a warranty period of 12 months.

This warranty covers any defects in workmanship or materials. This warranty doesn't cover any failure of the product due to accidents, misuse or alteration made by an unauthorized person.

The special 36-months warranty is valid for the European Union. For other countries, please refer to your specific legislation or your local distributor.

WARRANTY PROCEDURE

1. Visit the Support section at <http://support.energysistem.com> and select your product to view the FAQ (Frequently Asked Questions). The solution to your problem is very likely to have been already published there. You will also be able to download user manuals, user guides, drivers and updates. You can check the availability of the user manual in your language at:
<http://www.energysistem.com/es-es/support/manuals>
2. If you cannot find an appropriate solution in the Support section, you may send us your enquiry or warranty service request by email: support@energysistem.com
3. Alternatively, you may prefer to contact the distributor from which you purchased the product, presenting the purchase receipt or invoice.

Important: This warranty doesn't cover any damage or loss to any data stored in the product memory, therefore Energy Sistem's Technical Service will not assume any loss of the above mentioned information so it is recommended to make a backup of your data and to remove any data or personal info from its internal memory before you send the product, or to send it only with the original factory default values.

Trademarks. All company, brand and product names are trademarks or registered trademarks of their respective companies.

© 2012 by Energy Sistem®. All rights reserved.



28/03/2012

DECLARATION OF CONFORMITY

Manufacturer Name: Energy Sistem Soyntec S.A.

Address: Pol. Ind. Finestrat, C/. Calpe, I-03509, Finestrat Alicante (Spain)

Tel: 902 388 388

Fax: 902 119 034

NIF: A53107488

We declare under our own exclusive responsibility that the product:

Energy Sistem® Docking 100™.

Manufacturing country: China



Is in compliance with the essential norms and standards of the Directive 2004/108/EC of the European Parliament and of the Council of December 15th 2004.

This symbol on the product or the instructions means that your electrical and electronic equipment should be disposed at the end of life separately from your household waste. For more information, please contact the local authority or dealer where you purchased the product.