

Varian Vacuum Technologies
121 Hartwell Avenue
Lexington, MA 02421
(781)861-7200

HS-20

Diffusion Pump

Instruction Manual



For sales and service please call:

PTB Sales

Ph. (626) 334-0500

Fax (626) 334-2151

Toll Free 866-332-0500

www.ptb-sales.com



VARIAN

Manual No. 6999-01-120
Revision G
October 2000

Sales and Service Offices

America

Varian Vacuum Technologies

121 Hartwell Avenue
Lexington, MA 02421,
USA
Tel: (781) 861 7200
Fax: (781) 860 5437
Toll Free: 1 (800) 882 7426

Argentina

Varian Argentina Ltd.

Sucursal Argentina
Av. Ricardo Balbin 2316
1428 Buenos Aires
Argentina
Tel: (54) 1 783 5306
Fax: (54) 1 786 5172

Australia

Varian Australia Pty., Ltd.

6/81 Frenchs Forest Road
Frenchs Forest, NSW 2086
Australia
Tel: (61) 2 9975 8805
Fax: (61) 2 9452 2600

Brazil

Varian Industria e Comercio Ltda.

Avenida Dr. Cardoso de Mello 1644
Vila Olimpia
Sao Paulo 04548 005
Brazil
Tel: (55) 11 820 0444
Fax: (55) 11 820 9350

Canada

Varian Canada

6705 Millcreek Drive, Unit 5
Mississauga, Ontario L5N 5R9
Canada
Tel: (800) 882 7426
Fax: (781) 860 5437

China

Varian China Ltd.

Room 1201, Jinyu Mansion
No. 129A Xuanwumen Xidajie
Xicheng District
Beijing 100031
P.R. China
Tel: (86) 10 6641 1530
Fax: (86) 10 6641 1534

Varian Shanghai

Service Station

716 Yishan Road Shanghai
P.R. China 200233
Tel: (86) 21 6483 5576
Fax: (86) 21 6485 9031

England

Varian Ltd.

28 Manor Road
Walton-On-Thames
Surrey KT 12 2QF
England
Tel: (44) 1932 89 8000
Fax: (44) 1932 22 8769

France

Varian s.a.

7 avenue des Tropiques
Z.A. de Courtaboeuf – B.P. 12
Les Ulis cedex (Orsay) 91941
France
Tel: (33) 1 69 86 38 38
Fax: (33) 1 69 28 23 08

Germany

Varian GmbH

Alsfelder Strasse 6
Postfach 11 14 35
64229 Darmstadt
Germany
Tel: (49) 6151 703 353
Fax: (49) 6151 703 302

Hong Kong

Varian Technologies Asia, Ltd.

Rm 2611 Concordia Plaza
New Mandarin Plaza
1 Science Museum Rd.,
Tsimshatsui East, Kowloon
Hong Kong
Tel: (852) 26206173
Fax: (852) 26206338

India

Varian India PVT LTD

1010 Compotent House
7, Nangal Raya Business Centre
New Delhi 110 046
India
Tel: (91) 11 5548444
Fax: (91) 11 5548445

Italy

Varian Vacuum Technologies

via Flii Varian 54
10040 Leini, (Torino)
Italy
Tel: (39) 011 997 9111
Fax: (39) 011 997 9350

Japan

Varian Vacuum Technologies

Sumitomo Shibaura
Building, 8th Floor
4-16-36 Shibaura
Minato-ku, Tokyo 108
Japan
Tel: (81) 3 5232 1253
Fax: (81) 3 5232 1263

Korea

Varian Technologies Korea, Ltd

Shinsa 2nd Bldg. 2F
966-5 Daechi Dong
Kangnam Gu, Seoul
Korea 135-280
Tel: (82) 2 3452 2452
Fax: (82) 2 3452 2451

Netherlands

Varian Vacuum Technologies

Rijksstraatweg 269 H,
3956 CP Leersum
The Netherlands
Tel: (31) 343 469910
Fax: (31) 343 469961

Mexico

Varian S.A.

Concepcion Beistegui No 109
Col Del Valle
C.P. 03100
Mexico, D.F.
Tel: (52) 5 523 9465
Fax: (52) 5 523 9472

Singapore

Varian Asia, Ltd.

1123 Serangoon Road
#03-02
Singapore 328207
Tel: (65) 296 9688
Fax: (65) 296 9733

Spain

Varian Iberica

Avda Pedro Diez 25
28019 Madrid
Spain
Tel: (34) 91 4727612
Fax: (34) 91 4725001

Russia

Varian Moscow

19A Khlebny per
121019 Moscow
Russia
Tel: (70) 95 9374280
Fax: (70) 95 9374281

Taiwan

Varian Technologies Asia Ltd.,

Taiwan Branch

18F-13 No.79, Hsin Tai Wu Road
Sec. 1, Hsi Chih
Taipei Hsien
Taiwan
Tel: (886) 2 2698 9555
Fax: (886) 2 2698 9678

Internet Users:

Visit us on the web at:
www.eVarian.com

Representatives in most countries



VARIAN

Telephone Numbers

For technical support and service within the continental United States, Alaska and Hawaii:

Continental U.S. only – 1-800-8-VARIAN (1-800-882-7426)

Order Entry (Sales)Press 1
Technical Support and Field Service.....Press 2
Training (Information and Registration)Press 3 or 4

Hawaii and Alaska – (781)861-7200

Sales, Service and Product SupportPress 1
For other departments.....Press 3

FAX Numbers

Order Entry (Sales)FAX (781) 860-5405
Technical Support.....FAX (781) 860-5465
Field ServiceFAX (781) 860-9210
Training (Information and Registration)FAX (781) 860-5479

Copyright © by Varian, Inc. All rights reserved.

This manual may not, in whole or in part, be copied, photocopied, reproduced, translated, or converted to any electronic or machine-readable form without prior written consent of Varian Vacuum Technologies, Lexington, MA 02421-3133

Warranty

Products manufactured by Seller are warranted against defects in materials and workmanship for twelve (12) months from date of shipment thereof to Customer, and Seller's liability under valid warranty claims is limited, at the option of Seller, to repair, replacement, or refund of an equitable portion of the purchase price of the Product. Items expendable in normal use are not covered by this warranty. All warranty replacement or repair of parts shall be limited to equipment malfunctions which, in the sole opinion of Seller, are due or traceable to defects in original materials or workmanship. All obligations of Seller under this warranty shall cease in the event of abuse, accident, alteration, misuse, or neglect of the equipment. In-warranty repaired or replacement parts are warranted only for the remaining unexpired portion of the original warranty period applicable to the repaired or replaced parts. After expiration of the applicable warranty period, Customer shall be charged at the then current prices for parts, labor, and transportation.

Reasonable care must be used to avoid hazards. Seller expressly disclaims responsibility for loss or damage caused by use of its Products other than in accordance with proper operating procedures.

Except as stated herein, Seller makes no warranty, express or implied (either in fact or by operation of law), statutory or otherwise; and, except as stated herein, Seller shall have no liability under any warranty, express or implied (either in fact or by operation of law), statutory or otherwise. Statements made by any person, including representatives of Seller, which are inconsistent or in conflict with the terms of this warranty shall not be binding upon Seller unless reduced to writing and approved by an officer of Seller.

Warranty Replacement and Adjustment

All claims under warranty must be made promptly after occurrence of circumstances giving rise thereto, and must be received within the applicable warranty period by Seller or its authorized representative. Such claims should include the Product serial number, the date of shipment, and a full description of the circumstances giving rise to the claim. Before any Products are returned for repair and/or adjustment, written authorization from Seller or its authorized representative for the return and instructions as to how and where these Products should be returned must be obtained. Any Product returned to Seller for examination shall be prepaid via the means of transportation indicated as acceptable by Seller. Seller reserves the right to reject any warranty claim not promptly reported and any warranty claim on any item that has been altered or has been returned by non-acceptable means of transportation. When any Product is returned for examination and inspection, or for any other reason, Customer shall be responsible for all damage resulting from improper packing or handling, and for loss in transit, notwithstanding any defect or non-conformity in the Product, in all cases, Seller has the sole responsibility for determining the cause and nature of failure, and Seller's determination with regard thereto shall be final.

If it is found that Seller's Product has been returned without cause and is still serviceable, Customer will be notified and the Product returned at its expense; in addition, a charge for testing and examination may be made on Products so returned.

OPERATION AND MAINTENANCE OF THIS EQUIPMENT INVOLVES SERIOUS RISK. IT IS THE RESPONSIBILITY OF THE USER TO MAINTAIN SAFE OPERATING CONDITIONS AT ALL TIMES. VARIAN ASSUMES NO LIABILITY FOR PERSONAL INJURY OR DAMAGE RESULTING FROM OPERATION OR SERVICE OF THE EQUIPMENT.

Carelessly or improperly operated equipment can cause serious injury or death and/or damage to the equipment. The emergency and safety procedures in this manual are provided to help users and qualified persons to operate and service the unit safely. Recommendations are believed to reflect accepted industry practices in effect on the date of publication of this manual. Special applications must be reviewed and approved by an industrial hygienist or chemical safety engineer.

Varian has no control over the use of this equipment and is not responsible for personal injury or damage resulting from its use. The safe use and disposal of hazardous or potentially hazardous materials of any kind is the sole responsibility of the user. Observe all WARNINGS and CAUTIONS to minimize the serious hazards involved.

It is the sole responsibility of users of Varian equipment to comply with all local, state, and federal safety requirements (laws and regulations) applicable to their system. Employ the services of an industrial hygienist and/or a qualified chemical safety engineer in order to ensure safe installation and use.

This instruction manual contains information which will assist qualified operators in the operation, and qualified service engineers to carry out field-servicing the Varian equipment.

SAFE INCORPORATION OF VARIAN DIFFUSION PUMPS INTO VACUUM SYSTEMS IS THE RESPONSIBILITY OF THE SYSTEMS DESIGNER. TAKE APPROPRIATE ACTION THROUGH REDUNDANCY, AND/OR OTHER SAFEGUARDS TO PROTECT PERSONNEL AND PROPERTY FROM THE HAZARDS DESCRIBED BELOW AND IN THE INSTALLATION, OPERATION, AND MAINTENANCE INSTRUCTION MANUAL. SAFE OPERATION IS THE RESPONSIBILITY OF THE USING ORGANIZATION AND ITS PERSONNEL. READ THE INSTRUCTION MANUAL AND UNDERSTAND HOW TO AVOID HAZARDS PRIOR TO OPERATING THE DIFFUSION PUMP. ALL PERSONS WHO WORK WITH OR ARE EXPOSED TO DIFFUSION PUMPS OR EQUIPMENT WHICH UTILIZES SUCH PUMPS OR DIFFUSION PUMP FLUID MUST TAKE PRECAUTIONS TO PROTECT THEMSELVES AGAINST POSSIBLE SERIOUS BODILY INJURY OR DEATH. DO NOT BE CARELESS AROUND SUCH PRODUCTS.

THESE SHEETS AND THE INSTALLATION, OPERATION, AND MAINTENANCE INSTRUCTIONS CAN HELP YOU TO OPERATE THIS PUMP SAFELY AND EFFICIENTLY. READ THEM. SPECIAL OPERATING CONSIDERATIONS AND PRECAUTIONS WILL BE FOUND IN THE OPERATION INSTRUCTIONS. UNINFORMED OR CARELESS OPERATION OF THIS PUMP CAN RESULT IN POOR PERFORMANCE, DAMAGE TO THE PUMP OR OTHER PROPERTY, SERIOUS BODILY INJURY, AND POSSIBLE DEATH.

USERS OF THIS EQUIPMENT SHOULD BE ALERT TO TWO LEVELS OF HAZARDS IDENTIFIED BY THE FOLLOWING SYMBOLS:



WARNING

Warnings are used when failure to observe instructions or precautions could result in injury or death to humans.



CAUTION

Cautions are used when failure to observe instructions could result in significant damage to equipment and/or facilities.

Designers of systems which utilize diffusion pumps must design out hazards wherever possible; provide guards, safety features, and interlocks for hazards which cannot be designed out; warn with respect to hazards which cannot be designed out and which remain after utilizing guards, safety features, and interlocks; and lastly, provide procedures and instructions on proper use, servicing, etc., so as to minimize risk.

THE INSTALLATION, OPERATION, AND/OR SERVICING OR DIFFUSION PUMPS INVOLVES ONE OR MORE OF THE FOLLOWING HAZARDS, ANY ONE OF WHICH, IN THE ABSENCE OF SAFE OPERATING PRACTICES AND PRECAUTIONS, COULD POTENTIALLY RESULT IN DEATH OR SERIOUS HARM TO PERSONNEL.

| Hazard | Suggested Corrective Action |
|--|--|
| Loss of utility: water and/or electricity | Provide sufficient backup water and power supply as necessary to effect a safe shutdown under worst case conditions. |
| Overpressure in foreline | Provide an interlock to ensure that the power supply to the pump heater cannot be activated if the foreline pump is not running AND/OR pressure in foreline is above 0.5 Torr (66.5 Pa). |
| Overtemperature | Fit temperature sensors and pump fluid level sensors with feedback to an interlock on the heater power supply. |
| Insufficient water flow through the maincooling coils | Use water flow sensor and feedback to interlock the heater power supply. |
| Water trapped between inlet and outlet of quick-cool coil, or liquid nitrogen trapped between inlet and outlet of liquid nitrogen trap | Provide vent or pressure relief valves for both quick-cool coil and liquid nitrogen trap. |
| Loss of ground integrity | Incorporate ground fault interrupt circuit into heater power supply. |
| Positive pressure in pumping system | Integrate pressure relief valve in vacuum system. |
| High voltage | Prevent personnel contact with high voltages; design and attach warnings. |
| Toxicity/Corrosivity | Toxic and/or corrosive gases must be vented to a safe location, ensuring adequate dilution or scrubbing to safe levels, taking all action required to meet air quality standards. |
| Explosion | Integrate pressure relief valves in all systems using pumps 10 inches or larger in diameter. Do not use or recommend the use of hydrocarbon-based pumping oils. |

Hazard**Suggested Corrective Action**

- a. Explosion** – Operation of the diffusion pump without prior and continuous evacuation (below 0.5 Torr (66.5 Pa)) or coolant and introducing a strong oxidizer (such as air) or explosive vapors or powders or materials which may react with pumping fluids into a hot (above 300°F or 150°C) pump can cause an explosion. Such an explosion can violently expel valves and other hardware, slam open doors that are not designed for appropriate pressure relief, or burst other components of the vacuum system. Serious injury or death may result from expelled parts, doors, shrapnel, and/or shock waves.
- b.** All diffusion pumps are typically cleaned with acetone and alcohol. When combined with air, oxygen, and other oxidizers, alcohol and most other solvents are very flammable and explosive. Never permit any trace of these cleaners to remain in or on the pump. Always remove all traces of alcohol and acetone and other cleaners with clean, dry, oil-free compressed air.

Three elements are required: fuel, oxidizer, and source of ignition. A combination of temperature and pressure can be a source of ignition. Most diffusion pump fluids except mercury are fuels. Hydrocarbon oils are more prone to oxidize and explode than synthetic silicone-based oil. Oxidizer can be air (a strong oxidizer) from a leak or can be deliberately introduced in a process or can be inadvertently admitted to the system by operator or process controller error. Oxygen and other strong oxidizers are even more dangerous. Certain conditions of temperature and pressure can cause a combustible mixture to explode. The larger the diffusion pump, the greater the risk of explosion and the greater the risk of damage and/or injury. Never operate diffusion pumps larger than 10 inches in diameter with hydrocarbon oils without a complete safety analysis for the complete system and application. Never operate any diffusion pump in the following ways because they increase the probability of an explosion.

| Prohibited Action | Explosion-Causing Condition |
|--|------------------------------------|
| Run pump with no cooling water | Overtemperature |
| Run pump with low level of pump fluid | Overtemperature |
| Run pump without proper backing or holding pump | Overpressure |
| Run pump when not evacuated below 0.5 Torr (66.5 Pa) | Overpressure |
| Admit air to, or rough through, a pump with hot boiler | Overpressure plus strong oxidizer |
| Open drain or fill plug while pump is under vacuum especially when it is hot | Overpressure plus strong oxidizer |

| Prohibited Action | Explosion-Causing Condition |
|--|--|
| Contaminate pump with explosive vapors, powders, or reactive materials | Lower explosive threshold of gas mixtures |
| Remove, defeat, or override safety counter-measures such as pressure and thermal switches and valve sequencer interlocks | Overtemperature, overpressure, more combustible mixtures |
| Machine or weld without removing all oil or solvent residue in pump | Source of ignition |
| Use unsuitable pumping fluid especially in large pumps | Lower explosive threshold of gas mixture |

Systems larger than 10 inches must be designed with pressure relief devices to provide safe pressure relief from internal explosions. Always recognize that safety devices can fail or malfunction; provide redundant protection by installing devices having different failure modes, failure mechanisms, and failure causes. Be certain that exhaust duct materials are capable of withstanding the corrosivity, temperature, and pressure of exhausted products.

c. Pressure – Pumps and their components are designed for vacuum service; they are not designed to be pressurized which could cause them to burst possibly expelling shrapnel at lethal velocities. Serious accidents have been caused by intentional pressurization of vacuum systems and their components. **Never pressurize any part of a vacuum system for test or any other purpose..** Always provide pressure relief when designing diffusion pumps into systems and ensure that pressure relief motion is limited to safe envelopes. Never permit the following:

| Prohibited Action | Result |
|---|---|
| Block inlet and vent of liquid nitrogen trap and lines | LN ₂ trap and/or lines burst |
| Close isolation valves at inlet and discharge of main watercooling coils and pump is reheated | Water turns to steam and bursts coils |
| Pressurize pump body | Body of pump bursts |
| Hole through vacuum wall | Loss of structural integrity of wall |

- d. Poisonous and/or Corrosive Compounds** – When pumping poisonous, reactive, and/or corrosive gas, vapors, or chemicals, even proper operation and regeneration will not always ensure that all hazardous materials have been totally removed. If hazardous gas, vapors, chemicals, or combustible mixtures are pumped, sufficient quantities may exist during operation or remain after regeneration to cause severe injury or death. Overheating the pump oil, exposing it to air or reactive materials, or overpressurizing it above the normal operating range (approximately 1 mTorr (.133 Pa)) will decompose the oil and possibly make it toxic. This is especially true of backstreamed mechanical pump oils which are more volatile (unstable). Overheating of accidentally introduced or backstreamed mechanical pump oils cannot be protected against by thermal switches which are set for diffusion pump oil.

Refer to specific instruction manuals for detailed instructions and precautions. Always vent the pump and relief valve to a safe location thus ensuring adequate dilution to safe levels, and take all other action required to meet quality air standards. Always handle pump fluids and hardware with an awareness of the possible deadly hazards involved and the necessity for great care and attention to safety precautions.

Diffusion pumps are typically cleaned with acetone or alcohol. Acetone, alcohol, and most other solvents are irritants, narcotics, and depressants, and/or carcinogenic. Their inhalation and ingestion may produce serious effects. Even absorption through the skin can result in moderate toxicity. Always ensure that cleaning operations are performed in large, well-ventilated rooms. Use of self-contained breathing apparatus may be necessary depending upon the solvent type and vapor concentration in surrounding air.

- e. High Voltage** – Diffusion pumps operate at voltages high enough to kill through electrical shock. Design equipment utilizing these pumps to prevent personnel contact with high voltages. Securely attach prominent hazard warnings. Personnel should always break the primary circuit to the power supply when direct access to the heater or wiring is required.
- f. Hot Surfaces** – Boiler temperatures reach 530°F (275°C) which can cause serious burns when touched. Always ensure that surfaces have cooled near room temperature before touching them.
- g. Hot Coolant and/or Steam** – The water used to cool the pump can reach scalding temperatures. Touching or rupture of the cooling surface can cause serious burns. Water left inside quick cool coils from previous use will turn to steam when the pump is reheated. This steam must be allowed to escape without contacting personnel. Whenever possible, design the water system with interlock valves so that power cannot be applied to the pump unless water is flowing in the main cooling coils (not quick-cooling coils).
- h. Cold Surfaces** – Liquid nitrogen traps cooled by liquid nitrogen are commonly used in diffusion pumps. Metal surfaces at liquid nitrogen temperature can cause severe frostbite if contacted by unprotected skin. These surfaces remain cold for some time (at least a half hour) after the liquid nitrogen has evaporated.

- i. **Cold Coolant** – Liquid nitrogen, a cryogenic liquid, is used in traps. If it is splashed on body tissues or eyes, it can cause severe frostbite or blindness. The extremely low temperature of liquefied nitrogen can cause skin damage similar to high temperature burns. Contact with the cold gas evolving from the liquid may produce the same effect. Delicate tissues, such as the eye tissues, are most easily damaged by exposure to cold gas or liquid. To minimize the risk of hazardous contact of cold gaseous nitrogen with any part of the body, wear personal safety equipment recommended for use with cryogenic materials including face shield, full-sleeved lab coat, and clean, dry gloves which fit loosely so they can be thrown off quickly if frozen by contact with the gas.
- j. **Asphyxiation** – If a large amount of liquid nitrogen is spilled in a small, poorly ventilated room or equipment, death from suffocation can result. All diffusion pumps are typically cleaned with acetone or alcohol. Acetone, alcohol, and most other solvents are very volatile (unstable). During cleaning, the volatility of these cleaners may permit their gases to displace air and its life-supporting oxygen which could cause death or serious injury by asphyxiation. Always ensure that cleaning operations are performed in large, well-ventilated areas.

While still hot, the diffusion pump may also contain decomposed and/or overheated pump oils which can also be an asphyxiant.

- k. **Large, Heavy Weights** – Diffusion pumps larger than 10 inches in diameter require power-assisted equipment and the use of trained moving/installation personnel in order to avoid dropping, slipping, and/or overturning the pump thus severely injuring personnel. Check weight of equipment before lifting and do not stand under equipment being moved.

 **WARNING**

High voltages (up to 480 V) can kill. Always break the primary circuit to the power supply before starting to work on the heater and/or its wiring.

 **WARNING**

Diffusion pumps are typically cleaned with acetone, alcohol, or other solvents.

When heated, sprayed or exposed to high temperature equipment, these solvents become flammable and explosive, causing serious injury or death. **Do Not Use Near A High-Temperature Source.** Ventilate working area with a blower and use in large, well-ventilated room. When heated or sprayed, acetone also becomes 4 to 5 times heavier than air and will flow down, settling in tanks, pits, and low areas, thus displacing air which can kill by asphyxiation. Use in a large, well-ventilated room. Use of a self-contained breathing apparatus may be necessary.

Acetone, alcohol, and other solvents are irritants, narcotics, depressants, and/or carcinogenics. Their inhalation and/or ingestion may produce serious effects. Prolonged or continued contact with the skin will result in absorption through the skin and moderate toxicity. Always ensure that cleaning operations are carried out in large, well-ventilated rooms, and wear eyeshields, gloves, and protective clothing.

 **WARNING**

Varian has no control over the types of gases passing through this pump. These are entirely under the control of the process user and/or the hardware systems integrator. Frequently, process gases are toxic, flammable, corrosive, explosive, or otherwise reactive. Since these gases can cause serious injury or death, it is very important to plumb the exhaust of the pump to the facility's hazardous gas exhaust system which incorporates appropriate filters, scrubbers, etc., to insure that the exhaust meets all air and water pollution control regulations

 **WARNING**

Certain gases can become corrosive and toxic when trapped in oil. Always wear protective gloves when handling dirty pump oil, drain it into a closable container, and do not breathe the fumes of the oil. Always use fully self-contained breathing apparatus.

 **WARNING**

If hazardous gas, vapors, chemicals, or combustible mixtures are pumped, sufficient quantities may exist during operation. This pump may contain decomposed and/or overheated pump oils or poisonous and/or corrosive process materials which are highly toxic and also can be an asphyxiant. Proper operation will not always ensure that all hazardous materials have been removed.

 **WARNING**

Hot oils can cause serious burns. Wear protective gloves and long sleeved, loose fitting, heat resistant garments when draining pump oil.

 **WARNING**

When lifting some Varian diffusion pumps, use power-assisted equipment and trained moving/installation personnel to avoid dropping, slipping, and/or overturning the pump and severely injuring personnel. Check weight of equipment before lifting and do not stand under equipment being moved.

 **CAUTION**

Acetone, alcohol, and other solvents degrade O-ring materials reducing their ability to hold a vacuum. Do not use acetone or other solvents on O-rings. If necessary to clean O-rings, wipe with lint-free, clean cloth, wash in detergent and water, or use a small amount of pump oil.

 **NOTE**

Always dispose of used or dirty oil properly and in compliance with all local, state, and federal environmental laws and regulations.

Table of Contents

| Section | Page |
|---|-------------|
| Safety Considerations | i |
| Section I – Installation | 1-1 |
| 1-1 General | 1-1 |
| 1-2 Operating Specifications | 1-1 |
| 1-3 Physical Specifications | 1-2 |
| 1-4 Unpacking | 1-4 |
| 1-5 Cleaning a New Pump | 1-4 |
| 1-6 Utility and System Connections | 1-6 |
| 1-7 Adding Pump Fluid | 1-11 |
| Section II – Operation | 2-1 |
| 2-1 Start-up Procedure | 2-1 |
| 2-2 Shutdown Procedure | 2-2 |
| Section III – Maintenance | 3-1 |
| 3-1 General | 3-1 |
| 3-2 Periodic Inspection | 3-1 |
| 3-3 Cleaning | 3-2 |
| 3-4 Disassembling and Reassembling the Cold Cap | 3-3 |
| 3-5 Disassembling and Reassembling the Jet Assembly | 3-5 |
| 3-6 Heater Replacement | 3-7 |
| 3-7 Replaceable Parts | 3-11 |
| Section IV – Troubleshooting | 4-1 |
| 4-1 Leakage | 4-1 |
| 4-2 Outgassing | 4-1 |
| 4-3 Poor Pump or System Performance | 4-1 |

List of Illustrations

| Figure | Title | Page |
|---------------|---|-------------|
| 1-1 | Speed and Throughput Curves – HS-20 Diffusion Pump | 1-2 |
| 1-2 | Outline Drawing – HS-20 Diffusion Pump | 1-3 |
| 1-3 | Cooling Water Connections | 1-7 |
| 1-4 | 200/240/400/430/440/480 V Wiring Diagram – HS-20 Diffusion Pump | 1-9 |
| 1-5 | 380/415V Wiring Diagram – HS-20 Diffusion Pump | 1-10 |
| 1-6 | Sight Glass Assembly | 1-12 |
| 3-1 | External Fittings – Cold Cap Assembly | 3-4 |
| 3-2 | 20-inch Jet Assembly | 3-6 |
| 3-3 | Jet Coupling | 3-8 |
| 3-4 | Heater Element Assembly | 3-9 |

List of Tables

| Table | Title | Page |
|--------------|-----------------------|-------------|
| 1-1 | Specifications | 1-1 |
| 4-1 | Troubleshooting | 4-1 |

SECTION I

INSTALLATION

1-1 GENERAL

Upon receipt, inspect the container for evidence of damage in shipment. Do not discard any evidence of rough handling. Factory packing provides for maximum protection during shipment. However, the pump should be inspected immediately and any damage should be reported to the carrier without delay.

Before unpacking and installing the pump, the user should thoroughly familiarize himself with the contents of this instruction manual, particularly the physical and operating specifications listed in the following paragraphs, in order to gain a better understanding of the operating principles, limitations, correct application of the diffusion pump, the hazards involved, and what to do and what not to do in order to avoid these hazards.

1-2 OPERATING SPECIFICATIONS (See Figure 1-1)

Table 1-1 lists the specifications for all standard models of the HS-20 diffusion pump.

Table 1-1. HS-20 Diffusion Pump Specifications

| Model | Technical Specifications |
|---|--|
| Optimum Operating Range | 6 x 10 ⁻⁴ Torr to < 1 x 10 ⁻⁹ Torr 8 x 10 ⁻² Pa to < 1.3 x 10 ⁻⁷ Pa 7.8 x 10 ⁻⁴ mbar to < 1.3 x 10 ⁻⁹ Torr |
| Maximum Pumping Speed (See Figure 1-1) | 17,500 liters/sec for air 21,000 liters/sec for helium |
| Maximum Throughput at 1 x 10 ⁻² Torr | 18 Torr-liters/sec 2394 Pa-liters/sec 23.4 mbar-liters/sec |
| Maximum Forepressure | No Load: 0.65Torr; 86.5 Pa; 0.85 millibar Full Load: 0.55Torr; 73.2 Pa; 0.72 mbar |
| Backstreaming Rate at Pump Inlet | 0.0015 mg/cm ² /min |
| Power Required (approximately) | 12 KW, 240/380/480V, 50/60 Hz, 3-phase |
| Warmup Time | 45 minutes |
| Cooldown Time(using quick cool) | 85 minutes (45 minutes) |
| Fluid Charge | 5 U.S. quarts (4.75 liters) |
| Cooling Water Requirements | 1.5 gpm at 60°F to 80°F inlet temperatures |
| Pressure drop across cooling circuits of cold cap and body in series | 15 psi |
| Backing Pump Size Recommended | 100 cfm for maximum throughput |

Installation

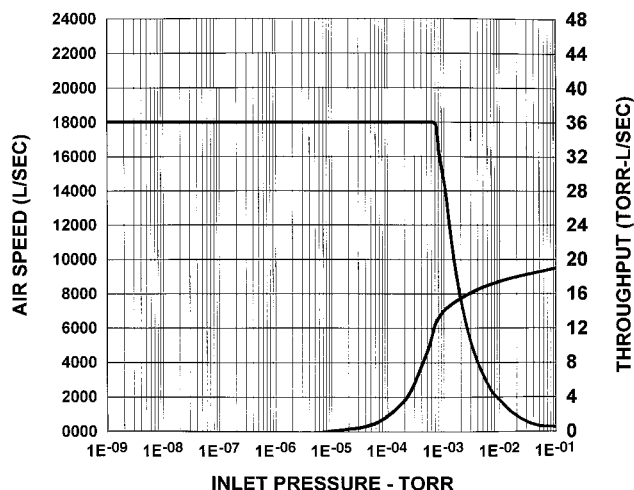

Figure 1-1. Speed and Throughput Curves – HS-20 Diffusion Pump

1-3 PHYSICAL SPECIFICATIONS (See Figure 1-2)

Flange dimensions (inches):

| | ASA | | ISO 630k | ISO 160k |
|---------------|----------------------|-----------------|---|---|
| | Inlet | Foreline | Inlet | Foreline |
| OD | 27.50 | 9.0 | 27.17 | 7.09 |
| ID | 21.25 | 5.06 | 21.25 | 5.06 |
| Thickness | 1.12 | 0.75 | 0.78 | 0.47 |
| Bolt Circle | 25.0 | 7.5 | Requires NW-630 Centering Ring (not included with pump) | Requires NW-160 Centering Ring (not included with pump) |
| No. of Holes | 20.0 | 8.0 | | |
| Size of Holes | 1.25 | 0.75 | | |
| Orientation | Straddle center line | | | |
| Gasket Groove | ID | 21.625 | 5.31 | |
| | wide | 0.48 | 0.375 | |
| | deep | 0.25 | 0.09 | |

Height 48 inches; allow additional
8 inches (min) for heater removal

Jet Assembly 5-stage, Self-aligning, fractionat-
ing design with four diffusion
stages and one ejector stage

**Foreline
Baffle** Stacked disk and ring

Cold Cap Water-cooled

**Water
Connections** ¼ FPT body and foreline
⅜ quick cool coils

**Thermal
Switches** Upper set at 185°F (29°C)
Lower set at 390°F (93°C)

Materials Body: Mild steel
Flanges: Mild steel
Jet Assembly: Aluminum
Foreline Baffle: Stainless Steel
Cooling Coils: Copper
Quick Cool Coils: Stainless Steel
Cold Cap: Copper (Nickel-plated)

Weight 500 pounds

**Shipping
Weight** 580 pounds

Installation

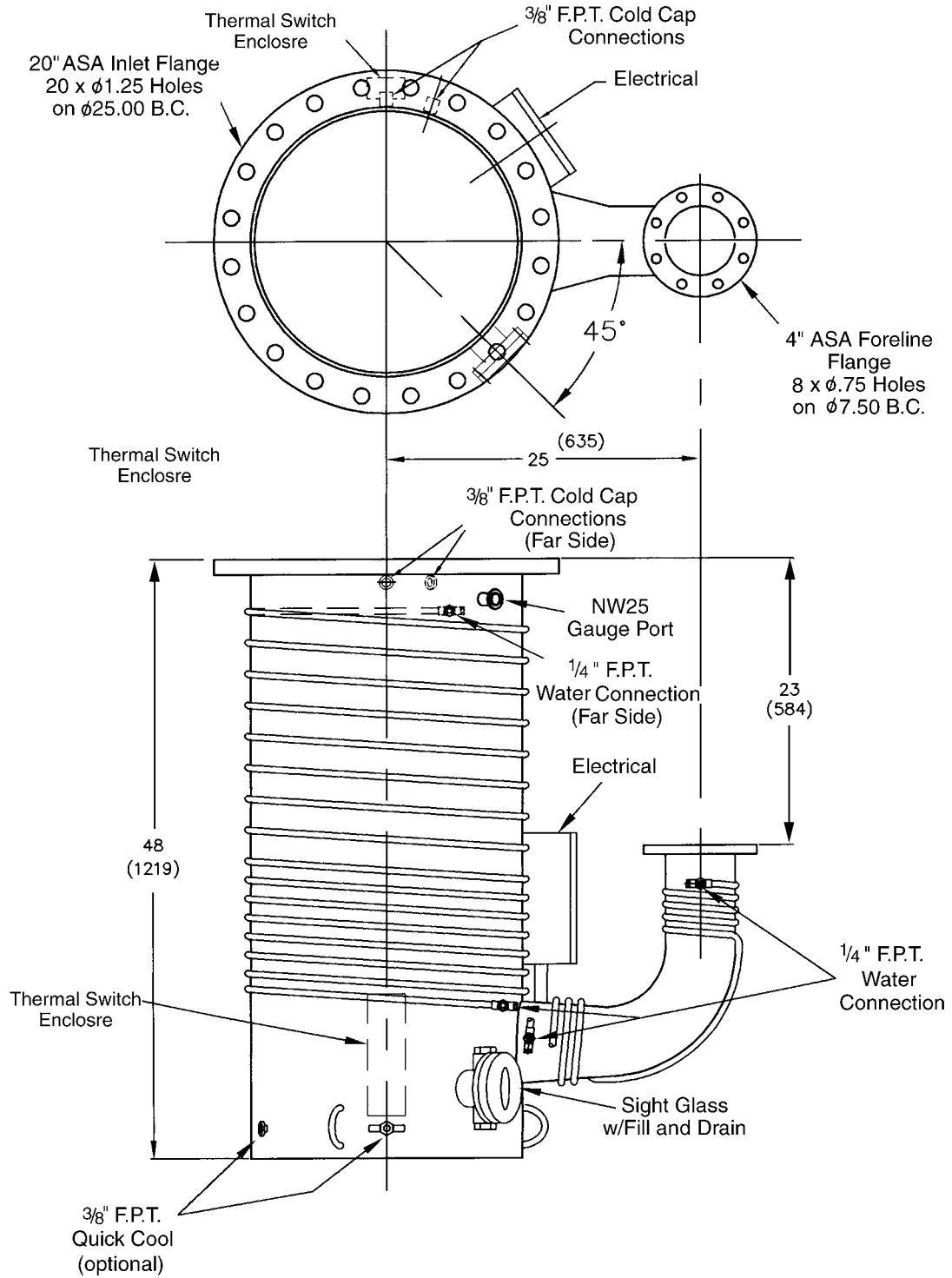

Figure 1-2. Outline Drawing – HS-20 Diffusion Pump, with ASA Flanges

1-4 UNPACKING

Pumps are factory-packaged to permit prolonged storage in suitably protected areas without special precautions.



WARNING

When lifting some Varian diffusion pumps, use power-assisted equipment and trained moving/installation personnel to avoid dropping, slipping, and/or overturning the pump and severely injuring personnel. Check weight of equipment before lifting and do not stand under equipment being moved.

- a. Remove flange covers, blank plugs, protective plugs from water connections, etc. Be careful not to scratch or otherwise damage or mark the sealing surface — usually an O-ring groove on top of the large inlet flange.
- b. Carefully remove the outer shipping container and save it for evidence if damaged. Notify the carrier immediately. Visually inspect the pump for damage that may have occurred during shipping. Discard any internal packing which may have been used to protect the internal components.
- c. For non-critical work, after making sure that there are no foreign materials inside the pump, it may be charged with fluid and used without disassembly. Otherwise, it should be disassembled and cleaned. In general, cleaning may be required if the expected vacuum level is to be below the 10^{-6} Torr (.000133 Pa) range.
- d. Check the internal jet assembly. It should be concentric and firmly seated on the bottom of the pump. Using a flashlight, check to make sure that the ejector nozzle is opposite the foreline (the pump outlet connection). The jet assembly should not rotate because of an indexing pin at the bottom.

1-5 CLEANING A NEW PUMP

- a. Remove the cold cap as described in Section III, para. 3-4, of this manual.
- b. Disassemble the internal jet system from the body of the pump. See Figure 3-2 for a section drawing of a typical jet assembly.
- c. Remove fill and drain plugs and the sight glass with its O-ring and graphite gasket.
- d. Thoroughly clean all components of the jet assembly and pump casing interior (but not O-rings) with acetone followed by an alcohol rinse.

 **WARNING**

Diffusion pumps are typically cleaned with acetone, alcohol, or other solvents.

When heated, sprayed or exposed to high temperature equipment, these solvents become flammable and explosive, causing serious injury or death. **Do not use near high temperature source.** Ventilate working area with a blower and use in large, well-ventilated room. When heated or sprayed, acetone or alcohol also becomes 4 to 5 times heavier than air and will flow down, settling in tanks, pits, and low areas, thus displacing air which can kill by asphyxiation. Use in a large, well-ventilated room. Use of a self-contained breathing apparatus may be necessary.

Acetone, alcohol, and other solvents are irritants, narcotics, depressants, and/or carcinogenics. Their inhalation and/or ingestion may produce serious effects. Prolonged or continued contact with the skin will result in absorption through the skin and moderate toxicity. Always ensure that cleaning operations are carried out in large, well-ventilated rooms, and wear eyeshields, gloves, and protective clothing.

- e. Remove all traces of the cleaning fluid by carefully drying with clean, dry, oil-free compressed air.
- f. For reassembly, reverse the above procedure.
- g. Clean the flanges and O-ring grooves thoroughly with acetone or alcohol, using clean, lint free rags.

 **CAUTION**

Alcohol, acetone, and other solvents degrade O-ring materials reducing their ability to hold a vacuum. Do not use any solvents on O-rings. If necessary to clean O-rings, wipe with lint-free, clean cloth, wash in detergent and water, or use a small amount of pump oil.

- h. Remove all traces of acetone or alcohol by carefully drying with clean, dry, oil-free compressed air. Install O-ring gasket.

1-6 UTILITY AND SYSTEM CONNECTIONS

1-6-1 Safety Considerations and Interlocks

- a. Large pumps are equipped with two thermal switches. Both thermal switches on the HS-20 diffusion pump are mounted on a thermal strap located on the side of the pump. These thermal switches are supplied **normally closed**. The thermal switches have been designed so that a cooling water failure, high inlet pressure, or low oil level in the boiler will result in an increase in temperature, causing the **normally closed** contacts of the switches to open. When the problem has been corrected and the temperature lowered, the thermal switch will automatically reset itself.

⚠ WARNING

Utility failure can cause damage to the equipment, overheating, and possible explosions. Designers of the equipment using diffusion pumps must design their system to protect personnel and property from possible hazards.

- b. A small lamp of the same voltage as the diffusion pump heater may be connected across the terminals of the thermal switch. The lamp will normally be shunted by the contacts. However, when the contacts open, the lamp will receive full line voltage and give a visual trouble indication.

1-6-2 Vacuum Connections

- a. The pump must be installed with the body vertical and plumb. Check that the mating flange on the system (to the pump inlet) is horizontal within plus or minus 1 degree. If this condition is not met, correct the system before installing the pump. The boiler of the pump (especially for large pumps) must be horizontal to prevent uneven fluid level and avoid local overheating where the fluid level would be too shallow.
- b. Prepare inlet O-ring seals by wiping them with a clean cloth. Do not use solvents. Use a small amount of diffusion pump oil to wet the cleaning cloth. Install the O-ring in the groove being careful not to damage the sealing surface with cuts, nicks, or scratches.
- c. Using appropriate lifting apparatus, align the bolt holes of the flanges and assemble the bolts. Tighten the bolts evenly to compress the O-ring seal until light contact is achieved between metal flanges.
- d. Check fill and drain plugs and the sight glass assembly for tightness. Apply light to medium torque, enough to compress gaskets. Minute leaks through the gaskets may develop with use in this location. They may be detectable with very sensitive mass spectrometer leak detectors.

1-6-3 Cooling Water Connections (See Figure 1-3)

The following method of external connections is recommended.

- a. Water connections are designed for $\frac{1}{4}$ FPT fittings. The cold cap cooling coil and all of the body and foreline cooling should be connected in series. A cooling water supply of 1.5 gpm at 60°F to 80°F (16°C to 27°C) should be adequate. A higher flow than this will not be harmful.

Installation

The cooling water discharge should, if possible, be connected to an open drain so that cooling water flow can readily be checked. The temperature of the discharged cooling water should not exceed 130°F (54°C).

- b. The quick-cool coil at the boiler plate **must** be connected to an open drain and the feed line controlled by a separate water 3-way valve (open, closed, and vent to atmosphere). The drain must be below the boiler level so that it is drained completely when the quick-cool coil water supply is shut off and the pump is operating.

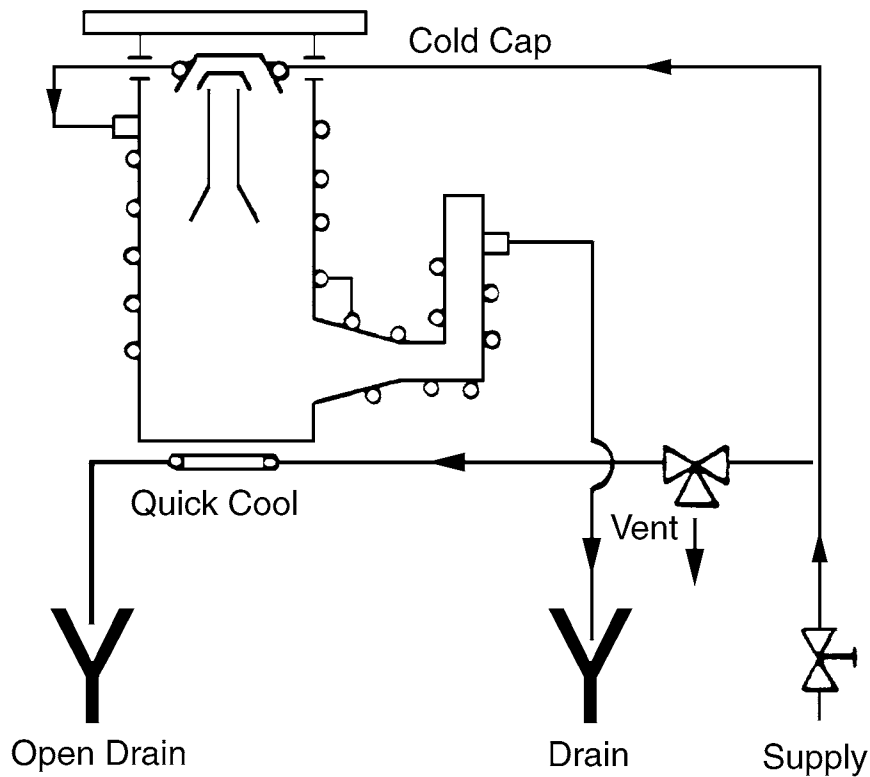

Water Requirements:

1.5 gallons per minute at 60° to 80° inlet temperature pressure drop across series circuit of cold cap and body – 15 PSI

Figure 1-3. Cooling Water Connections

1-6-4 Electrical Connections (See Figure 1-4 and 1-5, Diffusion Pump Wiring Diagram)



WARNING

High voltages (up to 480V) can kill. Always break the primary circuit to the pump before starting to work on the heater and/or its wiring.

- a. The pump heater has been designed to operate at a certain voltage. Check the heater for correct supply voltage and, in the case of multiphase connections, for load balance by measuring the resistance of each branch. (See pages 1-9, 1-10 for proper resistance.)
- b. Make connections to the terminals in the junction box (at the foreline). The use of flexible conduit is recommended to facilitate removal of the pump for service. The pump should not be operated at more than 5% over the rated voltage. Make connections in accordance with the wiring diagram provided with each pump.

1-6-5 Thermal Switches

The thermal switches have been pre-set at the factory and should not require adjustment. The lower thermal switch is set at 390°F; the upper switch is set at 185°F. Should any thermal switch be thrown out of adjustment, it can be adjusted as follows.

1. Boiler thermal switch

The boiler thermal switch is mounted on the bottom of the brass strap on the side of the pump. The thermal switch should be adjusted, with the pump operating, as follows:

- a) After several hours operation, disconnect the lead wires and place an ohmmeter across the terminals of the thermal switch.
- b) Turn the adjusting screw until $\frac{1}{16}$ of a turn either way will make the contact open or close.
- c) Turn the adjusting screw clockwise $\frac{1}{4}$ turn.

2. Cooling water thermal switch

The cooling water thermal switch is mounted on the top of the same brass strap located on the side of the pump. The switch should be adjusted with the pump in operation as follows:

- a) Disconnect the lead wires and place an ohmmeter across the terminals of the switch.
- b) Turn the switch adjusting screw until $\frac{1}{16}$ of a turn either way will make the contact open or close.
- c) Turn the adjusting screw clockwise $\frac{1}{4}$ turn.

Thermal switches are to be operated on AC power only and should be connected in series with the coil of the diffusion pump heater contactor.

1-6-6 Initial Vacuum Test

The purpose of this test is to establish the leak tightness of the system, specifically the vacuum connections to the diffusion pump. (To eliminate misleading indications and the masking of leaks by the fluid, the tests should be carried out with the diffusion pump "dry", i.e., before it is charged with the pumping fluid.)

Installation

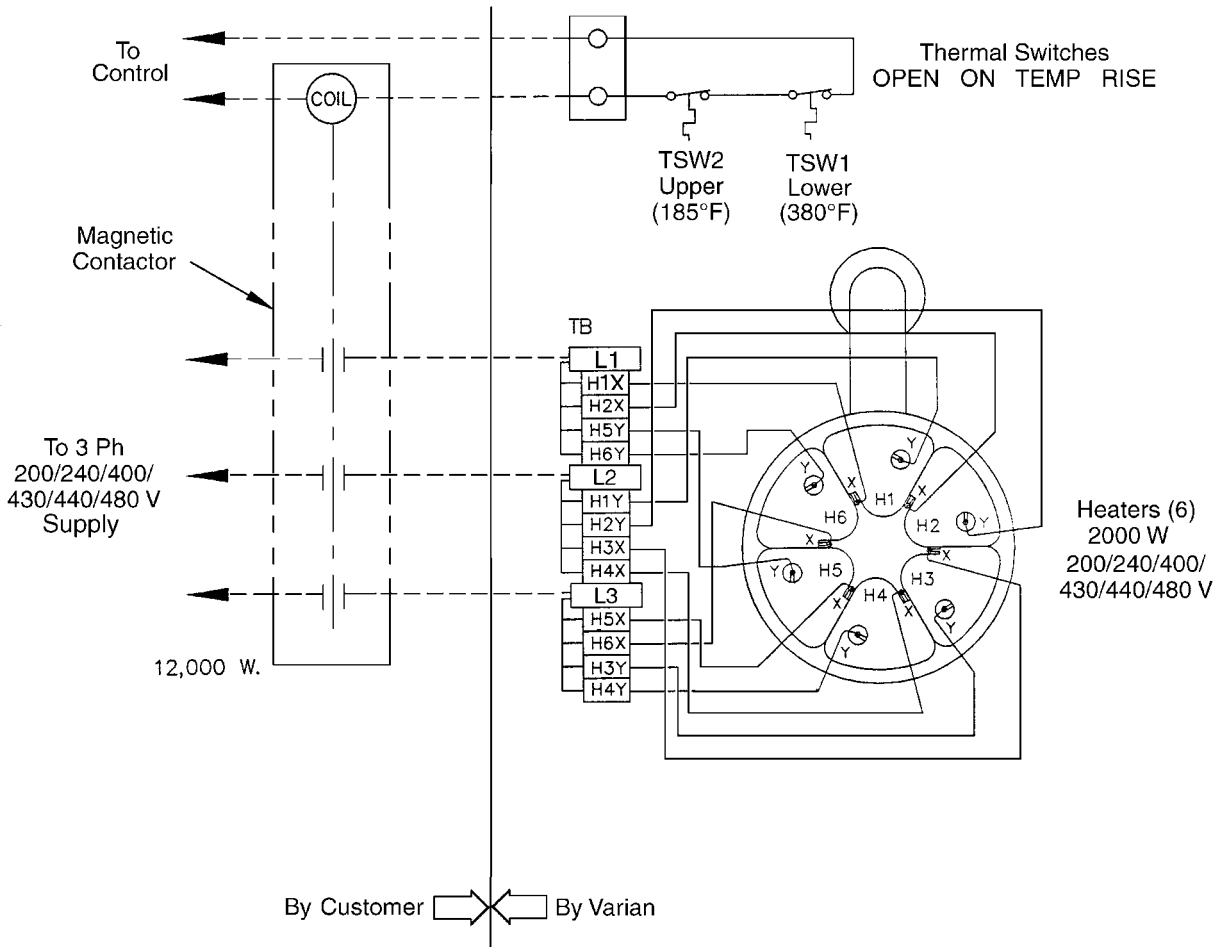

Element Resistance

- (+10% -5%)
- 200 V \cong 20 Ω
- 240 V \cong 29 Ω
- 400 V \cong 80 Ω
- 430 V \cong 93 Ω
- 440 V \cong 97 Ω
- 480 V \cong 115 Ω

R_{TOT} L1-L2/L2-L3/L3-L1

- 200 V \cong 7 Ω
- 240 V \cong 10 Ω
- 400 V \cong 26 Ω
- 430 V \cong 31 Ω
- 440 V \cong 32 Ω
- 480 V \cong 38 Ω

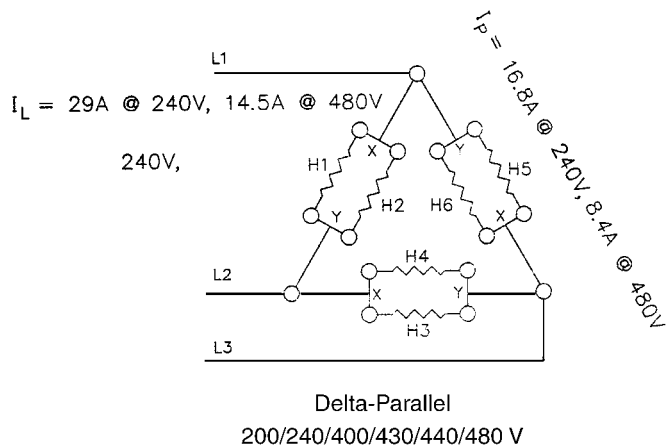

Figure 1-4. 200/240/400/430/440/480 V Wiring Diagram – HS-20 Diffusion Pump

Installation

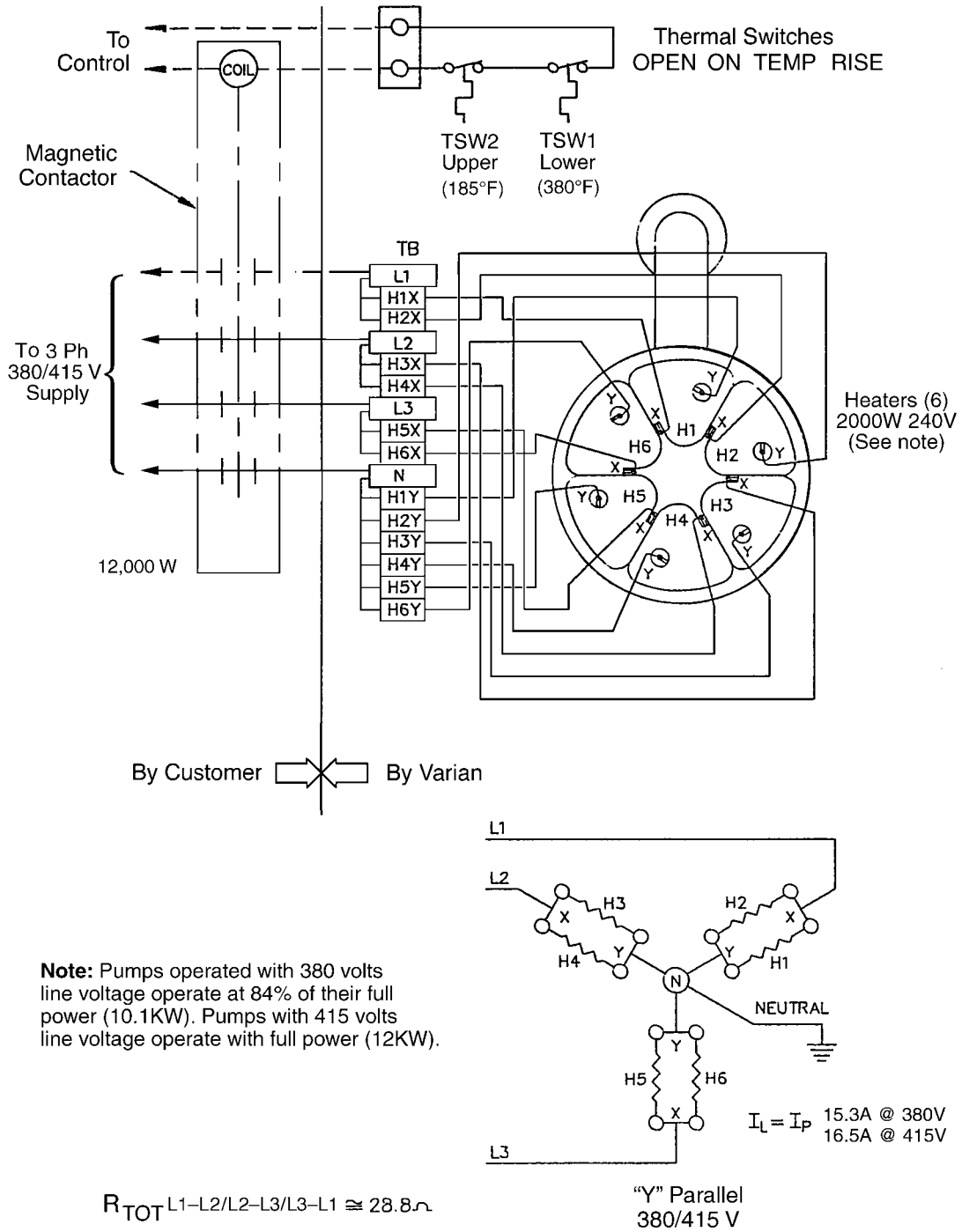

Figure 1-5. 380/415 V Wiring Diagram – HS-20 Diffusion Pump

WARNING

Pumps and their components are designed for vacuum service; they are not designed to be pressurized which could cause them to burst possibly expelling shrapnel at lethal velocities. Serious accidents have been caused by intentional pressurization of vacuum systems and their components. **Never pressurize any part of a vacuum system for test or any other purpose.** Always provide pressure relief when designing diffusion pumps into systems and ensure that pressure relief motion is limited to safe envelopes.

- a Confirm the vacuum ultimate pressure characteristics of the mechanical pump. This should closely approximate the value quoted in the manufacturer's data, if the mechanical pump is correctly installed, adjusted, and filled with clean oil. Pressure measurements should be made with a continuously indicating total pressure gauge, such as a thermocouple gauge. This test can be performed to evaluate either valved or unvalved systems. Connect the outlet or foreline of the diffusion pump to the inlet of the mechanical backing pump, using appropriate vacuum-tight connections.
- b In the case of a valved system, close the roughing valve and main isolation valve ahead of the diffusion pump. In the case of unvalved systems, the entire work chamber volume must be included in the test. Evacuate the entire system with the mechanical pump only. Let the mechanical pump reach an ultimate pressure in the system. This reading should approximate the value obtained in step a above (usually 10 to 50 microns (1.33 to 6.65 Pa)). If it does not, examine for leakage. If leakage is suspected, follow standard procedures for leak testing. These will depend on the type of vacuum gauges and/or leak detection equipment available. The most effective are Varian's helium leak detectors.

1-7 ADDING PUMP FLUID

WARNING

The risk of explosion in large pumps is increased by hydrocarbon oils, low fuel levels, or admitting atmospheric pressure during operation. Never operate diffusion pumps larger than 6 inches with hydrocarbon oils without a complete safety analysis for the specific system and application. Hydrocarbon oils are more prone to explode than synthetic silicone-based oils, similarly the larger the diffusion pump the greater the risk of explosion. Running the pump with low oil level causes overheating and the oil to be decomposed and become very toxic. Such decomposed oil and any residue from toxic/corrosive materials pumped may be present on the dipstick when the fluid level is measured.

NOTE

Fluids must be stored in clean, tightly closed containers and should be clearly identified in accordance with their type. Do not mix pumping fluids of different types and origins. Generally, it is not a good idea to mix used and new fluid for a pump charge.

Installation

- a. The recommended fluid charge for the pump is five U. S. quarts. The fluid charge will gradually be depleted through use, but the pump will continue to operate normally. When the charge is reduced to approximately 60% of the initial amount, the boiler temperature may begin to rise and under this condition the thermal switch is designed to open the heater circuit.
- b. This diffusion pump is furnished with fill and drain fittings with special Viton elastomer sealed plugs.
- c. If the pump is hot, wait until the pump has cooled then vent it to atmosphere. Remove the plug from the filling port of the pump and install the needed quantity of fluid up to the FULL COLD level indicator on the sight glass (see Figure 1-5). The fluid can also be poured in from the pump inlet or foreline.
- d. Replace the fill plug with a new Viton gasket. Tighten the fill plug using moderate torque (75 inch-pounds maximum). Lubricate the O-ring with pump fluid before installation.
- e. Once the pump is running, the oil level should be in the FULL HOT operating range as indicated on the sight glass assembly.

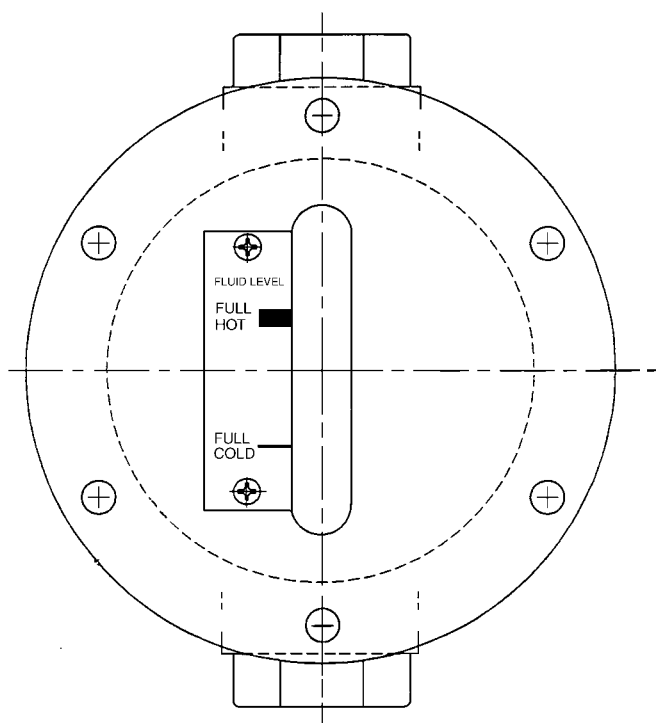

Figure 1-6. Sight Glass Assembly



NOTE

It is not recommended that Santovac 5 diffusion pump fluid be used with the HS-20.

SECTION II

OPERATION

During initial installation, the newly installed pump fluid may be subjected to a degassing process. This may result in foreline pressure fluctuations and "bursts". Such fluctuations are considered normal.

2-1 START-UP PROCEDURE

WARNING

The following conditions increase the risk of explosion:

- any air leaks into the system
- roughing through a hot diffusion pump may cause some hot hydrocarbon fluids to ignite or explode when exposed to air
- air release or admitting air to a pump with a hot boiler, permit a strong oxidizer to contact the hot pump oil
- high (above 1 micron (.133 Pa)) inlet pressure
- insufficient (or low level of) pump fluid
- operating pump without cooling water circulating to main water cooling coils
- operating pump with water trapped in quick cool coil
- foreign matter in the pumping fluid which changes its viscosity and obstructs flow passages

CAUTION

- Do not turn on the heater without fluid in the pump. This may ruin the heaters and damage the pump.
- Do not air-release the pump while the boiler is hot. Most diffusion pump fluids are heat-sensitive and will break down under these conditions.
- Do not operate the pump without the foreline baffle. This may cause a greater than normal fluid loss.
- Do not operate the pump for extended periods at an inlet pressure above 1 micron (.133 Pa). High pressure operation may cause excessive backstreaming.
- Do not operate the pump heater unless the cooling water is circulating. It will cause the pump and fluid to overheat.

- a. Evacuate the diffusion pump by means of the mechanical roughing pump to a pressure level below 0.5 Torr (66.5 Pa). The diffusion pump will not function unless the discharge pressure is less than the tolerable forepressure (approximately 0.5 Torr (66.5 Pa)).
- b. Turn on the cooling water supply to the pump body and check that adequate flow is provided by examining the amount of water discharged at the visual drain points.
- c. Switch on the power to the diffusion pump heater.

- d. Check inlet and forepressure performance by means of the system instrumentation.
- e. During operation, the gas load at the inlet of the diffusion pump should not exceed the maximum throughput capability of the pump. This means that the pressure at the inlet flange should not (except in transient conditions) exceed approximately 1×10^{-3} Torr (.133 Pa). During operation, the discharge or fore pressure must be below the specified tolerable forepressure.

2-2 SHUTDOWN PROCEDURE

 **WARNING**

Boiler temperatures reach 530°F (275°C) which can cause serious burns when touched. Always ensure surfaces have cooled near room temperature before touching them.

Air release or admitting air to a pump with a hot boiler, especially when it is under vacuum, permits a strong oxidizer to contact the hot pump oil and thereby increases the risk of an explosion.

 **CAUTION**

Do not operate the quick-cool coil when the pump is cold or out of service to prevent harmful collection of condensation on the boiler plate, heater, and heater terminals.

- a. Switch off the power to the diffusion pump heaters.
- b. Admit cooling water to the quick-cool coil if necessary and continue to circulate it until the pump body just above the boiler heat shield can be touched (approximately 130°F or 54°C). In valved systems which have tight inlet and foreline connections, it is possible to close valves to isolate the diffusion pump at inlet and discharge, to air-release the remainder of the system, shut off the heat to the diffusion pump, and stop the mechanical pump. With this method, the quick-cool coil does not have to be used. However, the water flow through the pump must be maintained until the boiler cools down below approximately 300°F (150°C).

SECTION III

MAINTENANCE

3-1 GENERAL

Diffusion pumps generally require little attention when correctly operated. However, it is advisable to perform some periodic checks to insure continued trouble-free operation. By simple preventive maintenance, costly down-time and cleaning procedures can be avoided. A day-to-day log of pump and system performance will indicate the condition of the pump and marked variations will show the need for corrective action.

3-2 PERIODIC INSPECTION

The frequency of inspection will depend on the type of system, its operation and utilization. The maximum interval between inspections is established on the basis of experience. It is recommended that the following items be regularly examined.



WARNING

High voltages (up to 480V) can kill. Always break the primary circuit to the power supply before starting to work on the heater and/or its wiring.

Make sure that the pump is at room temperature before attempting service. Serious burns can result if this Warning is not heeded.

Depending on system process, poisonous or corrosive compounds may be present when opening the fill or drain. Always wear appropriate gloves and clothing and use a self-contained breathing apparatus.

An explosion could occur if the fill or drain is opened when the pump is running or when it is hot. Check oil level only when the pump is cold.

- a. When the pump is cold, check the condition and level of fluid. These can be inspected by withdrawing a sample through the drain and by visually checking the level of fluid through the sight glass respectively. (Use new O-ring gaskets when replacing fill and drain plugs.) Slight discoloration of the fluid does not affect performance.
- b. Loss of the fluid can be caused by the following:
 1. incorrect air admittance procedures and/or admittance of excessive air or other gas to a hot pump
 2. inadequate water cooling
 3. continuous operation at inlet pressures above 10^{-3} Torr (.133 Pa), or
 4. failure to reinsert the foreline baffle in the pump assembly

Maintenance

- c. When the pump is cold, check that the heaters are bolted snugly to the boiler plate and that all heater terminal connections are tightly fastened inside the junction box.
- d. Check the total heater input and balance of load if a multi-phase heater is used.
- e. Check to insure that cooling water flow is unobstructed and not below specified quantities.

3-3 CLEANING

Complete cleaning of the pump may be periodically required because of the gradual deterioration of some pump fluids. Removal of the pump from the system is then necessary.

WARNING

If hazardous gas, vapors, chemicals, or combustible mixtures are pumped, sufficient quantities may exist during operation. This pump may contain decomposed and/or overheated pump oils or poisonous and/or corrosive process materials which are highly toxic and also can be an asphyxiant. Proper operation will not always ensure that all hazardous materials have been removed.

Diffusion pumps are typically cleaned with acetone, alcohol, or other solvents.

When heated, sprayed or exposed to high temperature equipment, these solvents become flammable and explosive, causing serious injury or death. **Do not use near a high-temperature source.** Ventilate working area with a blower and use in large, well-ventilated room. When heated or sprayed, solvents also become 4 to 5 times heavier than air and will flow down, settling in tanks, pits, and low areas, thus displacing air which can kill by asphyxiation. Use in a large, well-ventilated room. Use of a self-contained breathing apparatus may be necessary.

Acetone, alcohol, and other solvents are irritants, narcotics, depressants, and/or carcinogenics. Their inhalation and/or ingestion may produce serious effects. Prolonged or continued contact with the skin will result in absorption through the skin and moderate toxicity. Always ensure that cleaning operations are carried out in large, well-ventilated rooms, and wear eyeshields, gloves, and protective clothing.

WARNING

Acetone and other solvents degrade O-ring materials reducing their ability to hold a vacuum. Do not use solvents on O-rings. If necessary to clean O-rings, wipe with a lint-free, clean cloth or use a small amount of diffusion pump oil.

- a. Disconnect all water cooling lines and break the primary circuit supplying power to the pump heaters.
- b. Unbolt the inlet and foreline connections and remove the pump from the system.
- c. Drain the pump of all fluid.
- d. Remove the cold cap and jet assembly following the procedures outlined.
- e. Thoroughly clean the pump body interior using acetone followed by an isopropyl alcohol rinse. Dry with clean, dry, oil-free compressed air or heat gun.
- f. Thoroughly clean the jet assembly using acetone, wipe all surfaces with isopropyl alcohol, and dry with clean, dry, oil-free compressed air or heat gun.
- g. Install the jet and cold cap in the pump body. Ensure that the ejector is properly aligned with the foreline.
- h. Check the condition of the O-rings and replace them if necessary.
- i. Reinstall the pump in the system.

3-4 DISASSEMBLING AND REASSEMBLING THE COLD CAP (Refer to Figure 3-1)

- 1 To disassemble the cold cap:
 - a Remove the female coupling, nut, follower, and gasket located at the end of the cold cap water line on the outside of the pump.
 - b Remove the cold cap securing screw which secures the cold cap to the jet assembly.
 - c Lift out the cold cap.
- 2 To reassemble the cold cap:
 - a Insert the end of the cold cap water line into the cold cap port opening at the side of the pump before setting the cold cap on top of the jet assembly. Be careful not to damage the sealing surfaces.
 - b Replace the cold cap securing screw which secures the cold cap to the jet assembly. **Do not overtighten the screw.**
 - c Replace the gasket, the follower, the nut, and the female coupling to the side of the pump.

COLD CAP ASSEMBLY 84358301
(includes Rd Hd screw No. 10-32 x 1 in.
SST & hex nut No. 10-32 SST)

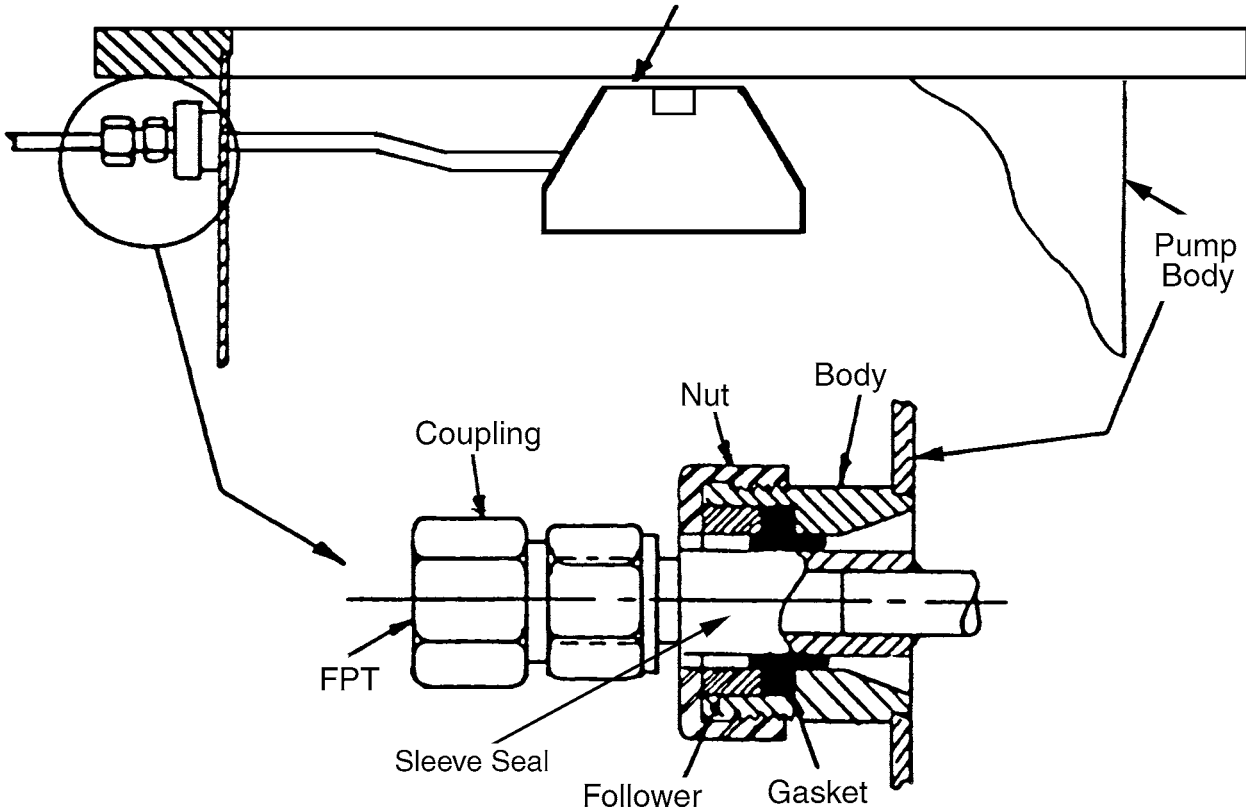

Figure 3-1. External Fittings – Cold Cap Assembly



NOTE

Customer to supply water tubing to be connected to coupling with FPT threads shown above.

3-5 JET ASSEMBLY

The HS-20 jet assembly consists of several subassemblies. The lower jet assembly consists of the jet base and stages 3 and 4. A jet shield is provided for the third stage jet. The second stage jet is secured to the central tube and forms a subassembly. A shield is provided for the second stage jet. The top of the central tube carries an orifice plug. The top jet spacer passes through this plug and by a spring-loaded coupling and tie rod secures all stages firmly.

All external and accessible internal surfaces of the jet assembly have been cleaned prior to shipment.

3-5-1 Disassembling the Jet Assembly (Refer to Figure 3-2)

- a Disassemble the cold cap water line feedthrough compression seals by removing the nut, the follower, and the gasket from the side of the pump.
- b Remove the cold cap securing screw and withdraw the cold cap assembly carefully. Be sure that the seal sleeves are not scored or otherwise damaged.
- c Firmly grasp the jet cap and unscrew it from the coupling assembly.
- d Remove the orifice plug.
- e Withdraw the central tube complete with second stage jet and jet shield.
- f Raise the lower jet assembly which consists of the third stage jet, the jet shield, the fourth stage jet, and the jet base.

3-5-2 Disassembling the Lower Jet Assembly

- a Remove the third stage shield.



NOTE

Before removing the securing screws in the following step, scribe a reference mark at the interface to assure that original holes are mated when reassembled.

- b Remove the securing screws between the third and fourth stage jets. Carefully preserve the screws. Be sure that the jet spacers are not damaged in handling.
- c Carefully remove the fourth stage jet from the jet base.
- d Clean all parts thoroughly.

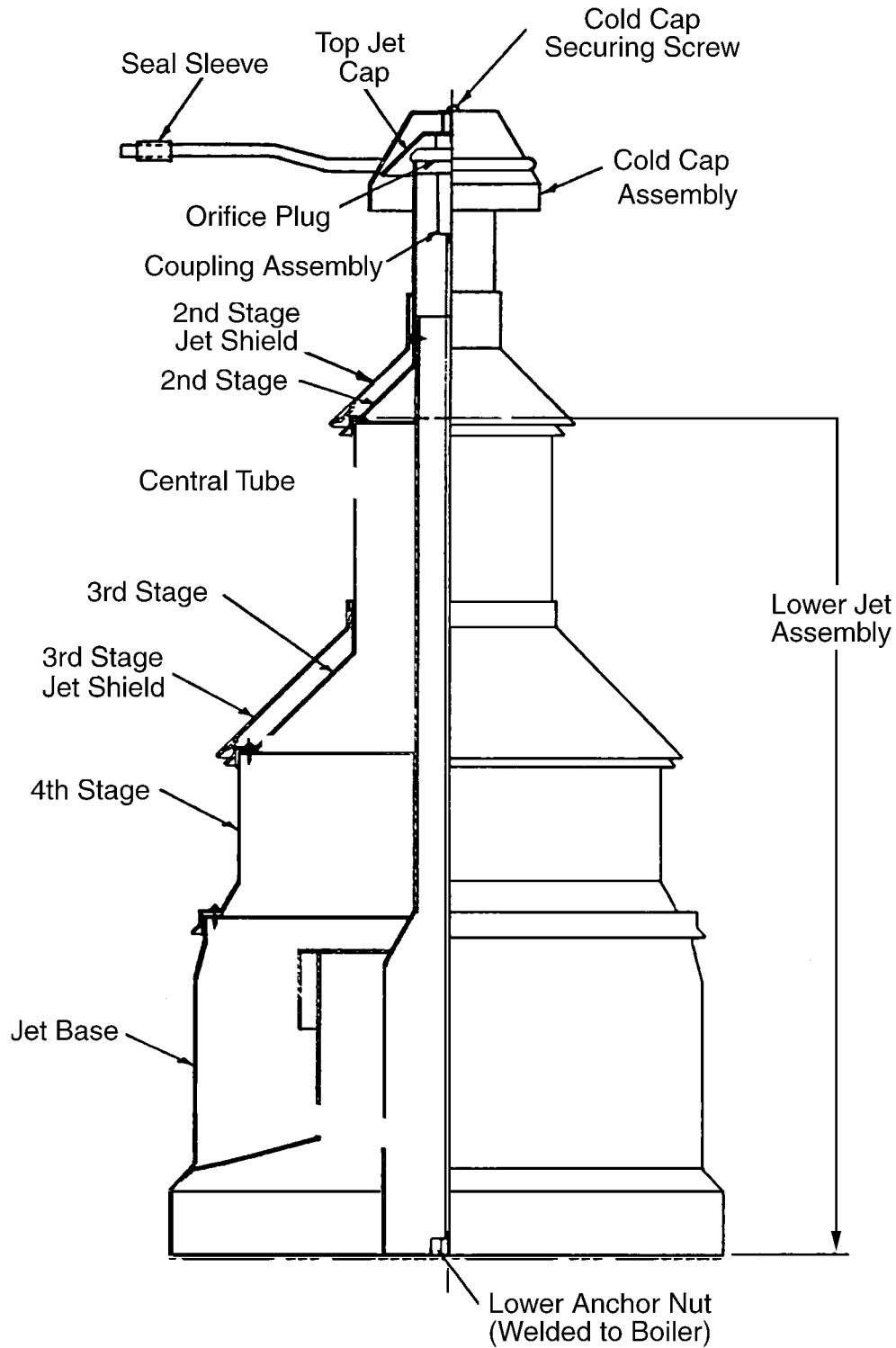

Figure 3-2. 20-inch Jet Assembly

3-5-3 Reassembling the Lower Jet Assembly

- a Carefully replace the fourth stage jet on the jet base.
- b Replace the third stage jet shield.



Before completing the following step, check that the gaps are even and tighten the screws uniformly and in a cyclic pattern. Jet spacings are preset at the factory and controlled by the spacers secured to respective stages.

- c Replace and tighten the securing screws between the third and fourth stage jets.

3-5-4 Reassembling the Jet Assembly



Before securing the jet assembly to the pump, check that the lower jet assembly is firmly seated on the pump with the ejector correctly positioned. For proper alignment, a pin is provided in the base of the pump; the large slot in the jet base must register on this pin.

- a Complete the steps in para. 3-5-1 in reverse order.



If the jet coupling became loose during step 3-5-1c, refer to Figure 3-3, Jet Coupling.

3-6 HEATER REPLACEMENT

The HS-20 diffusion pump heater array consists of six elements arranged to give as close a balanced load as practical over the three supply phases. The heater design employs a long, convoluted tubular heating element which is clamped directly to the boiler plate. A thin, stainless steel membrane with a number of elongated dimples, referred to as a crush plate, is placed in contact with the opposite side of the heating element. A stiff clamping plate forces the membrane against the heating element. When the clamping nuts are tightened, the dimples on the membrane are deformed at the points of contact with the heating element. This permits adjustment to dimensional variations in the boiler surface and/or in the thickness of the heating element.

During a replacement of heaters, only the crush plate and element must be purchased. These part numbers are listed on the Replaceable Parts List. The crush plate should be replaced if the heaters are removed for inspection or maintenance.

To replace the heaters, proceed as follows (refer to Figure 3-4).

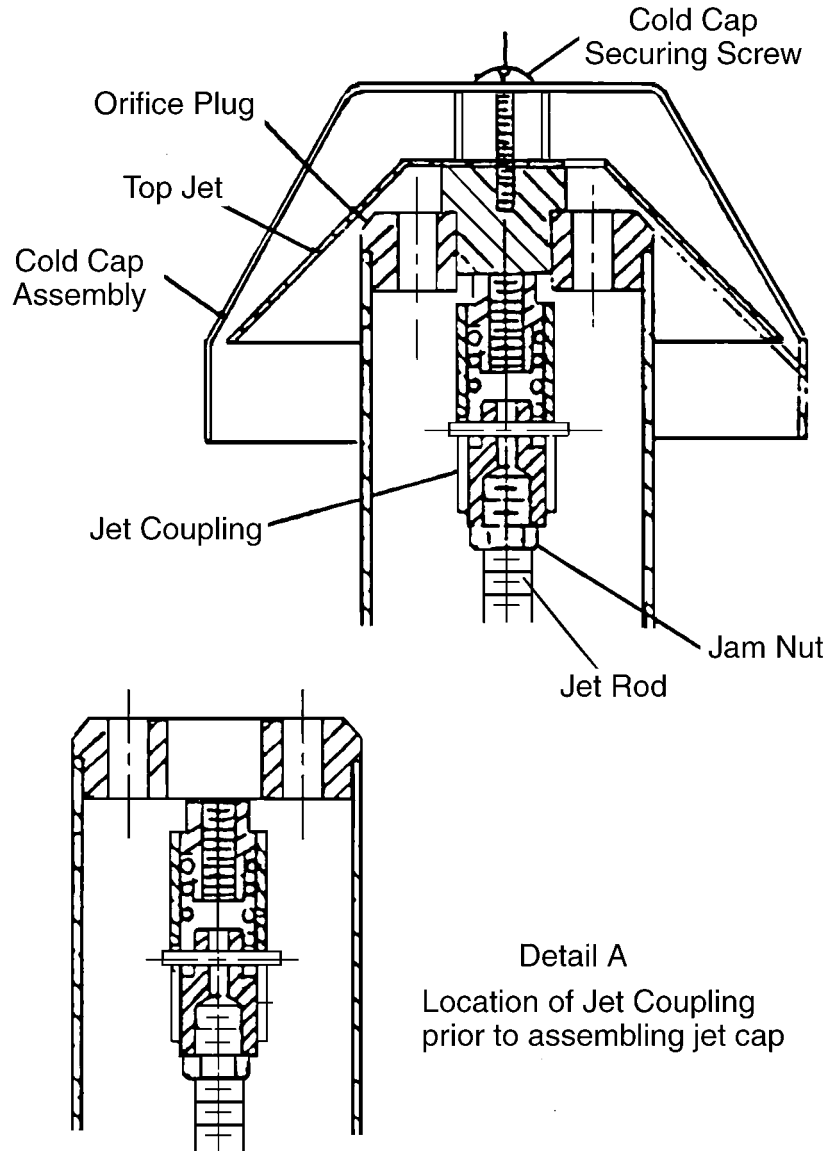

Note: If the jet coupling loosens from the jet rod during disassembly, position it so that the top of the jet coupling is flush with the bottom of the orifice plug.

Figure 3-3 Jet Coupling

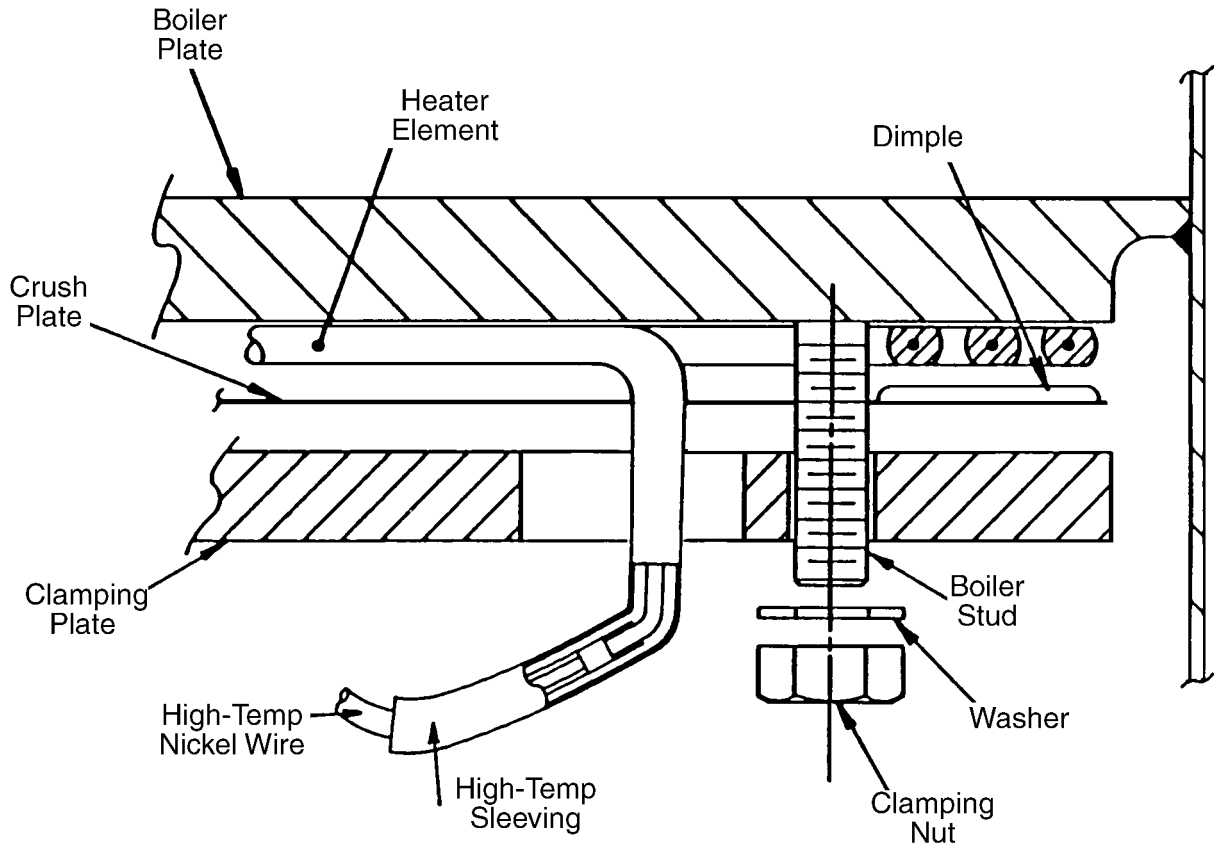

Figure 3-4. Heater Element Assembly



NOTE

Tighten clamping nuts to 250 in.-lbs.

▲ WARNING

High voltages (up to 480V) can kill. Always break the primary circuit to the power supply before starting to work on the heater and/or its wiring.

▲ CAUTION

Poor clamping resulting in inadequate thermal contact may result in reduced heater life and poor pump performance. Tighten nuts finger-tight on clamping plate, then gradually and evenly tighten them to 250 in-pounds of torque.

- 1 Determine which heater element has failed at the junction box, then disconnect the two corresponding leads from the terminal strip. Pull the leads out of the terminal box then out the elbow cover plate.
- 2 Remove the heater cover from the bottom of the diffusion pump. Move the insulation to expose the faulty heater(s).
- 3 Remove the nuts holding the clamping plate.
- 4 Lower the entire heating unit (heater element, clamping plate and crush plate) until it is off the mounting studs.
- 5 Apply an anti-seize compound such as FEL-PRO-C-5A or common milk of magnesia to the studs as needed.
- 6 Assemble the new unit (heater element, clamping plate, and crush plate).
- 7 Support the heating unit by the clamping plate, line up the holes with the boiler studs, and push the unit up against the boiler plate. Use two nuts finger-tight to hold it in place.
- 8 Screw on the remaining nut finger-tight, then tighten all nuts evenly up to 250 inch-pounds of torque.
- 9 Label the heater leads according to the schematic diagram, then run the wires into the conduit and up into the junction box. Connect the leads to the terminal strip then replace the elbow cover plate.
- 10 Replace the insulation and heater cover.

▲ CAUTION

Should it be necessary to use a new wire, it is important that no. 14 stranded nickel wire with high-temperature insulation is used. If copper or copper-plated wire is used, they will oxidize rapidly because of the high temperature and the terminals will overheat and fail.

3-7 REPLACEABLE PARTS

The following is a list of replaceable parts for the Varian HS-20 Diffusion Pump.

| Part Number | Description |
|-------------|---|
| 84358301 | Cold cap assembly (includes No.10-32 SST Rd Hd screw and No. 10-32 hex nut) SST |
| 660811494 | Cold cap gasket (see Figure 3-2) |
| F2622001 | Cold cap follower (brass) |
| 75786001 | Cold cap nut |
| 622445026 | Cold cap female coupling, ½-inch OD tube x ⅜-inch FPT, Imperial Flexfitting No. 66-FL |
| L6367301 | Sprint coupling |
| 84350301 | Jet coupling assembly |
| 84889301 | Foreline baffle assembly |
| F6097301 | Sight glass service kit (includes glass tube, O-rings, and fittings; valves not included) (for pumps built prior to October 1994) |
| F1755301 | Sight glass assembly (includes seal valve, glass tube, removable bracket, cover for sight glass assembly, and fittings) (for pumps built prior to October 1994) |
| 77261001 | Threaded plug, fill and drain |
| K9050001 | Upper thermal switch, 185°F |
| K9050002 | Lower thermal switch, 390°F |
| 656118114 | Nickel wire, No. 14 AWG |
| 648056329 | Nickel lug for No. 14 AWG |
| 647320025 | Heater element with leads (2000W, 200V) |
| 647320020 | Heater element with leads (2000W, 240V or 380V) |
| 647320035 | Heater element with leads (2000W, 400V) |
| 647320040 | Heater element with leads (2000W, 430V) |
| 647320045 | Heater element with leads (2000W, 440V) |
| 647320030 | Heater element with leads (2000W, 480V) |
| K7108001 | Crush plate (replace with each heater) |
| K7107001 | Clamping plate |
| L6514001 | Insulation for heaters – Cerablanket 0.50 inch thick |
| 84497001 | Heater cover plate |
| L9223001 | Sight glass (for pumps built after October 1994) |
| K0377165 | O-ring kit; includes: 1 butyl ASA inlet flange O-ring (84349002) 1 butyl ASA foreline flange O-ring (660893432) 8 Viton fill and drain O-rings (660892213) 1 Sight glass O-ring (660892240) 1 Graphite sight glass gasket (L9228001) |
| 695472008 | DC-702 diffusion pump fluid (one-gallon container) |
| 695474008 | DC-704 diffusion pump fluid (one-gallon container) |
| 695475008 | DC-705 diffusion pump fluid (one-gallon container) |

SECTION IV

TROUBLESHOOTING

4-1 LEAKAGE

Analysis of general operational experience with diffusion pumps indicates that certain locations are more prone to the incidence of leaks. The following locations should be checked first if leakage is the suspected cause of poor system performance.

- a. Inlet and foreline connections.
- b. Drain and fill plugs.
- c. Other compression fittings, such as high-vacuum gauges in the system.
- d. Threaded connections, such as a foreline gauge.

4-2 OUTGASSING

High-vacuum systems, even without external leakage, can have high gas loads due to outgassing from internal surfaces or processes. The pressure in the system is a result of gas load divided by pumping speed ($p = Q/S$). If the gas load (Q) exceeds the maximum throughput capability of the diffusion pump, the diffusion pump will not function and the pumping action will essentially be due to the mechanical backing pump.

To estimate the gas load, isolate the system from all pumps after evacuation and measure the rate of pressure increase. The gas load can be estimated as follows:

$$Q = \frac{V \times \Delta P}{\Delta t}$$

where V is the isolated volume, ΔP is the pressure rise, and Δt time period of measurement.

4-3 POOR PUMP OR SYSTEM PERFORMANCE

Before proceeding with a program of step-by-step troubleshooting, check the performance and accuracy of the vacuum gauges used on the system. Table 4-1 shows common faults, and lists the probable cause and corrective actions to correct for poor performance.

Table 4-1 Troubleshooting

| Fault | Probable Cause | Corrective Action |
|-------|----------------------------------|------------------------------------|
| | Leaks in system, virtual or real | Locate and repair. |
| | High process gas load | Measure gas load, eliminate cause. |
| | System dirty | Clean system to reduce outgassing. |

Troubleshooting

Table 4-1 Troubleshooting (Cont'd)

| Fault | Probable Cause | Corrective Action |
|----------------------------|--|---|
| Poor ultimate pressure | Contaminated pump fluid | Examine and clean pump; replace fluid. |
| | Low heat input | Check voltage. Check for continuity, burned-out element, poor thermal contact. |
| | Inadequate cooling water flow | Check water pressure. Check tubing for obstructions and backpressure. |
| | Excessive or too cold cooling water | Check temperature. Adjust flow. |
| | High forepressure | Check for leak in foreline, poor mechanical pump performance, breakdown of mechanical pump fluid. |
| | Water in quick-cool coil | Check and remove cause. |
| | Low heat input | Check heaters. |
| Inlet pressure surges | Low fluid level | Add fluid. |
| | Malfunctioning pump assembly. Improperly located jets. Damaged jet system. | Check and repair or replace. |
| | Incorrect heater input | Check and correct. |
| | Fluid outgassing | Condition fluid by operating the pump for a few hours. |
| High chamber contamination | Leak in system ahead of pump inlet | Check and correct. |
| | Forepressure too high | Check for leak in foreline, poor mechanical pump performance, breakdown of pump fluid, and incorrect valve operation. |
| | Prolonged operation at high throughput at pressure above 10^{-3} Torr | Review procedures. |
| Pump will not start | Improper system operation and air release procedures | Review procedures. |
| | Safety circuits and/or protective prevent contactor from staying closed | Check utilities, flow devices switches, interlocks. Check thermostat operation. |