

PHOENIXTM

temperature monitoring QCM

user guide

2nd generation

Contents

4	Chapter 1: Phoenix™ Sensor at a Glance
5	Phoenix™ Subcomponents
5	Phoenix™ Base Subcomponents
6	Chapter 2: Eon-LT™ System Components
6	Eon-LT™ and Accessories
10	Chapter 3: Eon-LT™ Inputs & Outputs
10	Eon-LT™ Connectors
12	Eon-LT™ Inputs
12	Eon-LT™ Outputs
13	Chapter 4: Hardware Connections
13	Preparing Phoenix™ for Chamber
16	Chamber Installation
17	Connecting to Phoenix™
19	Chapter 5: Electronics Connections
19	Connecting Phoenix™ and Eon-LT™
20	Connecting Eon-LT™ to PC
22	Chapter 6: Troubleshooting
22	Troubleshooting
23	Chapter 7: Specifications
23	Hardware
24	Electronics

Contents

25	Appendix A: Phoenix-Eon-LT™ System
25	Phoenix-Eon-LT™ System Configuration
26	Appendix B: Safety, Handling, & Support
27	About Phoenix™
27	Inspection & Initial Setup
27	Warranty
29	Appendix C: Tooling Factor
30	Appendix D: Phoenix™ Dimensions
31	Index

Phoenix™ at a Glance

1

This guide discusses assembly and proper care and handling of Phoenix™ (2nd generation) sensor with temperature control.

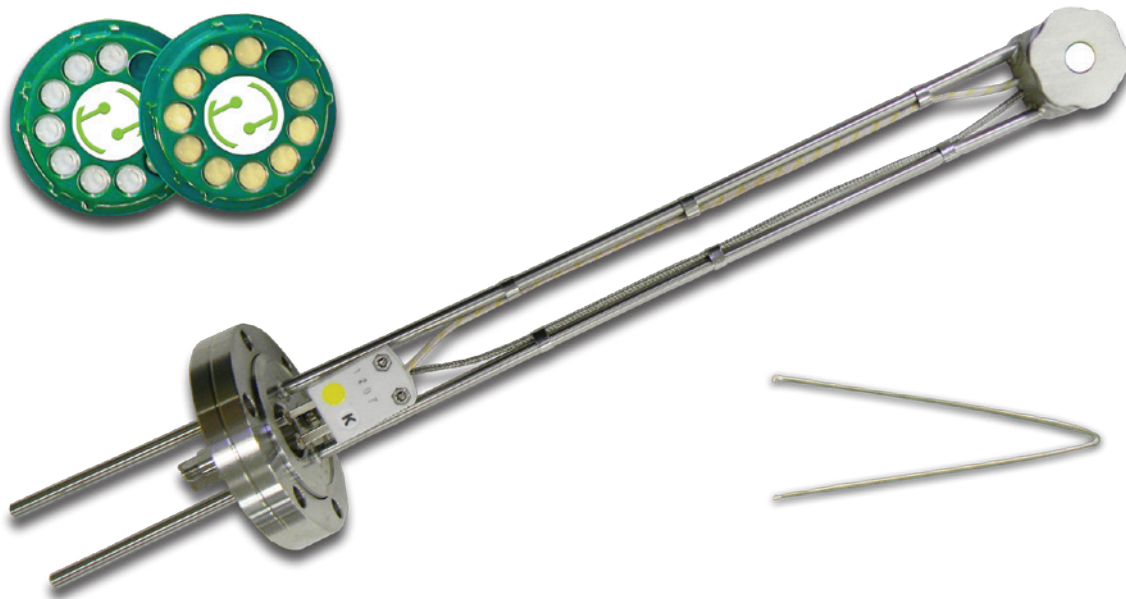

INSPECT PRODUCT CONDITION ON ARRIVAL Examine Phoenix™ for any signs of physical damage that may have occurred during shipping. Make sure that the tamper-evident labels are intact. Before shipping, Phoenix™ was calibrated and tested by Colnatec to meet the highest quality standards. It is important that you take a few minutes to inspect the product to ensure that your equipment was not damaged or otherwise tampered with during transit.

Phoenix™ Subcomponents

The sensor head features many sub-components. The usage of these components will be detailed in later sections.

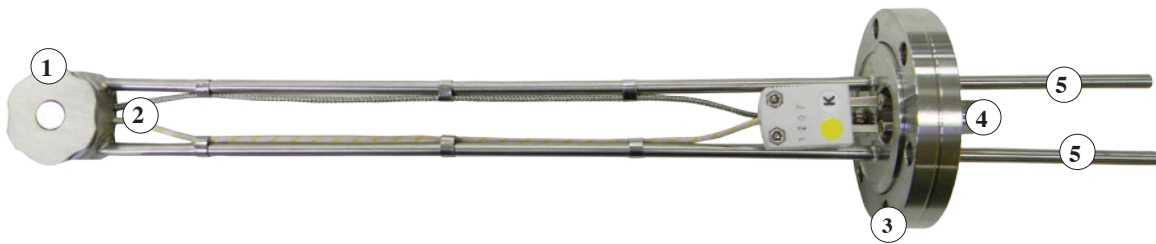

1. **Sensor Head**
Houses quartz crystal

2. **Crystal Control Cables**
Transmits control and monitoring data between sensor head and controller

3. **Flange**
Acts as nearly air-tight barrier sealing sensor head in chamber

4. **Thermocouple Connector**
Measures temperature around sensor head

5. **Cooling Tubes**
For cooling sensor head

Phoenix™ Base Subcomponents

The sensor head features many base sub-components. The usage of these components will be detailed in later sections.

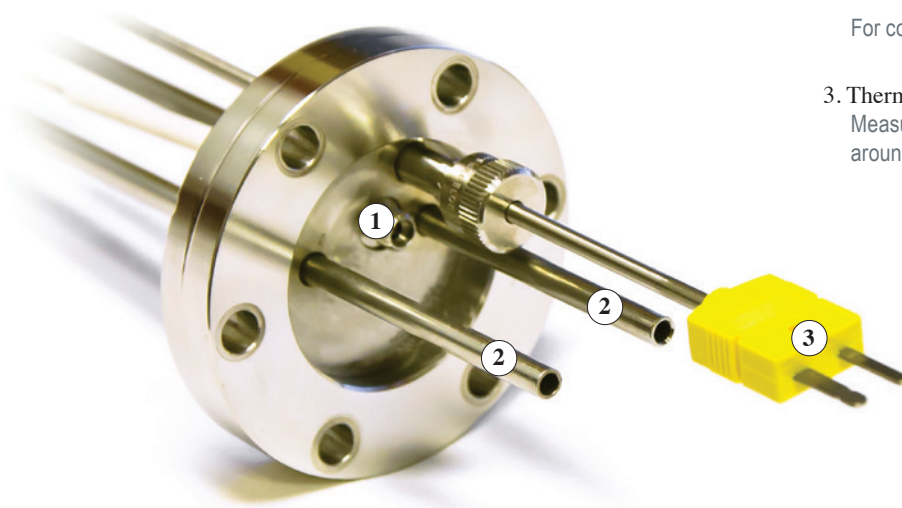

1. **SMA Coaxial Connection**
For crystal frequency measurement

2. **Cooling Tubes**
For cooling the sensor head

3. **Thermocouple**
Measures temperature around sensor head

Eon-LT™ System Components

2

Eon-LT™ and Accessories

Phoenix-Eon-LT™ ships with a variety of accessories.

Eon-LT™. A temperature measuring film thickness monitor that surpasses conventional monitors that are blind to thermal changes of the crystal. The combination of frequency and temperature measurement allows unprecedented accuracy in real-time rate and film thickness monitoring.

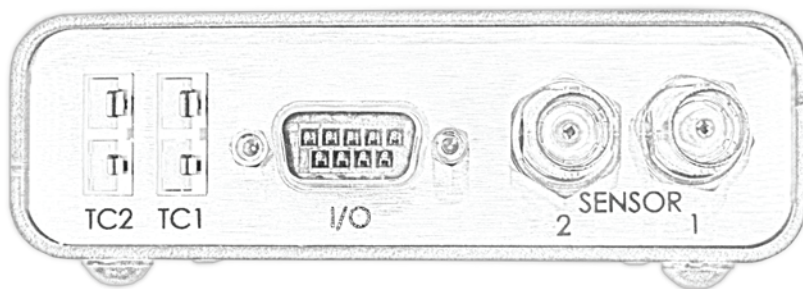

While Eon-LT™ Monitor is compatible with industry standard crystal sensors, it was also specifically created to be paired with Colnatec's Phoenix™ in combination with AT or RC™ 6 MHz crystals to accomplish a degree of precision never before imagined in the world of thin film.



INSPECT PRODUCT CONDITION ON ARRIVAL Examine Eon-LT™ for any signs of physical damage that may have occurred during shipping. Make sure that the tamper-evident labels are intact. Before shipping, Eon-LT™ was calibrated and tested by Colnatec to meet the highest quality standards. It is important that you take a few minutes to inspect the product to ensure that your equipment was not damaged or otherwise tampered with during transit.



WARRANTY LABEL If the warranty label has been tampered with, “VOID” will appear where the warranty label was originally placed. If this is visible at the time of arrival, it is important that you contact Colnatec immediately after receiving the product.

Power supply and cable. Input 100-200 VAC, 50/60Hz, 2 A. Output 24V, 3.75 A, 90W Max.



RS-232 extension cable. Male-to-female serial cable.

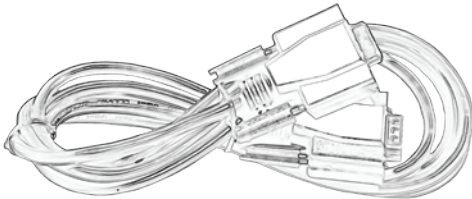

USB to RS-232 adapter. Connects RS-232 cable and PC.



External oscillator. Replaces the Eon-LT™ internal oscillator.



Phoenix-Eon-LT™ quick reference guide. Instructs user in quickly assembling and integrating Eon-LT™ into existing system.

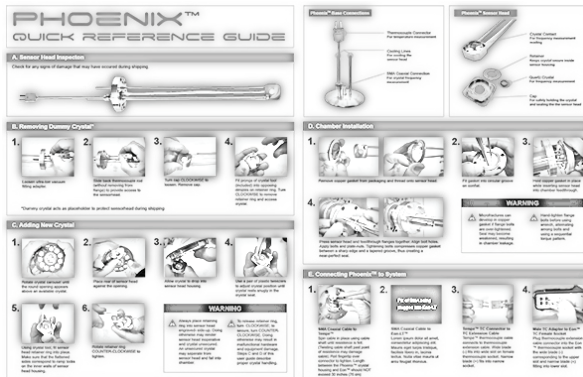

Software CD. Contains Eon™ software suite, manuals, quick reference guides, and other helpful resources.



Eon-LT™ Inputs & Outputs

3

This guide describes Eon-LT™ controller with temperature control (3rd generation).

Eon-LT™ Connectors

Eon-LT™ Front

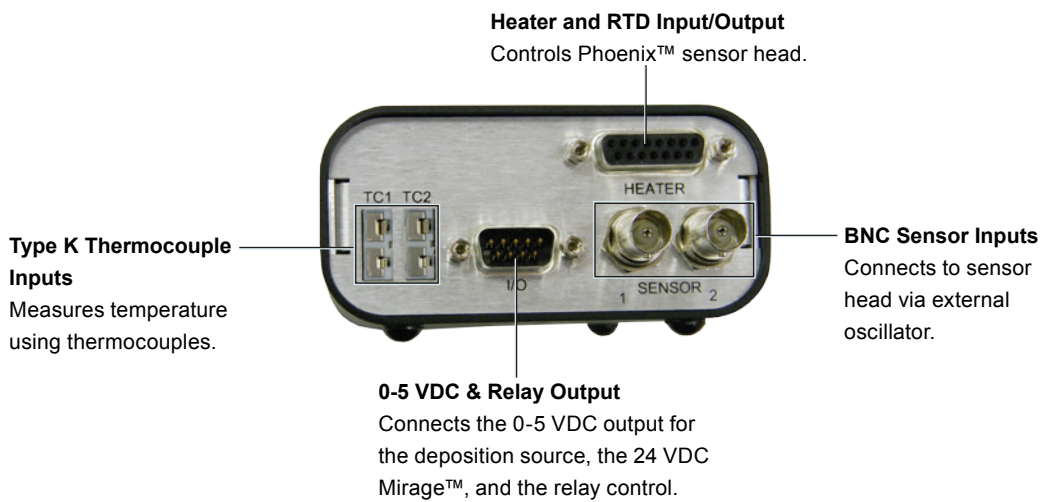

Eon-LT™ Back

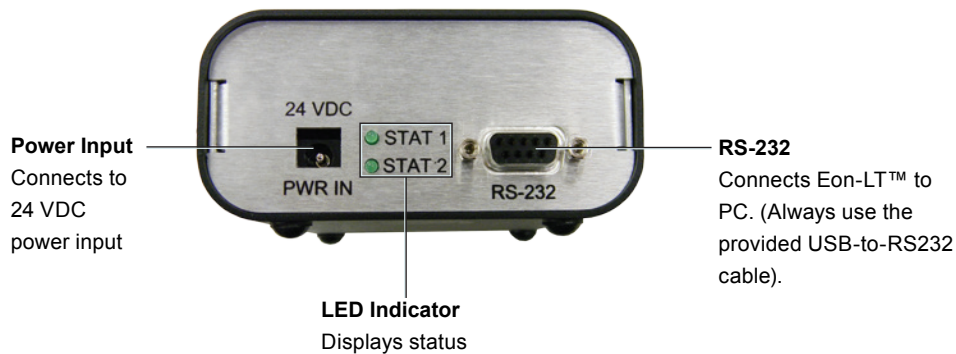



WARNING Make sure the correct hardware is used with Eon-LT™ inputs and outputs. See proper setup procedures in this manual and in the Phoenix-Eon-LT™ quick reference guide.



WARNING Only the provided power supply should be used with Eon-LT™. Using an alternative power supply may damage product and void warranty.

Eon-LT™ Inputs

The Eon-LT™ utilizes four (4) inputs. **Make sure the correct hardware is used with these inputs.**

Power

Only the provided power supply should be used with Eon-LT™. Not doing so will cause hardware damage to Eon-LT™ that will not be covered by warranty. Ensure that the power supply has a 24 VDC.

ComPort

Connect an RS232 cable to this port. Always use the provided USB to RS232 cable.

BNC Sensor Inputs

Eon-LT™ has a built in oscillator. (Colnatec also offers an external oscillator for purchase). The cable between Eon-LT™ and the crystal should remain as short as possible to avoid noise. The advisable maximum acceptable length for this is one (1) foot or 30 cm.

TC Connection

Eon-LT™ uses a thermocouple probe to measure the temperature of the sensor head.

Eon-LT™ Outputs

The Eon-LT™ utilizes one (1) output. Make sure the correct hardware is used with this output.

DB9 Connector

Connects the two SPST relays and two source outputs.

Hardware Connections

4

Preparing Phoenix™ for Chamber

Removing Mock Crystal

1. Turn cap COUNTER CLOCKWISE to loosen and remove.

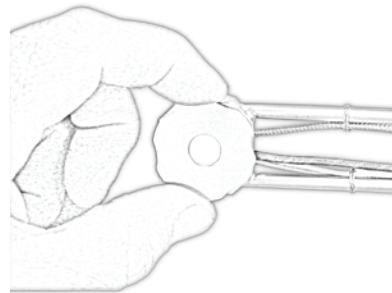

2. Flip cap over to access crystal retainer ring. Turn retainer ring COUNTER CLOCKWISE until loose.

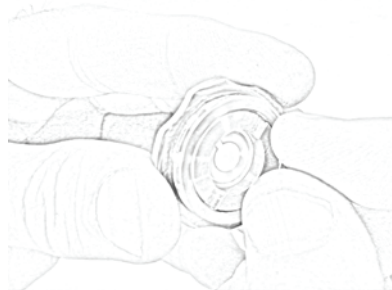

3. Remove retainer ring to access mock crystal.

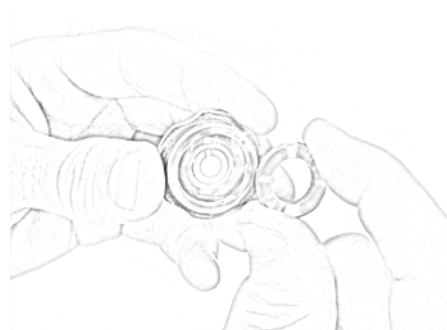

4. Remove mock crystal from sensor head cap.

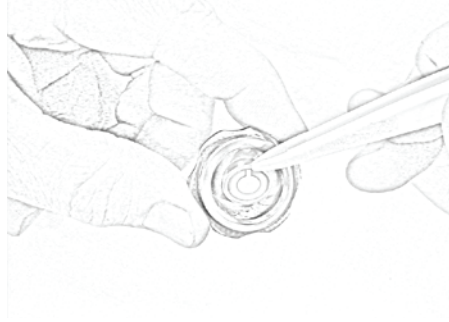

Adding New Crystal

1. Rotate crystal carousel until the round opening appears above an available crystal.

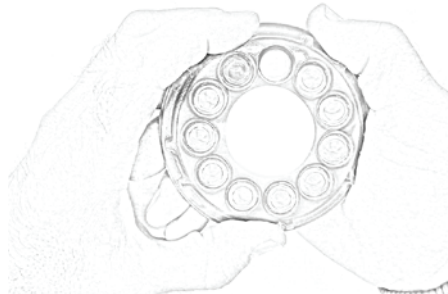

2. Place rear of sensor head against the opening.

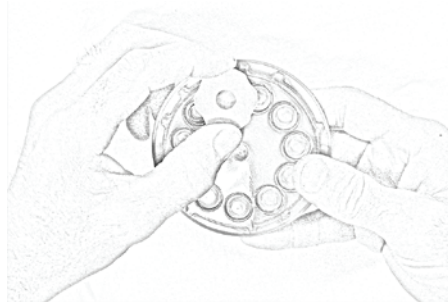

3. Flip crystal carousel and allow crystal to drop into sensor cap housing.

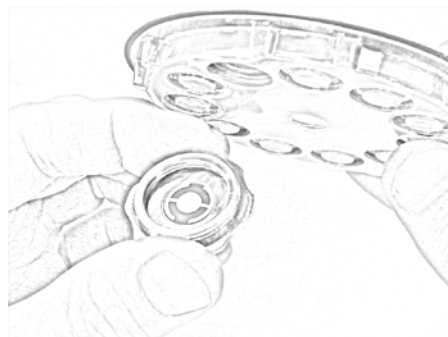

4. Use a plastic prod to adjust crystal position until crystal rests snugly in the crystal seat.

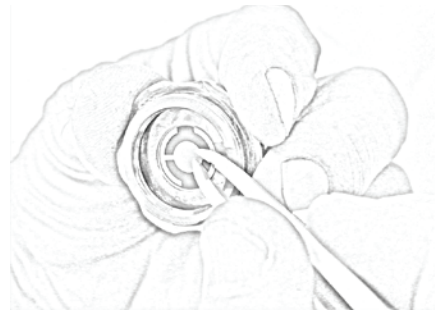

5. Place the threaded side of the retainer ring onto the corresponding threads of the sensorcap. Tighten the retainer ring by turning the ring CLOCKWISE.

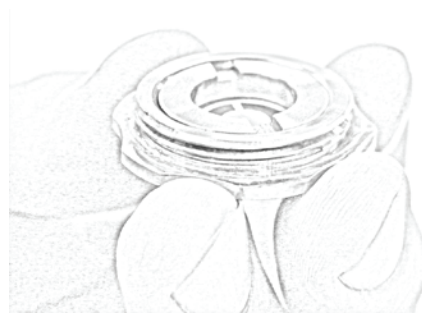

6. Place cap onto corresponding threads of crystal compartment. Turn CLOCKWISE until secure.

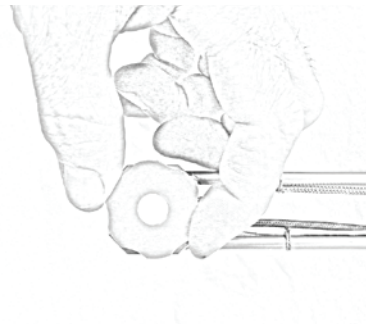

Chamber Installation

1. Remove copper gasket from packaging and thread onto sensor head.

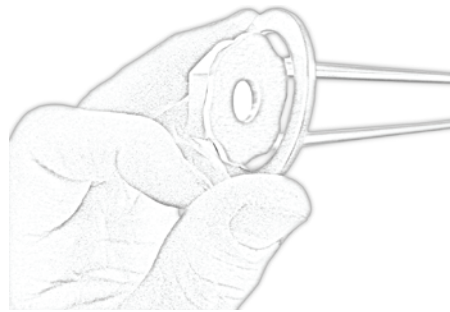

2. Fit gasket into circular groove on Conflat.

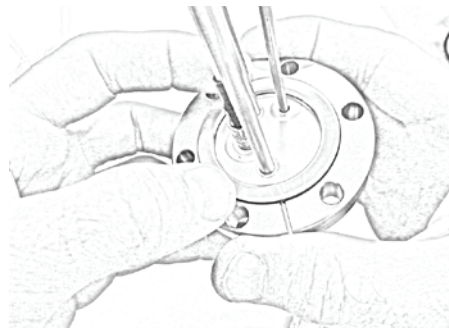

3. Hold copper gasket in place while inserting sensor head into chamber feedthrough.

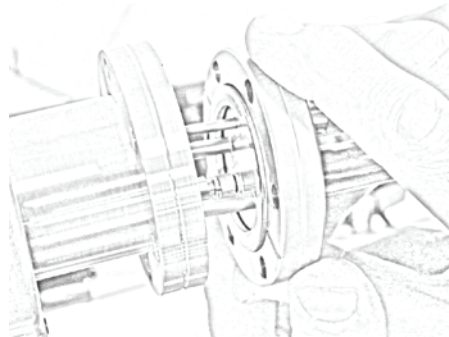

4. Press sensor head and feedthrough flanges together. Align bolt holes. Apply bolts and plate-nuts. Tightening bolts compresses copper gasket between a sharp edge and a tapered groove, thus creating a strong seal.

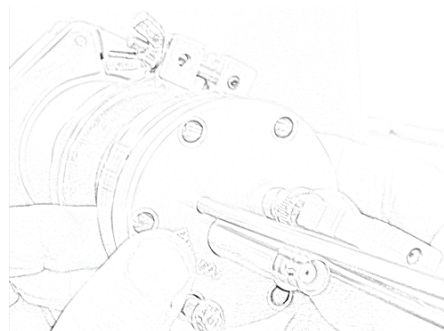

5. Apply bolts and plate-nuts.
Tightening bolts compresses copper gasket between a sharp edge and a tapered groove, thus creating a near-perfect seal.

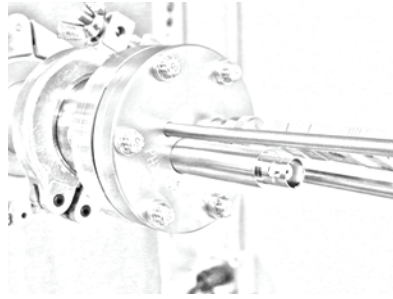

6. **Access to Base Connections**
Once the bolt ring has been tightened into place, user will have open access to all of the base connections on the Phoenix™. (See Page 5 for a complete list of all base connections and their purpose).

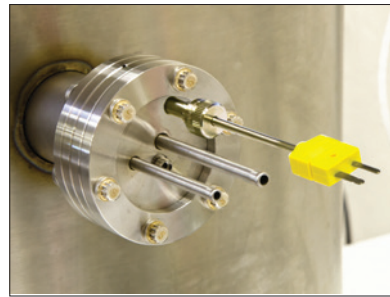

WARNING Hand-tighten flange bolts before using wrench, alternating among bolts and using a sequential torque pattern.

Over-tightening flange bolts may cause microfractures to develop in copper gasket. Seal may become weakened, resulting in chamber leakage.

Connecting to Phoenix™

1. **BNC Coaxial Cable to Position Phoenix™**
Spin cable in place using cable shaft until resistance is felt. (Twisting cable shaft past point of resistance may damage cable). Roll fingertip over connector to tighten.

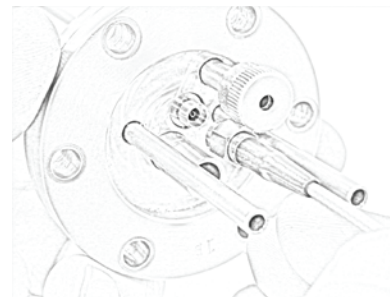

2. Connect Phoenix™ to Eon-LT™

Connect BNC extension cable to SMA, which then connects to the BNC adapter cable using the provided BNC union. Then, connect the other end of the BNC extension cable to the Eon-LT™ coaxial input (either sensor 1 or 2).

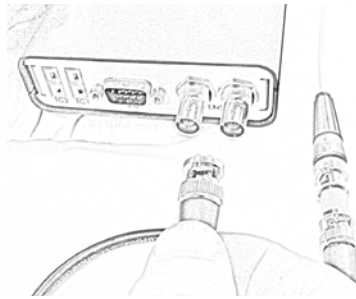

3. Connect Phoenix™ TC Connector to TC Extension Cable

Connect Phoenix™ TC cable to TC extension cable. Wide blade (-) fits into wide slot on female thermocouple socket. Narrow blade (+) fits into narrow socket.

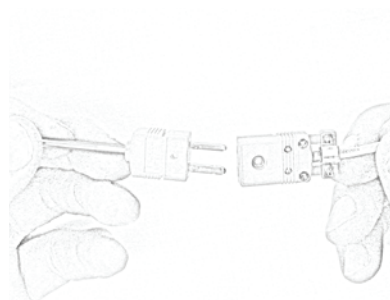

4. Male TC Adapter to Eon-LT™ TC Female Socket

Plug thermocouple extension cable connector into the Eon-LT™ TC socket with the wide blade (-) corresponding to the upper slot and narrow blade (+) fitting into lower slot.

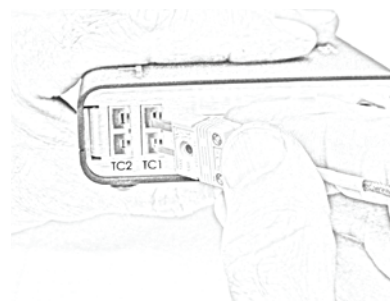

WARNING Length between the Phoenix™ crystal compartment and the Eon-LT™ should NOT exceed 30 inches (76 cm) to avoid erratic noise levels in oscillation reading.

Electronics Connections

5

Connecting Phoenix™ to Eon-LT™

1. **BNC Coaxial Cable to Eon-LT™**
Slide coaxial connector onto BNC Sensor Input 2.

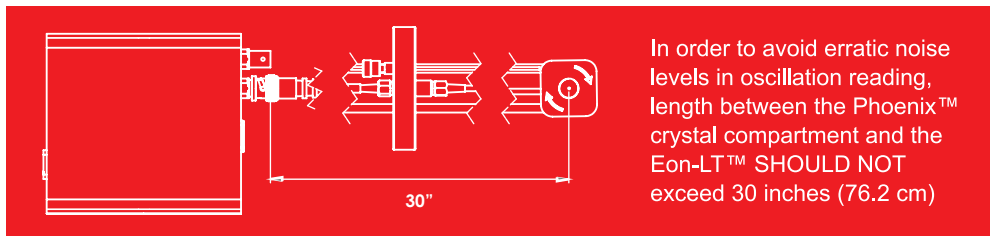
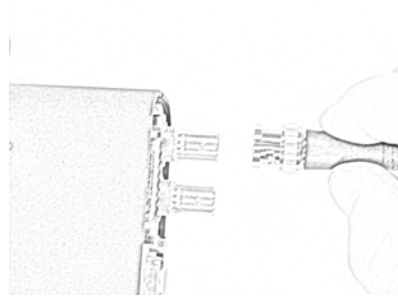

WARNING The cable between Eon-LT™ and the crystal should remain as short as possible to avoid noise. If using the internal oscillator alone the advisable maximum acceptable length for the cable is one (1) foot (30 cm).



WARNING DO NOT allow operating temperature to exceed 500°C. Equipment damage will likely result.

Connecting Eon-LT™ to PC

1. Install Eon-LT™ Software onto PC

Insert the accompanying Eon-LT™ software CD into disc drive. Follow prompts to install software onto PC.

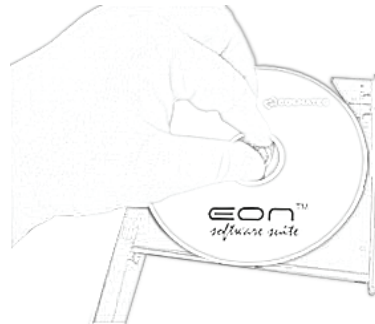

2. RS-232 to Eon-LT™

Plug RS-232 connector into female serial port on rear panel. Tighten integrated screws.



3. RS-232 cable to USB Adapter

Plug the other end of the RS-232 cable into the USB-to-RS-232 adapter. Tighten integrated screws.

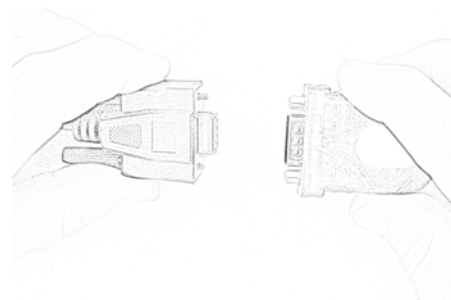

4. Plug USB-to-RS-232 Adapter into PC

Plug USB-end of the USB-to-RS-232 adapter into PC.



5. Connect Power to Eon-LT™

Plug Eon-LT™ power adapter into AC outlet. Then plug DC connector into the Eon-LT™.

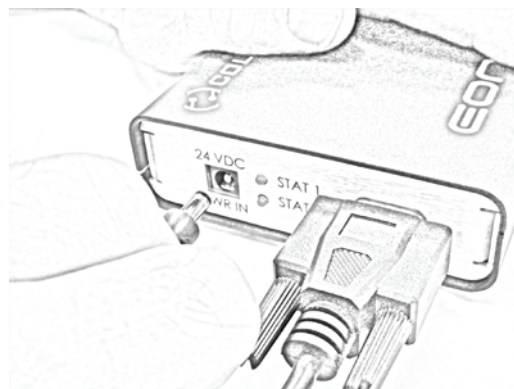

6. Start Eon-LT™ Software

Start Eon-LT™ software and follow the First Start setup procedure described in the Eon-LT™ User Manual (available on the Eon-LT™ software CD).

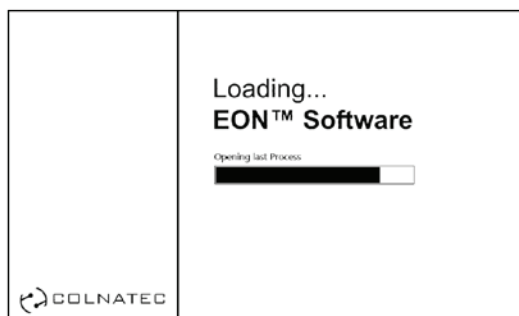

WARNING If drivers are already installed, simply update the drivers when installing software.

Use only the provided USB cable.

Ensure that the software has been fully installed before connecting the USB drivers.

Fully reboot the computer after the software installation to prevent drivers issues.

Troubleshooting

6

Symptom	Cause	Solution
Broken Crystals	Crystal not seated properly.	Make sure that the crystal is seated properly in the cap and retainer to avoid mechanical stress on the crystal when temperature rise.
Weak Crystal Reading	Contact spring may have become bent.	If the crystal contact spring has become bent, it may no longer apply even pressure against the crystal. Assuring the conical spring is concentric with the body may resolve this issue.
Software Issues	Various possible causes.	See Eon-LT™ Controller manual for software troubleshooting guide.

Because it is a scientific instrument, the Phoenix™ sensor head should be treated with care. In the event of any difficulties please contact Colnatec's Customer Support. Excessive tinkering or fiddling may result in greater damage to the unit. If you cannot resolve an issue, please contact support@colnatec.com, or call **(480) 634-1449**.



WARNING Do not attempt to repair electrical problems. Tampering with the Phoenix™ electrical systems may result in electrical fire, increased interference in crystal measurement, and damaged ceramic insulators.

Specifications

7

Hardware

Flange Size	KF40, KF-50, CF275
Head Orientation	180° Concentric
Flange to Crystal	(designed to specification)
Cooling Tube	3/16 Diameter
Component Materials	Sensor Body 304 SS nickel alloy contact springs, 304 SS screws
	Type K Thermocouple 304 SS Sheath, .125"
	Crystal Cable Stainless steel-covered high-temp wire; nickel plated copper wire conductor
	Crystal Cable Stainless steel-covered high-temp wire; nickel plated copper wire conductor
Dimensions	Length 4" to 24" depending on customer requirements
	Cross Section Able to be passed through a 2.75" ConFlat port
Operating Temperature	40-500° C
Vacuum Rating	1x10 ⁻⁵ Torr
Material	AIS304 SS
Part Number	CNT-TMP-2000 Rev. 3.1 (B)

Electronics

Temperature Range	0-500°C
Crystal	Standard 14 [mm]
Frequency Measurement Connection	SMA Coaxial

Phoenix-Eon-LT™ System

Phoenix-Eon-LT™ System Configuration

Rendering illustrates basic connections of Phoenix-[^]Eon-LT™ system.

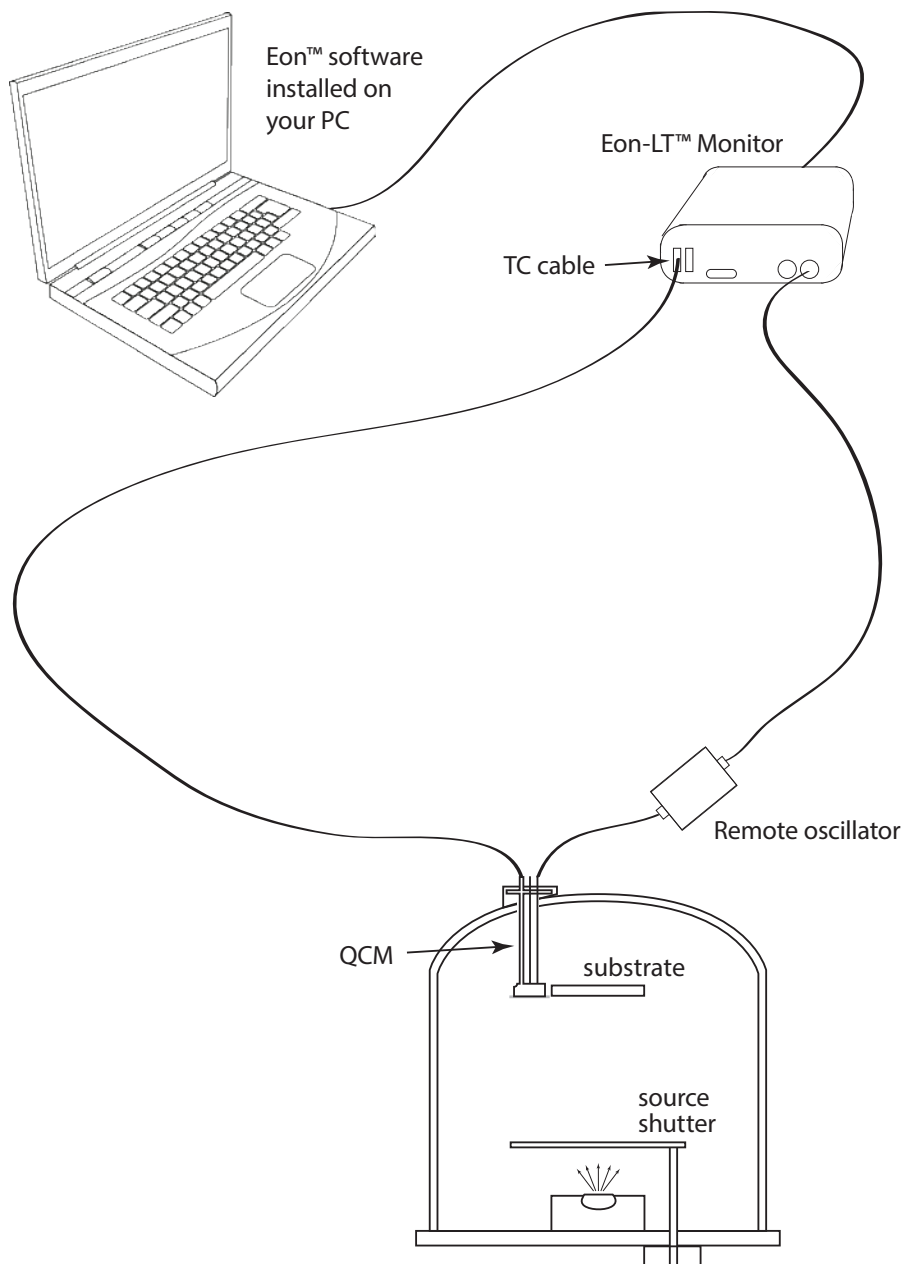

Safety, Handling, & Support

B

Appendix



WARNING All electrical components are to be considered extremely dangerous if tampered with in any way. Colnatec is not liable for any injury resulting from product misuse, modification, or disassembly.



WARRANTY LABEL If the warranty label has been tampered with, “VOID” will appear where the warranty label was originally placed. If this is visible at the time of arrival, it is important that you contact Colnatec immediately after receiving the product.



EXAMINE YOUR NEW PHOENIX™ FOR ANY SIGNS OF PHYSICAL DAMAGE. Before shipping, your Phoenix™ was calibrated and tested by Colnatec to meet the highest quality standards. It is important that you take a few minutes to inspect the product to ensure that your equipment was not damaged or otherwise tampered with during transit.

About Phoenix™

Temperature fluctuation is the most significant cause of frequency drift in crystals. Traditional sensor heads address this with water-cooling. While many manufacturers advise that crystal temperature be kept “around 20°C”, their sensors have no means of measuring temperature.

Real-world application has shown that a standard water-cooled sensor can experience a 20°C discrepancy within as little as 10 minutes during high-rate deposition. In an industry of nanometer measurements, this level of variance will easily result in significant inaccuracy within thickness reading.

The Phoenix™ was designed to address this flaw, by employing an embedded thermocouple that may be read with a simple thermocouple meter. When integrated with the Eon-LT™ film thickness monitor or controller, both temperature and frequency are automatically graphed alongside the corresponding rate and thickness values on a personal computer, allowing for real-time correction and accuracy up to .001 Hz.

Inspection and Initial Setup

Examine Phoenix™ for any signs of physical damage. Also, make sure that the tamper-evident labels are intact. In order to ensure safe, correct operation of your Phoenix™, please follow the step-by-step instructions presented in the Phoenix™ Quick Start guide included with your product.

Warranty

Phoenix™ is warranted to the original purchaser to be free of any manufacturing-related defects for one year from the date of purchase. Colnatec reserves the right to repair or replace the unit after inspection.

Contact Colnatec Support

511 W. Guadalupe Road, Suite 23
Gilbert, AZ 85233
(480) 634-1449
support@colnatec.com
www.colnatec.com

Tooling Factor

$$\text{Tooling \%} = \left(\frac{dc}{ds} \right) \cdot 100$$

$$\text{Tooling \%} = \left(\frac{dc}{ds} \right)^2 \cdot 100 \cdot \left(\frac{\cos \phi_s}{\cos \phi_c} \right)$$

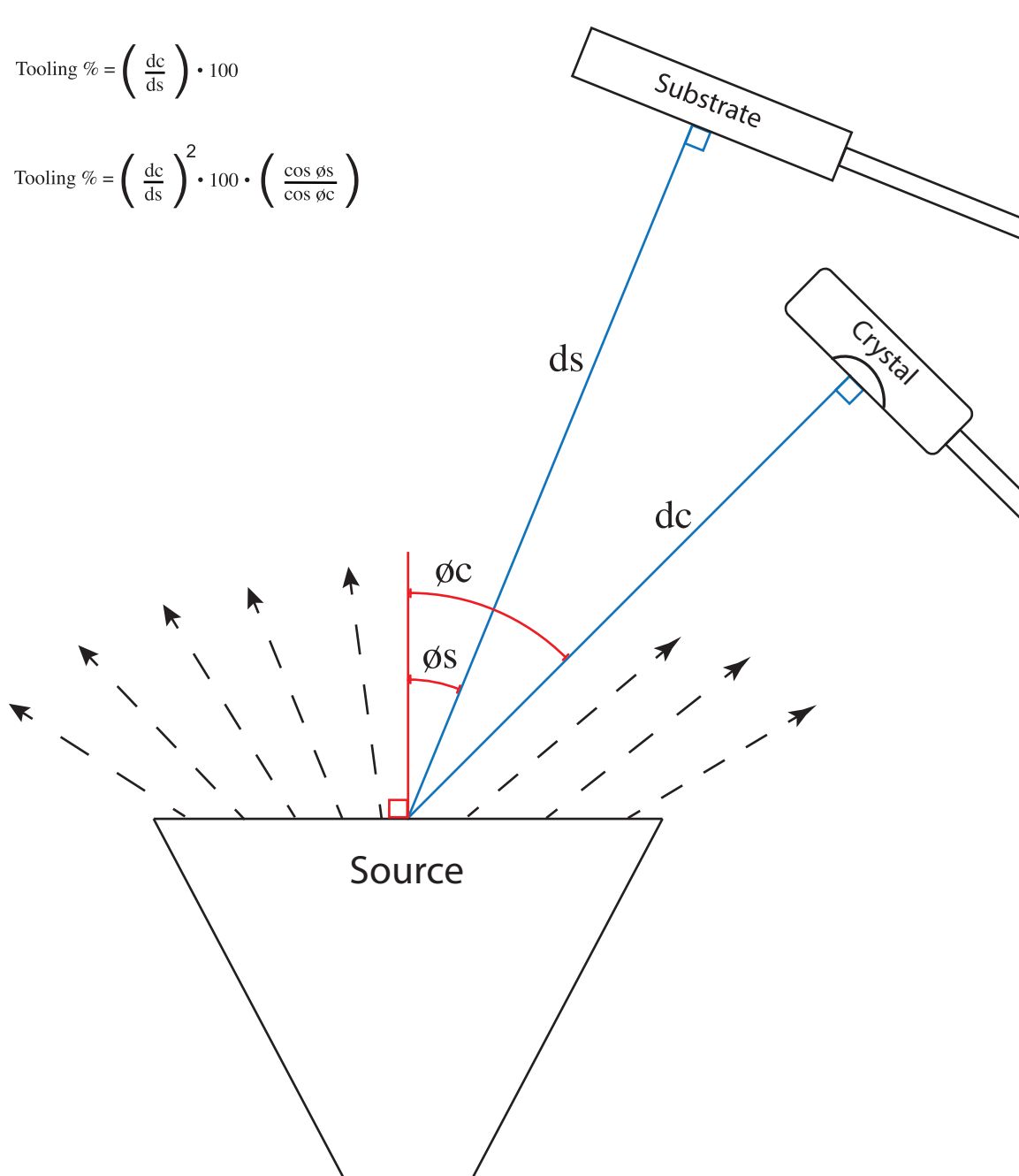

Phoenix™ Dimensions

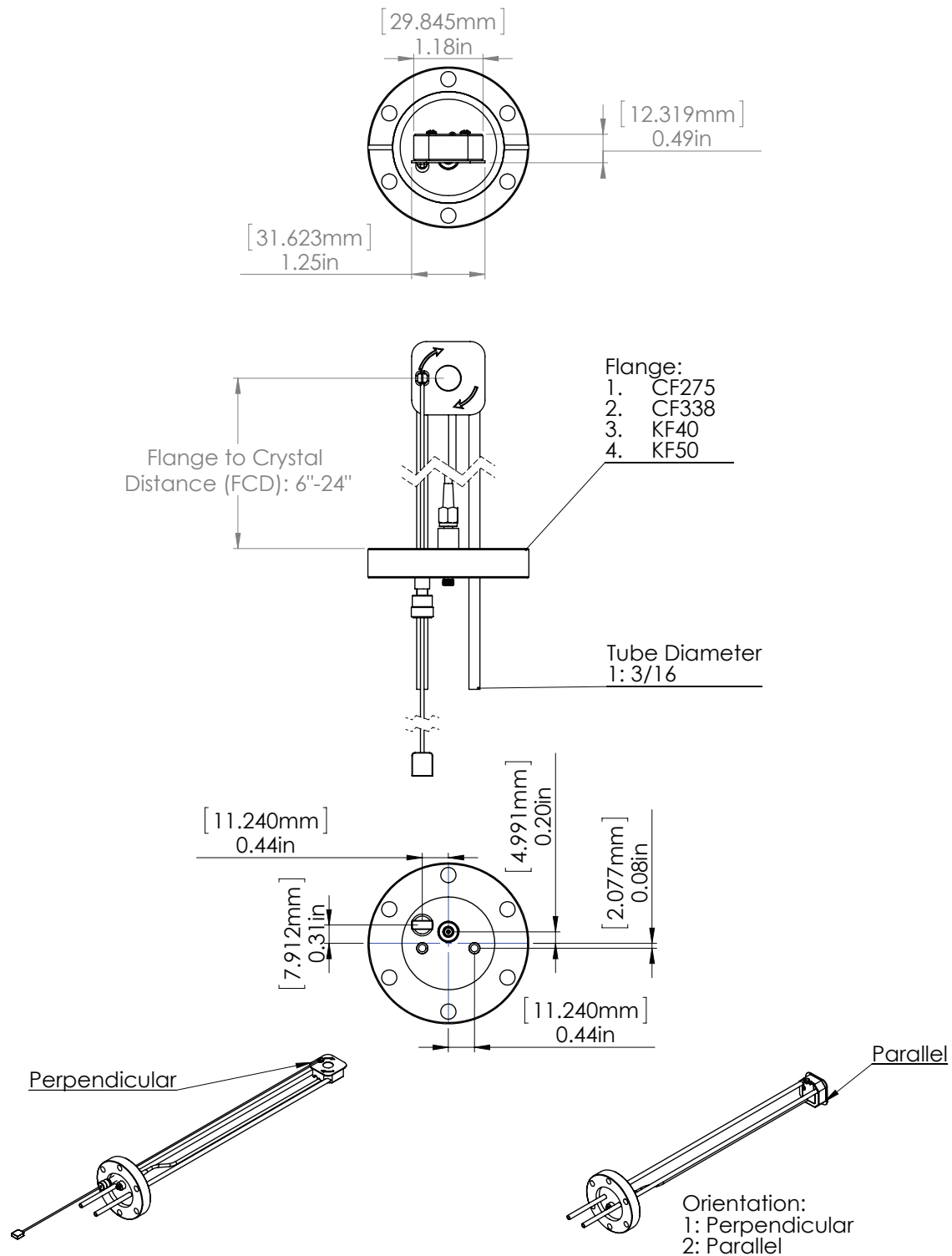

Index

B

BNC Coaxial Cable 17, 19, 31

C

Chamber Installation 16, 31

Compressed Air 31

ConFlat 23, 31

Connections 13, 14, 15, 16, 17, 18, 19, 20, 21, 31

Connector 5, 12, 18, 31

Connect Power 21

Contact Colnatec 28, 31

Controls 5

Cooling Lines 31

Copper gasket 16, 17, 31

Copper Gasket 31

Crystal 5, 13, 14, 15, 22, 23, 24, 27, 31, 32

Crystal Frequency 23, 31

D

DB-15 Connector 31

Dimensions 23, 30, 31

E

Eon-LT™ 4, 5, 6, 7, 8, 9, 10, 11, 12, 13, 18, 19, 20, 21, 22, 23, 25, 26, 27, 28, 29, 31

Eon™ Software 20, 21, 31

F

Flange 17, 19, 20, 23, 31

G

Getting Started 31

H

Hardware 13, 14, 15, 16, 17, 18, 23, 31

I

Initial Setup 27, 31

Inputs & Outputs 10, 11, 12, 31

M

Mock Crystal 13

P

PC 8, 10, 20, 32

Phoenix™ 4, 5, 6, 10, 13, 17, 18, 19, 22, 27, 30

Power supply 8

R

Retainer ring 13, 15

RS-232 cable 8, 20

S

Subcomponents 5, 32

Support 22, 26, 27, 28, 32

System Configuration 25, 32

T

Tooling Factor 29, 30, 32

Troubleshooting 22, 32

U

USB Adapter 20, 32

W

Warranty Label 26, 32

© Copyright 2014 Colnatec

All information contained within this technical manual and accompanying pages are copyright of Colnatec. All rights reserved. It is a breach of copyright if this technical manual is copied, distributed, or reproduced, in whole or part, using any means whatsoever, without the prior written approval of Colnatec.

Colnatec gives no condition or warranty, expressed or implied, about the fitness of this technical manual or accompanying hardware product. Colnatec reserves the right to make changes to this technical manual or accompanying hardware or design without notice to any person or company.

Colnatec shall not be liable for any indirect, special, consequential or incidental damages resulting from the use of this technical manual or the accompanying hardware or design whether caused through Colnatec's negligence or otherwise.

September 2014
2nd generation