

User Manual

Infra-820 / 840

Cabinet SmartCard Handle, Network version



Designed and manufactured by Austin Hughes

Legal Information

First English printing, October 2002

Information in this document has been carefully checked for accuracy; however, no guarantee is given to the correctness of the contents. The information in this document is subject to change without notice. We are not liable for any injury or loss that results from the use of this equipment.

Safety Instructions

Please read all of these instructions carefully before you use the device. Save this manual for future reference.

- Unplug equipment before cleaning. Don't use liquid or spray detergent; use a moist cloth.
- Keep equipment away from excessive humidity and heat. Preferably, keep it in an air-conditioned environment with temperatures not exceeding 40° Celsius (104° Fahrenheit).
- When installing, place the equipment on a sturdy, level surface to prevent it from accidentally falling and causing damage to other equipment or injury to persons nearby.
- When the equipment is in an open position, do not cover, block or in any way obstruct the gap between it and the power supply. Proper air convection is necessary to keep it from overheating.
- Arrange the equipment's power cord in such a way that others won't trip or fall over it.
- If you are using a power cord that didn't ship with the equipment, ensure that it is rated for the voltage and current labeled on the equipment's electrical ratings label. The voltage rating on the cord should be higher than the one listed on the equipment's ratings label.
- Observe all precautions and warnings attached to the equipment.
- If you don't intend on using the equipment for a long time, disconnect it from the power outlet to prevent being damaged by transient over-voltage.
- Keep all liquids away from the equipment to minimize the risk of accidental spillage. Liquid spilled on to the power supply or on other hardware may cause damage, fire or electrical shock.
- Only qualified service personnel should open the chassis. Opening it yourself could damage the equipment and invalidate its warranty.
- If any part of the equipment becomes damaged or stops functioning, have it checked by qualified service personnel.

What the warranty does not cover

- Any product, on which the serial number has been defaced, modified or removed.
- Damage, deterioration or malfunction resulting from:
 - Accident, misuse, neglect, fire, water, lightning, or other acts of nature, unauthorized product modification, or failure to follow instructions supplied with the product.
 - Repair or attempted repair by anyone not authorized by us.
 - Any damage of the product due to shipment.
 - Removal or installation of the product.
 - Causes external to the product, such as electric power fluctuation or failure.
 - Use of supplies or parts not meeting our specifications.
 - Normal wear and tear.
 - Any other causes which does not relate to a product defect.
- Removal, installation, and set-up service charges.

Regulatory Notices Federal Communications Commission (FCC)

This equipment has been tested and found to comply with the limits for a Class B digital device, pursuant to Part 15 of the FCC rules. These limits are designed to provide reasonable protection against harmful interference in a residential installation.

Any changes or modifications made to this equipment may void the user's authority to operate this equipment. This equipment generates, uses, and can radiate radio frequency energy and, if not installed and used in accordance with the instructions, may cause harmful interference to radio communications.

However, there is no guarantee that interference will not occur in a particular installation. If this equipment does cause harmful interference to radio or television reception, which can be determined by turning the equipment off and on, the user is encouraged to try to correct the interference by one or more of the following measures:

- Re-position or relocate the receiving antenna.
- Increase the separation between the equipment and receiver.
- Connect the equipment into an outlet on a circuit different from that to which the receiver is connected.

Notice : The changes or modifications not expressly approved by the party responsible for compliance could void the user's authority to operate the equipment.

IMPORTANT NOTE: To comply with the FCC RF exposure compliance requirements, no change to the antenna or the device is permitted. Any change to the antenna or the device could result in the device exceeding the RF exposure requirements and void user's authority to operate the device.

Before Installation

- It is very important to locate the equipment in a suitable environment.
- The surface for placing and fixing the equipment should be stable and level or mounted into a suitable cabinet.
- Make sure the place has good ventilation, is out of direct sunlight, away from sources of excessive dust, dirt, heat, water, moisture and vibration.
- Position the equipment with respect to related facilities.

InfraBox Installation

- Suggest the installation at the rear top mounting of cabinet
- M6 screws set not provided.

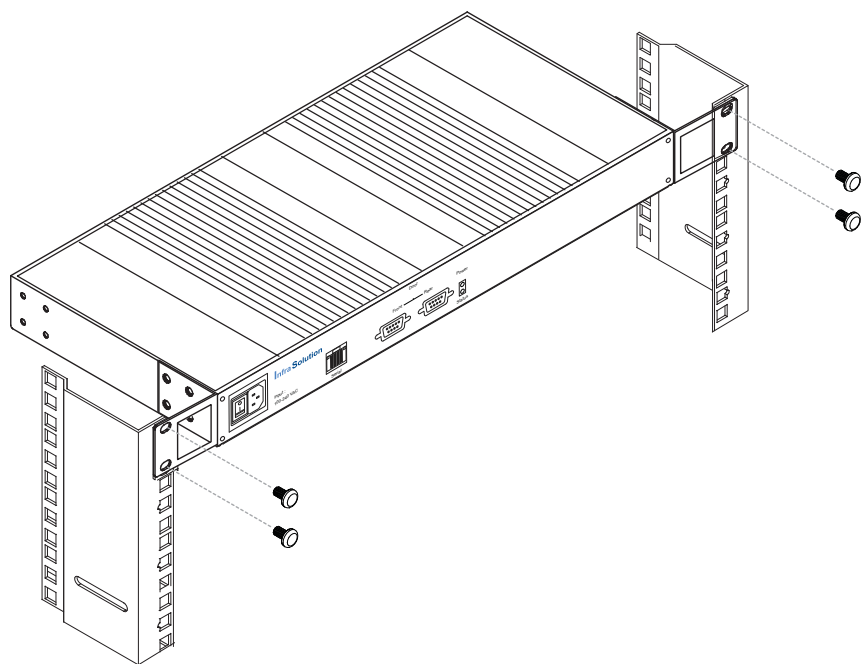

Content

Part I. InfraBox Installation

< 1.1 > Package Contents	P.1
< 1.2 > Overall Installation Diagram for Cabinet	P.2
< 1.3 > Connection Diagram for Temp. sensor & PDU	P.4
< 1.4 > Temp. & Humidity Sensor Connection & Specifications	P.5
< 1.5 > Cascade Connection	P.6

Part II. Handle Installation

< 2.1 > Handle Mounting Cut-out & Installation	P.7
< 2.2 > Two Important Notes about Handle	P.12
< 2.3 > Handle Operation	P.14

Part III. Door Sensor Installation

< 3.1 > Inductive Sensor	P.16
< 3.2 > Mechanical Sensor	P.18

Part IV. Network Setup

< 4.1 > Daisy Chain	P.20
< 4.2 > Star	P.20
< 4.3 > Mixed	P.21

Part V. Application

< 5.1 > Data Center	P.22
< 5.2 > Intelligent Building	P.23
< 5.3 > Remote Site	P.24
< 5.4 > Branches	P.25

Part VI. Hardware Specifications	P.26
--	------

Content

Part VII. IP Setup Utilities for InfraBox	P.27
--	------

Part VIII. Software Installation & Activation

< 8.1 > Hardware Requirement	P.28
< 8.2 > Software Installation	P.29
< 8.3 > Software Activation	P.34

Part IX. Setup & Operation

< 9.1 > Legend Definition	P.36
< 9.2 > Cabinet Setup & Configuration	P.36
< 9.3 > User Setup & Configuration	P.41
< 9.4 > Card Assignment	P.44
< 9.5 > Monitoring & Control of Cabinet	P.45
< 9.6 > Log Record & Report	P.45

Part X. General System Setup

< 10.1 > Floor Plan Background / Warning / Temperature Unit	P.46
< 10.2 > Database Management	P.47
< 10.3 > Services Setup (Software SNMP / Email)	P.48
< 10.4 > Time Zone / Time Rule	P.49

Part XI. Backup & Restore	P.51
--	------

Part XII. FAQ	P.53
----------------------------	------

Part XIII. Troubleshooting	P.54
---	------

Part XIV. Optional Accessories	P.55
---	------

Part I. InfraBox Installation

< 1.1 > Package Contents

Unpacking

The equipment comes with the standard parts shown on the package contents. Check and make sure they are included and in good condition. If anything is missing, or damage, contact the supplier immediately.

Package Content

- 820 LAN Box x 1 **OR** 840 LAN Box x 1
- Smart card handle, pair (MiFARE **OR** Proximity)
- Inductive **OR** Mechanical Door Sensor, pair
- Front door cable x 1 (3425mm)
- Rear door cable x 1 (2625mm)
- 6' Power cord x 1
- Activated SmartCard x 1
- Key x 1
- Cable clip x 8



Handle mounting screw set :

- Handle mounting bracket x 2
- M3 x 7mm screw x 8
- M4 x 9mm screw x 4
- M5 x 10mm screw x 2
- Circle hole washer x 2
- Square hole washer x 6

Patented and Worldwide
Patents Pending

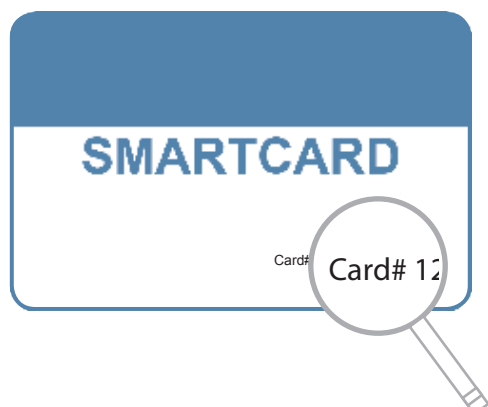
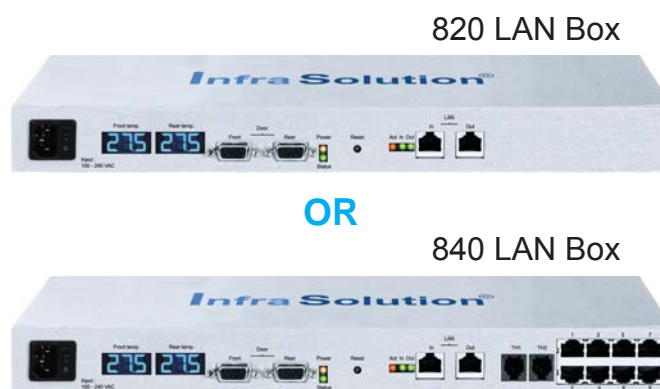

Each package bundled with smartcard x 1. The card on the bottom right shows card number information :

< 1.2 > Overall Installation Diagram for Cabinet

Infra-820

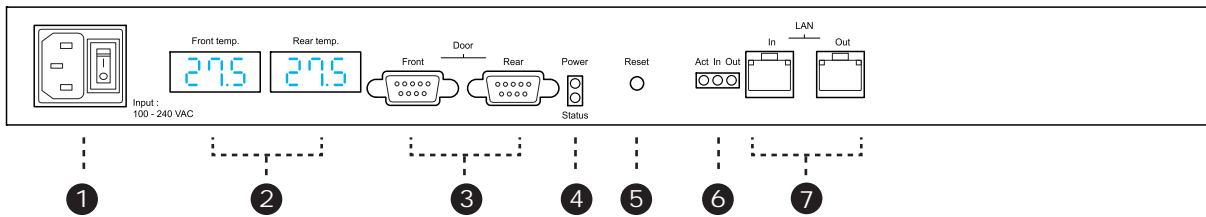

Infra-840

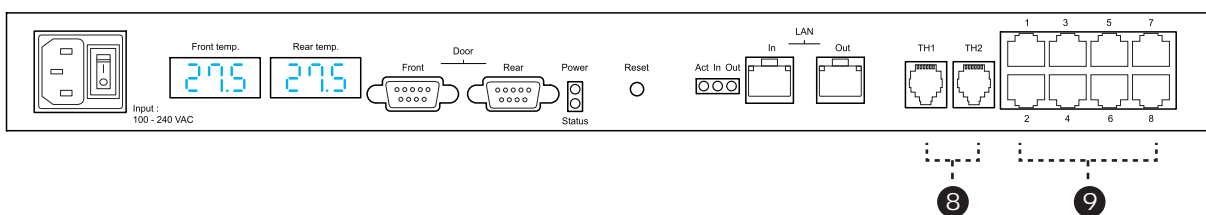

- ① **Power Input**
- ② **Temp. LED x 2**
Indicate the front and rear door temperature from the built-in handle temperature sensor
- ③ **Door cable DB-9 connector x 2**
Connect to the front and rear handle via 2 pcs of all-in-one door cable
- ④ **Power & status LED**
- ⑤ **Power Reset button**
- ⑥ **“Act in Out” LED**
- ⑦ **Daisy chain RJ45 LAN port x 2**
- ⑧ **Temp. / Temp. + Humid. RJ11 sensor port x 2**
Connect sensor cable
- ⑨ **PDU RJ45 connection port x 8**
Up to PDU connection x 8

Part I. InfraBox Installation

< 1.2 > Overall Installation Diagram for cabinet

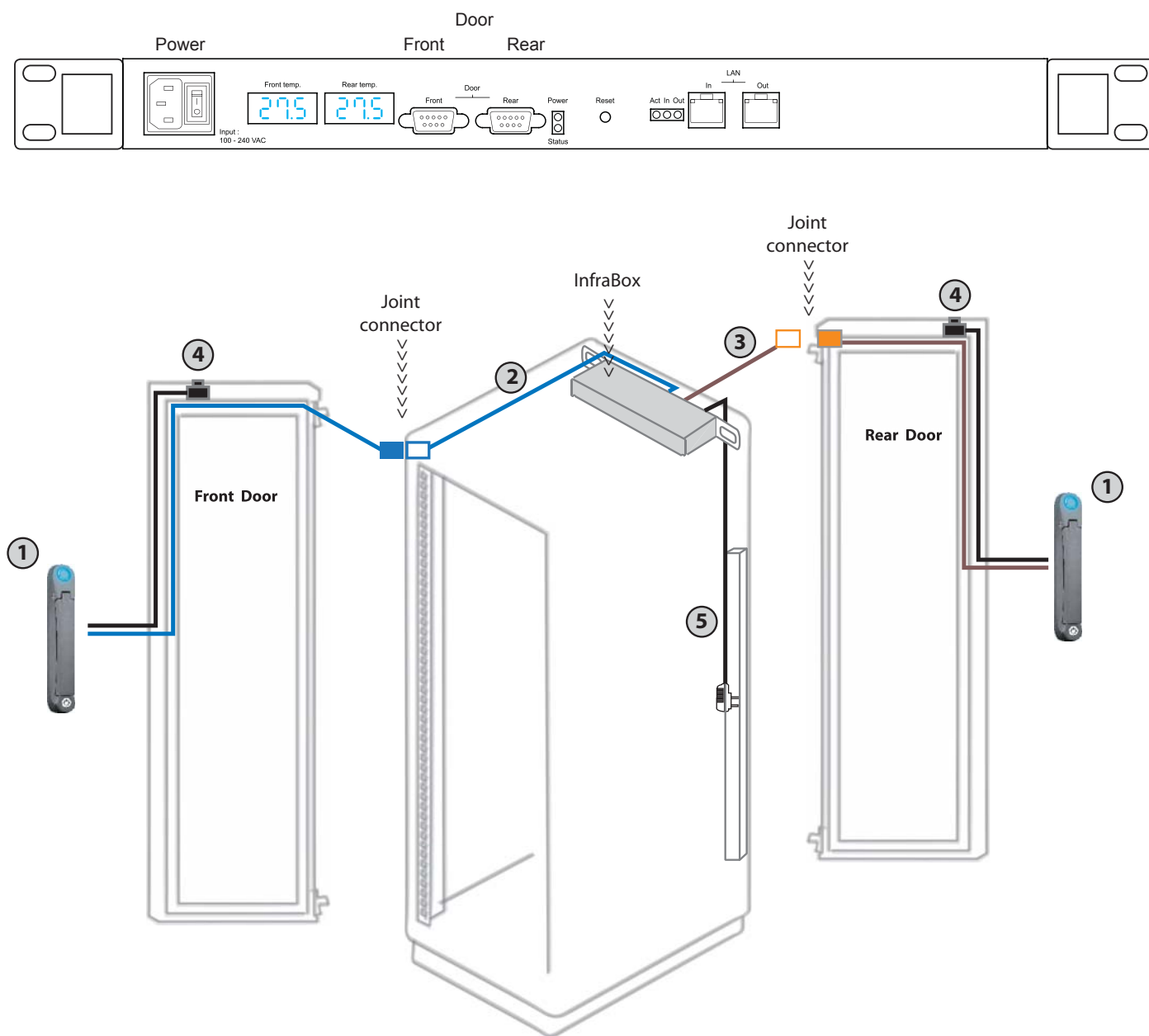

- ① HV-800 SmartCard handle x 2
- ② Front door cable (3425mm) with joint connector x 1
- ③ Rear door cable (2625mm) with joint connector x 1
- ④ Door sensor (connect to the smartcard handle) x 2
- ⑤ 6' power cord x 1

< 1.3 > Connection Diagram for Temp. sensor & PDU

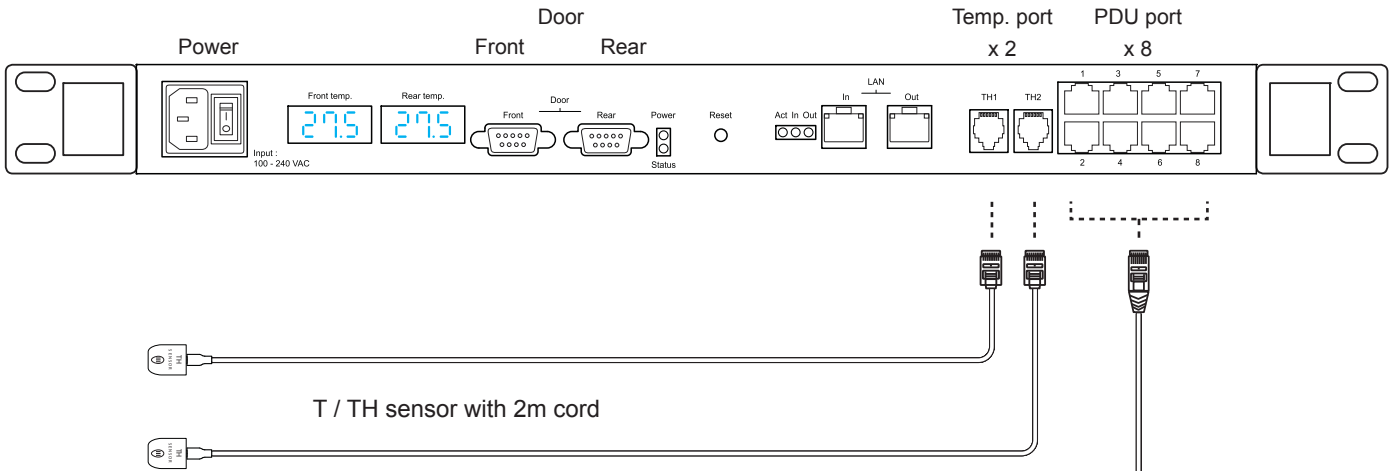

- Up to PDU connection x 8
- Each PDU connection via Cat5/6 cable up to 20m
- Connect to the **LINK** port of PDU meter
- MT & MTS compatible

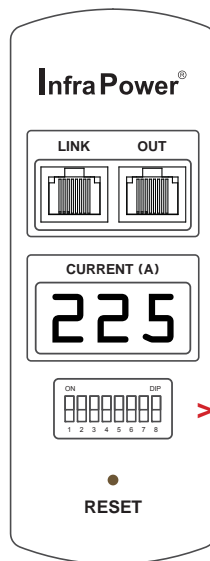
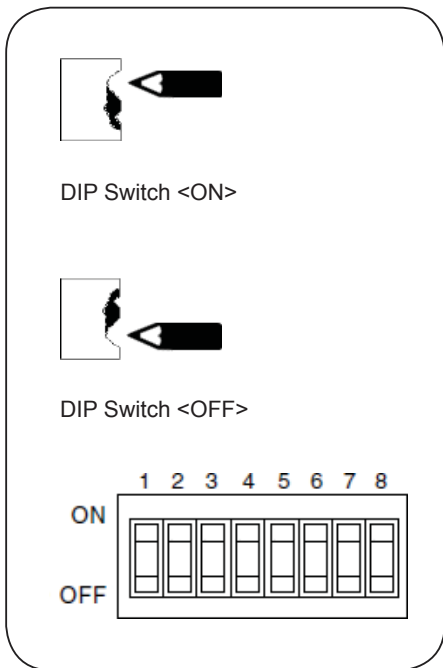

Dip switch setting :

PDU Dip switch no.				
1	2	3	4	8
On	On	On	On	Off



Part I. InfraBox Installation

< 1.4 > Temp. & Humidity Sensor Connection & Specifications

		Temp. & Humid. Sensor
Part no.		IG - TH01
Temperature Sensitivity	Range	0 to 80°C (32 to 176°F)
	Accuracy	±1.0°C typical (±2°F)
	Resolution	0.1°C (0.2°F)
	Response Time	5 to 30 sec
Relative Humidity Sensitivity	Range	0 to 100% R.H
	Accuracy	0 to 100, ±8.0% R.H 20 to 80, ±4.5% R.H.
	Resolution	1% R.H.
	Response Time	8 sec
Power Requirement	Voltage	12VDC, powered by sensor port
	Current Consumption	20mA
	Power consumption	0.24 Watt
	Power on indicator	Red LED
Housing	Chassis & Cover	plastic
	Color	Dark gray
	Installation	Magnetic base for unrestricted installation
Cable	Cable Length	TH sensor w/ 2m cable (standard) TH sensor w/ 4m cable (option)
	Cable Specification	4-wired 3.5mm to RJ11
	Cable Color	Black
Environmental	Operating	0 to 80°C Degree
	Storage	-5 to 80°C Degree
	Humidity	0~100%, non-condensing
Dimensions	Product	30L x 25Wx 18H mm
Weight	Net	10g
Compatibility	InfraPower	W / WS / Wi / WSi series PDU
	InfraSolution	X-2000 series
	InfraGuard	Cabinet sensor system

< 1.5 > Cascade Connection

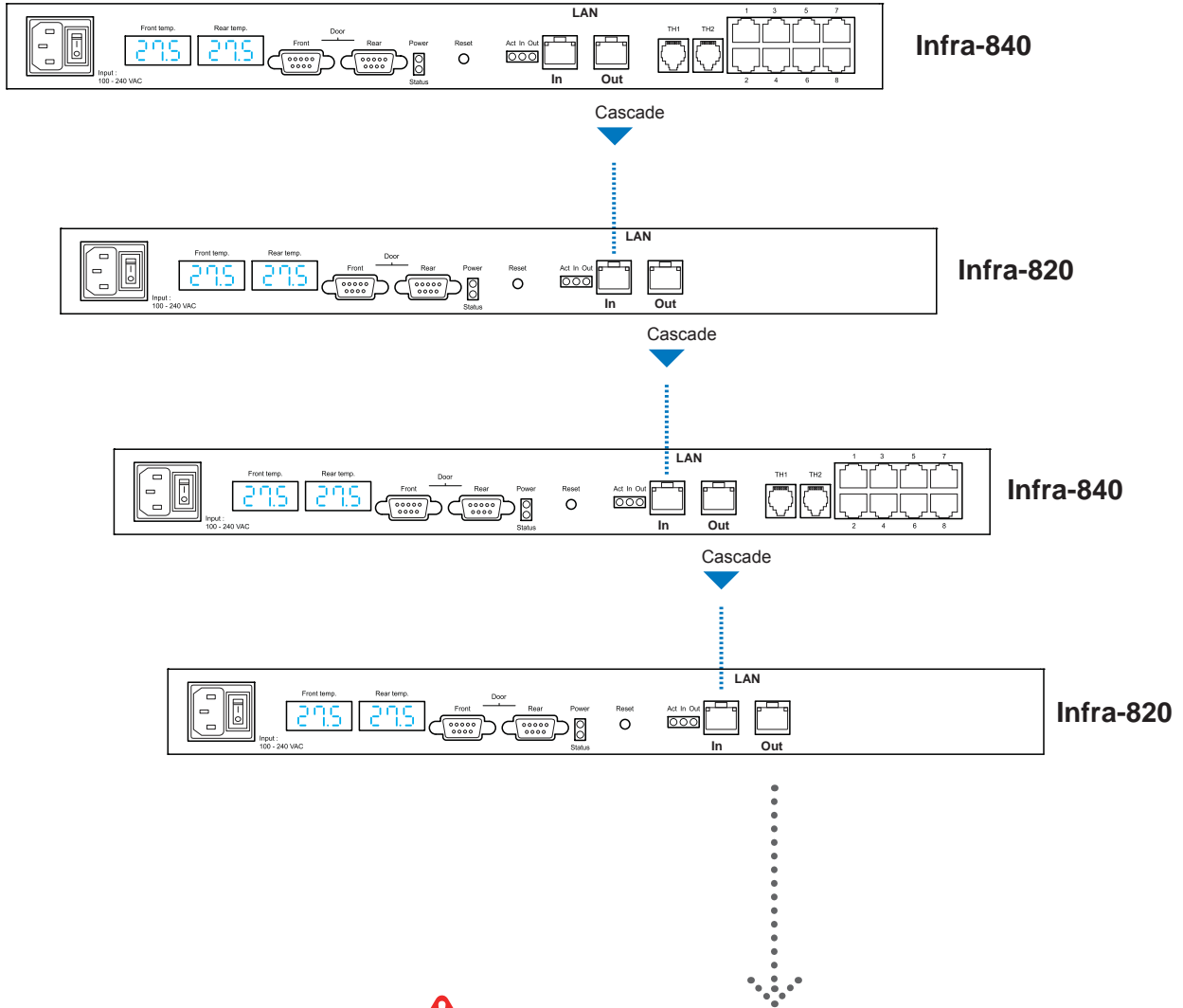

- The total length of a single daisy chain is 100m max.
- The total Infrabox of a single daisy chain is 50 boxes max.

Part II. Handle Installation

< 2.1 > Handle Mounting Cut-out & Installation

Installation

To achieve the highest level of interoperability offered in the cabinet industry, the HV-800 handle applies the universal mounting cut-out. It avoids costly and complicated door customization for the smartcard handle integration.

Universal Mounting Cut-out :

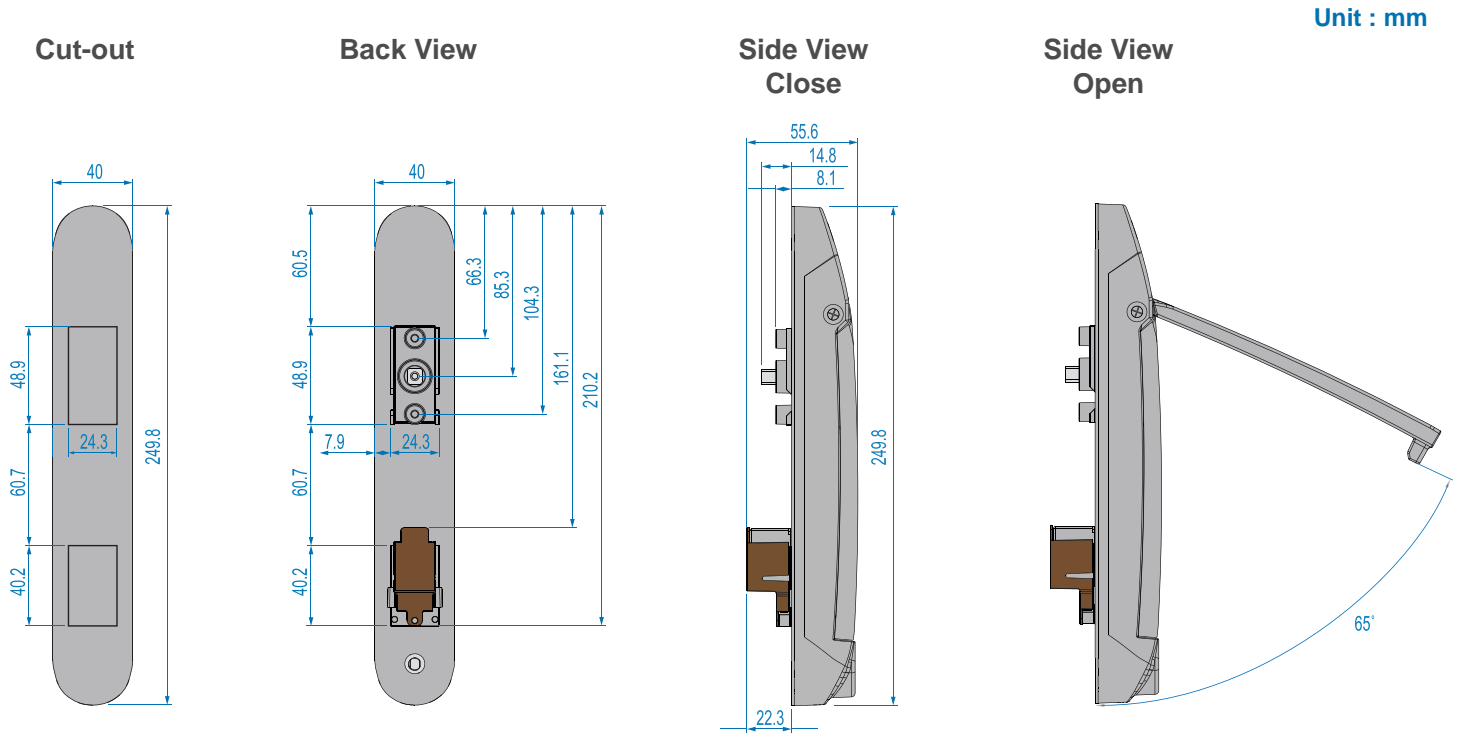

Handle Models of left / right side opening

HV-800P / HV-800M support left side open. If user requires right side open, please order HV-800P-R / HV-800M-R.

Model	Left side	Right side open
HV-800P	✓ Proximity	
HV-800M	✓ MiFARE	
HV-800P - R		✓ Proximity
HV-800M - R		✓ MiFARE

< 2.1 > Handle Mounting Cut-out & Installation

Installation for **Single Point Lock**

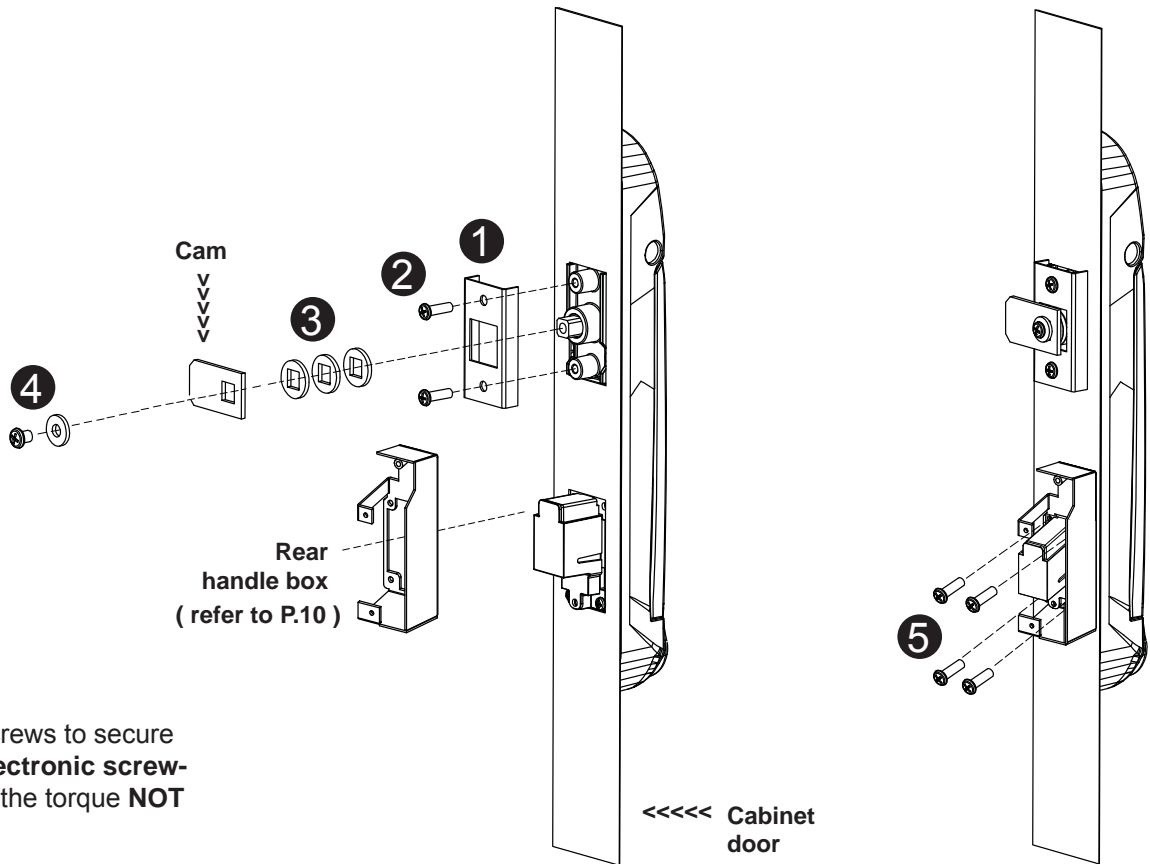

While insert the screws to secure the handle with **electronic screw-driver**, please set the torque **NOT** exceed 8 kgf/cm

1. Mount the smartcard handle to the universal mounting position.
2. Place the ① handle mounting bracket with ② M4 x 9mm screw x 2 to secure the handle.
3. Attach the **Cam** with ③ square hole washer(s) to adjust and to fit the cam locking position.
Note : - If the cam cannot fit the locking position after adjustment, customization for the cam is required.
- Cam customization service upon your request, please contact your sales representative
4. Insert the ④ M5 x 10mm screw x 1 with circle hole washer to secure the **Cam** to the handle.
5. Insert ⑤ M3 x 7mm screw x 4 to further secure the handle & rear handle box in place.

Handle mounting screw set for single point lock

		Qty.	Single Point Lock
①	Handle mounting bracket	2	✓
②	M4 x 9mm screw for ①	4	✓
③	Square hole washer	6	✓
④	Circle hole washer w/ M5 x 10mm screw	2	✓
⑤	M3 x 7mm screw	8	✓

Part II. Handle Installation

< 2.1 > Handle Mounting Cut-out & Installation

Installation for **2-point Lock** (light-duty rod-latch)

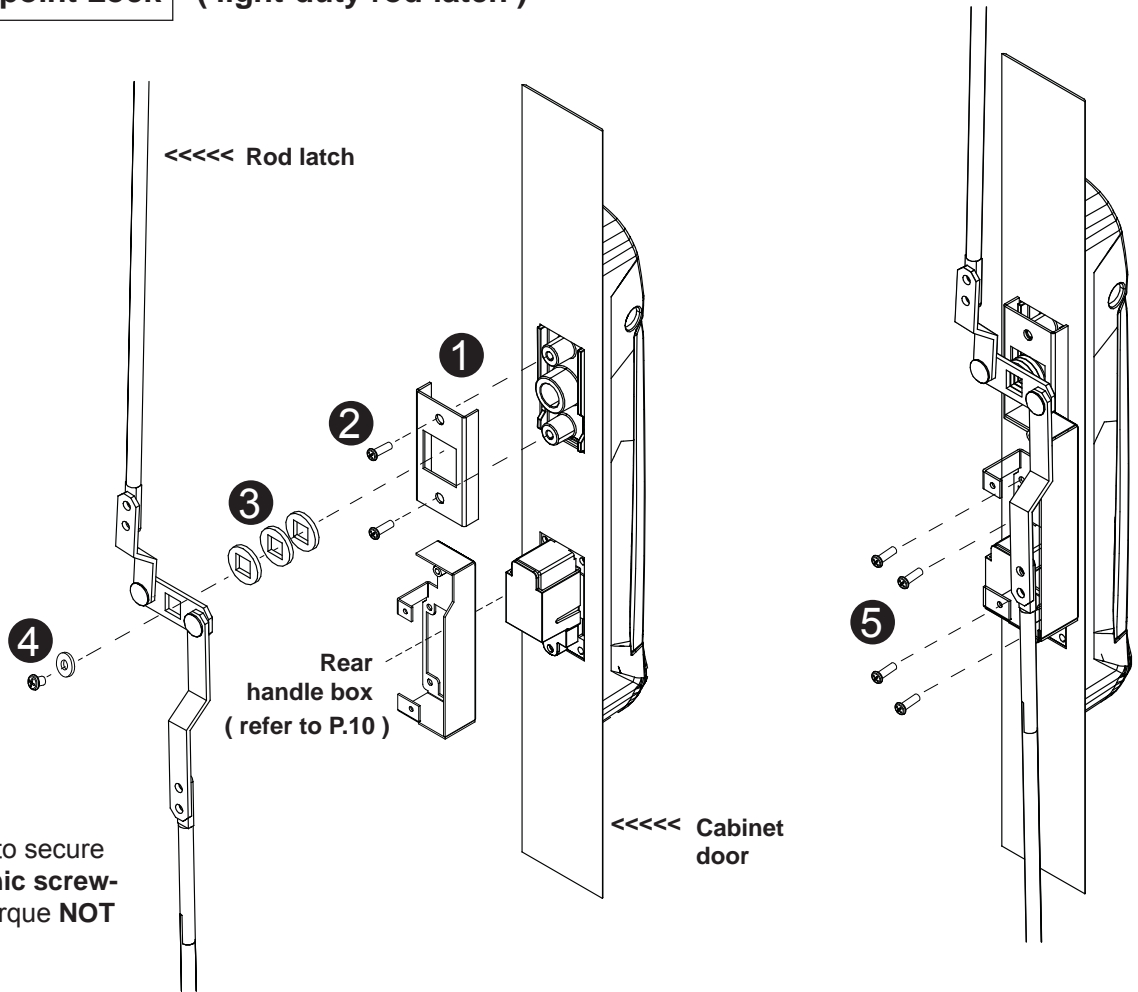

While insert the screws to secure the handle with **electronic screw-driver**, please set the torque **NOT** exceed 8 kgf/cm

1. Mount the smartcard handle to the universal mounting position.
2. Place the ❶ handle mounting bracket with ❷ M4 x 9mm screw x 2 to secure the handle.
3. Attach the **Rod-latch** with ❸ square hole washer(s) to adjust and to fit the door top & bottom locking position.
4. Insert the ❹ M5 x 10mm screw x 1 with circle hole washer to secure the **Rod-latch** to the handle.
5. Insert ❺ M3 x 7mm screw x 4 to further secure the handle & rear handle box in place.

Handle mounting screw set for 2-point lock (light-duty)

		Qty.	2-Point Lock (light-duty)
❶	Handle mounting bracket	2	✓
❷	M4 x 9mm screw for ❶	4	✓
❸	Square hole washer	6	✓
❹	Circle hole washer w/ M5 x 10mm screw	2	✓
❺	M3 x 7mm screw	8	✓

< 2.1 > Handle Mounting Cut-out & Installation

Installation for **2-point lock** (rod control system)

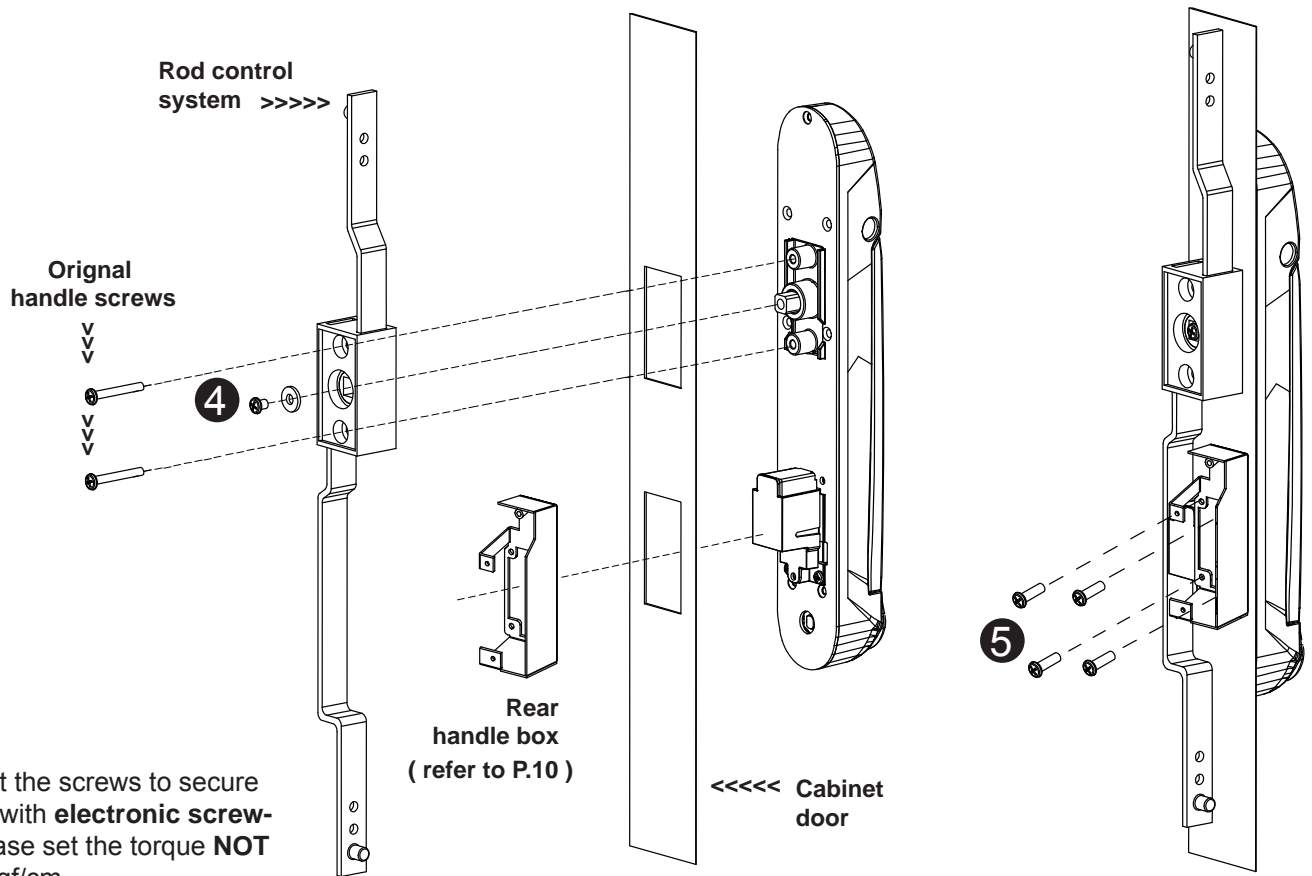

While insert the screws to secure the handle with **electronic screw-driver**, please set the torque **NOT** exceed 8 kgf/cm

1. Mount the smartcard handle to the universal mounting position.
2. Attach the **Rod control system** to the handle and insert the **④** M5 x 10mm screw x 1 with circle hole washer to secure the position.
3. Insert **Original handle screws** x 2 through the **Rod control system** and door to the handle to fix it in place.
4. Insert **⑤** M3 x 7mm screw x 4 to further secure the handle & rear handle box in place.

Handle mounting screw set for 2-Point Lock (with rod control)

		Qty.	2-Point Lock (with rod control)
①	Handle mounting bracket	2	
②	M4 x 9mm screw for ①	4	
③	Square hole washer	6	
④	Circle hole washer w/ M5 x 10mm screw	2	✓
⑤	M3 x 7mm screw	8	✓

Part II. Handle Installation

< 2.1 > Handle Mounting Cut-out & Installation

Connection for rear handle box

After secured the handle, the user should connect cables x 4 to the rear handle box.

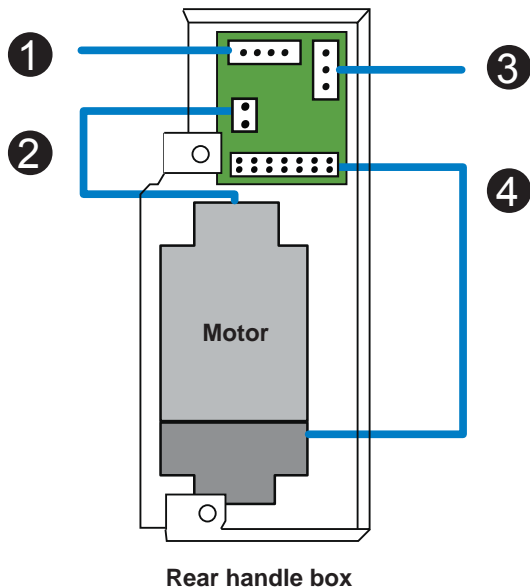

①	4-pin connector to front or rear door cable
②	2-pin connector to motor cable
③	3-pin connector to door sensor cable
④	14-pin connector to handle cable

Complete the installation

Secure the rear handle box cover.

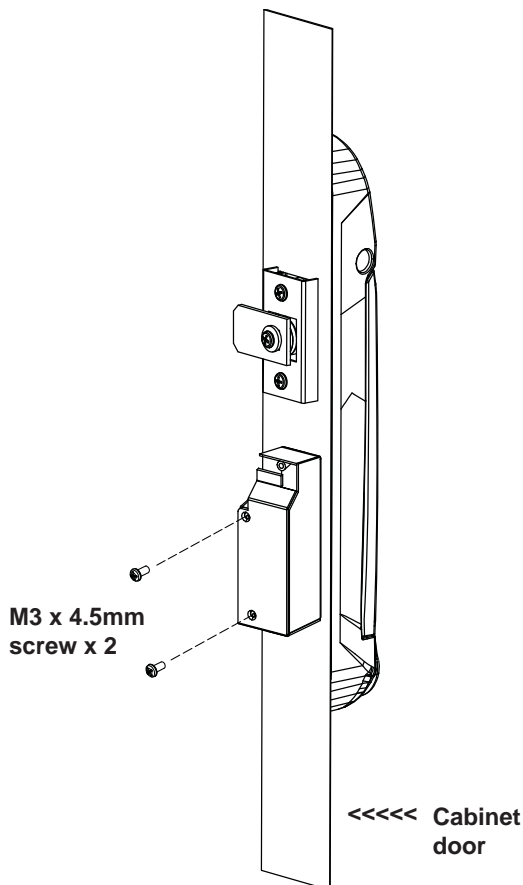

< 2.2 > Two Important Notes about Handle

Handle Sensor Area & SmartCard Mode

Sensor area



Present the smartcard and touch the handle sensor area for 1 to 2 seconds

Smartcard mode



For smartcard operation, keep key cylinder always to **12 o'clock direction**.

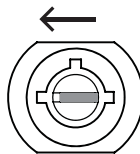

Key lock mode

Key cylinder to **9 o'clock direction**
Under key lock mode, even present the smartcard, the handle still keeps locked.

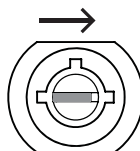

Key unlock mode

Key cylinder to **3 o'clock direction**
Under key unlock mode, the handle keeps unlocked.

Part II. Handle Installation

< 2.2 > Two Important Notes about Handle

Lock / Unlock the handle by mechanical key



- Unless the smartcard handle is defective, lock / unlock the handle by key is NOT recommended
- Please insert & turn the key with push force

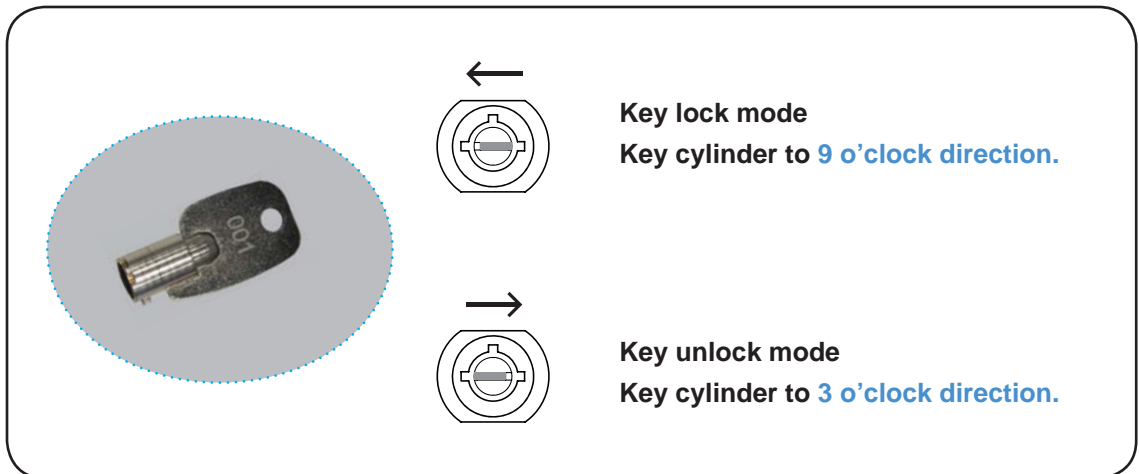

Maintenance Key (MK-001)

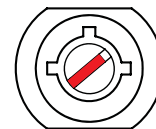

- Improper key usage may cause the cylinder stuck at abnormal direction 1 to 2 o'clock.
- Under this circumstance, the **maintenance key (MK-001)** is required to solve the problem.
- Please insert the **maintenance key** to the cylinder with push force for turning it to normal direction 9 or 12 or 3 o'clock.



< 2.3 > Handle Operation

✓ How to unlock the handle & open the door properly

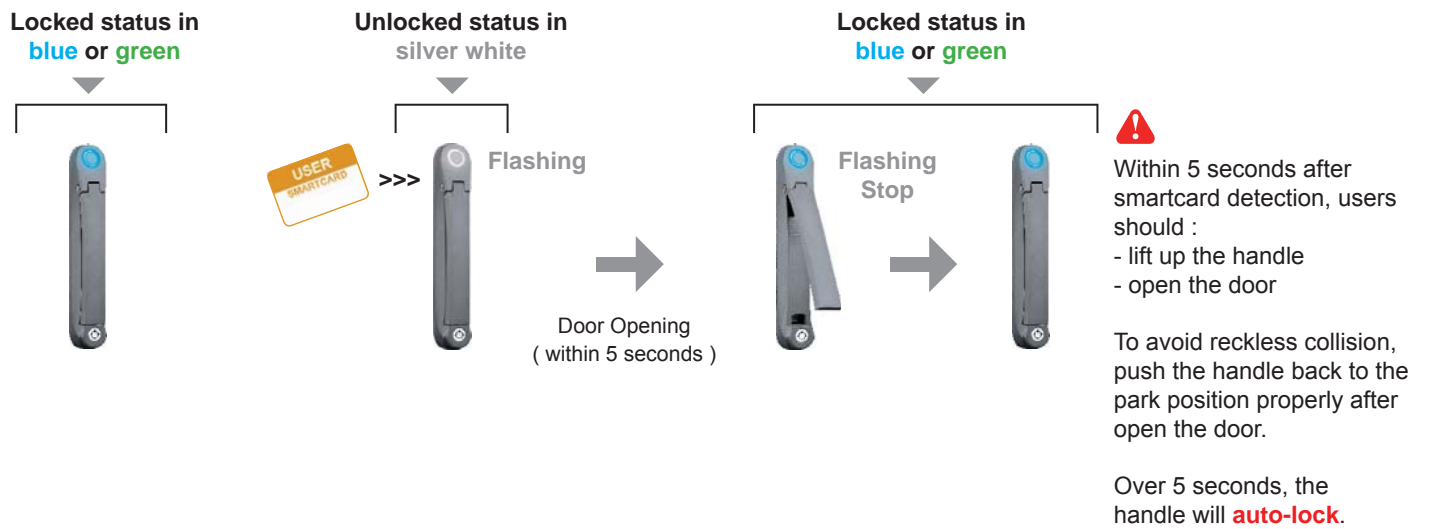

✓ How to close the door properly

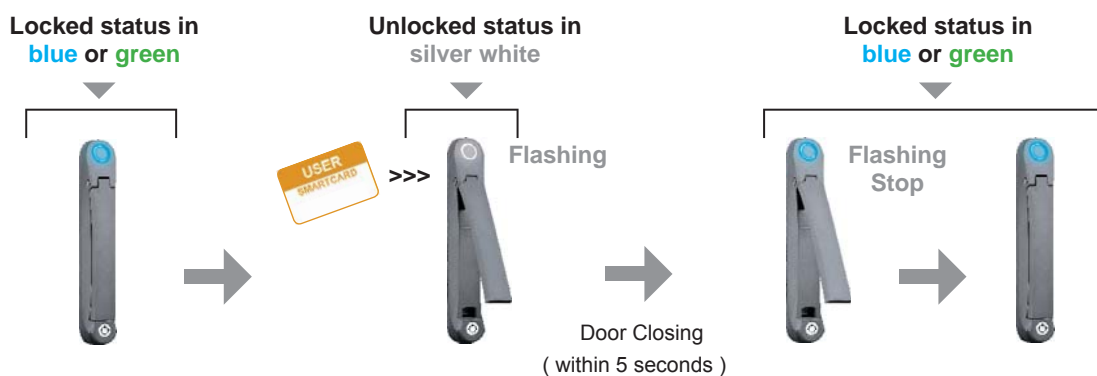

- Warning: After smartcard detection, users should :
- 1) lift up the handle
 - 2) close the door
 - 3) over 5 seconds, the handle will **auto-lock**, then return the handle to park position properly

IMPORTANT NOTE :

User **MUST** follow the step no.3, otherwise, the handle locking will fail.

Part II. Handle Installation

< 2.3 > Handle Operation

Unauthorized door-open

Locked status in
blue or green



NO Authenticated
Smartcard Detection



Door Opening
improperly or by force

Unlocked status in
red



Flashing



If the door is opened improp-
erly or by force, handle LED
will turn to **red flashing** with
audio alarm 'beep' sound.

Part III. Door Sensor Installation

< 3.1 > Inductive Sensor

Optional door sensor is an essential accessories as users can be alerted by visual and audio alarm for unauthorized access.

Inductive Door Sensor, pair (ISO-DSI)



Features

- light weight / adhesive
- mini size (32.5 x 12.2 x 9.2 mm)
- no custom cutting required on door

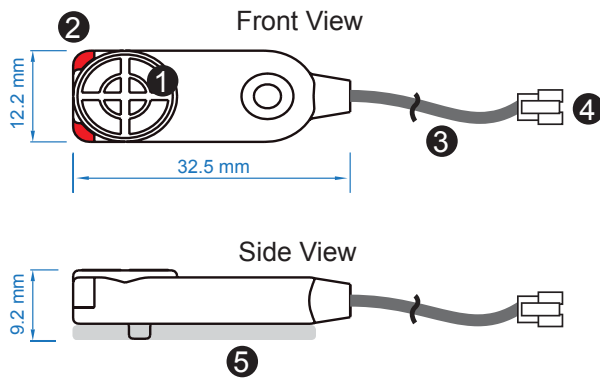

①	Sensor area
②	Red LED (light up while door opening)
③	2m cable
④	Cable jack (connect to handle)
⑤	2mm adhesive tape

Package content

- Inductive sensor w/ 2m cable x 2
- 2mm adhesive tape x 6



Requirements

- cabinet frame made of ferrous metal (iron)
- sensing distance 3mm

Part III. Door Sensor Installation

< 3.1 > Inductive Sensor

Installation steps

- connect to the handle
- guide & fix the cable with cable clips (bundle with handle package)
- place the sensor at the top of the door, close to the opening side
- adjust the sensor with adhesive tape to ensure the sensing distance between door to frame within 3mm while door in close status



Sensor Operation

DOOR CLOSE

- close door
- inductive sensor detects the cabinet frame
- DOOR CLOSE SIGNAL sends out

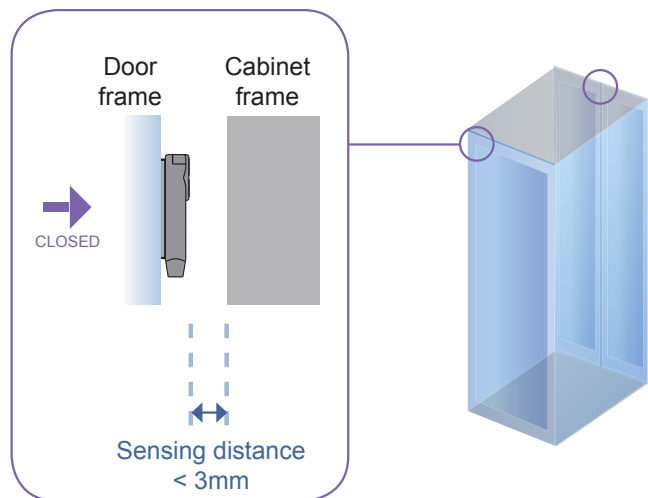

DOOR OPEN

- open door
- inductive sensor lose detection with cabinet frame
- Red LED of sensor light up
- DOOR OPEN SIGNAL sends out

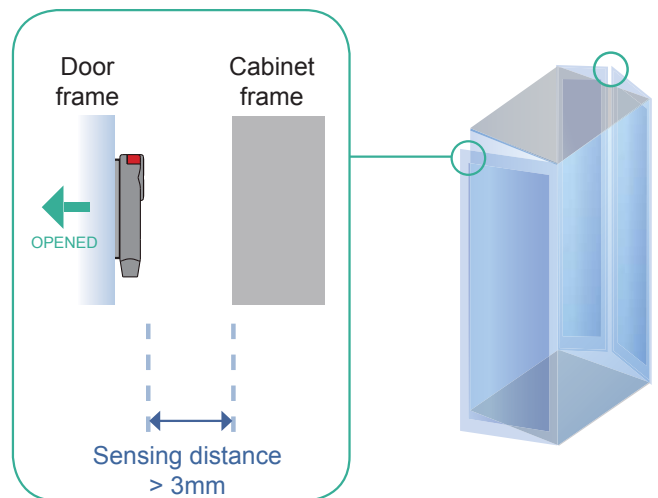

< 3.2 > Mechanical Sensor

Mechanical Door Sensor (ISO-DSW)

Features

- low cost / precise
- cost efficient integration to new cabinet

unit : mm

Front View

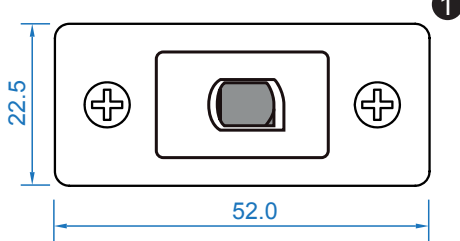

Top View

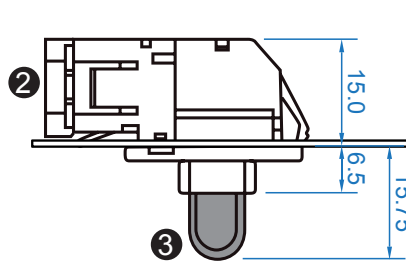

Side View

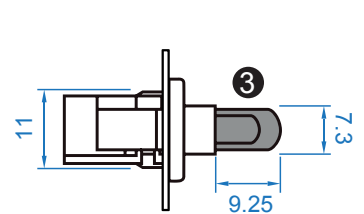

①	Steel mounting plate with 2 screw holes
②	Cable connector
③	Press button (total travel distance : 9.25 mm) (min. actuation distance : 3.00 mm)

Package content

- Mechanical sensor w/ 2m cable x 2
- Mounting screws 6#32x4.5mm x 2



Requirements

- custom hole cutting required on doors
- ordering a sample for custom cutting is highly suggested
- min. actuation distance : 3.00 mm
- total travel distance : 9.25 mm

unit : mm

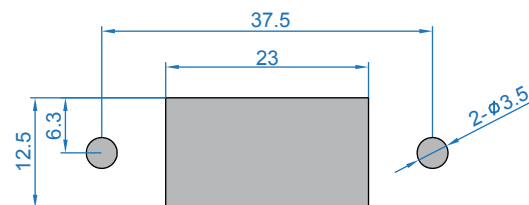

Dimension of door cutting hole

- circle hole x 2 for screw mounting
- rectangle hole x 1 for sensor installation

Part III. Door Sensor Installation

< 3.2 > Mechanical Sensor

Installation steps

- connect to the handle
- place the sensor at the top middle of the door
- install the sensor in the custom hole
- secure it with bundled mounting screws 6#32x4.5mm x 2

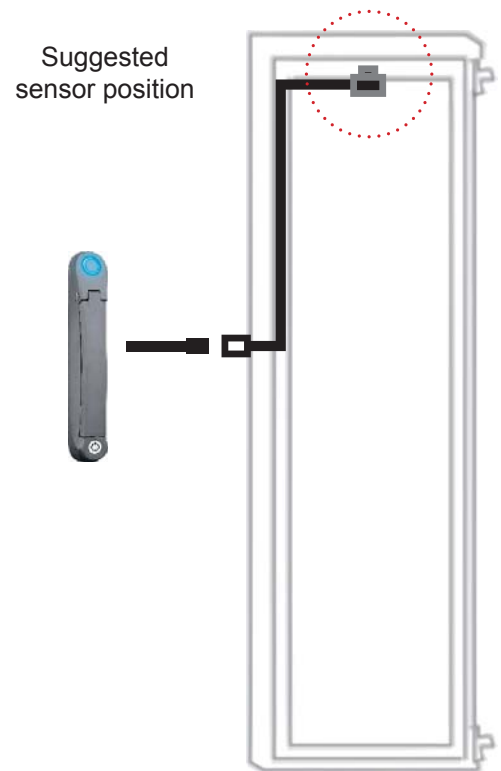

Sensor Operation

DOOR CLOSE

- close door
- Sensor button is pressed on
- DOOR CLOSE SIGNAL sends out

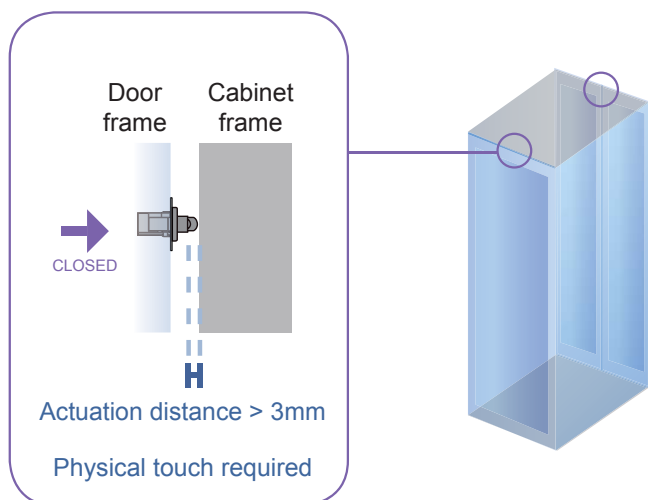

DOOR OPEN

- open door
- Sensor button is released
- DOOR OPEN SIGNAL sends out

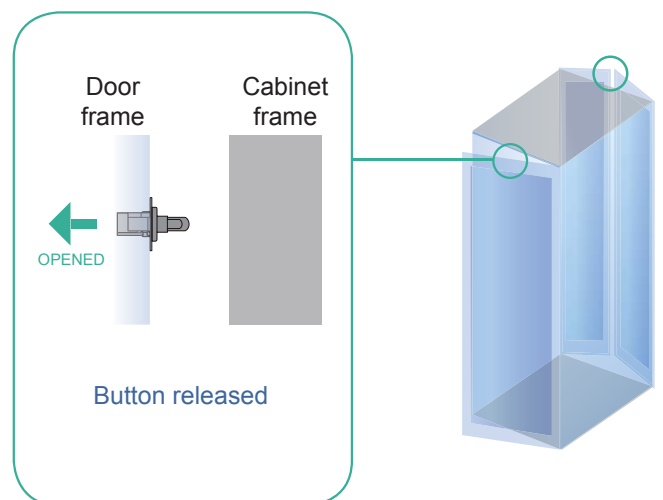

Part IV. Network Setup

InfraSolution provides 3 connection ways - **Daisy Chain**, **Star**, **Mixed**.

Which connection users apply is related to the site scale, environment and users' requirements.

< 4.1 > Daisy Chain Connect all InfraBoxes by Cat5/6 cable, and no any network switch required

Key Benefits

- Simple connection
- No network switch required
- Appropriate for small networks

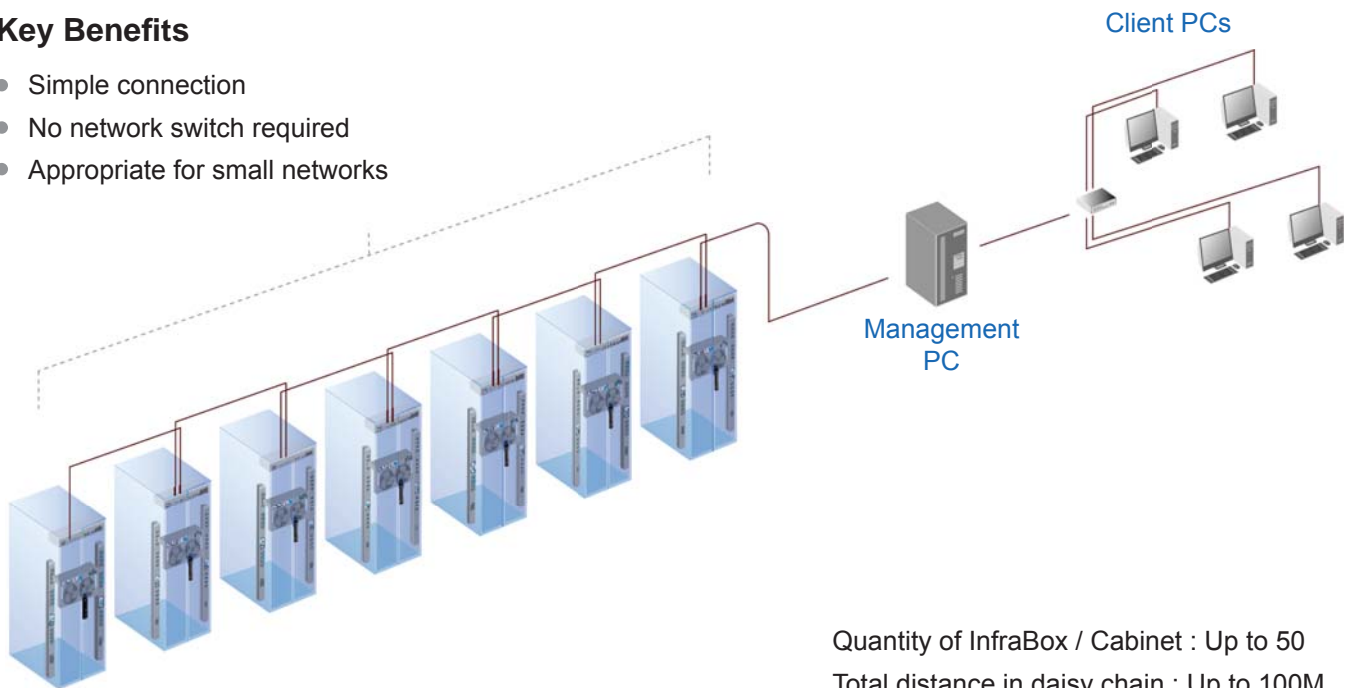

< 4.2 > Star Connect to network switch by a point-to-point connection

Key Benefits

- Appropriate for large networks
- Increased fault tolerance
- Easy for troubleshooting

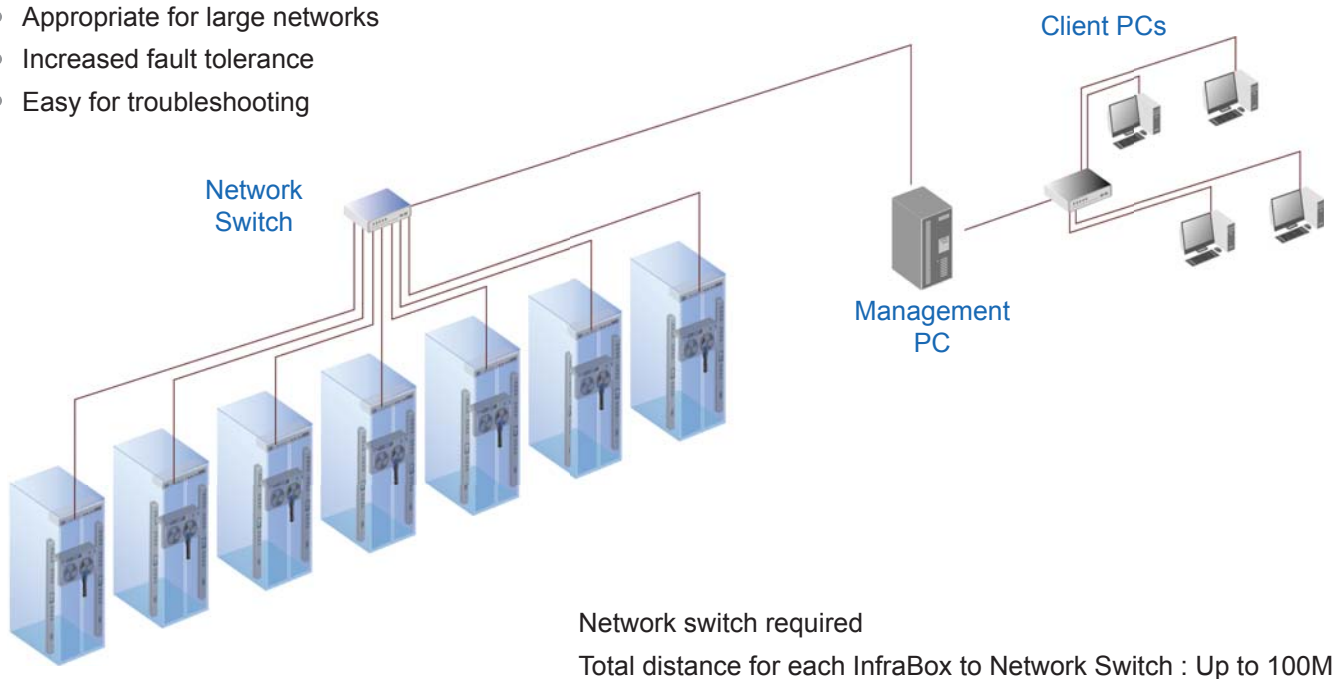

Part IV. Network Setup

< 4.3 > Mixed Combining daisy chain with star connection

Key Benefits

- Most effective and practical for large scale of networks
- Take all advantages of Daisy Chain and Star connection
- Flexible to meet a variety of network environments and needs

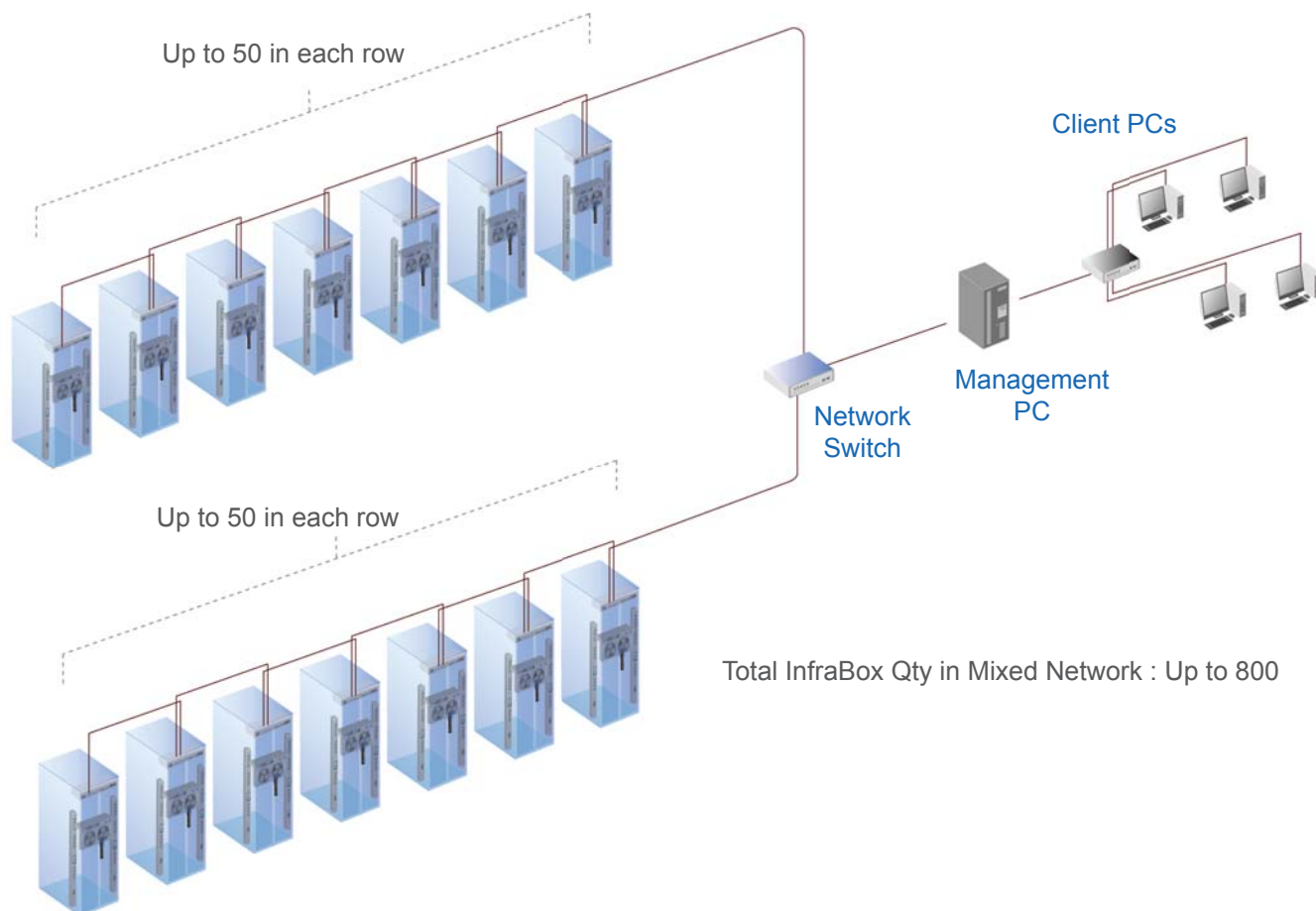

Part V. Application

< 5.1 > Data Center

By mixed connection, InfraSolution can be scalable up to 800 cabinets and the 2200 and 2400 InfraBoxes can be coexisted in the same network. Users are enabled to manage and remotely access all cabinets under a centralized and user friendly GUI.

- Connect the 1st InfraBox in each daisy chain to the network switch
- Connect the management PC and client PCs via the network switch
- Up to 800 Infraboxes / Cabinets

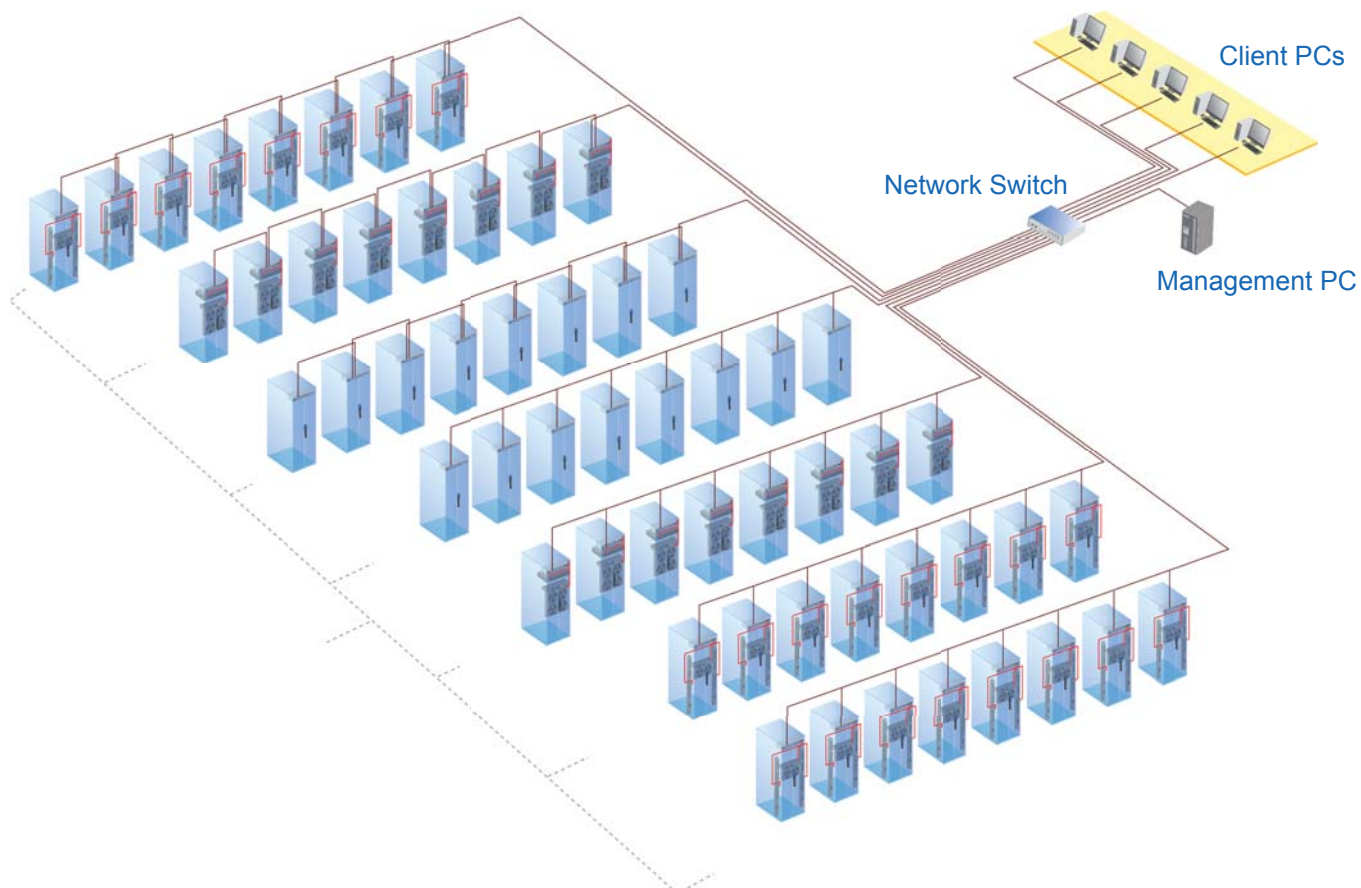

Part V. Application

< 5.2 > Intelligent Building

It is essential for a Multi-Storey Intelligent Building to be applied with a centralized management system for the building's mechanical and electrical equipment such as security, power, ventilation, and lighting systems, etc.

InfraSolution system allows equipment to be distributed throughout a building simply by deploying an Ethernet network. To keep capital costs down, InfraSolution can also be cascaded between boxes up to 100m over a Cat5/6 cable. Signal weakness problem for long distance between InfraBoxes can be solved by applying network hubs with repeater function.

Setup Scenario in the whole Intelligent Building

- Connect the InfraSolution network in each floor via the network ethernet / fiber switch
- Up to 800 Infraboxes / Cabinets

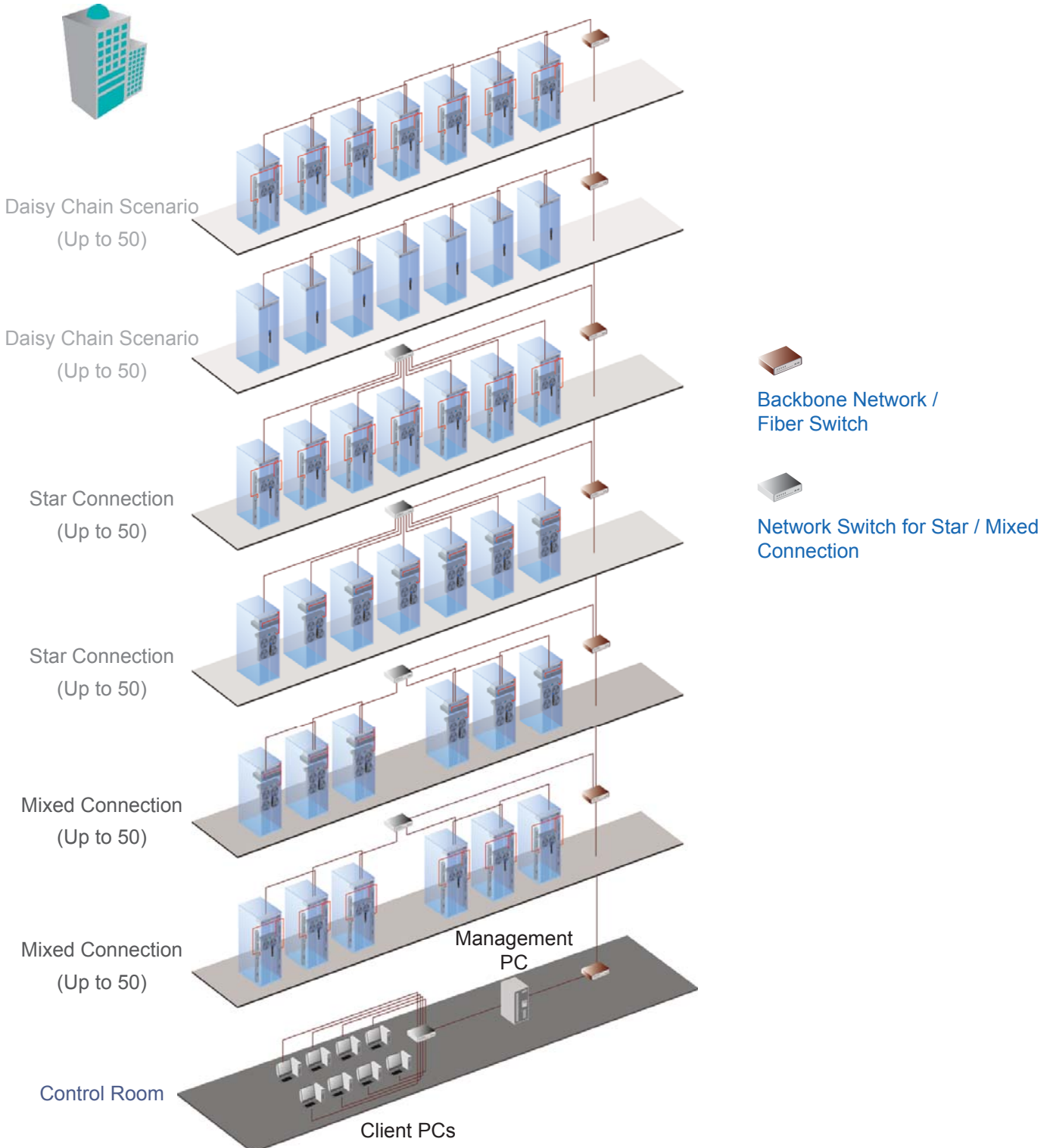

< 5.3 > Remote Site

Besides data centers and intelligent buildings, InfraSolution can be also applied to the remote site for access and monitoring over IP anytime and anywhere.

Optional IP Remote Box IS-101 with SSL security is available for the remote management over IP.

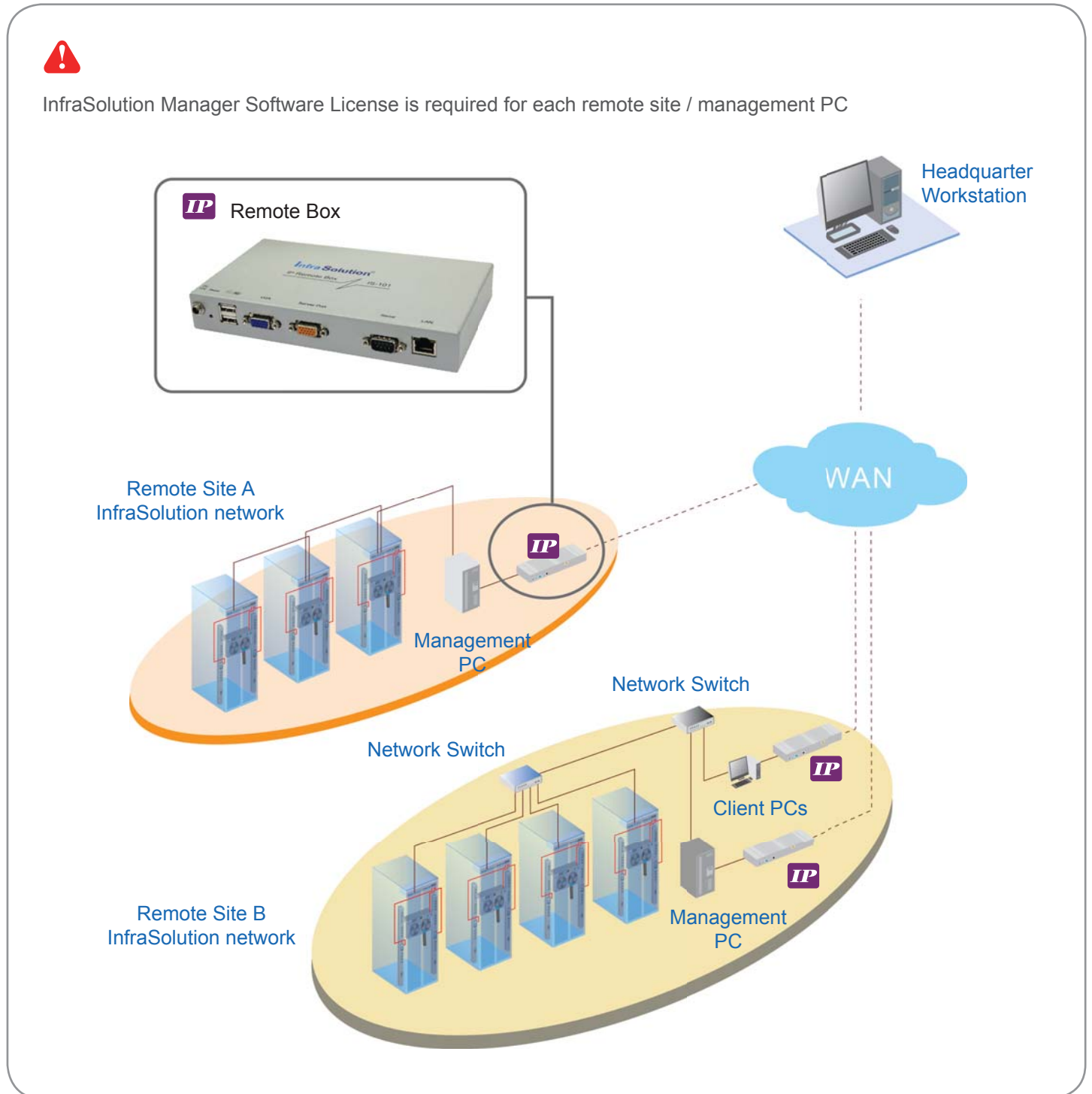

Part V. Application

< 5.4 > Branches

How to manage a number of branches by InfraSolution

For a global or scalable company, it is vital to remote access and monitor the network of their nationwide and worldwide branches. InfraSolution provides an ideal solution to keep an eye on cabinet access security and environmental condition.



InfraSolution Manager Software License is required for each remote site / management PC

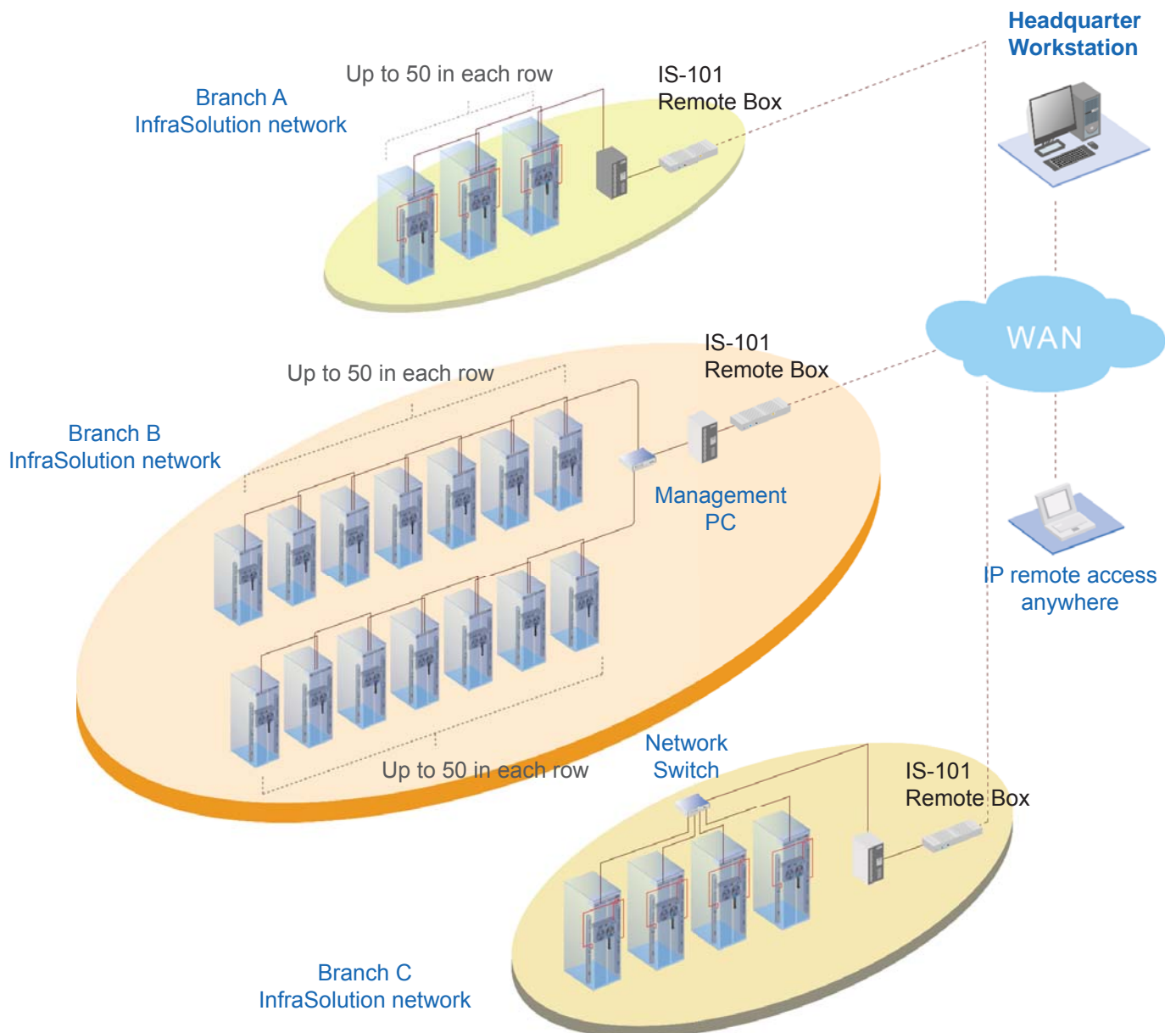

Part VI. Hardware Specifications

Item	Power	100~240VAC, 50 / 60Hz 0.5A via AC / DC cord
	Regulation Approval	FCC, CE
	Casing Material	Steel & aluminum, silver colour

Environmental	Operation	0° to 50°C Degree
	Storage	-5° to 60 °C Degree
	Relative Humidity	90%, non-condensing
	Shock	50G peak acceleration (11 ms, half-sine wave)
	Vibration	58~100Hz / 0.98G (11ms / cycle)

Dimension	Product (W x D x H)	410 x 135 x 39.7 mm 16.1 x 5.3 x 1.56 inch
	Packing (W x D x H)	557 x 367 x 98 mm 21.9 x 14.4 x 3.9 inch

Weight	Net	1.16 kg / 2.55 lbs
	Gross	2.3 kg / 5.06 lbs

Part VII. IP Setup Utilities for InfraBox

After the completion of InfraBox connection, please take the following steps to configure the InfraBox :

1. Prepare a notebook computer to download the **IP setup utilities for InfraBox** from the following link:
<http://www.austin-hughes.com/support/utilities/infrasolution/InfraBoxSetup.msi>
2. Double click the **IP setup utilities for InfraBox.msi** and follow the instruction to complete the installation.
3. Go to each InfraBox with the notebook computer & a piece of CAT. 5 / 6 cable to configure InfraBox as below. Please take the procedure for all InfraBoxes ONE BY ONE.

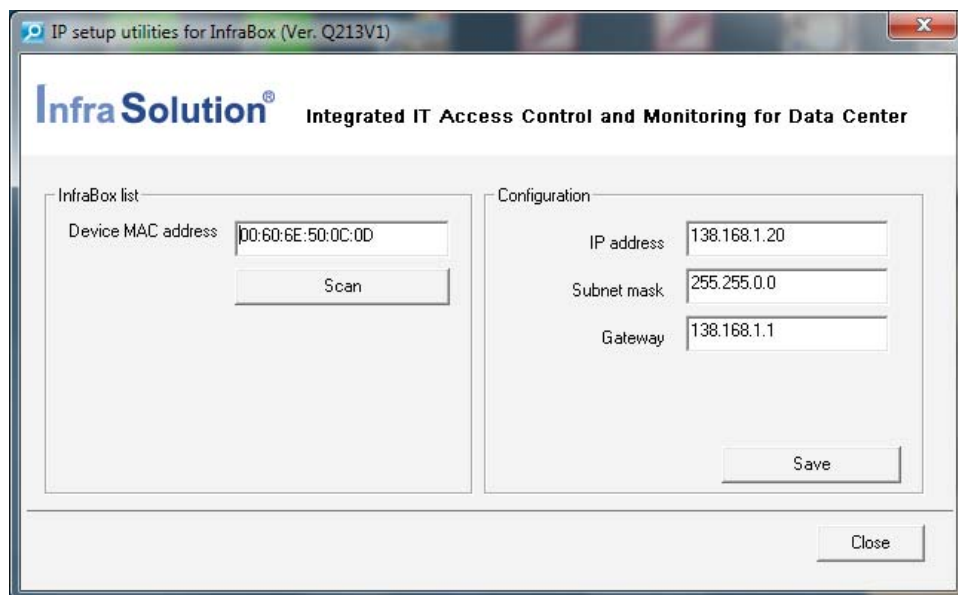
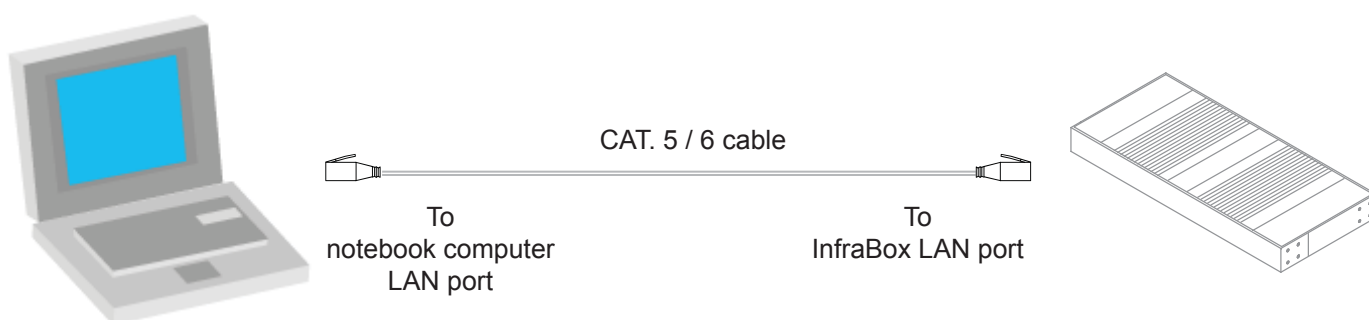

 Write down the new IP address for Part IX - < 9.2 > Cabinet Setup & Configuration

4. Click “ **Scan** ” to search the connected InfraBox.
5. Change the desired IP address / Subnet mask / Gateway, then Click “ **Save** ” to confirm the setting of InfraBox.
6. The default IP address is as below:
IP address: 138.168.1.20
Subnet mask: 255.255.0.0
Gateway: 138.168.1.1

Part VIII. Software Installation & Activation

< 8.1 > Hardware Requirements

Please prepare a **dedicated management PC** with the hardware requirements as below for

InfraSolution Manager - Martix Server

Recommended hardware :

For node 1 to 100 :

- Processor : Intel® Core™ i5 Processors 2.3GHz or above
- Memory : Min. 4GB Ram
- Available Disk Space : Min. 500GB SATA
- Optical drive : DVD-ROM Drive
- LAN Card : 100/1000Base-T NIC
- Display : Monitor with 1024 x 748 or higher resolution

For node over 100 :

- Processor : Dual CPU Intel® Xeon® Processor 5500 or 5600 Series or above
- Memory : Min. 8GB Ram
- Available Disk Space : Min. 1TB SATA
- Optical drive : DVD-ROM Drive
- LAN Card : 100/1000Base-T NIC
- Display : Monitor with 1024 x 768 or higher resolution

Supported OS platform list :

- MS Windows 7 Professional with SP1
- MS Windows 7 Ultimate with SP1
- MS Windows Server 2003 R2 Standard Edition with SP2
- MS Windows Server 2008 Standard Edition with SP2
- MS Windows Server 2008 R2 Standard Edition with SP1

Part VIII. Software Installation & Activation

< 8.2 > Software Installation

After the InfraBox installation, please take the following steps to install the

InfraSolution Manager - Matrix Server

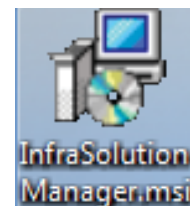

1. Download the **InfraSolution Manager - Matrix Server** to the management PC from the link :
[http://www.austin-hughes.com/support/software/infrasolution/InfraSolution Manager.msi](http://www.austin-hughes.com/support/software/infrasolution/InfraSolution%20Manager.msi)

2. Turn off “ **UAC Setting** “

Please visit the following link for the setting

<http://windows.microsoft.com/en-gb/windows7/turn-user-account-control-on-or-off>

3. **Restart Management PC**



Ensure users login the management PC as a member of “ Administrators “ Group before InfraSolution Manager installation and execution

4. Double click the **InfraSolution Manager.msi** and follow the instruction to complete the installation.

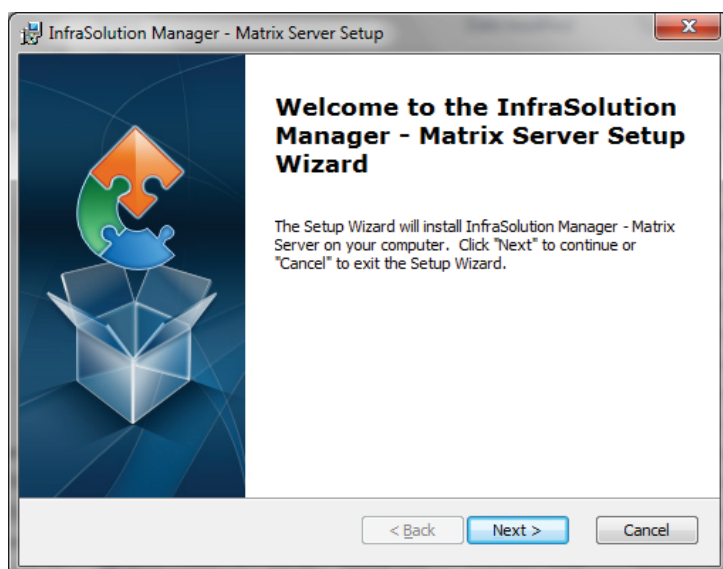

↓
click “ **Next** ”
↓
click “ **Install** ”
↓
click “ **Finish** ”

..... **Complete**

< 8.2 > Software Installation

PostgreSQL installation

After InfraSolution Manager installation, please take the following steps to install the “ **PostgreSQL** ”

Step 1.

Click “ **Start** ” & Click 

Step 2.

Click “ **Install PostgreSQL Server 9.2 64bit** ” for 64bit OS



For 32bit OS, Click “ **Install PostgreSQL Server 9.2 32bit** ”

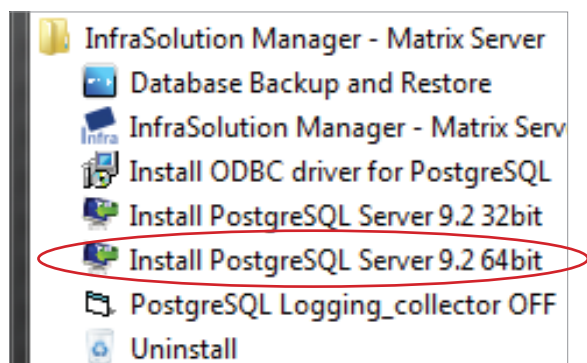

Step 3.

Click “ **Next** ”

Step 4.

Input the “ **PostgreSQL Installation Directory** ” & Click “ **Next** ” (Default: C:\postgres)

Step 5.

Input the “ **PostgreSQL Data Directory** ” & Click “ **Next** ” (Default: C:\postgres\data)

Step 6.

Input the “ **PostgreSQL password** ”, “ **retype password** ” & Click “ **Next** ” (Default: 1qaz2WSX)

Step 7.

Input the “ **Port no.** ” & Click “ **Next** ” (Default: 5432)

Step 8.

Select the “ **Locale** ” from the pull down menu & Click “ **Next** ” (Default: C)

Step 9.

Click “ **Next** ”

Step 10.

Untick the box & Click “ **Finish** ”

IMPORTANT NOTE :

User **MUST** use the default setting for step 8, otherwise,

- the operation of InfraSolution Manager will fail
- PostgreSQL and InfraSolution Manager **MUST** be uninstalled & reinstalled again

Part VIII. Software Installation & Activation

< 8.2 > Software Installation

ODBC driver installation for PostgreSQL

After “ PostgreSQL “ installation, please take the following steps to install the “ ODBC driver “

Step 1.

Click “ **Start** “& Click InfraSolution Manager - Matrix Server

Step 2.

Click “ **Install ODBC driver for PostgreSQL** “

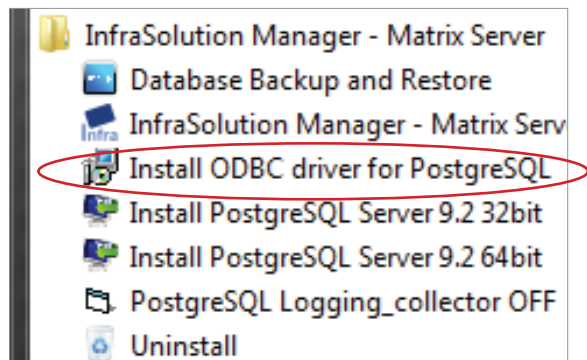

Step 3.

Tick License Agreement box & Click “ **Next** “

Step 4.

Click “ **Next** “

Step 5.

Click “ **Install** “

Step 6.

Click “ **Finish** “

..... **Complete**

< 8.2 > Software Installation

Data Execution Prevention Setup

After “ ODBC driver “ installation, please take the following steps to setup the “ Data Execution Prevention “



For Windows Server 2003 / 2008 32bit, 64bit and R2 version ONLY

Step 1.

Right Click “ Computer “ & Click “ Properties “

Step 2.

Click “ Advanced system settings “

Step 3.

Click “ Advanced “ & Click “ Settings... “

Step 4.

Click “ Add... “ from “ Data Execution Prevention “

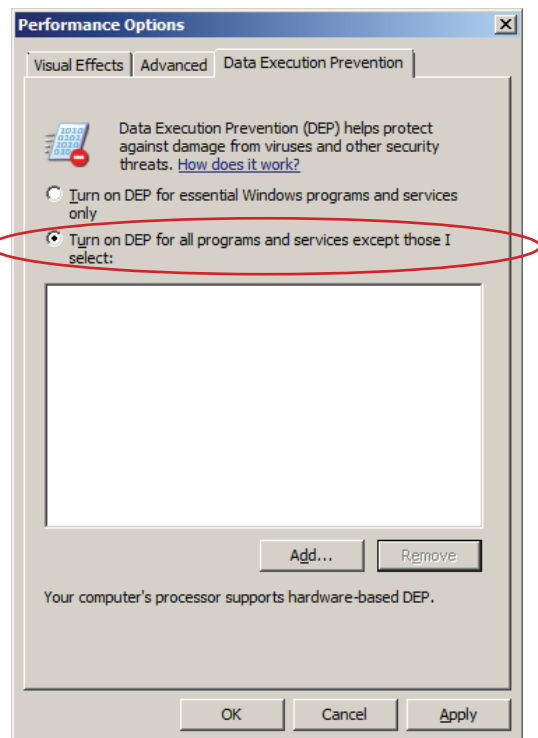

Step 5.

Select the first file as below & Click “ Open “

- 1 C:\Program Files(x86)\InfraSolution Manager - Matrix Server\InfraC.exe
- 2 C:\Program Files(x86)\InfraSolution Manager - Matrix Server\Services\SNMP\SNMPAgent.exe
- 3 C:\Program Files(x86)\InfraSolution Manager - Matrix Server\Services>EmailAlarmSrv\EmailAlarmSrv.exe
- 4 C:\Program Files(x86)\InfraSolution Manager - Matrix Server\Services\MFServer\THServer.exe
- 5 C:\Program Files(x86)\InfraSolution Manager - Matrix Server\Backup\IFSBackupEngine.exe
- 6 C:\Program Files(x86)\InfraSolution Manager - Matrix Server\Print\IFSPrintEngine.exe

Step 6.

Repeat step 4 & 5 for the remaining five files **One by One**

Step 7.

Click “ Apply “ & Click “ OK “

..... **Complete**

Part VIII. Software Installation & Activation

< 8.2 > Software Installation

First time database creation

After “ **Data Execution Prevention** ” setup, please take the following steps to create a new database for

InfraSolution Manager - Matrix Server



For MS Windows 7 and MS Windows server 2008, it requires to run a program with administrator rights before execution:

- Right Click **InfraSolution Manager - Matrix Server** , and then select “ **Properties** ”.
- Click the “ **Compatibility** ” tab.
- Tick the box “ **Run this program as an administrator** ”, and then Click “ **OK** ”.

Step 1.

Double click **InfraSolution Manager - Matrix Server**



Step 2.

Select “ **Celsius** ” or “ **Fahrenheit** ” in the temperature unit & Click “ **Setting** ”

Step 3.

Input “ **Port** ” & “ **Password** ” based on the value input in Step 7 & 6 in “ **PostgreSQL Installation** ” & Click “ **Next** ”

Step 4.

Select “ **Create a new database** ” & Click “ **Next** ”

Step 5.

Select “ **Initialize the database with default data** ” & Click “ **Next** ”

Step 6.

Click “ **Apply** ”

Step 7.

Click “ **Finish** ”

Step 8.

Click “ **OK** ”

< 8.3 > Software Activation

First time software activation

After database creation, please take the following steps to activate the

InfraSolution Manager - Matrix Server



- If users want to activate the software later,
 - Click “ **Evaluate** ” and go to “ **Part VIII. Setup & Operation** ” directly
 - Only 5 racks can be created in Evaluation period

Step 1.

Input the “ **Model** ”, “ **CD Key** ” in the “ **Product Activation** ” window

Step 2.

Click “ **Change Key** ” & the “ **Installation Key** ” will be generated automatically

Step 3.

Go to the Activation centre to get the “ **Activation Code** ”

of InfraSolution Manager - Matrix Server by clicking

“ **Activate InfraSolution Online** ” or visit

“ <http://www.infra-solution.com/activation> ”

Product Activation (Expired after 87 days)

Model: ISS-801-R5

CD Key: []

Installation Key: []

Activation Code: []

[Activate InfraSolution Online](#) or [Offline](#).

Inactivated

Evaluate License Activate Change Key

Step 4.

Input the “ **Model** ”, “ **CD Key** ”, “ **Installation Key** ”, “ **Company** ”, “ **E-mail** ” & “ **Contact Person** ” & Click “ **Submit** ”

Step 5.

The activation code generation takes a few seconds

Step 6.

Input the “ **Activation Code** ” to the “ **Product Activation** ” window & Click “ **Activate** ”

Step 7.

Click “ **Close** ” & Click “ **Close** ”

InfraSolution® Integrated IT Access Control and Monitoring over Ethernet

Product Activation

Welcome to the InfraSolution Online Activation Center!
In order to begin, you need to fill in the following information and get the Official Valid Activation Code.
If you already registered InfraSolution Product before, but you lost your activation code. Please [contact our support](#) directly.

* Model: ISS-801-R5

Description: License(User)1 Cabinet5

* CD Key: [] - [] - [] - [] - [] - []

* Installation Key: [] - [] - [] - [] - [] - [] - [] - []

Company: []

E-mail: []

Contact Person: []

Please complete all of the required fields (*) above before hitting the Submit button.

Submit Cancel

Part VIII. Software Installation & Activation

< 8.3 > Software Activation

Software license upgrade

If users want to upgrade “ **No. of Node** “, please order a license upgrade key & take the following steps to complete the software license upgrade.

Step 1.

In < **Setup** > page, Click “ **General** “

Step 2.

Click “ **CD Key** “ at lower right corner of the UI & the “ **Product Activation** “ window pops up

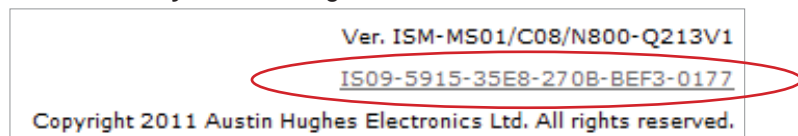

Step 3.

Input the “ **New Model no.** “ & “ **New CD Key** “

Step 4.

Follow the step 2 to 7 of “ **First time software activation** “ to complete the “ **Software license upgrade** “

Step 5.

Restart “ **InfraSolution Manager - Matrix Server** “

..... • **Complete**

Part IX. Setup & Operation

< 9.1 > Legend Definition

The legends below indicate different status of the cabinets in the software



Normal



Authorized
Open



Overdue
Warning



Disconnect



Unauthorized Door
Open



PDU Alarm



Heat Alarm

For Infra 840 and
2400 model only

< 9.2 > Cabinet Setup & Configuration

Step 1.

Connect the InfraBox to the management PC via the network device (hub or switch)

Step 2.

Make sure the InfraBox in power ON status

Step 3.

Make sure the cabinet door is closed

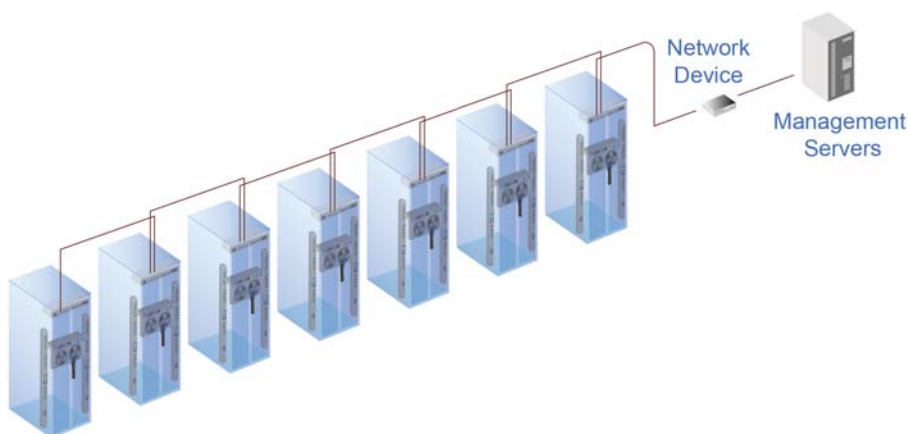

Step 4.

In < **Monitoring** > page, Click “ **Layout** “

Part IX. Setup & Operation

< 9.2 > Cabinet Setup & Configuration

Step 5.

Input “ Login name “ & “ Password “ in the pop up window & Click “ Yes “

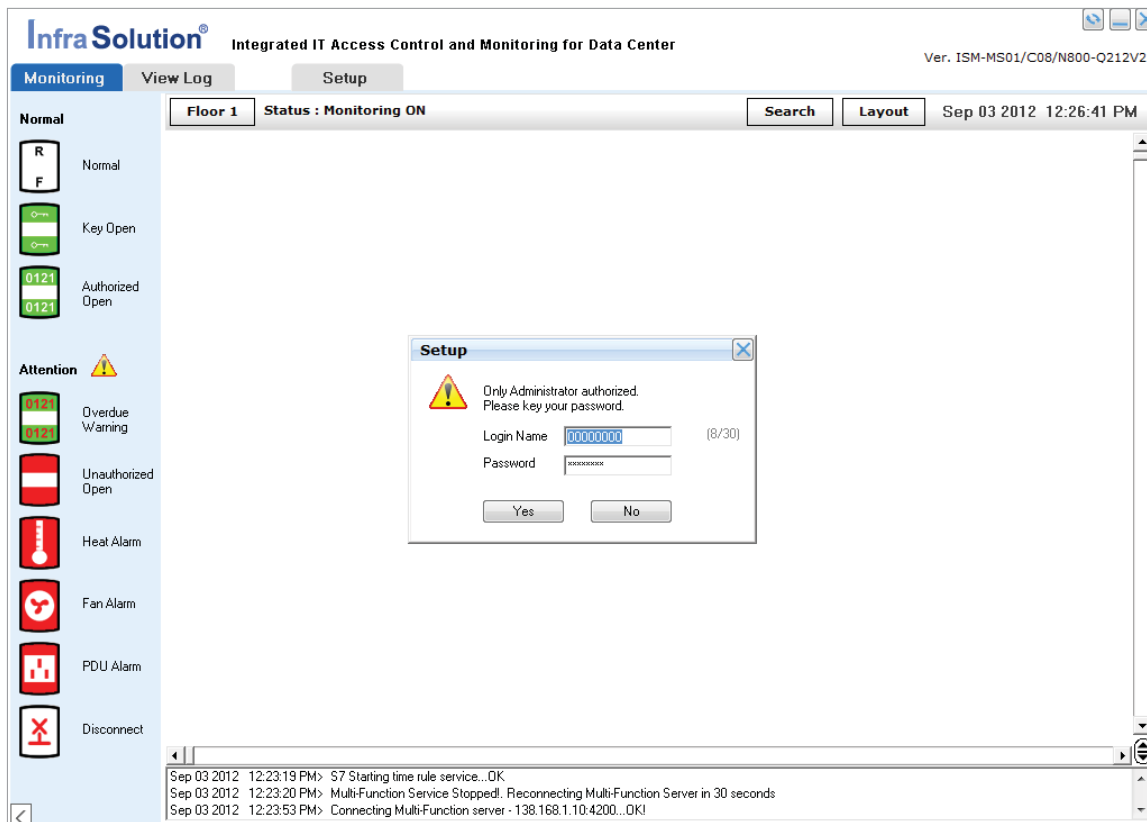

Step 6.

Click  /  /  to add 1 / 5 / 10 racks at one time

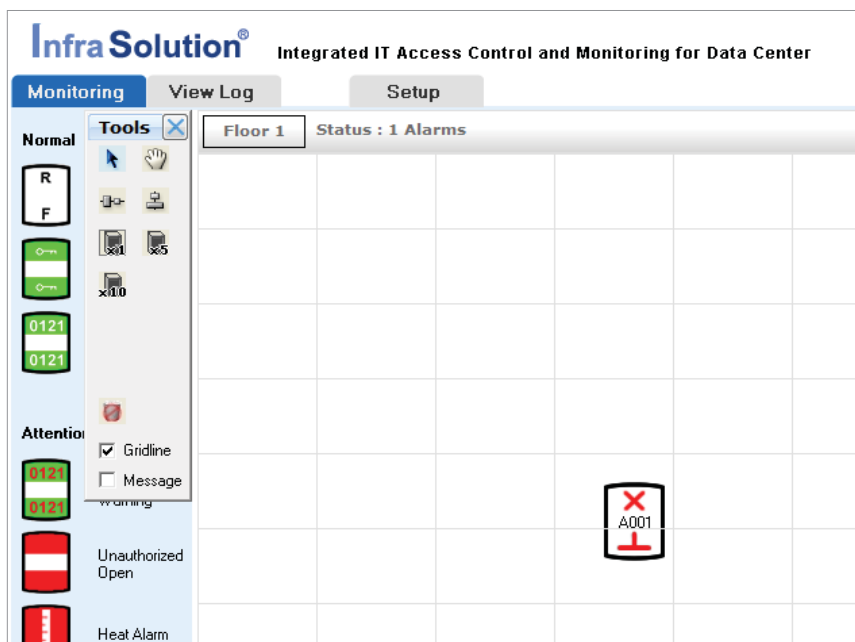

< 9.2 > Cabinet Setup & Configuration

Step 7.

Move mouse pointer to the Layout editor area & Click the mouse once and the new rack icon(s) will be shown

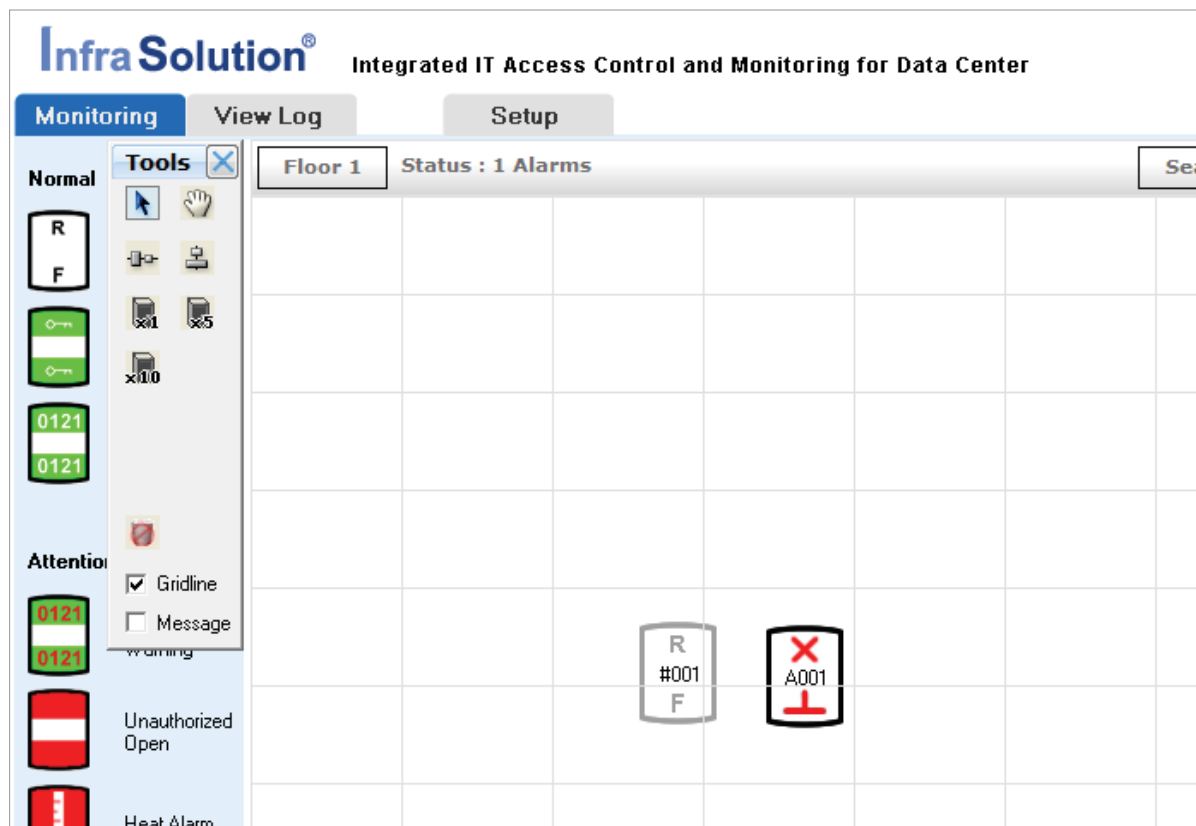

Step 8.

Click  in Tools box & Click "Yes" to save the cabinet assignment in Layout editor

Step 9.

Click < Setup >, input "Login name" & "Password" in the pop up window & Click "Yes"

Step 10.

Click "Rack" from the menu bar at the left hand side

Step 11.

Click the field of "Rack No." to edit the rack no.

Step 12.

Click the field of "Rack Name" to edit the rack name

Step 13.

Click "Search" in "InfraBox Address" & Click "Select"

Part IX. Setup & Operation

< 9.2 > Cabinet Setup & Configuration

Step 14.

Input IP address of the InfraBox into IP address field (e.g. 138.168.1.20) & Click “ **Test** ”

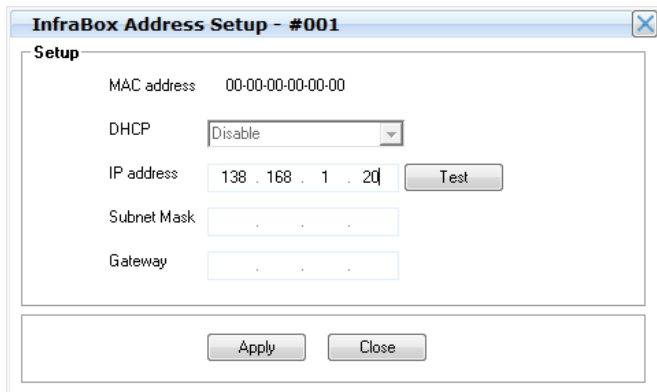

InfraBox Address Setup - #001

Setup

MAC address 00-00-00-00-00-00

DHCP Disable

IP address 138 . 168 . 1 . 20 Test

Subnet Mask

Gateway

Apply Close

Step 15.

“ **Searching...** ” takes a few seconds to complete

Step 16.

Click “ **Apply** ” after “ **MAC address** ”, “ **Subnet Mask** ” & “ **Gateway** ” are shown.

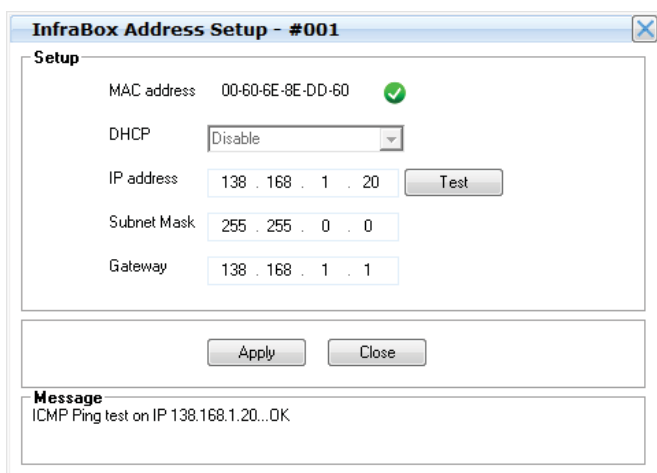

InfraBox Address Setup - #001

Setup

MAC address 00-60-6E-8E-DD-60 ✓

DHCP Disable

IP address 138 . 168 . 1 . 20 Test

Subnet Mask 255 . 255 . 0 . 0

Gateway 138 . 168 . 1 . 1

Apply Close

Message
ICMP Ping test on IP 138.168.1.20...OK

Step 17.

Click “ **Save** ”

 DON'T click any button before return to < **Setup** >

< 9.2 > Cabinet Setup & Configuration

Step 18.

Enable or Disable “ **Monitoring** ” to “ **Expansion Port** ” if necessary



DON'T enable “ **Expansion Port** ” for Infra 820 and 2200 model

DON'T enable TH1 or TH2 Alarm if no sensor installed

Step 19.

Click “ **Save** ” & Click “ **Yes** ” to complete the cabinet configuration

Rack No.	#001	Authorized Rack User List	
Rack Name	New Rack #001	<input type="button" value="Add"/>	<input type="button" value="Clone From Other"/>
InfraBox Address	00-60-6E-8E-DD-60	<input type="button" value="Delete"/>	<input type="button" value="Delete All"/>
	IP Address :138.168.1.20	<input checked="" type="checkbox"/> Show Card ID for the User	
	Subnet Mask :255.255.0.0	User Name	Card ID
	Gateway :138.168.1.1		
	DHCP :Disable		
Floor	Floor 1		
Key Lock No.	Nil		
Direction	Vertical R/F		
Monitoring	Enable		
Audio Alarm	Disable		
Email Alarm	Disable		
TH 1 Alarm	Disable		
TH 2 Alarm	Disable		
Expansion Port	Enable		
SNMPv3	1550.1.10.1.2		

Total authorized : 0

Please click on the text to edit the rack data

1/2

Step 20.

Repeat step 11 to 19 for other InfraBoxes **One by One**

Part IX. Setup & Operation

< 9.3 > User Setup & Configuration

User Comparison

Features	Operator	Administrator	Key Administrator
Rack Status Monitoring	✓	✓	✓
Rack Setup & Configuration		✓	✓
Card Assignment		✓	✓
Individual Remote Handle Control		✓	✓
Layout (Rack Icon Addition & Removal)		✓	✓
Time Zone & Time Rule Setting		✓	✓
Key Administrator Setup			✓
Administrator Setup			✓
Operator Setup		✓	✓
Visitor Setup		✓	✓
Rack Re-Connection	✓	✓	✓
* Temp-Humid Alarm Setting		✓	✓
*# Individual Outlet Switch ON / OFF		✓	✓
*# PDU Amp. Alarm Setting		✓	✓
SNMP Setup		✓	✓
View Log Record & Export	✓	✓	✓
Backup / Restore	✓	✓	✓
Floor Plan Background		✓	✓
E-Mail Alarm Setup		✓	✓
Overdue Warning Setting		✓	✓
Temperature Unit Modification °C / °F		✓	✓
License Upgrade		✓	✓

* For Infra 840 or 2400 Model only

For MTS PDU only

< 9.3 > User Setup & Configuration

The software provides 4 types of users :

- Key Administrator
- Administrator
- Operator
- Visitor

Only key administrator & administrator can login to the software.

InfraSolution® Integrated IT Access Control and Monitoring for Data Center
Ver. ISM-MS01/C08/N800-Q212V2

Monitoring View Log **Setup** Sep 04 2012 11:56:29 AM

General
Rack
Key Administrator
Administrator
Operator
Visitor

First Name KeyAdmin (8/30)
Last Name Tester1
Title Director
Staff No. AH123456789
Mobile No. (+852) 87654321
Tel. No. (+825) 12345678
Email tester.1@austin-hughes.com
Dept. R&D
Company Austin Hughes
Time Rule Time Rule 7 (all time allow access)

Card No. 00026147
Issue Date Jan 01 2011
Expiry Date Dec 31 2015

Login Name 00000000
Password *****
Retype Password *****

Assigned Rack List
Add Clone From Other
Delete Delete All
 Show Rack Name

Rack No.	Rack Name
----------	-----------

Total authorized : 0

Please click on the text to edit the user data

<Previous Save Delete New Next>
1 / 1 Search Print View All

Sep 04 2012 11:54:23 AM> User=KeyAdmin Tester1 [UID20090206095938-6762] from server console. Accessing Matrix Server [Setup] page...OK EventID [SA]
Sep 04 2012 11:56:12 AM> User=KeyAdmin Tester1 [UID20090206095938-6762] from server console. Leaving Matrix Server [Setup] page...OK EventID [EOK]
Sep 04 2012 11:56:25 AM> User=KeyAdmin Tester1 [UID20090206095938-6762] from server console. Accessing Matrix Server [Setup] page...OK EventID [SA]

Key Administrator

Step 1.

In < Setup > page, Click “ Key Administrator “

Step 2.

Input “ First Name “ to “ Company “

Step 3.

Select “ Time Rule “ which determines when the user can open cabinet door by the smartcard

Step 4.

Input “ Login name “ , “ Password “ & “ Retype Password “

Step 5.

Assign “ Card no. “ , & Select “ Issue Date “ & “ Expiry Date “ of the smartcard

Step 6.

Click “ Save “

Step 7.

Repeat Step 2 to 6 for other Key Administrators **One by One**

Part IX. Setup & Operation

< 9.3 > User Setup & Configuration

Administrator

Step 1.

In < **Setup** > page, Click “ **Administrator** “



Other Steps same as step 2 to 7 of Key Administrator Setup

Operator

Step 1.

In < **Setup** > page, Click “ **Operator** “



Other Steps same as step 2, 3, 5, 6 & 7 of Key Administrator Setup

Visitor

Step 1.

In < **Setup** > page, Click “ **Visitor** “

Step 2.

Input “ **First Name** “ to “ **Address** “

Step 3.

Assign “ **Card no.** “

Step 4.

Select “ **Visit Date & Time** “, “ **Duration** “, & “ **Leave Date & Time** “

Step 5.

Click “ **Save** “

Step 6.

Repeat Step 2 to 5 for other Visitors One by One



To assign card no., users should

- make sure the mouse pointer at “ **Card No.** “ field
- present the smartcard to the card reader connected to the management PC

< 9.4 > Card Assignment

After < **User Setup & Configuration** >, please take the following steps to assign smartcard to the Cabinet

Step 1.

In < **Setup** > page, Click “ **Rack** ”

Step 2.

Click “ **Add** ”

Step 3.

Select “ **Card no.** ” from the “ **Add Authorized User** ”

 (Tick “ **Select all** ” if user wants to assign all smartcards “)

Step 4.

Click “ **Add** ” & then “ **Close** ”

Step 5.

Click “ **Save** ” to complete the card assignment

Step 6.

Repeat Step 2 to 6 for other cabinets **One by One**

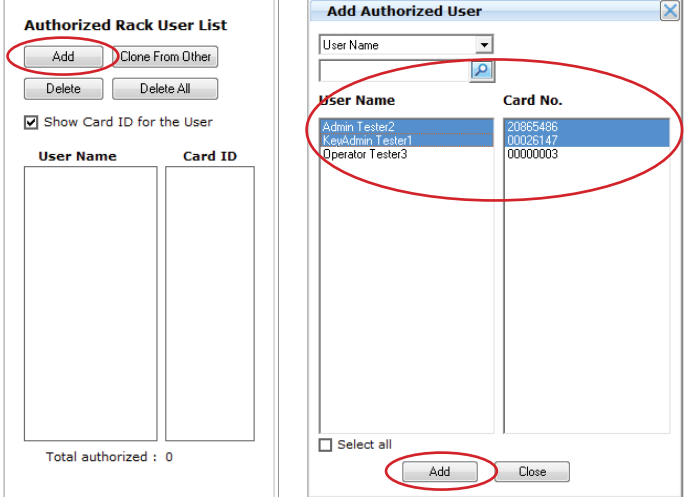

Authorized Rack User List

Add Clone From Other

Delete Delete All

Show Card ID for the User

User Name	Card ID
-----------	---------

Total authorized : 0

Add Authorized User

User Name

User Name Card No.

Admin Tester2	20865486
Kevin Admin Tester1	00106147
Operator Tester3	00000003

Select all

Add Close

Card Delete

Step 1.

Select “ **Card ID** ” from “ **Authorized Rack User List** ”

Step 2.

Click “ **Delete** ” & Click “ **Yes** ” from the pop up window

 (Click “ **Delete All** ” if user wants to unassign all smartcards “)

Step 3.

Click “ **Save** ”

Step 4.

Repeat Step 1 to 3 for other cabinets **One by One**



Authorized Rack User List

Add Clone From Other

Delete Delete All

Show Card ID for the User

User Name	Card ID
Louis Yiu	20616606
Mike wong	20772238
Toby Law	20732014
Tom Li	20895742

Total authorized : 4

Part IX. Setup & Operation

< 9.5 > Monitoring & Control of Cabinet

To monitor & control a cabinet, users can double click the “ **Rack Icon** ”  in “ **Monitoring** ” page

Rack Info.

Click “ **Details** ”, view the real time configuration of the cabinet

Door Status

Click “ **Details** ”, view the door access log for the smartcard/key open / close history recorded during the time period selected

Remote Handel Control

Click “ **Details** ”, view the door access log for the software remote opening

Click “ **Release** ” to open the door remotely

Click “  ”, define the door remote open time (min. 10 sec, max. 999 sec)

*** Environmental**

Click “ **Detail** ”, view the line chart of the TH readings

***# Expansion Ports**

Click “ **Details** ”, view the PDU status log during the time period selected

Click “ **Device** ” name :

- view the amp. reading & set the alarm level of PDU
- remote switch on / off individual outlet of PDU (MTS only)

* For Infra 840 or 2400 Model only

For MTS PDU only

< 9.6 > Log Record & Report

< View Log >, provides

- device events in daily, weekly, monthly & yearly basis.
- application log in daily basis
- export of device events & application log in text format

Part X. General System Setup

< 10.1 > Floor Plan Background / Warning / Temperature Unit

“ **Background** “ provides total four floor plan background. User can insert one floor plan image in “ .jpg “ & “ .jpeg “ format one at a time for each floor.

Step 1.

In < **Setup** > page, Click “ **General** “

Step 2.

Click the field of “ **Specify a blueprint for Floor 1 :** “

Step 3.

Click 

Step 4.

Select floor plan image & Click “ **Open** “

Step 5.

Click “ **Save** “

Step 6.

Repeat the above steps for other backgrounds if necessary

“ **Warning** “ provides a overdue notice shown on the rack icon (1 ~ 9999 mins)

“ **Temperature Unit** “ allows user to change the temp unit display in °C / °F

Part X. General System Setup

< 10.2 > Database Management

It provides a way for database management of InfraSolution Manager - Matrix Server when users want

- monitor racks created from other database
- create a new database

Please take the following steps to complete the database import or new database creation

Step 1.

In < **Setup** > page, Click “ **General** “

Step 2.

Click “ **Management...>** “ in “ **Database** “

Step 3.

Click “ **Setup** “ in “ **Database Connection Setup** “ window

Step 4.

Click “ **Setting** “

Step 5.

Input “ **Login name** “ & “ **Password** “ from the pop up window

Step 6.

Click “ **Next** “ in “ **Database Initialization** “ window

Step 7.

Select “ **Select from existing database server** “ in “ **Data Import** “ window



To create a new database, please select “ **Create a new database** “

Step 8.

Select the database you want to import in the pull down menu of “ **Database name** “



Provide the new “ **Database name** “ , “ **User name** ” & “ **Password** “ if select “ **Create a new database** “ in step 7

Step 9.

Input “ **User name** “ & “ **Password** “ of this database & Click “ **Next** “

Step 10.

Select “ **Import and use the existing database in the database** “ & Click “ **Next** “



Select “ **Initialize the database with default data** “ if select “ **Create a new database** “ in step 7

Step 11.

Click “ **Apply** “ & Click “ **Finish** “

Step 12

Click “ **Test** “ in “ **Database Connection Setup** “ window

Step 13.

Click “ **Close** “ in “ **Connection Test** “ window after connection test is successful

Step 14.

Click “ **Apply** “

Step 15.

Click “ **Yes** “ to restart the InfraSolution Manager - Matrix Server

< 10.3 > Services Setup (Software SNMP / Email)

Software SNMP

Step 1.

In < **Setup** > page, Click “ **Setup...>** “ in “ **Services** “

Step 2.

Select “ **SNMP** “ & Click “ **Setup**”

Step 3.

Select “ **Enable** “ in “ **SNMP Agent** “, Click “ **Apply** “ & Click “ **Yes** “

Step 4.

Click “ **Start** “ & Click “ **Yes** “

Step 5.

Click “ **Close** “ & Click “ **Close** “

Step 6.

Get the *.mib file from “ **C:\Program Files (x86)\InfraSolution Manager - Matrix Server\Services\SNMP\MIB** “

Email

Step 1.

In < **Setup** > page, Click “ **Setup...>** “ in “ **Services** “

Step 2.

Select “ **Email** “ & Click “ **Setup**”

Step 3.

Click “ **Setup** “ & Input all the necessary information from “ **Server IP** “ to “ **CC** “ in this page

Step 4.

Click “ **Apply** “ & “ **Yes** “

Step 5.

Click “ **Close** “ & Click “ **Close** “

Part X. General System Setup

< 10.4 > Time Zone / Time Rule

System provides 8 “ **Time Zone** “. Single or groups of time zone can be used to form an effective access time for rack called “ **Time Rule** “

Time Zone

Step 1.

In < **Setup** > page, Click “ **Time Zone** “

Step 2.

Input the “ **Description** “, select “ **time period** ” & tick the desirable “ **Days of the Week** “ for Zone No. 1

Step 3.

Repeat step 1 & 2 for Zone No. 2 to 7 if necessary



Click “ **Reset** “ if user wants to cancel the modification

Step 4.

Click “ **Save** “

< **Time Sync.** > synchronizes the real time clock of InfraBox(es) from the system time of the management PC

Step 1.

In < **Time Zone** >, Click “ **Time Sync.** “

Step 2.

Click “ **Read** “ to read the system time of the management PC

Step 3.

Tick the InfraBoxes you want to update the real time clock (Tick “ **Select all** “ for all connected InfraBoxes)

Step 4.

Click “ **Update** “

Zone No.	Description	Time	All days	Sun	Mon	Tue	Wed	Thu	Fri	Sat
1	Office Hour (Day Time: Mon-Fri)	From 09:00 To 18:15	<input checked="" type="checkbox"/>	<input type="checkbox"/>	<input checked="" type="checkbox"/>	<input checked="" type="checkbox"/>	<input checked="" type="checkbox"/>	<input checked="" type="checkbox"/>	<input checked="" type="checkbox"/>	<input type="checkbox"/>
2	Office Hour (Day Time: Sat)	From 09:00 To 13:15	<input checked="" type="checkbox"/>	<input type="checkbox"/>	<input type="checkbox"/>	<input type="checkbox"/>	<input type="checkbox"/>	<input type="checkbox"/>	<input type="checkbox"/>	<input checked="" type="checkbox"/>
3	Day Time	From 00:00 To 18:00	<input checked="" type="checkbox"/>	<input checked="" type="checkbox"/>	<input checked="" type="checkbox"/>	<input checked="" type="checkbox"/>	<input checked="" type="checkbox"/>	<input checked="" type="checkbox"/>	<input checked="" type="checkbox"/>	<input checked="" type="checkbox"/>
4	Night Time	From 18:00 To 23:59	<input checked="" type="checkbox"/>	<input checked="" type="checkbox"/>	<input checked="" type="checkbox"/>	<input checked="" type="checkbox"/>	<input checked="" type="checkbox"/>	<input checked="" type="checkbox"/>	<input checked="" type="checkbox"/>	<input checked="" type="checkbox"/>
5	No Time Restriction (Mon - Fri)	From 00:00 To 23:59	<input checked="" type="checkbox"/>	<input type="checkbox"/>	<input checked="" type="checkbox"/>	<input checked="" type="checkbox"/>	<input checked="" type="checkbox"/>	<input checked="" type="checkbox"/>	<input checked="" type="checkbox"/>	<input type="checkbox"/>
6	Time Rule 6	From 00:00 To 23:59	<input checked="" type="checkbox"/>	<input checked="" type="checkbox"/>	<input checked="" type="checkbox"/>	<input checked="" type="checkbox"/>	<input checked="" type="checkbox"/>	<input checked="" type="checkbox"/>	<input checked="" type="checkbox"/>	<input checked="" type="checkbox"/>
7	Time Rule 7	From 00:00 To 23:59	<input checked="" type="checkbox"/>	<input checked="" type="checkbox"/>	<input checked="" type="checkbox"/>	<input checked="" type="checkbox"/>	<input checked="" type="checkbox"/>	<input checked="" type="checkbox"/>	<input checked="" type="checkbox"/>	<input checked="" type="checkbox"/>
8	No Time Restriction	From 00:00 To 23:59	<input checked="" type="checkbox"/>	<input checked="" type="checkbox"/>	<input checked="" type="checkbox"/>	<input checked="" type="checkbox"/>	<input checked="" type="checkbox"/>	<input checked="" type="checkbox"/>	<input checked="" type="checkbox"/>	<input checked="" type="checkbox"/>

Time Sync. Save Reset Close

< 10.4 > Time Zone / Time Rule

System provides 7 **Time Rules** for users to access the cabinet through smartcard

Time Rule

Step 1.

In < **Setup** > page, Click “ **Time Rule** “

Step 2.

Click “ **Selected time zone** “

Step 3.

For example, Tick “ **Zone 1** “ & “ **Zone 2** “ for Rule 1



Click “ **Reset** “ if user wants to cancel the modification

Step 4.

Click “ **Save** “

Step 5.

Repeat the steps above for other rules if necessary

	Sunday	Monday	Tuesday	Wednesday	Thursday	Friday	Saturday
<input checked="" type="checkbox"/> Zone 1	/	09:00-18:15	09:00-18:15	09:00-18:15	09:00-18:15	09:00-18:15	/
<input checked="" type="checkbox"/> Zone 2	/	/	/	/	/	/	09:00-13:15
<input type="checkbox"/> Zone 3	00:00-18:00	00:00-18:00	00:00-18:00	00:00-18:00	00:00-18:00	00:00-18:00	00:00-18:00
<input type="checkbox"/> Zone 4	18:00-23:59	18:00-23:59	18:00-23:59	18:00-23:59	18:00-23:59	18:00-23:59	18:00-23:59
<input type="checkbox"/> Zone 5	/	00:00-23:59	00:00-23:59	00:00-23:59	00:00-23:59	00:00-23:59	/
<input type="checkbox"/> Zone 6	00:00-23:59	00:00-23:59	00:00-23:59	00:00-23:59	00:00-23:59	00:00-23:59	00:00-23:59
<input type="checkbox"/> Zone 7	00:00-23:59	00:00-23:59	00:00-23:59	00:00-23:59	00:00-23:59	00:00-23:59	00:00-23:59
<input type="checkbox"/> Zone 8	00:00-23:59	00:00-23:59	00:00-23:59	00:00-23:59	00:00-23:59	00:00-23:59	00:00-23:59

Buttons: Save, Reset, Close

Part XI. Backup & Restore

Backup

Step 1.

Click “ **Start** ” & Click InfraSolution Manager - Matrix Server

Step 2.

Click “ **Database Backup and Restore** ”

Step 3.

Right Click  from the system tray & Click “ **Show** ”

Step 4.

Select “ **Backup** ” and tick the backup option as necessary

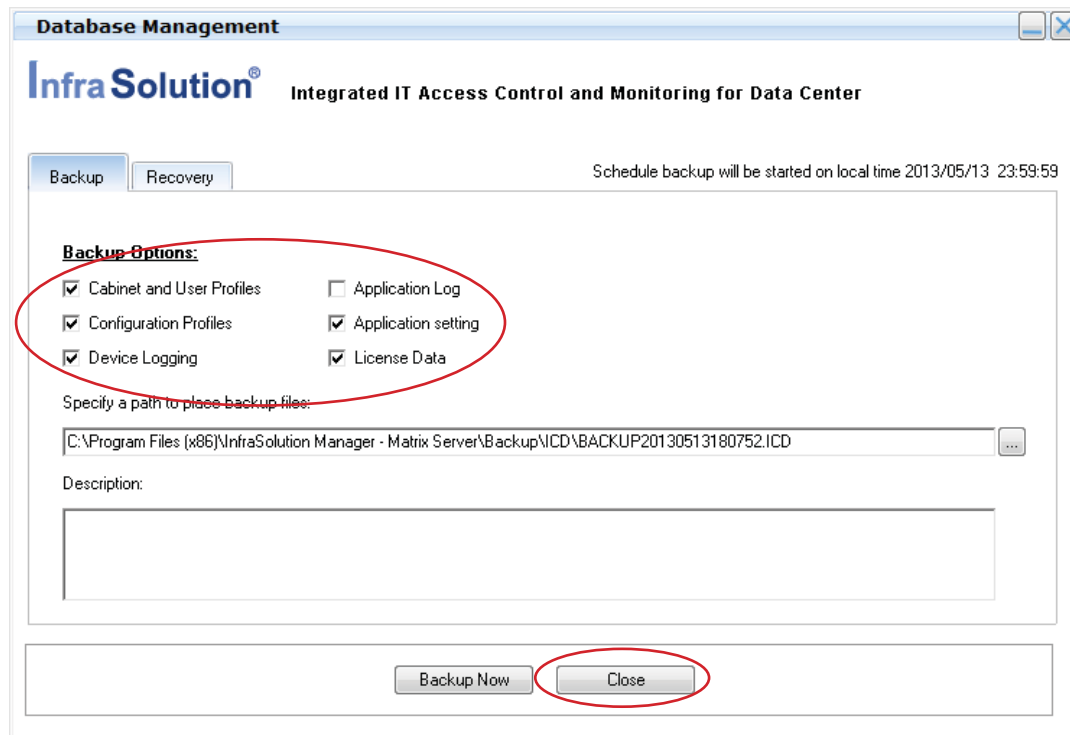

Step 5.

Specify the path of backup file (Default: “ C:\Program Files (x86)\InfraSolution Manager - Matrix Server\Backup\ICD ”)

Step 6.

Click “ **Backup Now** ”

Step 7.

Click “ **Close** ”

Restore

Step 1.

Close

Step 2.

Click " " to find the backup file in " **Recovery** "

(Default: " C:\Program Files (x86)\InfraSolution Manager - Matrix Server\Backup\ICD ")

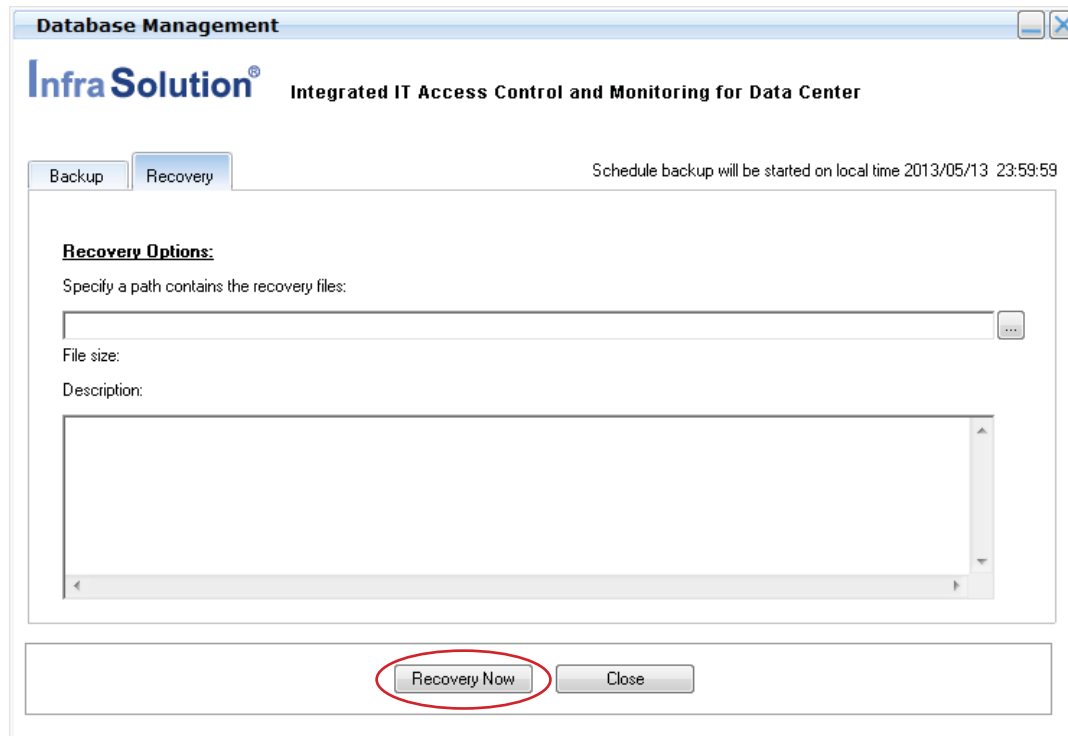

Step 3.

Click " **Recovery Now** "

Step 4.

Click " **Close** "

Step 5.

Restart

InfraSolution Manager – Matrix Server

1. What is InfraSolution Manger – Matrix Server ?

InfraSolution Manager provides a simple graphic user interface (GUI) to centralize the management of a large number of data center server cabinets in remote locations across Ethernet TCP/IP networks. It is basically the engine of InfraSolution and is designed to provide intelligent secure physical layer card access that remotely releases cabinet locking handles as well as centralized management for control, reporting and audit purposes. When using the InfraBox 2400 series, the InfraSolution Manager also allows GUI remote management for intelligent PDUs.

2. What OS does the software support ?

- MS Windows 7 Professional with SP1
- MS Windows 7 Ultimate with SP1
- MS Windows Server 2003 R2 Standard Edition with SP2
- MS Windows Server 2008 Standard Edition with SP2
- MS Windows Server 2008 R2 Standard Edition with SP1

3. What language does the software support ?

- English

4. What is the minimum required resolution of LCD monitor ?

- 1024 x 768. Otherwise, the software is not allowed to install

5. Which database does the software use ?

- PostgreSQL 64 bit for 64bit OS
- PostgreSQL 32 bit for 32bit OS

6. What is the PostgreSQL default password for the software ?

- 1qaz2WSX

7. Which are the default ports used in the software ?

- UDP port: 8888, 8890 & 5300 for searching InfraBox
- UDP port: 161 & 162 for SNMP communication
- TCP port: 4000 & 4001 for InfraBox communication
- TCP port: 25, 110 & 995 for email alarm service

8. “ Could not connect to the server “ when the software starts up ?

- Make sure the PostgreSQL services is started
(Control Panel -> Administrative Tools -> Services -> postgresql-9.x – PostgreSQL Server 9.x)

9. How to reconnect the disconnected cabinet ?

- Click “ **Status: xx Alarms** “ in “ **Monitoring** “ page & Click “ **Reconnect all** “

Part XIII. Troubleshooting

1. GUI shows a certain InfraBox disconnected

Step 1 - InfraBox power off ?

Check the InfraBox is power ON or not

Step 2 - Cat. 5 / 6 cable disconnected, loose or defective ?

Check the Cat. 5 / 6 cable connection to InfraBox and network devices. Make sure the connectors are firmly attached. And check if any defects on your cable or not. If yes, replace a new one.

Step 3 - Can ping the IP address ?

Make sure the IP address is configured using the “ **IP setup utilities for InfraBox** “

Step 4 - “ **Monitoring** “ of the InfraBox disabled in “ **Setup** “ page?

Make sure “ **Monitoring** “ is enabled

2. Why error shows as below during first time database creation ?

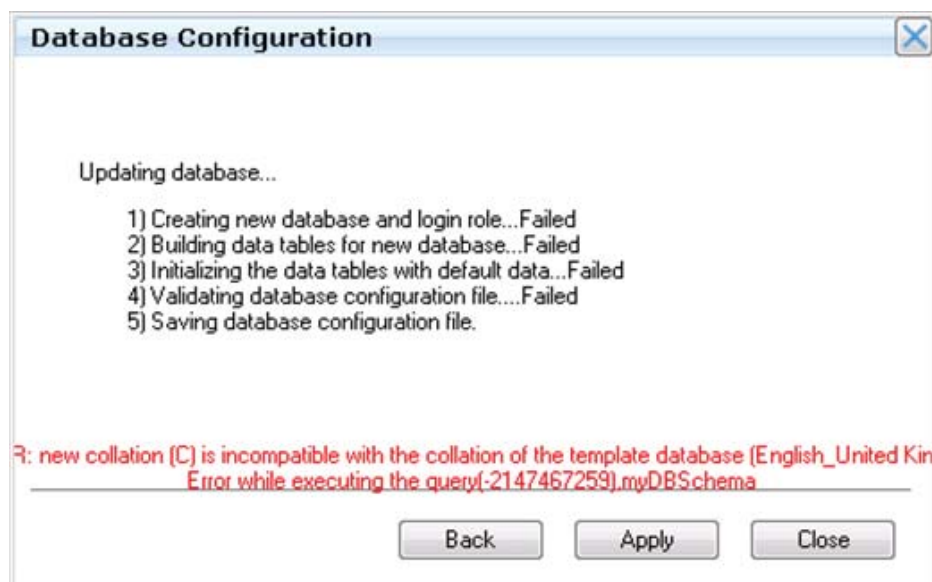

Step 1. Click “ **Close** “

Step 2. Go to “ **Control Panel** “ -> “ **Programs and Features** “

Step 3. Select “ **PostgreSQL 9.x** “ & Click “ **Uninstall/Change** “

Step 4. Click “ **Yes** “

Step 5. Click “ **Ok** “

Step 6. Click “ **Ok** “

Step 7. Click “ **No** “

Step 8. Go to C:\ to delete “ **postgres** “ folder

Step 9. Restart the management PC

Step 10. Repeat user manual Part VIII < 8.2 > Software Installation “ PostgreSQL installation “



Make sure select “ **C** “ from the pull down menu of “ **Locale** “

Part XIV. Optional Accessories

Temperature & Humidity sensor, pc (IG-TH01)

- One sensor for both temperature and humidity
- Low profile and light weight design with a magnetic base for easy affixing to the cabinet

Individual key lock, set of two for front & rear door (ISK-C051)

- Up to 500 individual key-locks available

Unique key lock (ISK-UKL)

- Unique key dedicated to single project / customer regionally
- For project size over 500 cabinets

Proximity smartcard, pack of 10 (ISC-P10)

- Proximity 26-bit format
- Single card for multiple application
- Custom card layout available

MiFARE smartcard, pack of 10 (ISC-M10)

- MiFARE 26-bit format
- Single card for multiple application
- Custom card layout available

Proximity card reader (ISC-PCR)

- Proximity 26-bit smartcard compatible
- Convenient way for smartcard ID reading
- Driverless for easy installation

MiFARE card reader (ISC-MCR)

- MiFARE 26-bit smartcard compatible
- Convenient way for smartcard ID reading
- Driverless for easy installation

The company reserves the right to modify product specifications without prior notice and assumes no responsibility for any error which may appear in this publication.

All brand names, logo and registered trademarks are properties of their respective owners.

Copyright 2013 Austin Hughes Electronics Ltd. All rights reserved.