

Installation Manual



Split System Heat Pump
Sizes 018–060

PH10
PH12

NOTE: Read the entire instruction manual before starting the installation.

SAFETY CONSIDERATIONS

Improper installation, adjustment, alteration, service, maintenance, or use can cause explosion, fire, electrical shock or other conditions which may cause personal injury or property damage. Consult a qualified installer, service agency or your distributor or branch for information or assistance. The qualified installer or agency must use factory-authorized kits or accessories when modifying this product. Refer to the individual instructions packaged with the kits or accessories when installing.

Follow all safety codes. Wear safety glasses and work gloves. Use quenching cloth for brazing operations. Have fire extinguisher available. Read these instructions thoroughly and follow all warnings or cautions attached to the unit. Consult local building codes and the National Electrical Code (NEC) for special installation requirements.

Recognize safety information. This is the safety-alert symbol \triangle . When you see this symbol on the unit or in instructions and manuals, be alert to the potential for personal injury.

Understand the signal words DANGER, WARNING, and CAUTION. These words are used with the safety-alert symbol. DANGER identifies the most serious hazards which **will** result in severe personal injury or death. WARNING signifies hazards which **could** result in personal injury or death. CAUTION is used to identify unsafe practices which **would** result in minor personal injury or product and property damage. NOTE is used to highlight suggestions which **will** result in enhanced installation, reliability, or operation.

\triangle **WARNING:** Before installing or servicing system, always turn off main power to system. There may be more than 1 disconnect switch. Lock out and tag switch with a suitable warning label. Turn off accessory heater power if applicable. Electrical shock can cause personal injury or death

INSTALLATION

PROCEDURE 1—CHECK EQUIPMENT AND JOB SITE

A. Unpack Unit

Move to final location. Remove carton taking care not to damage unit.

B. Inspect Equipment

File claim with shipping company, prior to installation, if shipment is damaged or incomplete. Locate unit rating plate on unit service panel. It contains information needed to properly install unit. Check rating plate to be sure unit matches job specifications.

C. Check Defrost Thermostat

Check defrost thermostat to ensure it is properly located and securely attached. A liquid header with a brass distributor and feeder tube goes into outdoor coil. At the end of 1 of the feeder tubes, there is a 3/8-in. OD stub tube approximately 3 in. long. The defrost thermostat should be located on stub tube. Note that only 1 stub tube is used with liquid header, and on most units it is the bottom circuit.

D. Installation Recommendations

NOTE: In some cases noise in living area has been traced to gas pulsations from improper installation of equipment.

1. Locate unit away from windows.
2. Ensure that vapor and liquid tube diameters are appropriate to capacity of unit. (See Table 1.)
3. Run refrigerant tubes as directly as possible by avoiding unnecessary turns and bends.
4. Leave some slack between structure and unit to absorb vibration.
5. When passing refrigerant tubes through wall, seal opening with RTV or other pliable silicon-based caulk. (See Fig. 1.)
6. Avoid direct tubing contact with water pipes, ductwork, floor joists, wall studs, floors, and walls.
7. Do not suspend refrigerant tubing from joists and studs with a rigid wire or strap which comes in direct contact with tubing. (See Fig. 1.)
8. Ensure that tubing insulation is pliable and it completely surrounds vapor tube.
9. When necessary, use hanger straps which are 1-in. wide and conform to shape of tubing insulation. (See Fig. 1.)

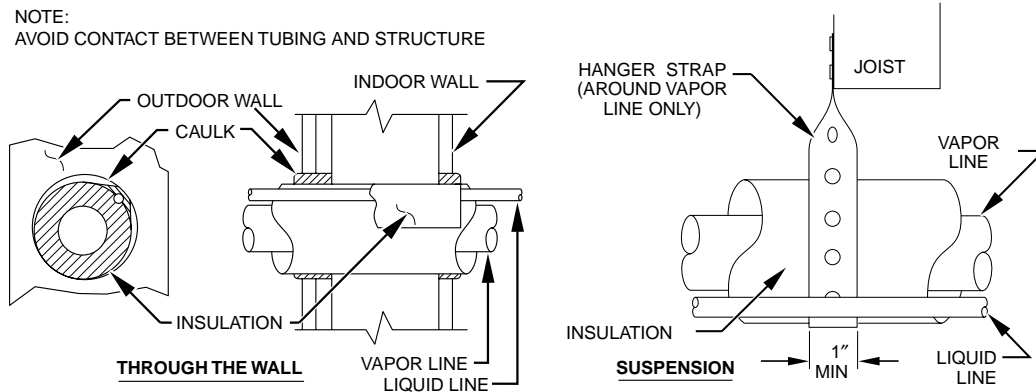

A01443

Fig. 1—Piping Installation

Table 1—Refrigerant Connections and Recommended Liquid and Vapor Tube Diameters (In.)

UNIT SIZE		LIQUID		VAPOR	
PH10	PH12	Connect Diameter	Tube Diameter	Connect Diameter	Tube Diameter
018, 024	018	3/8	3/8	5/8	5/8
030, 036	024–036	3/8	3/8	3/4	3/4
042, 048	042, 048	3/8	3/8	7/8	7/8
060	060	3/8	3/8	7/8	1-1/8

NOTE: Tube diameters are for lengths up to 50 ft. For tubing lengths greater than 50 ft, consult your local distributor.

10. Isolate hanger straps from insulation by using metal sleeves bent to conform to shape of insulation.

PROCEDURE 2—INSTALL ON A SOLID, LEVEL MOUNTING PAD

If conditions or local codes require unit be attached to pad, tie-down bolts should be used and fastened through knockouts provided in unit base pan. Refer to unit mounting pattern in Fig. 2 to determine base pan size and knockout hole location. For minimum pad dimensions see Fig. 2.

When installing, allow sufficient space for airflow clearance, wiring, refrigerant piping, and service. Allow 30-in. clearance to service end of unit and 48 in. above unit. For proper airflow, a 6-in. clearance on 1 side of unit and 12 in. on all remaining sides must be maintained. Maintain a distance of 24 in. between units. Discharge air must be unobstructed and must not recirculate. Position so water, snow or ice from roof or eaves cannot fall directly on unit. On rooftop applications, locate unit at least 6 in. above roof surface. Place unit above a load-bearing wall and isolate unit and tubing set from structure.

Arrange supporting members to adequately support unit and minimize transmission of vibration to building. Consult local codes governing rooftop applications.

The minimum outdoor operating ambient in cooling mode is 55°F (12.8°C), and the maximum outdoor operating ambient in cooling mode is 125°F (51.6°C). The maximum outdoor operating ambient in heating mode is 66°F (18.8°C).

PROCEDURE 3—ELEVATE UNIT

⚠ CAUTION: Accumulation of water and ice in base pan may cause equipment damage.

In areas where prolonged freezing temperatures are encountered, elevate unit per local climate and code requirements to provide clearance above estimated snowfall level and ensure adequate drainage of unit.

PROCEDURE 4—REPLACE CHECK-FLO-RATER® PISTON (IF REQUIRED) OR TXV (REQUIRED ON PH12)

If unit is being installed with piston, check indoor coil piston to see if it matches required piston shown on unit rating plate. If it does not match, replace indoor coil piston with piston shipped with outdoor unit. The indoor piston shipped with outdoor unit is correct for any approved indoor coil combination.

NOTE: If a TXV is to be installed on indoor unit, remove indoor coil piston.

⚠ CAUTION: Do not install with evaporator coils having capillary tube metering devices.

Check outdoor unit piston as follows:

1. Remove cap and retainer holding outdoor piston in liquid service valve.
2. Remove outdoor piston and check size with matching number on unit rating plate.
3. After verifying size, reinstall piston and retainer. If O-ring is damaged during removal, install new retainer.

→ For PH12 Models:

After removing existing Check-Flo-Rater from indoor coil, install field-supplied bi-flow hard shutoff TXV kit.

For TXV kit part number and charging instructions, refer to TXV label on your unit. If indoor unit (fan coil) comes factory equipped with a bi-flow hard shutoff TXV, no TXV change is required.

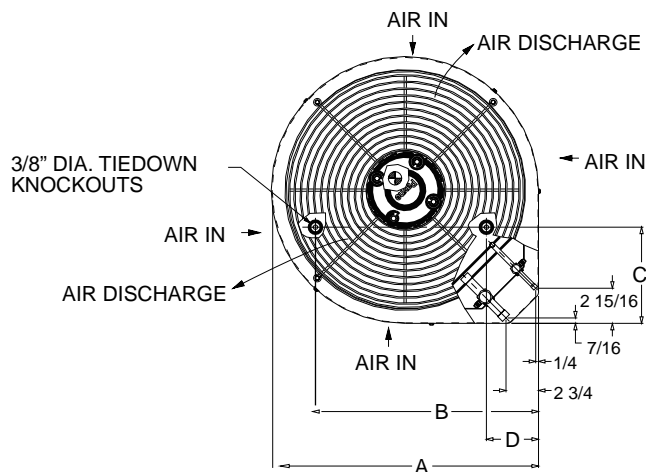

A01340

UNIT SIZE	A	B	C	D
PH10 018-030; PH12 018	22-1/2	18-1/2	8-3/16	4-1/16
PH10 036-060; PH12 024-060	30	23-1/2	10	6-1/2

Fig. 2—Unit Dimensions in Inches

Install TXV kit to indoor coil as follows:

1. Install suction tube adapter.
2. Install liquid flare-to-sweat adapter.
3. Connect external equalizer tube to fitting on suction tube adapter.
4. Position sensing bulb on horizontal portion of suction tube adapter. Secure using supplied hardware.
5. Insulate bulb after installation.
6. Leak check all connections.

PROCEDURE 5—MAKE PIPING CONNECTIONS

⚠ CAUTION: Relieve pressure and recover all refrigerant before system repair or final unit disposal to avoid personal injury or death. Use all service ports and open all flow-control devices, including solenoid valves.

⚠ CAUTION: If any refrigerant tubing is buried, provide a minimum 6-in. vertical rise to valve connections at unit. Refrigerant tubing lengths up to 36 in. may be buried without further consideration. For buried lines longer than 3 ft, consult your local distributor.

Outdoor units may be connected to indoor sections using accessory tubing package or field-supplied refrigerant grade tubing of correct size and condition. For tubing requirements beyond 50 ft, consult Residential Split-System Long-Line Application Guideline which is available at your local distributor. Refer to Table 1 for refrigerant tube dimensions and connections.

If refrigerant tubes or indoor coil is exposed to atmospheric conditions for longer than 5 minutes, it must be evacuated to 500 microns to eliminate contamination and moisture in system

A. Outdoor Units Connected to Factory-Approved Indoor

Outdoor unit contains correct system refrigerant charge for operation with indoor unit of same size when connected by 15 ft of field-supplied or factory accessory tubing. Check refrigerant charge for maximum efficiency. (See Procedure 9—Check Charge.)

B. Refrigerant Tubing

Connect tubing to fittings on outdoor unit vapor and liquid service valves.

C. Sweat Connection

⚠ CAUTION: To prevent damage to unit or service valves while brazing, use a brazing shield, and wrap service valves with wet cloth or use a heat sink material

Use refrigerant grade tubing. Service valves are closed from factory and ready for brazing. Remove plastic retainer holding outdoor piston in liquid service valve and connect sweat/flare adapter provided to valve. (See Fig. 3.) After wrapping the service valve with a wet cloth, braze sweat connections using industry accepted methods and materials. Consult local code requirements. Refrigerant tubing and indoor coil are now ready for leak testing. This check should include all field and factory joints.

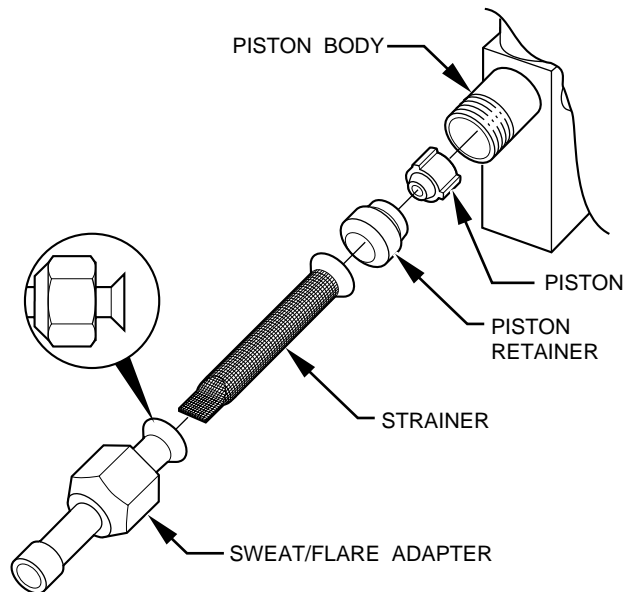

A97512

Fig. 3—Service Valve with Sweat Adapter Tube

PROCEDURE 6—MAKE ELECTRICAL CONNECTIONS

⚠ WARNING: To avoid personal injury or death, do not supply power to unit with compressor terminal box cover removed.

Be sure field wiring complies with local and national fire, safety, and electrical codes, and voltage to system is within limits shown on unit rating plate. Contact local power company for correction of improper voltage. See unit rating plate for recommended circuit protection device.

NOTE: Operation of unit on improper line voltage constitutes abuse and could affect unit reliability. See unit rating plate. Do not install unit in system where voltage or phase imbalance (3 phase) may fluctuate above or below permissible limits.

NOTE: Use copper wire only between disconnect switch and unit.

NOTE: Install branch circuit disconnect per NEC of adequate size to handle unit starting current. Locate disconnect within sight from and readily accessible from unit, per Section 440-14 of NEC.

A. Route Ground and Power Wires

Remove access panel to gain access to unit wiring. Extend wires from disconnect through power wiring hole provided and into unit control box.

⚠ WARNING: The cabinet must have an uninterrupted or unbroken ground to minimize personal injury if an electrical fault should occur. The ground may consist of electrical wire or metal conduit when installed in accordance with existing electrical codes. Failure to follow this warning could result in an electrical shock, fire, or death.

B. Connect Ground and Power Wires

Connect ground wire to ground connection in control box for safety. Connect power wiring to contactor as shown in Fig. 4.

C. Connect Control Wiring

Route 24v control wires through control wiring grommet and connect leads to control wiring. (See Fig. 6 and 7.)

Use No. 18 AWG color-coded, insulated (95°F/35°C minimum) wires. If thermostat is located more than 100 ft from unit (as measured along control voltage wires), use No. 16 AWG color-coded wires to avoid excessive voltage drop.

Use furnace- or fan-coil transformer as 24v (40va minimum) supply for system or use accessory transformer.

NOTE: Use of available 24v accessories may exceed the minimum 40va power requirement. Determine total transformer loading and increase the transformer capacity or split the load with an accessory transformer as required.

NOTE: The defrost timer is factory set for 90-minute cycles. The timer can be field set for 30- and 50-minute cycles depending on defrost conditions in your geographical location.

PROCEDURE 7—INSTALL ELECTRICAL ACCESSORIES

Refer to individual instructions packaged with kits or accessories when installing.

PROCEDURE 8—START-UP

⚠ CAUTION: To prevent compressor damage or personal injury, DO NOT over charge system with refrigerant, operate unit in a vacuum or at negative pressure, or disable low pressure switch. Dome temperatures may be HOT in scroll compressor units!

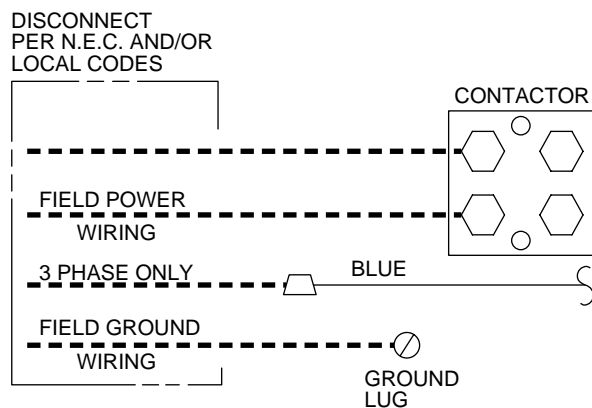

A94025

Fig. 4—Line Power Connections

1. If equipped with a crankcase heater, energize a minimum of 24 hr before starting unit. To energize heater only, set thermostat to OFF mode and close electrical disconnect to outdoor unit.

A crankcase heater and liquid-line solenoid are required if refrigerant tubing is longer than 50 ft.

⚠ CAUTION: To prevent personal injury wear safety glasses, protective clothing, and gloves when handling refrigerant. Front seating service valves are equipped with Schrader valves.

2. Fully open liquid and vapor service valves.
3. Unit is shipped with valve stem(s) front seated, and caps installed. Replace stem caps after system is opened to refrigerant flow. Replace caps finger-tight and tighten additional 1/6 turn with wrench for front seating valves (female hex stem).
4. Close electrical disconnects to energize system.
5. Set room thermostat at desired temperature.
6. Set room thermostat at HEAT or COOL and fan to ON or AUTO mode, as desired. Operate unit for 15 minutes. Check system refrigerant charge. (See Procedure 9.)
7. Factory charge is shown on outdoor rating plate. Adjust charge in cooling mode by following procedure shown on charging table. Check charge in heating mode by following procedure shown on heating check charge. Both are located on outdoor unit

⚠ CAUTION: Do not vent refrigerant into atmosphere. Relieve pressure and recover all refrigerant before system repair or final unit disposal to avoid personal injury or death. Use all service ports and open all flow-control devices, including solenoid valve

-
- ⚠ CAUTION:**
- 3-phase scroll compressors are rotation sensitive.
 - A flashing LED on phase monitor indicates reverse rotation. (See Fig. 5 and Table 2.)
 - This will not allow contactor to be energized.
 - Disconnect power to unit and interchange 2 field wiring leads on unit contactor.
-

A. SEQUENCE OF OPERATION

With power supplied to indoor and outdoor units, transformer is energized.

COOLING

On a call for cooling, thermostat makes circuits R-O, R-Y, and R-G. Circuit R-O energizes reversing valve, switching it to cooling position. On three phase models with scroll compressors, the units are equipped with a phase monitor to detect if the incoming power is correctly phased for compressor operation. (See Fig. 18 and Table 3.) If the phasing is correct, circuit R-Y energizes contactor, starting outdoor fan motor and compressor circuit. R-G energizes indoor unit blower relay, starting indoor blower motor on high speed.

NOTE: If the phasing is incorrect, the contactor will not be energized. To correct the phasing interchange any two of the three power connections on the field side.

When thermostat is satisfied, contacts open, de-energizing the contactor and blower relay. Compressor and motors should stop.

NOTE: If indoor unit is equipped with a time-delay relay circuit, the blower runs an additional 90 sec to increase system efficiency.

HEATING

On a call for heating, thermostat makes circuits R-Y and R-G. If phasing is correct, circuit R-Y energizes contactor, starting outdoor fan motor and compressor. Circuit R-G energizes indoor blower relay, starting blower motor on high speed.

Should temperature continue to fall, R-W2 is made through second-stage room thermostat. Circuit R-W2 energizes a relay, bringing on first bank of supplemental electric heat. If outdoor temperature falls below setting of outdoor thermostat (field-installed option), contacts close to complete circuit and bring on second bank of supplemental electric heat.

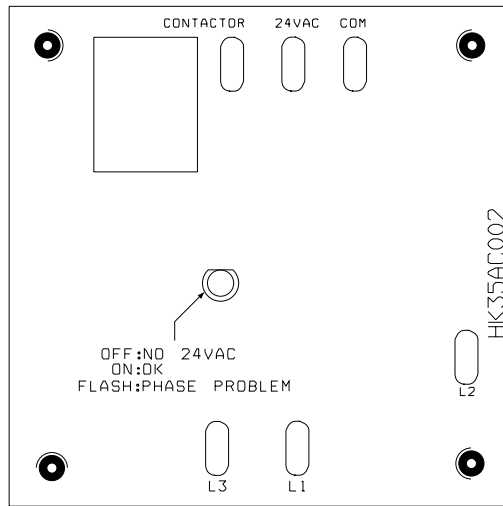

A00010

Fig. 5—Phase Monitor Control

Table 2—Phase Monitor LED Indicators

LED	STATUS
OFF	No call for compressor operation
FLASHING	Reversed phase
ON	Normal

When thermostat is satisfied, its contacts open, de-energizing contactor and relay. All heaters and motors should stop.

DEFROST

The defrost control is a time/temperature control which includes a field-selectable (quick-connects located at board edge) time period between defrost cycles (30, 50, and 90 minutes), factory set at 90 minutes.

The electronic timer and defrost cycle will start only when contactor is energized and defrost thermostat is closed.

The defrost mode is identical to cooling mode except that outdoor fan motor stops and a second-stage heat is turned on to continue warming conditioned space.

PROCEDURE 9—CHECK CHARGE

Factory charge is shown on unit rating plate.

⚠ CAUTION: Compressor damage may occur if system is overcharged.

Adjust charge in cooling mode by following procedure shown on superheat charging tables. Check charge in heating mode by following procedure shown on heating check chart, both located on unit.

⚠ CAUTION: Do not vent refrigerant to atmosphere. Recover during system repair or final unit disposal.

PROCEDURE 10—CARE AND MAINTENANCE

For continuing high performance, and to minimize possible equipment failure, it is essential that periodic maintenance be performed on this equipment. Consult your servicing contractor or Users Manual for proper frequency of maintenance. Frequency of maintenance may vary depending upon geographic areas, such as coastal applications.

PROCEDURE 11—LEAVE USER'S MANUAL WITH HOMEOWNER

Explain system operation and maintenance procedures outlined in User's Manual.

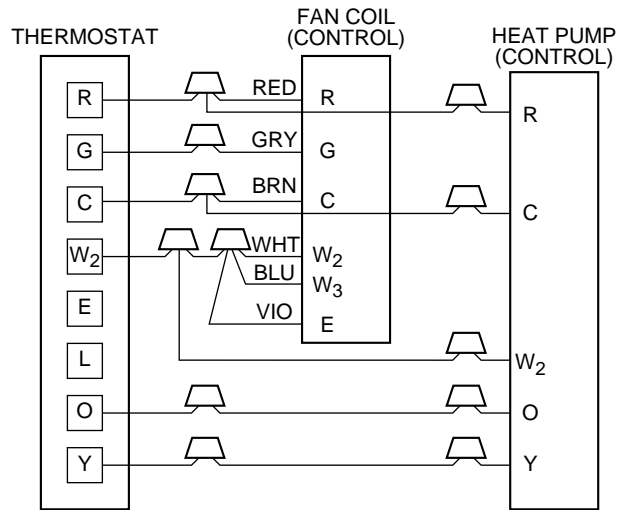

A94060

Fig. 6—Wiring Layout PFMNA018 through A070

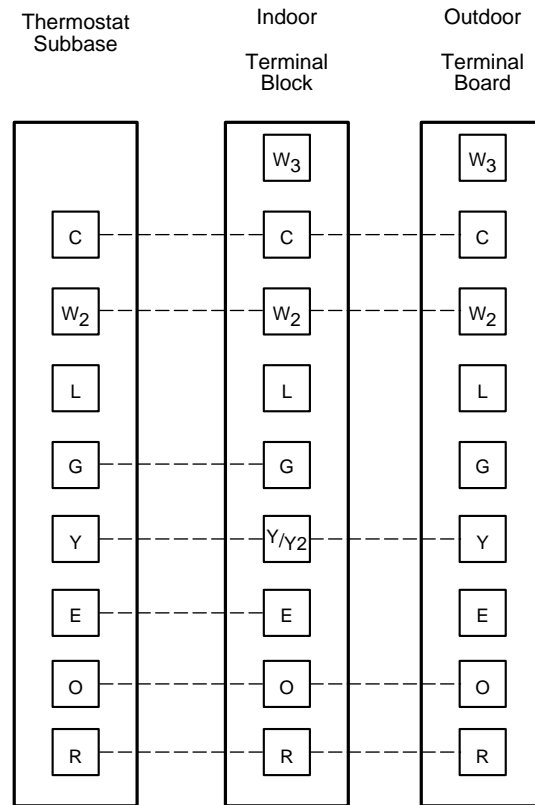

A93102

Fig. 7—Wiring Layout PF1MNA071

