

AUTOMATION PRODUCTS GROUP, INC.

Operator's Manual

FLR Series

Magnetic Float Sensors

9003284
Rev. A6, 07/15



Automation Products Group, Inc.

Tel: 1/888/525-7300 • Fax: 1/435/753-7490 • www.apgsensors.com • E-mail: sales@apgsensors.com

Table of Contents

Warranty 3
Description..... 4
Installation.....5-6
Wiring 7
Circuit Protection 8
Field Adjustment of Actuation Point.....9-21
Inspection & Maintenance 22
Technical Notes 22
Specifications..... 23
Certificate of Compliance..... 24-27

• **Warranty and Warranty Restrictions**

APG warrants its products to be free from defects of material and workmanship and will, without charge, replace or repair any equipment found defective upon inspection at its factory, provided the equipment has been returned, transportation prepaid, within 24 months from date of shipment from factory.

THE FOREGOING WARRANTY IS IN LIEU OF AND EXCLUDES ALL OTHER WARRANTIES NOT EXPRESSLY SET FORTH HEREIN, WHETHER EXPRESSED OR IMPLIED BY OPERATION OF LAW OR OTHERWISE INCLUDING BUT NOT LIMITED TO ANY IMPLIED WARRANTIES OF MERCHANTABILITY OR FITNESS FOR A PARTICULAR PURPOSE.

No representation or warranty, express or implied, made by any sales representative, distributor, or other agent or representative of APG which is not specifically set forth herein shall be binding upon APG. APG shall not be liable for any incidental or consequential damages, losses or expenses directly or indirectly arising from the sale, handling, improper application or use of the goods or from any other cause relating thereto and APG's liability hereunder, in any case, is expressly limited to the repair or replacement (at APG's option) of goods.

Warranty is specifically at the factory. Any on site service will be provided at the sole expense of the Purchaser at standard field service rates.

All associated equipment must be protected by properly rated electronic/electrical protection devices. APG shall not be liable for any damage due to improper engineering or installation by the Purchaser or third parties. Proper installation, operation and maintenance of the product becomes the responsibility of the user upon receipt of the product.

Returns and allowances must be authorized by APG in advance. APG will assign a Return Material Authorization (RMA) number which must appear on all related papers and the outside of the shipping carton. All returns are subject to the final review by APG. Returns are subject to restocking charges as determined by APG's "Credit Return Policy".

• Description

The FLR series instruments contain reed switches in the stem and permanent magnets in the floats. As the float rises or falls with the level of the liquid, the magnet inside the float act on the reed switch inside the stem to provide the SPST switching action.

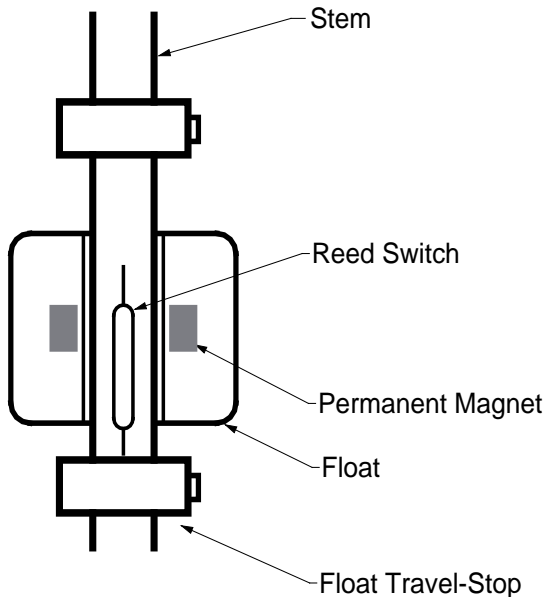

• Installation

- Unpacking -

When unpacking the instrument, exercise care not to subject the instrument to mechanical shock. After unpacking, visually inspect the instrument for damage.

- Environment -

The FLR series sensors should be installed in an areas indoor or outdoor which meets the following conditions:

1. Non-hazardous area.
2. The medium temperature does not exceed -40°F to 185°F (-14°C to 85°C).

NOTE: It is recommended that a sun shield be installed over the housing if exposed to direct sunlight.

3. Relative humidity up to 100%
4. Pollution Degree 2
5. Measurement Category II
6. Altitude 2000 m or less.
7. Locate the sensor away from strong magnetic fields such as those produced by motors, transformers, solenoid valves, etc.
8. The medium is free from metallic substances and other foreign matter.
9. No corrosive gases such as NH₃, SO₂, Cl₂, etc.
10. No excessive vibration
11. Ample space for maintenance and inspection.

• Installation

- Location -

Do not locate the FLR series sensor near inlets/outlets.

If there is surface wave action, then use a time-delay relay or stilling tube. If a stilling tube is used, drill vent holes in the tube and use a spacer to assure the float has free travel inside the tube.

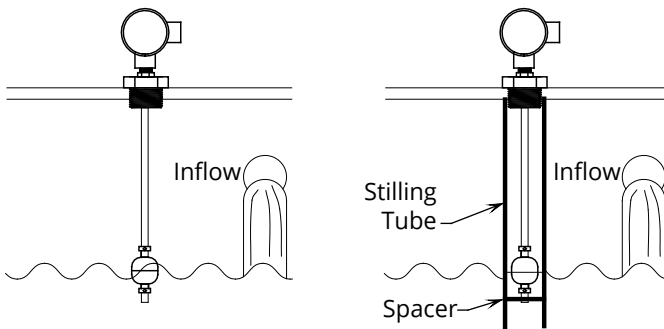

Wave action may cause switch to chatter.

Use a stilling tube or time-delay relay to prevent switch chatter.

- Mounting -

The FLR can be mounted up to 30° from vertical.

1. Flange Mounting

Provide the compatible mating flange on the tank and install using a suitable gasket.

2. Plug Mounting

Provide the compatible female boss on the tank and install the FLR with a suitable gasket, O-ring, or thread tape.

• **Wiring**

- Wiring for 1 to 4 switches

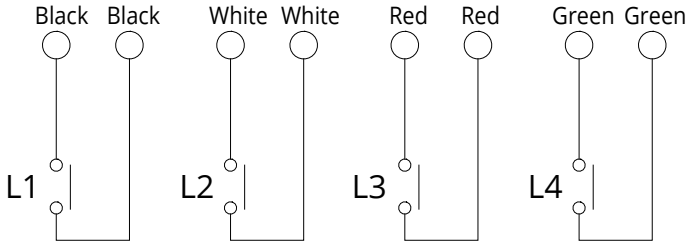

- Wiring for greater than 4 switches

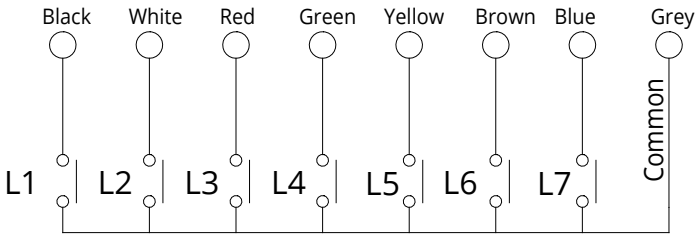

No. of Levels	Wiring Color							
	L1	L2	L3	L4	L5	L6	L7	Com.
L1	Blk x 2							
L2	Blk x 2	Wh x 2						
L3	Blk x 2	Wh x 2	Red x 2					
L4	Blk x 2	Wh x 2	Red x 2	Grn x 2				
L5	Black	White	Red	Green	Yellow			Grey
L6	Black	White	Red	Green	Yellow	Brown		Grey
L7	Black	White	Red	Green	Yellow	Brown	Blue	Grey

• **Circuit Protection**

WARNING!

DO NOT EXCEED CONTACT RATINGS! When an inductive load is used (e.g. a motor, a coil, or an electromagnetic relay), a back electromotive force of several hundred volts (energy stored in the inductance) arises when the contacts are opened. This results in considerable decrease in contact life. The same result arises even when a resistive load is used with a high voltage or a large current. The figures below show circuits for protecting the reed switch(s) from the back electromotive force.

Protecting Circuit Using Diode

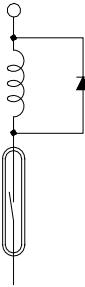

Protecting Circuit Using Varistor

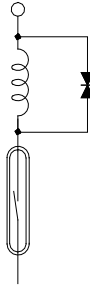

Protecting Circuit Using CR

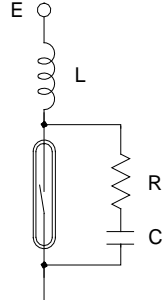

$$C = I/10 \text{ (}\mu\text{F)}$$

$$R = \text{Approx. } \frac{E}{10 \times I (1 + 50/E)}$$

Code A & B Switches

Max. contact capacity
Max. switching current

70 VA AC,
220 VAC 0.5 A, 120 VDC 0.5 A

Code C Switches

Max. contact capacity
Max. switching current

110 VA AC,
220 VAC 0.5 A, 115 VDC 0.5 A

• Field Adjustment Of Actuation Point(s)

The FLR sensors are designed to allow field adjustments of the actuation points by moving the floats and reed switches. This section contains two procedures for making field adjustments.

NOTE: FLR units without housings are hermetically sealed and cannot be field adjusted.

Procedure one should be used under the following conditions:

- a. You want to move the actuation point relative to the factory settings.
- b. There will be **no** change to the switching logic (normally open/normally closed).

Procedure two should be used under the following conditions:

- a. The float stops have been loosened and moved without marking their previous stem location.
- b. The switching logic needs to be reversed (normally open/normally closed).
- c. You want to move the actuation point independent of the factory settings.

Procedure One:



1. Before making any adjustments to the FLR, mark the stem location of the float stops that will need to be moved.

2. Determine the location of the new actuation point. The actuation point is located at the center point between the float stops.

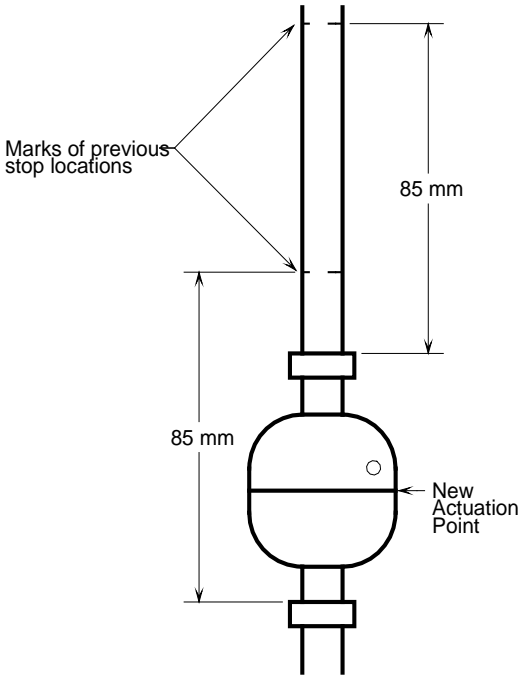

3. Loosen the retaining hex screws on the float stops and slide the stops exactly the same distance along the stem to their new locations. Re-secure the stops to the stem.

For example (refer to drawing above): Suppose the actuation point needs to be adjusted 85 mm lower on the stem. The first step is to mark the location of both float stops that will need to be moved. Next, move the float stops (and float) exactly 85 mm down the stem from your marks. Re-secure the stops to the stem and continue to step 4.

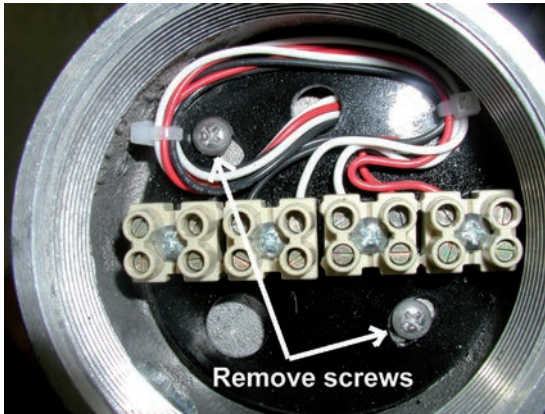

4. Once the stops and float are set in the desired location, the reed switch assembly inside the stem needs to be adjusted to match the new actuation point. To access the reed assembly, you will need to remove the two screws that secure the terminal mounting plate to the housing.



5. Carefully remove the terminal mounting plate along with the wiring and internal reed switch assembly from the stem of the FLR. Keep the assembly straight and take care not to bend or put stress on the reed switches.

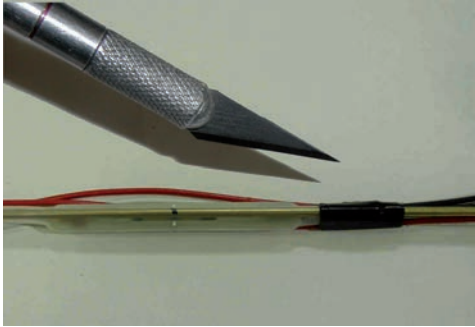

6. Carefully lay the reed switch assembly on a clean surface and remove the tape securing the wires to the assembly rod. Do not cut into the wires!

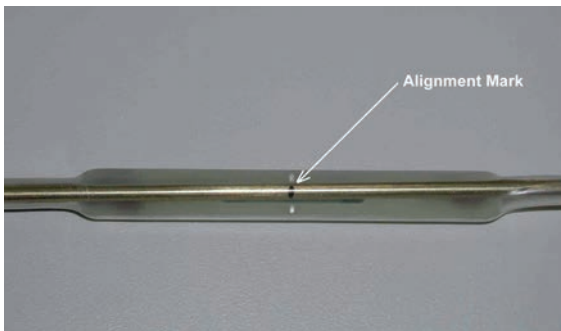

7. Looking closely at the reed switch assembly rod, locate a black mark at each reed switch location. During factory calibration, these marks are used to align the center of each reed switch with the desired actuation point. To align the reed switch with the newly adjusted float position, simply move the reed switch along the rod the same distance that you previously moved the float stops on the stem. This distance is measured from the center of the reed switch to the black mark on the rod.

8. Having moved the reed switches into the correct position, use electrical tape to re-secure the wires to the assembly rod. Carefully reassemble the FLR and test the new actuation point.

• Field Adjustment Of Actuation Point(s)

Procedure Two:

1. Determine the desired actuation point.
2. Loosen the retaining screws on float stops that need to be repositioned.
3. Slide the float along the stem until the float's center is aligned with the desired actuation point.
4. Re-secure the float stops 9 mm above and below the new float position (refer to drawing below).

NOTE: The 9 mm distance between the float and stops is critical for the switch to operate reliably.

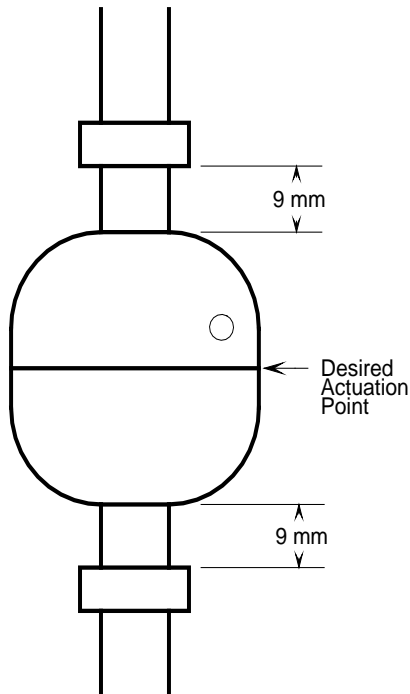

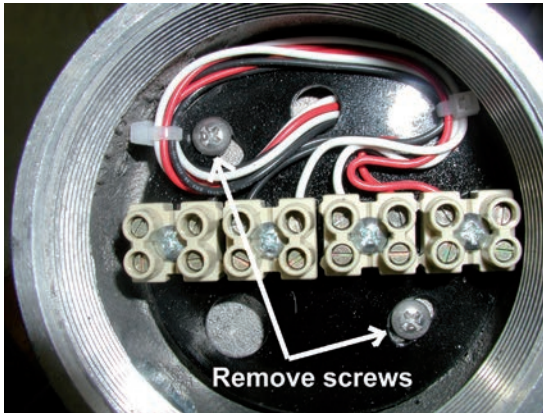

5. With the float and stops in place at the new actuation point, the internal reed switch needs to be repositioned to match the new actuation point. Remove the two screws that secure the terminal mounting plate to the housing (shown above).



6. Carefully remove the terminal mounting plate along with the wiring and internal reed switch assembly from the stem of the FLR. Keep the assembly straight and take care not to bend or put stress on the reed switches.

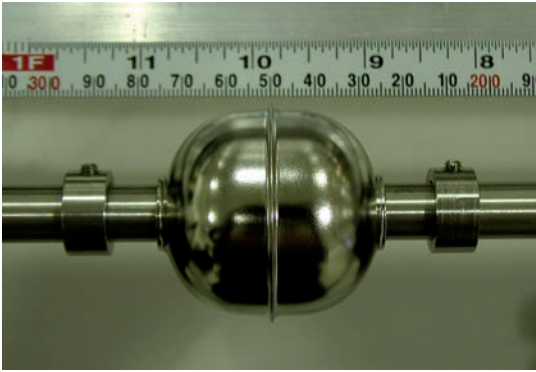

7. Measure the distance from the bottom of the stem to the new actuation point. The actuation point is at the center position between the float stops. In the example above, the actuation point is at 250 mm.

8. A brass rod inside the stem holds the reed switches in place. The location of the switch needs to be adjusted to match the new actuation point. Determine which switch type you are using and continue to the step indicated below.

CODE "A & B" (approx. 20 mm switch length)

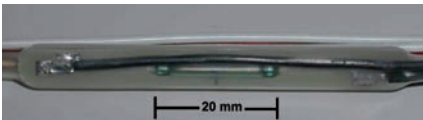

Normally Open

continue to step **8a** (page 16)

Normally Closed

skip to step **8b** (page 17)

CODE "C" (approx. 30 mm switch length)

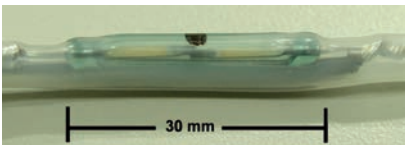

Normally Open

skip to step **8c** (page 18)

Normally Closed

skip to step **8d** (page 19)

NOTE: The float is considered in the "normal" position when it is at rest against the lower stop.

Normally Open Switching for Code "A" & "B" Switches

8a. For "normally open" (NO) switching (code A & B switches), subtract 6 mm from the measurement taken in step 7 and record the result. This distance will be used to adjust the reed switch along the internal brass rod. The 6 mm is subtracted to compensate for the plug in the bottom of the stem. Refer to drawings below.

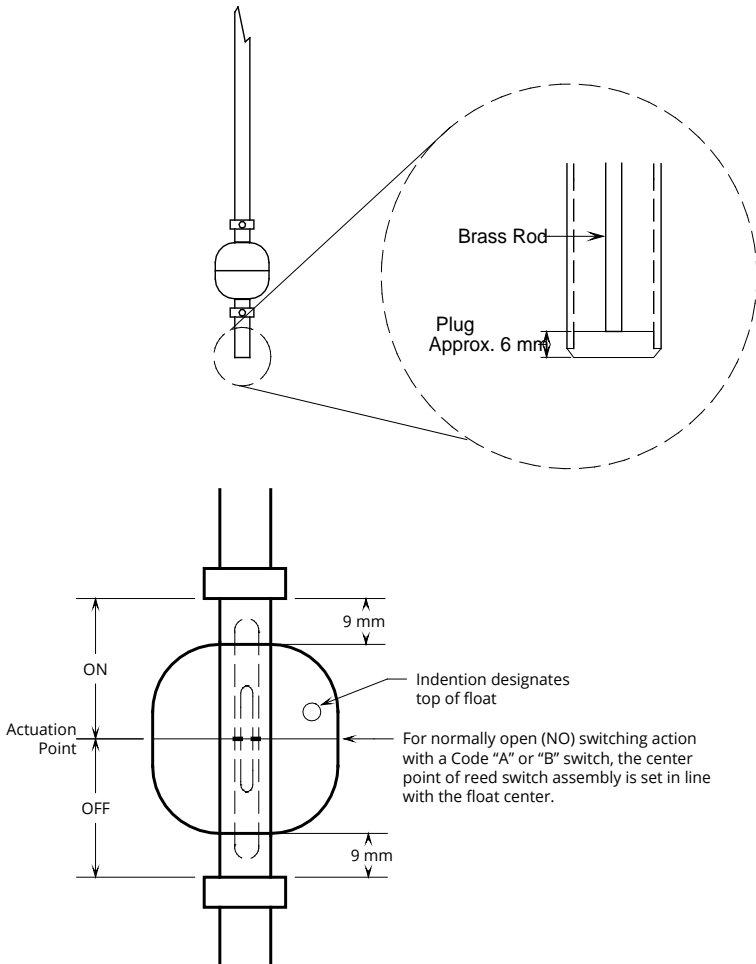

Normally Closed Switching for Code "A" & "B" Switches

8b. For "normally closed" (NC) switching (code A & B switches), subtract 18 mm from the measurement taken in step 7 and record the result. This distance will be used to adjust the reed switch along the internal brass rod. The 18 mm is subtracted to compensate for both the offset of the reed switch from the actuation point (-12 mm), and the plug in the bottom of the stem (-6 mm). Refer to drawings below.

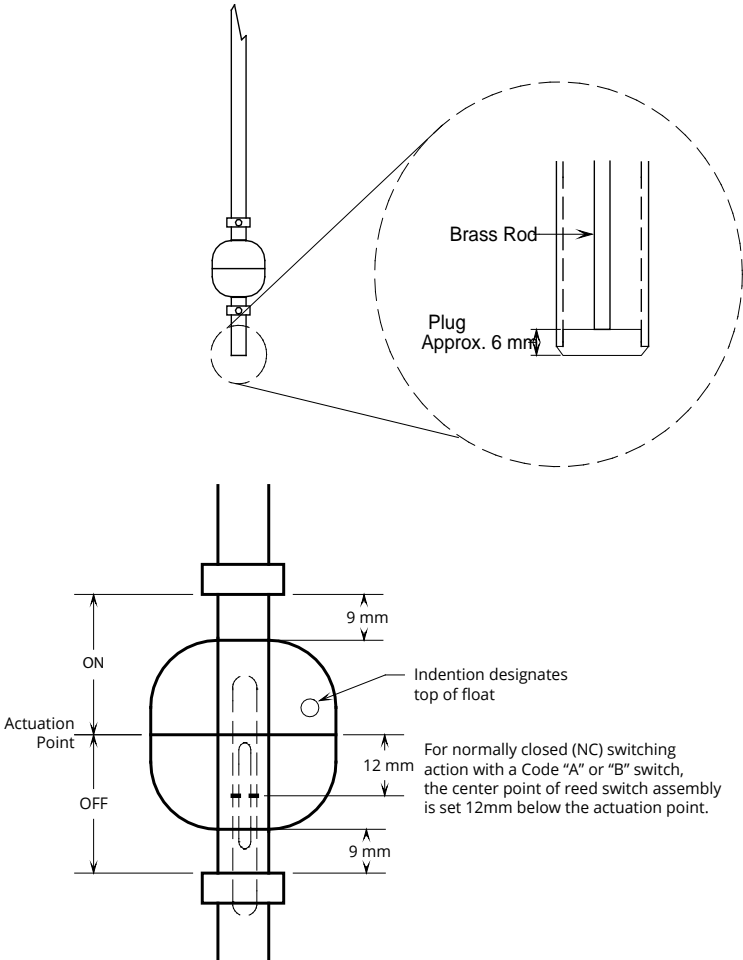

Normally Open Switching for Code "C" Switches

8c. For "normally open" (NO) switching (code C switches), subtract 3 mm from the measurement taken in step 7 and record the result. This distance will be used to adjust the reed switch along the internal brass rod. The 3 mm is subtracted to compensate for both the offset of the reed switch from the actuation point (+3 mm), and the plug in the bottom of the stem (-6 mm). Refer to drawings below.

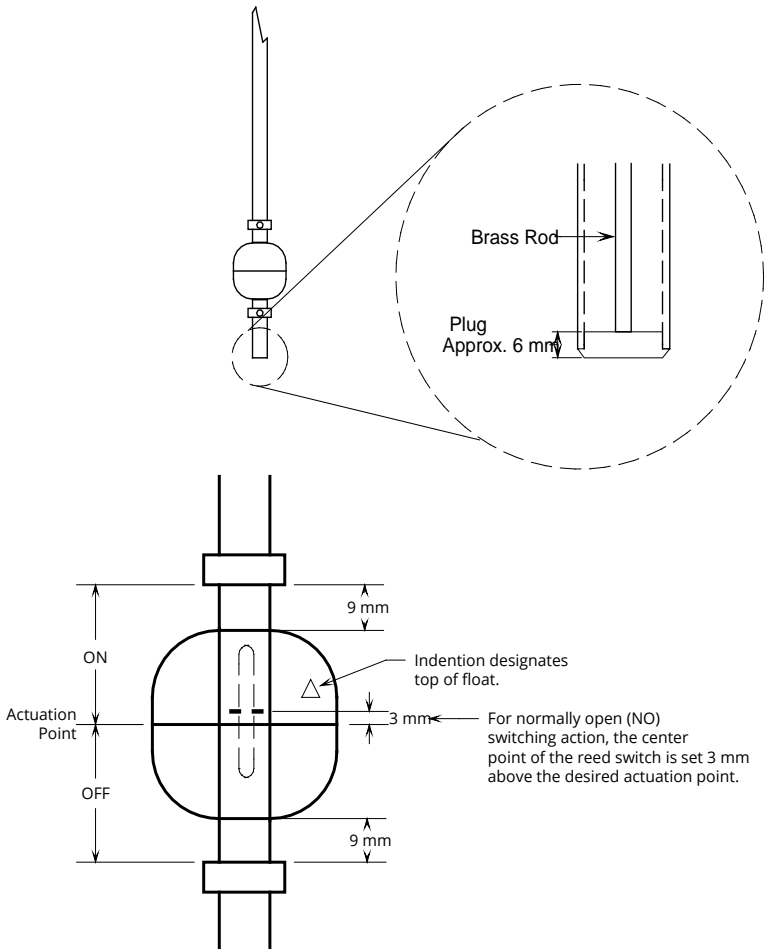

Normally Closed Switching for Code "C" Switches

8d. For "normally closed" (NC) switching (code C switches), subtract 12 mm from the measurement taken in step 7 and record the result. This distance will be used to adjust the reed switch along the internal brass rod. The 12 mm is subtracted to compensate for both the offset of the reed switch from the actuation point (-6 mm), and the plug in the bottom of the stem (-6 mm). Refer to drawings below.

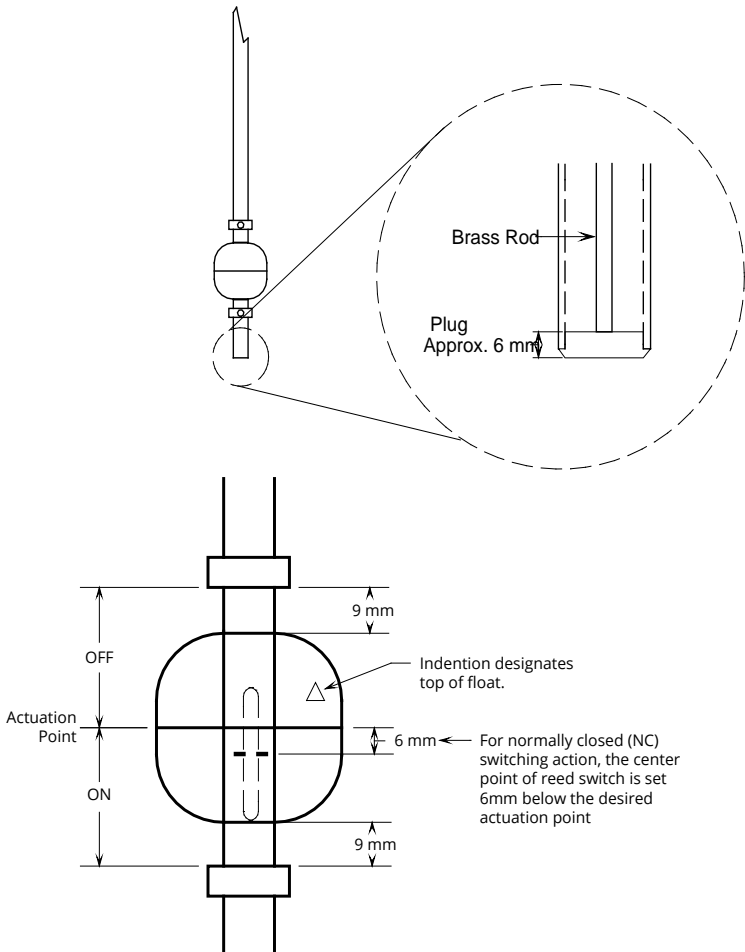

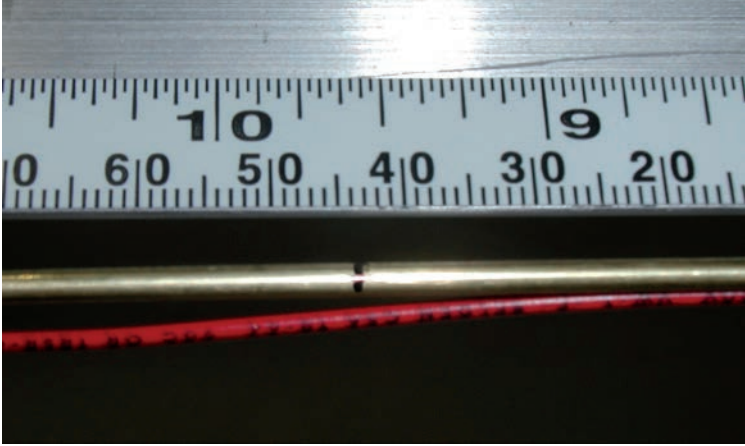

9. Using the distance you derived in step 8, measure from the bottom of the reed switch assembly and mark the center rod at that location.

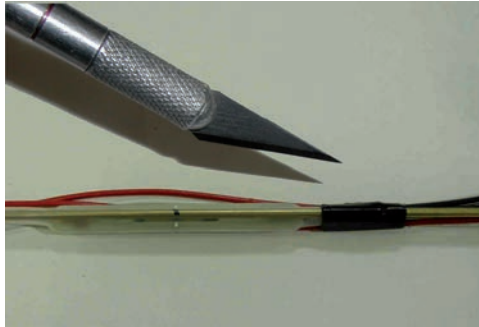

10. Remove the tape securing the reed switch to the assembly rod. Be careful not to cut any of the wires or to put pressure in the reed switch.

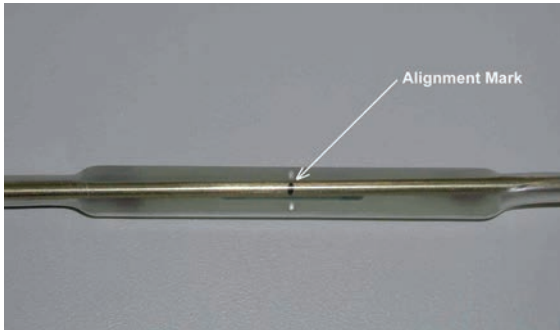

11. Slide the reed switch along the rod until the center lines up with the mark you make on the rod in step 9. Re-secure the wires to the center rod with electrical tape.
12. Carefully reinsert the reed switch assembly into the stem and test the switch action.
13. If the actuation point needs fine tuning, remove the reed assembly from the stem and make any necessary adjustments to the reed switch position.
14. Reassemble the unit.

• Inspection and Maintenance

Periodic inspection is necessary to keep your FLR unit in good working order.

CAUTION! Do not remove the housing cover until the power supplied to the unit is turned off.

1. Keep the sensor clean.

Never leave the housing cover off. If the cover becomes damaged or is misplaced, order a replacement immediately.

If sediment or other foreign matter is trapped between the stem and the float, detection errors may be caused. Keep the float and stem clean.

2. Inspect the switches and terminals.

• Technical Notes

1. The float travel stop settings are based on how the magnetic field influences the reed switch. Normally it is not necessary to move the stop. If the stops are moved, check the switch action for float overrun.

2. Normally Open (NO) (switch closes as level rises) and Normally Closed (NC) (switch closes as level falls).

• FLR Specifications

Maximum Number Switching Points	7
Resolution	+/- 1/16" (2mm)
Field Adjustable Actuation Levels	Yes
Maximum Length	153 in.
Maximum Process Temperature	-40 ⁰ to 185 ⁰ F
Housing Material	Die Cast Aluminium
Hazardous Rating	None
Housing Rating	NEMA 4
Contact Rating:	
Code A & B Switch	
Max. contact capacity	70 VA AC,
Max. switching current	200 VAC 0.5 A, 120 VDC 0.5 A
Code C Switch	
Max. contact capacity	110 VA AC,
Max. switching current	220 VAC 0.5 A, 115 VDC 0.5 A



Certificate of Compliance

Certificate: 2167400 **Master Contract:** 237484
Project: 2167400 **Date Issued:** 2009/11/16
Issued to: Automation Products Group Inc
 1025 West 1700 North
 Logan, UT 84321
 USA
 Attention: Karl Reid

The products listed below are eligible to bear the CSA Mark shown with adjacent indicators 'C' and 'US' for Canada and US or with adjacent indicator 'US' for US only or without either indicator for Canada only.



Issued by: Frank Gessner

Authorized by: Patricia Pasemko, Operations Manager

PRODUCTS

CLASS 2252 05 - PROCESS CONTROL EQUIPMENT
CLASS 2252 85 - PROCESS CONTROL EQUIPMENT - Certified to US Standards

- Float Level Sensors, permanently connected, indoor and outdoor use, max. operating ambient 85°C:
- Models FLXx and FLRx, rated 220 V, 0.5 A;
 - Models RPMx, RPXx and RPEx, rated 5 - 15 Vdc, 100 mA, or 12 to 24 Vdc, 4-20mA;
 - Model RPAX, rated 12 to 24 Vdc, 4-20mA;
 - Model CTR-0100 (P/Ns 110101 and 110101-0001), Loop Powered 4-20mA Module, rated 4-20mA output is 12 to 24 Vdc.

Note: The above models are Pollution Degree 2, Measurement Category II.

Notes for Models FLXx, FLRx, RPMx, RPAX, RPXx, RPEx:

DQD 507 Rev. 2009-09-01



Certificate: 2167400

Master Contract: 237484

Project: 2167400

Date Issued: 2009/11/16

1. The "x" in the Model designations may be any alpha-numeric character, to denote minor mechanical options, not affecting safety. Refer to Illustration 28 for Model designator and suffix details.
2. The equipment is intended to be installed as required by the applicable electrical code (CEC, NEC) and as specified by the manufacturer's Installation Instructions.
3. The circuit board P/N STF-CTR-01** from the Model RPMx Probe may be supplied as a component part where the suitability of the final installation will be inspected by the authority with jurisdiction in the area where installed.
4. The installation will be inspected by the authority with jurisdiction in the area where installed.

CLASS 2258 02 - PROCESS CONTROL EQUIPMENT - FOR HAZARDOUS LOCATIONS

CLASS 2258 82 - PROCESS CONTROL EQUIPMENT - FOR HAZARDOUS LOCATIONS, U.S. Requirements

Class I, Division 1, Groups C, and D

- Float Level Sensors, model FLXx, rated 220 V, 0.5 A, max., and model RPMx and RPXx, rated 5 - 15 Vdc, 100mA or 12 to 24 Vdc, 4-20mA; operating ambient 40°C.

Notes for Models FLXx, RPMx, RPXx:

1. The "x" in the Model designations may be any alpha-numeric character, to denote minor mechanical options, not affecting safety.
2. The equipment is intended to be installed as required by the applicable electrical code (CEC, NEC) and as specified by the manufacturers Installation Instructions.
3. The installation will be inspected by the authority with jurisdiction in the area where installed.

Class I, Division 2, Groups C, and D

- Float Level Sensor model FLXx, rated 220 V, 0.5 A, model RPMx and RPXx, rated 5 - 15 Vdc, 100mA, or rated 12 to 24 Vdc, 4-20mA, and model RPAX, rated 12 to 24 Vdc, 4-20mA; max; operating ambient 85°C.

Notes for Models FLXx, RPMx, RPAX, RPXx:

1. The "x" in the Model designations may be any alpha-numeric character, to denote minor mechanical options, not affecting safety.
2. The equipment is intended to be installed as required by the applicable electrical code (CEC, NEC) and as specified by the manufacturers Installation Instructions.
3. The installation will be inspected by the authority with jurisdiction in the area where installed.

DQD 507 Rev. 2009-09-01



Certificate: 2167400

Master Contract: 237484

Project: 2167400

Date Issued: 2009/11/16

CLASS 2258 03 - PROCESS CONTROL EQUIPMENT - INTRINSICALLY SAFE AND NON INCENDIVE SYSTEMS - FOR HAZARDOUS LOCATIONS

CLASS 2258 83 - PROCESS CONTROL EQUIPMENT - INTRINSICALLY SAFE AND NON INCENDIVE SYSTEMS - FOR HAZARDOUS LOCATIONS, CERTIFIED TO U.S. STANDARDS

Class I, Division 2, Groups C, and D

- Float Level Sensor model RPMx and RPXx, rated 5 - 15 Vdc, 100mA, or rated 12 to 24 Vdc, 4-20mA, and model RPAX, rated 12 to 24 Vdc, 4-20mA; max; operating ambient 85°C. Field wiring is non-incendive when installed per drawings 9001415, 9001932 and 9002023 respectively.

Notes for Models RPMx, RPAX, RPXx:

1. The "x" in the Model designations may be any alpha-numeric character, to denote minor mechanical options, not affecting safety.
2. The equipment is intended to be installed as required by the applicable electrical code (CEC, NEC) and as specified by the manufacturers Installation Instructions.
3. The installation will be inspected by the authority with jurisdiction in the area where installed.

CLASS 2258 04 - PROCESS CONTROL EQUIPMENT - INTRINSICALLY SAFE, ENTITY - FOR HAZARDOUS LOCATIONS

CLASS 2258 84 - PROCESS CONTROL EQUIPMENT - INTRINSICALLY SAFE, ENTITY - FOR HAZARDOUS LOCATIONS, U.S. Requirements

Class I, Division 1, Groups C, and D

- Float Level Sensors, model RPMx, RPAX, RPXx and model CTRx loop powered 24Vdc, 4-20mA converter module, max. operating ambient 85°C; Temperature Code rating T3C; Intrinsically Safe when connected as per drawing 9001414, 9001423 and 9001930 with the following Entity Parameters: $V_{max} = 30V$, $I_{max} = 130mA$, $C_i = 3nF$, $L_i = 0uH$.

Notes for Models RPMx, RPAX and RPXx:

1. The "x" in the Model designations may be any alpha-numeric character, to denote minor mechanical options, not affecting safety.
2. The equipment is intended to be installed as required by the applicable electrical code (CEC, NEC) and as specified by the manufacturers Installation Instructions.
3. The installation will be inspected by the authority with jurisdiction in the area where installed.

APPLICABLE REQUIREMENTS

CSA Standards C22.2 No. 0-M91 - General Requirements - Canadian Electrical Code, Part II

DQD 507 Rev. 2009-09-01



Certificate: 2167400

Master Contract: 237484

Project: 2167400

Date Issued: 2009/11/16

CSA Standards C22.2 No. 30-M1987 - Explosion-Proof Enclosures for Use in Class I Hazardous Locations

CAN/CSA C22.2 No. 61010-1-04 - Safety Requirements for Electrical Equipment for Measurement, Control, and Laboratory Use, Part 1: General Requirements

CSA Standards C22.2 No. 157-M1992 - Intrinsically Safe and Non-Incendive Equipment for Use in Hazardous Locations

CSA Standards C22.2 No. 213-M1987 - Non-Incendive Electrical Equipment for Use in Class I, Division 2 Hazardous Locations

UL 61010-1 (2nd Edition) - Safety Requirements for Electrical Equipment for Measurement, Control, and Laboratory Use - Part 1: General Requirements

UL 913, Sixth Edition - Intrinsically Safe Apparatus and Associated Apparatus for use in Class I, II, III, Division 1, Hazardous (Classified) Locations

UL1203, Third Edition - Explosion-Proof and Dust-Ignition-Proof Electrical Equipment for Use in Hazardous (Classified) Locations

FM 3611, December 2004 - Nonincendive Electrical Equipment for Use in Class I and II, Divisions 1 and 2 Hazardous (Classified) Locations

TIL E-11 - Enclosures of Welded Construction for Class I, Division 1, Hazardous Locations appended to the applicable requirements

DQD 507 Rev. 2009-09-01

AUTOMATION PRODUCTS GROUP, INC.



Automation Products Group, Inc.

Tel: 1/888/525-7300

1/435/753-7300

Fax: 1/435/753-7490

e-mail: sales@apgsensors.com

www.apgsensors.com

Automation Products Group, Inc.

1025 W. 1700 N.

Logan, UT 84321