

Mistral3K

Aeolic Generator

User Manual



Table of Contents

Safety of Life	2
Safety of Installation	3
Safety of Machinery	4
Chapter 1 Wind Power System	5
1-1 Wind Turbine Specifications	5
1-2 Wind Turbine Description	7
1-3 Grid-tied Wind Power Inverter Specifications	8
1-4 Grid-tied Wind Power Inverter Description	9
1-5 Wind Power System Operation	9
Chapter 2 Installation of Wind Power System	11
2-1 Installation of Wind Turbine	11
2-2 Installation of Grid-tied Wind Power Inverter	15
2-3 Braking Box	18
Chapter 3 Wind Power System Operation	23
3-1 Start Test	23
3-2 Instruction of Grid-tied Wind Power Inverter	23
Chapter 4 Protection	25
4-1 Electromagnetic Brake Protection	25
4-2 High Wind Protection(Furl Protection)	25
Chapter 5 Troubleshooting	26
Chapter 6 Spare Parts List	27

Index of manual revision			
Revision	Date	Description	Executors
Rev_00	2009/01/03	First release	AS jc
Rev_01	2009/03/23	Release 1.02	AS cb jc
Rev_02	2009/04/01	Review wiring examples	AS jc



Please read this manual carefully and follow its instructions and recommendations, this manual will assist you to operate this renewable energy system safely and pleasantly.

Safety of Life

- 01.** Never touch any switch with wet hands.
- 02.** Always check and make sure there are no obstacles or people near the machine's movable parts before operating the machine.
- 03.** Cover your hair and do not wear loose clothing or jewelry to avoid becoming tangled or caught in the machine.
- 04.** Never touch or stand near the moving parts of the machine while the machine is operating. Serious injury may occur by being caught between the moving parts.
- 05.** Please avoid approaching the wind turbine. The high voltage of the turbine or inverter may cause casualty or electrical shock if touch, or you may get burn due to electrical short circuit.
- 06.** Always turn off the power before performing maintenance and inspection. Maintenance and inspection inside the cover is especially dangerous.
- 07.** Do not climb on the machine unless absolutely necessary.
- 08.** Machine and electricity of a renewable energy system contains certain dangers, it may cause death or injury while misuse the machine.
- 09.** Improper construction work may weaken the strength of tower or support frame structure, and result in casualty, death or losses of property.
- 10.** Lack of maintenance in any part of the system, improper operation of the wind energy power system and loose of components or parts may cause casualty, death or losses of property.
- 11.** Please avoiding approaching the blade due to high speed rotary blade due to the high possibility causing casualty or death, please shut off the system before performing maintenance.
- 12.** Do not lean on the machine while the machine is operating. Leaning on the covers can be very dangerous.
- 13.** If the turbine becomes loud or a loud sound is heard in tower, the system must be shut off immediately. A loud turbine or part will damage the turbine body soon enough, and it is possible to cause the tower to lean or to collapse and results in casualty.
- 14.** An untrained personnel or a person without adequate safety equipment is highly restricted to climb the tower. It is highly restricted to climb the tower before the blade of wind turbine stop as well.
- 15.** High voltage system (any contact point of the primary side of the system) indicates danger of shock and fatal harm. All the construction work and maintenance of high voltage system line must be performed and executed by professional personnel.
- 16.** To avoid danger, construction work and wiring must be done by professional personnel.



Important! Carlo GAVAZZI does not take any responsibility for any injury to persons or damage to things both due to mis handling of the turbine or bad electrical connection of the products.

Safety of Installation

- 01.** Leave space for maintenance. Install the machine so that the covers of the machine can be opened without interference.
- 02.** Make sure that the ground strong enough to support the machine.
- 03.** Only an authorized electrical technician should perform work with the power cable connections.
- 04.** Make sure that all bolts are tightened securely.
- 05.** Make sure that all related hoses are connected secure.
- 06.** The machine should be operated by one, well-trained person only. Injury can occur if more than one person operates the machine. If more than one operator is absolutely necessary, all involved operators must cooperate and be able to communicate.
- 07.** Never start machine operation without the safety devices in place.
- 08.** Construction work of tower or supporting frame must be done by professional installation personnel, electrical wire must be qualified product and wiring work be done by professional and qualified personnel. Construction work, wiring products and electrical installation personnel must be in accordance with construction regulation standard.
- 09.** Related permission certificates and engineering certificates are required for safe installation. Location of tower, tower and tower foundation must be professionally designed. Soil and wind field status must be put into consideration when selecting a location. Tower must keep far away from buildings, neighboring properties or electrical power lines. Do not attempt to climb the tower, only experienced personnel with adequate safety equipment is allowed to climb the tower. It is recommended that when installing tower, keep it away from buildings and electrical power lines for at least 100 meters (300ft).
- 10.** The construction and wiring process must be in accordance with electrical engineering regulations of the resident country.
- 11.** Never remove the covers unless absolutely necessary.
- 12.** These equipments must have proper heat elimination function, air current jam may bring fire disaster.

Safety of Machinery

- 01.** Never remove the inverter covers unless absolutely necessary, and after the device is turned off.
- 02.** Never put any tools or instruments on the machine operation panel or on any machine part.
- 03.** Be careful not to operate the wrong switch. Visually check the switches on the operation panel before operating them.
- 04.** Never change the parameter setting without consulting your local representative. If changed inadvertently, some parameters will cancel interlock setting.
- 05.** Wiring work for 200 VAC or higher voltage circuits must be performed only by an authorized electrical technician.
- 06.** Do not open the door of the electrical cabinet or the operation panel unless absolutely necessary. Opening the door allows dust, foreign matter, and moisture to enter the enclosure and can cause machine malfunctions.
- 07.** Carry out daily, monthly, and semi-annual inspection as specified in this operation manual.
- 08.** Clean the machine so that any abnormalities can be found easily.
- 09.** The output wiring of wind power system may cause a low voltage shock whenever the rotor is turning. Caution must be implemented at all times to avoid electrical shock.
- 10.** Please do not install wind power system near cliffs or precipices or on sharp hills such that the wind does not travel horizontally through the rotor.
- 11.** The weight distribution of the system is specially balanced. Any change of the system weight and balance, especially the tail, may cause malfunction of the Furl Protection Function.
- 12.** Additional Electromagnetic Brake Protection is provided by the electronic system controller, please refer to the electronic system controller manual for more details.

Chapter 1

Wind Power System

This system is the latest small wind power system designed to provide electricity which can be used on several different type applications, such as batteries charging, or stand alone remote electrical power supply system. Furthermore, with the additional Grid-tied Wind Power Inverter, the wind power system can also be connected to the power grid.

1-1 Wind Turbine Specifications

The wind turbine consists of a 2.6 meter rotor system and a generator which is 35cm in diameter. The 58 kilogram wind turbine is rated at 3000W @ 13.5m/s wind speed.

The wind turbine features superior low start-up wind speed blade design which provides great performance, very high system efficiency, and low noise. For tower installation procedures, please refer to the Chapter 2-1.

Wind Turbine Specifications			
Rotor diameter	2.6m/s	Total weight	58kg
Start-up wind Speed	2.5m/s	Furl Protection	Start @ 13.5m/s
Cut-in wind Speed	2.8m/s	Cut-out wind Speed	13.5m/s
Rated wind Speed	13.5m/s	Rated output	3kW @ 13.5m/s
Survival Wind Speed	50m/s	Rotor RPM	145 - 780rpm
		Maximum Power	3kW
Generator Output (three types)	3phase AC 30V-240V		
Generator	3phase permanent magnet generator of an 18 poles structure		

Each wind turbine has a MSN (Manufacture Serial Number) printed on the tower mount. In addition, all three blades also have their own BSN (Blade Serial Number) printed at the blade root. The MSN/BSN are also written on the delivery box.

We recommend writing it here as well:

The wind turbine system MSN: _____

Blade BSNs :1. _____ 2. _____ 3. _____

Date of Installation : _____

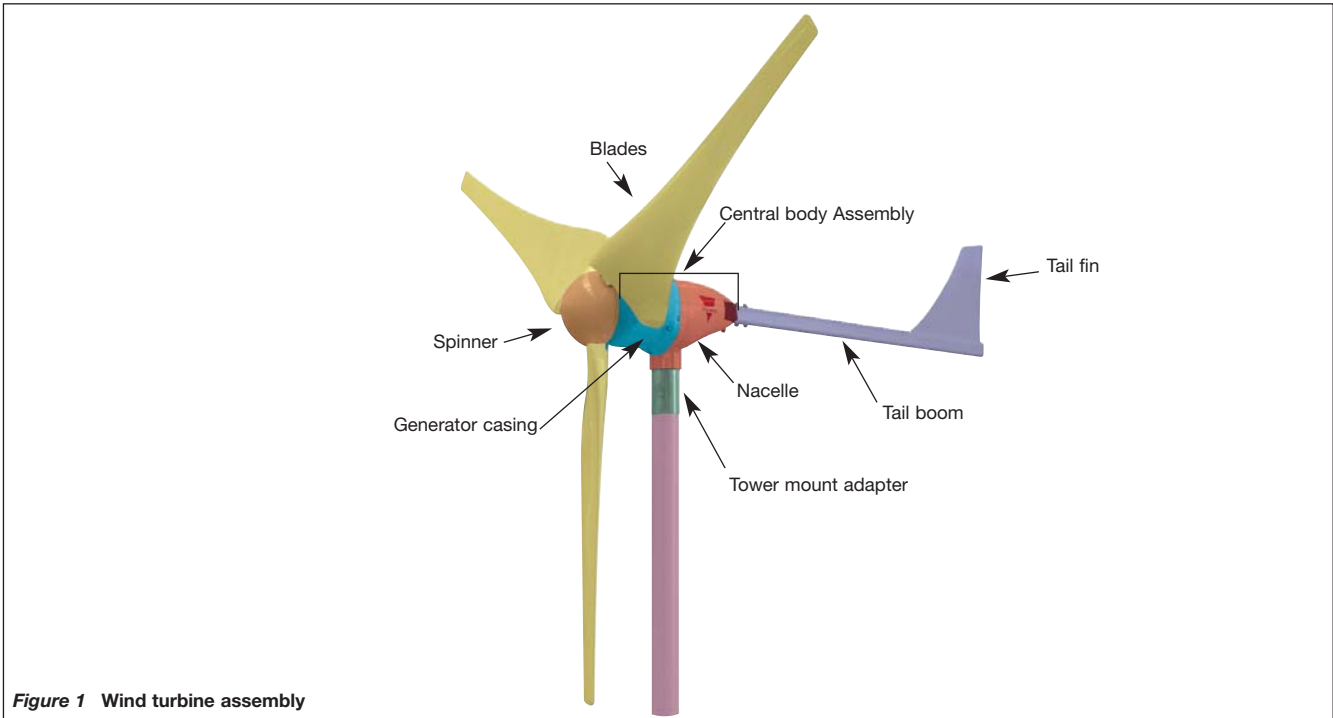
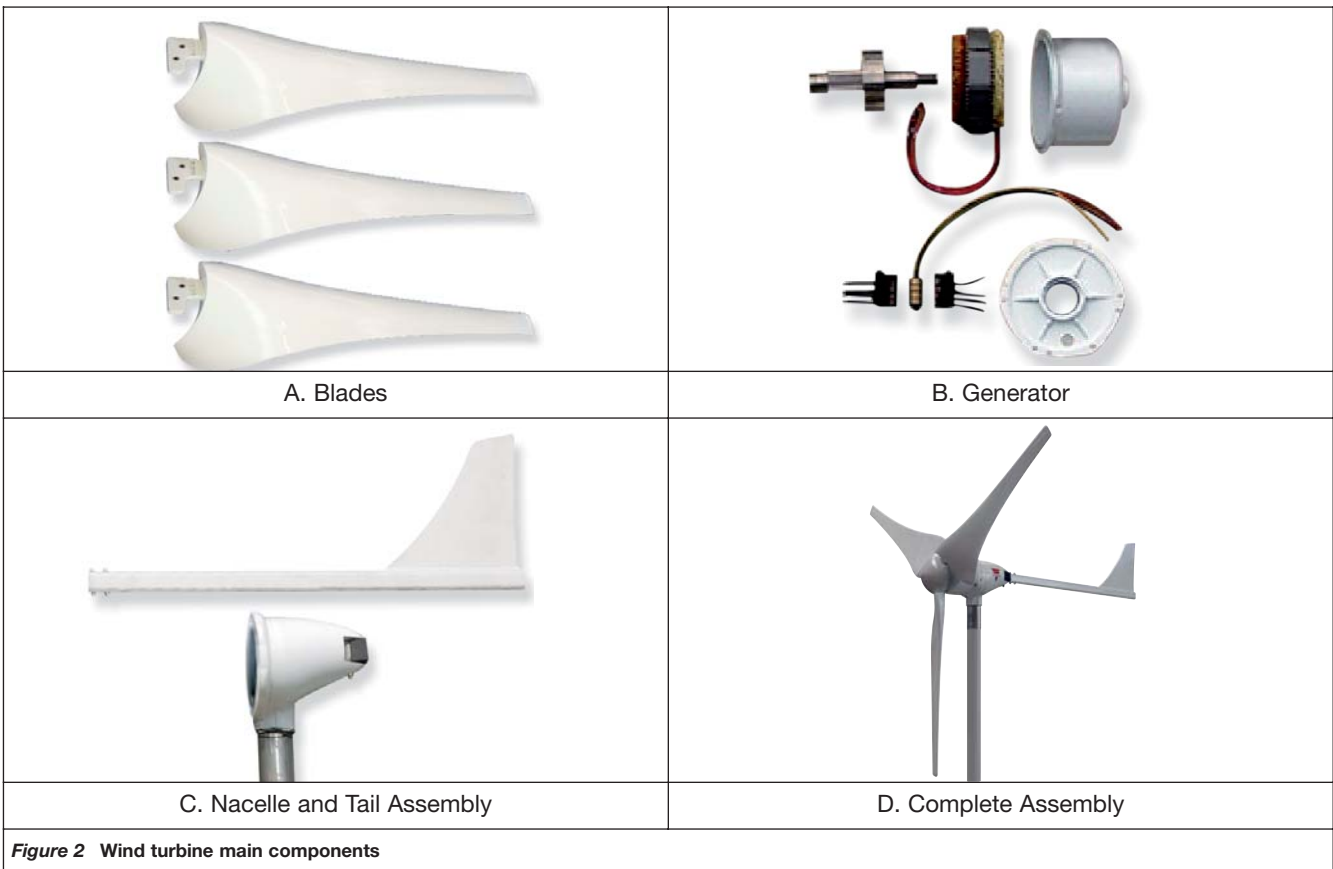

Figure 1 Wind turbine assembly



1-2 Wind Turbine Description

The main components of the wind turbine are shown as for Figure 2.

A. Blades / Rotor System

The rotor system consists of three glass/carbon fiber blades. The glass/carbon fiber blades are structurally strong because there are extra glass/carbon reinforcing fibers layers that hold the full length of the blade. The blades absorb the energy of the wind and convert them into rotational forces that drive the generator. The rotor system includes three blades because three blades will provide excellent balance between the cost and efficiency and can run much smoother than two blades rotor.

Warning!

The composites blades are very strong in tension, but they are susceptible to impact damage. They should be handled carefully to avoid any impact during installation.

B. Generator

The generator converts the rotational energy of the blade/rotor system into electricity. It is a 3-phase permanent magnet generator of an 18 poles structure. The generator is a completely new design for the wind power system and it produces power even at low rotating speeds. The output of the generator is three-phase variable-frequency alternating current (AC), and it can be rectified to direct current or connected to power grid through a grid-tied device.

C. Central Body Assembly

The central body assembly consists of the blade hub, generator casing, and the nacelle. It is the main structural “backbone” of the rotor system, the generator, the yaw bearings, slip-ring assembly, the tail, and the tower mount. The yaw bearings allow the wind turbine to turn around the top of the tower in order to head the wind. The slip-ring assembly is the electrical mean to connect the movable part of the wind turbine to the fixed tower wiring. The slip-rings and yaw bearings are located inside the tower mount. The tower mount attaches wind power system to the top of the tower through the tower mount adapter.

D. Tail Assembly and High-Wind Protect (Furl Protect) Function

The tail assembly, which includes the tail boom and tail fin, will keep the generator Assembly and rotor facing to wind at wind speeds less than about 13.5m/s. At wind speeds reaching approximately 13.5m/s, the High-Wind Protect function activates and turns the rotor partially away from the wind to prevent the rotor over-speed.. That allows the turbine to continue to generate electrical power before it reaching the safety shutdown control point in high winds. When the wind speed slower, the High-Wind Protect function will inactive and turn the turbine back to the heading wind position.

1-3 Grid-tied Wind Power Inverter Specifications



- DSP based fully digital control
- Converter ability 3.0kW/240V 50/60Hz
- High efficiency: 95% above.
- Maximum Power Point Tracking function
- Anti-Islanding
- LCD displays generation data & status
- High power conversion efficiency
- Easy installation

Input data

AC connection	3-phase
Voltage range	0...200VAC
Operating voltage range	30...180VAC
Max. current	18A

Environmental data

Operating temperature	-20...+40°C
Storage temperature	-25...+80°C
Cooling	Natural convection
Humidity	0...95% (non condensing)
Installation location	Indoor
Protection degree	IP43

Mechanical Data

User interface	LCD data display
Dimensions (HxWxD)	535x360x200mm
Weight	22.5kg

Output data

AC connection	1-phase
Nominal power	3kW
Max. power	3.6kW
AC voltage	230VAC ±5%
Frequency	50Hz
Max. current	14A
Power factor	>0.99 @ full load
Distortion factor THD	<3%
Max. efficiency	>95%

General data

Protection device	Grid monitoring system
Anti-islanding monitoring	Yes

Standard Norms and Certifications

UNI-EN Standard	EN50178, EC62103
VDE Standard	VDE0126-1-1
Certifications	CE: MD, LVD and EMC

1-4 Grid-tied Wind Power Inverter Description

This product is a wind energy utility grid-tied system. Single-phase grid-tied wind power inverter is different from traditional stand-alone type wind energy inverter, it does not need additional expensive and large space required energy storage battery, hence free from considerable battery maintenance expense. It efficiently converts power generated from wind turbine, high efficiently in to AC power to feed into grid, having the direct benefit of power generation and energy saving.

1-5 Wind Power System Operation

A. Normal Operation

The generator of wind power system should begin to generate electricity when the wind speed reaches approximately 3m/s. The rotor rotational speed will increase with higher wind speed. **The generator output is proportional to the third power of wind speed.** Please refer to Figure 4 for the relationship between power output and wind speed.

The inverter relays sequence (a1, a2 and b1, b2) after the start up is described in figure 3.

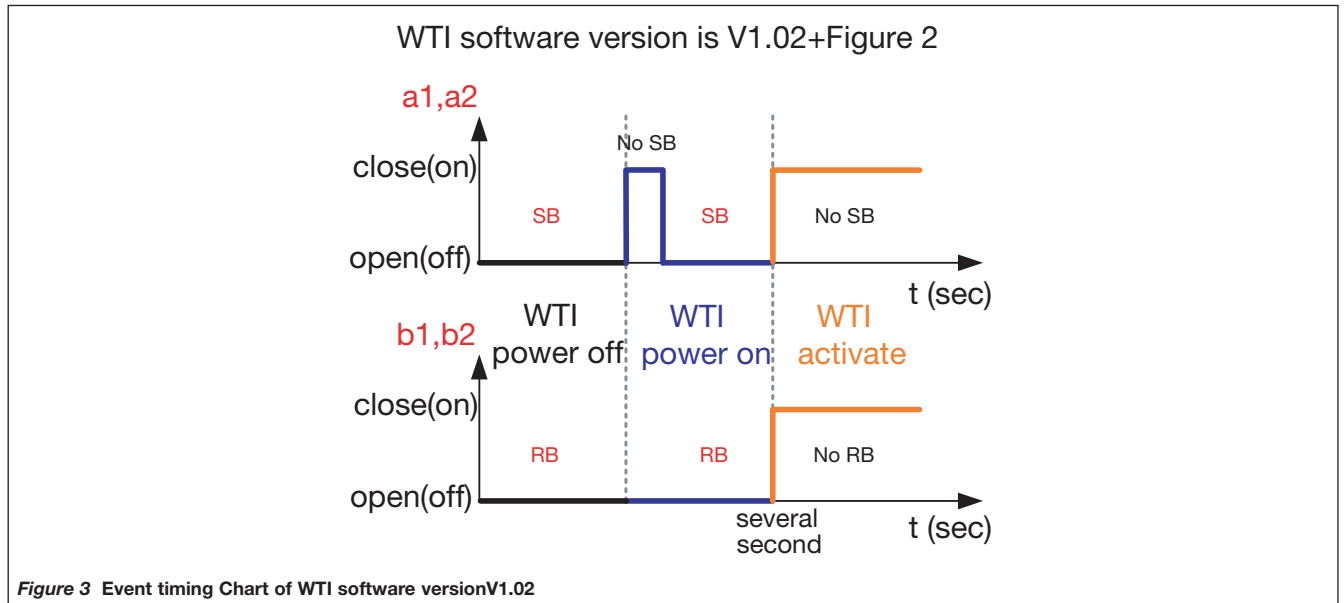

The basic intention is to keep the wind turbine braked until the full functionality of the inverter is warranty. After several seconds the relays are then energized allowing the wind turbine free to run.

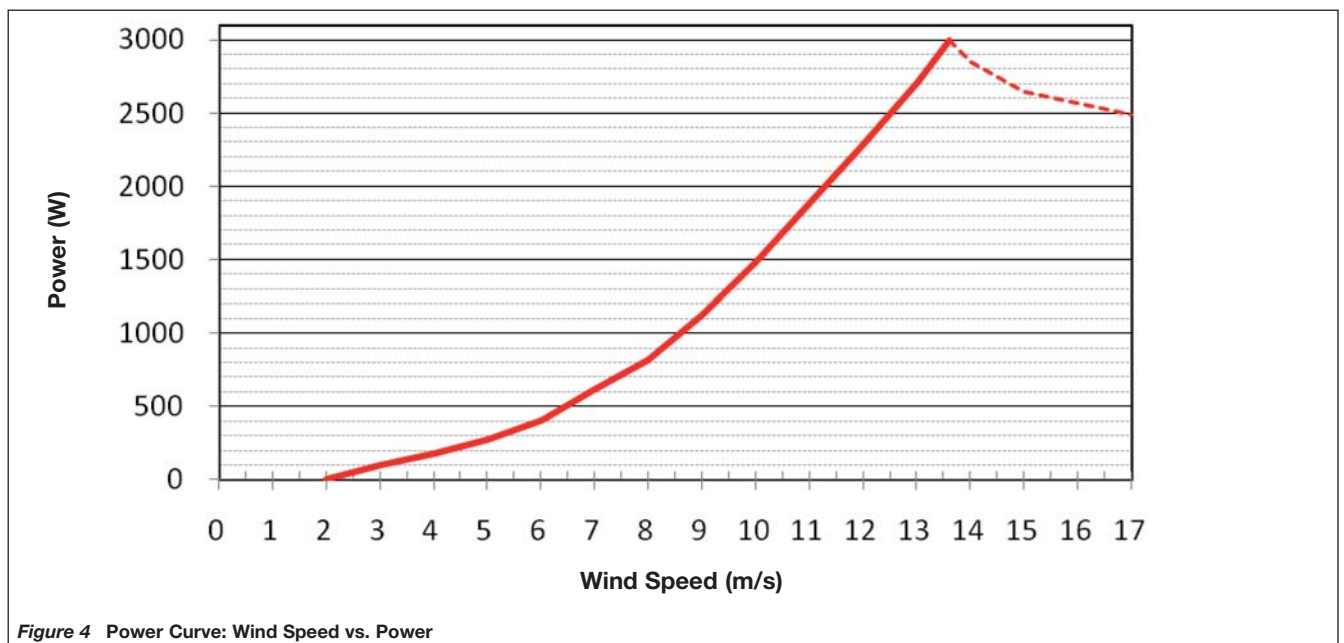

Note

The operational wind speeds and performance in the manual assume the condition of sea-level altitude, steady winds, and moderate temperatures. High altitude, hot temperatures, turbulence and gusting winds will usually bring the system performance lower than expectation.

B. High-Wind Protection (Furl Protection)

In case of high wind speeds, the High-Wind Protection Function system will protect the wind turbine automatically. When furled, the rotor will turn away from the wind direction, the rotor speed will reduce, and the power output of the turbine will be significantly reduced.

High-Wind Protection Function is an easy method to provide high wind speed protection. The High-Wind Protection Function is based on basic physical relationship between the aerodynamics, rotor, gravity, and the specially designed tail shape and weight balance of the wind power system.

The High-Wind Protection Function is completely passive, so it is very reliable. But there is one situation in the field that we have found it can disrupt the operation of High-Wind Protection Function:

if the wind turbine is installed on a sharp hill or next to a cliff so that the wind can come up through the rotor on an incline (e.g., from below; as opposed to horizontally) this will affect furling and can produce higher peak outputs. We strongly recommend avoiding this situation.

Caution

The weight distribution of the system is specially balanced. Any change of the system weight and balance, especially the tail, may cause malfunction of the High-Wind Protection Function.

Note

Additional Electromagnetic Brake Protection Function is provided by the electronic system controller, please refer to Chapter 4 Protection.

Chapter 2

Installation of Wind Power System

Caution

- To avoid danger, construction work and wiring must be done by professional personnel.
- The construction and wiring process must be in accordance with electrical engineering regulations.
- Please read this manual carefully and follow its instructions and recommendations.

2-1 Installation of Wind Turbine

Parts and Accessories List:

There are three shipping boxes for a complete set of wind turbine. Details are as follows,

Boxes	Description	Dimensions (L x W x H)	Weight
Box 1	Central body and Accessories	68cm x 48.5cm x 35cm	39.3kg
Box 2	Blades	123cm x 28cm x 36cm	13.0kg
Box 3	Tail assembly	155cm x 48cm x 5.5cm	6.2kg

Before Installation, please check the packing for the following items:

No.	Description	Specification	Q.ty (pcs)
1	Blade	1.2m / Material: Glass + Carbon fiber	3
2	Body	Permanent magnet synchronous generator	1
3	Spinner	Material: Nylon + Glass fiber	1
4	Tail Fin Plug		1
5	Tail Fin	Material: Zinc-coated steel	1
6	Stainless Steel Screw	Ø12mm x 60mm	6
7	Stainless Steel Nut	Ø12mm	10
8	Stainless Steel Flat Washer	Ø12mm	10
9	Stainless Steel Spring Washer	Ø12mm	12
10	Stainless Steel Screw	Ø8mm x 75mm	2
11	Stainless Steel Nut	Ø8mm	2
12	Stainless Steel Washer	Ø8mm	4
13	Stainless Steel Screw	Ø12mm x 130mm	2

Wind Turbine Assembly Procedure :

(1) Fasten the three blades into the circular hub using two 12mm-diameter, 60mm-long bolts for each blade. To refer Figure 5, firstly put one spring washer through the bolt, follow by one flat washer, insert them through the blade and hub, put another spring washer through the protruding part of the bolt, apply Loctite to the thread, and fasten with a nut. Press the spinner into the hub.

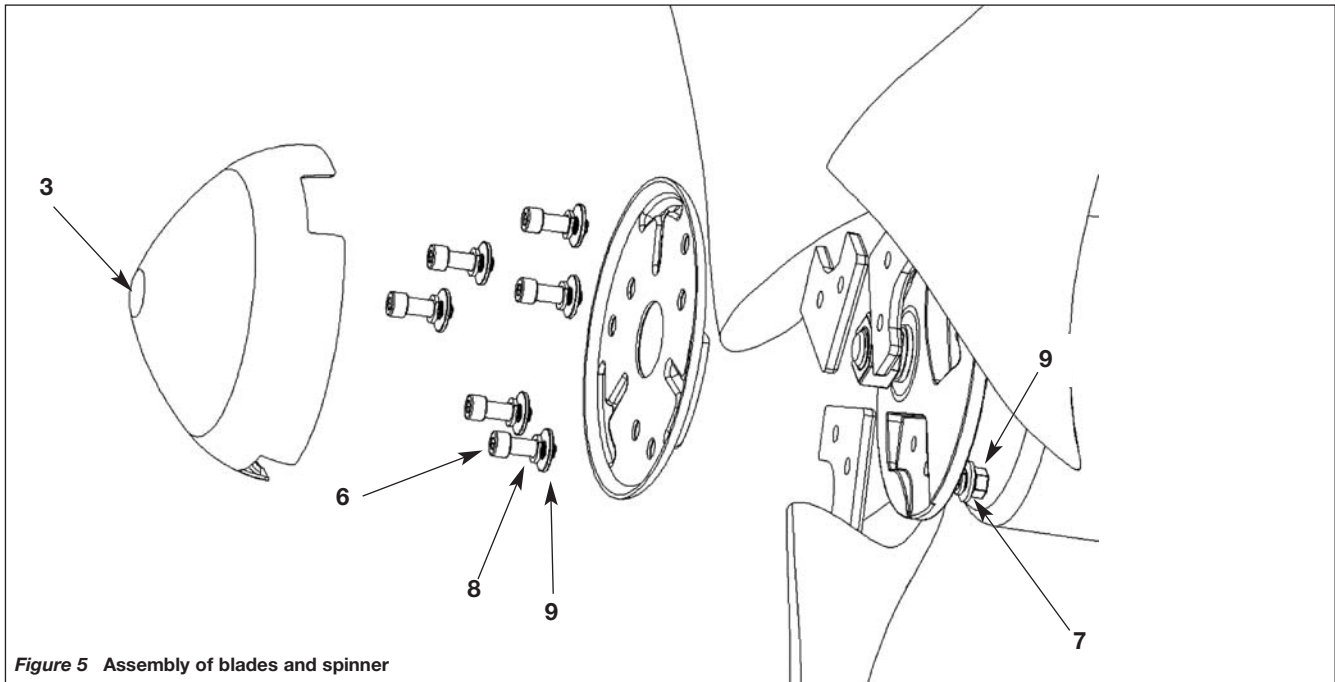

Figure 5 Assembly of blades and spinner

(2) Attach the tail assembly to the central body assembly using two 8mm-diameter bolts. To refer Figure 6, firstly put one flat washer through the bolt, insert them through the tail and nacelle, put another flat washer to the bolt, apply Loctite to the thread, and fasten with a nut.

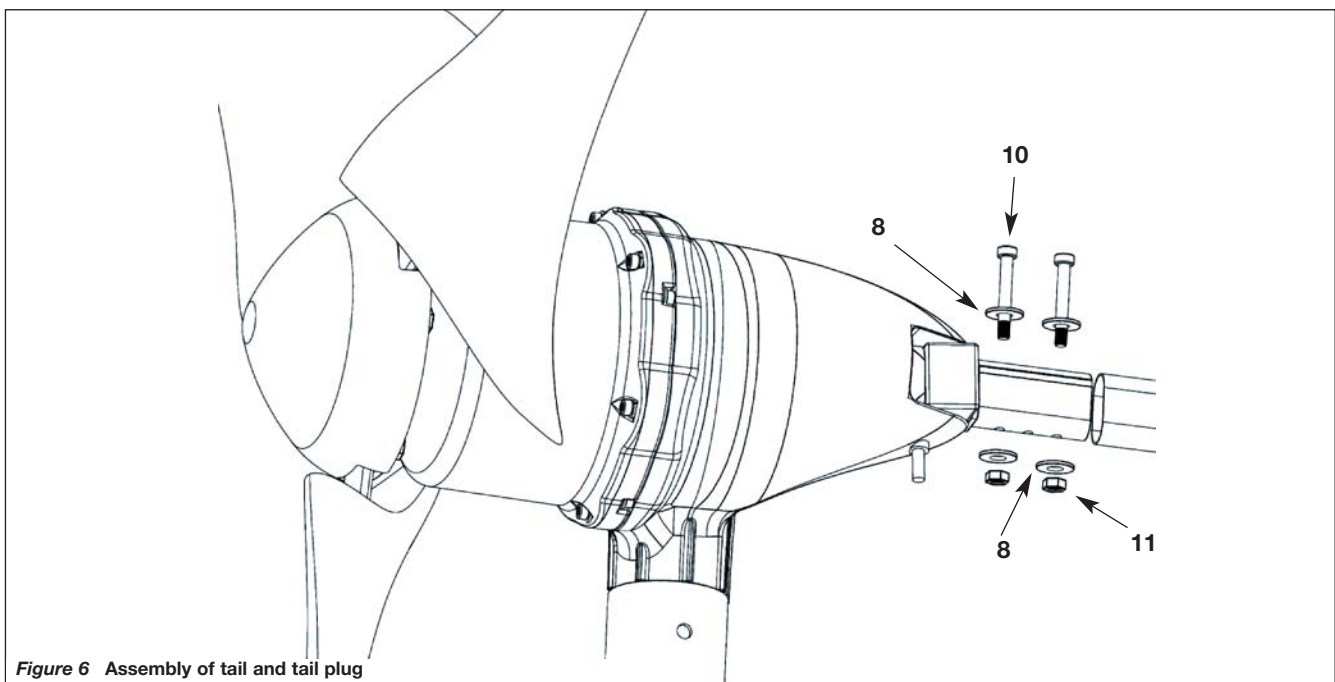

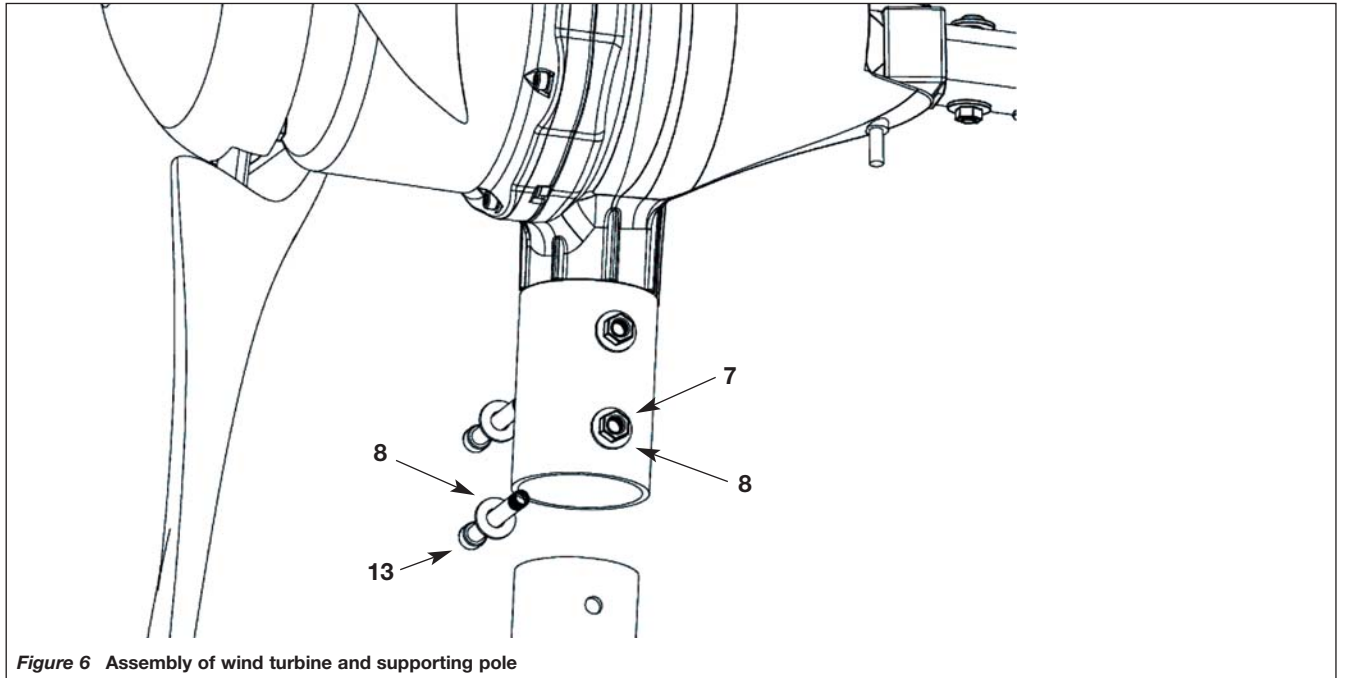

Figure 6 Assembly of tail and tail plug

(3) Attach the wind turbine power output wires to the power cable with insulated heat shrunk tube and straighten the cable. Put the supporting pole into the tower mount adapter using two 12mm-diameter, 130mm-long bolts. To refer Figure 7, firstly put one flat washer through the bolt, insert them through the adapter and pole, put another flat washer to the bolt, apply Loctite to the thread, and fasten with two nuts. ( Notice! Don't PRESS or DAMAGE wires when assemble supporting pole)



(4) Hoist the wind turbine and supporting pole into position, fasten the pre-installed foundation bolts with nuts and apply Loctite to the thread to complete the installation.

Support Tower Suggestion

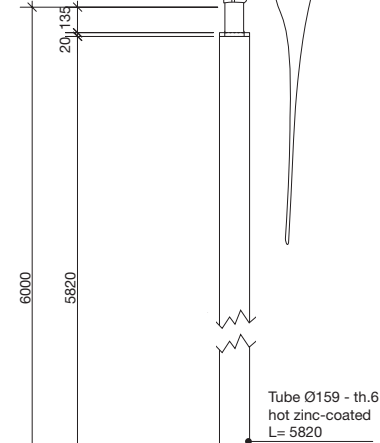
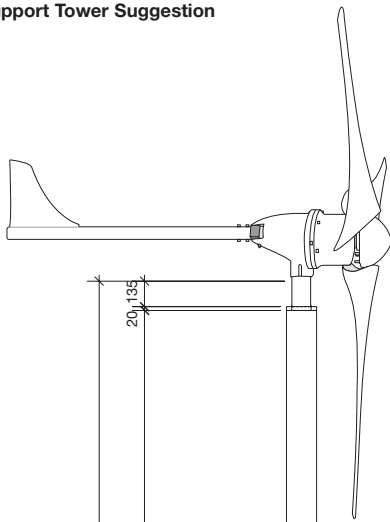

Tube Ø159 - th.6
hot zinc-coated
L= 5820

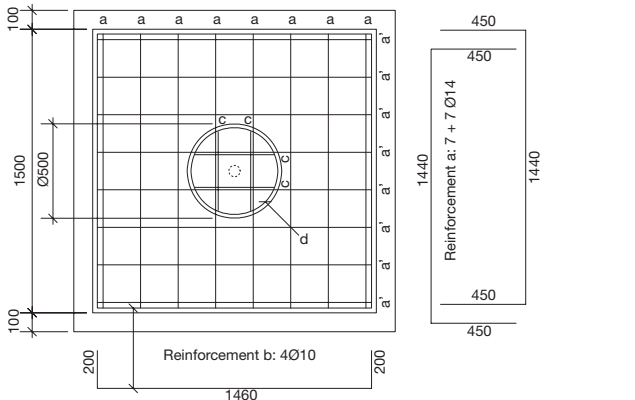
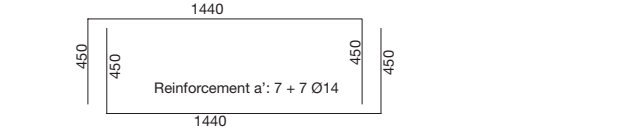
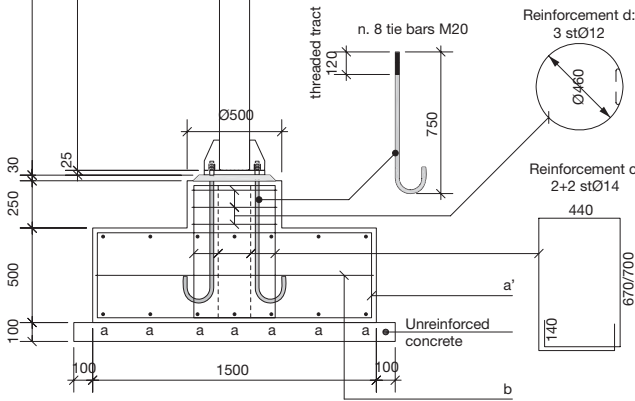

BILL OF MATERIALS

DESCRIPTION	DIMENSION (mm)	Q.TY	U.M.	TOTAL
excavation	2700x2700x800	1	m3	5,83
unreinforced concrete	1700x1700x100	1	m3	0,29
concrete C25/30 for plinth	1500x1500x500	1	m3	1,13
concrete C25/30 for plinth	(ttx250x250)x250	1	m3	0,05
quarterdeck	4x1500x500	1	m2	3,00
quarterdeck	2ttx250x250	1	m2	0,39
reinforcement "a" (o14)	2340	14	kg	39,57
reinforcement "a" (o14)	2340	14	kg	39,57
reinforcement "b" (o10)	1860	4	kg	4,59
reinforcement "c" (o14)	2970	4	kg	14,35
reinforcement "d" (o12)	1810	3	kg	4,81
pleated hose o60	1200	1	m	1,20
concrete mix EmacoS55	o400x30	1	it	3,80
tie bars oM20	950	8	kg	18,74
washer M20	-	8	n	8,00
screw nut M20	-	2x8	n	16,00
plate th.25	o320	1	kg	15,78
plate th. 6	80x160	4	kg	2,41
tube o159 th. 6	5824	1	kg	131,76
plate th. 20	o159	1	kg	3,12
tube o88,9 th.7	131	1	kg	1,91
metal sheet th.2	240x80	1	kg	0,30
screw M6	-	2	n	2,00

2-2 Installation of Grid-tied Wind Power Inverter

Installation Procedure of Inverter:

Conditions

Do not operate the Inverter in an environment where the ambient temperature is outside the limits given in the specifications of this manual. These inverter units are intended for use in a temperature-controlled, indoor area free of conductive contaminants. Select a location that will provide good air circulation for inverter at all times.

- **Placement**

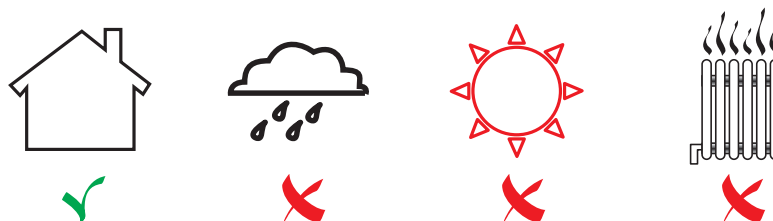

Mounting the Grid-tied Inverter on the wall

01. The mounting background must be firm.
02. The ambient temperature must be between -20°C and $+40^{\circ}\text{C}$.
03. Install at a shading roof, do not expose the inverter to direct sunlight.
04. Keep it in good ventilated situation; a minimum distance of 254mm (10") must be clear around the inverter.
05. The heat sink can reach a temperature of more than $+80^{\circ}\text{C}$. The air circulation must be sufficient for heat dissipation.
06. Provide a correct position of the inverter for mounting.
07. The inverter is mounted on the back side with the metal strap. (Figure 8)
08. Check mounting is firm.
09. Please ensure to install the grid-tied wind power inverter in a ventilated location. There should be no any stack around one meter of its surrounding.

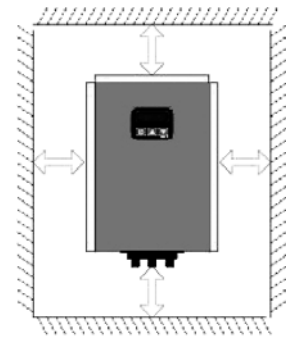
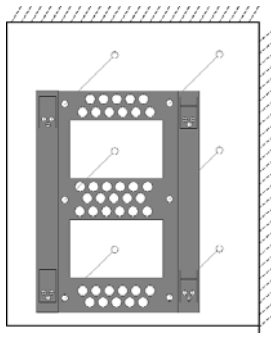
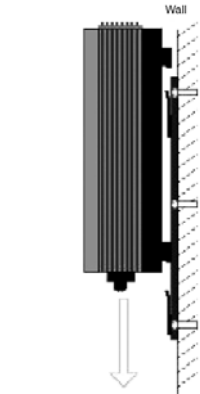
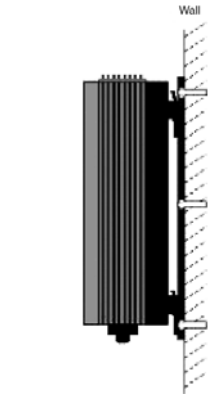
			
<p>STEP 1: Heat dissipation Keep a minimum distance of 203-304mm (8-12") clear around the inverter</p>	<p>STEP 2: Fix the metal strap Fixed six screws</p>	<p>STEP 3: Hang up</p>	<p>STEP 4: Check it firm</p>

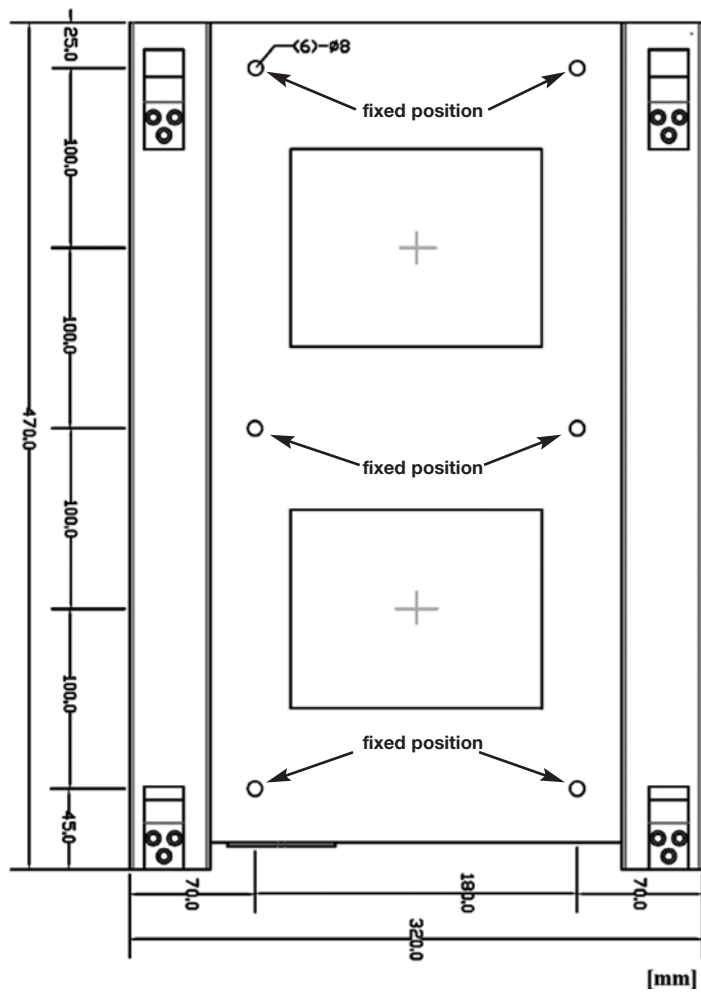

Figure 8 Metal strap of Inverter



Inputs/Outputs

Specifications

Figure 9 WT13 product label

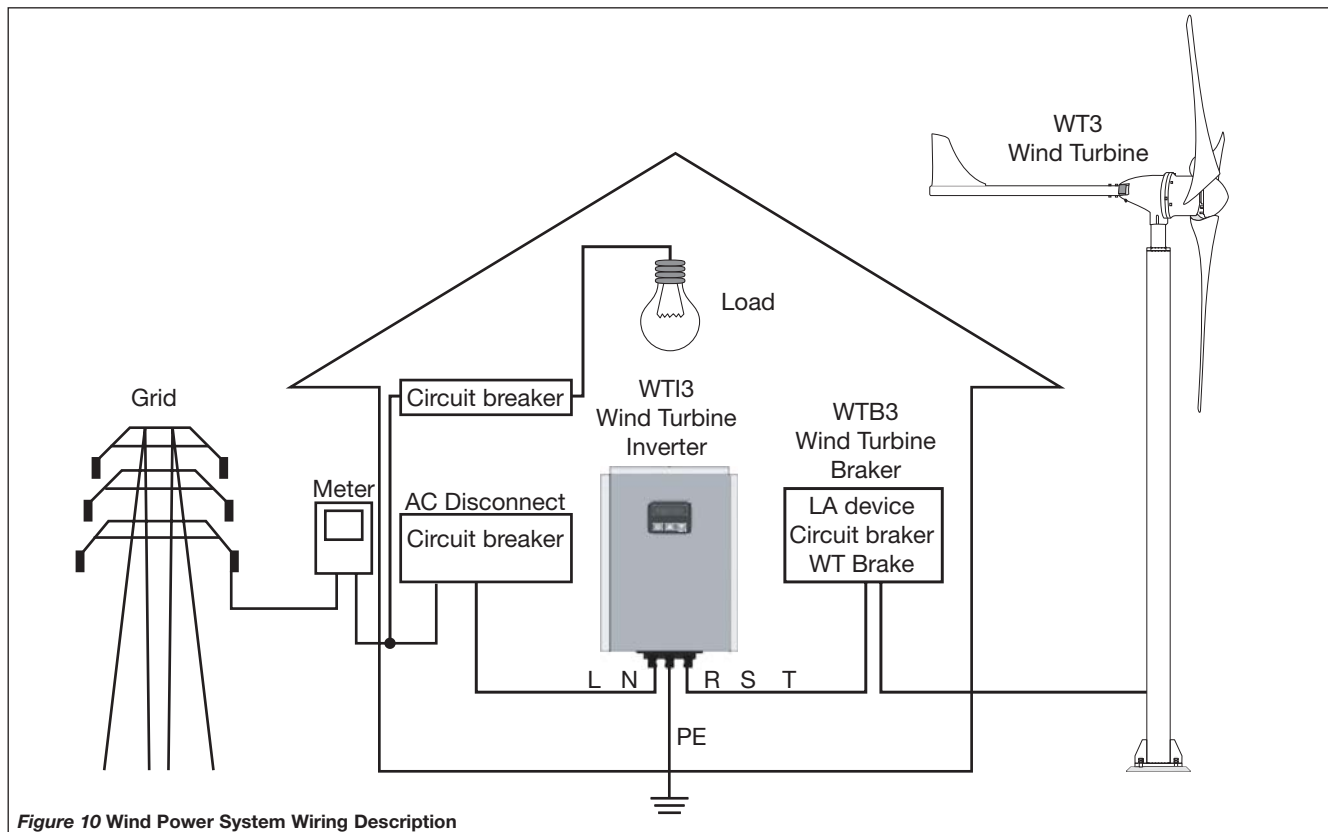

Figure 10 Wind Power System Wiring Description

Power Wire Size Selection

Please connect electrical wire according to each contact marked with description. Regulated wire size as follows: See detailed wiring diagram in Figure 13.

AC output wire use a size at least 12AWG (or 4mm²) black copper wire.

Wind turbine wires use at least 12AWG (or 4mm²) and above copper wire, these wires to be of different color in order to distinguish R, S, T 3phase power.

It is recommended to use 12AWG (or 4mm²) and above yellow/green copper wire on machine housing earthing (grounding) wire.

Notice of Wiring

- Before wiring, please finish installation of the wind power inverter, meanwhile, check and ensure that there is no fuse breaker of main distribution board is in close status.
- In order to ensure quality of electrical wiring. Please use a wire size recommended in this manual and in accordance with wiring standard of electrical regulations.
-  **Important!** : The GREEN wire of wind turbine is neutral wiring output from generator, it's for special application. Please leave GREEN wire isolated, don't wire it to any conductive goods.

2-3 Braking Box

Description

The typical configuration of the braking box and relative components are shown on figure 13. Depending on wind speed and plant condition, the inverter drives two different electrical brakes. Through the inverter outputs: a1, a2 and b1 and b2, the relays KM1-KM3 and KM4-KM6 are switched ON or OFF in order to prevent any damage on turbine and inverter. One brake is done by resistor R1-R3, and this is the dumping brake. If the wind is keeping an high speed for a long period of time beside the dumping brake will turn on by mean inverter outputs a1 and a2.

The braking box allows to apply a manual brake too through breakers QM2-QM3. These manual brakes are independent from the brakes a1, a2, b1 and b2.

The QM1 breaker is the main breaker of Mistral3k system from the grid, it allows to switch off the braking box and the inverter too.

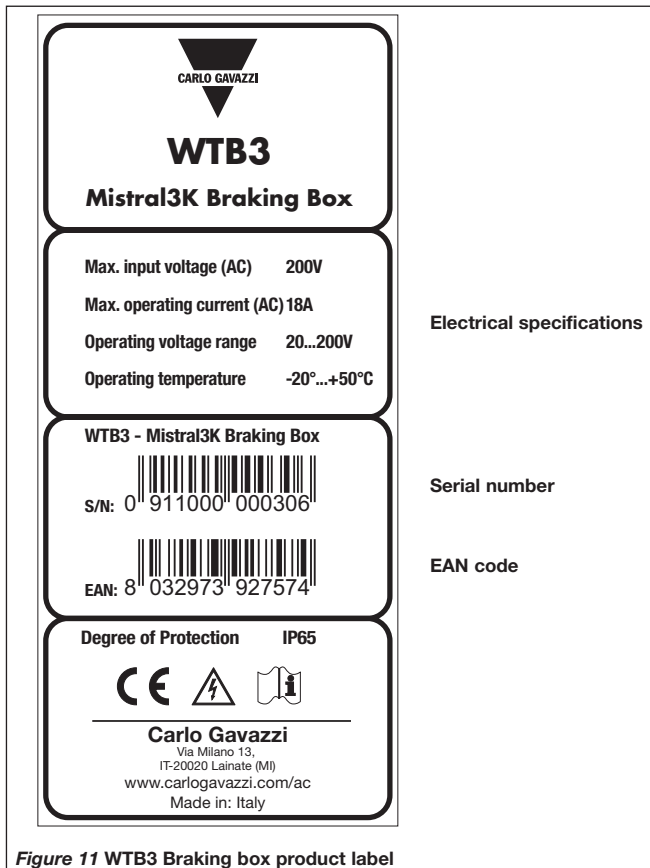

Figure 11 WTB3 Braking box product label

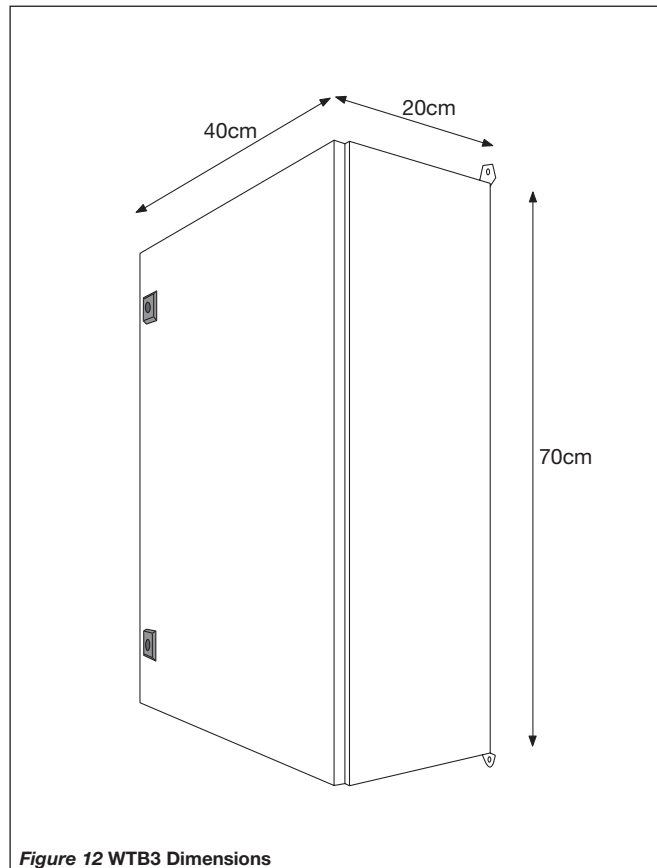

Figure 12 WTB3 Dimensions

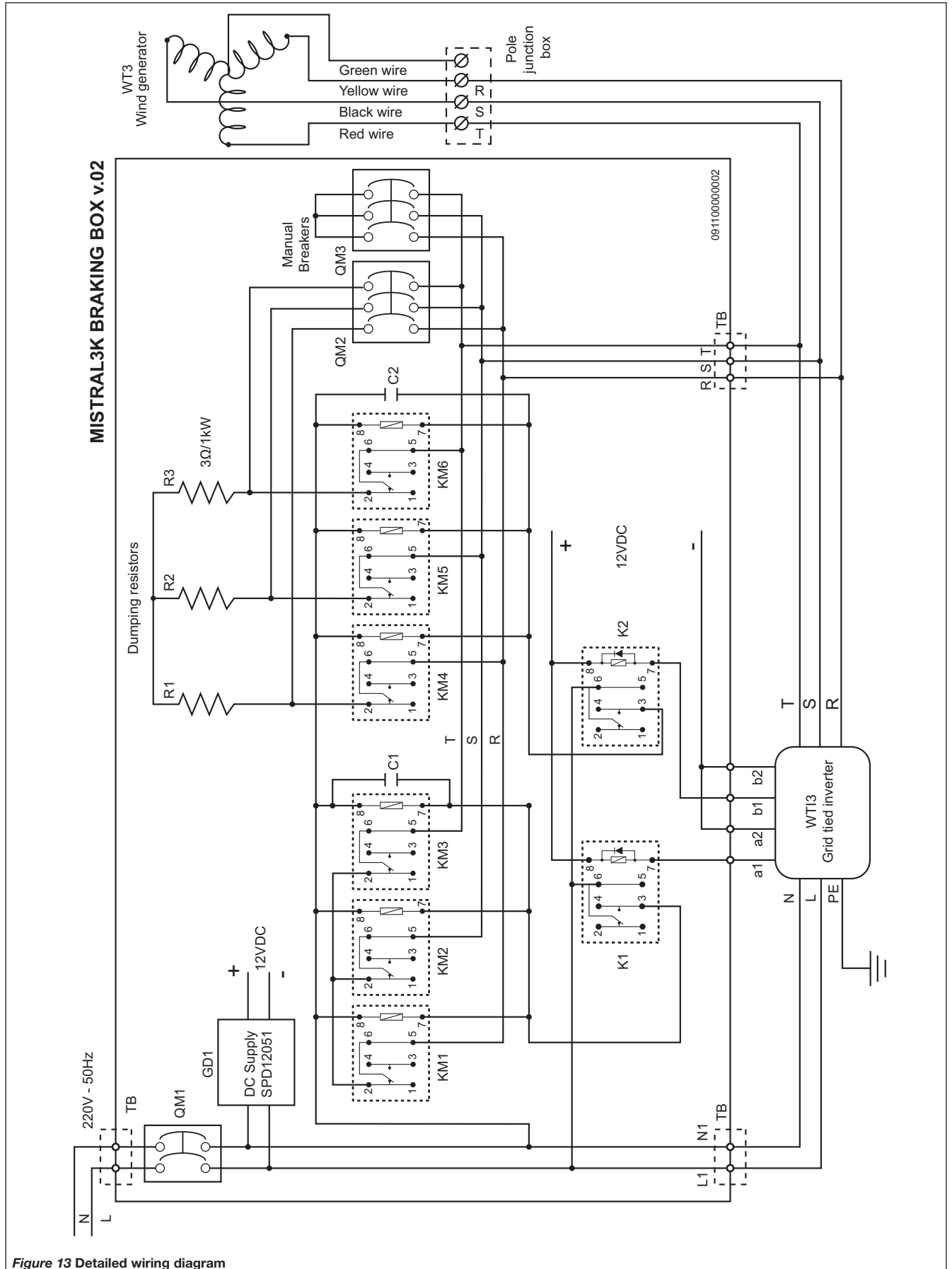

Figure 13 Detailed wiring diagram

AWG to Metric Wire Size Conversion Chart

AWG	Section (mm ²)	AWG	Section (mm ²)	AWG	Section (mm ²)	AWG	Section (mm ²)
5	16.77	9	6.63	13	2.63	17	1.04
6	13.30	10	5.26	14	2.08	18	0.82
7	10.55	11	4.17	15	1.65	-	-
8	8.37	12	3.31	16	1.31	-	-

Installation Procedure of Electrical Wire Control Box

01. When wiring, it is not necessary to open top cover of wind power inverter, ensure wiring is fixed well and there is no danger of coming loose.
02. As shown on Figure 13, there are nine wires from wind power inverter, they are R, S, T, L, N (12AWG), and a1, a2 (16AWG) short brake signal contact and b1, b2 (16AWG) resistor brake contact.
03. Wind turbine output R,S,T wire is connected respectively to manual brake switch, automatic brake switch and three relays' C contact then finally connected to wind power inverter. **(The GREEN wire of wind turbine is neutral wiring output from generator, it's for special application. Please leave GREEN wire isolated, don't wire it to any conductive goods.)**
04. The terminal block (European type) as for attachment is connected respectively to a1, a2, b1, b2 contact.
05. a1 and a2 connected to signal of automatic short circuit brake switch, b1 and b2 connected to signal of automatic resistor brake switch.
06. AC output is connected to connected to utility through bi-directional wattmeter.
07. Grounding wire (PE) connected to wind power inverter and system grounding, please avoid connecting grounding wire with main line and ensure grounding is properly done.
08. When adopting the third kind grounding, grounding resistor must be less then 10Ω.
09. Brake Resistor consists of three 3Ω/1kW; Y connection is connected to three relay b contact respectively.
10. Caution! When resistor brake occurs, it will cause heat. Installation location must be in a ventilated place.
11. Suggestion: L,N go through 1:1 isolation transformer to utility 220V/(50Hz or 60Hz).

Recommended specifications

01. Automatic short circuit brake switch: Consists of an electromagnetic switch. Main contact stands 35A and above, coil start voltage 220V.
02. Automatic resistor brake switch: Consists of three relays, each relay stands 30A and above, coil start voltage 220V.
03. Resistor box: Consists of three 3Ω/1KW for Y connection.
04. Lightning device: Capacity of lightning device is related to distance of wind turbine and power distribution board INVERTER, please refer to electrical engineering regulations.

Wiring Description of Inverter

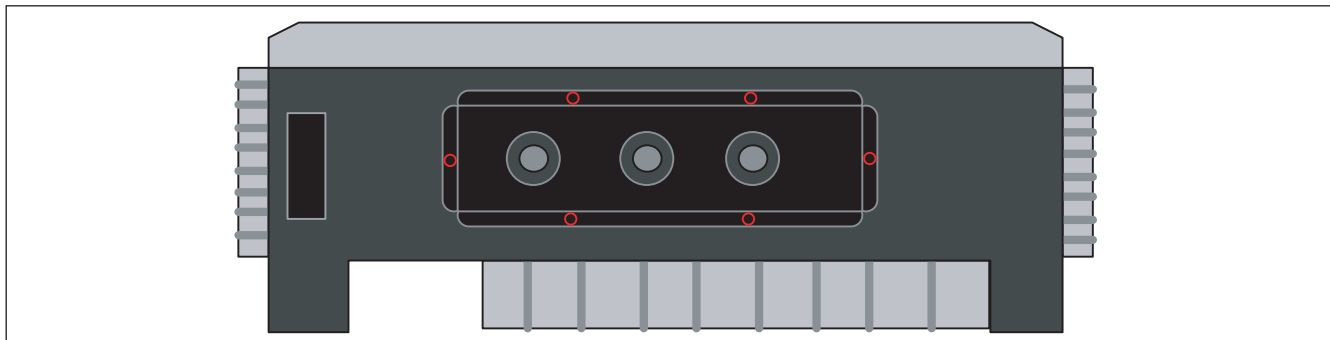

Loose six screws under the Inverter (as the red circle), after open it, there are two terminal block and node label.

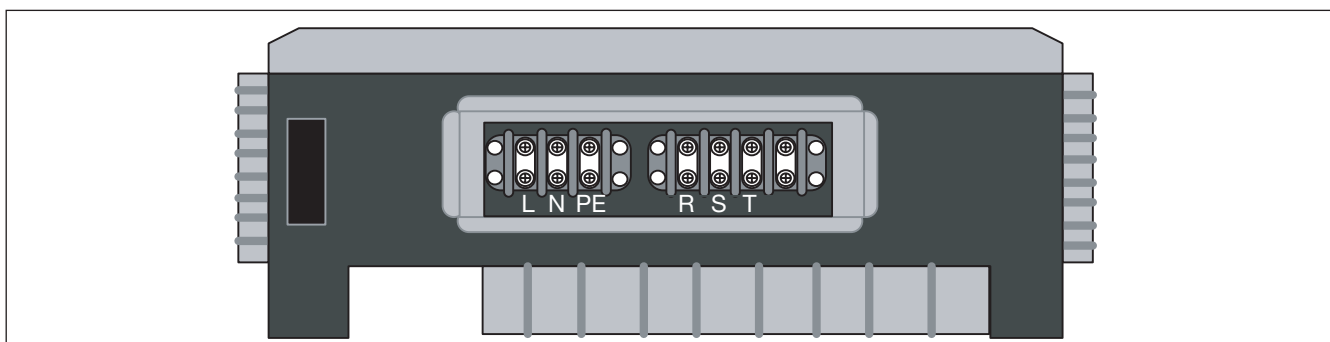

L and N are connected to utility AC power. R, S and T are connected to Wind turbine AC output. PE is grounding wire.

The wire connected to L is recommended to use 12 AWG (4mm²) and above. Suggest using brown color.

The wire connected to N is recommended to use 12 AWG (4mm²) and above. Suggest using blue color.

The wire connected to R is recommended to use 12 AWG (4mm²) and above. Suggest using red color.

The wire connected to S is recommended to use 12 AWG (4mm²) and above. Suggest using white color.

The wire connected to T is recommended to use 12 AWG (4mm²) and above. Suggest using black color.

The wire connected to PE is recommended to use 12 AWG (4mm²) and above. Suggest using yellow/green color.

Wiring show as below figure:

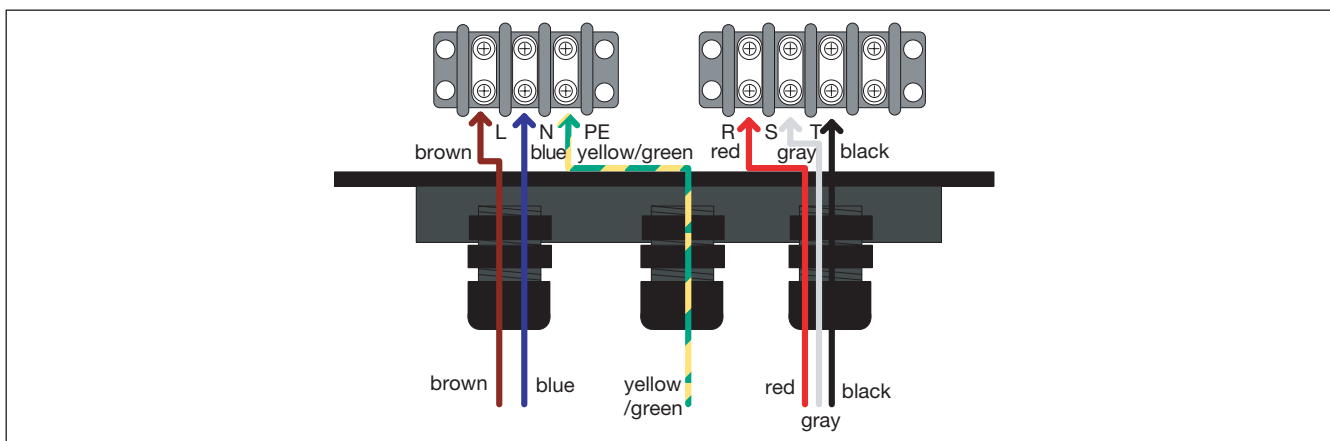

The brown and blue wires go through left spiral exclusive socket, connected tightly to L,N terminal respectively. The green wires go through medium spiral exclusive socket, connected tightly to PE terminal. The red, white and black wires go through right spiral exclusive socket, connected tightly to R,S and T terminal. Then lock six screws.

Show as below figure:

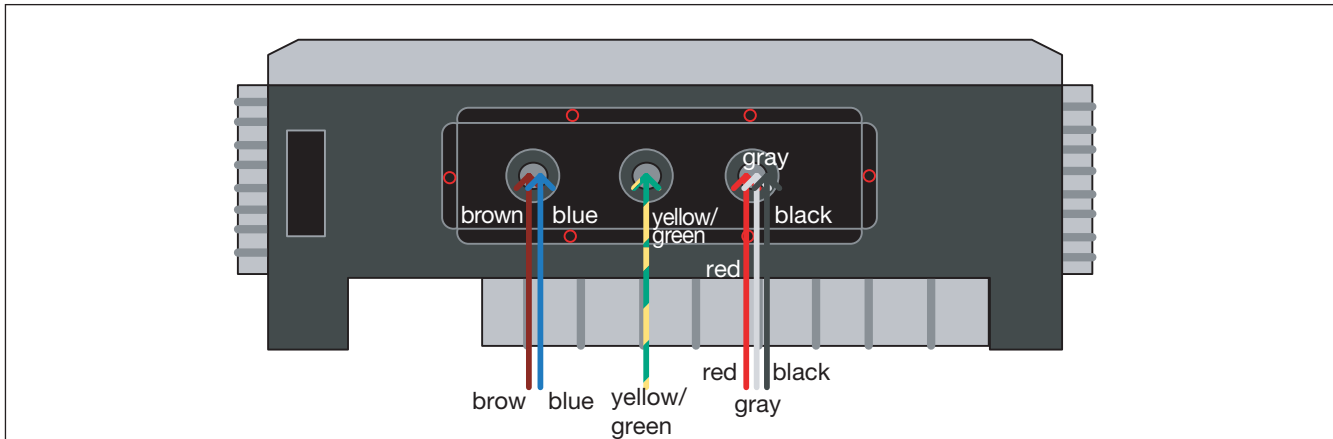





Chapter 3

Wind Power System Operation

3-1 Start Test

01. Ensure input voltage is within rated range by measuring the voltage on the input line.
02. Turn on the Main Breaker of Control Box, ensure utility voltage and frequency is within normal range.
03. Confirm the manual brake switch(NFB2,NFB3) turned to OFF.
04. Wind power inverter goes to switch-on screen, it will take a few minutes for the machine to do self-test and confirmation of utility voltage and frequency.
05. After output rated working range is confirmed, the wind turbine system will start to feed power to the utility. Then, the system operates automatically.

3-2 Instruction of Grid-tied Wind Power Inverter

	
	<p>Start / Close wind power inverter Switch [ON/OFF] to start/close wind power inverter. If [ON/OFF] is not pressed down, wind power inverter will automatically detect system, if the system works normally for 3 minutes, it will start to work automatically</p> <p>Close wind power inverter Press down [ON/OFF] for 2 seconds, buzzer sounds two short “beep” tone, wind power inverter will stay in standby, if [ON/OFF] is not pressed down again or power not re-started, the inverter will stay in standby.</p> <p>Start wind power inverter Press down [ON/OFF] for 3 seconds, buzzer sounds a long “beep” tone, the inverter has been started. If the whole system of utility and wind turbine is under normal condition, LCD will display [Waiting...]. If wind turbine produce energy to wind power inverter, inverter will begin conversion suitable energy to utility and wind turbine system operation normally. If wind energy isn't enough, there is no energy output, and LCD will display [Low wind].</p>
	<p>Default of wind power inverter will lock button key, if you need to look up internal parameter, [UP] and [DOWN] key must be pressed at the same time, buzzer will then sound two short “beep” tones, the locking of button key has been released.</p>
	<p>Shift-up key Shift-up key[UP] indicates cyclical moving upwards, display respectively Input power (Pi) → Input voltage/current (Vw/lw) → Output power (Po) → Output voltage/current (Vs/Is)</p>
	<p>Shift-down key Shift-down key[DOWN] indicates cyclical moving downwards, display respectively: Input power (Pi) ← Output voltage/current (Vs/Is) ← Output power (Po) ← Input voltage/current (Vw/lw)</p>

LCD Display List	
LCD display	Description
(Brand Name)	Display brand name.
(Model Number) Vx.x	Display model number and Vx.x: firmware version.
Waiting...	The status of wind turbine system is normally, waiting for wind energy feed-in, about 30sec.
LOW_WIND	When wind speed below 2.8m/sec, wind energy isn't enough to feed-in grid. The wind power inverter no power output.
record_No=xx	To show system fault record recently. When system is malfunction, there'll show corresponding fault record. If system power is off, the fault record will reset.
Vs=xxxV Is=xx.xA	Vs=xxxV: grid-tied voltage value(V). Is= xx.xA: grid-tied current value(A).
Po=xxxxW	Wind power inverter output power into grid(W).
Vw=xxxV Iw=xx.xA	Vw=xxxV: Wind power inverter internal DC bus voltage value(V). Iw= xx.xA: Wind power inverter internal DC bus current value(A).
Pi=xxxxW	The wind power output from wind turbine, and feed-in wind power inverter (W).

Chapter 4

Protection

4-1 Electromagnetic Brake Protection

This wind turbine system has two kind of electromagnetic brake protection function: **Resistor and Short-circuit Brake Protection**. Using wind power inverter and control box to perform this protection function.

01. Resistor Brake Protection:

When wind speed exceeds 13.5m/s, system will start resistor brake protection function. Then wind turbine will slow down even stop. When wind speed is lower than 10m/s, system will disable resistor brake protection function and wind turbine will operate normally.

02. Short Circuit Brake Protection: There are three conditions to perform this function.

- A. If resistor brake occurs continuously three times within 10 minutes, after 30 seconds upon the third time resistor brake occurs, short circuit brake actives for 2 minutes.
- B. If wind turbine rotational speed goes up after resistor brake active, after 30 seconds upon resistor brake occurs, short circuit brake actives for 2 minutes.
- C. If short circuit brake occurs continuously three times within 30 minutes, the third time short circuit brake will stay for 60 minutes.

4-2 High Wind Protection (Furl Protection)

The tail assembly, which includes the tail boom and tail fin, will keep the generator Assembly and rotor facing to wind at wind speeds less than about 13.5m/s. At wind speeds reaching approximately 13.5m/s, the High Wind Protect (Furl Protect) function actives and turns the rotor partially away from the wind to prevent the rotor over-speed. That allows the turbine to continue to generate electrical power before it reaching the safety shutdown control point in high winds. When the wind speed slower, the High-Wind Protect function will inactive and turn the turbine back to the heading wind position.

Chapter 5

Troubleshooting



This chapter description fault code of wind power inverter and inspection method.

Code	Display Message	Cause	Inspection
2	UTILITY FAULT	Utility power abnormal	<ul style="list-style-type: none"> • Check the connection between Inverter and utility. • Check utility voltage status.
3	DC VOLTS FAULT	Input Voltage is too high	<ul style="list-style-type: none"> • Wind speed too high cause over voltage.
9	Current error	Output current abnormal	<ul style="list-style-type: none"> • Check utility frequency and voltage status.
10	OVER Temp	Over temperature protection	<ul style="list-style-type: none"> • Was heatsink blocked or not? • Did the Inverter placed at ventilation position?
12	Line freq error	Grid frequency abnormal	<ul style="list-style-type: none"> • Check the connection between Inverter and utility. • Check utility frequency status.
13	OVER WG ERROR	WT over speed	<ul style="list-style-type: none"> • Wind speed too high cause over voltage.
14	OVER Pout	Over Load	<ul style="list-style-type: none"> • Inverter tripped, it'll automatic reset in a while.
15	DC V FAULT	Surge Voltage to high	<ul style="list-style-type: none"> • Was wind speed too high cause over voltage? The DC capacitor maybe burn out already.
16	Braking...R	Braking by resistor	<ul style="list-style-type: none"> • The resistor brake function actives now.
17	Braking...S	Braking by short circuit	<ul style="list-style-type: none"> • The short circuit brake function actives now.
23	GRID Vrms error	Utility voltage too high	<ul style="list-style-type: none"> • Was utility voltage over 10% normal voltage in a short time?
26	GRID Idc error	DC offset current to grid>1A	<ul style="list-style-type: none"> • Check the connection between Inverter and utility. Was there connected other load?
30	Leakage Current	Input device leakage current too high	<ul style="list-style-type: none"> • Were electrical wire broken somewhere? • Does the impedance too low between inverter case and wind generator coil?
41	UTILITY DET F	Frequency over range	<ul style="list-style-type: none"> • Check the connection between Inverter and utility. • Check utility frequency status.

Chapter 6

Spare Parts List



Code	Product Description
TW_BLADE	Mistral3k Wind Turbine Blade
TW_NACELLE	Mistral3k Wind Turbine Nacelle
TW_SPINNER	Mistral3k Wind Turbine Spinner
TW_TAIL	Mistral3k Wind Turbine Tail
WTI3	Mistral3k Inverter
WTB3	Mistral3K Braking Box

OUR SALES NETWORK IN EUROPE

AUSTRIA - Carlo Gavazzi GmbH
Ketzergasse 374, A-1230 Wien
Tel: +43 1 888 4112
Fax: +43 1 889 10 53
office@carlogavazzi.at

BELGIUM - Carlo Gavazzi NV/SA
Schaarbeeklei 213/3, B-1800 Vilvoorde
Tel: +32 2 257 4120
Fax: +32 2 257 41 25
sales@carlogavazzi.be

DENMARK - Carlo Gavazzi Handel A/S
Over Hadstenvej 38, DK-8370 Hadsten
Tel: +45 89 60 6100
Fax: +45 86 98 15 30
handel@gavazzi.dk

FINLAND - Carlo Gavazzi OY AB
Petaksentie 2-4, FI-00661 Helsinki
Tel: +358 9 756 2000
Fax: +358 9 756 20010
myynti@carlogavazzi.fi

FRANCE - Carlo Gavazzi Sarl
Zac de Paris Nord II, 69, rue de la Belle
Etoile, F-95956 Roissy CDG Cedex
Tel: +33 1 49 38 98 60
Fax: +33 1 48 63 27 43
french.team@carlogavazzi.fr

GERMANY - Carlo Gavazzi GmbH
Rudolf-Diesel-Strasse 23,
D-64331 Weiterstadt
Tel: +49 6151 81000
Fax: +49 6151 81 00 40
kontakt@gavazzi.de

GREAT BRITAIN - Carlo Gavazzi UK Ltd
7 Springlakes Industrial Estate,
Deadbrook Lane, Hants GU12 4UH,
GB-Aldershot
Tel: +44 1 252 339600
Fax: +44 1 252 326 799
sales@carlogavazzi.co.uk

ITALY - Carlo Gavazzi SpA -
Via Milano 13, I-20020 Lainate
Tel: +39 02 931 761
Fax: +39 02 931 763 01
info@gavazziacbu.it

NETHERLANDS - Carlo Gavazzi BV
Wijkermeerweg 23,
NL-1948 NT Beverwijk
Tel: +31 251 22 9345
Fax: +31 251 22 60 55
info@carlogavazzi.nl

NORWAY - Carlo Gavazzi AS
Melkeveien 13, N-3919 Porsgrunn
Tel: +47 35 93 0800
Fax: +47 35 93 08 01
gavazzi@carlogavazzi.no

PORTUGAL - Carlo Gavazzi Lda
Rua dos Jerónimos 38-B,
P-1400-212 Lisboa
Tel: +351 21 361 7060
Fax: +351 21 362 13 73
carlogavazzi@carlogavazzi.pt

SPAIN - Carlo Gavazzi SA
Avda. Iparraguirre, 80-82,
E-48940 Leioa (Bizkaia)
Tel: +34 94 480 4037
Fax: +34 94 480 10 61
gavazzi@gavazzi.es

SWEDEN - Carlo Gavazzi AB
V:a Kyrkogatan 1,
S-652 24 Karlstad
Tel: +46 54 85 1125
Fax: +46 54 85 11 77
gavazzi@carlogavazzi.se

SWITZERLAND - Carlo Gavazzi AG
Verkauf Schweiz/Vente Suisse
Sumpfstrasse 32,
CH-632 Steinhausen
Tel: +41 41 747 4535
Fax: +41 41 740 45 40
verkauf_vente@carlogavazzi.ch

OUR SALES NETWORK IN NORTH AMERICA

USA - Carlo Gavazzi Inc.
750 Hastings Lane,
USA-Buffalo Grove, IL 60089,
Tel: +1 847 465 6100
Fax: +1 847 465 7373
sales@carlogavazzi.com

CANADA - Carlo Gavazzi Inc.
2660 Meadowvale Boulevard,
CDN-Mississauga Ontario L5N 6M6,
Tel: +1 905 542 0979
Fax: +1 905 542 22 48
gavazzi@carlogavazzi.com

CANADA - Carlo Gavazzi LTEE
3777 Boulevard du Tricentenaire
Montreal, Quebec H1B 5W3
Tel: +1 514 644 2544
Fax: +1 514 644 2808
gavazzi@carlogavazzi.com

OUR SALES NETWORK IN ASIA AND PACIFIC

SINGAPORE - Carlo Gavazzi Automation
Singapore Pte. Ltd.
61 Tai Seng Avenue
#05-06 UE Print Media Hub
Singapore 534167
Tel: +65 67 466 990
Fax: +65 67 461 980

MALAYSIA - Carlo Gavazzi Automation
(M) SDN. BHD.
D12-06-G, Block D12,
Pusat Perdagangan Dana 1,
Jalan PJU 1A/46,
47301 Petaling Jaya, Selangor, Malaysia
Tel: +60 3 7842 7299
Fax: +60 3 7842 7399

CHINA - Carlo Gavazzi Automation
(China) Co. Ltd.
Rm. 2308 - 2310, 23/F.,
News Building, Block 1,
1002 Shennan Zhong Road,
Shenzhen, China
Tel: +86 755 83699500
Fax: +86 755 83699300

HONG KONG - Carlo Gavazzi
Automation Hong Kong Ltd.
Unit 3 12/F Crown Industrial Bldg.,
106 How Ming St., Kowloon,
Hong Kong
Tel: +852 23041228
Fax: +852 23443689

OUR COMPETENCE CENTRES & PRODUCTION SITES

Carlo Gavazzi Industri A/S
Hadsten - **DENMARK**

Carlo Gavazzi Ltd
Zejtun - **MALTA**

Carlo Gavazzi Controls SpA
Belluno - **ITALY**

Uab Carlo Gavazzi Industri Kaunas
Kaunas - **LITHUANIA**

Carlo Gavazzi Automation
(Kunshan) Co., Ltd.
Kunshan - **CHINA**

HEADQUARTERS

Carlo Gavazzi Automation SpA
Via Milano, 13 - I-20020
Lainate (MI) - **ITALY**
Tel: +39 02 931761
info@gavazzi-automation.com



Sense



Switch



Control



Safety



Fieldbus

CARLO GAVAZZI
Automation Components

Further information on
www.gavazziautomation.com www.carlogavazzi.com

CARLO GAVAZZI