

*Describing  
Synthesizable RTL  
in SystemC*

*Version 1.0, May 2001*

## **Trademarks and Copyright**

Synopsys and CoCentric are a registered trademarks of Synopsys, Inc. with further information at <http://synopsys.com>.

All other product or company names may be trademarks of their respective owners.

Copyright © 2001 Synopsys, Inc.

# Contents

---

- About This Guide . . . . . x
- SystemC Training . . . . . xi
- Information About Synopsys SystemC Synthesis Products . . . . . xii
  
- 1. SystemC RTL Synthesis Overview
  - System-Level Design . . . . . 1-2
  - System-Level Design Challenges . . . . . 1-2
    - Component Integration . . . . . 1-2
    - Tool Interoperability . . . . . 1-3
    - Design Team Collaboration . . . . . 1-3
  - SystemC . . . . . 1-4
  - Why Synthesis From SystemC? . . . . . 1-5
    - Interpretation Errors . . . . . 1-5
    - Verification Reuse . . . . . 1-6
    - Increased Productivity . . . . . 1-6
  - About This Manual . . . . . 1-7

## 2. Creating SystemC Modules for RTL Synthesis

Defining Modules and Processes . . . . .	2-2
Modules . . . . .	2-2
Processes . . . . .	2-3
Registering a Process . . . . .	2-3
Triggering Execution of a Process . . . . .	2-4
Reading and Writing Processes . . . . .	2-4
Types of Processes . . . . .	2-4
Creating a Module . . . . .	2-5
Module Header File . . . . .	2-5
Module Syntax . . . . .	2-6
Module Ports . . . . .	2-6
Port Syntax . . . . .	2-7
Port Data Types . . . . .	2-8
Signals . . . . .	2-8
Signal Syntax . . . . .	2-9
Signal Data Types . . . . .	2-9
Data Member Variables . . . . .	2-10
Creating a Process in a Module . . . . .	2-11
Defining the Sensitivity List . . . . .	2-12
Defining a Level-Sensitive Process . . . . .	2-12
Incomplete Sensitivity Lists . . . . .	2-13
Defining an Edge-Sensitive Process . . . . .	2-13
Limitations for Sensitivity Lists . . . . .	2-14
Member Functions . . . . .	2-15
Module Constructor . . . . .	2-15
Implementing the Module . . . . .	2-15

Reading and Writing Ports and Signals . . . . .	2-16
Reading and Writing Bits of Ports and Signals . . . . .	2-16
Signal and Port Assignments. . . . .	2-17
Variable Assignment . . . . .	2-18
Creating a Module With a Single SC_METHOD Process . . . . .	2-20
Creating a Module With Multiple SC_METHOD Processes . . . . .	2-22
Creating a Hierarchical RTL Module . . . . .	2-26
The Basics of Hierarchical Module Creation . . . . .	2-26
Hierarchical RTL Module Example . . . . .	2-28
3. Using the Synthesizable Subset	
Converting to a Synthesizable Subset . . . . .	3-2
SystemC and C++ Synthesizable Subsets . . . . .	3-2
Nonsynthesizable SystemC Constructs . . . . .	3-3
Nonsynthesizable C/C++ Constructs . . . . .	3-4
Refining Data. . . . .	3-7
Nonsynthesizable Data Types . . . . .	3-8
Recommended Data Types for Synthesis . . . . .	3-8
Using SystemC Data Types. . . . .	3-11
Bit Vector Data Type Operators . . . . .	3-11
Fixed and Arbitrary Precision Data Type Operators. . . . .	3-12
Using Enumerated Data Types . . . . .	3-13
Using Aggregate Data Types. . . . .	3-13
Using C++ Data Types. . . . .	3-13
Data Members of a Module . . . . .	3-14

Recommendations About Refinement for Synthesis . . . . .	3-16
4. RTL Coding Guidelines	
Register Inference . . . . .	4-2
Flip-Flop Inference . . . . .	4-2
Simple D Flip-flop . . . . .	4-2
D Flip-Flop With an Active-High Asynchronous Set or Reset . . . . .	4-4
D Flip-Flop With an Active-Low Asynchronous Set or Reset . . . . .	4-5
D Flip-Flop With Synchronous Set or Reset . . . . .	4-8
Inferring JK Flip-Flops . . . . .	4-10
Inferring Toggle Flip-Flops . . . . .	4-13
Latch Inference . . . . .	4-16
Inferring a D Latch From an If Statement . . . . .	4-16
Inferring an SR Latch . . . . .	4-17
Avoiding Latch Inference . . . . .	4-19
Inferring a Latch From a Switch Statement . . . . .	4-21
Active-Low Set and Reset . . . . .	4-25
Active-High Set and Reset . . . . .	4-27
D Latch With an Asynchronous Set and Reset . . . . .	4-28
D Latch With an Asynchronous Set . . . . .	4-29
D Latch With an Asynchronous Reset . . . . .	4-30
Three-State Inference . . . . .	4-32
Simple Three-State Inference . . . . .	4-32
Registered Three-State Drivers . . . . .	4-34

State Machines . . . . .	4-37
State Machine With a Common Computation Process . . . . .	4-39
State Machine With Separate Computation Processes . . . . .	4-41
Moore State Machine . . . . .	4-43





# Preface

---

This preface includes the following sections:

- [About This Guide](#)
- [SystemC Training](#)
- [Information About Synopsys SystemC Synthesis Products](#)

---

## About This Guide

The *Describing Synthesizable RTL in SystemC* describes how to develop a SystemC RTL model for synthesis.

For information about SystemC, see the Open SystemC Community web site at <http://www.systemc.org>.

---

## Related Publications

For information about the SystemC language and syntax, see the *SystemC User's Manual* available from the Open SystemC Community web site at <http://www.systemc.org>.

---

## Comments About This Document

E-mail your comments about this document to [techpubs-sld@synopsys.com](mailto:techpubs-sld@synopsys.com).

---

## Typographical Conventions

Courier font is used in this document to distinguish SystemC code examples.

---

## SystemC Training

For information about SystemC training and private workshops, contact

- Willamette HDL

<http://www.whdl.com>

Three-day *SystemC for High-Level Synthesis*

Three-day *Modeling With SystemC*

- Transfer

<http://www.transfer.nt>

Three-day *Modeling With SystemC*

- Fraunhofer IIS-A

<http://www.iis.fhg.de>

Three-day *SystemC Training Classes*

- Doulos

Five-day *Comprehensive SystemC Training Class*

<http://www.doulos.com>

- Blue Pacific Computing

<http://www.bluepc.com>

Three-Day *SystemC Workshop*

---

## Information About Synopsys SystemC Synthesis Products

For information about Synopsys SystemC synthesis products, contact your local Synopsys sales office or

- Go to the Synopsys Web page at <http://www.synopsys.com>
- In the Synopsys Products field, choose CoCentric™ SystemC Compiler

# 1

## SystemC RTL Synthesis Overview

---

This chapter describes how RTL synthesis from SystemC fits into the system-level design flow. It contains the following sections:

- [System-Level Design](#)
- [System-Level Design Challenges](#)
- [SystemC](#)
- [Why Synthesis From SystemC?](#)

---

## System-Level Design

System-level design involves specifying the system, verifying its functionality, and determining optimum system architecture by evaluating design alternatives. Today's complex systems have significant software content and are integrated into a system on a chip (SoC).

System-level design can help with the growing complexity of both the hardware and software. An effective system-level design strategy minimizes late design iterations and increases design team productivity, which enables you to deliver a high quality product on time.

---

## System-Level Design Challenges

Developing an effective system-level design strategy presents several challenges that can be solved by using SystemC.

---

### Component Integration

Component reuse is a widely implemented strategy for handling complexity, but many of the components are provided from various sources.

Because component models are written in different languages and styles, integrating the models into the system design is often so difficult the system designers avoid doing it, eliminating the important task of specification and functional verification.

---

## **Tool Interoperability**

Although system modeling tools are available, each tool uses a proprietary model format, which makes a model developed for one tool unsuitable for use with another tool. This lack of tool interoperability and model compatibility also prevents using more than one tool in a design flow.

---

## **Design Team Collaboration**

During system architecture design, designers choose the processor(s), bus, and peripherals, and decide what to implement in hardware and software. Effective architecture design requires participation of the hardware and software design teams for creating models and influencing architectural decisions, which is called hardware-software co-design. Furthermore, as the hardware and software design teams participate in architecture design concurrently, communication and consensus is reached early in the design cycle. The results of this collaboration must be validated and corrections can be made early in the design cycle. This prevents surprises when the hardware and software are integrated much later in the design cycle. To further complicate the situation, the system designers, hardware designers, and software engineers often apply different design languages. A common design language is needed to increase understanding, communication, and productivity, and to bring these teams together during the system architecture design phase.

---

## SystemC

SystemC is the foundation for design tools and methodologies that address the above mentioned the system-level design challenges of tool interoperability, team communication, and component model creation and distribution.

SystemC is based on C++, the most popular language with system designers and software engineers. The SystemC classes add the necessary constructs to C++ for modeling systems and hardware at various levels of abstraction—from the abstract untimed models to cycle-accurate RTL models. The software content of the system can be written in C++, without the need for additional constructs.

SystemC, by itself, solves only a few of the system-level design challenges. You can use SystemC for creating an executable specification to verify the system functionality and architecture, but analysis and architecture design tools are needed and IP vendors need to provide SystemC models.

The power of SystemC is that it can be used as a common language by system designers, software engineers, and hardware designers. SystemC allows exchange of IP models, creation of an interoperable tool infrastructure, and development of a concept-to-implementation design methodology. The same benefits derived from the standardization of Verilog and VHDL in RTL design can now be achieved in the system design space with SystemC.



---

## Why Synthesis From SystemC?

Hardware design has the well-established Verilog and VHDL hardware description languages with tools and design flows based on them. Why should you bother to understand how to use SystemC, a system design language, for hardware design and synthesis?

Consider a scenario where a system designer has created an architectural model of a SoC in SystemC and you are a hardware designer. The architectural model contains a variety of models, including processor models, abstract bus models, and peripheral models. The peripheral models capture the full functionality and interface of the peripherals, although at a high level of abstraction. This allows the system designer to hand you the peripheral models as an executable specification, along with written requirements for the area, speed, and power consumption for the peripherals.

---

### Interpretation Errors

You need to implement the peripherals and verify the implementation in the context of the entire system. If you use a Verilog or VHDL synthesis tool, you need to rewrite the peripheral models in Verilog or VHDL, which is a time-consuming and error-prone process. Or you can synthesize the peripheral models from SystemC. Instead of throwing away the work done at the system level and recoding the design, you can take the abstract, non-synthesizable peripheral models and refine them into synthesizable models.

---

## Verification Reuse

As an added advantage, you can use the system-level verification environment to check the correctness of your implementation as you refine it.

---

## Increased Productivity

If a hardware designer receives a SystemC executable specification, implementation from SystemC gives higher designer productivity than recoding it in Verilog or VHDL. Higher designer productivity comes from two sources—refinement is faster than recoding, and verifying a refined design is faster than verifying a recoded HDL design.

Refinement is faster than recoding, because hardware functionality is envisioned as either an algorithm or a finite state machine and data path, even if the description is abstract. Algorithmic models can be synthesized using behavioral synthesis techniques, and finite state machines and data paths can be synthesized by using RTL synthesis techniques. The primary refinement tasks are staying within the synthesizable subset and adding the implementation details and the hardware structure that were not included in the abstract model. You can reduce the refinement effort by ensuring that the system designer minimizes violations in the abstract model.

Verifying a refined SystemC design is faster than verifying a recoded HDL design, because refinement changes fewer lines of code and has fewer opportunities to introduce interpretation mistakes. Therefore, you typically spend less time debugging and verifying the hardware design.

Design engineers can achieve greater productivity by refining a SystemC executable specification. Design teams can fully deploy the productivity of system-level design by using a SystemC synthesis tool that supports both behavioral and RTL styles. This designer productivity improvement can reduce time-to-market.

---

## **About This Manual**

As with VHDL and Verilog, SystemC has modeling rules and a synthesizable subset of those rules. This manual describes the modeling rules and synthesizable subset for describing RTL in SystemC.



# 2

## Creating SystemC Modules for RTL Synthesis

---

This chapter explains the SystemC and C/C++ language elements that are important for RTL synthesis. It contains the following sections:

- [Defining Modules and Processes](#)
- [Creating a Module](#)
- [Creating a Module With a Single SC\\_METHOD Process](#)
- [Creating a Module With Multiple SC\\_METHOD Processes](#)
- [Creating a Hierarchical RTL Module](#)

---

## Defining Modules and Processes

This modeling guide explains how to develop SystemC RTL modules for synthesis. It assumes that you are knowledgeable about the C/C++ language and the SystemC Class Library available from the Open SystemC Community Web site at <http://www.systemc.org>.

---

### Modules

The basic building block in SystemC is the module. A SystemC module is a container in which processes and other modules are instantiated. A typical module can have

- Single or multiple RTL processes to specify combinational or sequential logic
- Multiple RTL modules to specify hierarchy
- One or more member functions that are called from within an instantiated process or module

[Figure 2-1](#) shows a module with several RTL processes. The processes within a module are concurrent, and they execute whenever one of their sensitive inputs changes.

Figure 2-1 Module

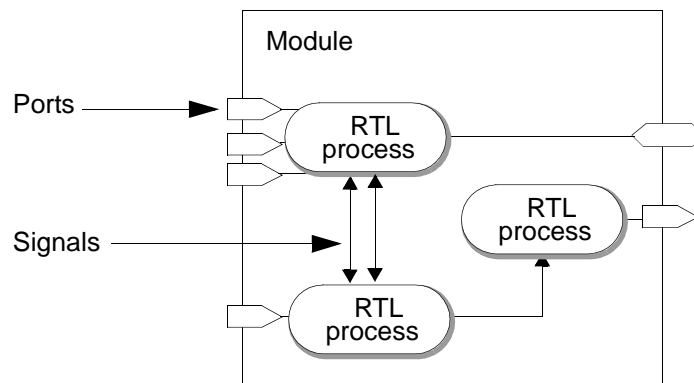

---

## Processes

SystemC provides processes to describe the parallel behavior of hardware systems. This means processes execute concurrently rather than sequentially like C++ functions. The code within a process, however, executes sequentially.

## Registering a Process

Defining a process is similar to defining a C++ function. A process is declared as a member function of a module class and registered as a process in the module's constructor. Registering a process means that it is recognized as a SystemC process rather than as an ordinary member function.

You can register multiple different processes, but it is an error to register more than one instance of the same process. To create multiple instances of the same process, enclose the process in a module and instantiate the module multiple times.

## Triggering Execution of a Process

You define a sensitivity list that identifies which input ports and signals trigger execution of the code within a process. You can define level-sensitive inputs to specify combinational logic or edge-sensitive inputs to specify sequential logic.

## Reading and Writing Processes

A process can read from and write to ports, internal signals, and internal variables.

Processes use signals to communicate with each other. One process can cause another process to execute by assigning a new value to a signal that interconnects them. Do not use data variables for communication between processes, because the processes execute in random order and it can cause nondeterminism (order dependencies) during simulation.

## Types of Processes

SystemC provides three process types—`SC_METHOD`, `SC_CTHREAD`, and `SC_THREAD`—that execute whenever their sensitive inputs change. For simulation, you can use any of the process types. For RTL synthesis, you can use only the `SC_METHOD` process.

The `SC_METHOD` process is sensitive to either changes in signal values (level-sensitive) or to particular transitions (edges) of the signal (edge-sensitive) and executes when one of its sensitive inputs changes.



---

## Creating a Module

It is a recommended coding practice to describe a module by using a separate header file (*module\_name.h*) and an implementation file (*module\_name.cpp* or *module\_name.cc*).

---

### Module Header File

Each module header file contains

- Port declarations
- Internal signal variable declarations
- Internal data variable declarations
- Process declarations
- Member function declarations
- Module constructor

## Module Syntax

Declare a module, using the syntax shown in bold in the following example:

```
#include "systemc.h"
SC_MODULE (module_name) {
    //Module port declarations
    //Signal variable declarations
    //Data variable declarations
    //Member function declarations
    //Method process declarations

    //Module constructor
    SC_CTOR (module_name) {
        //Register processes
        //Declare sensitivity list
    }
};
```

SC\_MODULE and SC\_CTOR are C++ macros defined in the SystemC Class library.

---

## Module Ports

Each module has any number of input, outputs, and inout ports (see [Figure 2-2](#)), which determine the direction of data into or out of the module.

Figure 2-2 Module Ports

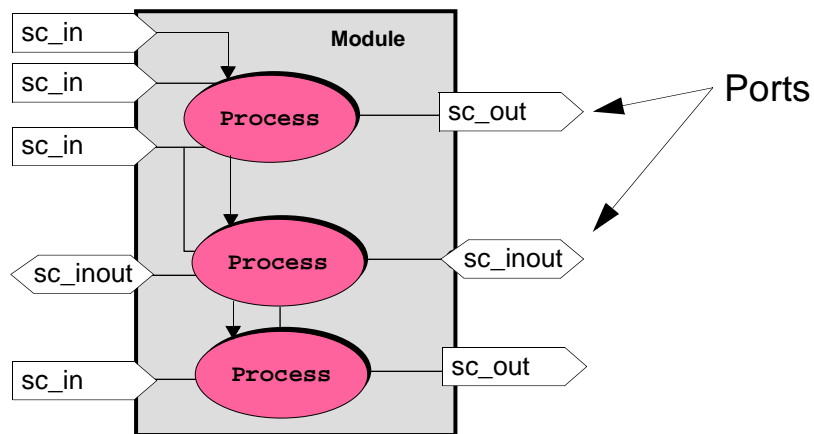

A port is a data member of `SC_MODULE`. You can declare any number of `sc_in`, `sc_out`, and `sc_inout` ports. To read from an output port, declare it as an `sc_inout` rather than an `sc_out` port.

## Port Syntax

Declare ports by using the syntax shown in bold in the following example:

```
SC_MODULE (module_name) {  
    //Module port declarations  
    sc_in<port_data_type> port_name;  
    sc_out<port_data_type> port_name;  
    sc_inout<port_data_type> port_name;  
    sc_in<port_data_type> port_name;  
  
    //Module constructor  
    SC_CTOR (module_name) {  
        //Register processes  
        //Declare sensitivity list  
    }  
};
```

## Port Data Types

Ports connect to signals and have a data type associated with them. For synthesis, declare each port as one of the synthesizable data types described in [“Converting to a Synthesizable Subset”](#) on page 3-2.

---

## Signals

Modules use ports to communicate with other modules. In hierarchical modules, use signals to communicate between the ports of instantiated modules. Use internal signals for peer-to-peer communication between processes within the same module, as shown in [Figure 2-3](#).

*Figure 2-3 Processes and Signals*

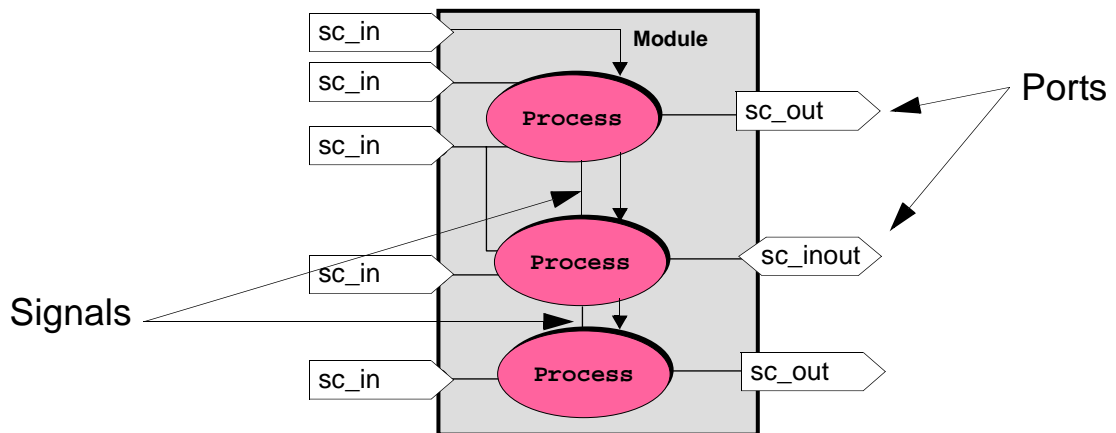

## Signal Syntax

Declare signals by using the syntax shown in bold in the following example:

```
SC_MODULE (module_name) {
    //Module port declarations
    sc_in<port_type> port_name;
    sc_out<port_type> port_name;
    sc_in<port_type>port_name;

    //Internal signal variable declarations
    sc_signal<signal_type> signal_name;
    sc_signal<signal_type> signal1, signal2;

    //Data variable declarations
    //Process declarations
    //Member function declarations

    //Module constructor
    SC_CTOR (module_name) {
        //Register processes
        //Declare sensitivity list
    }
};
```

## Signal Data Types

A signal's bit-width is determined by its corresponding data type. Specify the data type as any of the synthesizable SystemC or C++ data types listed in [“Converting to a Synthesizable Subset” on page 3-2](#). Signals and the ports they connect must have the same data types.

---

## Data Member Variables

Inside a module, you can define data member variables of any synthesizable SystemC or C++ type. These variables can be used for internal storage in the module. Recommendations about using data member variables for synthesis are provided in [“Data Members of a Module” on page 3-14](#). Declare internal data variables by using the syntax shown in bold in the following example:

```
SC_MODULE (module_name) {
    //Module port declarations
    sc_in<port_type> port_name;
    sc_out<port_type> port_name;
    sc_in port_name;

    //Internal signal variable declarations
    sc_signal<signal_type> signal_name;

    //Data member variable declarations
    int count_val;           //Internal counter
    sc_int<8> mem[1024];    //Array of sc_int

    //Process declarations
    //Member function declaration

    //Module constructor
    SC_CTOR (module_name) {
        //Register processes
        //Declare sensitivity list
    }
};
```

### Note:

Do not use data variables for peer-to-peer communication in a module. This can cause pre- and post-synthesis simulation mismatches and nondeterminism (order dependency) in your design.

---

## Creating a Process in a Module

SystemC processes are declared in the module body and registered as processes inside the constructor of the module, as shown in bold in [Example 2-1](#).

You must declare a process with a return type of void and no arguments, which is also shown in bold in [Example 2-1](#).

To register a function as an SC\_METHOD process, you need to use the SC\_METHOD macro that is defined in the SystemC class library. The SC\_METHOD macro takes one argument, the name of the process.

### *Example 2-1 Creating a Method Process in a Module*

```
SC_MODULE(my_module) {
    // Ports
    sc_in<int> a;
    sc_in<bool> b;
    sc_out<int> x;
    sc_out<int> y;
    // Internal signals
    sc_signal<bool> c;
    sc_signal<int> d;
    // process declaration
    void my_method_proc();
    // module constructor
    SC_CTOR(my_module) {
        // register process
        SC_METHOD(my_method_proc);
        // Define the sensitivity list
    }
};
```

---

## Defining the Sensitivity List

An SC\_METHOD process reacts to a set of signals called its sensitivity list. You can use the sensitive(), sensitive\_pos(), or sensitive\_neg() functions or the sensitive, sensitive\_pos, or sensitive\_neg streams in the sensitivity declaration list.

## Defining a Level-Sensitive Process

For combinational logic, define a sensitivity list that includes all input ports, inout ports, and signals used as inputs to the process. Use the sensitive method to define the level-sensitive inputs. [Example 2-2](#) shows in bold a stream-type declaration and a function-type declaration. Specify any number of sensitive inputs for the stream-type declaration, and specify only one sensitive input for the function-type declaration. You can call the sensitive function multiple times with different inputs.

### *Example 2-2 Defining a Level-Sensitive Sensitivity List*

```
SC_MODULE(my_module) {
    // Ports
    sc_in<int> a;
    sc_in<bool> b;
    sc_out<int> x;
    sc_out<int> y;
    // Internal signals
    sc_signal<bool> c;
    sc_signal<int> d;
    sc_signal<int> e;
    // process declaration
    void my_method_proc();
    // module constructor
    SC_CTOR(my_module) {
        // register process
        SC_METHOD(my_method_proc);
        // declare level-sensitive sensitivity list
        sensitive << a << c << d; // Stream declaration
    }
}
```



```

        sensitive(b); //Function declaration
        sensitive(e); //Function declaration
    }
};

```

## Incomplete Sensitivity Lists

To eliminate the risk of pre- and post-synthesis simulation mismatches, include all the inputs to the combinational logic process in the sensitivity list of the method process. [Example 2-3](#) shows an incomplete sensitivity list.

### *Example 2-3 Incomplete Sensitivity List*

```

//method process
void comb_proc () {
    out_x = in_a & in_b & in_c;
}

SC_CTOR( comb_logic_complete ) {
    // Register method process
    SC_METHOD( comb_proc);
    sensitive << in_a << in_b; // missing in_c
}

```

## Defining an Edge-Sensitive Process

For sequential logic, define a sensitivity list of the input ports and signals that trigger the process. Use the `sensitive_pos`, `sensitive_neg`, or both the `sensitive_pos` and `sensitive_neg` methods to define the edge-sensitive inputs that trigger the process. Declare ports and the edge-sensitive inputs as type `sc_in<bool>`. You can define any number of `sc_in<bool>` inputs.

Define the sensitivity list by using either the function or the stream syntax. [Example 2-4](#) shows in bold an example of a stream-type declaration for two inputs and a function-type declaration for the clock input.

#### *Example 2-4 Defining an Edge-Sensitive Sensitivity List*

```
SC_MODULE(my_module) {
    // Ports
    sc_in<int> a;
    sc_in<bool> b;
    sc_in<bool> clock;
    sc_out<int> x;
    sc_out<int> y;
    sc_in<bool> reset;
    // Internal signals
    sc_signal<bool> c;
    sc_signal<int> d;
    // process declaration
    void my_method_proc();
    // module constructor
    SC_CTOR(my_module) {
        // register process
        SC_METHOD(my_method_proc);
        // declare sensitivity list
        sensitive_pos (clock); //Function delaration
        sensitive_neg << b << reset; // Stream declaration
    }
};
```

### **Limitations for Sensitivity Lists**

When you define a sensitivity list, adhere to the following limitations:

- You cannot specify both edge-sensitive and level-sensitive inputs in the same process for synthesis.
- You cannot declare an `sc_logic` type for the clock or other edge-sensitive inputs. You can declare only an `sc_in<bool>` data type.

---

## Member Functions

You can declare member functions in a module that are not processes. This type of member function is not registered as a process in the module's constructor. It can be called from a process. Member functions can contain any synthesizable C++ or SystemC statement allowed in a SC\_METHOD process.

A member function that is not a process can return any synthesizable data type.

---

## Module Constructor

For each module you need to create a constructor, which is used to

- Register processes
- Define a sensitivity list for an SC\_METHOD process

For synthesis, other statements are not allowed in the constructor. See [Example 2-4](#).

---

## Implementing the Module

In the module implementation file, define the functionality of each SC\_METHOD process and member function. [Example 2-5](#) shows a minimal implementation file.

### *Example 2-5 Module Implementation File*

```
#include "systemc.h"
#include "my_module.h"
void my_module::my_method_proc() {
    // describe process functionality as C++ code
}
```

---

## Reading and Writing Ports and Signals

In the module implementation description, you can read from or write to a port or signal by using the read and write methods or by assignment.

When you read or write a port, as a recommended coding practice, use the read() and write() methods. Use the assignment operator for variables. [Example 2-6](#) shows in bold how to use the read and write methods for ports and signals, and it shows assignment operators for variables.

### *Example 2-6 Using Assignment and read() and write() Methods*

```
//...
// read method
address = into.read();           // get address
// assignment
temp1 = address;                 // save address
data_tmp = memory[address]; // get data from memory
// write method
outof.write(data_tmp);         // write out
// assignment
temp2 = data_tmp;               // save data_tmp
//...
```

---

## Reading and Writing Bits of Ports and Signals

You read or write all bits of a port or signal. You cannot read or write the individual bits, regardless of the type. To do a bit-select on a port or signal, read the value into a temporary variable and do a bit-select on the temporary variable. [Example 2-7](#) shows in bold how to write a bit by using a temporary variable.

### Example 2-7 Reading and Writing Bits of a Variable

```
//...
sc_signal <sc_int<8> > a;
sc_int<8> b;
bool c;
b = a.read();
c = b[0];

// c = a[0]; /Does not work in SystemC
```

[Example 2-7](#) reads the value of signal `a` into temporary variable `b`, and bit 0 of `b` is assigned to `c`. You cannot read a bit from signal `a`, because this operation is not allowed in SystemC.

---

## Signal and Port Assignments

When you assign a value to a signal or port, the value on the right side is not transferred to the left side until the process ends. This means the signal value as seen by other processes is not updated immediately, but it is deferred.

[Example 2-8](#) shows a serial register implementation with signal assignment, and [Figure 2-4](#) shows the resulting schematic.

### Example 2-8 Signal Assignment

```
#include "systemc.h"

SC_MODULE(rtl_nb) {
    sc_in<bool> clk;
    sc_in<bool> data;
    sc_inout<bool> regc, regd;

    void reg_proc() {
        regc.write(data.read());
        regd.write(regc.read());
    }
}
```

```

SC_CTOR(rtl_nb) {
    SC_METHOD(reg_proc);
    sensitive_pos << clk;
}
};

```

Figure 2-4 Signal Assignment Schematic

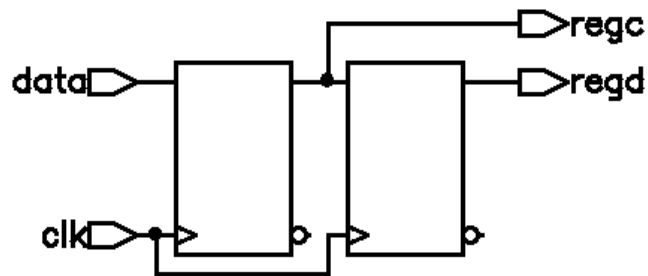

---

## Variable Assignment

When you assign a value to a variable, the value on the right side is immediately transferred to the left side of the assignment statement.

[Example 2-9](#) uses a variable assignment, where the implementation assigns the value of `data` to `rega` and `regb`, as the resulting schematic in [Figure 2-5](#) indicates.

### Note:

This example is only an illustration of variable assignment. You can write the same behavior more efficiently by removing the `rega_v` and `regb_v` variables and writing the ports directly.

### Example 2-9 Variable Assignment

```
#include "systemc.h"

SC_MODULE(rtl_b) {
    sc_in<bool> clk;
    sc_in<bool> data;
    sc_out<bool> rega, regb;

    bool rega_v, regb_v;

    void reg_proc() {
        rega_v = data.read();
        regb_v = rega_v;
        rega.write(rega_v);
        regb.write(regb_v);
    }

    SC_CTOR(rtl_b) {
        SC_METHOD(reg_proc);
        sensitive_pos << clk;
    }
};
```

Figure 2-5 Variable Assignment Schematic

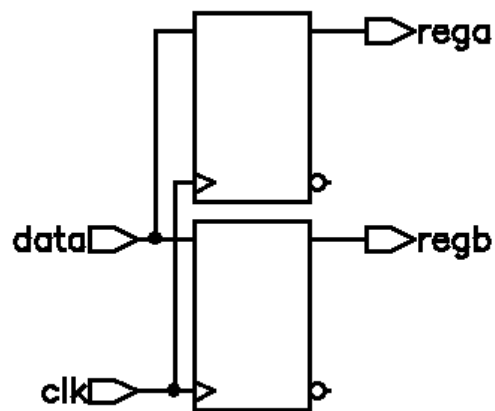

---

## Creating a Module With a Single SC\_METHOD Process

[Example 2-10](#) is a complete example of an RTL description of a count zeros circuit that contains one SC\_METHOD process, `control_proc()`, and two member functions, `legal()` and `zeros()`. The circuit determines in one cycle if an 8-bit value on the input port is valid (no more than one sequence of zeros) and how many zeros the value contains. The circuit produces two outputs, the number of zeros found and an error indication. [Figure 2-6](#) illustrates the module and its ports.

*Figure 2-6 Count Zeros Combinational Module*

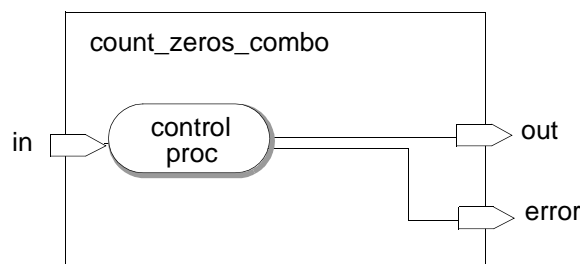

### *Example 2-10 Count Zeros Combinational Version*

```
/****count_zeros_comb.h file***/  
#include "systemc.h"  
  
SC_MODULE(count_zeros_comb) {  
    sc_in<sc_uint<8> > in;  
    sc_out<sc_uint<4> > out;  
    sc_out<bool> error;  
  
    bool legal(sc_uint<8> x);  
    sc_uint<4> zeros(sc_uint<8> x);  
    void control_proc();  
  
    SC_CTOR(count_zeros_comb) {  
        SC_METHOD(control_proc);  
        sensitive << in;  
    }  
};
```



```

/****count_zeros_comb.cpp file****/
#include "count_zeros_comb.h"

void count_zeros_comb::control_proc() {
    sc_uint<4> tmp_out;
    bool is_legal = legal(in.read());
    error.write(! is_legal);
    is_legal ? tmp_out = zeros(in.read()) : tmp_out = 0;
    out.write(tmp_out);
}

bool count_zeros_comb::legal(sc_uint<8> x) {
    bool is_legal = 1;
    bool seenZero = 0;
    bool seenTrailing = 0;
    for (int i=0; i <=7; ++i) {
        if (seenTrailing && (x[i] == 0)) {
            is_legal = 0;
            break;
        } else if (seenZero && (x[i] == 1)) {
            seenTrailing = 1;
        } else if (x[i] == 0) {
            seenZero = 1;
        }
    }
    return is_legal;
}

sc_uint<4> count_zeros_comb::zeros(sc_uint<8> x) {
    int count = 0;
    for (int i=0; i <= 7; ++i) {
        if (x[i] == 0)
            ++count;
    }
    return count;
}

```

## Creating a Module With Multiple SC\_METHOD Processes

Example 2-11 on page 2-23 shows a sequential description of the same count zeros circuit described in “Creating a Module With a Single SC\_METHOD Process” on page 2-20.

In this sequential version, there are three SC\_METHOD processes and several signals for communication between the processes, as shown in Figure 2-7. The comb\_logic( ) and output\_assign( ) processes are level-sensitive, and the seq\_logic( ) process is sensitive to the positive edge of the clk and reset inputs. The set\_defaults( ) member function is called at the beginning of the comb\_logic( ) process.

This example does not show typical simulation-specific code that you might include for debugging purposes.

Figure 2-7 Count Zeros Sequential Module

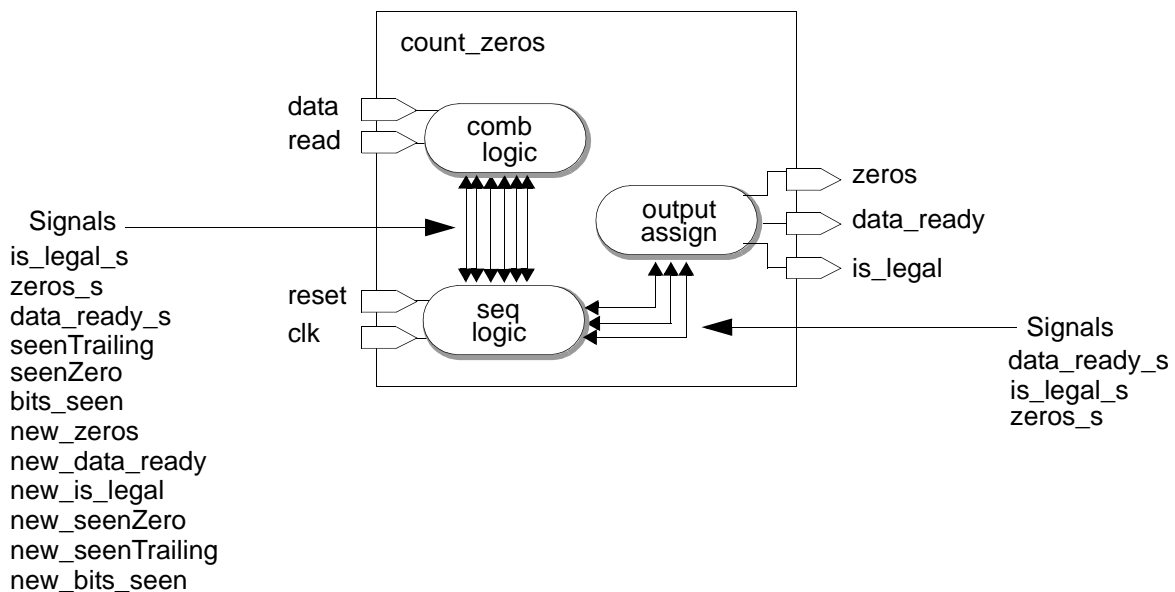

## Example 2-11 Count Zeros Sequential Version

```
/****count_zeros_seq.h file****/
#include "systemc.h"

#define ZEROS_WIDTH 4
#define MAX_BIT_READ 7

SC_MODULE(count_zeros_seq) {
    sc_in<bool> data, reset, read, clk;
    sc_out<bool> is_legal, data_ready;
    sc_out<sc_uint<ZEROS_WIDTH> > zeros;

    sc_signal<bool> new_data_ready, new_is_legal, new_seenZero, new_seenTrailing;
    sc_signal<bool> seenZero, seenTrailing;
    sc_signal<bool> is_legal_s, data_ready_s;
    sc_signal<sc_uint<ZEROS_WIDTH> > new_zeros, zeros_s;
    sc_signal<sc_uint<ZEROS_WIDTH - 1> > bits_seen, new_bits_seen;

    // Processes
    void comb_logic();
    void seq_logic();
    void assign_outputs();

    // Helper functions
    void set_defaults();

    SC_CTOR(count_zeros_seq) {
        SC_METHOD(comb_logic);
        sensitive << data << read << is_legal_s << data_ready_s;
        sensitive << seenTrailing << seenZero << zeros_s << bits_seen;

        SC_METHOD(seq_logic);
        sensitive_pos << clk << reset;

        SC_METHOD(assign_outputs);
        sensitive << is_legal_s << data_ready_s << zeros_s;
    }
};
```

```

/****count_zeros_seq.cpp file****/
#include "count_zeros_seq.h"

/*
 * SC_METHOD: comb_logic()
 * finds a singular run of zeros and counts them
 */
void count_zeros_seq::comb_logic() {
    set_defaults();
    if (read.read()) {
        if (seenTrailing && (data.read() == 0)) {
            new_is_legal = false;
            new_zeros = 0;
            new_data_ready = true;
        } else if (seenZero && (data.read() == 1)) {
            new_seenTrailing = true;
        } else if (data.read() == 0) {
            new_seenZero = true;
            new_zeros = zeros_s.read() + 1;
        }
    }

    if (bits_seen.read() == MAX_BIT_READ)
        new_data_ready = true;
    else
        new_bits_seen = bits_seen.read() + 1;
}

/*
 * SC_METHOD: seq_logic()
 * All registers have asynchronous resets
 */
void count_zeros_seq::seq_logic() {
    if (reset) {
        zeros_s = 0;
        bits_seen = 0;
        seenZero = false;
        seenTrailing = false;
        is_legal_s = true;
        data_ready_s = false;
    } else {
        zeros_s = new_zeros;
        bits_seen = new_bits_seen;
        seenZero = new_seenZero;
        seenTrailing = new_seenTrailing;
        is_legal_s = new_is_legal;
        data_ready_s = new_data_ready;
    }
}

```

```

    }
}

/*
 * SC_METHOD: assign_outputs()
 * Zero time assignments of signals to their associated outputs
 */
void count_zeros_seq::assign_outputs() {
    zeros = zeros_s;
    is_legal = is_legal_s;
    data_ready = data_ready_s;
}

/*
 * method: set_defaults()
 * sets the default values of the new_* signals for the comb_logic
 * process.
 */
void count_zeros_seq::set_defaults() {
    new_is_legal = is_legal_s;
    new_seenZero = seenZero;
    new_seenTrailing = seenTrailing;
    new_zeros = zeros_s;
    new_bits_seen = bits_seen;
    new_data_ready = data_ready_s;
}

```

---

## Creating a Hierarchical RTL Module

You can create a hierarchical module with multiple instantiated modules.

---

### The Basics of Hierarchical Module Creation

To create a hierarchical module,

1. Create data members in the top-level module that are pointers to the instantiated modules.
2. Allocate the instantiated modules inside the constructor of the top-level module, giving each instance a unique name.
3. Bind the ports of the instantiated modules to the ports or signals of the top-level module. Use either binding by position or binding by name coding style, which is illustrated in bold in [Example 2-12](#).

[Example 2-12](#) shows the partial source code of two modules, `fir_fsm` and `fir_data`, instantiated within the `fir_top` module. The relevant code is highlighted in bold.

#### *Example 2-12 Hierarchical Module With Multiple RTL Modules*

```
/**firtop.h***/
#include <systemc.h>
#include "fir_fsm.h"
#include "fir_data.h"

SC_MODULE(fir_top) {

    sc_in_clk          CLK;
    sc_in<bool>        RESET;
    sc_in<bool>        IN_VALID;
    sc_in<int>         SAMPLE;
```

```

sc_out<bool>          OUTPUT_DATA_READY;
sc_out<int>           RESULT;

sc_signal<unsigned> state_out; //Communication between
                               //two peer modules

// Create data members - pointers to instantiated
// modules
fir_fsm *fir_fsm1;
fir_data *fir_data1;
SC_CTOR(fir_top) {
    // Create new instance of fir_fsm module
    fir_fsm1 = new fir_fsm("FirFSM");

    // Binding by name
    fir_fsm1->clock(CLK);
    fir_fsm1->reset(RESET);
    fir_fsm1->in_valid(IN_VALID);
    fir_fsm1->state_out(state_out);

    // Binding by position alternative
    // fir_fsm1 (CLK, RESET, IN_VALID, state_out);

    // Create new instance
    // of fir_data module and bind by name
    fir_data1 = new fir_data("FirData");
    fir_data1->reset(RESET);
    fir_data1->state_out(state_out);
    fir_data1->sample(SAMPLE);
    fir_data1->result(RESULT);
    fir_data1->output_data_ready(OUTPUT_DATA_READY);
    fir_data1->clk(CLK);
    ...
}
};

/****fir_fsm.h****/
SC_MODULE(fir_fsm) {

    sc_in<bool>      clock;
    sc_in<bool>      reset;
    sc_in<bool>      in_valid;

```

```

    sc_out<unsigned> state_out;
    ...

/****fir_data.h****/
SC_MODULE(fir_data) {

    sc_in<bool>      clk;
    sc_in<bool>      reset;
    sc_in<unsigned>  state_out;
    sc_in<int>       sample;
    sc_out<int>      result;
    sc_out<bool>     output_data_ready;
    ...
}

```

---

## Hierarchical RTL Module Example

[Example 2-13 on page 2-29](#) shows a complete example of the hierarchical RTL finite impulse response (FIR) filter description. This is a typical sequential logic description that separates the controlling FSM ([Example 2-14 on page 2-30](#)) and the data path ([Example 2-15 on page 2-32](#)) into two separate modules. [Figure 2-8](#) illustrates the modules, the port binding, and their interconnecting signals.

In the top-level `fir_rtl` module, data member pointers to the `fir_fsm` and `fir_data` modules are declared, new instances of the two modules (`fir_fsm1` and `fir_data1`) are created, and the port bindings are defined. A signal, `state_out`, is defined to connect the `fir_fsm1` and `fir_data1` `state_out` ports.

Coding guidelines for state machines are described in [“State Machines” on page 4-37](#).



Figure 2-8 FIR RTL Modules

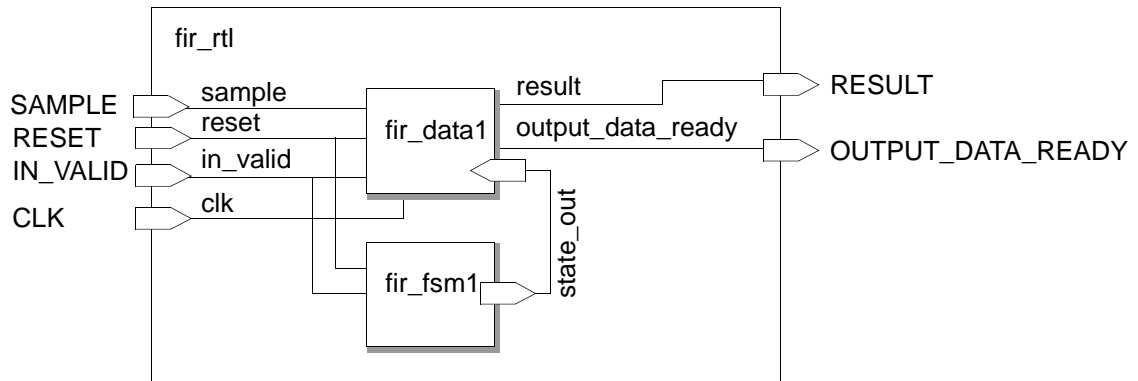

Example 2-13 FIR Top-Level Module

```

/****fir_rtl.h file****/
#include <systemc.h>
#include "fir_fsm.h"
#include "fir_data.h"

SC_MODULE(fir_rtl) {

    sc_in<bool>      clk;
    sc_in<bool>      reset;
    sc_in<bool>      in_valid;
    sc_in<int>       sample;
    sc_out<bool>     output_data_ready;
    sc_out<int>      result;

    sc_signal<unsigned> state_out;

    fir_fsm  *fir_fsm1;
    fir_data *fir_data1;

    SC_CTOR(fir_rtl) {

        fir_fsm1 = new fir_fsm("FirFSM");
        fir_fsm1->clock(clk);
        fir_fsm1->reset(reset);
    }
}

```

```

        fir_fsm1->in_valid(in_valid);
        fir_fsm1->state_out(state_out);

        fir_data1 = new fir_data("FirData");
        fir_data1->state_out(state_out);
        fir_data1->sample(sample);
        fir_data1->clock(clk);
        fir_data1->result(result);
        fir_data1->output_data_ready(output_data_ready);
    }
};

```

### Example 2-14 FIR FSM Module

```

/****fir_fsm.h file****/

SC_MODULE(fir_fsm) {

    sc_in<bool>      clock;
    sc_in<bool>      reset;
    sc_in<bool>      in_valid;
    sc_out<unsigned> state_out;

    // defining the states of the ste machine
    enum {reset_s, first_s, second_s, third_s, output_s,
wait_s} state;

    SC_CTOR(fir_fsm)
    {
        SC_METHOD(entry);
        sensitive_pos(clock);
    };
    void entry();
};

/****fir_fsm.cpp file****/
#include <systemc.h>
#include "fir_fsm.h"

```

```

void fir_fsm::entry() {

    sc_uint<3> state_tmp;

    // reset behavior
    if(reset.read()==true) {
        state = reset_s;
    }
    // main state machine
    switch(state) {
    case reset_s:
        state = wait_s;
        state_tmp = 0;
        state_out.write(state_tmp);
        break;
    case first_s:
        state = second_s;
        state_tmp = 1;
        state_out.write(state_tmp);
        break;
    case second_s:
        state = third_s;
        state_tmp = 2;
        state_out.write(state_tmp);
        break;
    case third_s:
        state = output_s;
        state_tmp = 3;
        state_out.write(state_tmp);
        break;
    case output_s:
        state = wait_s;
        state_tmp = 4;
        state_out.write(state_tmp);
        break;

    default:
        if(in_valid.read()==true) {
            state = first_s;
        };
        state_tmp = 5;
        state_out.write(state_tmp);
    }
}

```

```

        break;
    }
}

```

### Example 2-15 FIR Data Module

```

/****fir_data.h file****/

SC_MODULE(fir_data) {

    sc_in<unsigned>  state_out;
    sc_in<int>       sample;
    sc_out<int>     result;
    sc_out<bool>    output_data_ready;
    sc_in<bool>     clock;

    sc_int<19> acc;
    sc_int<8>  shift[16];
    sc_int<9>  coefs[16];

    SC_CTOR(fir_data)
    {
        SC_METHOD(entry);
        sensitive_pos(clock);
    };
    void entry();
};

/****fir_data.cpp file****/

#include <systemc.h>
#include "fir_data.h"

void fir_data::entry()
{
    #include "fir_const_rtl.h"
    sc_int<8> sample_tmp;

    sc_uint<3> state = state_out.read();
}

```

```

switch (state) {
case 0:
    sample_tmp    = 0;
    acc = 0;
    for (int i=0; i<=15; i++) {
        shift[i] = 0;}
    result.write(0);
    output_data_ready.write(false);
    break;
case 1 :
    sample_tmp = sample.read();
    acc = sample_tmp*coefs[0];
    acc += shift[14]* coefs[15];
    acc += shift[13]*coefs[14];
    acc += shift[12]*coefs[13];
    acc += shift[11]*coefs[12];
    output_data_ready.write(false);
    break;
case 2 :
    acc += shift[10]*coefs[11];
    acc += shift[9]*coefs[10];
    acc += shift[8]*coefs[9];
    acc += shift[7]*coefs[8];
    output_data_ready.write(false);
    break;
case 3 :
    acc += shift[6]*coefs[7];
    acc += shift[5]*coefs[6];
    acc += shift[4]*coefs[5];
    acc += shift[3]*coefs[4];
    output_data_ready.write(false);
    break;
case 4 :
    acc += shift[2]*coefs[3];
    acc += shift[1]*coefs[2];
    acc += shift[0]*coefs[1];
    for(int i=14; i>=0; i--) {
        shift[i+1] = shift[i];
    };
    shift[0] = sample.read();
    result.write(acc);

```

```
        output_data_ready.write(true);
        break;
    case 5 :
        // This state waits for valid input
        output_data_ready.write(false);
        break;
    default :
        output_data_ready.write(false);
        result.write(0);
    }
}
```

# 3

## Using the Synthesizable Subset

---

This chapter explains the subset of the SystemC and C/C++ language elements and data types that are used for RTL synthesis. It contains the following sections:

- [Converting to a Synthesizable Subset](#)
- [Refining Data](#)
- [Recommendations About Refinement for Synthesis](#)

---

## Converting to a Synthesizable Subset

To prepare for synthesis, you need to convert all nonsynthesizable code into synthesizable code. This is required only for functionality that is to be synthesized.

Although you can use any SystemC class or C++ construct for simulation and other stages of the design process, only a subset of the language can be used for synthesis. You can use `#ifdef` and `#endif` to comment out code that is needed only for simulation. For example, you can exclude trace and print statements with these compiler directives.

---

### SystemC and C++ Synthesizable Subsets

The synthesizable subsets of SystemC and C++ are provided in the sections that follow. Wherever possible, a recommended corrective action is indicated for converting nonsynthesizable constructs into synthesizable constructs. For many nonsynthesizable constructs, there is no obvious recommendation for converting them into synthesizable constructs or there are numerous ways to convert them. In such cases, a recommended corrective action is not indicated. Familiarize yourself with the synthesizable subset and use it as much as possible in your pure C/C++ or high-level SystemC models to minimize the refinement effort for synthesis.

You can use any SystemC or C++ construct for a testbench. You do not need to restrict your code to the synthesizable subset in the testbench.



## Nonsynthesizable SystemC Constructs

The SystemC constructs listed in [Table 3-1](#) are not supported for RTL synthesis.

*Table 3-1 Nonsynthesizable SystemC Constructs for RTL Synthesis*

Category	Construct	Comment	Corrective action
Thread process	SC_THREAD	Used for modeling a testbench but not supported for synthesis.	
CTHREAD process	SC_CTHREAD	Used for simulation and modeling at the behavioral level.	
Main function	sc_main()	Used for simulation.	
Clock generators	sc_start()	Used for simulation.	Use only in sc_main( ).
Global watching	watching()	Not supported for RTL synthesis	
Local watching	W_BEGIN, W_END, W_DO, W_ESCAPE	Not supported.	
Tracing	sc_trace, sc_create* trace_file	Creates waveforms of signals, channels, and variables for simulation.	Comment out for synthesis.

## Nonsynthesizable C/C++ Constructs

The C and C++ constructs listed in [Table 3-2](#) are not supported for RTL synthesis.

*Table 3-2 Nonsynthesizable C/C++ Constructs*

Category	Construct	Comment	Corrective action
Local class declaration		Not allowed.	Replace.
Nested class declaration		Not allowed.	Replace.
Derived class		Only SystemC modules and processes supported.	Replace.
Dynamic storage allocation	malloc(), free(), new, new[], delete[], delete[]	malloc(), free(), new, new[], delete, and delete[] are not supported.	Use static memory allocation.
Exception handling	try, catch, throw	Not allowed.	Comment out.
Recursive function call		Not allowed.	Replace with iteration.
Function overloading		Not allowed (except the classes overloaded by SystemC).	Replace with unique function calls.
C++ built-in functions		Math library, I/O library, file I/O, and similar built-in C++ functions not allowed.	Replace with synthesizable functions or remove.
Virtual function		Not allowed.	Replace with a nonvirtual function.
Inheritance		Not allowed.	Create an independent SC_MODULE.
Multiple inheritance		Not allowed.	Create independent modules.

*Table 3-2 Nonsynthesizable C/C++ Constructs (Continued)*

Category	Construct	Comment	Corrective action
Member access control specifiers	public, protected, private, friend	Allowed in code but ignored for synthesis. All member access is public.	
Accessing struct members with the (->) operator	-> operator	Not allowed, except for module instantiation.	Replace with access using the period (.) operator.
Static member		Not allowed.	Replace with nonstatic member variable.
Dereference operator	* and & operators	Not allowed.	Replace dereferencing with array accessing.
for loop comma operator	, operator	The comma operator is not allowed in a for loop definition.	Remove the comma operators.
Operator overloading		Not allowed (except the classes overloaded by SystemC).	Replace overloading with unique function calls.
Operator, sizeof	sizeof	Not allowed.	Determine size statically for use in synthesis.
Pointer	*	Pointers are allowed only in hierarchical modules to instantiate other modules.	Replace all other pointers with access to array elements or individual elements.
Pointer type conversions		Not allowed.	Do not use pointers. Use explicit variable reference.
this pointer	this	Not allowed.	Replace.
Reference, C++	&	Allowed only for passing parameters to functions.	Replace in all other cases.

*Table 3-2 Nonsynthesizable C/C++ Constructs (Continued)*

Category	Construct	Comment	Corrective action
Reference conversion		Reference conversion is supported for implicit conversion of signals only.	Replace in all other cases.
User-defined template class		Only SystemC templates classes such as <code>sc_int&lt;&gt;</code> are supported.	Replace.
Type casting at runtime		Not allowed.	Replace.
Type identification at runtime		Not allowed.	Replace.
Explicit user-defined type conversion		The C++ built-in types and SystemC types are supported for explicit conversion.	Replace in all other cases.
Unconditional branching	<code>goto</code>	Not allowed.	Replace.
Unions		Not allowed.	Replace with structs.
Global variable		Not supported for synthesis.	Replace with local variables.
Member variable		Member variables accessed by two or more <code>SC_METHOD</code> processes are not supported. However, access to member variables by only one process is supported.	Use signals instead of variables for communication between processes.
Volatile variable		Not allowed.	Use only nonvolatile variables.

---

## Refining Data

A pure C/C++ model or a high-level SystemC model typically uses native C++ types or aggregates (structures) of such types. Native C++ types such as `int`, `char`, `bool`, and `long` have fixed, platform-dependent widths, which are often not the correct width for efficient hardware. For example, you might need only a 6-bit integer for a particular operation, instead of the native C++ 32-bit integer. In addition, C++ does not support four-valued logic vectors, operations such as concatenation, and other features that are needed to efficiently describe hardware operations.

SystemC provides a set of limited-precision and arbitrary-precision data types that allows you to create integers, bit vectors, and logic vectors of any length. SystemC also supports all common operations on these data types.

To refine a SystemC model for RTL synthesis, you need to evaluate all variable declarations, formal parameters, and return types of all functions to determine the appropriate data type and the appropriate widths of each data type. Selecting the data widths is a design decision, and it is typically a tradeoff between the cost of hardware and the required precision. This decision is, therefore, left to you.

### Synthesizable Data Types

C++ is a strongly typed language. Every constant, port, signal, variable, function return type, and parameter is declared as a data type, such as `bool` or `sc_int<n>`, and can hold or return a value of that type. Therefore, it is important that you use the correct data types in expressions.

---

## Nonsynthesizable Data Types

All SystemC and C++ data types can be used for RTL synthesis, except the following types:

- Floating-point types such as float and double
- Fixed-point types `sc_fixed`, `sc_ufixed`, `sc_fix`, and `sc_ufix`
- Access types such as pointers
- File types such as `FILE`
- I/O streams such as `stdout` and `cout`

---

## Recommended Data Types for Synthesis

For best synthesis, use appropriate data types and bit-widths so unnecessary hardware is not built during RTL synthesis.

The following are some general recommendations about data type selections:

- For a single-bit variable, use the native C++ type `bool`.
- For variables with a width of 64 bits or less, use `sc_int` or `sc_uint` data types. Use `sc_uint` for all logic and unsigned arithmetic operations. Use `sc_int` for signed arithmetic operations as well as for logic operations. These types produce the fastest simulation runtimes of the SystemC types.
- For variables larger than 64 bits, use `sc_bigint` or `sc_biguint` if you want to do arithmetic operations with these variables.

- Use `sc_logic` or `sc_lv` only when you need to model three-state signals or buses. When you use these data types, avoid comparison with X and Z values in your synthesizable code, because such comparisons are not synthesizable.
- Use native C++ integer types for loop counters.
- Use the native C++ data types with caution, because their size is platform-dependent. For example, on most platforms, a `char` is 8 bits wide, a `short` is 16 bits wide, and both an `int` and `long` are 32 bits wide. An `int`, however, can be 16, 32, or 64 bits wide.

To restrict bit size for synthesis, use the recommended SystemC data types summarized in [Table 3-3](#) in place of the equivalent C++ native type. For example, change an `int` type to an `sc_int<n>` type.

*Table 3-3 Synthesizable Data Types*

SystemC and C++ type	Description
<code>sc_bit</code>	A single-bit true or false value. Supported but not recommended. Use the <code>bool</code> data type.
<code>sc_bv&lt;n&gt;</code>	Arbitrary-length bit vector. Use <code>sc_uint&lt;n&gt;</code> when possible.
<code>sc_logic</code>	A single-bit 0, 1, X, or Z.
<code>sc_lv&lt;n&gt;</code>	Arbitrary-length logic vector.
<code>sc_int&lt;n&gt;</code>	Fixed-precision integers restricted in size up to 64 bits and 64 bits of precision during operations.
<code>sc_uint&lt;n&gt;</code>	Fixed-precision integers restricted in size up to 64 bits and 64 bits of precision during operations, unsigned.
<code>sc_bigint&lt;n&gt;</code>	Arbitrary-precision integers recommended for sizes over 64 bits and unlimited precision.
<code>sc_biguint&lt;n&gt;</code>	Arbitrary-precision integers recommended for sizes over 64 bits and unlimited precision, unsigned.

*Table 3-3 Synthesizable Data Types (Continued)*

<b>SystemC and C++ type</b>	<b>Description</b>
bool	A single-bit true or false value.
int	A signed integer, typically 32 or 64 bits, depending on the platform.
unsigned int	An unsigned integer, typically 32 or 64 bits, depending on the platform.
long	A signed integer, typically 32 bits or longer, depending on the platform.
unsigned long	An unsigned integer, typically 32 bits or longer, depending on the platform.
char	8 bits, signed character, platform-dependent.
unsigned char	8 bits, unsigned character, platform-dependent.
short	A signed short integer, typically 16 bits, depending on the platform.
unsigned short	An unsigned short integer, typically 16 bits, depending on the platform.
struct	A user-defined aggregate of synthesizable data types.
enum	A user-defined enumerated data type associated with an integer constant.



---

## Using SystemC Data Types

Use the SystemC data type operators to access individual bits of a value.

## Bit Vector Data Type Operators

[Table 3-4](#) lists the operators available for the SystemC `sc_bv` data type.

*Table 3-4 SystemC Bit Vector Data Type Operators*

---

Operators
Bitwise &(and),  (or), ^(xor), and ~(not)
Bitwise <<(shift left) and >>(shift right)
Assignment =, &=,  =, and ^=
Equality ==, !=
Bit selection [x]
Part selection range (x-y)
Concatenation (x,y)
Reduction: <code>and_reduce( )</code> , <code>or_reduce( )</code> , and <code>xor_reduce( )</code>
Type conversion: <code>to_uint( )</code> and <code>to_int( )</code>

---

## Fixed and Arbitrary Precision Data Type Operators

[Table 3-5](#) lists the operators available for the SystemC `sc_int` and `sc_uint` fixed-precision and `sc_bigint` and `sc_bignint` arbitrary-precision integer data types.

*Table 3-5 SystemC Integer Data Type Operators*

Operators
Bitwise <code>&amp;</code> (and), <code> </code> (or), <code>^(xor)</code> , and <code>~</code> (not)
Bitwise <code>&lt;&lt;</code> (shift left) and <code>&gt;&gt;</code> (shift right)
Assignment <code>=</code> , <code>&amp;=</code> , <code> =</code> , <code>^=</code> , <code>+=</code> , <code>-=</code> , <code>*=</code> , <code>/=</code> , and <code>%=</code>
Equality <code>==</code> , <code>!=</code>
Relational <code>&lt;</code> , <code>&lt;=</code> , <code>&gt;</code> , and <code>&gt;=</code>
Autoincrement <code>++</code> and autodecrement <code>--</code>
Bit selection <code>[x]</code>
Part selection range <code>(x-y)</code>
Concatenation <code>(x,y)</code>
Type conversion: <code>to_uint( )</code> and <code>to_int( )</code>

### Note:

The reduction `and_reduce()`, `or_reduce()`, and `xor_reduce()` operators are not supported for the fixed- and arbitrary-precision data types.

---

## Using Enumerated Data Types

Systemc supports enumerated (enum) data types and interprets an enum data type the same way a C++ compiler interprets it.

[Example 3-1](#) shows an enum definition.

### *Example 3-1 Enumerated Data Type*

```
enum command_t {
    NONE,
    RED,
    GREEN,
    YELLOW
};
```

---

## Using Aggregate Data Types

To group data types into a convenient aggregate type, define them as a struct type similar to [Example 3-2](#). You need to use all synthesizable data types in a struct for the struct to be synthesizable.

### *Example 3-2 Aggregate Data Type*

```
struct package {
    sc_uint<8> command;
    sc_uint<8> address;
    sc_uint<12> data;
}
```

---

## Using C++ Data Types

The native C++ data types, such as bool, char, int, long, short, unsigned char, unsigned int, unsigned long, and unsigned short, have a platform-specific size, which will be used during synthesis.

---

## Data Members of a Module

Do not use data members for interprocess communication, because it can lead to nondeterminism (order dependencies) during simulation and it can cause mismatches between the results of pre- and post-synthesis simulation. Instead of a data member for interprocess communication, use an `sc_signal` for this purpose.

[Example 3-3](#) shows (in bold) a data member variable named `count` that is incorrectly used to communicate between the `do_count()` and `outregs()` processes. A value is written to the `count` variable in the `do_count()` process, and a value is read from the same variable in the `outregs()` process. The order in which the two processes execute cannot be predicted—therefore, you cannot determine whether writing to the `count` variable is happening before or after `count` is incremented.

### *Example 3-3 Incorrect Use of a Data Member Variable for Interprocess Communication*

```
/**mem_var_bad.h***/
#include "systemc.h"

SC_MODULE(counter) {
    sc_in<bool> clk;
    sc_in<bool> reset_z;
    sc_out<sc_uint<4> > count_out;
    sc_uint<4> count;           // Member Variable
    SC_CTOR(counter) {
        SC_METHOD(do_count);
        sensitive_pos << clk;
        sensitive_neg << reset_z;

        SC_METHOD(outregs);
        sensitive_pos << clk;
        sensitive_neg << reset_z;
    }
}
```

```

void do_count() {
    if (reset.read() == 0)

        count = 0;
    else
        count++;
}

void outregs() {
    if (reset.read() == 0)
        count_out.write(0);
    else
        count_out.write(count);
}

};

```

To eliminate the nondeterminism of count in [Example 3-3](#), change count to an sc\_signal, as shown in bold in [Example 3-4](#). Notice that the only change in the code is the type declaration of count.

#### *Example 3-4 Correct Use of a Signal for Interprocess Communication*

```

/****mem_var_good.h****/
#include "systemc.h"

SC_MODULE(counter) {
    sc_in<bool> clk;
    sc_in<bool> reset_z;
    sc_out<sc_uint<4> > count_out;

    // Signal for interprocess communication
    sc_signal<sc_uint<4> > count;
    SC_CTOR(counter) {
        SC_METHOD(do_count);
        sensitive_pos << clk;
        sensitive_neg << reset_z;

        SC_METHOD(outregs);
        sensitive_pos << clk;
        sensitive_neg << reset_z;
    }
}

```

```
void do_count() {
    if (reset.read() == 0)
        count = 0;
    else
        count++;
}

void outregs() {
    if (reset.read() == 0)
        count_out.write(0);
    else
        count_out.write(count);
}

};
```

---

## Recommendations About Refinement for Synthesis

The following practices are recommended during refinement:

- After each step in refinement, reverify your design to ensure that you did not introduce errors during that step.
- Although it is recommended that you thoroughly refine at each refinement stage, it is not necessary. For example, during data refinement, you can refine one data type at a time and evaluate the impact on synthesizability and the quality of results. Similarly, you might want to replace one nonsynthesizable construct with a synthesizable construct and reverify the design before replacing the next nonsynthesizable construct.

# 4

## RTL Coding Guidelines

---

This chapter provides SystemC RTL coding guidelines.

It contains the following sections:

- [Register Inference](#)
- [Three-State Inference](#)
- [State Machines](#)

---

## Register Inference

Register inference allows you to use sequential logic in your designs and keep your designs technology-independent. A register is an array of 1-bit memory devices. A latch is a level-sensitive memory device, and a flip-flop is an edge-triggered memory device. Use the coding guidelines in this section to control flip-flop and latch inference.

As a recommended design practice, whenever you infer registers, ensure that the clock and data inputs to the registers can be directly controlled from the ports of the design. This ensures that you can initialize your design easily during simulation as well as in the actual circuit. You can, of course, infer registers with set and reset, which makes the task of register initialization easier and is highly recommended.

---

## Flip-Flop Inference

RTL synthesis can infer D flip-flops, JK flip-flops, and toggle flip-flops. The following sections provide details about each of these flip-flop types.

### Simple D Flip-flop

To infer a simple D flip-flop, make the SC\_METHOD process sensitive to only one edge of the clock signal. To infer a positive-edge-triggered flip-flop, make the process sensitive to the positive edge of the clock, and make the process sensitive to the negative edge to infer a negative-edge-triggered flip-flop.



RTL synthesis creates flip-flops for all the variables that are assigned values in the process. [Example 4-1](#) is a common SC\_METHOD process description that infers a flip-flop. [Figure 4-1](#) shows the inferred flip-flop.

### Example 4-1 *Inferring a Positive-Edge-Triggered Flip-Flop*

```
/* Positive edge-triggered DFF */

#include "systemc.h"

SC_MODULE (dff1) {
    sc_in<bool> in_data;
    sc_out<bool> out_q;
    sc_in<bool> clock;    // clock port

    // Method for D-flip-flop
    void do_dff_pos ();

    // Constructor
    SC_CTOR (dff1) {
        SC_METHOD (do_dff_pos);
        sensitive_pos << clock;
    }
};

void dff1::do_dff_pos()
{
    out_q.write(in_data.read());
}
```

Figure 4-1 *Inferred Positive-Edge-Triggered Flip-Flop*

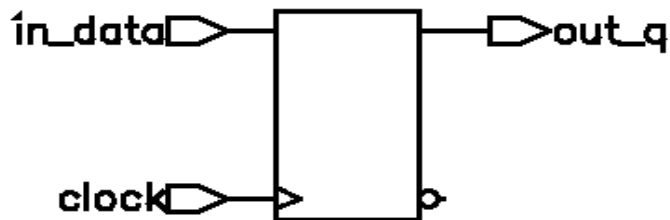

## D Flip-Flop With an Active-High Asynchronous Set or Reset

To infer a D flip-flop with an asynchronous set or reset, include edge expressions for the clock and the asynchronous signals in the sensitivity list of the SC\_METHOD process constructor. Specify the asynchronous signal conditions with an if statement in the SC\_METHOD process definition. [Example 4-2](#) shows a typical asynchronous specification. Specify the asynchronous branch conditions before you specify the synchronous branch conditions.

[Example 4-2](#) is a the SystemC description for a D flip-flop with an active-high asynchronous reset. [Figure 4-2](#) shows the inferred flip-flop.

### *Example 4-2 D Flip-Flop With an Active-High Asynchronous Reset*

```
/* Positive edge-triggered DFF */

#include "systemc.h"

SC_MODULE (dff3) {
    sc_in<bool> in_data, reset;
    sc_out<bool> out_q;
    sc_in<bool> clock;    // clock port

    void do_dff_pos ();

    // Constructor
    SC_CTOR (dff3) {
        SC_METHOD (do_dff_pos);
        sensitive_pos << clock << reset;
    }
};

void dff3::do_dff_pos () {
    if (reset.read())
        out_q.write(0);
    else
```

```

        out_q.write(in_data.read());
    }

```

Figure 4-2 D Flip-Flop With an Active-High Asynchronous Reset

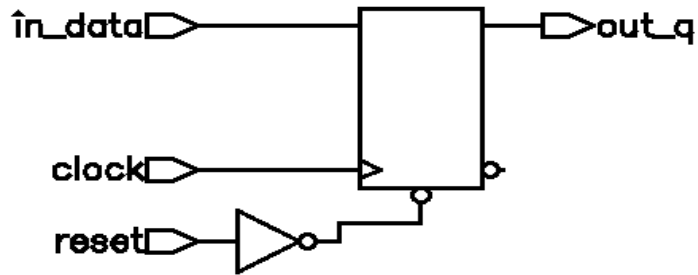

## D Flip-Flop With an Active-Low Asynchronous Set or Reset

Example 4-3 is a SystemC description for a D flip-flop with an active-low asynchronous reset. Figure 4-3 shows the inferred flip-flop.

Example 4-3 D Flip-Flop With an Active-Low Asynchronous Reset

```

/* Positive edge-triggered DFF
   with active low reset */

#include "systemc.h"

SC_MODULE (dff3a) {
    sc_in<bool> in_data, reset;
    sc_out<bool> out_q;
    sc_in<bool> clock;    // clock port

    void do_dff_pos ();

    // Constructor
    SC_CTOR (dff3a) {

```

```

        SC_METHOD (do_dff_pos);
        sensitive_pos << clock;
        sensitive_neg << reset;
    }
};

void dff3a::do_dff_pos () {
    if (reset.read() == 0)
        out_q.write(0);
    else
        out_q.write(in_data.read());
}

```

*Figure 4-3 D Flip-Flop With an Active-Low Asynchronous Reset*

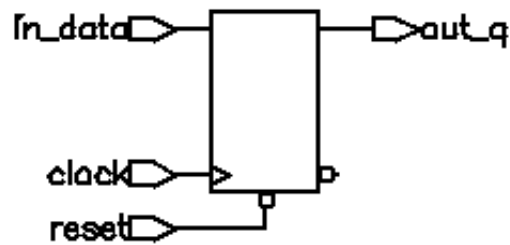

## D Flip-Flop With Active-High Asynchronous Set and Reset.

[Example 4-4](#) is a SystemC description for a D flip-flop with active-high asynchronous set and reset ports. [Figure 4-4](#) shows the inferred flip-flop.

An implied priority exists between set and reset, and reset has priority. This priority is not guaranteed, because it can be implemented differently in various technology libraries. To ensure the correct behavior, assign a high value to either the set or reset at one time, but not to both at the same time.

### *Example 4-4 Flip-Flop With Asynchronous Set and Reset*

```
/* Positive edge-triggered DFF */

#include "systemc.h"

SC_MODULE (dff4) {
    sc_in<bool> in_data, reset, set;
    sc_out<bool> out_q;
    sc_in<bool> clock;    // clock port

    void do_dff_pos ();

    // Constructor
    SC_CTOR (dff4) {
        SC_METHOD (do_dff_pos);
        sensitive_pos << clock << reset << set;
    }
};

void dff4::do_dff_pos () {
    if (reset.read())
        out_q.write(0);
    else if (set.read())
        out_q.write(1);
    else
        out_q.write(in_data.read());
}
```

Figure 4-4 Flip-Flop With Asynchronous Set and Reset

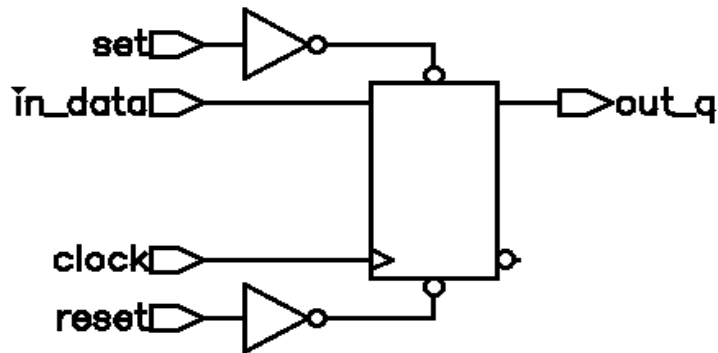

## D Flip-Flop With Synchronous Set or Reset

The previous examples illustrated how to infer a D flip-flop with asynchronous controls — one way to initialize or control the state of a sequential device. You can also synchronously reset or set a flip-flop.

If the target technology library does not have a D flip-flop with a synchronous reset, a D flip-flop with synchronous reset logic as the input to the D pin of the flip-flop is inferred. If the reset (or set) logic is not directly in front of the D pin of the flip-flop, initialization problems can occur during gate-level simulation of the design.

To specify a synchronous set or reset input, do not include it in the sensitivity list. Describe the synchronous set or reset test and action in an if statement. [Example 4-5](#) is a SystemC description for a D flip-flop with synchronous reset. [Figure 4-5](#) shows the inferred flip-flop.

### Example 4-5 D Flip-Flop With Synchronous Reset

```
/* Positive edge-triggered DFF */

#include "systemc.h"

SC_MODULE (dff5) {
    sc_in<bool> in_data, reset;
    sc_out<bool> out_q;
    sc_in<bool> clock;    // clock port

    // Method for D-flip-flop
    void dff ();

    // Constructor
    SC_CTOR (dff5) {
        SC_METHOD (dff);
        sensitive_pos << clock;
    }
};

void dff5::dff()
{
    if (reset.read())
        out_q.write(0);
    else
        out_q.write(in_data.read());
}
```

Figure 4-5 D Flip-Flop With Synchronous Reset

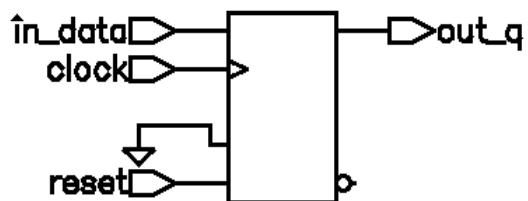

## Inferring JK Flip-Flops

Use a switch...case statement to infer JK flip-flops.

**JK Flip-Flop With Synchronous Set and Reset.** [Example 4-6](#) is the SystemC code that implements the JK flip-flop truth table described in [Table 4-1](#). In the JK flip-flop, the J and K signals are similar to active-high synchronous set and reset. [Figure 4-6](#) shows the inferred flip-flop.

*Table 4-1 Positive-Edge-Triggered JK Flip-Flop Truth Table*

J	K	CLK	Q <sub>n+1</sub>
0	0	Rising	Q <sub>n</sub>
0	1	Rising	0
1	0	Rising	1
1	1	Rising	$\overline{Q_n}$
X	X	Falling	Q <sub>n</sub>

### *Example 4-6 JK Flip-Flop*

```
/* Positive edge-triggered JK FF */

#include "systemc.h"

SC_MODULE (jkff1) {
    sc_in<bool> j, k;
    sc_inout<bool> q;    // inout to read q for toggle
    sc_in<bool> clk;    // clock port

    // Method for D-flip-flop
    void jk_flop ();

    // Constructor
```



```

SC_CTOR (jkff1) {
    SC_METHOD (jk_flop);
    sensitive_pos << clk;
}
};
void jkff1::jk_flop() {
    sc_uint<2> temp;           //temp to create vector
    temp[1] = j.read( );
    temp[0] = k.read( );
    switch(temp) {
    case 0x1: q.write(0);     // write a zero
        break;
    case 0x2: q.write(1);     // write a 1
        break;
    case 0x3:                 // toggle
        q.write(!q.read());
        break;
    default: break;         // no change
    }
}
}

```

Figure 4-6 JK Flip-Flop

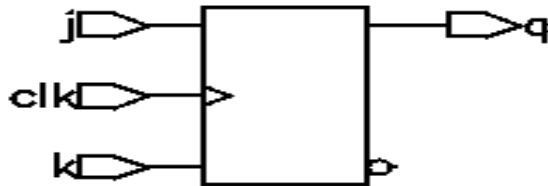

**JK Flip-Flop With Asynchronous Set and Reset.** [Example 4-7](#) is a SystemC description for a JK flip-flop with an active-low asynchronous set and reset. To specify an asynchronous set or reset, specify the signal in the sensitivity list as shown in [Example 4-7](#). [Figure 4-7](#) shows the inferred flip-flop.

*Example 4-7 JK Flip-Flop With Asynchronous Set and Reset*

```
/* Positive edge-triggered JKFF */

#include "systemc.h"

SC_MODULE (jkff2) {
    sc_in<bool> j, k, set, reset;
    sc_inout<bool> q;    // inout to read q for toggle
    sc_in<bool> clk;    // clock port

    // Method for D-flip-flop
    void jk_flop ();

    // Constructor
    SC_CTOR (jkff2) {
        SC_METHOD (jk_flop);
        sensitive_pos << clk;
        sensitive_neg << set << reset;
    }
};

void jkff2::jk_flop() {
    sc_uint<2> temp; //temp to create vector
    if (reset.read()==0)
        q.write(0); // reset
    else if (set.read()==0)
        q.write(1); // set
    else {
        temp[1] = j.read();
        temp[0] = k.read();
        switch(temp) {
            case 0x1: q.write(0); // write zero
                    break;
            case 0x2: q.write(1); // write a 1
                    break;
        }
    }
}
```

```

        case 0x3:                // toggle
            q.write(!q.read());
            break;
        default: break;         // no change
    }
}
}

```

Figure 4-7 JK Flip-Flop With Asynchronous Set and Reset

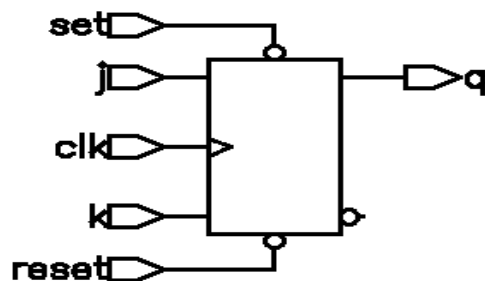

## Inferring Toggle Flip-Flops

This section describes the toggle flip-flop with an asynchronous set and the toggle flip-flop with an asynchronous reset.

**Toggle Flip-Flop With Asynchronous Set.** [Example 4-8](#) is a description for a toggle flip-flop with asynchronous set. The asynchronous set signal is specified in the sensitivity list. [Figure 4-8](#) shows the flip-flop.

Example 4-8 Toggle Flip-Flop With Asynchronous Set

```

#include "systemc.h"

SC_MODULE( tff1 ) {
    sc_in<bool> set, clk;
    sc_inout<bool> q;    // inout to read q for toggle

    void t_async_set_fcn ();
}

```

```

SC_CTOR( tff1 ) {
    SC_METHOD( t_async_set_fcn);
    sensitive_pos << clk << set;
}
};

void tff1::t_async_set_fcn () {
    if (set.read())
        q.write(1);
    else
        q.write(!q.read());
}

```

*Figure 4-8 Toggle Flip-Flop With Asynchronous Set*

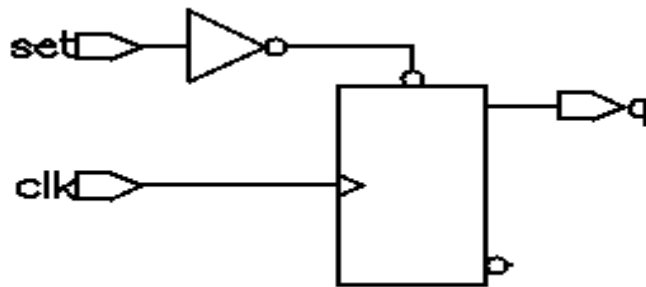

**Toggle Flip-Flop With Asynchronous Reset.** [Example 4-9](#) is a SystemC description for a toggle flip-flop with asynchronous reset. The asynchronous reset signal is specified in the sensitivity list. [Figure 4-9](#) shows the inferred flip-flop.

*Example 4-9 Toggle Flip-Flop With Asynchronous Reset*

```
#include "systemc.h"

SC_MODULE( tff2 ) {
    sc_in<bool> reset, clk;
    sc_inout<bool> q; // to read q for toggle

    void t_async_reset_fcn();

    SC_CTOR( tff2 ) {
        SC_METHOD( t_async_reset_fcn);
        sensitive_pos << clk << reset;
    }
};

void tff2::t_async_reset_fcn () {
    if (reset.read())
        q.write(0);
    else
        q.write(!q.read());
}
```

*Figure 4-9 Toggle Flip-Flop With Asynchronous Reset*

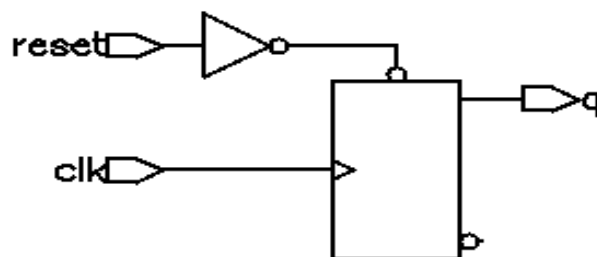

---

## Latch Inference

In simulation, a signal or variable holds its value until that value is reassigned. A latch implements the ability to hold a state in hardware. RTL synthesis supports inference of set/reset (SR) and delay (D) latches.

You can unintentionally infer latches from your SystemC code, which can add unnecessary hardware. RTL synthesis infers a D latch when your description has an incomplete assignment in an if...else or switch...case statement. To avoid creating a latch, specify all conditions in if...else and switch...case statements, and assign all variables in all branches.

### Inferring a D Latch From an If Statement

An if statement infers a D latch when there is no else clause, as shown in [Example 4-10](#). The SystemC code specifies a value for output out\_q only when the clock has a logic 1 value, and it does not specify a value when the clock has a logic 0 value. As a result, output out\_q becomes a latched value. [Figure 4-10](#) shows the schematic of the inferred D latch.

#### *Example 4-10 Latch Inference Using an if Statement*

```
#include "systemc.h"

SC_MODULE( d_latch1 ) {
    sc_in<bool> in_data;
    sc_in<bool> clock;
    sc_out<bool> out_q;

    // Method process
    void d_latch_fcn () {
        if (clock.read())
            out_q.write(in_data.read());
    }
}
```

```

// Constructor
SC_CTOR( d_latch1 ) {
    SC_METHOD( d_latch_fcn);
    sensitive << in_data << clock;
}
};

```

Figure 4-10 D Latch Inferred From an if Statement

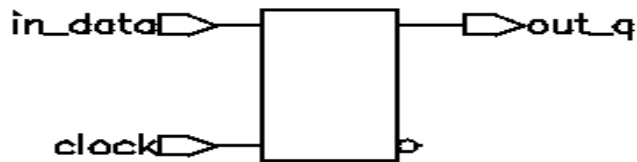

## Inferring an SR Latch

SR latches are difficult to test, so use them with caution. If you use SR latches, verify that the inputs are hazard-free and do not generate glitches. RTL synthesis does not ensure that the logic driving the inputs is hazard-free.

[Example 4-8](#) is the SystemC code that implements the truth table in [Table 4-1](#). [Figure 4-8](#) shows the inferred SR latch.

Output *y* is unstable when both inputs are at a logic 0 value, so you need to include a check in the SystemC code to detect this condition during simulation. RTL synthesis does not support these checks.

*Table 4-2 Truth Table for the SR Latch (NAND Type)*

set	reset	Q
0	0	Not stable
0	1	1
1	0	0
1	1	Q

*Example 4-11 SR Latch*

```
/* SR_LATCH-latch */  
  
#include "systemc.h"  
  
SC_MODULE( sr_latch ) {  
    sc_in<bool> RESET, SET;  
    sc_out<bool> Q;  
  
    void sr_latch_fcn () {  
        if (RESET.read() == 0)  
            Q.write(0);  
        else if (SET.read() == 0)  
            Q.write(1);  
    }  
  
    SC_CTOR( sr_latch ) {  
        SC_METHOD( sr_latch_fcn);  
        sensitive << RESET << SET;  
    }  
};
```



Figure 4-11 SR Latch

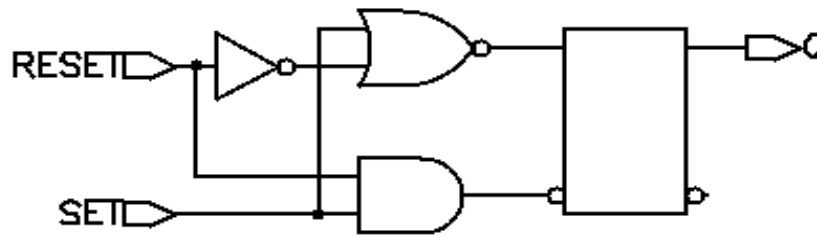

## Avoiding Latch Inference

To avoid latch inference, assign a value to a signal for all cases in a conditional statement. [Example 4-13](#) shows addition of an else clause to avoid the latch inferred by the if statement in [Example 4-10](#), and [Figure 4-12](#) shows the resulting schematic.

Example 4-12 Adding an Else Clause to Avoid Latch Inference

```
#include "systemc.h"

SC_MODULE( d_latch1a ) {
    sc_in<bool> in_data;
    sc_in<bool> clock;
    sc_out<bool> out_q;

    // Method process
    void d_latch_fcn () {
        if (clock.read())
            out_q.write(in_data.read());
        else
            out_q.write(false);
    }

    // Constructor
    SC_CTOR( d_latch1a ) {
        SC_METHOD( d_latch_fcn );
        sensitive << in_data << clock;
    }
};
```

Figure 4-12 Avoiding Latch Inference by Adding Else Clause

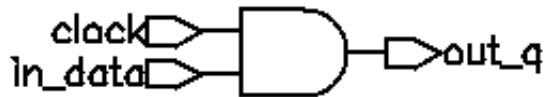

You can also avoid latch inference by assigning a default value to the output port. [Example 4-13](#) shows setting a default value to avoid the latch inferred by the if statement in [Example 4-10](#), and [Figure 4-13](#) shows the resulting schematic.

Example 4-13 Setting a Default Value to Avoid Latch Inference

```
#include "systemc.h"

SC_MODULE( d_latch1 ) {
    sc_in<bool> in_data;
    sc_in<bool> clock;
    sc_out<bool> out_q;

    // Method process
    void d_latch_fcn () {
        out_q.write(1);      // set a default
        if (clock.read())
            out_q.write(in_data.read());
    }

    // Constructor
    SC_CTOR( d_latch1 ) {
        SC_METHOD( d_latch_fcn);
        sensitive << in_data << clock;
    }
};
```

Figure 4-13 Avoiding Latch Inference by a Default Value

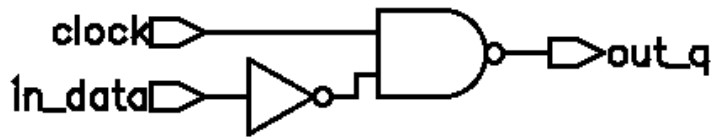

## Inferring a Latch From a Switch Statement

[Example 4-14](#) shows a switch statement that infers D latches because the switch statement does not provide assignments to the out port for all possible values of the in\_i input. [Figure 4-14](#) shows the inferred latches.

Example 4-14 Latch Inference From a switch Statement

```
#include "systemc.h"

SC_MODULE( d_latch2 ) {
    sc_in<unsigned char> in_i;
    sc_out<unsigned char> out;

    // Method process
    void d_latch_fcn () {
        switch (in_i.read()) {
            case 0: out.write(0x01); break;
            case 1: out.write(0x02); break;
            case 2: out.write(0x04); break;
            case 3: out.write(0x10); break;
            case 4: out.write(0x20); break;
            case 5: out.write(0x40); break;
        }
    }

    // Constructor
    SC_CTOR( d_latch2 ) {
        SC_METHOD( d_latch_fcn );
        sensitive (in_i);
    }
};
```

Figure 4-14 Latch Inference From a switch Statement

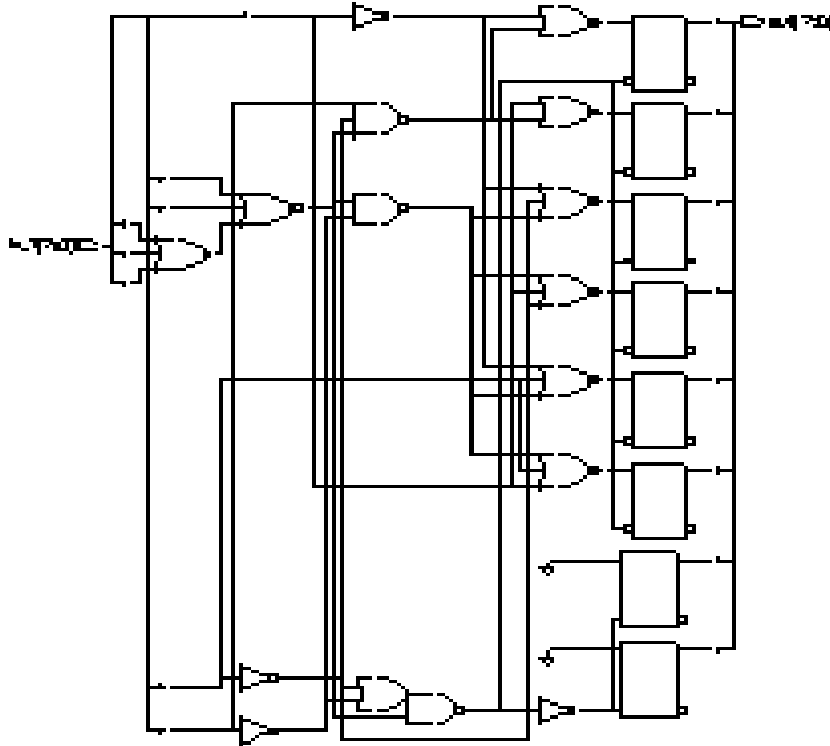

To avoid latch inference caused by the incomplete switch statement in [Example 4-14](#), add a default case statement, as shown in [Example 4-15](#). [Figure 4-15](#) shows the resulting schematic.

Example 4-15 Avoiding Latch Inference From a switch Statement

```
#include "systemc.h"

SC_MODULE( d_latch2a ) {
    sc_in<unsigned char> in_i;
    sc_out<unsigned char> out;

    // Method process
    void d_latch_fcn () {
        switch (in_i.read()) {
            case 0: out.write(0x01); break;
            case 1: out.write(0x02); break;
        }
    }
}
```

```

    case 2: out.write(0x04); break;
    case 3: out.write(0x10); break;
    case 4: out.write(0x20); break;
    case 5: out.write(0x40); break;
    default: out.write(0x01);
  }
}

// Constructor
SC_CTOR( d_latch2a ) {
  SC_METHOD( d_latch_fcn);
  sensitive (in_i);
}
};

```

**Figure 4-15** *Avoiding Latch Inference by Adding a Default Case to a switch Statement*

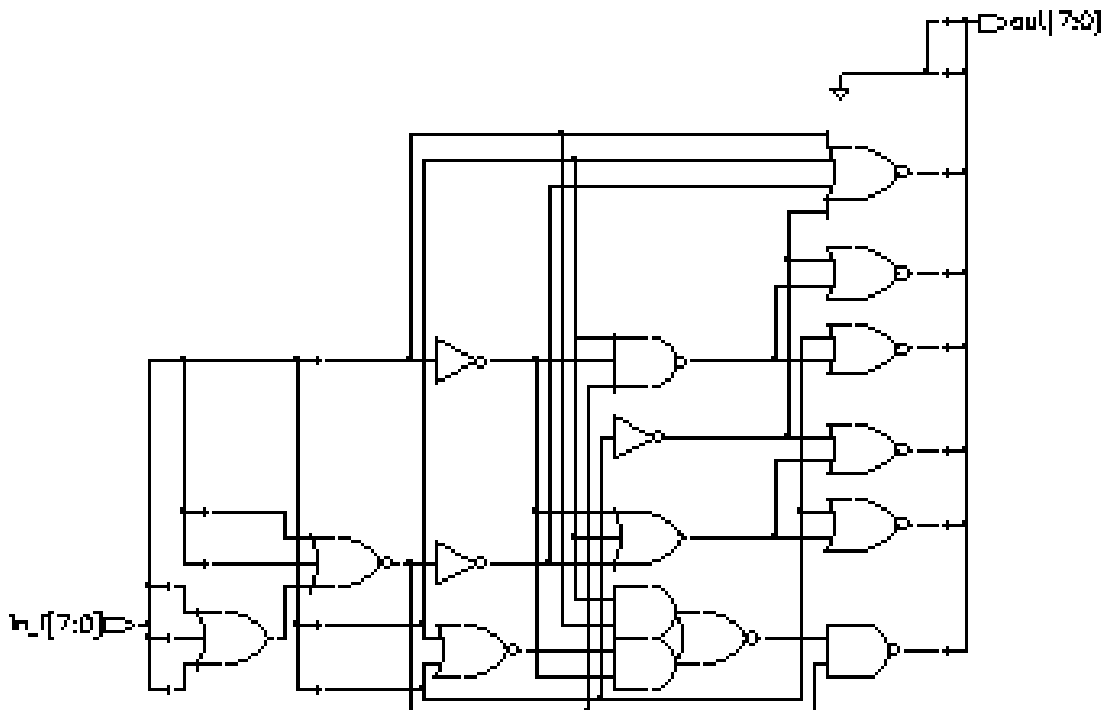

You can also avoid latch inference caused by the incomplete switch statement in [Example 4-14](#) by writing a default value to the output port, as shown in [Example 4-16](#). [Figure 4-16](#) shows the resulting schematic.

***Example 4-16 Set a Default Value to Avoid Latch Inference From a switch Statement***

```
#include "systemc.h"

SC_MODULE( d_latch2b ) {
    sc_in<unsigned char> in_i;
    sc_out<unsigned char> out;

    // Method process
    void d_latch_fcn () {
        out.write(1); // Set default value
        switch (in_i.read()) {
            case 0: out.write(0x01); break;
            case 1: out.write(0x02); break;
            case 2: out.write(0x04); break;
            case 3: out.write(0x10); break;
            case 4: out.write(0x20); break;
            case 5: out.write(0x40); break;
        }
    }

    // Constructor
    SC_CTOR( d_latch2b ) {
        SC_METHOD( d_latch_fcn);
        sensitive (in_i);
    }
};
```

Figure 4-16 *Avoiding Latch Inference by Setting a Default Case Before a switch Statement*

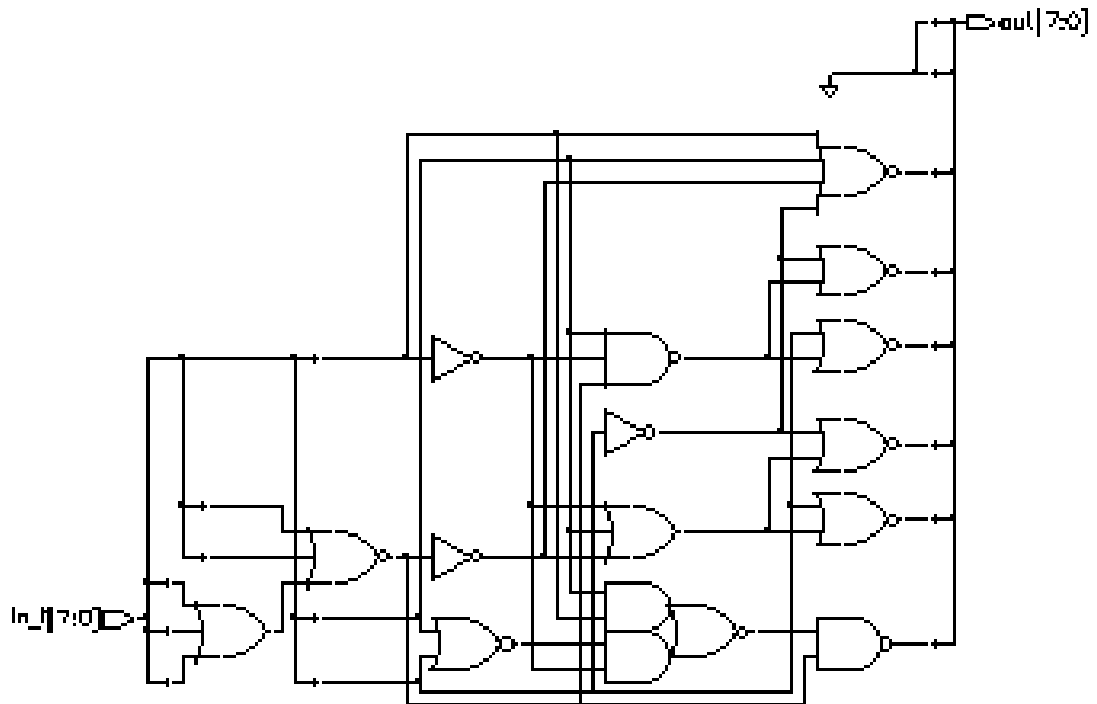

### Active-Low Set and Reset

To instruct RTL synthesis to implement all signals in the group as active-low, add a check to the SystemC code to ensure that the group of signals has only one active-low signal at a given time. RTL synthesis does not produce any logic to check this assertion.

[Example 4-3](#) shows a latch with an active-low set and reset. [Figure 4-3](#) shows the resulting schematic.

### Example 4-17 Latch With Active-Low Set and Reset

```
#include "systemc.h"

SC_MODULE( d_latch6a ) {
    sc_in<bool> in_data, set, reset;
    sc_in<bool> clock;
    sc_out<bool> out_q;

    void d_latch_fcn () {
        infer_latch: {
            if (reset.read() == 0)
                out_q.write(0);
            else if (set.read() == 0)
                out_q.write(1);
            else if (clock.read())
                out_q.write(in_data.read());
        }
    }
    // Constructor
    SC_CTOR( d_latch6a ) {
        SC_METHOD( d_latch_fcn);
        sensitive << in_data << clock << set << reset;
    }
};
```

Figure 4-17 Latch With Active-Low Set and Reset

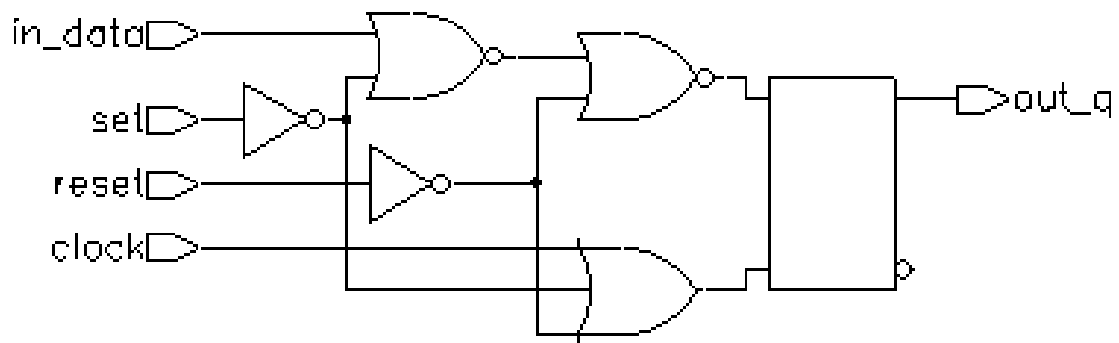



## Active-High Set and Reset

To instruct RTL synthesis to implement all signals in the group as active-high, add a check to the SystemC code to ensure that the group of signals has only one active-high signal at a given time. RTL synthesis does not produce any logic to check this assertion.

[Example 4-3](#) shows a latch with the set and reset specified as active-high. [Figure 4-3](#) shows the resulting schematic.

### *Example 4-18 Latch With Active-High Set and Reset*

```
#include "systemc.h"

SC_MODULE( d_latch7a ) {
    sc_in<bool> in_data, set, reset;
    sc_in<bool> clock;
    sc_out<bool> out_q;

    void d_latch_fcn () {
        infer_latch: {
            if (reset.read())
                out_q.write(0);
            else if (set.read())
                out_q.write(1);
            else if (clock.read())
                out_q.write(in_data.read());
        }
    }
    // Constructor
    SC_CTOR( d_latch7a ) {
        SC_METHOD( d_latch_fcn );
        sensitive << in_data << clock << set << reset;
    }
};
```

Figure 4-18 Latch With Active-High Set and Reset

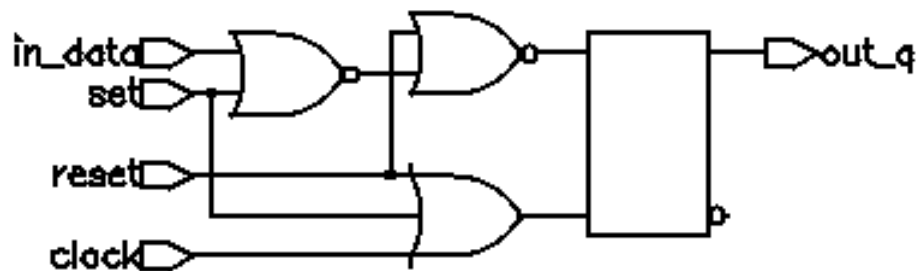

## D Latch With an Asynchronous Set and Reset

[Example 4-5](#) is a SystemC description for a D latch with an active-low asynchronous set and reset. [Figure 4-5](#) shows the inferred latch.

Example 4-19 Latch With Asynchronous Set and Reset

```
#include "systemc.h"

SC_MODULE( d_latch6 ) {
    sc_in<bool> in_data, set, reset;
    sc_in<bool> clock;
    sc_out<bool> out_q;

    void d_latch_fcn () {
        if (reset.read() == 0)
            out_q.write(0);
        else if (set.read() == 0)
            out_q.write(1);
        else if (clock.read())
            out_q.write(in_data.read());
    }
    // Constructor
    SC_CTOR( d_latch6 ) {
        SC_METHOD( d_latch_fcn );
        sensitive << in_data << clock << set << reset;
    }
};
```

Figure 4-19 Latch With Asynchronous Set and Reset

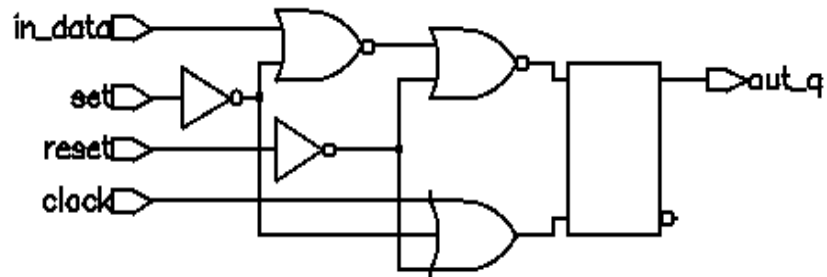

## D Latch With an Asynchronous Set

Example 4-6 is a SystemC description for a D latch with an asynchronous set. Figure 4-6 shows the inferred latch.

Example 4-20 Latch With Asynchronous Set

```
#include "systemc.h"

SC_MODULE( d_latch4 ) {
    sc_in<bool> in_data, set;
    sc_in<bool> clock;
    sc_out<bool> out_q;

    void d_latch_fcn () {
        if (set.read() == 0)
            out_q.write( 1 );
        else if (clock.read())
            out_q.write(in_data.read());
    }

    // Constructor
    SC_CTOR( d_latch4 ) {
        SC_METHOD( d_latch_fcn);
        sensitive << in_data << clock << set;
    }
};
```

Figure 4-20 Latch With Asynchronous Set

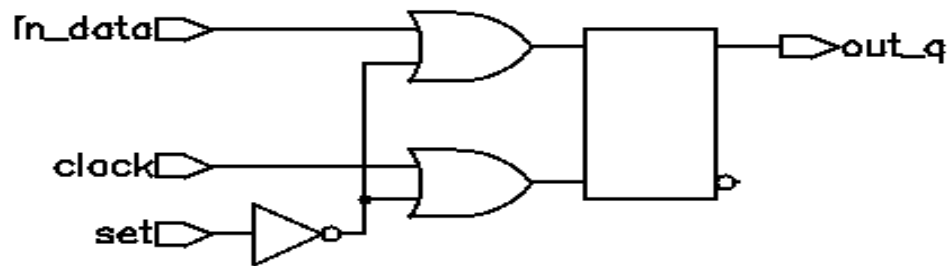

## D Latch With an Asynchronous Reset

Example 4-7 is a SystemC description for a D latch with an asynchronous reset. Figure 4-7 shows the inferred latch.

Example 4-21 Latch With Asynchronous Reset

```
#include "systemc.h"

SC_MODULE( d_latch5 ) {
    sc_in<bool> in_data, reset;
    sc_in<bool> clock;
    sc_out<bool> out_q;

    void d_latch_fcn () {
        if (reset.read() == 0)
            out_q.write(0);
        else if (clock.read())
            out_q.write(in_data.read());
    }
    // Constructor
    SC_CTOR( d_latch5 ) {
        SC_METHOD( d_latch_fcn);
        sensitive << in_data << clock << reset;
    }
};
```

Figure 4-21 Latch With Asynchronous Reset

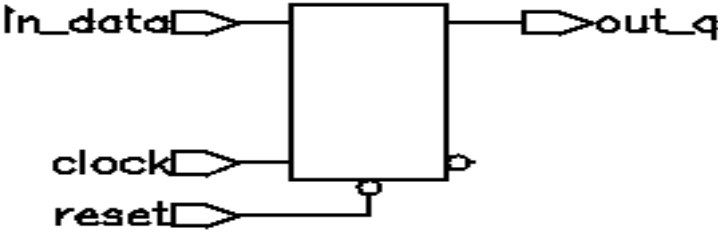

---

## Three-State Inference

A three-state driver is inferred when you assign the value Z to a variable. The value Z represents the high-impedance state. You can assign high-impedance values to single-bit or bused variables. The assignment must occur in a conditional statement (if or switch) or with the conditional operator (?:). Note that only the `sc_logic` and `sc_lv` data types support the value Z.

---

### Simple Three-State Inference

[Example 4-22](#) is a SystemC description for a simple three-state driver. [Figure 4-22](#) shows the schematic the code generates.

#### *Example 4-22 Three-State Buffer Inference From a Block of Code*

```
// simple three-state buffer inference
#include "systemc.h"

SC_MODULE( tristate_ex1 ) {
    sc_in<bool> control;
    sc_in<sc_logic> data;
    sc_out<sc_logic> ts_out;

    // Method for three-state driver
    void tristate_fcn () {
        if (control.read())
            ts_out.write(data.read());
        else
            ts_out.write('Z');
    }

    // Constructor
    SC_CTOR( tristate_ex1 ) {
        SC_METHOD( tristate_fcn);
        sensitive << control << data;
    }
};
```

Figure 4-22 Schematic of a Simple Three-State Driver

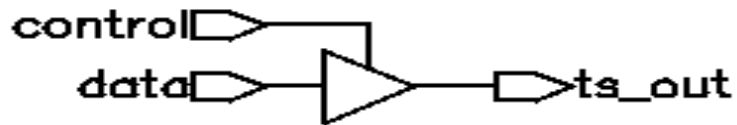

[Example 4-23](#) is a different instance of three-state inference. In this case, the output is computed and RTL synthesis infers a single three-state driver. [Figure 4-23](#) shows the schematic the code generates.

Example 4-23 Inferring One Three-State Driver

```
// simple three-state buffer inference
#include "systemc.h"

SC_MODULE( tristate_ex2 ) {
    sc_in<bool> in_sela, in_selb;
    sc_in<sc_logic> in_a, in_b;
    sc_out<sc_logic> out_1;

    // Method for single three-state driver
    void tristate_fcn () {
        out_1.write('Z'); //default value
        if (in_sela.read())
            out_1.write(in_a.read());
        else if (in_selb.read())
            out_1.write(in_b.read());
    }

    // Constructor
    SC_CTOR( tristate_ex2 ) {
        SC_METHOD( tristate_fcn);
        sensitive << in_sela << in_selb << in_a << in_b;
    }
};
```

Figure 4-23 Three-State Driver With Gated Data

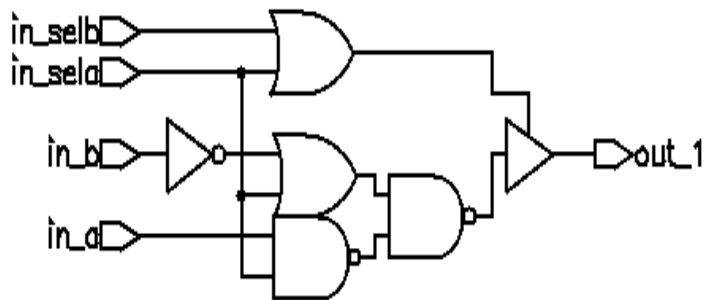

---

## Registered Three-State Drivers

When a variable is registered in the same process in which it is in a three-state condition, RTL synthesis also registers the enable pin of the three-state gate. [Example 4-24](#) is an example of this type of code. [Figure 4-24](#) shows the schematic generated by the code.

Example 4-24 Three-State Driver With Registered Enable

```
// simple three-state buffer inference
#include "systemc.h"

SC_MODULE( tristate_ex4 ) {
    sc_in<bool> control;
    sc_in<sc_logic> data;
    sc_out<sc_logic> ts_out;
    sc_in_clk clk;

    // Method for three-state driver
    void tristate_fcn () {
        if (control.read())
            ts_out.write(data.read());
        else
            ts_out.write('Z');
    }

    // Constructor
    SC_CTOR( tristate_ex4 ) {
```



```

        SC_METHOD( tristate_fcn);
        sensitive_pos << clk; // note inferred seq logic
    }
};

```

Figure 4-24 Three-State Driver With Registered Enable

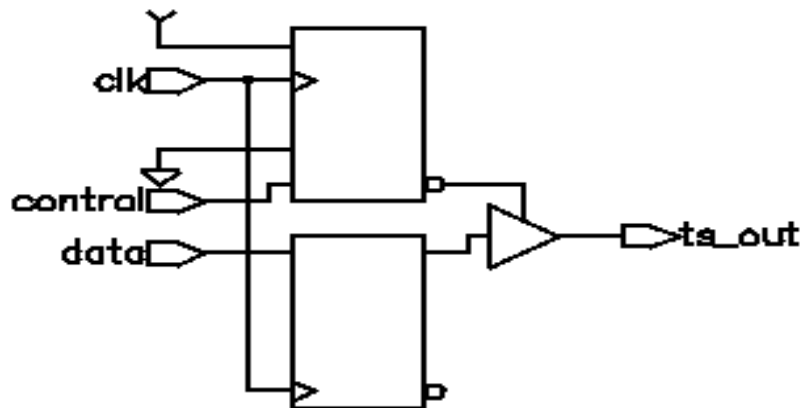

To avoid registering the enable pin, separate the three-state driver inference from the sequential logic inference, using two SC\_METHOD processes. [Example 4-25](#) uses two methods to instantiate a three-state gate, with a flip-flop only on the input. Note that the sc\_signal temp is used to communicate between the two SC\_METHOD processes. [Figure 4-25](#) shows the schematic the code generates.

Example 4-25 Three-State Driver Without Registered Enable

```

// simple three-state buffer inference
#include "systemc.h"

SC_MODULE( tristate_ex5 ) {
    sc_in<bool> control;
    sc_in<sc_logic> data;
    sc_out<sc_logic> ts_out;
    sc_in_clk clk;

    sc_signal<sc_logic> temp;

```

```

// Method for three-state driver
void tristate_fcn () {
    if (control.read())
        ts_out.write(temp);
    else
        ts_out.write('Z');
}

// Method for sequential logic
void flop () {
    temp = data.read();
}

// Constructor
SC_CTOR( tristate_ex5 ) {
    SC_METHOD( tristate_fcn);
    sensitive << control << temp ;
    SC_METHOD( flop );
    sensitive_pos << clk;
}
};

```

Figure 4-25 Three-State Driver Without Registered Enable

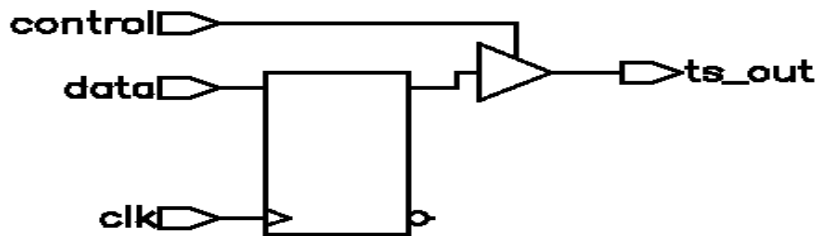

---

## State Machines

Explicitly describe state machines for RTL synthesis. [Figure 4-26](#) shows a Mealy state machine structure.

*Figure 4-26 Mealy State Machine*

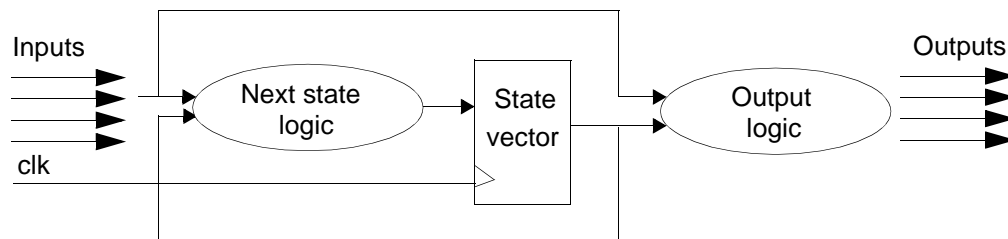

The diagram in [Figure 4-26](#) has one sequential element—the state vector—and two combinational elements, the output logic and the next state logic. Although the output logic and the next state logic are separate in this diagram, you can merge them into one logic block where gates can be shared for a smaller design area.

The output logic is always a function of the current state (state vector) and optionally a function of the inputs. If inputs are included in the output logic, it is a Mealy state machine. If inputs are not included, it is a Moore state machine.

The next state logic is always a function of the current state (state vector) and optionally a function of the inputs.

The common implementations of state machines are

- An `SC_METHOD` process for updating the state vector and a single common `SC_METHOD` process for computing both the output and next-state logic

- An SC\_METHOD process for updating the state vector, an SC\_METHOD process for the computing the output logic, and a separate SC\_METHOD process for computing the next-state logic
- A Moore machine with a single process for computing and updating the next-state vector and outputs

Figure 4-27 shows a state diagram that represents an example state machine, where a and b represent the outputs.

Figure 4-27 Finite State Machine State Diagram

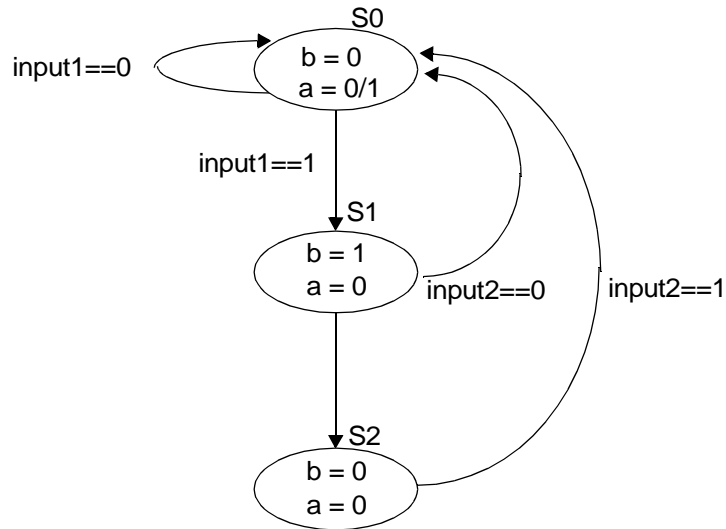

---

## State Machine With a Common Computation Process

[Example 4-26](#) shows the state machine (represented in [Figure 4-27](#)) with a common SC\_METHOD process for computing the output and next-state logic.

### *Example 4-26 State Machine With a Common Computation Process*

```
SC_MODULE(ex_fsm_a){
    sc_in_clk clk;
    sc_in<bool> rst, input1, input2;
    sc_out<bool> a, b;

    sc_signal<state_t> state, next_state;

    void ns_op_logic();
    void update_state();

    SC_CTOR(ex_fsm_a){
        SC_METHOD(update_state);
        sensitive_pos << clk;
        SC_METHOD(ns_op_logic);
        sensitive << state << input1 << input2;
    }
};

enum state_t { // enumerate states
    S0, S1, S2
};

void ex_fsm_a::update_state() {
    if (rst.read() == true)
        state = S0;
    else
        state = next_state;
}

void ex_fsm_a::ns_op_logic() {
    // Determine next state and output logic
    switch(state) {
        case S0:
```

```

        b.write(0);
        if (input1.read() || input2.read())
            a.write(1);
        else
            a.write(0);
        if (input1.read() == 1)
            next_state = S1;
        else
            next_state = S0;
        break;
    case S1:
        a.write(0);
        b.write(1);
        if (input2.read() == 1)
            next_state = S2;
        else
            next_state = S0;
        break;
    case S2:
        a.write(0);
        b.write(0);
        next_state = S0;
        break;
    default:
        a.write(0);
        b.write(0);
        next_state = S0;
        break;
}
}

```

---

## State Machine With Separate Computation Processes

[Example 4-27](#) shows the state machine (represented in [Figure 4-27](#)) with separate SC\_METHOD processes for computing the output and next-state logic.

### *Example 4-27 State Machine With Separate Computation Processes*

```
SC_MODULE(fsm_b) {
    sc_in_clk clk;
    sc_in<bool> rst, input1, input2;
    sc_out<bool> a, b;

    sc_signal<state_t> state, next_state;

    void ns_op_logic();
    void output_logic();
    void update_state();

    SC_CTOR(fsm_b) {
        SC_METHOD(update_state);
        sensitive_pos << clk;
        SC_METHOD(ns_logic);
        sensitive << state << input1 << input2;
        SC_METHOD(output_logic);
        sensitive << state << input1 << input2;
    }
};

enum state_t { // enumerate states
    S0, S1, S2
};

void fsm_b::update_state() {
    if (rst.read() == true)
        state = S0;
    else
        state = next_state;
}

void fsm_b::ns_logic() { // Determine next state
```

```

switch(state) {
  case S0:
    if (input1.read() == 1)
      next_state = S1;
    else
      next_state = S0;
    break;
  case S1:
    if (input2.read() == 1)
      next_state = S2;
    else
      next_state = S0;
    break;
  case S2:
    next_state = S0;
    break;
  default:
    next_state = S0;
    break;
}
}

void fsm_b::output_logic() // determine outputs
{
  a.write(state == S0 && (input1.read()
    || input2.read() ) );
  b.write(state == S1);
}

```



---

## Moore State Machine

[Example 4-27](#) shows a Moore state machine with a single SC\_METHOD process for computing and updating the output and next-state logic.

### *Example 4-28 Moore State Machine*

```
/**ex_fsm_c.h***/
SC_MODULE(ex_fsm_c){

    sc_in_clk clk;
    sc_in<bool> rst, input1, input2;
    sc_out<bool> a, b;

    sc_signal<state_t> state;

    void update_state();

    SC_CTOR(ex_fsm_c){
        SC_METHOD(update_state);
        sensitive_pos << clk;
    }
};

/**ex_fsm_c.cpp***/
#include <iostream.h>
#include "systemc.h"
#include "fsm_types.h"
#include "ex_fsm_c.h"

void ex_fsm_c::update_state() {
    if (rst.read() == true) {
        b.write(0);
        a.write(0);
        state = S0;
    } else {
        switch(state) {
        case S0:
            b.write(0);
            if (input1.read() || input2.read())
```

```
    a.write(1);
    else
    a.write(0);
    if (input1.read() == 1)
    state = S1;
    break;
case S1:
    a.write(0);
    b.write(1);
    if(input2.read() == 1)
    state = S2;
    break;
case S2:
    a.write(0);
    b.write(0);
    state = S0;
    break;
}
}
}
```



