

Pioneer

DVD-ROM DRIVE UNIT

DVD-D7361

Operating instructions

English Section

This product complies with the EMC Directives (89/336/EEC, 92/31/EEC) and CE Marking Directive (93/68/EEC).

Ce produit est conforme aux directives relatives à la compatibilité électromagnétique (89/336/CEE, 92/31/CEE) et à la directive CE relative aux marquages (93/68/CEE).

Dieses Produkt entspricht den EMV-Richtlinien (89/336/EEC, 92/31/EEC) und CE-Markierungsrichtlinien (93/68/EEC).

Questo prodotto è conforme alle direttive EMC (89/336/CEE, 92/31/CEE) e alla direttiva sul marchio CE (93/68/CEE).

Dit produkt voldoet aan de EMC-richtlijnen (89/336/EEC en 92/31/EEC) en de CE-markeringsrichtlijn (93/68/EEC).

Denna produkt uppfyller föreskrifterna i EMC-direktiv (89/336/EEC, 92/31/EEC) och CE-märkningsdirektiv (93/68/EEC).

Este producto cumple con las Directivas EMC (89/336/CEE, 92/31/CEE) y Directiva de Marcación CE (93/68/CEE).

Este produto cumpre com as Directivas EMC (89/336/CEE, 92/31/CEE) e Directiva da Marcação CE (93/68/CEE).

Dette produkt er i overensstemmelse med direktiverne vedrørende elektromagnetisk kompatibilitet (89/336/EEC, 92/31/EEC) og CE-direktivet vedrørende mærkning (93/68/EEC).

WARNING!

Om apparaten används på annat sätt än i denna bruksanvisning specificerats, kan användaren utsättas för osynlig laserstrålning som överskrider gränsen för laserklass 1.

ADVARSEL:

Usynlig laserstråling ved åbning når sikkerhedsafbrydere er ude af funktion. Undgå udsættelse for stråling.

VAROITUS!

Laitten käyttäminen muulla kuin tässä käyttöohjeessa mainitulla tavalla saattaa altistaa käyttäjän turvallisuusluokan 1 ylittävälle näkymättömälle lasersäteilylle.



LASER DIODE – This product contains a laser diode. To assure continued safety, **DO NOT** remove any covers or attempt to gain access to the inside of the product.

CAUTION:

USE OF CONTROLS OR ADJUSTMENTS OR PERFORMANCE OF PROCEDURES OTHER THAN THOSE SPECIFIED HEREIN MAY RESULT IN HAZARDOUS RADIATION EXPOSURE.

CAUTION:

USE OF OPTICAL INSTRUMENTS WITH THIS PRODUCT WILL INCREASE EYE HAZARD.

Thank you for buying this Pioneer product. Please read through these operating instructions so you will know how to operate your model properly.

This product is an optional drive designed for exclusive use as the 700-disc changers, models DRM-7000. This means that this unit cannot be used alone or connected to other equipment than specified.

The export of this product or devices in which this product has been installed from Japan is regulated by Japanese government. The export of this product may be prohibited without governmental license. To export or re-export of this product from a country other than Japan may also be prohibited without an export license from the country involved.

WARNING: TO PREVENT FIRE OR SHOCK HAZARD, DO NOT EXPOSE THIS APPLIANCE TO RAIN OR MOISTURE.

IMPORTANT NOTICE:

RECORD THE MODEL NUMBER AND SERIAL NUMBER OF THIS EQUIPMENT BELOW. THE NUMBERS ARE ON THE TOP PANEL.

MODEL NO. DVD-D7361

SERIAL NO. _____

KEEP THESE NUMBERS FOR FUTURE USE.

IMPORTANT



The lightning flash with arrowhead symbol, within an equilateral triangle, is intended to alert the user to the presence of uninsulated "dangerous voltage" within the product's enclosure that may be of sufficient magnitude to constitute a risk of electric shock to persons.

CAUTION

**RISK OF ELECTRIC SHOCK
DO NOT OPEN**

CAUTION:

TO PREVENT THE RISK OF ELECTRIC SHOCK, DO NOT REMOVE COVER (OR BACK). NO USER-SERVICEABLE PARTS INSIDE. REFER SERVICING TO QUALIFIED SERVICE PERSONNEL.



The exclamation point within an equilateral triangle is intended to alert the user to the presence of important operating and maintenance (servicing) instructions in the literature accompanying the appliance.

IMPORTANT

CAUTION

This product contains a laser diode of higher class than 1. To ensure continued safety, do not remove any covers or attempt to gain access to the inside of the product.

Refer all servicing to qualified personnel.

The following caution label appears on your unit.

Location: on top of the cover

**CLASS 1 LASER PRODUCT
LASER KLASSE 1**

For pluggable equipment the socket-outlet shall be installed near the equipment and shall be easily accessible.

This equipment has been tested and found to comply with the limits for a Class A digital device, pursuant to Part 15 of the FCC Rules. These limits are designed to provide reasonable protection against harmful interference when the equipment is operated in a commercial environment. This equipment generates, uses, and can radiate radio frequency energy and, if not installed and used in accordance with the instruction manual, may cause harmful interference to radio communications. Operation of this equipment in a residential area is likely to cause harmful interference in which case the user will be required to correct the interference at his own expense.

[For Canadian model]

This Class A digital apparatus complies with Canadian ICES-003.

[Pour le modèle Canadien]

Cet appareil numérique de la Classe A est conforme à la norme NMB-003 du Canada.

Information to User

Alteration or modifications carried out without appropriate authorization may invalidate the user's right to operate the equipment.

*The Generation of Acoustical Noise Is Less Than 70dB.
(ISO7779/DIN45635)*

FOR ENGLAND

Warning

This is a class A product. In a domestic environment this product may cause radio interference in which cause the user may be required to take adequate measures.

FOR FRANCE

Attention

Ce produit est de classe A. Dans un environnement domestique, il peut entraîner des interférences et l'utilisateur peut alors être amène à prendre les mesures qui s'imposent.

FOR GERMANY

Warnung

Dies ist ein Produkt der Klasse A. In einer häuslichen Umgebung kann dieses Produkt Störgeräusche (Funkstörungen) verursachen. In diesem Fall kann es erforderlich sein, geeignete Maßnahmen zu ergreifen.

FOR ITALY

Avvertenza

Questo è un prodotto di classe A. In ambiente domestico, questo prodotto può provocare interferenze radio per le quali l'utente deve adottare contromisure adeguate.

FOR SPAIN

Advertencia

Este es un producto de clase A. En un entorno doméstico, este producto Puede causar radiointerferencias internas que obliguen al usuario a tomar las medidas adecuadas.

FOR PORTUGAL

Aviso

Este produto pertence à classe A. Quando num ambiente doméstico este produto pode provocar rádio interferências para as quais o utilizador pode ter que tomar medidas adequadas.

FOR BELGIUM AND NETHERLANDS

Waarschuwing

Dit is een product dat tot klasse A behoort. In woningen kan dit product radiostoringen veroorzaken. In voorkomend geval moet de gebruiker gepaste maatregelen nemen.

FOR DENMARK

Advarsel

Dette er et klasse A-produkt, som kan forårsage radiointerferens ved brug i hjemmet. Hvis det er tilfældet, kan brugeren blive nødt til tage passende forholdsregler.

FOR SWEDEN

Varning

Det här är en klass A-produkt. I hemmiljö kan radiostörningar uppstå och användaren bör då vidta lämpliga åtgärder.

SAFETY INSTRUCTIONS

To ensure your personal safety and to maximize the full operating potential of your Drive, read and follow these safety precautions:

ENVIRONMENT - Please use the unit at a place where it is not subjected to vibrations or shocks.

READ INSTRUCTIONS - Read all safety and operating instructions before the Drive is operated.

RETAIN INSTRUCTIONS - Retain the safety and operating instructions for future reference.

FOLLOW INSTRUCTIONS - Follow all operating and use instructions.

HEED WARNINGS - All warnings must be adhered to.

WATER AND MOISTURE - DO NOT use this product near water.

OVERLOADING - DO NOT overload wall outlets and extension cords. Doing so can result in fire or electric shock.

OBJECT AND LIQUID ENTRY - Never push objects of any kind into this product. Touching dangerous voltage points may cause a short resulting in fire or electric shock. Do not spill liquid of any kind on this product.

CONDENSATION - Moisture will form in the operating section of the product causing performance to be impaired if it is brought from cool surroundings into a warmer environment. If you are moving the unit to a location with a warmer temperature, let the product stand for 1-2 hours in the new location before turning it back on.

SERVICING - Do not attempt to repair this product yourself. Opening or removing covers may expose you to dangerous voltage or other hazards. Refer all servicing to qualified service personnel. (Refer to the enclosed Service and Support Card.)

A HARDWARE TOUR

REAR VIEW

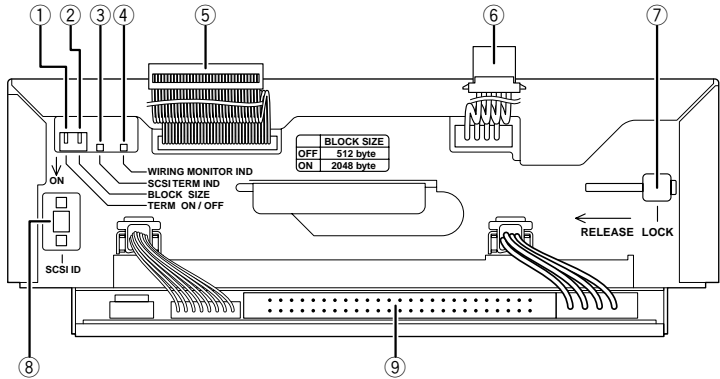

① SCSI termination switch

This switch is used to turn the drive's internal SCSI termination switch on and off. Note that this switch is set on at the time of shipment.

② Data block size switch

This switch is used to set the data block size. When this switch is turned on the data block size is set to a length of 2048 bytes, and when it is set off the data block size is set to a length of 512 bytes.

③ Termination indicator

When the drive is installed in a changer and its power cable has been connected, this indicator lights up if the drive's SCSI termination switch has been turned on.

④ Wiring monitor indicator

Meaning of indicator when indicator is lit up:

- Indicates that a disc has been inserted into the drive.
- This indicator also lights up when the drive is installed in a changer and its power cable has been connected.

Meaning of indicator when indicator flashes in 2-second intervals:

- This indicator flashes in 2-second intervals when the drive is installed in a changer and its changer interface cable has been connected.

Meaning of indicator when indicator flashes in 0.5-second intervals:

- This indicator flashes in 0.5-second intervals when the drive in question has

been specified as the drive to be swapped during the swapping of drives.

⑤ Changer interface cable

This cable must be connected to the changer-internal changer interface connector.

⑥ Power cable

This cable must be connected to the power inlet located in the changer.

⑦ Lock lever

When a drive is to be removed from the changer, flip the lock lever to the released position and then pull the drive out from the changer.

⑧ SCSI ID switches

These switches are used to set the drive's SCSI ID. Pressing the upper switch causes the displayed SCSI ID to be decremented, and pressing the lower switch conversely causes the SCSI ID to be incremented. Note that SCSI ID is set to '0' at the time of shipment.

⑨ SCSI interface connector

This connector must be connected to the SCSI cable provided with the changer or to an add-on SCSI cable.

NOTE:

Be careful not to allow any part of your body to come into contact with connector pins, as doing so may result in faulty connections or damage from static electricity.

A HARDWARE TOUR

TOP VIEW

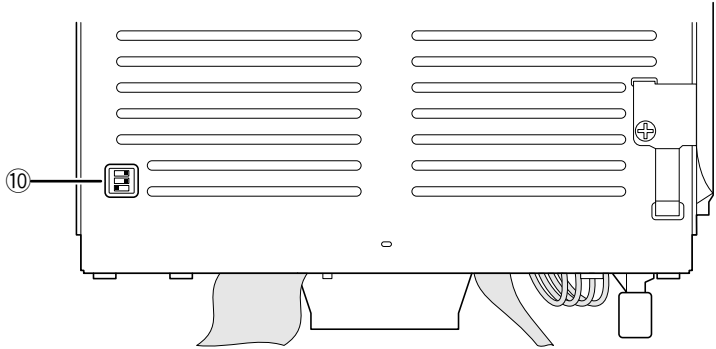

10 Function switch

ON OFF



This switch is used to check the device before shipment, and its setting should never be changed.

RPC (Region Play Control) Set switch

ON = Stay in RPC Phase I mode

OFF = Start RPC Phase II mode (Never return to Phase I mode after Phase II mode is used)

- Set ON at the time of shipping from the plant.
- For a DVD Video playback system (computer) for Phase I, please use with Phase I. When the DVD Video playback system (computer) and the drive have different region codes, DVD Video playback is not possible.

Set the jumper switch to OFF only when use of a drive corresponding to Phase II has been specified clearly for the DVD Video playback system (computer). The drive will be initialized automatically and will operate in Phase II mode.

TO INSTALL THE DRIVE

For instructions on how to open the access doors, see the operating instructions for the DRM-7000 disc changer.

Before installation, be sure to specify the following settings at the rear of each drive to be installed.

● SCSI ID assignment

Specify the SCSI IDs to be used so as to ensure that the same SCSI ID is not assigned by more than one drive on the same SCSI bus.

● Termination

Set the termination switch of the last drive in the SCSI chain to the ON position.

Warning about static electricity

Always be sure never to touch the contacts or ports when operating drives.

Also be sure to touch a metallic surface on the changer before installing additional drives to the changer.

1. When inserting a drive, be sure to place the drive on the changer guide rails and push the drive in until the lock lever on the drive shifts to the locked position. Maybe you can hear a clicking sound then.

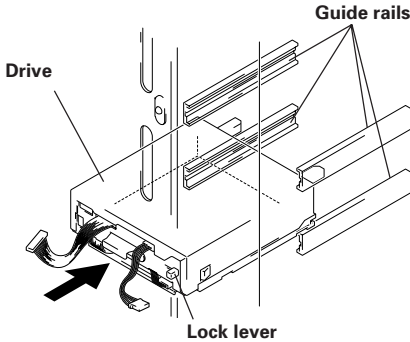

When a drive is to be removed from the changer, flip the lock lever to the released position and then pull the drive out from the changer.

2. Connect the power cable.

- When the power cable has been connected, the wiring monitor indicator on the rear of the drives (orange) will light up.
- When the termination switch of the drive is set to on, the termination indicator (green) will light up.

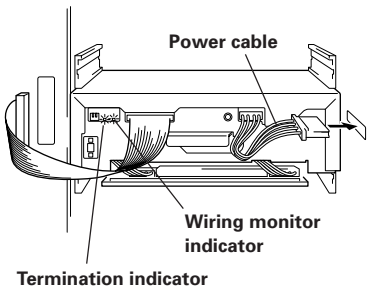

3. Connect the changer interface cable.

- When the changer interface cable has been connected, the wiring monitor indicators will flash at two-second intervals.

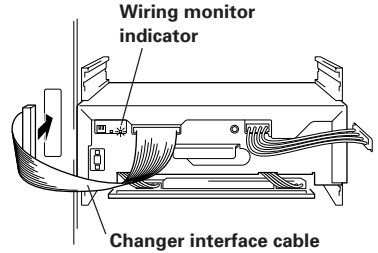

NOTE:

Connect the changer interface cable to the connector corresponding to the bay in which the drives have been installed. (Note that labels are affixed to connectors indicating the corresponding bay number.) Note that it is extremely important to do this, as connecting the changer interface cable to a neighboring bay will result in damage to discs and the disc transport mechanism.

4. Connect SCSI cables.

The way in which SCSI cables should be connected differs depending on how the changer is to be configured. For further information on how to connect SCSI cables, see the operating instructions for the DRM-7000 disc changer.

SPECIFICATIONS

[General functions]

Disc diameter	12 cm
Transfer rate (Sustained)	
DVD-ROM	maximum 8,100 kBytes/sec.*
CD-ROM	maximum 4,800 kBytes/sec.*
* The data transfer rate may not be output due to disc conditions (scratches, etc.).	
Access time (Random average)	
DVD-ROM	120 ms
CD-ROM	90 ms
Data buffer capacity	512 kBytes

[Others]

Power supply	DC +12 V, 1.0 A DC +5 V, 1.0 A
External dimensions	187.2 (W) x 72.4 (H) x 260.7 (D) mm
Weight	1.8 kg
Operation temperature	+5 °C to +35 °C
Operation humidity	5 % to 85 % (no condensation)
Storage temperature	-40 °C to +60 °C
Storage humidity	5 % to 90 % (no condensation)

NOTE:

Specifications and design subject to possible modifications without notice, due to improvements.

AFTER-SALES SERVICE FOR PIONEER PRODUCTS

Please contact the dealer or distributor from where you purchased the product for its after-sales service (including warranty conditions) or any other information. In case the necessary information is not available, please contact the Pioneer's subsidiaries (regional service headquarters) listed below:

PLEASE DO NOT SHIP YOUR PRODUCT TO THE COMPANIES

at the addresses listed below for repair without advance contact, for these companies are not repair locations.

AMERICA

PIONEER ELECTRONICS SERVICE, INC.
CUSTOMER SUPPORT DIVISION
P.O. BOX 1760, LONG BEACH, CA 90801-1760, U.S.A.

EUROPE

PIONEER ELECTRONIC (EUROPE) N.V.
EUROPEAN SERVICE DIVISION
HAVEN 1087, KEETBERGLAAN 1, 9120 MELSELE, BELGIUM

ASEAN

PIONEER ELECTRONICS ASIACENTRE PET. LTD.
SERVICE DEPARTMENT
501 ORCHARD ROAD, #10-00
WHEELLOCK PLACE, SINGAPORE 238880

JAPAN AND OTHERS

PIONEER ELECTRONIC CORPORATION (HEAD OFFICE)
CUSTOMER SUPPORT CENTER
4-1, MEGURO 1-CHOME, MEGURO-KU, TOKYO 153-8654 JAPAN



この取扱説明書はエコマーク認定
の再生紙を使用しています。

© 1999 パイオニア株式会社 禁無断転載

France : tapez 36 15 PIONEER

Published by Pioneer Electronic Corporation.
Copyright © 1999 Pioneer Electronic Corporation.
All rights reserved.

パイオニア株式会社 ☎ 153-8654 東京都目黒区目黒 1 丁目 4 番 1 号

PIONEER ELECTRONIC CORPORATION 4-1, Meguro 1-Chome, Meguro-ku, Tokyo 153-8654, Japan

Business System Company: 15-5, Ohmorinishi 4-Chome, Ohta-ku, Tokyo 143-8564 Japan TEL: 81-3-3763-2369

PIONEER NEW MEDIA TECHNOLOGIES, INC.

Laser Optical Systems Division: 2265 East 220th Street, Long Beach, CA 90810, U.S.A. TEL: 1-310-952-2111

PIONEER ELECTRONIC [EUROPE] N.V.

PIONEER House, Hollybush Hill, STOKE POGES, SLOUCH SL2 4QP U.K. TEL: 44-1753-789-789

PIONEER ELECTRONICS OF CANADA, INC.

Industrial Products Department: 300 Allstate Parkway, Markham, Ontario L3R 0P2, Canada TEL: 905-479-4411

PIONEER ELECTRONICS AUSTRALIA PTY. LTD.

178-184 Boundary Road, Braeside, Victoria 3195, Australia TEL: 61-3-9586-6300

PIONEER ELECTRONICS ASIACENTRE PTE. LTD.

501 Orchard Road, #10-00, Wheelock Place, Singapore 238880 TEL: 65-735-9011