

ECH₂O

Soil Moisture Sensor

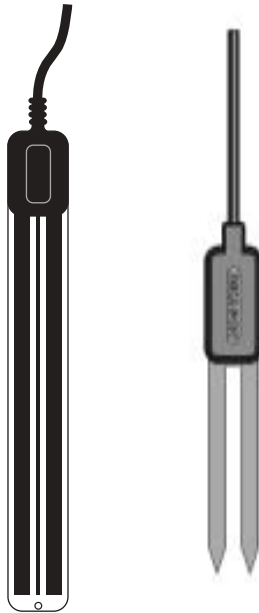

Operator's
Manual

For Models EC-20, EC-10, and EC-5

Version 5



Decagon Devices, Inc.
2365 NE Hopkins Court
Pullman WA 99163 USA

Trademarks:
"ECH₂O" is a registered trademark
of Decagon, Devices, Inc All rights reserved..

©2006 Decagon Devices, Inc.
All rights reserved.

10371-05

Contents

1. Introduction	1
Welcome	1
Specifications	1
Contact Information	2
Warranty Information	2
Seller's Liability	2
2. About the ECH ₂ O Probes	4
The EC-10 and EC-20	4
The EC-5	4
Probe Features	5
Wiring Diagrams	5
3.5mm plug wiring	5
Wiring to Non-Decagon Dataloggers ..	6
Extension cables	7
3. Installing the Probes	8
Procedure	8
Orientation	10
Removing the Probe	10
4. Collecting Data	11
Datalogger Requirements	11
Connecting to a Datalogger	12
Sample Program	12
SCWin (Short Cut) Directions	14
Calibration	15
Probe calibration values	16

Troubleshooting	19
Declaration of Conformity	20
Index	21

1. Introduction

Welcome

Welcome to the ECH₂O Dielectric Aquameter sensors for measuring soil water content. These innovative sensors will enable you to monitor soil moisture accurately and affordably.

Specifications

Measurement Time: 10ms (milliseconds)

Accuracy:

EC-10 and EC-20:

$\pm .04 \text{ m}^3/\text{m}^3 (\pm 4\%) < 0.5 \text{ dS/m}$

With soil-specific calibration: $\pm .02 \text{ m}^3/\text{m}^3 (\pm 2\%)$

EC-5:

at least $0.003 \text{ m}^3/\text{m}^3$ all soils, up to 8 dS/m

With soil-specific calibration: $\pm .02 \text{ m}^3/\text{m}^3 (\pm 2\%)$

Resolution:

EC-10 and EC-20: $0.002 \text{ m}^3/\text{m}^3$

EC-5: $0.001 \text{ m}^3/\text{m}^3$ VWC in mineral soils, 0.25% in growing media

Power:

Requirements:

EC-10 and EC-20: 2.5VDC @ 2mA to 5VDC @ 7mA

EC-5: 3VDC @ 10mA

Output: 10-40% of excitation voltage (250-1000mV at 2500mV excitation)

Operating Environment:

EC-10 and EC-20: 0 to 50°C

EC-5: -40 to +60 °C

Range of Measurement:

EC-10 and EC-20: 0 to saturated VWC

EC-5: 0 to 100% VWC

Probe dimensions:

EC-20: 25.4cm x 3.17cm x .15cm

EC-10: 14.5cm x 3.17cm x .15cm

EC-5: 8.9cm x 1.8cm x 0.7cm

Cable length: 5m standard, extension cable available

Connector types: 3.5 mm plug or stripped and tinned lead wires

Datalogger Compatibility (not exclusive):

Decagon: Em5, Em50 (and radio-enabled versions)

Campbell Scientific: CR10X, 21X, 23X, CR1000, CR3000, etc.

Contact Information

To contact Decagon for customer support or questions:

E-mail:

echo@decagon.com

Fax:

(509) 332-5158

Telephone:

(US and Canada only) 1-800-755-2751, or 509-332-2756.

Warranty Information

The ECH₂O probes have a 30-day satisfaction guarantee and a one-year warranty.

Seller's Liability

Seller warrants new equipment of its own manufacture against defective workmanship and materials for a period

of one year from date of receipt of equipment (the results of ordinary wear and tear, neglect, misuse, accident and excessive deterioration due to corrosion from any cause are not to be considered a defect); but Seller's liability for defective parts shall in no event exceed the furnishing of replacement parts F.O.B. the factory where originally manufactured. Material and equipment covered hereby which is not manufactured by Seller shall be covered only by the warranty of its manufacturer. Seller shall not be liable to Buyer for loss, damage or injuries to persons (including death), or to property or things of whatsoever kind (including, but not without limitation, loss of anticipated profits), occasioned by or arising out of the installation, operation, use, misuse, nonuse, repair, or replacement of said material and equipment, or out of the use of any method or process for which the same may be employed. The use of this equipment constitutes Buyer's acceptance of the terms set forth in this warranty. There are no understandings, representations, or warranties of any kind, express, implied, statutory or otherwise (including, but without limitation, the implied warranties of merchantability and fitness for a particular purpose), not expressly set forth herein.

2. About the ECH₂O Probes

The EC-10 and EC-20

The ECH₂O probe measures the dielectric constant of the soil in order to find its volumetric water content. Since the dielectric constant of water is much higher than that of air or soil minerals, the dielectric constant of the soil is a sensitive measure of water content. The ECH₂O probe has a very low power requirement and high resolution. This gives you the ability to make as many measurements as you want (even hourly) over a long period of time (like a growing season, for example), with minimal battery usage.

The EC-5

The EC-5 varies from its EC-10 and EC-20 cousins. Although the principles of measurement are the same, its two-prong design and higher measurement frequency allows the EC-5 to measure VWC from 0 to 100%, and allows accurate measurement of all soil types and a much wider range of salinities.

Probe Features

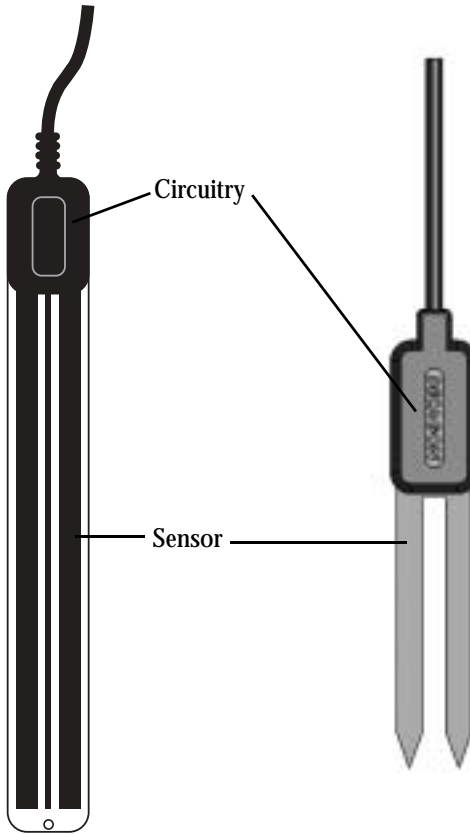

Fig. 1: ECH₂O probe diagram *Fig. 2: EC-5 probe diagram*

Wiring Diagrams

3.5mm plug wiring

The ECH₂O probe comes with a 3.5mm “stereo plug” connector. This allows for rapid connection directly to Decagon’s Em50 and Em5 logger to the ECH₂O Check.

Below is a diagram showing the wiring configuration for this connector.

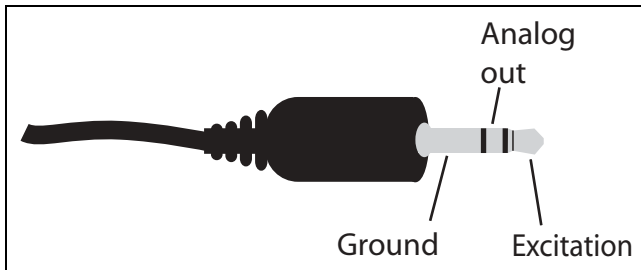

Fig. 2: ECH₂O plug wiring configuration

Wiring to Non-Decagon Dataloggers

Models with stripped and tinned leads are pre-configured for connecting to non-Decagon dataloggers. Simply wire the lead into the datalogger as described in “Connecting to a Datalogger” in Chapter 4.

If your model uses the standard 3.5mm plug, you have two choices when attaching ECH₂O probes to non-Decagon dataloggers. First, you can clip off the plug on the probe cable, strip and tin the wires, and wire it directly into the datalogger. This has the advantage of creating a direct connection with no chance of the probe becoming un-plugged; however, it then cannot be used in the future with a Decagon Em50 or Em5 logger. The other choice is to obtain an ECH₂O adapter cable from Decagon. The 3-wire probe adapter cable has a connector for the ECH₂O probe jack on one end, and three wires on the other end for connection to a datalogger (this type of wire is often referred to as a “pigtail” adapter). Both the probe wire and adapter cable wire have the same wire output (shown in

Fig. 3); the white wire is excitation, red is output, and the bare wire is ground.

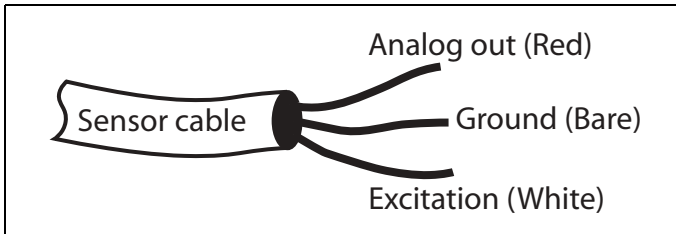

Fig. 3: 3-wire cable wiring configuration

Extension cables

Decagon supplies 50-foot (15.25m) and 10-foot (3m) extension cables for use with the ECH₂O probe. You can safely connect up to 4 of the 50-foot cables without signal attenuation. For most applications, you will want to seal the connections from the elements to maintain a good connection and to prevent corrosion.

3. Installing the Probes

When selecting a site for installation, it is important to remember that the soil adjacent to the probe surface has the strongest influence on the probe reading and that the probe measures the *volumetric* water content. Therefore any air gaps or excessive soil compaction around the probe can profoundly influence the readings. Also, do not install the probes adjacent to large metal objects such as metal poles or stakes. This can attenuate the probe's electromagnetic field and adversely affect output readings. Because the EC-5 has gaps between its prongs, it is also important to consider the size of the media you are inserting the probe into. It is possible to get sticks, bark, roots or other material stuck between the probe prongs, which will adversely affect readings. Finally, be careful when inserting the probes into dense soil, as the prongs will break if excessive sideways force is used when pushing them in.

Procedure

When installing the ECH₂O probe, it is best to maximize contact between the probe and the soil. There are two methods to accomplish this.

For the EC-10/EC-20:

1. **(Recommended)** Use Decagon's Probe Installation Kit to install the probe. This kit has a custom-shaped blade to make the insertion in the soil, then another tool to place the probe into the insertion. For deeper installations, use an augur to reach the desired depth,

then use the Installation kit with extension rods to install the probe.

2. Use a thin implement like a trenching shovel, gardening spade, or flat bar to make a pilot hole in the soil. Then insert the probe into the hole, making sure the entire length of the probe is covered. Finally, insert the shovel again into the soil a few inches away from the probe, and gently force soil toward the probe to provide good contact between the probe and the soil. For deeper installation, excavate down to the level you wish to measure, then install the probe as described.

For the EC-5:

1. Insert the probes into the soil, making sure that the prongs are buried completely up to the black overmolding, as shown below.



The tip of each prong has been sharpened to make it easier to push the probe in - *be careful with the sharp tips!*
The probe may be difficult to insert into extremely

compact or dry soil. If you have difficulty inserting the probe, try loosening the soil somewhat or wetting the soil. ***Never pound it in!***

Orientation

The probe can be oriented in any direction. However, orienting the flat side perpendicular to the surface of the soil will minimize effects on downward water movement.

Removing the Probe

When removing the probe from the soil, ***do not pull it out of the soil by the cable!*** Doing so may break internal connections and make the probe unusable.

4. Collecting Data

Datalogger Requirements

The ECH₂O sensors are designed to work most efficiently with Decagon's 5-channel Em5, Em50 or our ECH₂O Check handheld readout. They can, however, be adapted for use with other dataloggers, such as those from Campbell Scientific, Inc., for example. The ECH₂O requires an excitation voltage in the range of 2 to 5 volts. It produces an output voltage that depends on the dielectric constant of the medium surrounding the probe, and ranges between 10 and 50% of the excitation voltage. Any datalogger which can produce a 2.5 to 5V excitation with approximately 10 millisecond duration and read a volt-level signal with 12-bit or better resolution should be compatible with the ECH₂O probes. For the EC-10 and EC-20 probes, the current requirement at 2.5V is around 2mA, and at 5V it is 7-8mA. For the EC-5, it is 10mA at 2.5V.

NOTE: ECH₂O probes are intended only for use with dataloggers and readout devices which can provide short excitation pulses, leaving the probes turned off most of the time. Continuous excitation not only wastes battery power, but may, under certain circumstances, cause the probe to exceed government specified limits on electromagnetic emissions.

NOTE: All Decagon readout devices use either a 2.5V or 3V excitation, so the remainder of the discussion assumes this as the excitation. If other voltages are used, adjustments to the calibration equations provided will be needed.

Connecting to a Datalogger

Connect the wires to the datalogger as shown, with the supply wire connected to the excitation, the analog out wire to an analog input, and the bare ground wire to ground:

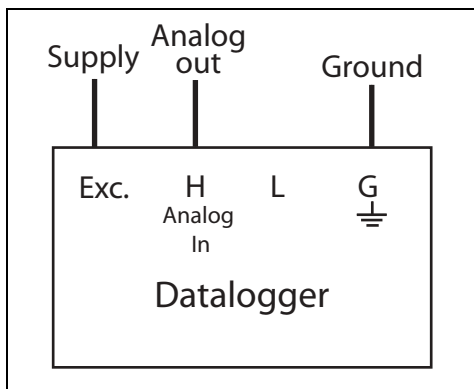

Fig. 5: Datalogger configuration

Sample Program

The following program is an example that can be used with Campbell Scientific's CR10X datalogger and our ECH₂O probes at a 2500mv excitation:

Important Note: Multiplier and offset in instruction 2 (P4) convert mV reading to % water content. Instruction 7 (P37) converts % volumetric water content to m³ m⁻³. Also, "--" (such as the one in

Instruction 4 (P89), line 1) increment the input location for the next time through the loop. A "--" is applied to the input location by clicking on the input location # and typing the letter "c".

```

;{CR10X}
; Example ECH2O Datalogger Program for CR10X

; Wiring:

; White: Excitation Channel 1
; Red: Input Single Ended Channel 1
; Black: Ground

*Table 1 Program
01: 1 Execution Interval (seconds)

; Factory calibration equations for ECH2O
; probes convert mV output of ECH2O to
; volumetric water content (VWC, m3/m3)

; EC-20: VWC = 0.00069 * mV - 0.29
; EC-10: VWC = 0.00093 * mV - 0.376
; EC-5: VWC = 0.00119 * mV - 0.400

; The multiplier and offset in this
; example are for the EC-5

1: Excite-Delay (SE) (P4)
1: 1 Reps
2: 5 2500 mV Slow Range
3: 1 SE Channel
4: 1 Excite all reps w/Exchan 1
5: 1 Delay (0.01 sec units)
6: 2500 mV Excitation
7: 1 Loc [ Probe_VWC ]
8: .00119 Multiplier
9: -.4 Offset

*Table 2 Program
02: 0.0000 Execution Interval (seconds)

*Table 3 Subroutines

End Program

1 [ Probe_VWC ] -W-- 0 1 -----
2 [ _____ ] ---- 0 0 -----
3 [ _____ ] ---- 0 0 -----
4 [ _____ ] ---- 0 0 -----
5 [ _____ ] ---- 0 0 -----
6 [ _____ ] ---- 0 0 -----
7 [ _____ ] ---- 0 0 -----
8 [ _____ ] ---- 0 0 -----
9 [ _____ ] ---- 0 0 -----
10 [ _____ ] ---- 0 0 -----
11 [ _____ ] ---- 0 0 -----

```

```

12 [ _____ ] ---- 0    0    -----
13 [ _____ ] ---- 0    0    -----
14 [ _____ ] ---- 0    0    -----
15 [ _____ ] ---- 0    0    -----
16 [ _____ ] ---- 0    0    -----
17 [ _____ ] ---- 0    0    -----
18 [ _____ ] ---- 0    0    -----
19 [ _____ ] ---- 0    0    -----
20 [ _____ ] ---- 0    0    -----
21 [ _____ ] ---- 0    0    -----
22 [ _____ ] ---- 0    0    -----
23 [ _____ ] ---- 0    0    -----
24 [ _____ ] ---- 0    0    -----
25 [ _____ ] ---- 0    0    -----
26 [ _____ ] ---- 0    0    -----
27 [ _____ ] ---- 0    0    -----
28 [ _____ ] ---- 0    0    -----

```

SCWin (Short Cut) Directions

Following are instructions for using our SCWin (Short Cut) program to read EC-5, EC-10 and EC-20 ECH₂O probes.

1. Download EchoCSI.zip from <http://www.deca-gon.com/appnotes/EchoCSIappnote.pdf>.
2. Unzip the folder EchoCSI.zip.
3. Locate the file containing SCWin.exe. It should be in C:\Program Files\Campbellsci\SCWin. Place the following files from the unzipped EchoCSI.zip folder into the folder with SCWin.exe:

AM1632Z.MUX

AM416Z.MUX

EC10.SCS

EC101632.SCS

EC10416.SCS

EC20.SCS

EC201632.SCS

EC20416.SCS

EC5.SCS

EC5632.SCS

EC5416.SCS
SCWIN-DECAGON.CNT
SCWIN-DECAGON.HLP

Note: If you are not able to find this directory path, search for the folder that contains SCWIN.exe and place the files into that folder.

4. Open up SCWin.exe (Short Cut). If you are using a V.3 copy of LoggerNet, there is a tab for SCWin (Short Cut) on the tool bar.
5. Select “New” to start a new program to read the ECH₂O probes.
 - a. Select the datalogger you will be using to read the probes.
 - b. Select the measurement interval (a shorter measurement interval, i.e. 1 sec., is sometimes desirable when testing the probes).
6. Click on Sensors (this should open a new page with a file tree on it).
7. Under the “Sensors” file tree, double-click on “Meteorological” and then select “Soil Moisture.”
8. ECH₂O Probe EC-10 and ECH₂O Probe EC-20 should appear on the tree along with other soil moisture probes.
 - a. If they don't appear, check to make sure you have pasted the files above into the correct location.

Calibration

The ECH₂O probes come pre-calibrated for most soil types. However, this general calibration may not be appli-

cable for all probes and all soil types. For example, the standard calibrations for the EC-20 and EC-10 probes do not perform in soils with high sand or salt content. Therefore, for added accuracy we encourage our customers to perform soil-specific calibrations.

The calibration equation that you will use depends on where you will be using it. If you will be using it with probes connected to a non-Decagon datalogger OR using the "SEN" value given from the ECH₂O Check, you will need to use the 2500 mV calibration. If you use any Decagon software (DataTrac, ECH₂O Utility, etc.) or the user calibration menu in the ECH₂O Check, you will need to use the RAW calibration. The difference between the two is the slope constant. To increase the resolution of the sensor output, Decagon uses all available increments of the 12-bit number (value of 4096) where the measurement is stored. Thus, the output of the sensors read by the ECH₂O Check and Decagon loggers must be multiplied by 0.61 AND the 2500 mV slope to give the right value.

Probe calibration values

Following is a list of the both the millivolt and RAW calibration values for the ECH₂O probes, where θ is the volumetric water content, mV is the millivolt output of the probe, and where x is the RAW probe output.

EC-20

$$2500mV: \theta (m^3/m^3) = 0.000695mV - 0.29$$

$$RAW: \theta (m^3/m^3) = 0.000424 x - 0.29$$

EC-10:

$$2500mV: \theta (m^3/m^3) = 0.000936mv - 0.376$$

$$\text{RAW: } \theta \text{ (m}^3\text{/m}^3\text{)} = 0.000571 x - 0.376$$

EC-5:

The EC-5 is much less sensitive to variation in texture and electrical conductivity because it runs at a much higher measurement frequency. Therefore, its general calibration equation should apply for all mineral soils up to 8 dS/m. Its calibration equations are shown below for mineral soil, potting soil, and rockwool growing media:

Mineral Soils

According to our tests, a single calibration equation will generally suffice for all mineral soil types with electrical conductivities from 0.1 dS/m to 10 dS/m. Volumetric water content (q) is given by

$$q = 8.5 * 10^{-4} * \text{Raw} - 0.48 \quad (1)$$

where Raw is the output from the Decagon datalogger. If you are using a non-Decagon datalogger, VWC is given by

$$q = 11.9 * 10^{-4} * mV - 0.401 \quad (2)$$

where mV is the output of the probe when excited at 2500 mV. Please note that the equation will reach a maximum at ~60% volumetric water content (VWC) in pure water. To display data on a scale from 0 to 100%, VWC should be modeled with a quadratic equation (which would result in a 100% VWC in water), but a linear equation fits the mineral soil VWC range as well as the quadratic, and linear equations are easier to deal with, especially since mineral soil typically saturates at ~40 - 50% VWC.

Potting soil

The following equations can be used to convert EC-5 output to water content in potting soil. We tested several types of potting soil (Sunshine mix, Miracle Grow Potting Mix, and Custom Nursery soil) at several salinities and found that VWC is given by

$$q = 7.2 * 10^{-4} * Raw - 0.393 \quad (3)$$

for a Decagon datalogger or

$$q = 10.3 * 10^{-4} * mV - 0.334 \quad (4)$$

for a datalogger with 2500mV excitation.

Rockwool

The EC-5 was calibrated in Grodan Master rockwool with solution electrical conductivities of 0.2, 1.0, 1.5, 2.0, and 4.5 dS/m. Volumetric water content can be calculated using

$$q = 6.28 * 10^{-7} * Raw^2 + 1.37 * 10^{-4} * Raw - 0.183 \quad (5)$$

for a Decagon datalogger or

$$q = 2.63 * 10^{-6} * mV^2 + 5.07 * 10^{-4} * mV - 0.0394 \quad (6)$$

for a datalogger with 2500 mV excitation.

NOTE: These calibration constants only apply to 2500mV excitations; use of these numbers with any other excitation voltage will result in erroneous readings!

Troubleshooting

If you encounter problems with the ECH₂O probes, they most likely will manifest themselves in the form of incorrect or erroneous readings. Before contacting Decagon about the sensor, do the following:

- Check to make sure the connections to the datalogger are both *correct* and *secure*.
- Ensure that your datalogger's batteries are not dead or weakened.

If you encounter problems that aren't due to the datalogger, please contact Decagon at (509) 332-2756 and at **echo@decagon.com**.

Declaration of Conformity

Application of Council Directive: 89/336/EE6

**Standards to which conformity
is declared:** EN61326 : 1998
EN51022 : 1998

Manufacturer's Name: Decagon Devices, Inc.
2365 NE Hopkins Court
Pullman, WA 99163 USA

Type of Equipment: ECH₂O dielectric soil
moisture probe.

Model Number: EC-10, EC-20, EC-5

Year of First Manufacture: 2001

This is to certify that the ECH₂O dielectric soil moisture probe, manufactured by Decagon Devices, Inc., a corporation based in Pullman, Washington, USA meets or exceeds the standards for CE compliance as per the Council Directives noted above. All instruments are built at the factory at Decagon and pertinent testing documentation is freely available for verification.

Index

A

accuracy 1

C

calibration

for EC-10 16

for EC-20 16

for EC-5 17

for mineral soil 17

for potting soil 18

for rockwool 18

contact information 2

D

datalogger 2

connecting to 12

requirements 11

sample program 12

declaration of conformity 20

E

EC-10 4

EC-20 4

EC-5 4

calibration 17

email 2

e-mail address 2

extension cables 7

I

installation 8

 procedure 8

 tips 8

M

measurement range 2

mineral soil

 calibration 17

O

orientation of probe 10

P

plug

 wiring configuration 5

potting soil 18

power

 requirements 1

probe

 calibration 15

 installation instructions 8

 orientation 10

 specifications 1

probe orientation 10

program 12

R

range 2

removing the probe 10

rockwool 18

S

seller's liability 2

Short Cut directions 14

specifications 1

T

troubleshooting 19

W

warranty 2

wiring diagram 5

wiring diagrams 5