

**POWERED DIRECT VENT SERIES GAS-FIRED
WATER HEATER**



A Spanish language version of these instructions is available by contacting the company listed on the rating plate.

La version espanola de estas instrucciones se puede obtener al escribirle a la fabrica cuyo nombre aparece en la placa de especificaciones.

**PDX INSTALLATION AND OPERATING
INSTRUCTION MANUAL**

WARNING: If the information in these instructions is not followed exactly, a fire or explosion may result causing property damage, personal injury or death.

FOR YOUR SAFETY

—Do not store or use gasoline or other flammable, combustible, or corrosive vapors and liquids in the vicinity of this or any other appliance.

— WHAT TO DO IF YOU SMELL GAS

- Do not try to light any appliance.
- Do not touch any electrical switch; do not use any phone in your building.
- Immediately call your gas supplier from a neighbor's phone. Follow the gas supplier's instructions.
- If you cannot reach your gas supplier, call the fire department.

— Installation and service must be performed by a qualified installer, service agency or the gas supplier.

For your family's comfort, safety and convenience we recommend Bradford White water heaters to be installed and serviced by a plumbing professional.

CONGRATULATIONS!

You have just purchased one of the finest water heaters on the market today!

This installation, operation and instruction manual will explain in detail the installation and maintenance of your new Powered Direct Vent Series Gas-Fired Residential Water Heater. We at Bradford White strongly recommend that you contact a plumbing professional for the installation of this water heater.

We require that you carefully read this manual, as well as the enclosed warranty, and refer to it when questions arise. If you have any specific questions concerning your warranty, please consult the plumbing professional from whom your water heater was purchased. For your records we recommend that you write the model, serial number and installation date of your water heater in the maintenance section in the back of this manual.

This manual should be kept with the water heater.

At Bradford White we're committed to providing you with

TABLE OF CONTENTS

	page
GENERAL INFORMATION.....	4
INSTALLATION.....	5
Locating The Water Heater.....	5
Minimum Clearances.....	8
Venting.....	8
Water Connections.....	22
Gas Connections.....	25
Electrical Connections.....	26
Wiring Diagram.....	27
GENERAL OPERATION.....	28
Lighting and Shutdown Instructions.....	29
Thermostat Adjustment.....	30
Burner Flame Check.....	31
MAINTENANCE.....	32
PARTS LIST AND DRAWING.....	35
BLOWER PARTS LIST AND DRAWING.....	36
INSTALLATION INSTRUCTIONS FOR POTABLE WATER AND SPACE HEATING.....	37
VENT PIPE PREPARATION AND JOINING.....	38
NOTES.....	40

GENERAL INFORMATION

This gas-fired water heater's design is certified by CSA International under the *American National Standard Z21.10.1* - (as indicated on the rating plate) and *CSA 4.1-M* - (as indicated on the rating plate).

This water heater must be installed in accordance with local codes or, in the absence of local codes, the *National Fuel Gas Code, ANSI Z223.1*-Latest Edition) and/or in Canada *CAN/CGA B149 Installation Codes* (Latest Editions). The warranty for this water heater is in effect only when the water heater is installed, adjusted, and operated in accordance with these Installation and Operating Instructions. The manufacturer will not be held liable for any damage resulting from alteration and/or failure to comply with these instructions.

This water heater is not design certified for installation in a mobile home. Such an installation may create a hazardous condition and will nullify the warranty.

CAUTION

Incorrect operation of this appliance may create a hazard to life and property and will nullify the warranty.

Do not use this appliance if any part has been submerged in water. You should contact a qualified service technician to inspect the appliance and to replace any part of the control system including the combination gas control, which has been submerged in water.

DANGER

Do not store or use gasoline or other flammable, combustible, or corrosive vapors and liquids in the vicinity of this or any other appliance.

IMPORTANT

Before proceeding, please inspect the water heater and its components for possible damage. **DO NOT** install any damaged components. If damage is evident then please contact the supplier where the water heater was purchased or the manufacturer listed on the rating plate for replacement parts.

Make sure that you check the rating plate and combination gas control on the water heater to be certain that the type of gas being supplied corresponds with the marking on the rating plate and combination gas control.

General Information continued

A sacrificial anode is used to extend tank life. The removal of this anode, for any reason, will nullify the warranty. In areas where water is unusually active, an odor may occur at the hot water faucet due to a reaction between the sacrificial anode and the impurities in the water. If this should happen, an alternative anode may be purchased from the supplier that installed this water heater. This will minimize the odor while protecting the tank. Additionally, the water heater should be flushed with appropriate dissolvers to eliminate any bacteria.

INSTALLATION

Locating The Water Heater

WARNING

Water heaters are heat-producing appliances. To avoid damage or injury, do not store materials against the water heater or vent-air intake system. Use proper care to avoid unnecessary contact (especially by children) with the water heater and vent-air intake components. **UNDER NO CIRCUMSTANCES MUST FLAMMABLE MATERIALS, SUCH AS GASOLINE OR PAINT THINNER BE USED OR STORED IN THE VICINITY OF THIS WATER HEATER, VENT-AIR INTAKE SYSTEM OR IN ANY LOCATION FROM WHICH FUMES COULD REACH THE WATER HEATER OR VENT-AIR INTAKE SYSTEM.**

DO NOT install the water heater in any location where gasoline or flammable vapors are likely to be present.

CAUTION

The National Fuel Gas Code (ANSI Z233.1-or latest edition) and CAN/CGA (B149.1-or latest edition), expressly prohibits the installation of a water heater in a garage, unless the unit is installed so that the burner and ignition devices are at least eighteen (18) inches (46 cm) above floor level and protected to avoid damage by a moving vehicle.

The location of this water heater is of the utmost importance. Before installing this water heater, read the installation section of these instructions. After reading these installation and operating instructions, select a location for the water heater where the floor is level and is easily accessible to gas and water supply lines. **DO NOT** locate the water heater where water lines could be subjected to freezing temperatures. Make sure the cold water pipes are not located directly above the gas control so that condensate during humid weather does not drip on the controls.

Installation (Locating The Water Heater) continued

Water heater corrosion and component failure can be caused by the heating and breakdown of airborne chemical vapors. Examples of some typical compounds that are potentially corrosive are: spray can propellants, cleaning solvents, refrigerator and air conditioning refrigerants, swimming pool chemicals, calcium and sodium chloride, waxes and process chemicals. These materials are corrosive at very low concentration levels with little or no odor to reveal their presence. **NOTE: DAMAGE TO THE WATER HEATER CAUSED BY EXPOSURE TO CORROSIVE VAPORS IS NOT COVERED BY THE WARRANTY. DO NOT OPERATE THE WATER HEATER IF EXPOSURE HAS OR WILL OCCUR. DO NOT STORE ANY POTENTIALLY CORROSIVE COMPOUNDS IN THE VICINITY OF THE WATER HEATER.**

▲ WARNING

Liquefied petroleum gases/propane gases are heavier than air and will remain at floor level if there is a leak. Basements, crawl spaces, closets and areas below ground level will serve as pockets for accumulation of leaking gas. Before lighting, smell all around the appliance area for gas. Be sure to smell next to the floor.

IF YOU SMELL GAS:

- **Do not try to light any appliance.**
- **Do not touch any electric switch; do not use any telephone in your building.**
- **Immediately call your gas supplier from a neighbor's telephone. Follow the gas supplier's instructions.**
- **If you cannot reach your gas supplier, call the fire department.**

DO NOT OPERATE APPLIANCE UNTIL THE LEAKAGE IS CORRECTED!

▲ WARNING

DO NOT ATTEMPT TO LIGHT ANY GAS APPLIANCE IF YOU ARE NOT CERTAIN OF THE FOLLOWING:

- **Liquefied petroleum gases/propane gas and natural gas have an odorant added by the gas supplier that aids in the detection of the gas.**
- **Most people recognize this odor as a “sulfur” or “rotten egg” smell.**
- **Other conditions, such as “odorant fade” can cause the odorant to diminish in intensity, or “fade”, and not be as readily detectable.**
- **If you have a diminished sense of smell, or are in any way unsure of the presence of gas, immediately contact your gas supplier from a neighbor’s telephone.**
- **Gas detectors are available. Contact your gas supplier, or plumbing professional, for more information.**

The water heater must be located close enough to the outside wall to keep the venting distance within the maximum distance described in the installation instructions. Read the venting section in this installation instruction manual before locating the water heater.

This water heater must be located in an area where leakage of the tank or water line connections and the combination temperature and pressure relief valve will not result in damage to the area adjacent to the water heater or to lower floors of the structure. When such locations cannot be avoided, a suitable drain pan adequately piped for proper drainage, must be installed under the water heater. The drain pan must be no greater than 1-½ inches (3.8 cm) deep and have a minimum length and width of at least four (4) inches (10.2 cm) measured from the jacket of the water heater. The drain pan, as described above, can be purchased from your plumbing professional. The drain pan must be piped to an adequate drain. The piping must be at least ¾ inch (1.9 cm) in diameter and pitched for proper drainage.

It is recommended that a minimum clearance of four (4) inches (10.2 cm) be provided on the side of the water heater for servicing and maintenance of the combination temperature and pressure relief valve.

Minimum Clearances

WARNING

Failure to adhere to these installation and operating instructions may create a hazard to life and property and will nullify the warranty.

This installation must allow access to the front of the water heater and adequate clearance must be provided for servicing and operating this water heater. The water heater may be installed on either a combustible or non-combustible floor. If the water heater is to be installed directly on carpeting, it must be installed on top of a metal or wood panel extending beyond the full width and depth of the appliance by at least three (3) inches (7.6 cm) in any direction or, if the appliance is to be installed in an alcove or closet, the entire floor must be covered by the panel. The minimum clearances to combustibles for this water heater is: zero (0) inches (0 cm) from the sides and rear, five (5) inches (12.7 cm) from the front of the jacket, zero (0) inches (0 cm) from the vent connector and fifteen (15) inches (38.1 cm) from the jacket top.

Venting

The National Fuel Gas Code ANSI Z223.1-(Latest Edition), CGA/CAN B149 Installation Code, and local codes have specific requirements for the location of the vent terminals on vertical walls. The guidelines listed below are from the National Fuel Gas Code. Consult the local codes, and/or National Fuel Gas Code ANSI Z223.1-(Latest Edition), or CGA/CAN B149 Installation Code to determine if there are any additions or changes to the following specifications.

- (A) The vent terminals must terminate at least 3 feet (.91 m) above any forced air inlet duct located within 10 feet (3 m). Exception: This provision shall not apply to the combustion air intake of a direct vent appliance.
- (B) The vent terminals must terminate at least 12 inches (.31 m) below, 12 inches (.31 m) horizontally from, or 12 inches (.31 m) above any door, window, or any gravity air inlet into the building.
- (C) The bottom of the vent terminal and the air intake shall be located at least 12 inches (.31 m) above grade.

Note: Must be installed in a location where it will not be blocked by snow.

- (D) The vent terminals must not terminate over a public walkway or over an area where condensate or vapor could create a nuisance or hazard or could be detrimental to the operation of regulators, relief valve, or other equipment.
- (E) The water heater location must provide easy access for the entire length of the vent connector.

Venting continued-

- (F) The vent system must be inspected at least once a year to ensure against leakage of exhaust products.

Exceptions For Installations in Canada:

- (A) The vent terminals must be located at least 1 foot (.31 m) from any window or door, which can be opened in any building, any non-mechanical air supply inlet to any building, or the combustion air inlet to any other appliance.
- (B) The vent terminals must be located at least 6 feet (1.8 m) from any mechanical air supply inlet to the building.
- (C) The vent terminals must not terminate above a meter/regulator assembly or within 3 feet (.91 m) horizontally of the vertical centerline of the regulator and must be at least 6 feet (1.8 m) from any gas service regulator vent outlet.
- (D) The vent terminals must be at least 7 feet (2.1 m) above a paved sidewalk or a paved driveway located on public property.
- (E) The vent terminals must not terminate above a paved sidewalk or a paved driveway, which is located on adjacent private property.
- (F) Underneath a verandah, porch or deck, unless:
- (1.) The verandah, porch or deck is fully open on a minimum of two sides beneath the floor, and
 - (2.) The distance between the top of the **vent-air intake** terminal and the underside of the verandah, porch or deck is greater than 1 ft (30.5 cm).

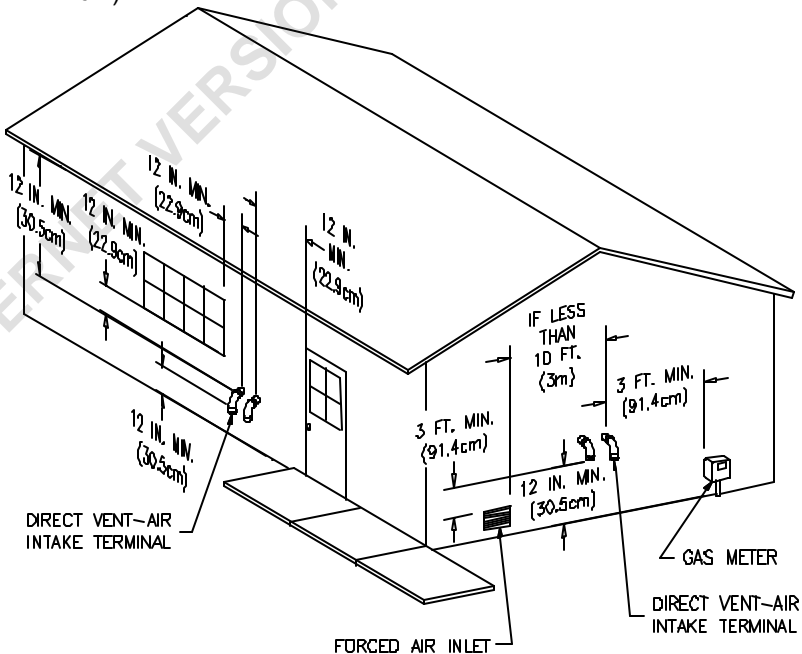

Venting continued-

Venting Installation Instructions For Supplied Intake Venting:

1. Refer to Figure 1, "Vent Assembly Illustration" to install intake venting as described below.
2. Insert one end of the Vertical Pipe into Metal Boot on the lower backside of the water heater.
3. Slide the Support Bracket over the Vertical Pipe, but do not fasten to the Jacket Head.
4. Position the Intake Tee on top of the Vertical Pipe so that the short straight section of the tee faces the Blower Intake Collar, and the curve of the tee faces upward. **Proper orientation of the curved section of the tee is critical. Be sure it is facing upward. Refer to "This End Up" label on Intake Tee.**
5. Slide the Rubber Intake Elbow over the Blower Intake Collar and over the short straight section of the Intake Tee.
6. Using a level to ensure that the Vertical Pipe is straight up and down, secure the Vertical Pipe to the Jacket Head using the Support Bracket and three (3) self-drilling screws provided. **NOTE: Correct vertical positioning of the Vertical Pipe is Important.**
7. After securing the Vertical Pipe to the Jacket Head with the Support Bracket, tighten the clamps on the Rubber Intake Elbow.
8. Using the RTV sealant provided, place a bead of RTV around the Vertical Pipe at the Metal Boot location, and at the Intake Tee location. Smooth out the RTV to provide a seal at both locations.
9. Two 90° end terminal elbows are supplied. These must be installed at the extreme ends of the intake and exhaust venting outside the building. The end terminal with the external screen must be installed on the intake vent as shown in Figure 7.
10. Proceed as necessary to complete the venting installation as described in the venting section of this manual.

Venting continued-

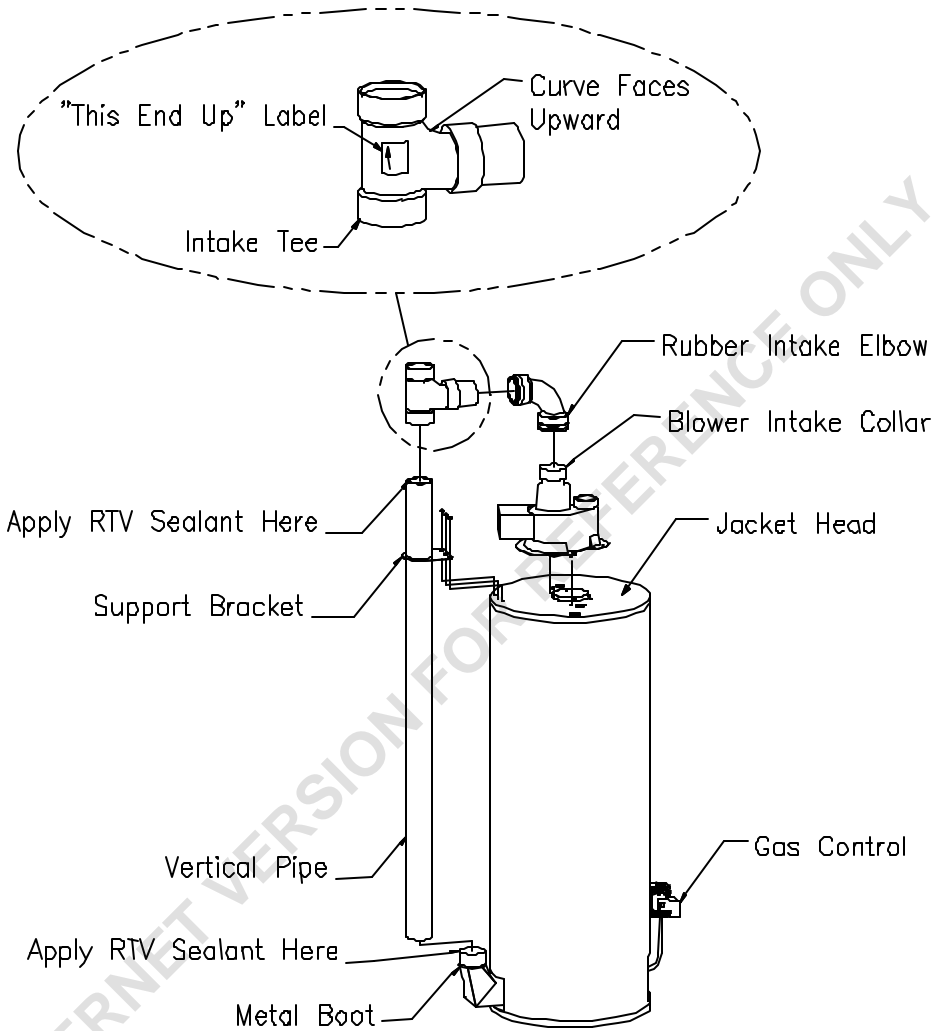

Figure 1
Vent Assembly Illustration

Venting continued-

Venting System Condensation

Condensate formation does not occur in all installations of power vented heaters, but should be protected against on installations where condensation can form in the venting system.

Formation of condensation in the venting system of Power Vented water heaters is dependent upon installation conditions including, but not limited to:

- ambient temperature and humidity of installation location;
- ambient temperature and humidity of venting space;
- vent distance and slope;
- and product usage.

In order to effectively control condensate from adversely affecting the mechanical components of the water heater several methods may be employed:

1. For horizontal installations the vent pipe can be installed with a downward slope (not less than 1/8" nor greater than 1/2" per foot maximum) and away from the blower motor.
2. In order to prevent condensate from draining back into the blower (vertical or horizontal runs), a fitting and drain hose is available as a condensate trap kit (see Table 1 for service part numbers). The all rubber fitting with drain outlet mounts directly to the blower motor outlet and is secured with two hose clamps (one to the blower motor outlet and the other to the vent connector). The plastic tubing is provided to drain any accumulated condensate away from the water heater and to a suitable drain. The kit comes complete with instructions for proper installation of the fitting.

Table 1	
Model	Service Part
2" (5.1 cm) Blower Outlet (exhaust)	239-42742-00
3" (7.6 cm) Blower Outlet (exhaust)	239-42743-00

Venting continued-

3. In order to prevent condensate from draining back into the blower (vertical or horizontal runs), a drain tee and condensate trap can be installed in the horizontal vent as close as practical to the blower vent connection (see Figure 2). The condensate disposal tube should be installed to drain any accumulated condensate away from the water heater and to a suitable drain. The drain tee and condensate hose are not available from Bradford White, but should be available through your local distributor.

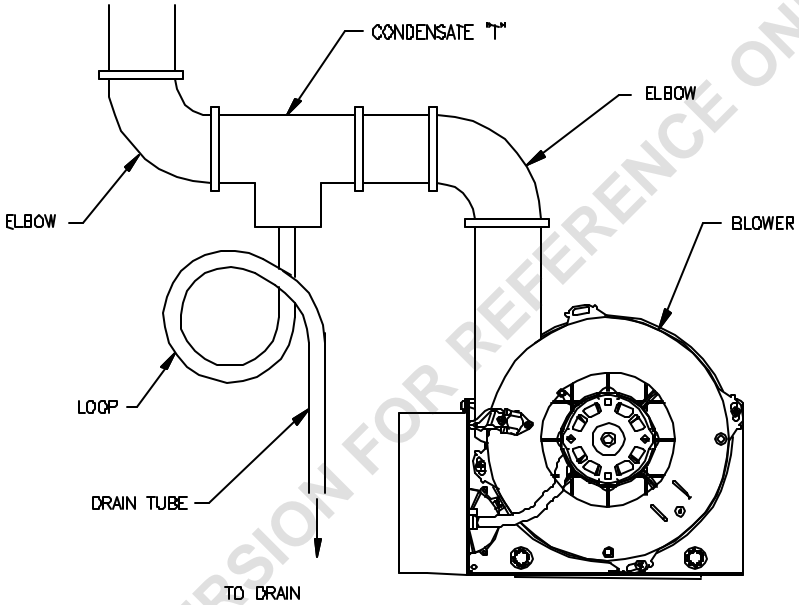

Figure 2

Venting continued-

This water heater is a power direct vented appliance and is designed to intake and exhaust its products of combustion through 3" (7.6 cm) or 4" (10.2 cm) diameter Schedule 40 PVC pipe to the outdoors. This water heater may intake and exhaust either through the wall or vertically through the roof. Use a 3" (7.6 cm) to 4" (10.2 cm) reducer to connect to the intake and outlet when using 4" (10.2 cm) PVC. Table 2 lists the maximum intake and exhaust lengths for this water heater using 3" (7.6 cm) PVC. If possible, locate the water heater so that the venting length and number of elbows are kept to the minimum distance necessary to reach the outside. If the installation requires venting lengths that exceed the lengths listed for 3" (7.6 cm) PVC in Table 2, then use 4" (10.2 cm) PVC for the vent connector. Table 3 lists the venting distances allowed with 4" (10.2 cm) diameter PVC pipe. When venting with 4" (10.2 cm) PVC, use a 4" (10.2 cm) to 3" (7.6 cm) reducer to exit through the building wall with 3" (7.6 cm) PVC. Use the 3" (7.6 cm) vent terminal supplied with the water heater to terminate on the outside of the building. If the length of the 3" (7.6 cm) PVC needed to go through the wall is greater than 14" (35.5 cm), use 4" (10.2 cm) PVC to go through the wall and reduce to 3" (7.6 cm) PVC immediately after exiting the outside wall. Refer to the venting illustrations on the following pages. Make sure the vent pipe terminal elbow fittings are at least 1" (2.5 cm) away from the edge of the wall.

To calculate total equivalent feet

Add up the total number of 90° elbows on the intake and the exhaust, and multiply by 5 feet (1.5 m) (each 90° elbow is equivalent to 5 feet (1.5 m) of straight pipe). To this number add the total number of feet of straight pipe on the intake and the exhaust. This sum (total of all 90° elbows at 5 feet (1.5 m) each, plus total number of feet of straight pipe) must not exceed 80 feet (24.4 m). All elbows must be included in the calculation except those on the extreme ends of the intake and exhaust. 45° elbows may also be used. When using 45° elbows, take the total number of 45° elbows on the intake and exhaust and multiply by 2 1/2 feet (.76 m) (each 45° elbow is equivalent to 2 1/2 feet (.76 m) of straight pipe).

Total equivalent feet=

(# of 90° elbows x 5) + (# of 45° elbows x 2 1/2) + (total feet of straight pipe)

Total equivalent meters=

(# of 90° elbows x 1.5) + (# of 45° elbows x .76) + (total meters of straight pipe)

Venting continued-

EXAMPLE: The exhaust has two 90° elbows and the intake has four 90° elbows. The total feet of straight pipe on the exhaust is 15 ft. (4.6 m) and the total feet of straight pipe on the intake is 20 ft (6.1 m).

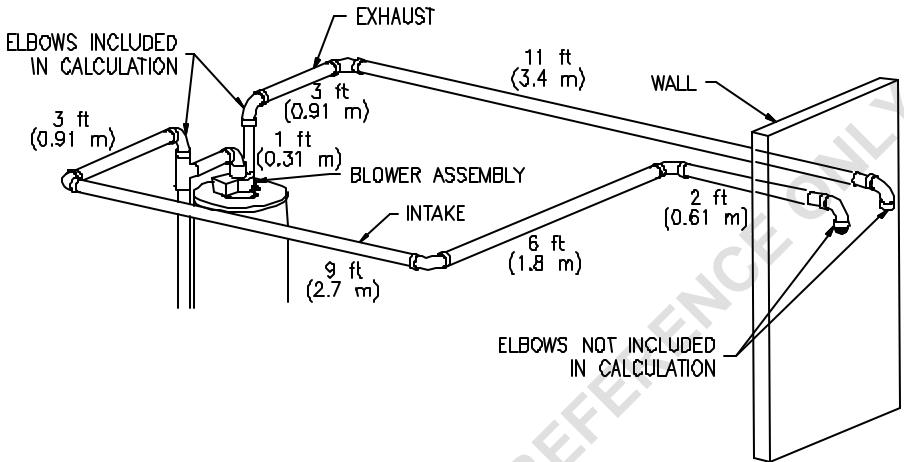

Figure 3

six 90° elbows x 5 ft. each = 30 ft
 Total straight pipe = 11 ft+3 ft+1 ft+3 ft+9 ft+6 ft+2 ft= 35 ft
 Total equivalent feet = 65 ft

Total straight pipe=3.4m+.91m+.31m+.91m+2.7m+1.8m+.61m = 10.6m
 six 90° elbows x 1.5 m each = 9.0m
 Total equivalent meters = 19.6m

IMPORTANT

For 3" (7.6 cm) vent piping, the total equivalent feet of venting (intake plus exhaust) must not exceed 80 feet (24.4 m) and the total equivalent feet of venting (intake or exhaust) must not exceed 40 feet (12.2 m). The total equivalent feet of intake must be within 20 feet (6.1 m) of the total equivalent feet of exhaust. See Table 2 for common 3" (7.6 cm) vent lengths.

For 4" (10.2 cm) vent piping, the total equivalent feet of venting (intake plus exhaust) must not exceed 150 feet (45.7 m) and the total equivalent feet of venting (intake or exhaust) must not exceed 75 feet (22.9 m). The total equivalent feet of intake must be within 20 feet (6.1 m) of the total equivalent feet of exhaust. See Table 3 for common 4" (10.1 cm) vent lengths.

Venting continued-

TABLE 2 - VENT CONNECTOR LENGTHS FOR 3" (7.6 cm) DIAMETER PVC	
Total # of 90° elbows (Intake + Exhaust)	Maximum # of feet of straight pipe (Intake + Exhaust)
2	70 (21.3 m)
3	65 (19.8 m)
4	60 (18.3 m)
5	55 (16.8 m)
6	50 (15.2 m)
7	45 (13.7 m)
8	40 (12.2 m)

TABLE 3 - VENT CONNECTOR LENGTHS FOR 4" (10.1 cm) DIAMETER PVC	
Total # of 90° elbows (Intake + Exhaust)	Maximum # of feet of straight pipe (Intake + Exhaust)
2	140 (42.7 m)
3	135 (41.1 m)
4	130 (39.6 m)
5	125 (38.1 m)
6	120 (36.6 m)
7	115 (35.1 m)
8	110 (33.5 m)

NOTE: When using 4" (10.1 cm) PVC, use a 4" (10.1 cm) to 3" (7.6 cm) reducer on the intake of the "Tee" as shown in Figure 4. When exiting the building wall, use another 4" (10.1 cm) to 3" (7.6 cm) reducer, and exit the wall with 3" (7.6 cm) PVC. If the length of 3" (7.6 cm) PVC needed to go through the wall is greater than 14" (35.5 cm), use 4" (10.1 cm) PVC to go through the wall and reduce to 3" (7.6 cm) PVC immediately after exiting the outside wall. Terminate the venting with the 3" (7.6 cm) vent terminals supplied, as shown in Figure 7.

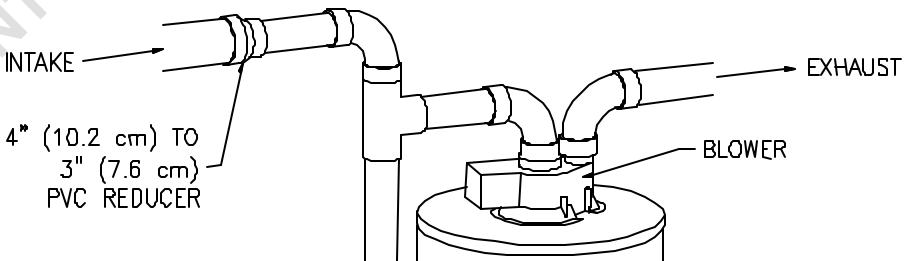

Figure 4

IMPORTANT

All of the Venting connections must be leak checked with a soap and water solution upon initial start up of the water heater. Any leaks must be repaired before continuing operation of the water heater.

NOTE: ABS or CPVC pipes may be substituted for PVC pipe. Do not mix ABS and PVC pipe in the same installation.

THROUGH THE WALL VENTING:

Cut a 3 1/2 in. (8.9 cm) diameter hole in the wall at the point where the vent connector is going to pass through the wall. Use the proper cement to secure the 90° vent terminal provided with the water heater to the vent connector. The distance between the edge of the 90° vent terminal and the exterior wall (see Figure 5) must be at least 1 in. (2.5 cm). The exhaust and intake terminals must not be less than 16 in. (40.6 cm) apart (see Figure 7). The exhaust terminal must not be mounted below the intake terminal. Use the proper cement and assembly procedures to secure the vent connector joints between the terminal and the blower outlet. Provide support brackets for every 3 feet (.91 m) of horizontal vent.

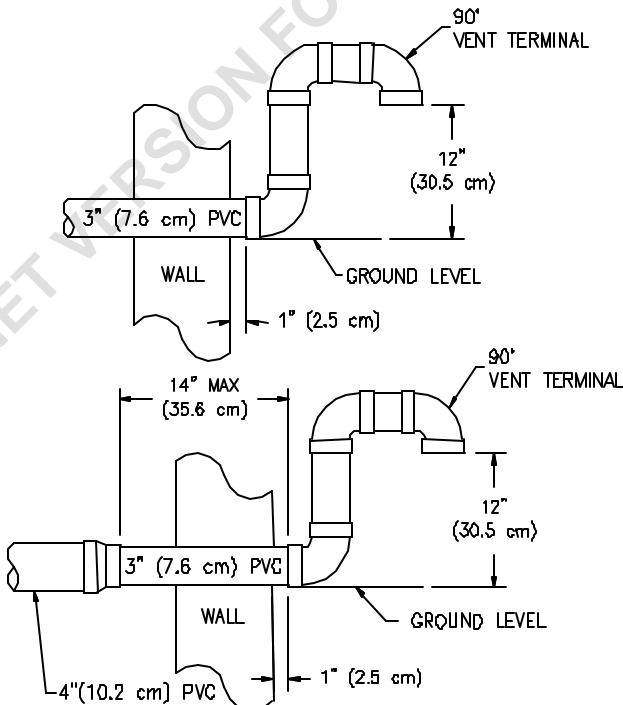

Figure 5

Venting continued-

THROUGH THE WALL VENTING WITH LOW GROUND CLEARANCE:

When venting cannot exit through the wall at a height greater than or equal to 12" (30.5 cm) above the ground or anticipated snow level, the installation must be modified as shown below (see Figure 6). Refer to Table 4 for maximum venting lengths using 3" (7.6 cm) PVC or Table 5 for maximum lengths using 4" (10.1 cm) PVC.

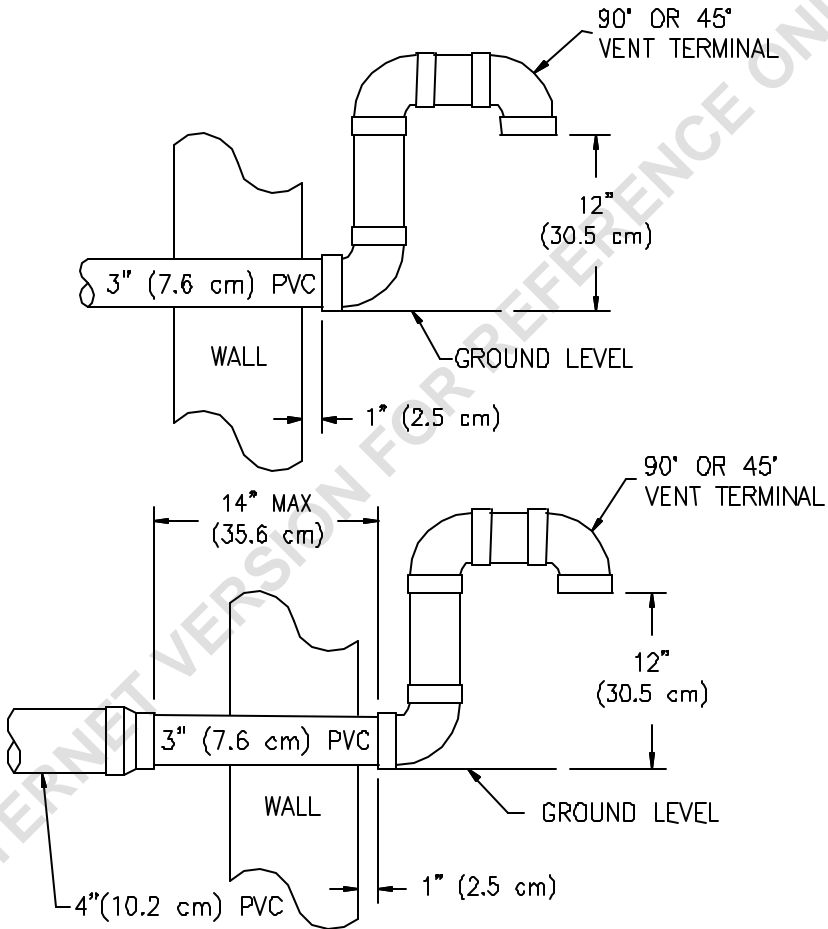

Figure 6

TABLE 4

3" (7.6 cm) PVC VENT CONNECTOR LENGTHS FROM INSIDE WALL FOR LOW GROUND CLEARANCE INSTALLATIONS

Terminating	# of Elbows (intake + exhaust)	Maximum # of Feet of Straight Pipe (intake + exhaust)
(2) 90° Elbows with (1) 90° Elbow	2	50 ft (15.2 m)
(2) 90° Elbows with (1) 90° Elbow	3	45 ft (13.7 m)
(2) 90° Elbows with (1) 90° Elbow	4	40 ft (12.2 m)
(2) 90° Elbows with (1) 90° Elbow	5	35 ft (10.7 m)
(2) 90° Elbows with (1) 90° Elbow	6	30 ft (9.1 m)
(2) 90° Elbows with (1) 90° Elbow	7	25 ft (7.6 m)
(2) 90° Elbows with (1) 90° Elbow	8	20 ft (6.1 m)

TABLE 5

4" (10.1 cm) VENT CONNECTOR LENGTHS FROM INSIDE WALL FOR LOW GROUND CLEARANCE INSTALLATIONS

Terminating (Reduce 4" to 3") (Reduce 10.1 cm to 7.6 cm)	#of Elbows (intake + exhaust)	Maximum # of Feet of Straight Pipe (intake + exhaust)
(2) 90° Elbows with (1) 90° Elbow	2	120 ft (36.6 m)
(2) 90° Elbows with (1) 90° Elbow	3	115 ft (35.1 m)
(2) 90° Elbows with (1) 90° Elbow	4	110 ft (33.5 m)
(2) 90° Elbows with (1) 90° Elbow	5	105 ft (32.0 m)
(2) 90° Elbows with (1) 90° Elbow	6	100 ft (30.5 m)
(2) 90° Elbows with (1) 90° Elbow	7	95 ft (29.0 m)

(2) 90° Elbows with (1) 90° Elbow	8	90 ft (27.5 m)
-----------------------------------	---	----------------

INTERNET VERSION FOR REFERENCE ONLY

Venting continued-

When venting through the wall, the exhaust terminal must exit the structure at a minimum of 16" (40.6 cm) from either side, or any location above the intake terminal. The exhaust terminal must not be located below the intake terminal for any reason (See Figure 7).

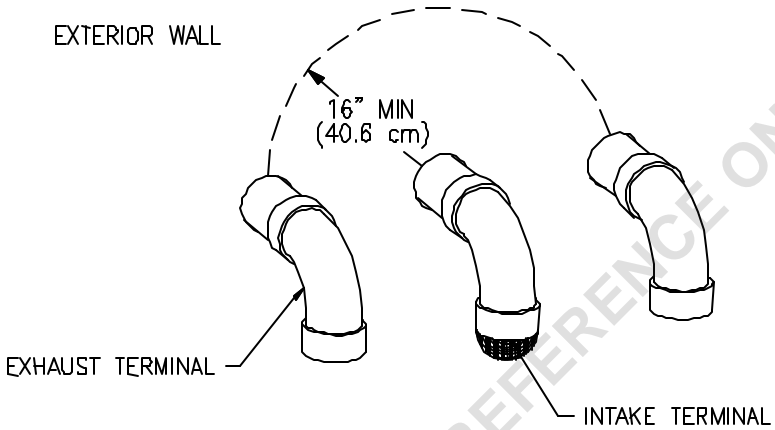

Figure 7

THROUGH THE ROOF VENTING: (VERTICAL VENTING)

Cut the necessary holes through the roof and ceiling and install the vent connector as shown in Figure 8. Make sure that the installation meets the local codes and/or The National Fuel Gas Code ANSI Z223.1 (Latest Edition) or CGA/CAN B149 Installation Code.

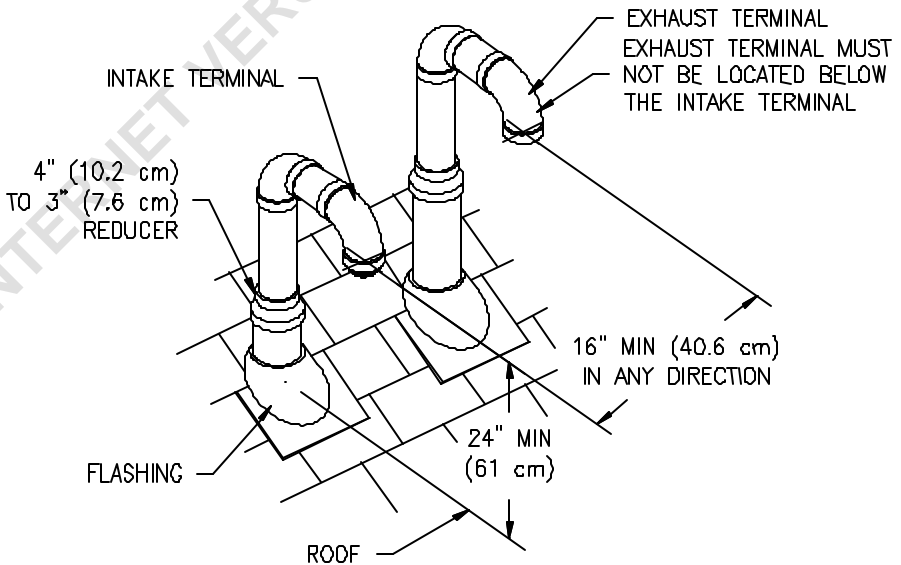

Figure 8

INTERNET VERSION FOR REFERENCE ONLY

Venting continued-

HIGH ALTITUDE INSTALLATIONS FOR ELEVATIONS OVER 2,000 FEET (914.5 m) ABOVE SEA LEVEL

The capacity of the induced draft blower declines with increasing altitude due to a reduction in the air density. In order to assure safe and reliable performance of the water heater, the following guidelines must be followed. Refer to the venting tables below for maximum distances for the altitudes in your location.

TABLE 6 - HIGH ALTITUDE LENGTHS

Altitude above sea level	Maximum venting length reduction from tables 2 & 4	Maximum venting length reduction from tables 3 & 5	Modifications to water heater
0-2,000 ft (0-609 m)	No reduction in vent length required	No reduction in vent length required	None
over 2,000-10,000 ft (609-3048 m)	No reduction in vent length required	No reduction in vent length required	Requires high altitude kit. Call the supplier or the manufacturer

Water Connections

Note: BEFORE PROCEEDING WITH THE INSTALLATION, CLOSE THE MAIN WATER SUPPLY VALVE.

After shutting off the main water supply, open a faucet to relieve the water line pressure to prevent any water from leaking out of the pipes while making the water connections to the water heater. After the pressure has been relieved, close the faucet. The COLD water inlet and HOT water outlet are identified on the top of the water heater. The fittings at the cold-water inlet and hot water outlet are dielectric waterway fittings with 3/4" (1.9 cm) NPT male thread. Make the proper plumbing connections between the water heater and the plumbing system to the house. Install a shut-off valve in the cold water supply line.

CAUTION

If sweat fittings are to be used **DO NOT** apply heat to the nipples on top of the water heater. Sweat the tubing to the adapter before fitting the adapter to the water connections. It is imperative that heat is not applied to the nipples containing a plastic liner.

WARNING

FAILURE TO INSTALL AND MAINTAIN A NEW, LISTED 3/4" X 3/4" TEMPERATURE AND PRESSURE RELIEF VALVE WILL RELEASE THE MANUFACTURER FROM ANY CLAIM, WHICH MIGHT RESULT FROM EXCESSIVE TEMPERATURE AND PRESSURES.

If this water heater is installed in a closed water supply system, such as one having a back-flow preventer in the cold water supply, provisions must be made to control thermal expansion. **DO NOT** operate this water heater in a closed system without provisions for controlling thermal expansion. Your water supplier or local plumbing inspector should be contacted on how to control this situation

After installation of the water lines, open the main water supply valve and fill the water heater. While the water heater is filling, open several hot water faucets to allow air to escape from the water system. When a steady stream of water flows through the faucets, close them and check all water connections for possible leaks. **NEVER OPERATE THE WATER HEATER WITHOUT FIRST BEING CERTAIN IT IS FILLED WITH WATER.**

▲WARNING

For protection against excessive temperatures and pressure, install temperature and pressure protective equipment required by local codes, but not less than a combination temperature and pressure relief valve certified by a nationally recognized testing laboratory that maintains periodic inspection of production of listed equipment or materials as meeting the requirements of the Standard for *Relief Valves and Automatic Gas Shutoff Devices for Hot Water Supply Systems, ANS Z21.22* or the Standard *CAN1-4.4, Temperature and Pressure Relief Valves and Vacuum Relief Valves*. The combination temperature and pressure relief valve must be marked with a maximum set pressure not to exceed the maximum working pressure of the water heater. The combination temperature and pressure relief valve must also have an hourly rated temperature steam BTU discharge capacity not less than the hourly rating of the water heater.

Install the combination temperature and pressure relief valve into the opening provided and marked for this purpose on the water heater.

Note: Some models may already be equipped or supplied with a combination temperature and pressure relief valve. Verify that the combination temperature and pressure relief valve complies with local codes. If the combination temperature and pressure relief valve does not comply with local codes, replace it with one that does. Follow the installation instructions above on this page.

Install a discharge line so that water discharged from the combination temperature and pressure relief valve will exit within six (6) inches (15.2 cm) above, or any distance below the structural floor and cannot contact any live electrical part. The discharge line is to be installed to allow for complete drainage of both the combination temperature and pressure relief valve and the discharge line. The discharge opening must not be subjected to blockage or freezing. **DO NOT** thread, plug or cap the discharge line. It is recommended that a minimum clearance of four (4) inches (10.2 cm) be provided on the side of the water heater for servicing and maintenance of the combination temperature and pressure relief valve.

Do not place a valve between the combination temperature and pressure relief valve and the tank.

▲WARNING

Hydrogen gas can be produced in an operating water heater that has not had water drawn from the tank for a long period of time (generally two weeks or more). Hydrogen gas is extremely flammable. To prevent the possibility of injury under these conditions, we recommend the hot water faucet to be open for several minutes at the kitchen sink before you use any electrical appliance, which is connected to the hot water system. If hydrogen is present, there will be an unusual sound such as air escaping through the pipes as hot water begins to flow. Do not smoke or have open flame near the faucet at the time it is open.

This water heater can deliver scalding temperature water at any faucet in the system. Be careful whenever using hot water to avoid scalding injury. Certain appliances such as dishwashers and automatic clothes washers may require increased temperature water. By setting the thermostat on this water heater to obtain the increased temperature water required by these appliances, you may create the potential for scald injury. To protect against injury, you should install an ASSE approved mixing valve in the water system. This valve will reduce point of discharge temperature by mixing cold and hot water in branch supply lines. Such valves are available from the manufacturer of this water heater or a local plumbing supplier. Please consult with a plumbing professional.

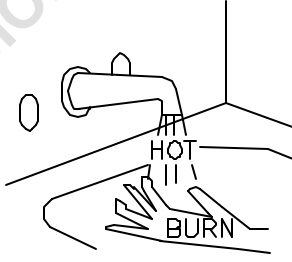
<p>▲ DANGER</p> 
<p>Water temperatures over 125°F (51.7°C) can cause severe burns instantly or death from scalds.</p> <p>Children, disabled, and elderly are at highest risk of being scalded.</p> <p>See instruction manual before setting thermostat at water heater</p> <p>Feel water before bathing or showering</p> <p>Temperature limiting valves are available.</p>

Gas Connections

The gas supply lines must meet all requirements of the National Fuel Gas Code ANSI Z223.1-(Latest Edition) and/or in Canada CAN/CGA B149 Installation Codes - (Latest Editions).

The minimum permissible gas supply pressure for the purpose of input adjustment is 1.5" water column (.37 kPa) above the operating manifold pressure for natural gas and 1.0" (.25 kPa) water column for L.P. gas. See the rating plate and combination gas control for the manifold pressure and gas type. The maximum permissible gas supply pressure is 14.0" water column (3.5 kPa) for natural gas and liquefied petroleum gases/propane gas.

1. Connect this water heater only to the type of gas (Natural or Propane gas) as shown on the rating plate. Use clean 1/2 inch (1.3 cm) black iron pipe. (Dirt and scale from the pipe can enter the combination control and cause it to malfunction). The inlet gas line must have a minimum length of 3" (7.6 cm) drip leg (*sediment trap*) installed as close to the water heater's combination gas control as possible. A ground joint union must be installed in the gas supply line feeding the water heater to permit servicing of the water heater. Compounds used on the threaded joints of the gas piping must be resistant to the action of liquefied petroleum gases/propane gas.
2. This water heater and its gas connection must be leak tested before placing the water heater in operation. Check for gas leaks with a soap and water solution and a brush or a commercial leak detector fluid. **NEVER USE A MATCH OR OPEN FLAME FOR TESTING!**

CAUTION

The water heater and individual shutoff valve must be disconnected from the gas supply piping system during any pressure testing of the system at test pressures in excess of 1/2 psi (3.5 kPa). The water heater must be isolated from the gas supply piping system by closing its manual shutoff valve during any pressure testing of the gas supply system at test pressures equal to or less than 1/2 psi (3.5 kPa). The supply line must be capped when not connected to the water heater.

3. While checking for leaks care must be taken to prevent solution from contacting the electrical connections at the control. If electrical connections at the control become wet, they must be thoroughly dried before attempting to operate the water heater.

Electrical Connections

All electrical wiring and connections must be in accordance with the National Electric Code ANSI/NFPA No. 70 (latest edition), or the Canadian Electrical Code C22.1 (latest edition) and any local codes, which may apply. The water heater must be electrically grounded.

If a flexible line cord and plug is permitted by local code, then provide a (3) three wire grounding type receptacle within 6 feet (1.9 m) of the water heater and use the flexible cord provided. Do not plug the line cord into a receptacle that can have the power supply interrupted by a switch that is used to turn on and off lights.

If wiring in conduit is required, remove the flexible line cord from the jacket and install a 1/2" (1.3 cm) electrical conduit connector and connect a 110/120-volt power source. Connect the hot, neutral, and ground leads of the electrical supply to the corresponding locations that were connected to the flexible line cord.

CAUTION

Turn off or disconnect the electrical power supply to the water heater before servicing. Label all wires prior to disconnection when servicing controls. Wiring errors can cause improper and dangerous operation. Verify proper operation after servicing.

Electrical Connections (Figure 9) continued-

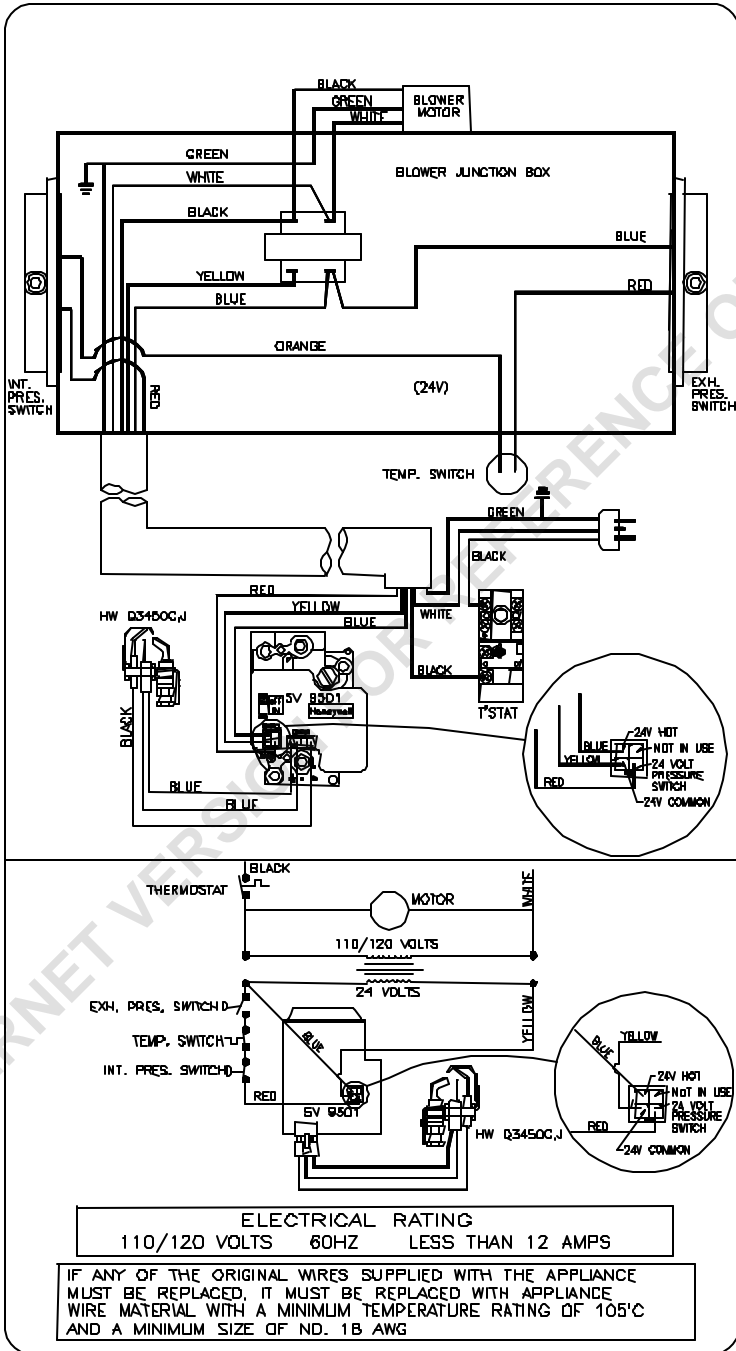

Figure 9

GENERAL OPERATION

WARNING

Water heaters are heat-producing appliances. To avoid damage or injury there must be no materials stored against the water heater or vent-air intake system, and proper care must be taken to avoid unnecessary contact (especially by children) with the water heater and vent-air intake system.

UNDER NO CIRCUMSTANCES MUST FLAMMABLE MATERIALS, SUCH AS GASOLINE OR PAINT THINNER BE USED OR STORED IN THE VICINITY OF THIS WATER HEATER, VENT-AIR INTAKE SYSTEM OR IN ANY LOCATION FROM WHICH FUMES COULD REACH THE WATER HEATER OR VENT-AIR INTAKE SYSTEM.

TO FILL THE WATER HEATER

1. Close the water heater drain valve using a standard screwdriver.
2. Open the cold water supply shut-off valve.
3. Open several hot water faucets to allow air to escape from the system.
4. When a steady stream of water flows from the faucets, the water heater is filled. Close the faucets and check for water leaks at the water heater drain valve, combination temperature and pressure relief valve and the hot and cold-water connections.

TO DRAIN THE WATER HEATER

Should it become necessary to completely drain the water heater, make sure you follow the steps below:

1. Shut off the gas supply to the water heater.
2. Turn off/disconnect all electric power to the water heater.
3. Close the cold water supply shut-off valve.
4. Open the drain valve on the water heater using a standard screwdriver. The drain valve has threads on the end that will allow the connection of a standard hose coupling.
5. Open a hot water faucet to allow air to enter the system.

To refill the water heater, refer to "To Fill the Water Heater."

Lighting and Shutdown Instructions

FOR YOUR SAFETY READ BEFORE LIGHTING

WARNING: If you do not follow these instructions exactly, a fire or explosion may result causing property damage, personal injury or loss of life.

- A. This appliance is equipped with an ignition device which automatically lights the pilot. Do not try to light the pilot by hand.
- B. BEFORE OPERATING smell all around the appliance area for gas. Be sure to smell next to the floor because some gas is heavier than air and will settle to the floor.
- WHAT TO DO IF YOU SMELL GAS**
- Do not try to light any appliance.
 - Do not touch any electrical switch, do not use any phone in your building.
 - Immediately call your gas supplier from a neighbor's phone. Follow the gas supplier's instructions.
 - If you cannot reach your gas supplier, call the fire department.
- C. Use only your hand to slide the gas control switch. Never use tools. If the switch cannot be moved by hand, do not try to repair it, call a service technician. Force or attempted repair may result in a fire or explosion.
- D. Do not use this appliance if any part has been under water. Immediately call a qualified service technician to inspect the appliance and to replace any part of the control system and any gas control which has been under water.

OPERATING INSTRUCTIONS

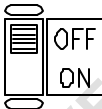
1. STOP! Read the safety information above on this label.
 2. Turn off all electric power to the appliance.
 3. Set the thermostat to lowest setting.
 4. This appliance is equipped with an ignition device which automatically lights the pilot. Do not try to light the pilot by hand.
 5. Slide the switch on the left side of the gas valve to the "OFF" position.
- GAS VALVE CONTROL SHOWN IN "OFF" POSITION**
- 
6. Wait five (5) minutes to clear out any gas. Then smell for gas, including near the floor. If you then smell gas, STOP! Follow "B" in the safety information above on this label. If you do not smell gas, go to next step.
 7. Slide the switch on the left side of the gas valve to the "ON" position.
 8. Set thermostat to desired setting.
 9. Turn on all electric power to the appliance.
 10. If the appliance will not operate, follow the instructions "To Turn Off Gas To Appliance" and call your service technician or gas supplier.

TO TURN OFF GAS TO APPLIANCE

1. Turn off all electric power to the appliance.
2. Set the thermostat to lowest setting.
3. Slide the switch on the left side of the gas valve to the "OFF" position.

Thermostat Adjustment

▲ CAUTION

Before adjusting thermostat(s), turn off power supply to the water heater.

The thermostat dial is adjusted to approximately 120°F when shipped from the factory. When adjusting the thermostat, it should be remembered that lower temperature settings are more energy efficient. The thermostat cover, to the right of the gas valve, must be removed when the thermostat is adjusted. To adjust the thermostat turn the dial clockwise with a screwdriver until the minimum acceptable temperature is set. It is suggested that the starting point setting not exceed the 120°F (49°C) or "HOT" setting on the thermostat.

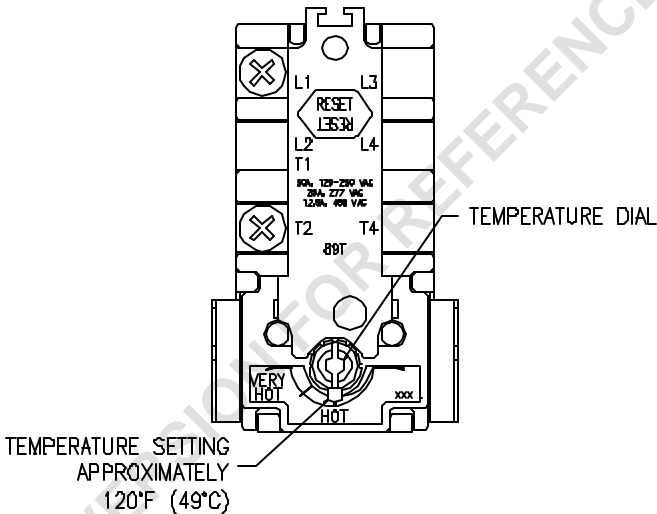

Figure 10

▲ DANGER

Hotter water increases the risk of scald injury. Scalding may occur within five (5) seconds at a temperature setting of 135°F (57.3°C). To protect against hot water injury, install an ASSE approved mixing valve in the water system. This valve will reduce point of discharge water temperatures by mixing cold and hot water in branch water lines. A licensed plumbing professional or local plumbing authority should be consulted.

Note: This water heater is equipped with an energy cut out device to prevent overheating. Should overheating occur, turn off the electrical supply to the water heater and contact a qualified service technician.

Burner Flame Check

Cast Iron Burner: At the time of installation and at periodic intervals (not more than 6 months), a visual check of the main burner and pilot flames should be made to determine if they are burning properly. For ideal operation, the gas and air must be properly proportioned. The proper air-gas mixture is obtained by adjusting the air shutter on the mixer face of the main burner (See Figure 11). To adjust for proper burning, loosen the air shutter nut (if provided), rotate shutter to close the opening in the burner then slowly rotate the shutter until the yellow tips disappear and the flame becomes blue. On 75-gallon models fired on LPG or propane, adjust the air shutter as described above until the yellow flame is minimized (note-the burner flame may contain a mixture of yellow and blue). Tighten the air shutter nut (if provided). Too much air will cause the flame to lift off the burner ports and create noisy operation. Too little air will result in soot formation. The main burner flame should light smoothly from the pilot.

Steel Burner: These models are equipped with self adjusting air mixture and do not have an adjustable air shutter (See Figure 11). At periodic intervals a visual check of the main burner and pilot flames should be made to determine if they are burning properly. The main burner flame should light smoothly from the pilot.

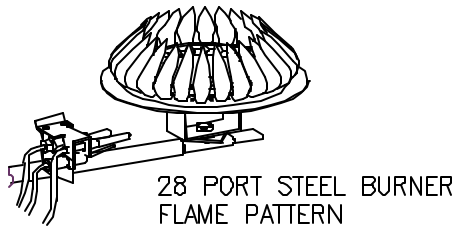
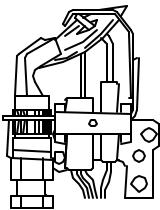
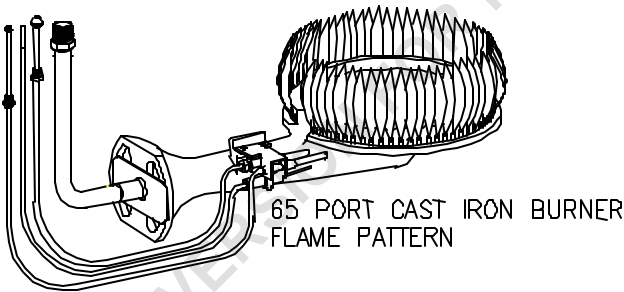

Figure 11

MAINTENANCE

WARNING

Water heaters are heat-producing appliances. To avoid damage or injury there must be no materials stored against the water heater or vent-air intake system, and proper care must be taken to avoid unnecessary contact (especially by children) with the water heater and vent-air intake system.

UNDER NO CIRCUMSTANCES MUST FLAMMABLE MATERIALS, SUCH AS GASOLINE OR PAINT THINNER BE USED OR STORED IN THE VICINITY OF THIS WATER HEATER, VENT-AIR INTAKE SYSTEM OR IN ANY LOCATION FROM WHICH FUMES COULD REACH THE WATER HEATER OR VENT-AIR INTAKE SYSTEM.

IMPORTANT

The water heater should be inspected at a minimum annually by a qualified service technician for damaged components and/or joints not sealed. DO NOT operate this water heater if any part is found damaged or if any joint is found not sealed.

A qualified service technician should perform the following maintenance at the minimum periodic intervals suggested below. In some installations, the maintenance interval may be more frequent depending on the amount of use and the operating conditions of the water heater. Regular inspection and maintenance of the water heater and vent-air intake system will help to insure safe and reliable operation.

1. Annually check the operation of the thermostat.
2. The flow of combustion and ventilation air **MUST NOT** be restricted. Clear the combustion air openings of any dirt, dust, or other restrictions.
WARNING! The ventilation air system may be **HOT**.
3. At all times keep the water heater area clear and free from combustible materials, gasoline and other flammable vapors and liquids.
4. Bi-annually conduct a visual check of the main and pilot burner flames to determine that they are burning properly. See Burner Flame Check section on page 31. If sooting or other burner anomalies are evident, shut down the water heater by turning off the gas per the instructions listed in this manual or as listed on the water heater.

Maintenance continued-

5. Annually remove the inner door and main burner assembly to clean orifices and related parts of any dirt or other foreign material. Inspect the burner ports for obstructions or debris and clean with a wire brush as needed. Wire brush and/or vacuum clean the combustion chamber as needed to remove scale deposits and debris. **NOTE: It is imperative for proper operation of the water heater that the inner door be replaced in the original location.**

▲WARNING

When lifting lever of the combination temperature and pressure relief valve, hot water will be released under pressure. Be careful that any released water does not result in bodily injury or property damage.

6. At least once a year, check the combination temperature and pressure relief valve to insure that the valve has not become encrusted with lime. Lift the lever at the top of the valve several times until the valve seats properly without leaking and operates freely.
7. Monthly drain off a gallon of water to remove silt and sediment.

▲WARNING! THIS WATER MAY BE HOT.

8. If the combination temperature and pressure relief valve on the appliance discharges periodically, this may be due to thermal expansion in a closed water supply system. Contact the water supplier or local plumbing inspector on how to correct this situation. **Do not plug the combination temperature and pressure relief valve outlet.**
9. A combination sacrificial anode rod/hot water outlet nipple has been installed to extend tank life. The anode rod should be inspected periodically (every 2 years) and replaced when necessary to prolong tank life. Water conditions in your area will influence the time interval for inspection and replacement of the anode rod. Contact the plumbing professional who installed the water heater or the manufacturer listed on the rating plate for anode replacement information. The use of a water softener may increase the speed of anode consumption. More frequent inspection of the anode is needed when using softened (or phosphate treated) water.
10. The induced draft blower has sealed motor bearings and does not require adding oil.

Maintenance (continued)-

▲CAUTION

FOR YOUR SAFETY. **DO NOT** ATTEMPT REPAIR OF COMBINATION GAS CONTROL, BURNERS OR GAS PIPING. REFER REPAIRS TO A QUALIFIED SERVICE TECHNICIAN.

Contact your supplier or plumbing professional for replacement parts or contact the company at the address given on the rating plate of the water heater.

Provide the part name, model and serial numbers of the water heater when ordering parts.

READ THE WARRANTY FOR A FULL EXPLANATION OF THE LENGTH OF TIME THAT PARTS AND THE WATER HEATER ARE WARRANTED.

Manufactured under one or more of the following U.S. Patents:
RE. 34,5434 B1 5,341,770; 4,416,222; 4,628,184; 4,669,448; 4,672,919;
4,808,356; 4,829,983; 4,861,968; 4,904,428; 5,000,893; 5,023,031;
5,052,346; 5,081,696; 5,092,519; 5,115,767; 5,199,385; 5,277,171;
5,372,185; 5,485,879; 5,574,822; 5,596,952; 5,660,165; 5,682,666;
5,761,379; 5,943,984; 5,954,492; 5,761,379; 5,988,117; 6,142,216. Other
U.S. and Foreign patents applications pending.
Current Canadian Patents: 1,272,914; 1,280,043; 1,289,832; 2,107,012;
2,112,515; 2,045,862; 2,108,186.

Complete the following information and retain for future reference:

Model No: _____

Serial No: _____

Service Phone

Days: _____ Nights: _____

Address: _____

Supplier: _____

Supplier Phone No: _____

PARTS LIST DRAWING

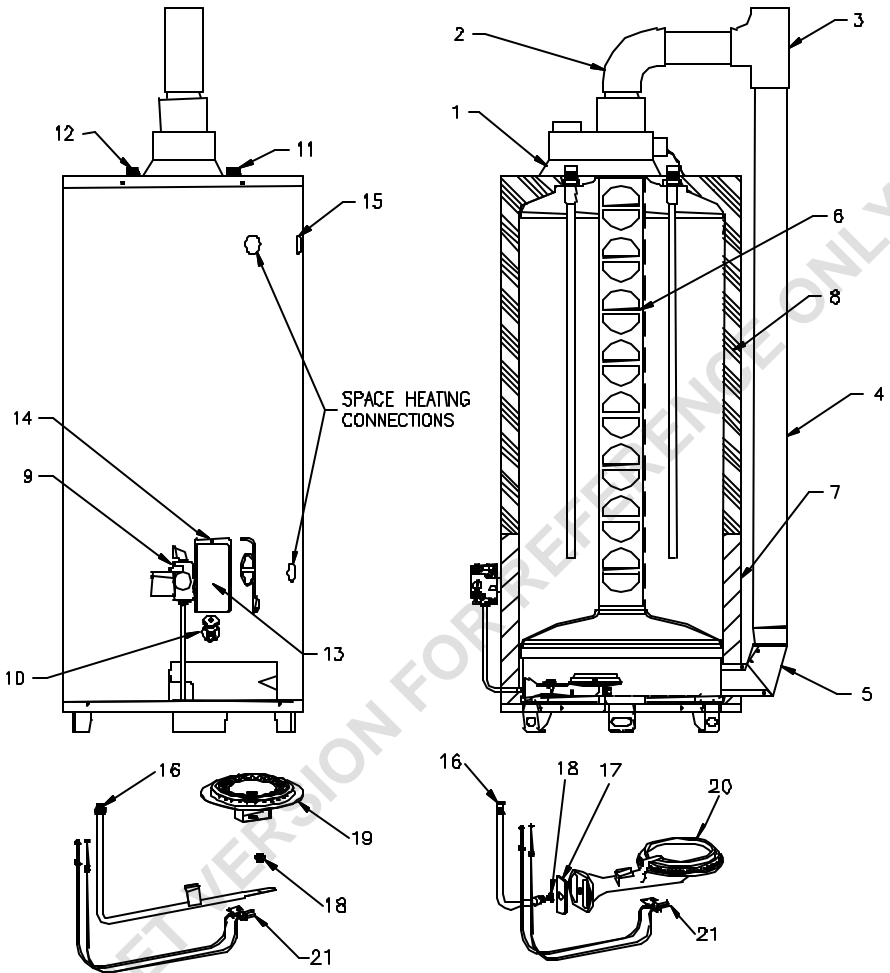

PART NAME AND DESCRIPTION	
1. Blower Assembly	12. Anode – Nipple
2. Rubber Intake Elbow	13. Thermostat (Behind Cover)
3. Intake Tee (Supplied)	14. Thermostat Cover
4. Vertical Pipe (Supplied)	15. T & P Relief Valve Opening
5. Metal Intake Boot	16. Gas Feedline
6. Flue Baffle	17. Air Shutter (Cast Iron Only)
7. Fiberglass Insulation	18. Main Burner Orifice
8. Foam Insulation	19. Steel Burner
9. Honeywell Smartvalve	20. Cast Iron Burner
10. Drain Valve	21. Pilot Assembly

INTERNET VERSION FOR REFERENCE ONLY

BLOWER PARTS DRAWING

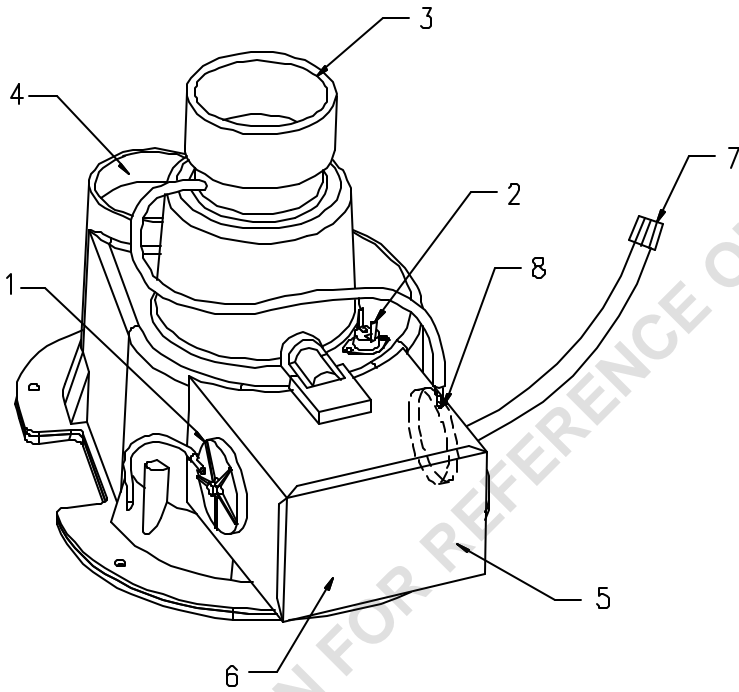

PART NAME AND DESCRIPTION	
1.	Exhaust Pressure Switch
2.	ECO Switch
3.	Intake Collar
4.	Exhaust Connection
5.	Junction Box
6.	Transformer (Behind Junction Box Cover)
7.	Six Pin Blower Connector
8.	Intake Pressure Switch (Not Shown)

THE FOLLOWING INSTRUCTIONS ARE FOR INSTALLATION OF: GAS WATER HEATERS SUITABLE FOR WATER (POTABLE) HEATING AND SPACE HEATING

1. All piping components connected to this water heater for space-heating applications must be suitable for use with potable water. In Massachusetts, space heating piping length **must not** exceed 50 feet.
2. Toxic chemicals, such as those used for boiler treatment, **must not** be introduced into potable water used for space heating.
3. This water heater **must not** be connected to an existing heating system or component(s) previously used with a non-potable water heating appliance.
4. When the system requires water for space heating at temperatures higher than required for other means, such as an ASSE approved mixing valve must be installed to temper the water for those uses in order to reduce the scald hazard potential.

Please refer to the illustration below for the suggested piping arrangement.

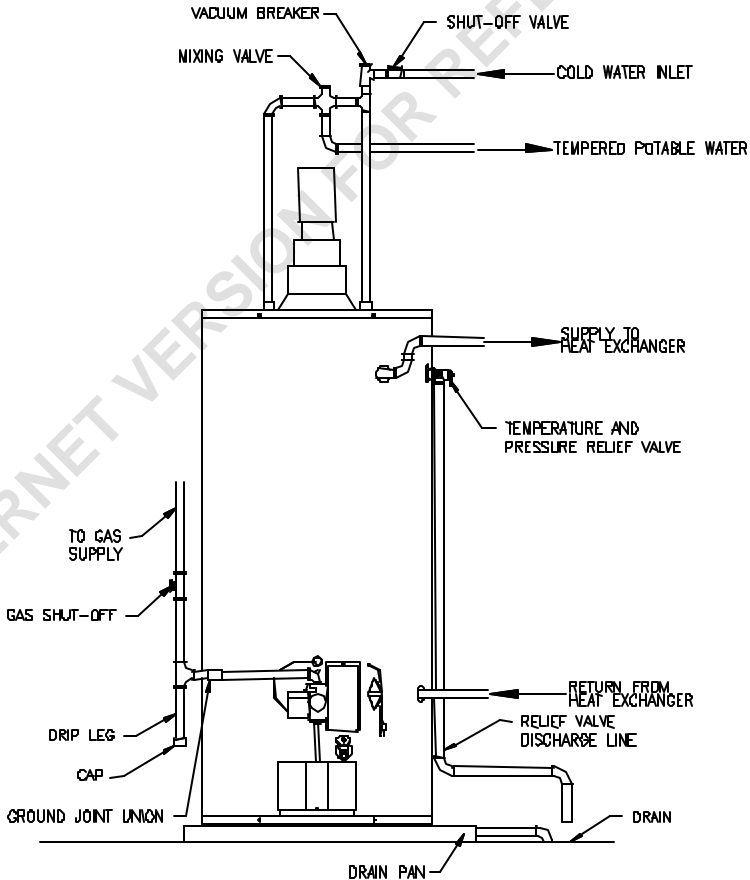

VENT PIPE PREPARATION AND JOINING

Most failures in PVC, CPVC or ABS systems result from improper preparation and joining of pipe and fittings. The guidelines below must be followed when installing the venting system. If you have any question about the application or installation of the PVC, CPVC or ABS venting system, contact the manufacturer, supplier, or your plumbing professional.

- 1) Specific cleaners, solvents, primers and cements are available for PVC, CPVC and ABS pipe. Be sure these materials match the type of pipe to be installed. Never use all-purpose cements, commercial glues and adhesives or ABS cement to join PVC or CPVC pipe and fittings.
 - a) **CLEANERS, SOLVENTS, PRIMERS AND CEMENTS ARE FLAMMABLE. Do not store or use these materials near heat or open flame, or in the vicinity of other appliances.**
- 2) Use proper cutting, deburring and applicator tools to ensure proper preparation and joining of pipe and fittings.
 - a) Cutting Tools
 - i) A square cut must be achieved with a miter box saw or pipe cutter to ensure a proper mating with the female. If a pipe cutter is used, the burr created at the outer edge of the pipe must be removed.
 - b) Deburring Tools
 - i) A file, knife or plastic deburring tool can be used to remove burrs. Burrs must be removed from the inside and outside edges of the pipe to ensure a proper seal.
 - c) Applicator Tools
 - i) A pure bristle paintbrush or roller may be used to apply cement. Prompt application of the cement is important due to its fast drying properties.
- 3) Inspection, Cleaning, Priming and Cementing
 - a) Inspect the pipe inside and out for dirt, dust, moisture or grease etc. Check pipe and fittings for splits or cracks and replace if necessary.
 - b) Clean pipe and fittings are imperative for proper joining. Following cutting and deburring, wipe away any foreign material with a clean dry rag. If wiping fails to thoroughly clean surfaces, chemical cleaning is necessary.
 - c) Primer must be applied to the pipe surface and fitting socket with a natural bristle brush. This serves to soften and prepare the PVC or CPVC for cementing.

Vent Pipe Preparation and joining (continued)-

- d) Cementing must be done quickly to avoid over-drying before joining.
 - i) Apply one coat to the outside end of the pipe at a width slightly greater than the depth of the socket.
 - ii) Apply a coat around the inside of the fitting socket.
 - iii) Apply a second coat around the end of the pipe.
- 4) Joining
 - a) Joints should be made immediately after cement is applied.
 - b) After fully inserting pipe into fitting socket, give pipe about $\frac{1}{4}$ turn to help spread cement evenly. Hold joint together for about 15 to 20 seconds.
 - c) Remove excess cement from around pipe and fitting with a clean rag.
 - d) Cement drying times may vary. Be sure to allow for the recommended drying time before disturbing joints.

For more specific and detailed information about the above, contact the manufacturer, supplier, or competent professional.

INTERNET VERSION FOR REFERENCE ONLY