



On3 H3 Series

User Manual
Version 1.00

Copyright © 2013 0n3 S.r.l. – Rome, Italy

Subject to change without notice

The information contained in this document is provided for informational purposes only. While efforts were made to verify the accuracy of the information contained in this documentation, it is provided “as is” without warranty of any kind.

Third-party brands and names are the property of their respective owners.

www.0n3.eu

Acronyms	5
General Information	6
1.1 Manual organization	6
1.2 Organization of safety notices	6
1.3 Safety guidelines	6
1.3.1 Responsibilities	6
1.3.2 Intended use	8
1.3.3 Protection against electrostatic discharges	8
1.3.4 Transport and storage	8
1.3.5 Installation	8
1.3.6 Operation main facts	9
1.3.7 Supply voltage	9
1.3.8 Emergency Stop push-button	9
1.3.9 Enabling Device	10
1.3.10 State Selector	11
1.3.11 Environmentally-friendly disposal	12
1.3.11.1 Disposal	12
Technical data	13
2.1 Introduction	15
2.2 Selection guide	16
2.3 Product coding	17
2.4 System overview	17
2.4.1 H3 terminal overview	17
2.4.1.1 Ergonomics	18
2.4.1.2 Housing	18
2.4.1.3 Operating and display field	18
2.4.1.4 Electronics	18
2.4.1.5 Input devices	19
2.4.1.5.1 Override potentiometers	19
2.4.1.5.2 Handwheel (optional)	19
2.4.1.5.3 Rubber keypad	19
2.4.1.6 Interfaces to NC/PLC	20
2.4.1.7 USB interface	20
2.4.1.8 Touch screen pen	21
2.4.1.9 Safety related devices	21
2.4.2 Connection box overview	22
2.4.3 Dimensions	23
2.4.3.1 Terminal	23
2.4.3.2 Connection Box	24

2.5	Technical data details	25
2.5.1	Handheld terminal specifications	25
2.5.1.1	Handheld terminal chemical resistance	27
2.5.1.1.1	Test results	28
2.5.2	Cable connections	29
2.5.3	Cable connector specifications and pin-out	30
2.5.3.1	DB25 connector pin-out	30
2.5.4	Safety-related devices	31
2.5.4.1	Emergency Stop button	31
2.5.4.2	Enabling device	31
2.5.4.3	State Selector	31
2.6	Connection box cabling scheme	32
2.6.1	Cabling: H3 to Connection Box	33
2.6.2	Cabling: Connection Box to CN/PLC	35
2.7	Standards	36
2.7.1	EC Directives	36
2.7.2	International Safety Standards	36

Acronyms

CNC: Computer Numerical Control
DC: Diagnostic Coverage
DLL: Dynamic-Link Library
ESD: Electrostatic Discharge
HMI: Human-Machine Interface
ISO: International Organization for Standardization
TFT: Thin Film Transistor
LCD: Liquid Crystal Display
MDI: Manual Data Input
MTTF_d: Mean Time To dangerous Failure
OS: Operative System
PCB: Printed Circuit Board
PLC: Programmable Logic Controller
PUR: Polyurethane
RGB: Red Green Blue
R/W: Read/Write
USB: Universal Serial Bus
VDC: Volts of Direct Current
XML: eXtensible Markup Language
PN: Part Number
SN: Serial Number

chapter 1

General Information

1.1 Manual organization

This user manual is intended to give all kind of information regarding H3 handheld terminal. Chapter 1 is dedicated to general information, operation and safety main notices and an high level explanation of the device. Chapter 2 at first gives an overview to each component and then gives the detailed technical data.

1.2 Organization of safety notices

All safety notices in this manual are specified as follows:

Safety notice	Description
Danger!	Respecting guidelines and regulations avoids life-risks
Caution!	Respecting guidelines and regulations avoids severe injuries or damage to material
Warning!	Respecting guidelines and regulations avoids injuries or damage to material
Information:	Respecting guidelines and regulations avoids errors

1.3 Safety guidelines

1.3.1 Responsibilities

H3 handheld terminal is a small, light and comfortable remote system controller which, appositely configured and connected to a machine control logic and safety, guarantees machine control and configuration and the implementation of safety related functions.

All configuration and control commands selected through the keyboard or the touch screen display, the optional handwheel and the potentiometers status are sent to the machine control logic through a serial or ethernet communication channel. H3 is available in two versions, depending on the desired communication interface: ETHERNET or RS-422.

The safety related devices available on the H3 handheld terminal are: Emergency Stop push-button, Enabling Device and State Selector.

All handheld terminal outputs: ETHERNET/RS-422 signals and the safety related devices outputs, are cable connected to the machine control logic.

Danger!

- User is responsible for the correct device installation and interfacing to the machine control logic.
- User is responsible for implementing the machine safety related functions. H3 handheld terminal provides the best state of the art technology safety devices.
- User should implement the safety related functions according to the application safety level determined in a previous risk analysis.
- User, during machine control logic implementation, is responsible for considering all conditions related to the machine operations:
 - a) checking the Emergency Stop push-button, Enabling Device and State Selector status;
 - b) checking all possible further safety devices available on board of the machine: safety fences, optical barriers and so on.
- User is responsible for considering all further safety and accident prevention guidelines related to the particular working environment in addition and independently from this document.
- User is responsible for observing all safety precautions applying to industrial control systems in accordance with national and international regulations.
- User is responsible for observing that all installation, commissioning and maintenance tasks must be carried out only by qualified personnel, so by persons who are familiar with transport, mounting, installation, commissioning and operation of the product and who have the appropriate qualifications. Furthermore it is suggested to follow all national accident prevention guidelines.
- All safety guidelines, cabling schemes, mechanical and electrical limit values listed in the technical data must be read before installation and commissioning and strictly respected.
- User is not allowed to take care of the maintenance and repair of the safety devices on board of ON3 H3 terminal. Each maintenance and repair operation must be remanded to ON3 srl.

Information:

- All instructions contained in this manual ensuring user safety must be taken in consideration. Each non-conformity could cause the safety functions integrated in the handheld terminal not to work properly.

1.3.2 Intended use

H3 handheld terminal has been designed, developed, and manufactured for conventional use in industry. It was not designed, developed, and manufactured for any use involving serious risks or hazards that could lead to death, injury, serious physical damage, or loss of any kind without the implementation of exceptionally stringent safety precautions. Such risks and hazards include the use of H3 handheld terminal in the following applications:

- nuclear reactions monitoring in nuclear power plants;
- flight control systems;
- flight safety;
- mass transit control systems;
- medical life support systems;
- control of weapons systems.

1.3.3 Protection against electrostatic discharges

Electrical components that are vulnerable to electrostatic discharge (ESD) must be handled accordingly.

Danger!

- Do not touch the connector contacts;
- Do not touch the contact tips when removing the protection covers.

1.3.4 Transport and storage

All kind of environmental (temperature, aggressive atmospheres, humidity) and mechanical stresses over the accepted limits explained in 2.5 must be avoided during transport and storage of the devices. Two main considerations must be done in order to prevent damages during transport:

Warning!

- always use the original packaging;
- always keep the right environmental conditions as explained in the technical data.

1.3.5 Installation

Installation must take place according to the documentation and using suitable equipment and tools.

Warning!

- All devices must be installed by qualified personnel and without voltage supplied
- All national regulations about accident prevention must be taken into account
- Electrical installation must follow the fundamental guidelines (line cross section, protective ground connection, the electrical limits explained in the technical data etc.)

1.3.6 Operation main facts

Warning!

- Take care not to squeeze and thus damage the cable with any object.
- Make sure that nobody can fall over the cable to avoid that the device falls to ground.
- Do not lay the cable over sharp edges to avoid damaging the cable sheath.
- Always operate the touch screen with the proper touch-pen. Never use sharp objects that could damage the touch screen.

1.3.7 Supply voltage

Caution!

- The supply circuit must be protected using a 0.25A slow-blow fuse.

1.3.8 Emergency Stop push-button

The Emergency Stop push-button provides two redundant switching N.C. (Normally Closed) contacts. User should directly connect the Emergency Stop push-button outputs to the machine cabinet and monitoring devices. For further information about the handheld terminal cable pin-out please refer to paragraph 2.5.2.

For the related safety function once it is interfaced with the machine control logic (please refer to paragraph 2.5.4.1).

Warning!

- User is responsible for interfacing the Emergency Stop push-button to the machine control logic and implementing the Emergency Stop function according to the safety level determined in a previous risk analysis.
- User is responsible for interfacing the Emergency Stop push-button to the machine control logic implementing the Emergency stop function in category 0 or category 1.
- In case of drop or other possible damages of the device, the stop function operation must always be checked by the operator.
- Releasing the Emergency Stop push-button must never cause an uncontrolled restart. User is responsible for implementing this controls on the machine control logic.
- The Emergency Stop push-button on the handheld terminal is not a substitute for the Emergency Stop push-button located on the machine.
- For further and more detailed information about the Emergency Stop push-button, as the electrical and mechanical life, please refer to paragraph 2.4.1.9 and 2.5.4.1.

1.3.9 Enabling Device

The Enabling Device is a three positions enable switch providing two redundant switching N.O. (Normally Open) contacts.

User should directly connect the Enabling Device outputs to the machine cabinet and monitoring devices. For further information about the handheld terminal cable pin-out please refer to paragraph 2.5.2.

Two positions, “Null” and “Panic”, represent off condition while only the “Enable” position allows activation.

For the related safety function once it is interfaced with the machine control logic (please refer to paragraph 2.5.4.2).

Warning!

- User is responsible for interfacing the Enabling Device to the machine control logic and implementing the enabling function according to the safety level determined in a previous risk analysis.
- The enable switch fulfils its protective function only if the operator can recognize the danger in time.
- In case of dangerous states the logic controller must provide that, additionally to the enable switch, another conscious start command should be required to allow activation.
- The only person permitted in the dangerous area is the person activating the enable switch.
- For further and more detailed information about the enable switch, as the electrical and mechanical life, please refer to paragraph 2.4.1.9 and 2.5.4.2.

Functionality

The Enabling Device can have three different positions:

Switch position	Function	Enable switch	Switching contact
1	Zero position	Not pressed	Off (opened)
2	Enable	Pressed	On (engaged)
3	Panic	Pushed all the way in	Off (opened)

The positions null and panic must be cabled and controlled by the machine logic in order to guarantee a stop category 0 or 1.

Zero position

When not pressed the Enabling Device returns to the zero position

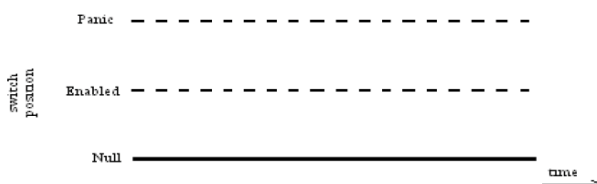

Figure 1: Zero position

Enable position

When pressed the Enabling Device goes into the enabling position. This condition is often associated to machine movement activation. When released it goes back to the null position.

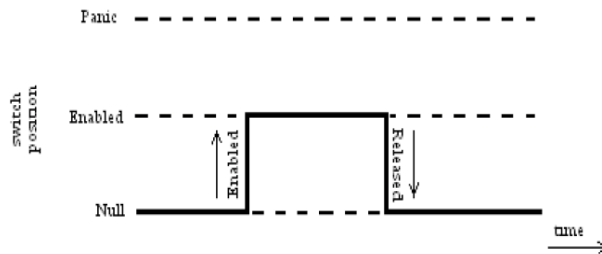

Figure 2: Enable position

Panic position

When the Enabling Device is pushed all the way in it goes to the panic position which corresponds to the same contact condition as the zero state.

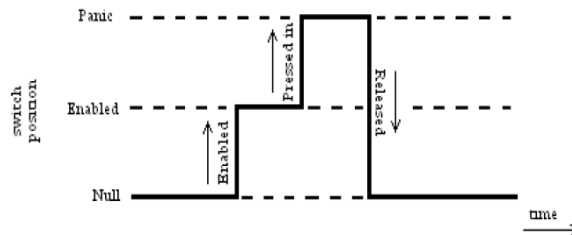

Figure 3: Panic position

If the switch is pushed all the way in and then released it goes directly to the null state skipping the enable position.

1.3.10 State Selector

The State Selector is a 16 states BCD coded rotary switch with four non-redundant outputs and a common contact.

User should directly connect the State selector outputs and common contact to the machine cabinet and monitoring devices. For further information about the handheld terminal cable pin-out please refer to paragraph 2.5.2.

For the related safety function once it is interfaced with the machine control logic (please refer to paragraph 2.5.4.3).

Warning!

- User is responsible for interfacing the State selector to the machine control logic and implementing the state selecting function according to the safety level determined in a previous risk analysis.
- The State Selector function should be only related to the selection of the various working modes available on the machine by the logic controller.
- For further and more detailed information about the State Selector, as the electrical life, please refer to paragraph 2.4.1.9 and 2.5.4.3.

1.3.11 Environmentally-friendly disposal

All components related to H3 handheld terminal are designed to respect the environment and reduce as much as possible its impact on pollution.

1.3.11.1 Disposal

It is important to specify how to dismiss the different components of H3 terminal in order to have an environmentally-friendly recycling process.

Component	Disposal
Cable Electronic boards	Electronic recycling
Paper packaging	Paper recycling
Plastic packaging	Plastic recycling

Chapter 2

Technical data

2.1 Introduction

H3 handheld terminal is a small, light and robust mobile panel featuring a powerful processor widely used in industrial products, a high reliability solid state disc and a RAM memory bigger and faster than H2, a comfortable 5" TFT LCD color touch display and a USB 2.0 port. The processor runs Windows CE 6.0 operating system. Customer has complete freedom of operation on the OS and can build his own application, use third party software or run the available application from ON3. Emergency Stop push-button, Enabling Device and State Selector are available on board. All configuration and control commands selected through the keyboard or the touch screen display, the optional Handwheel and the potentiometers status are sent to the machine control logic through an ETHERNET or RS-422 serial communication channel. The data signals (RS-422 /ETHERNET), the Emergency Stop push-button, Enabling Device and State Selector outputs are cable connected to the machine control logic.



Figure 4: H3 handheld terminal

A Connection Box complete the system. The Connection Box is useful for a comfortable connection to the machine cabinet. For further info please refer to 2.6. All of the components related to the H3 handheld terminal and the interface to the machine control logic are hereunder schematically presented:

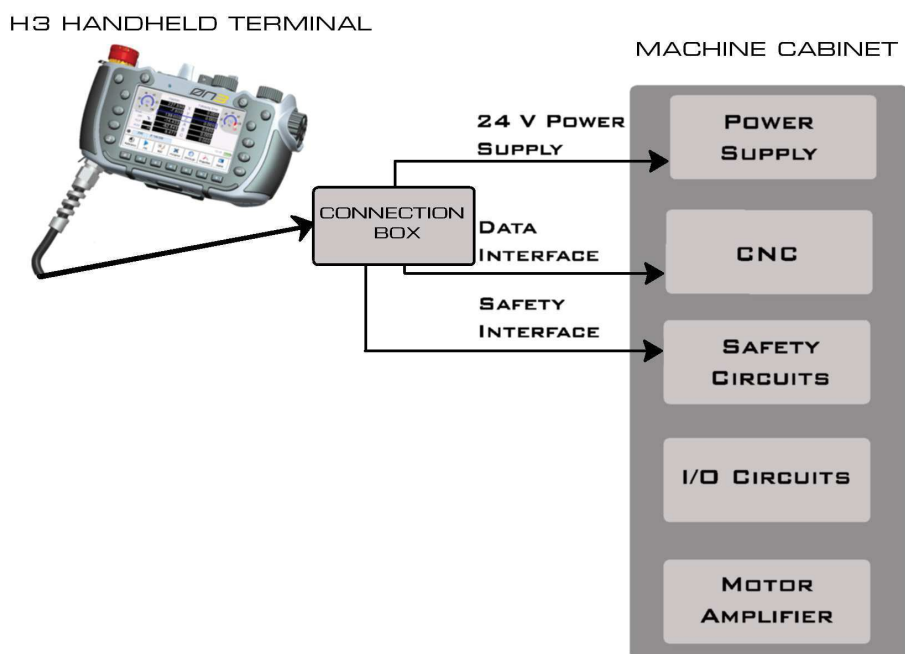

Figure 5: H3 system overview

2.2 Selection guide











H3 HANDHELD TERMINAL SELECTION GUIDE							H A N D W H E E L	H A N D H E L D
								
RS-422		ETHERNET		RS-422		ETHERNET		INTERFACE
BLACK CABLE 10m or 20m		BLUE CABLE (CAT5 E) 5m, 10m or 20m		BLACK CABLE 10m or 20m		BLUE CABLE (CAT5 E) 5m, 10m or 20m		CABLE TYPE
DB-25	FREE WIRES	FREE WIRES	FREE WIRES	DB-25	FREE WIRES	FREE WIRES	FREE WIRES	CONNECTION TYPE
								
H3 ACCESSORIES								A C C E S S O R I E S
						CONNECTION BOX		

Figure 6: H3 handheld terminal selection guide

2.3 Product coding

Product coding scheme as below. For ordering please contact your sales representative.

Fixed fields	+ E P 3				
Product&family	H 3	H=HMI 3=H3	C=Control 4=H4	S=Safety	
Version	R S	R=Wired S= serial (wired)	S=Wireless E=Ethernet (wired)	B=Bluetooth (wireless)	W=WIFI (Wireless)
OS	C	C=Windows CE	L=Linux		
Cable length	1	1=5 mt	2=10 mt	3=15 mt	4=20 mt
Optionals	R 0	R=RFID S=Splitter	C=Camera B=stand by station	E=Hearphones 2=4 GB SD card	H=Handwheel 3=8 GB SD card
Custom fields	0 0	e.g. specific configurations			
Cable termination	1	1=Free termination	2=Circular connector	3=DB 25 connector	0=Not applicable

Figure 7: Product coding scheme

2.4 System overview

2.4.1 H3 terminal overview

H3 handheld terminal is hereunder in detail presented:

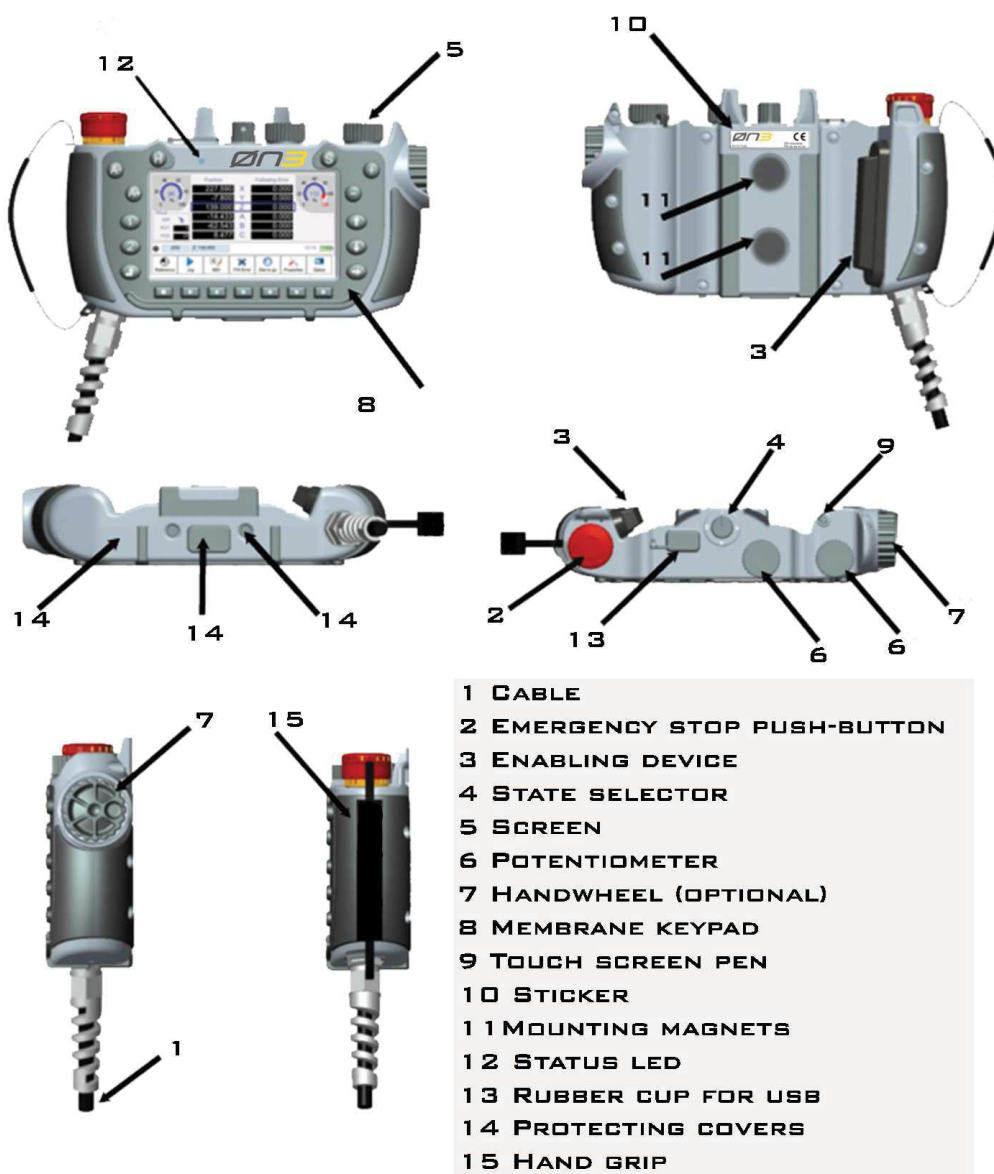

Figure 8: H3 handheld terminal overview

2.4.1.1 Ergonomics

- Functional hand grip, user configurable;
- Comfortable and safe access to safety related devices;
- Comfortable and secure handling using rubber membrane keyboard and covering surface;
- Comfortable handling, also using gloves, thanks to well-designed command key spacing;
- Clear display, user configurable brightness.

2.4.1.2 Housing

- Vibration and shock resistant.
- Non-flammable material housing (fulfills UL 94-HB), impact-resistant, water-resistant IP 64, cleaning agents (alcohol and fabric conditioner), oils, cutting oils (drilling oils), fat and lubricants resistant.
- Extremely robust housing.

2.4.1.3 Operating and display field

- Rubber covered keys with mechanical pressure point.
- 2 LED's:
 - RED color: indicates hardware failures;
 - GREEN color: may be fixed or blinking and is controlled by OS;
- Touch screen TFT LCD Display.

2.4.1.4 Electronics

- CPU
 - 600MHz ARM Cortex-A8 core;
 - 16kB instruction Cache;
 - 256kB L2 Cache;
 - Embedded Graphic engine;
 - Flash Memory: 128MB Flash NOR Solid State Disc (SSD);
 - RAM Memory: 128MB DDR2 SDRAM.

2.4.1.5 Input devices

2.4.1.5.1 Override potentiometers

The two over-ride potentiometers can be used for different purposes, for instance setting the spindle speed or the machine movement speed along a certain axis.

- Resolution: 0-255 linear

2.4.1.5.2 Handwheel (optional)

The handwheel is an optional accessory. It can be used for the machine movement fine tuning in the “handwheel incremental JOG” working mode.

The handwheel counts 40 detents per each 360° turn. Clockwise turns decrement while counter-clockwise turns increment the counter.

2.4.1.5.3 Rubber keypad

The mobile panel has a rubber keypad containing 19 keys. 6 keys are command keys, useful for a direct machine control. The remaining 13 keys are function keys, useful for navigating and operating through the panels of the software application. The letter or the symbol printed on the keys reminds the function.

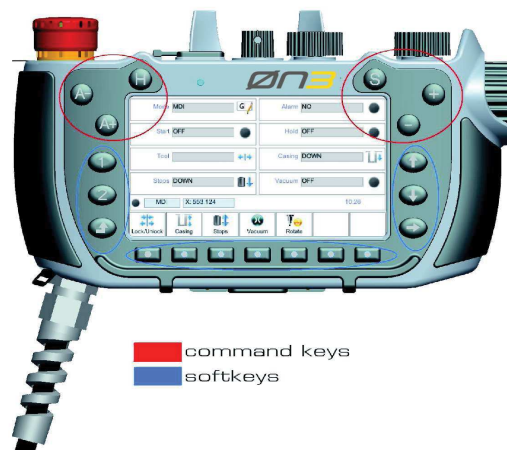





Figure 9: Keypad

Key	Function
H	Hold (Machine stop)
S	Start (Machine start)
A+	Scroll axis down
A-	Scroll axis up
+	JOG+
-	JOG-
	Next
	Level Up
	Up (Softkey)
	Down (Softkey)
1	Custom Button 1 (Softkey)
2	Custom Button 2 (Softkey)
o	Function softkey (function explained on the software application panels)

2.4.1.6 Interfaces to NC/PLC

H3 is available in two versions according to the desired communication interface:

- RS-422: Full-duplex serial interface; bitrate is user configurable.
- ETHERNET: 100 Mbps Fast Ethernet
 - fulfils standards: IEEE 802.3, IEEE 802.3u 100BASE-TX
 - supports auto cross-over (AUTO-MDI) function.

2.4.1.7 USB interface

- USB 2.0 HOST interface
- USB type-A connector
- max 500mA output current

2.4.1.8 Touch screen pen

The touch screen pen is easily accessible in the back, on the right side of the terminal.



Figure 10: Touch screen pen

2.4.1.9 Safety related devices

Hereunder is shown the detail for the safety related devices position:

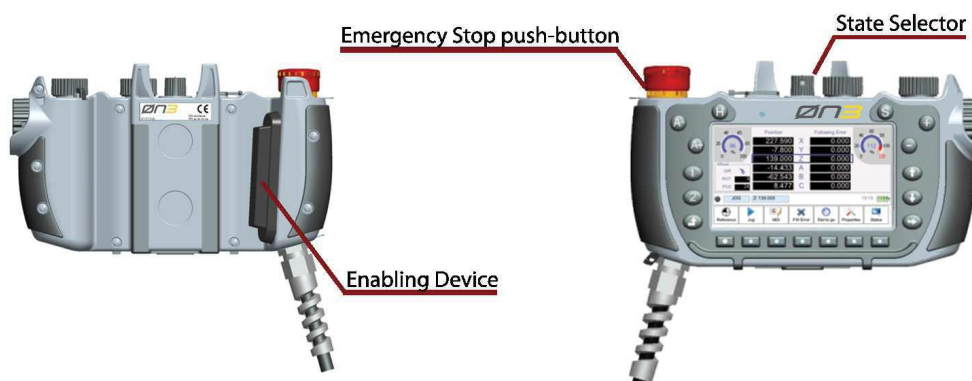

Figure 11: Safety related devices position

For all the information about the safety related devices and functions please refer to paragraphs 1.3.8, 1.3.9, 1.3.10 and 2.5.4.

2.4.2 Connection box overview

Connection Box is an easy to install DIN rail module which eases H3 installation and connection inside the machine rack.

Connection Box is a splitter which, once connected to H3 output connector or output wires, splits all signals on screw terminals or RJ45 connector (ETHERNET signals only) easing all cabling operations.



Figure 13: Connection board

2.4.3 Dimensions

2.4.3.1 Terminal

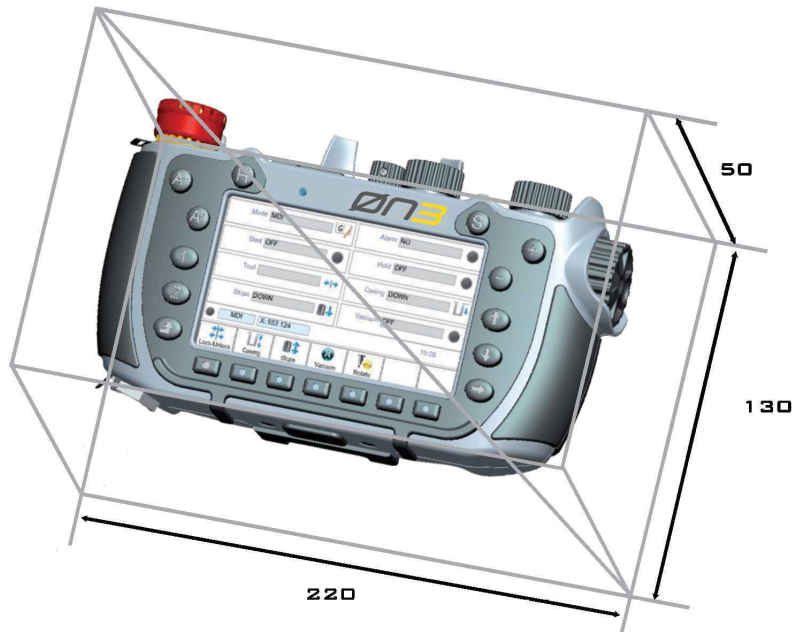

Figure 12: Terminal (dimensions in millimeters)

2.4.3.2 Connection Box

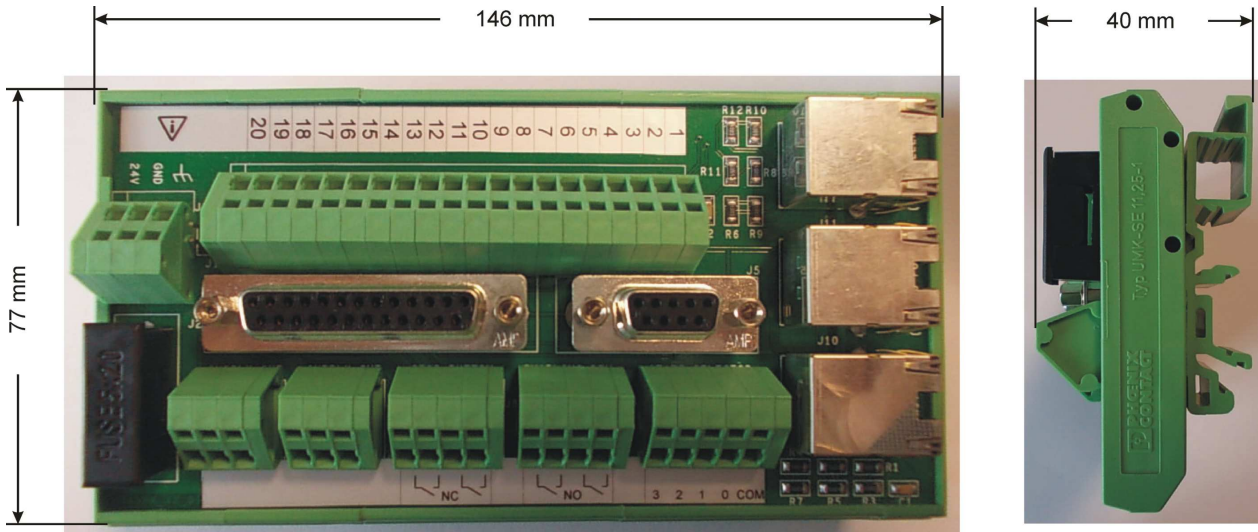

Figure 13: Connection Box dimensions

2.5 Technical data details

2.5.1 Handheld terminal specifications

FEATURES	
Operating System	Windows CE 6.0
CPU	600 MHz ARM Cortex-A8 core 16kB instruction Cache 256kB L2 Cache Embedded Graphic engine
Flash Memory	128MB Flash NOR Solid State Disc (SSD)
RAM Memory	128MB DDR2 SDRAM
RS-422 Interface (H3 RS-422 version only)	Full duplex serial communication Bitrate: user configurable Connection: 2 shielded twisted pairs
ETHERNET Interface (H3 ETHERNET version only)	10/100Mbps Fast Ethernet Fulfil standards: IEEE 802.3, IEEE 802.3u 100BASE-TX Supports auto cross-over function (AUTO-MDI) Connection: 2 shielded twisted pairs
USB interface Output current Connector	USB 2.0 HOST max 500mA USB type-A
Keyboard Command keys Softkeys	Rubber keypad 6 13
Status LED	Bicolor LED: RED/GREEN
Display Diagonal Colors Resolution Contrast ratio Viewing angle: • Horizontal • Vertical Background lighting: • Brightness • Half-brightness time Touch screen technology	TFT LCD 5" (12,7cm) 16 milions RGB 480x272 pixels 500:1 Direction Right / Direction Left = 70° Direction Up = 50° / Direction Down = 70° 300cd/m ² at least 20000 hours Resistive sensor technology

Power Supply	
Rated Voltage	24VDC \pm 25%
Max interruption of the supply	10ms
Starting current	250mA @ 24V
Power consumption	3.12W (typ) = 130mA @ 24V
Electrical insulation	No
Emergency Stop Button	2 N.C. contacts
Enabling Device	3 positions switches, 2 N.O. contacts
State Selector	16 state BCD coded
Handwheel (optional)	40 detents per turn
Override potentiometer	2 linear potentiometers
MECHANICS	
Handheld terminal color	Body structure: RAL 7035; Rubber part: RAL7016
Outer dimensions	
Length	220mm
Height	50mm
Width	130mm
Weight (without cable)	700g (H3 without handwheel) 710h (H3 with hadwheel)
ENVIRONMENT	
Temperature	
Operating temperature	+5° to +45°C
Trasport and storage tempera- ture	-20° to +70°C
Relative humidity	
Operating	Max 95%: non-condensing
Transport	Max 95%: non-condensing
Operating Altitude	Max 3000m
Protection Degree	IP64
Flame resistance	Handheld terminal housing fulfils UL 94-HB

2.5.1.1 Handheld terminal chemical resistance

Test 1 (Less strict)

The units under test (UUT) are placed in a closable plastic box (120 x 85 x 65 mm).

A ball of absorbent cotton appositely tintured with solvent will be placed above the UUT; to avoid early evaporation, a generic solid body will be put over the ball or, in a more simply way, the closable plastic box will be closed.

After a 10 minutes wait, the eventual body and the ball of absorbent cotton will be removed; the solvent that remains on the UUT will not be wiped off and the box will be closed immediately afterwards for 24 hours.

The test will be performed at environmental temperature (about 20 °C).

Test 2 (Very strict)

The units under test (UUT) are fully and thoroughly wet by solvent, then will be closed into a closable box (120 x 85 x 65 mm) for 24 h.

Approximately 5 ml solvent will be sprayed over the UUT. The box will be closed and the UUT will remain in the closed box for at least 24 hours.

The test will be performed at environmental temperature (about 20 °C).

Touchscreen test procedure

The Touchscreen is placed into a closable plastic box (120 x 85 x 65 mm) and a ball of absorbent cotton appositely tintured with solvent will be placed above it, then the box will be closed for 1 h.

The test will be performed at environmental temperature (about 20 °C).

2.5.1.1.1 Test results

Chemical Solvent	Test 1 passed	Test 2 passed	Notes
Denatured Ethyl Alcohol	Rubber (Keyboard) Handles Terminal housing Rubber cup Rubber (lateral cover)	Rubber (Keyboard) Handles Terminal housing Rubber cup Rubber (lateral cover)	
Diesel	Rubber (Keyboard) Handles Terminal housing Rubber cup Rubber (lateral cover)	Handles Terminal housing Rubber cup Rubber (lateral cover)	Test 2: Rubber (Keyboard): heavy deformation; reduced hardness
Unleaded Gasoline	Rubber (Keyboard) Handles Terminal housing Rubber cup Rubber (lateral cover)	Rubber (Keyboard) Handles Rubber cup Rubber (lateral cover)	Test 2: Terminal housing: housing gets doughy
Blu Diesel	Rubber (Keyboard) Handles Terminal housing Rubber cup Rubber (lateral cover)	Handles Terminal housing Rubber cup Rubber (lateral cover)	Test 2: Rubber (Keyboards): rubber gets doughy
Silicone Spray	Rubber (Keyboard) Handles Terminal housing Rubber cup Rubber (lateral cover)	Rubber (Keyboard) Terminal housing Rubber cup Rubber (lateral cover)	Test 2: Handles: loss of color
Kluber CONSTANT OY 32	Rubber (Keyboard) Handles Terminal housing Rubber cup Rubber (lateral cover)	Rubber (Keyboard) Handles Terminal housing Rubber cup Rubber (lateral cover)	
Acetone	Rubber (Keyboard) Rubber (lateral cover)	Rubber (Keyboard) Rubber (lateral cover)	Test 1 and 2: Handles: loss of color Terminal housing: clouding Rubber cup: swelling
Shell Garin 9603 M15	Rubber (Keyboard) Handles Terminal housing Rubber cup Rubber (lateral cover)	Rubber (Keyboard) Handles Terminal housing Rubber cup Rubber (lateral cover)	

Touchscreen test results

Test passed with the following solvents:

- Unleaded Gasoline;
- Denatured Ethyl Alcohol;
- Diesel
- Kluber CONSTANT OY 32;
- Acetone.

2.5.2 Cable connections

Ethernet version

Ethernet Tx+ (Shielded Twisted Pair)	White/Green
Ethernet Tx- (Shielded Twisted Pair)	Green
Ethernet Rx- (Shielded Twisted Pair)	Orange
Ethernet Rx+ (Shielded Twisted Pair)	White/Orange
State Selector Common	Red/Blu
State Selector Bit 0	Grey/Pink
State Selector Bit 1	Yellow/White
State Selector Bit 2	White/Green
State Selector Bit 3	Brown/Green
Enabling Device N.O. Contact 1	Yellow
Enabling Device N.O. Contact 1	Green
Enabling Device N.O. Contact 2	White
Enabling Device N.O. Contact 2	Brown
Power Supply GND	Blue
Power Supply 24V	Red
Stop Button N.C. Contact 1	Black
Stop Button N.C. Contact 1	Pink
Stop Button N.C. Contact 2	Purple
Stop Button N.C. Contact 2	Grey

RS-422 Serial Version

Serial RS-422 Tx+ (Shielded Twisted Pair)	Yellow
Serial RS-422 Tx- (Shielded Twisted Pair)	Green
Serial RS-422 Rx- (Shielded Twisted Pair)	Pink
Serial RS-422 Rx+ (Shielded Twisted Pair)	Grey
State Selector Common	Yellow/Brown
State Selector Bit 0	Yellow/White
State Selector Bit 1	Grey/Brown
State Selector Bit 2	White/Green
State Selector Bit 3	Brown/Green
Enabling Device N.O. Contact 1	White/Orange
Enabling Device N.O. Contact 1	Grey/White
Enabling Device N.O. Contact 2	Red/Blu
Enabling Device N.O. Contact 2	Blu
Power Supply GND	Brown
Power Supply 24V	White
Stop Button N.C. Contact 1	Black
Stop Button N.C. Contact 1	Grey/Pink
Stop Button N.C. Contact 2	Purple
Stop Button N.C. Contact 2	Red

2.5.3 Cable connector specifications and pin-out

H3 handheld terminal cable will terminate optionally with a DB25 male connector, with a circular male plug or with no connector.

Both the DB25 connector and the circular plug provide a metal backshell internally connected to the cable external and internal shieldings and to the handheld terminal Ground. This will let H3 terminal ground and shieldings to be connected with the machine cabinet “earth”.

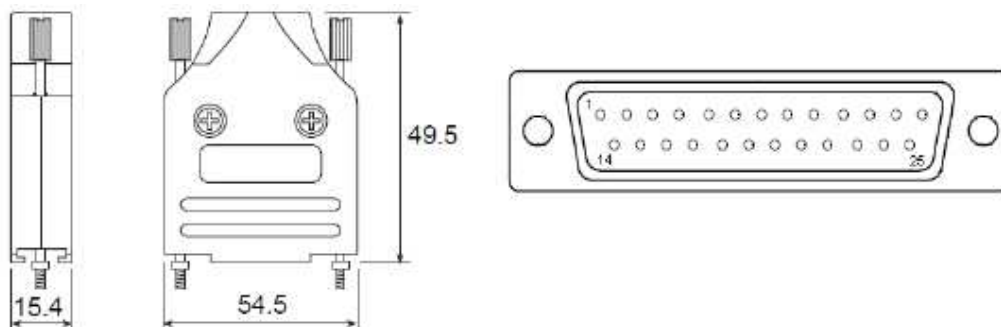

Figure 14: DB25 male connector (dimensions in millimeters)

2.5.3.1 DB25 connector pin-out

Signal	Pin
Not connected	1
Not connected	2
RS-422/Ethernet TX+	3
RS-422/Ethernet TX-	4
RS-422/Ethernet RX-	5
RS-422/Ethernet RX+	6
State Selector (common)	7
State Selector (bit 0)	8
State Selector (bit 1)	9
State Selector (bit 2)	10
State Selector (bit 3)	11
Enabling Device C1 contact (normally open)	12
Enabling Device C1o contact (normally open)	13
Enabling Device C2 contact (normally open)	14
Enabling Device C2o contact (normally open)	15
Not connected	16
Shield (Ground)	17
Not connected	18
Power Supply 0V dc (GND)	19
Power Supply +24V dc	20
Not connected	21
Emergency Stop Button C1a (normally closed)	22
Emergency Stop Button C1b (normally closed)	23
Emergency Stop Button C2a (normally closed)	24
Emergency Stop Button C2b (normally closed)	25

2.5.4 Safety-related devices

2.5.4.1 Emergency Stop button

Characteristics	Value
Switchable nominal voltage Switchable nominal current	24VDC \pm 25% 2A (DC-12 resistive load) 1A (DC-13 inductive load)
Reliability: <ul style="list-style-type: none"> • Mechanical life • Electrical life • Maximum operating frequency 	250000 operations minimum 250000 operations minimum 900 operations/hour

2.5.4.2 Enabling device

Characteristics	Value
Switchable nominal voltage Switchable nominal current	24VDC \pm 25% 1A (DC-12 resistive load) 0.7A (DC-13 inductive load)
Reliability: <ul style="list-style-type: none"> • Mechanical life • Electrical life • Maximum operating frequency 	Position 1 \rightarrow 2: 1000000 operations minimum Position 1 \rightarrow 2 \rightarrow 3 \rightarrow 1: 100000 operations minimum 100000 operations minimum 1200 operations/hour

2.5.4.3 State Selector

Characteristics	Value
Switchable nominal voltage Continuous (Non-switching) current capacity	24VDC \pm 25% 200mA
Reliability: <ul style="list-style-type: none"> • Electrical life 	25000 operations minimum

2.6 Connection box cabling scheme

The Connection Box, as shown in picture 18, is divided in two parts:

- Terminal Side (upper part): for interfacing H3 terminal to the Connection Box;
- Controller Side (lower part): for interfacing the Connection Box to the machine NC/PLC.

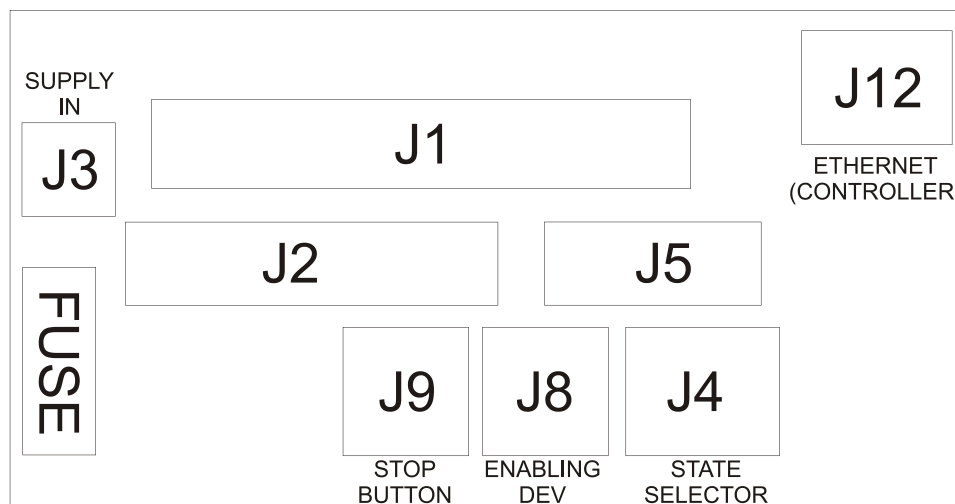

Figure 15: Connection Box TOP view

Connectors J6, J7, J10, J11 are not used.

Connection Box features a 0.25A slow-blow fuse (F1).

Caution!

- In case of F1 fuse break, please replace only with a 0.25A slow-blow fuse (size 20mm x 5mm). Fuse type example: Littlefuse 0218.250HXP.

2.6.1 Cabling: H3 to Connection Box

Open connection

User must connect cable wires to the terminal J1. For a correct cabling please refer to the following table:

VERSION	RS-422
Wire Connection	Connection Box J1
Yellow	3
Green	4
Pink	5
Grey	6
Yellow/Brown	7
Yellow/White	8
Grey/Brown	9
White/Green	10
Brown/Green	11
White/Orange	12
Grey/White	13
Red/Blu	14
Blu	15
Brown	19
White	20
Black	22
Grey/Pink	23
Purple	24
Red	25

VERSION	ETHERNET
Wire Connection	Connection Box J1
White/Green	3
Green	4
Orange	5
White/Orange	6
Red/Blu	7
Grey/Pink	8
Yellow/White	9
White/Green	10
Brown/Green	11
Yellow	12
Green	13
White	14
Brown	15
Blue	19
Red	20
Black	22
Pink	23
Purple	24
Grey	25

Both external and internal cable shieldings (copper braids) should be connected to J4 "Shield" pin.

DB-25 termination

User must connect H3 DB-25 male connector to J14 female connector.

2.6.2 Cabling: Connection Box to CN/PLC

For a correct cabling please refer to the following table:

Connection Box output contact Enabling Device	Signal meaning	Note
Terminal J8 - C1 Terminal J8 - C1o	Contact C1	N.O. Contact
Terminal J8 - C2 Terminal J8 - C2o	Contact C2	N.O. Contact
Emergency Stop Push-button		
Terminal J9 - C1a Terminal J9 - C1b	Contact C1	N.C. Contact
Terminal J9 - C2a Terminal J9 - C2b	Contact C2	N.C. Contact
State Selector		
Terminal J4 - COM	Common Contact	
Terminal J4 - 0	Bit 0	
Terminal J4 - 1	Bit 1	
Terminal J4 - 2	Bit 2	
Terminal J4 - 3	Bit 3	
RS-422 Interface (H3 RS-422 version only)		
Terminal J5 - TX+	Serial Port TX +	
Terminal J5 - TX-	Serial Port TX -	
Terminal J5 - RX+	Serial Port RX +	
Terminal J5 - RX-	Serial Port RX -	
Terminal J5 - GND	Serial Port GND	
ETHERNET interface (H3 ETHERNET version only)		
RJ45 connector J12	Ethernet Port	
Power Supply		
Terminal J13 - 24V	Power Supply 24V	
Terminal J13 - GND	Power Supply GND	
Terminal J13 - Earth	Machine Earth Ground	

2.7 Standards

H3 handheld terminal has been designed in order to conform to the following european directives and international standards:

2.7.1 EC Directives

Directive	Description
2004/108/EC	Electromagnetic Compatibility Directive (EMC)

2.7.2 International Safety Standards

Standard	Description
EMC	
EN 61000-6-2	Electromagnetic Compatibility (EMC) Part 6-2: Generic Standards - Immunity for Industrial Environments
EN 61000-6-4	Electromagnetic Compatibility (EMC) Part 6-4: Generic Standards - Emission for Industrial Environments

Degrees of protection and environmental tests	
EN 60529 + A1	Degrees of protection provided by enclosures (IP code)
Emergency Stop Push-button conforming to:	
IEC 60947-5-5, 6.2	Safety Lock Mechanism
IEC 60947-5-5, 5.2	
IEC 60947-5-1, Annex K	Direct opening action mechanism
EN ISO13850, 4.2, 4.3, 4.4	
Enabling Device conforming to:	
IEC 60947-5-1	
EN 60947-5-1	
JIS C8201-5-1	
UL508	
CSA C22.2 No 14	
IEC 60947-5-8	Low-voltage switchgear and controlgear