

## MVX9000 Adjustable Frequency Drives

Technical Data

MVX9000 Drives

Supersedes December 2002



**Model MVX9000**

### Product Description

Model MVX9000 sensorless vector adjustable frequency AC Drives are designed to provide adjustable speed control of 3-phase motors. These microprocessor-based, sensorless vector drives have standard features that can be programmed to tailor the drive's performance to suit a wide variety of application requirements.

The MVX9000 sensorless vector product line utilizes a 32-bit microprocessor and insulated gate bipolar transistors (IGBTs) which provide quiet motor operation, high motor efficiency and smooth low speed performance. The size and simplicity of the MVX9000 make it ideal for hassle free installation where size is a primary concern.

Models rated at 480 volts, 3-phase, 50/60 Hz are available in sizes ranging from 1 to 10 hp. Models rated at 240 volts, single- or 3-phase, 50/60 Hz are available in sizes ranging from 1/2 to 7-1/2 hp.

The standard drive includes a digital display, operating and programming keys on a removable keypad.

### Contents

<i>Description</i>	<i>Page</i>
<b>Product Description</b> . . . . .	<b>1</b>
<b>Features and Benefits</b> . . . . .	<b>1</b>
<b>Technical Data and Specifications</b> . . . . .	<b>2</b>
<b>Wiring Diagrams</b> . . . . .	<b>3</b>
<b>Dimensions</b> . . . . .	<b>5</b>
<b>Catalog Number Selection</b> . . . . .	<b>6</b>
<b>Product Selection</b> . . . . .	<b>6</b>

The display provides drive monitoring as well as adjustment and diagnostic information. The keys are utilized for digital adjustment and programming of the drive as well as for operator control. Separate terminal blocks for control and power wiring are provided for customer connections. Other features provided as standard include built-in DC braking, RS-485 serial communications and PID control.

### Features and Benefits

**Table 1. Features and Benefits**

<b>Feature</b>	<b>Customer Benefit</b>
Sensorless Vector Control with auto tuning.	Provides 200% starting torque and advanced low speed torque control.
Clearly laid out and easy to understand keypad with 4-character LED display, 7 status indicating LEDs, speed potentiometer, and 6 function keys.	Most informative operator's interface in this class of VFD, provided as standard. All parameters, diagnostic information and metering values are displayed with a bright 4-character LED display.
2 analog inputs 6 programmable, intelligent digital inputs 1 programmable digital output 1 programmable relay	Provide enhanced application flexibility.
PID control of a process variable such as pressure, flow, temperature, liquid level, etc.	Eliminates requirement for separate setpoint controller.
Built-in dynamic braking chopper.	Superior deceleration performance.
Serial communication port (RS-485).	Direct connection to serial communications networks.
Single-phase or three-phase input capability on 240V AC rated units, 3 hp and below.	Operate three-phase motor with single-phase supply.

## Technical Data and Specifications

### Output Ratings

- Horsepower;
  - 200 – 240V: 1/2 – 7-1/2 hp
  - 380 – 480V: 1 – 10 hp
- Frequency Range: 0.1 – 400 Hz
- Overload Rating: 150% for 60 seconds
- Frequency Resolution:
  - Digital: 0.1 Hz
  - Analog: Max. (Set Frequency/1000) Hz
- Frequency Accuracy
  - Digital: ± 0.01% of max. frequency
  - Analog: ± 0.2% of max. frequency
- Undervoltage Carryover Limit: 0.3 to 25 seconds

### Motor Performance

- Motor Control: Sensorless Vector
- Constant and Variable Torque: Standard
- Speed Regulation: 0.5% of base speed

### Input Power

- Voltage at 50/60 Hz ± 3 Hz
  - 200V – 240V, -10% +5% / 1-phase
  - 200V – 240V, -10% +5% / 3-phase
  - 380V – 480V, -10% +10% / 3-phase
- Displacement Power Factor: Better than 0.95
- Efficiency: Typically greater than 95%

### Design Type

- Microprocessor: 32-Bit
- Converter Type: Diode
- Inverter Type: Insulated Gate Bipolar Transistor
- Waveform: Sensorless Vector

### Environment

- Operating Temperature:
  - -10°C to +50°C
  - -10°C to +40°C (above 7-1/2 hp)
- Humidity: 20 to 90% non-condensing
- Maximum Elevation: 1000 meters (3300 ft.)

### Codes and Standards

- NEMA, IEEE, NEC: Design Standards
- UL Listed
- cUL Listed
- CE Marked (Requires EMI filter)

### Enclosure

- Standard: Protected Chassis (IP20)

### Protective Features

- Ground Fault: Standard
- Overload Protection: Standard
- Overcurrent: Standard
- Overvoltage: Standard
- Undervoltage: Standard
- Overtemperature: Standard
- Overload Limit: Standard

### Set Up Adjustments, Performance Features, Operator Control and External Interface

#### Keypad

- Alphanumeric Display: Standard, 1 x 4 character
- Digital Indications: Frequency (Hz), Motor Current (amps), User-Defined RUN/STOP, FORWARD/REVERSE and Parameters
- Diagnostics: Last 3 trips with cause
- LED Status Indicators: 8 (RUN/STOP, FORWARD/REVERSE, Hz, Amps, User Defined, and Input Speed)
- Operator Functions: START/STOP, Speed control (digital or potentiometer), RESET, SETUP Keys and ENTER.

#### I/O Terminal Block

- Analog Inputs:
  - 2 Inputs: 0 – 10V DC, 4 – 20 mA
  - Potentiometer: 1K ohm to 2K ohm
  - Analog Voltage: Nominal 10V DC (10K ohm input impedance)
  - Analog Current: Nominal 4 – 20 mA (250 ohm)
- Digital Inputs: 6 Programmable Inputs
- Digital Outputs: 1 Programmable Open collector and 1 Form C Relay contact

- Analog Monitor Output:
  - Analog meter – frequency or output current

#### Programmable Parameters

- Out of the Box: Factory settings loaded for quick start-up.
- Accel. and Decel.: 2 separately adjustable Linear or S Curve times: 0.1 – 3000 seconds

- Auto Restart: Overcurrent, overvoltage and undervoltage with 4 selectable retry restart modes
- DC Braking: Standard Built-In
- External Fault: Terminal input
- Jog: Terminal input
- Fault Reset: STOP/RESET or terminal input
- I/O: NO/NC Selectable
- Jump Frequencies: 3 (with adjustable width)
- Parameter Security: Programmable software lock
- Preset Speeds: 7 preset speeds
- PID Controller: PID process control
- Reversing: Keypad or terminal
- Speed Setting: Keypad, terminal or pot
- START/STOP Control: Keypad or terminal
- Stop Modes: Decel, coast or DC injection

#### Reliability

- Pretested Components: Standard
- Surface Mount Technology: Standard (PCBs)
- Computerized Testing: Standard
- Final Test with Full Load: Standard
- Eaton's Cutler-Hammer Engineering Systems and Service: National network of AF drive specialists

Table 2. Watts Loss

Horsepower	Catalog Number	Volts	Watts Loss
			9 kHz
1/2	MVXF50A0-2	230V AC	20W
1	MVX001A0-2		38W
2	MVX002A0-2		75W
3	MVX003A0-2		110W
5	MVX005A0-2		185W
7-1/2	MVX007A0-2		275W
1	MVX001A0-4	480V AC	38W
2	MVX002A0-4		75W
3	MVX003A0-4		110W
5	MVX005A0-4		185W
7-1/2	MVX007A0-4		275W
10	MVX010A0-4		375W

**Table 3. Dynamic Braking Resistor Sizing**

Dynamic Braking Resistors, Open Units		Catalog Number	No. of Units Used	Resistor (Ohms)	Watts	Braking Torque	Duty Cycle
Horsepower	Volts						
1/2	230V Series	K13-000034-0821	1	100	80W	220%	10%
1		K13-000034-0821	1	80	80W	125%	10%
2		K13-000034-0824	1	55	300W	125%	10%
3		K13-000034-0824	1	35	300W	125%	10%
5		K13-000034-0825	1	25	400W	125%	10%
7-1/2		K13-000034-0826	2	16	250W	125%	10%
1	460V Series	K13-000034-0841	1	260	80W	125%	10%
2		K13-000034-0843	1	190	300W	125%	10%
3		K13-000034-0843	1	145	300W	125%	10%
5		K13-000034-0844	1	95	400W	125%	10%
7-1/2		K13-000034-0845	2	60	250W	125%	10%
10		K13-000034-0846	3	45	350W	125%	10%

**Wiring Diagrams**

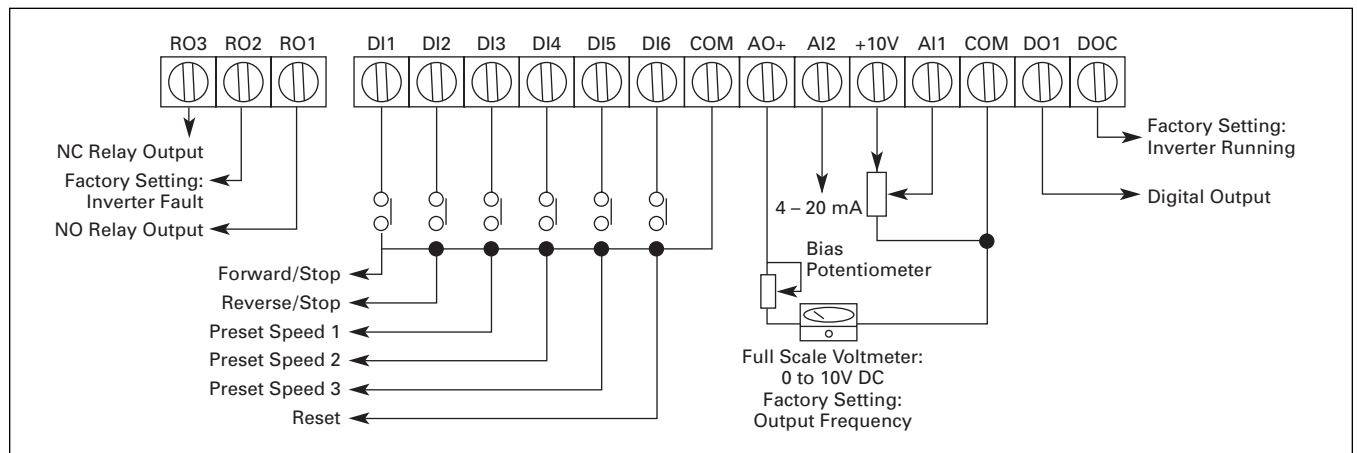

**Figure 1. Control Terminal Wiring (Factory Settings)**

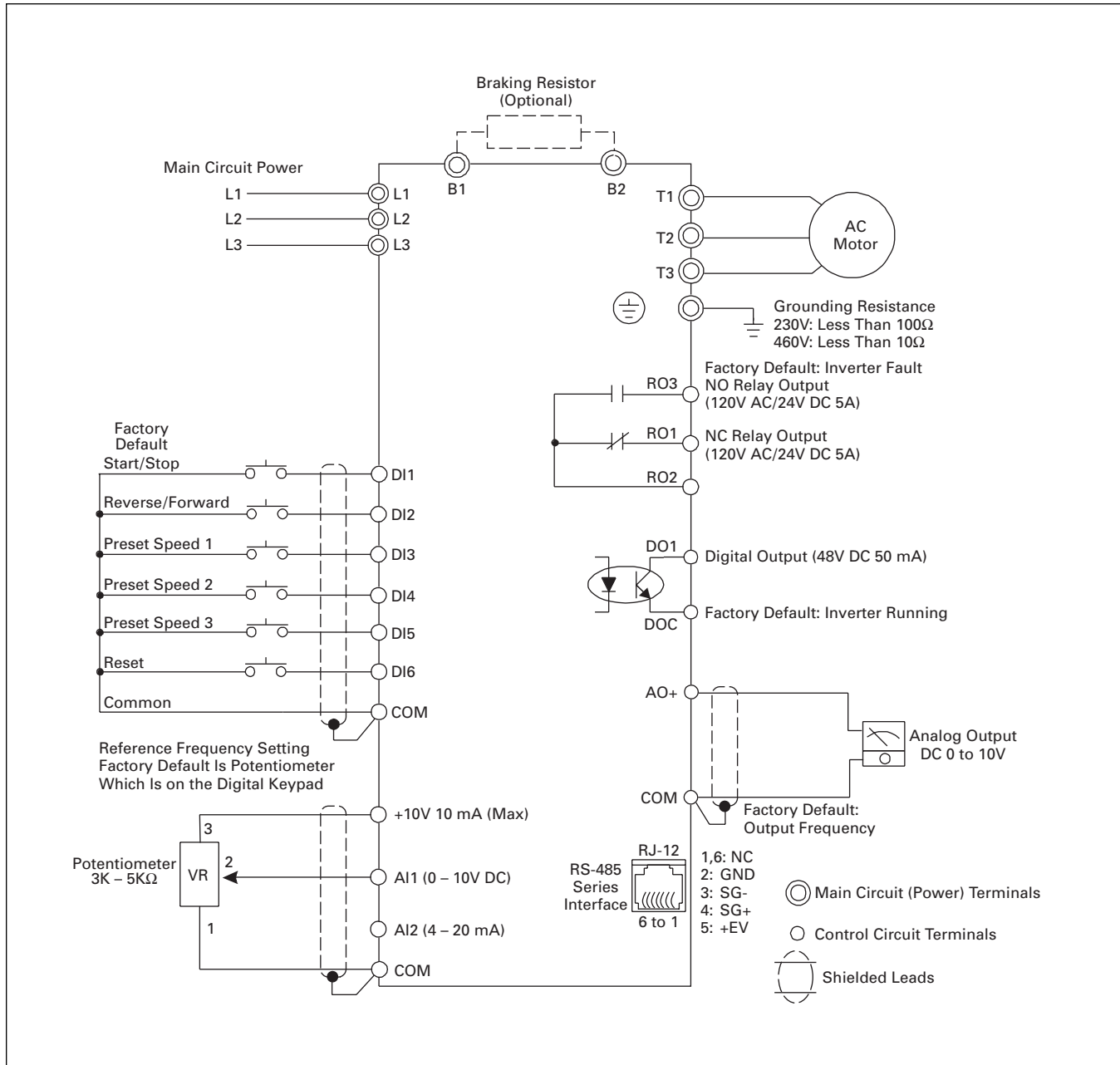

**Figure 2. Basic Wiring Diagram**

**Note:** Do not plug a modem or telephone line to the RS-485 communication port, permanent damage may result. Terminal 2 and 5 are the power sources for the optional copy keypad and should not be used while using RS-485 communication.

■ For single-phase application select correct model, and select any of the two input terminals for main circuit power.

**Dimensions**

**Table 4. Approximate Dimensions and Shipping Weights for Basic Controller**

Description		Dimensions in Inches (mm)			Shipping Weight Lbs. (kg)
Horsepower	Volts	Width	Height	Depth	
1/2	200 – 240	3.9 (100)	5.9 (151)	5.7 (145)	6.2 (2.8)
1		3.9 (100)	5.9 (151)	5.7 (145)	6.2 (2.8)
2		3.9 (100)	5.9 (151)	5.7 (145)	6.2 (2.8)
3		4.9 (100)	8.6 (220)	7.6 (193)	12.1 (5.5)
5		4.9 (125)	8.6 (220)	7.6 (193)	12.1 (5.5)
7-1/2		4.9 (125)	8.6 (220)	7.6 (193)	12.1 (5.5)
1	380 – 480	3.9 (100)	5.9 (151)	5.7 (145)	6.2 (2.8)
2		3.9 (100)	5.9 (151)	5.7 (145)	6.2 (2.8)
3		3.9 (100)	5.9 (151)	5.7 (145)	6.2 (2.8)
5		4.9 (125)	8.6 (220)	7.6 (193)	12.1 (5.5)
7-1/2		4.9 (125)	8.6 (220)	7.6 (193)	12.1 (5.5)
10		4.9 (125)	8.6 (220)	7.6 (193)	12.1 (5.5)

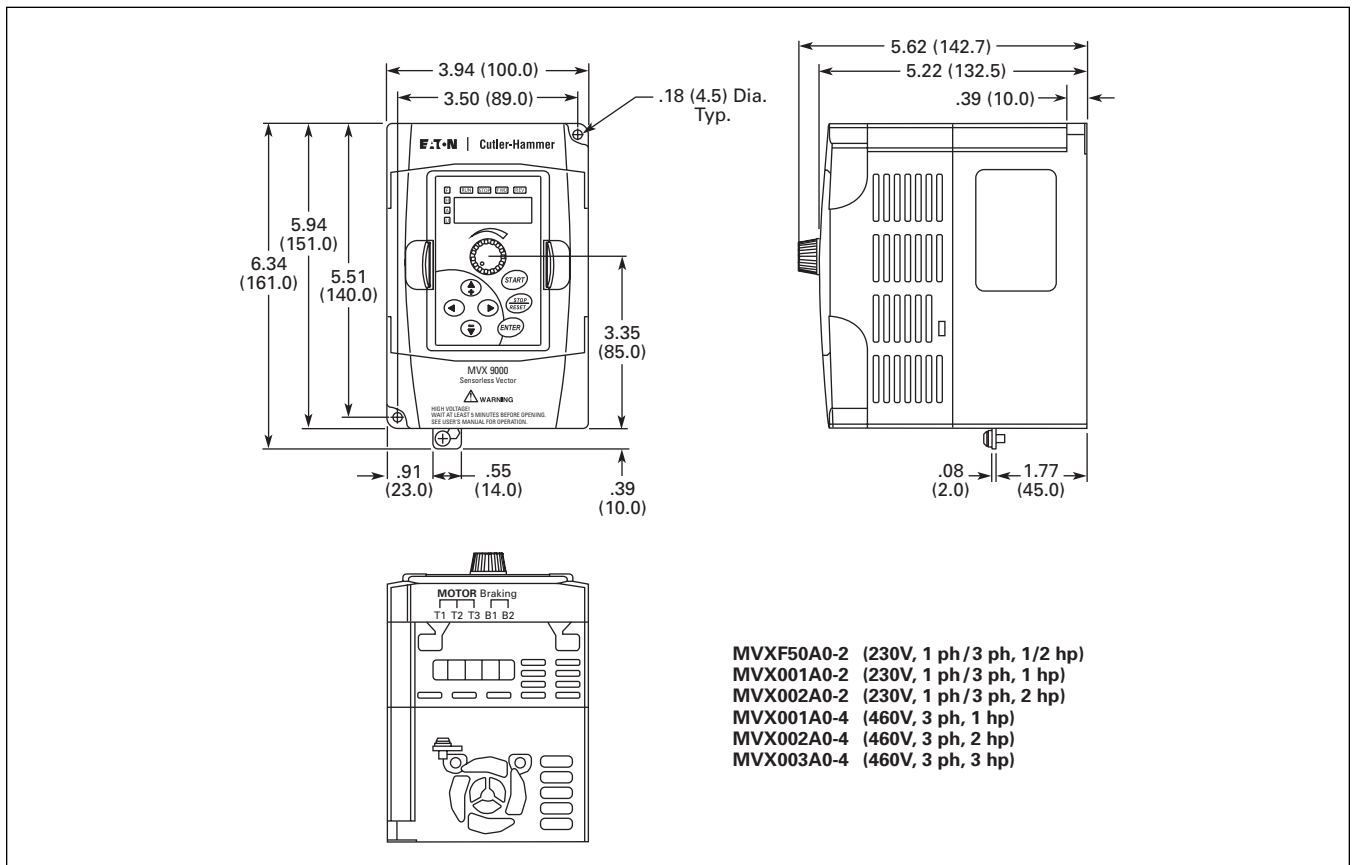

**Figure 3. 1/2 to 3 hp Drive Approximate Dimensions in Inches (mm)**

- MVXF50A0-2 (230V, 1 ph/3 ph, 1/2 hp)
- MVX001A0-2 (230V, 1 ph/3 ph, 1 hp)
- MVX002A0-2 (230V, 1 ph/3 ph, 2 hp)
- MVX001A0-4 (460V, 3 ph, 1 hp)
- MVX002A0-4 (460V, 3 ph, 2 hp)
- MVX003A0-4 (460V, 3 ph, 3 hp)

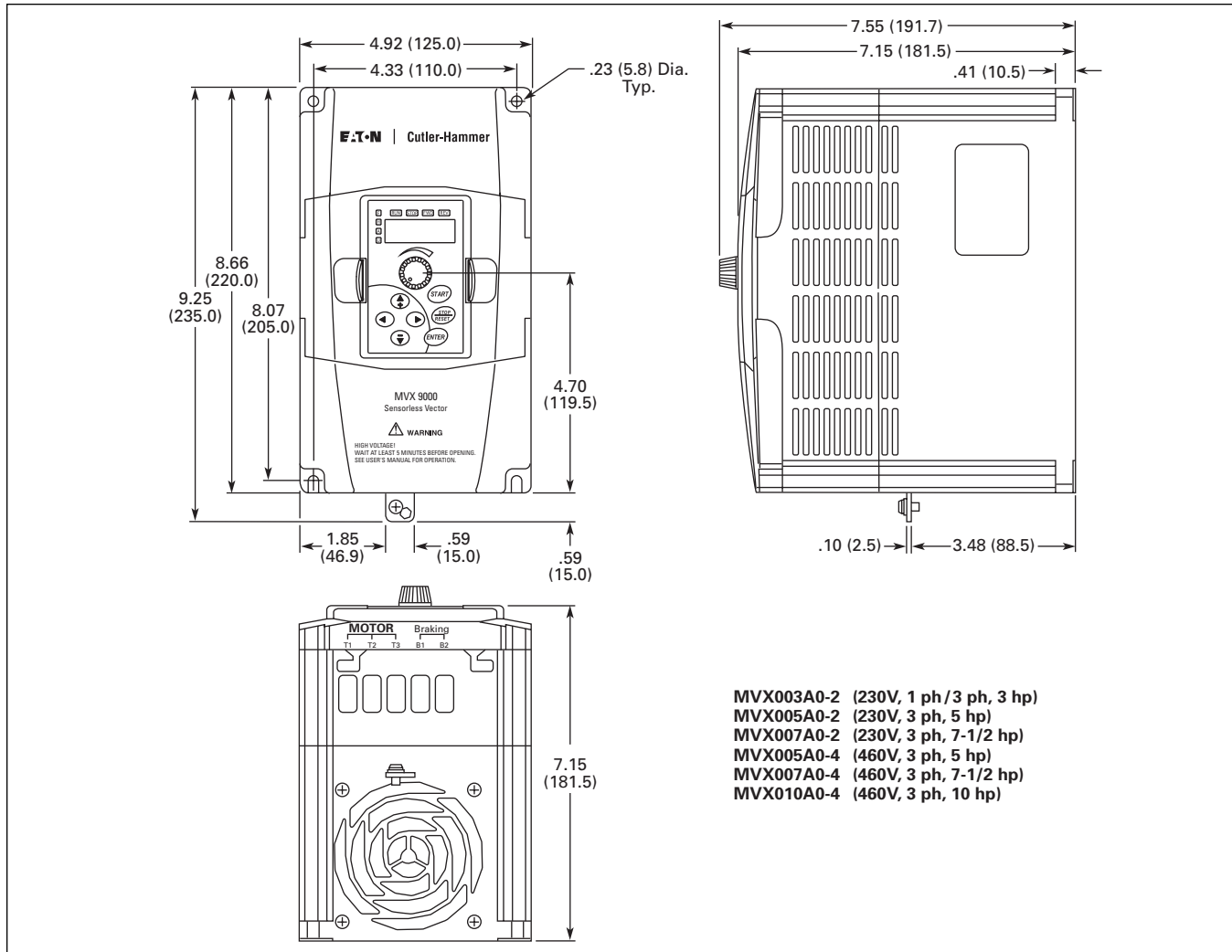

- MVX003A0-2 (230V, 1 ph/3 ph, 3 hp)
- MVX005A0-2 (230V, 3 ph, 5 hp)
- MVX007A0-2 (230V, 3 ph, 7-1/2 hp)
- MVX005A0-4 (460V, 3 ph, 5 hp)
- MVX007A0-4 (460V, 3 ph, 7-1/2 hp)
- MVX010A0-4 (460V, 3 ph, 10 hp)

Figure 4.3 to 10 hp Drive Approximate Dimensions in Inches (mm)

Catalog Number Selection

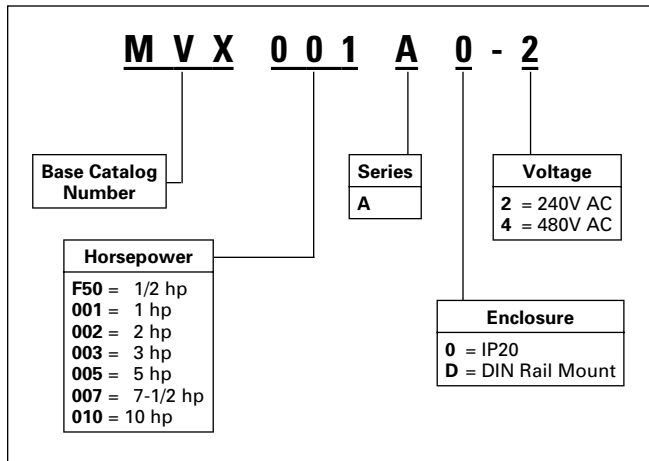

Product Selection

Table 5. MVX9000 Basic Controller IP20

Description	Input Ampere	Continuous Output	Catalog
Horsepower ①	Volts ②	Single-/Three-Phase Rating	Number
1/2	200 – 240	6.3/2.9	2.5
1		11.5/6.3	5.0
2		15.7/8.8	7.0
3		27.5/12.5	10
5		—/19.6	17
7-1/2		—/31.5	25
1	380 – 480	—/4.2	3.0
2		—/5.7	4.0
3		—/7.0	5.0
5		—/8.5	8.2
7-1/2		—/14	13
10		—/20.6	18

- ① Horsepower ratings are based on the use of a 230V or 460V NEMA B, 4- or 6-pole squirrel cage induction motor and are for reference only. Units are to be selected such that the motor current is less than or equal to the MVX9000 rated continuous output current.
- ② For 208V, 380V or 415V applications, select the unit such that the motor current is less than or equal to the MVX9000 rated continuous output current.

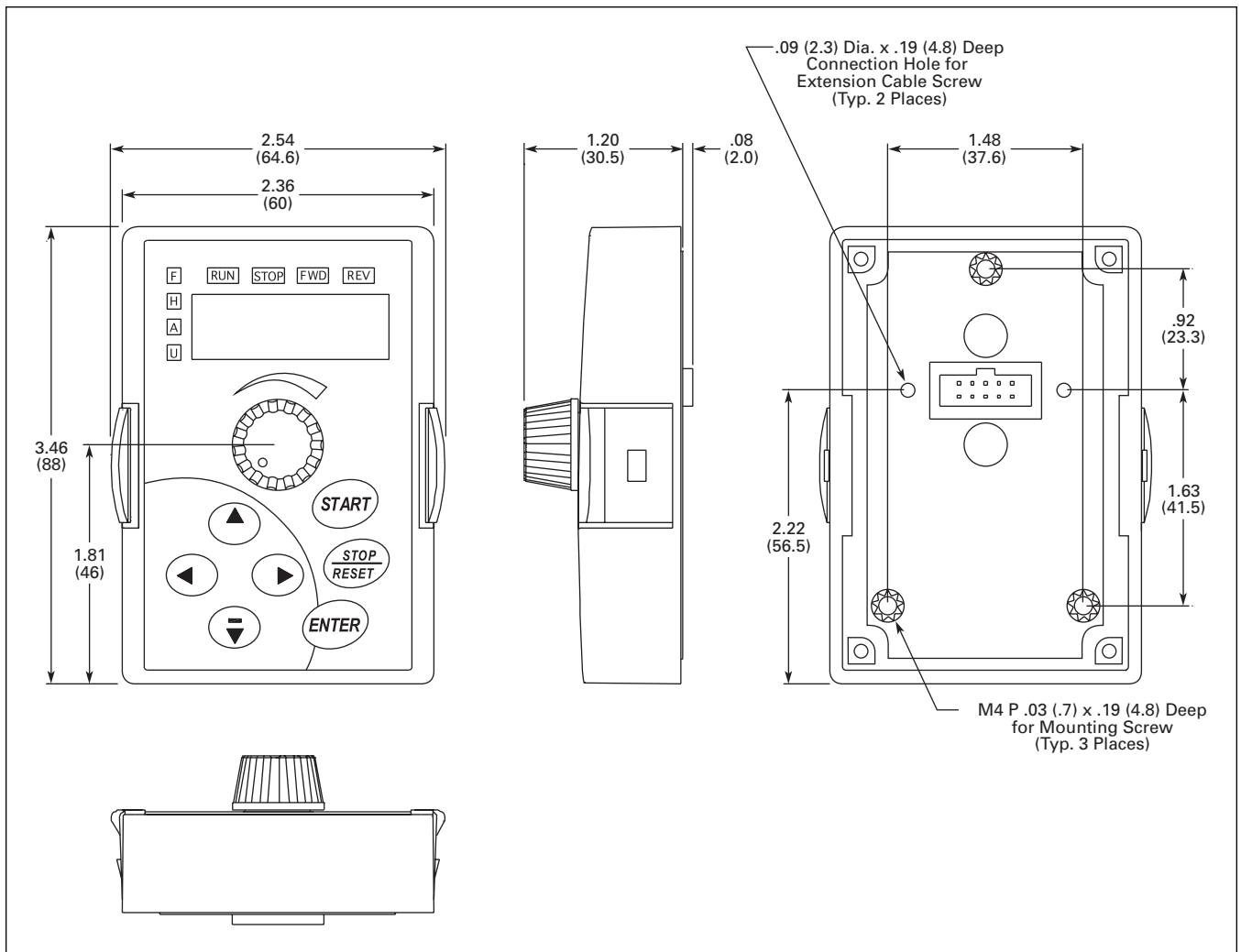

**Figure 5. Digital Keypad Approximate Dimensions in Inches (mm)**

