

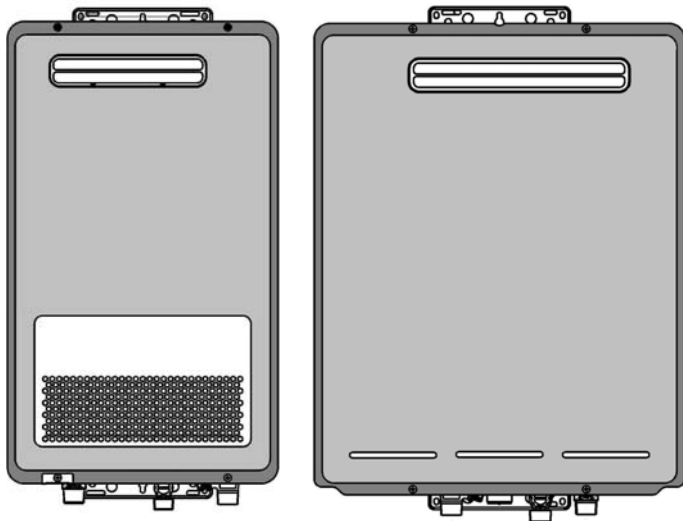

Bradford White EverHot® Tankless Gas Water Heater For Exterior Installation

TG-150E-N(X), TG-180E-N(X), TG-199E-N(X), TG237E-N(X) & TG-237E-N(X)A



Ambler, PA 19002
Tech. Service (800) 334-3393
Service Part (800) 538-2020
Warranty Service (800) 531-2111



▲ WARNING: If the information in these instructions is not followed exactly, a fire or explosion may result causing property damage, personal injury or death.

- Do not store or use gasoline or other flammable vapors and liquids in the vicinity of this or any other appliance
- WHAT TO DO IF YOU SMELL GAS**
 - Do not try to light any appliance.
 - Do not touch any electrical switch; do not use any phone in your building.
 - Immediately call your gas supplier from a neighbor's phone. Follow the gas supplier's instructions.
 - If you cannot reach your gas supplier, call the fire department.
- Installation and service must be performed by a qualified installer, service agency, or gas supplier.

INSTALLATION AND OPERATION INSTRUCTION MANUAL

With Troubleshooting Guide

PLACE THESE INSTRUCTIONS ADJACENT TO WATER HEATER AND NOTIFY OWNER TO KEEP FOR FUTURE REFERENCE

A Spanish language version of these instructions is available by contacting Bradford White.
La versión española de estas instrucciones se puede obtener al escribirle a la fábrica cuyo nombre aparece en la placa de.

SECTION I: IMPORTANT INFORMATION

READ CAREFULLY

This gas-fired water heater is design certified by CSA International under the American National Standard, Z21.10.3 (as indicated on the rating plate) and CAN/CGA 4.3-M (as indicated on the rating plate) available from CSA Standards Association, 5060 Spectrum Way, Mississauga, Ontario, Canada L4W 5N6.

This water heater must be installed in accordance with local codes. In the absence of local codes, it must be installed in compliance with the National Fuel Gas Code (ANSI Z223.1-Latest Edition), or in Canada CAN/CGA B149.1 Natural Gas Installation Code (Latest Edition) or CAN/CGA B149.2 Propane Installation Code (Latest Edition).

The following terms are used throughout this manual to bring attention to the presence of hazards at various risk levels, or to important information concerning product life.

DANGER

Indicates an imminently hazardous situation, which, if not avoided, will result in death, serious injury or substantial property damage.

CAUTION

Indicates potentially hazardous situation, which, if not avoided, may result in moderate or minor injury or property damage.

WARNING

Indicates a potentially hazardous situation, which, if not avoided, could result in death, serious injury or substantial property damage.

NOTICE

Indicates special instructions on installation, operation or maintenance, which are important but not related to personal injury hazards.

NOTICE

This water heater has a limited warranty. The warranty for this water heater is valid only if the water heater has been installed, maintained, and operated in accordance with these instructions.

TABLE OF CONTENTS

I	IMPORTANT INFORMATION	2	VII	OPERATING INSTRUCTIONS.....	40
II	SPECIFICATIONS	6		TEMPERATURE	
				ADJUSTMENT.....	42
III	INSTALLATION		VIII	MAINTENANCE.....	47
	INSTRUCTIONS	9			
IV	WATER CONNECTIONS.....	17	IX	PARTS LIST	51
V	GAS CONNECTIONS	26	X	WARRANTY	67
VI	ELECTRICAL CONNECTIONS.....	29			

DANGER

DO NOT store or use gasoline or other flammable, combustible, or corrosive vapors and/or liquids in the vicinity of this or any other appliance.

This water heater is for outdoor installation only. Do not install indoors.

This water heater is equipped with an adjustable thermostat to control water temperature. Hot water temperatures required for automatic dishwasher and laundry use can cause scald burns resulting in serious personal injury and/or death. The temperature at which injury occurs varies with the person's age and the time of exposure. The slower response time of disabled persons increases the hazards to them. NEVER allow small children to use a hot water tap, or to draw their own bath water. NEVER leave a child or disabled person unattended in a bathtub or shower.

WARNING

Improper installation, adjustments, alteration, service or maintenance can cause property damage, personal injury or loss of life. Failure to follow all instructions in the proper order can cause personal injury or death. Read and understand all instructions, including all those provided with the appliance before installing, starting-up, operating, maintaining or servicing this appliance. Keep this manual and literature in legible condition with this water heater for reference by owner and service technician.

This water heater requires regular maintenance and service to operate safely. Follow the instructions contained in this manual.

Installation, maintenance, and service must be performed only by a qualified, skilled and knowledgeable installer or service provider.

Installation is not complete unless a pressure relief valve is installed into the proper location in the hot water outlet piping of this water heater.

It is the responsibility of the installing contractor to see that all controls are correctly installed and are properly operating when the installation is complete.

This water heater is NOT suitable for installation on combustible flooring. Install water heater exactly as shown in this manual.

DO NOT operate this water heater without first being certain it is filled with water.

 **WARNING**

DO NOT tamper with or alter the water heater and/or controls.

DO NOT operate water heater with jumpered or absent controls or safety devices.

DO NOT operate water heater if any external part has been under water. Immediately call a qualified service technician to inspect the water heater and to replace any part of the control system including gas controls, which has been under water.

DO NOT attempt to use this water heater with any gas other than the type listed on the rating plate. Do not attempt to convert this water heater for use with a gas other than the type for which it is equipped. Failure to use the proper gas can create an unsafe condition resulting in property damage, bodily injury, or death. Consult your local gas supplier or gas company if there are any questions.

DO NOT operate this water heater if the input rate exceeds the rate shown on the water heater rating plate.

This water heater contains very hot water under high pressure. Do not unscrew any pipe fittings nor attempt to disconnect any components of this water heater without positively assuring the water is cool and is not under pressure. Always wear protective clothing and equipment when installing, starting up or servicing this water heater to prevent scald injuries. Do not rely on the temperature gauges to determine the temperature. Do not touch any components unless they are cool.

Water heater materials of construction, products of combustion and the fuel contain carbon monoxide, nitrogen oxides, aldehydes and/or other toxic or harmful substances which can cause death or serious injury and which are known to the state of California to cause cancer, birth defects and other reproductive harm. Always use proper safety clothing, respirators and equipment when servicing or working nearby this water heater.

 **WARNING**

Liquefied petroleum gases/propane gas is heavier than air and will remain at floor level if there is a leak. Basements, crawl spaces, closets and areas below ground level will serve as pockets for accumulation of leaking gas. Before lighting, smell all around the appliance area for gas. Be sure to smell next to the floor.

IF YOU SMELL GAS:

- DO NOT try to light any appliance.
- DO NOT touch any electric switch; do not use any telephone in your building.
- Immediately call your gas supplier from a telephone in another building. Follow the gas supplier's instructions.
- If you cannot reach your gas supplier, call the fire department.

DO NOT OPERATE THE APPLIANCE UNTIL THE LEAKAGE IS CORRECTED!

 **WARNING**

Flammable items, pressurized containers or any other potential fire hazardous articles must never be placed on or adjacent to the water heater. Open containers of flammable material must not be stored or used in the same room with this water heater.

DO NOT USE AN INSULATION BLANKET WITH THIS WATER HEATER. This water heater meets or exceeds the ASHRAE/IES 90.1b (latest edition) standards with respect to insulation and standby loss requirements.

SECTION II: SPECIFICATIONS

Table 1. Specifications.

Model	TG-150E-N(X)	TG-180E-N(X)	TG-199E-N(X)	TG-237E-N(X)	TG-237E-N(X)A
Minimum Rate Btu/h	15,000			19,000	
Maximum Rate Btu/h	150,000	180,000	199,000	237,000	
Flow Rate (Min-Max) *	0.6-6.3 GPM (2.3-24 L/min)	0.6-7.5 GPM (2.3-28.4 L/min)	0.6-9.4 GPM (2.3-35.5 L/min)	0.6-9.8 GPM (2.3-37 L/min)	
Flow Rate (45°F rise)	5.5 GPM (20.8 L/min)	6.6 GPM (25.1 L/min)	7.1 GPM (27.0 L/min)	8.5 GPM (32.2 L/min)	
Default Temperature Setting	104°F (40°C)				
Maximum Temp Setting (commercial **)	160°F (71°C)		180°F (82°C)	185°F (85°C)	
Maximum Temp Setting (residential)	120°F (49°C)				
Minimum Temperature Setting	96°F (36°C)			98°F (37°C)	
Weight	46 lb (21 kg)			55 lb (25 kg)	
Energy Factor	0.82	0.82	0.82	N/A	
Thermal Efficiency	83.0%				
Noise level (inside rating)	49 dB				
Electrical Consumption	Normal	45 W	50 W	55 W	72 W
	Standby	2 W			
	Anti-frost Protection	100 W			116 W
By-Pass Control	Fixed		Electronic		
Minimum Gas Supply Pressure	Natural Gas	5.0 inch W.C.			
	Propane	8.0 inch W.C.			
Maximum Gas Supply Pressure	Natural Gas	10.5 inch W.C.			
	Propane	13.5 inch W.C.			
Type of Appliance	Temperature controlled continuous flow gas water heater				
Operation	With or without remote controls, mounted in kitchen, bathroom, etc.				
Approved Gas Type	Natural Gas or Propane-Ensure unit matches gas type supplied at the installation location.				
Connections	Gas Supply: 3/4" MNPT, Cold Water Inlet: 3/4" MNPT, Hot Water Outlet: 3/4" MNPT				
Ignition System	Direct Spark Ignition				
Electric Connections	Water Heater: AC 120 Volts, 60Hz. Remote Control: DC 12 Volts (Digital)				
Water Temperature Control	Simulation Feedforward and Feedback				
Minimum Water Supply Pressure	20 PSI (Recommended 30-80 PSI for maximum performance)				
Maximum Water Supply Pressure	150 PSI				
Remote Control Cable	Non-Polarized Two Core Cable (Minimum 22 AWG)				
ENERGY STAR® Qualified	Yes (U.S. and Canada)			No	

* Minimum flow may vary slightly depending on the temperature setting and the inlet water temperature.

** For commercial and hydronic applications requiring higher temperatures. Requires the use of an optional controller (P/N 239-47805-00).

Bradford White Corporation is continually updating and improving products. Therefore, specifications are subject to change without prior notice.

The maximum inlet gas pressure must not exceed the value specified by the manufacturer. The minimum value listed is for the purpose of input adjustment.

Dimensions

TG-150E-N(X), TG-180E-N(X), TG-199E-N(X)

TG-237E-N(X), TG-237E-N(X)A

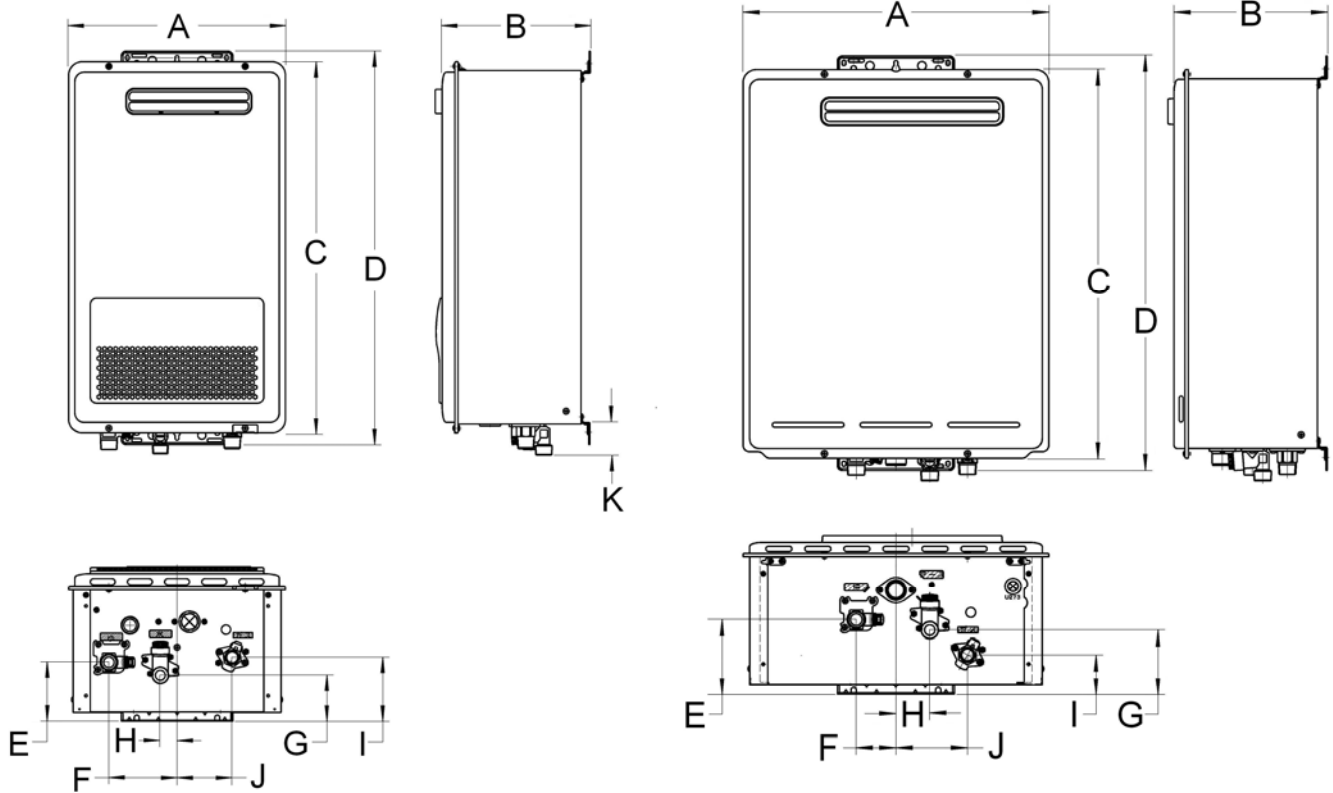

Table 2. Water Heater Dimensions.

DIM	DESCRIPTION	<i>TG-150E-N(X)</i> <i>TG-180E-N(X)</i> <i>TG-199E-N(X)</i>	<i>TG-237E-N(X)</i> <i>TG-237E-N(X)A</i>
		In. (mm)	in. (mm)
A	Width	14 (355.6)	18 1/2 (470)
B	Depth	9 7/8 (249.5)	9 3/8 (230.5)
C	Height - Unit	22 7/8 (582)	23 5/8 (600)
D	Height - with brackets	25 3/8 (646.4)	25 1/8 (640)
E	Hot Water Outlet - from wall	3 7/8 (96)	4 1/2 (115)
F	Hot Water Outlet - from center	4 3/8 (110)	2 3/8 (61)
G	Cold Water Inlet - from wall	2 5/8 (75)	3 7/8 (99)
H	Cold Water Inlet - from center	1 1/8 (27)	2 (52)
I	Gas Connection - from wall	4 1/8 (104)	2 3/8 (61.2)
J	Gas Connection - from center	3 1/2 (89)	4 3/8 (110)
K	From base to gas connection	1 5/8 (40)	1 5/8 (40)
	From base to cold connection	2 (50)	2 (50)
	From base to hot connection	1 5/8 (41)	1 5/8 (41)

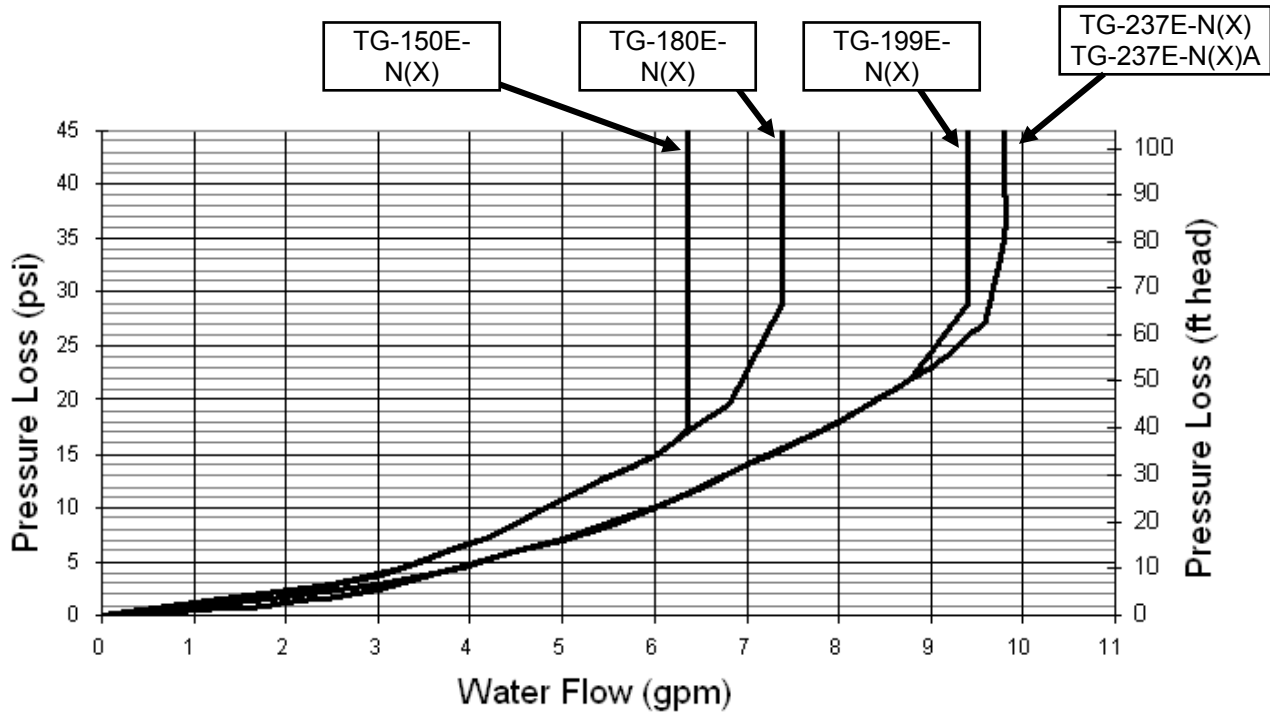

Figure 1. Graph Showing Pressure Drop v. Water Flow Rate.

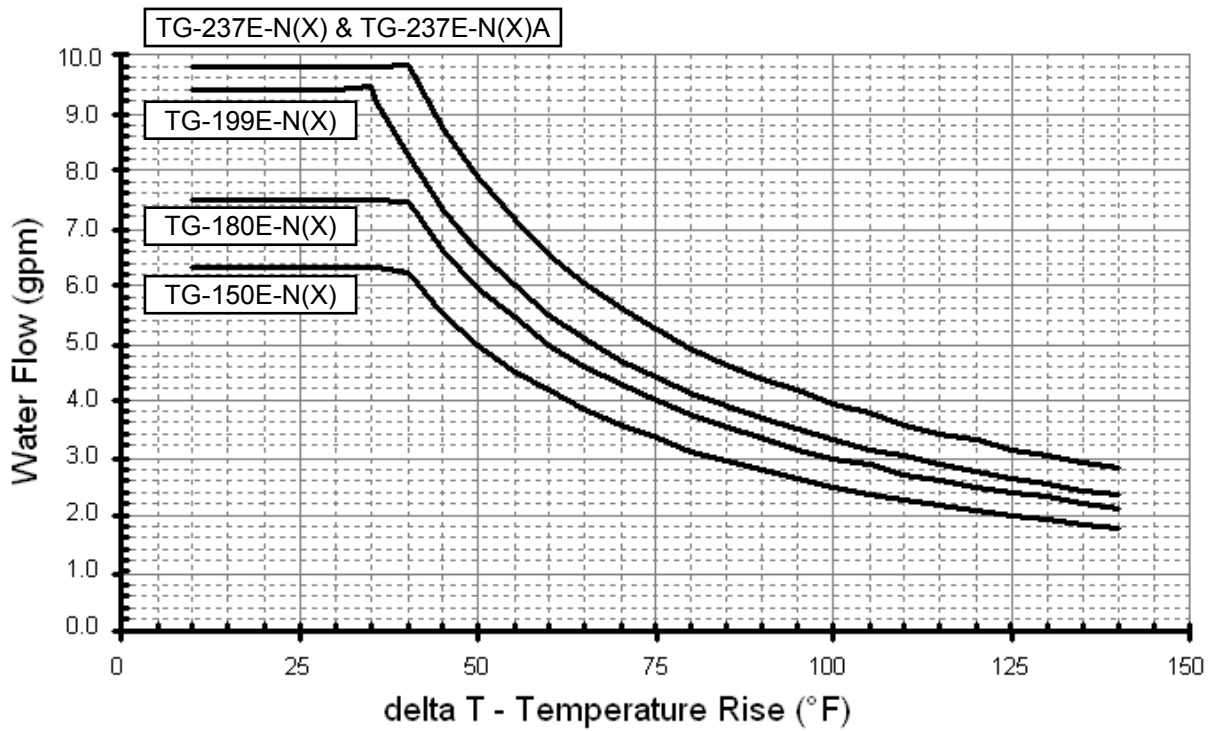

Figure 2. Graph Showing Water Flow Rate v. Temperature Rise.

SECTION III: INSTALLATION INSTRUCTIONS

WARNING

INSTALLATION OF THIS WATER HEATER REQUIRES ABILITY EQUIVALENT TO THAT OF A LICENSED PLUMBER. Plumbing, air supply, venting, gas supply and electrical work are required.

DO NOT ATTEMPT TO LIGHT ANY GAS APPLIANCE IF YOU ARE NOT CERTAIN OF THE FOLLOWING:

- Liquefied petroleum gases/propane gas and natural gas have an odorant added by the gas supplier that aids in detection of the gas.
- Most people recognize this odor as a “sulfur” or “rotten egg” smell.
- Other conditions, such as “odorant fade” can cause the odorant to diminish in intensity, or “fade”, and not be as readily detectable.
- If you have a diminished sense of smell, or are in any way unsure of the presence of gas, immediately contact your gas supplier from a telephone in another building.
- Gas detectors are available. Contact your gas supplier or plumbing professional for more information.

Liquefied petroleum gases/propane gas is heavier than air and will remain at floor level if there is a leak. Basements, crawl spaces, closets and areas below ground level will serve as pockets for accumulation of leaking gas. Before lighting, smell all around the appliance area for gas. Be sure to smell next to the floor.

IF YOU SMELL GAS:

- Do not try to light any appliance.
- Do not touch any electric switch; do not use any telephone in your building.
- Immediately call your gas supplier from a telephone in another building. Follow the gas supplier’s instructions.
- If you cannot reach your gas supplier, call the fire department.

DO NOT OPERATE THE APPLIANCE UNTIL THE LEAKAGE IS CORRECTED!

CAUTION

If building cold water supply has a back-flow preventer, check valve or water meter with check valve, provisions for thermal expansion of water in the hot water system must be provided.

WARNING

Pressure relief valve discharge piping must be piped near ground or drain to eliminate potential of severe burns. Insulate and use electrical heat tape around the discharge drain pipe in any area where freezing could occur. Do not install any shut-off valves, plugs or caps to the temperature and pressure relief valve or piping.

DANGER

Temperature setting should not exceed safe temperature at fixtures. See water temperature control warning in the “Temperature Adjustment” section of this Installation and Operation Instruction Manual. If higher preheat temperatures are necessary to obtain adequate booster output, add an ASSE approved mixing valve for hot water supplied to fixtures.

WARNING

- Residential use water heaters are suitable for potable water heating only. DO NOT use a residential use water heater for space heating or combination space heating/domestic water heating. Commercial use water heaters may be used for space heating or combination space heating/domestic water heating. Refer to the instructions for space heating in this Installation and Operation Instruction Manual.
- This water heater is not suitable for use in pool or spa applications.
- This water heater must be installed outdoors. Failure to properly install this water heater outdoors may result in property damage, personal injury, or death. Refer to the installation of the water heater in this Installation and Operation manual for details on the location and installation outdoors. Do not install indoors.

UNPACKING

INSPECT SHIPMENT carefully for any signs of damage.

1. All equipment is carefully manufactured, inspected and packed.
2. Any claims for damage or shortage in shipment must be filed immediately with Bradford White Corporation and noted on the Bill of Lading.

WATER HEATER LOCATION

1. This water heater must be installed outdoors.
2. The water heater must be installed on a wall capable of supporting at least 55 pounds (25 kg). Locate the water heater at a height convenient for servicing and above the reach of small children.
3. Refer to Table 3 for minimum installation clearances.
4. If the water heater is installed in a confined space, such as a closet, ventilation air must be provided to prevent increased room temperature. Excessive ambient temperatures surrounding the water heater may shorten the life of the controls.

REMOVE CARTON

Move water heater to a location near where it will be installed. Carefully slide water heater out from the carton and remove all the contents.

MOUNT WATER HEATER ON THE WALL

This water heater must be installed outdoors. Refer to Table 3 clearances under overhangs, windows, doors, etc. Also, avoid locations where there is heavy water run-off from roofs. Determine the proper height and location for the water heater to be installed. Consider the water and gas connections. Allow enough room for servicing the water heater and maintain the clearances from combustible materials.

The water heater is supported on the wall by means of a top and bottom slotted angle bracket. For convenience, the center hole of the bracket is slotted so that a center screw may be first installed in the wall for hanging the water heater on the wall. Two more screws are then added on the ends of the bracket to secure the water heater. Wall anchors should be used for the bracket holes unless the bracket lines up with a stud. As an alternative, a suitable piece of plywood may be cut to span the wall studs and the brackets fastened to the plywood. Make sure the anchors are rated to support the 55 pound (25 kg) weight of the water heater.

Table 3. Water Heater Clearances.

	to Combustibles	to Non- Combustibles
Top of Water Heater	12 inches (305 mm)	2 inches (51 mm)
Back of Water Heater	0 (zero)	0 (zero)
Front of Water Heater (Panel)	24 inches (610 mm)	0 (zero)
Front of Water Heater (Exhaust)	24 inches (610 mm)	24 inches (610 mm)
Sides of Water Heater	6 inches (152 mm)	1/8 inch (3.2 mm)
Floor/ Ground	12 inches (305 mm)	2 inches (51 mm)

NOTICE

The recommended minimum clearance for servicing is 24 inches (610 mm) in front of the water heater.

State Regulations

NOTICE BEFORE INSTALLATION

Bradford White direct-vent appliance must be installed by a state qualified or licensed contractor. If you are not properly trained, you must not install this unit.

IMPORTANT: In the State of Massachusetts (248CMR 4.00 & 5.00)

For all side wall horizontally vented gas fueled equipment installed in every dwelling, building or structure used in whole or in part for residential purposes, including those owned or operated by the Commonwealth and where the side wall exhaust vent termination is less than seven (7) feet above finished grade in the area of venting, including but not limited to decks and porches, the following requirements must be satisfied:

1. **INSTALLATION OF CARBON MONOXIDE DETECTORS.** At the time of installation of the side wall horizontal vented gas fueled equipment, the installing plumber or gasfitter must observe that a hard wired carbon monoxide detector with an alarm and battery back-up is installed on the floor level where the gas equipment is to be installed. In addition, the installing plumber or gasfitter must observe that a battery operated or hard wired carbon monoxide detector with an alarm is installed on each additional level of the dwelling, building or structure served by side wall horizontal vented gas fueled equipment. It is the responsibility of the property owner to secure the services of qualified licensed professionals for the installation of hard wired carbon monoxide detectors.
 - a. In the event that the side wall horizontally vented gas fueled equipment is installed in a crawl space or an attic, the hard wired carbon monoxide detector with alarm and battery back-up may be installed on the next adjacent floor level.
 - b. In the event that the requirements of this subdivision cannot be met at the time of completion of installation, the owner shall have a period of thirty (30) days to comply with the above requirements; provided, however, that during said thirty (30) day period, a battery operated carbon monoxide detector with an alarm must be installed.
2. **APPROVED CARBON MONOXIDE DETECTORS.** Each carbon monoxide detector as required in accordance with the above provisions shall comply with NFPA 720 and be ANSI/UL 2034 listed and IAS certified.
3. **SIGNAGE.** A metal or plastic identification plate must be permanently mounted to the exterior of the building at a minimum height of eight (8) feet above grade directly in line with the exhaust vent terminal for the horizontally vented gas fueled heating appliance or equipment. The sign must read, in print size no less than one-half (1/2) inch in size, "**GAS VENT DIRECTLY BELOW. KEEP CLEAR OF ALL OBSTRUCTIONS**".
4. **INSPECTION.** The state or local gas inspector of the side wall horizontally vented gas fueled equipment shall not approve the installation unless, upon inspection, the inspector observes carbon monoxide detectors and signage installed in accordance with the provisions of 248 CMR 5308(2)(a)1 through 4.

! WARNING

For all closet installations, follow the minimum clearances to combustibles whether the closet door is combustible or non-combustible.

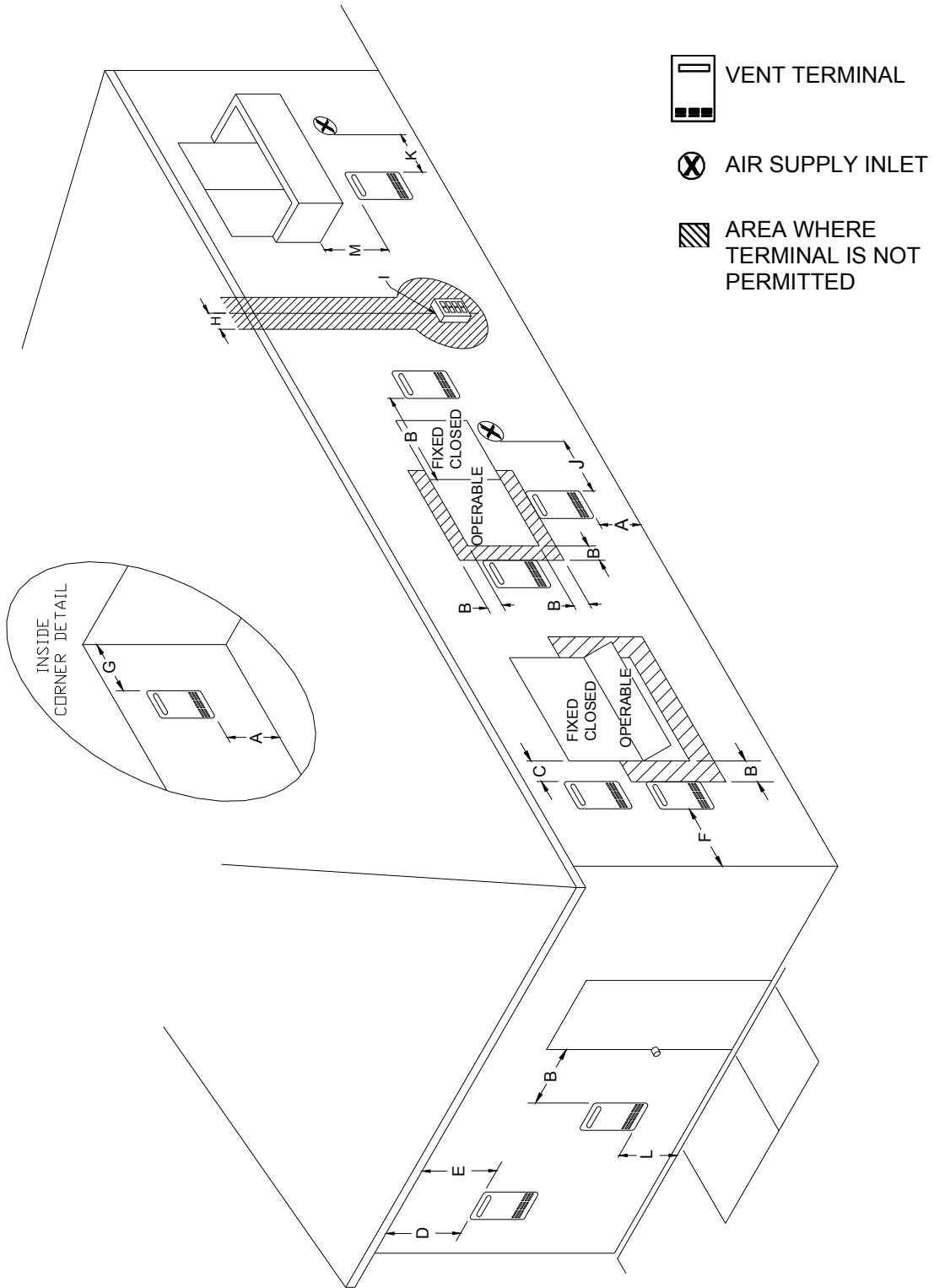

Figure 3. Installation Clearances.

Table 4. Installation Clearances.

Ref	Description	Canadian Installations	US Installations
A	Clearance above grade, veranda, porch, deck, or balcony	12 inches (30 cm)	12 inches (30 cm)
B	Clearance to window or door that may be opened	36 inches (91 cm)	12 inches (30 cm)
C	Clearance to permanently closed window	*	*
D	Vertical clearance to ventilated soffit, located above the terminal within a horizontal distance of 2 feet (61 cm) from the center line of the terminal	*	*
E	Clearance to unventilated soffit	*	*
F	Clearance to outside corner	*	*
G	Clearance to inside corner	*	*
H	Clearance to each side of center line extended above meter/regulator assembly	3 feet (91 cm) within a height 15 feet (4.5 m) above the meter/regulator assembly	*
I	Clearance to service regulator vent outlet	36 inches (91 cm)	*
J	Clearance to non-mechanical air supply inlet to building or the combustion air inlet to any other appliance	36 inches (91 cm)	12 inches (30 cm)
K	Clearance to a mechanical air supply inlet	6 feet (1.83 m)	3 feet (91 cm) above if within 10 feet (3 m) horizontally
L	Clearance above paved sidewalk or paved driveway located on public property	7 feet (2.13 m) ♦	*
M	Clearance under veranda, porch, deck, or balcony	12 inches (30 cm) ▲	*

♦ A vent shall not terminate directly above a sidewalk or paved driveway that is located between two single family dwelling and serves both dwellings.

▲ Permitted only if veranda, porch, deck, or balcony is fully open on a minimum of two sides beneath the floor.

* For clearances not specified in ANSI Z223.1/NFPA 54 or CSA B149.1, clearances are in accordance with local installation codes and the requirements of the gas supplier.

Local codes supersede these clearances.

- Avoid termination locations near a dryer vent.
- Avoid termination locations near commercial cooking exhausts.

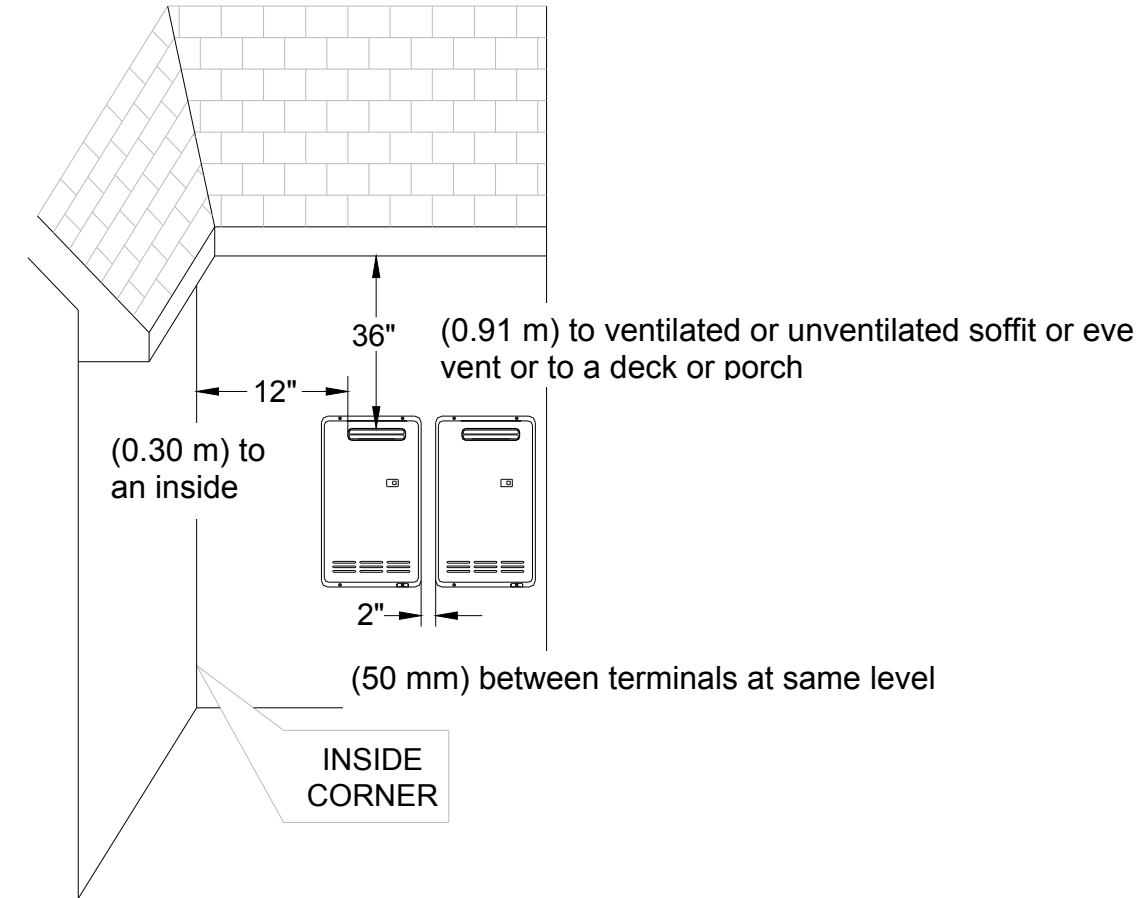
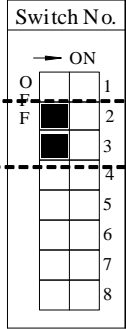
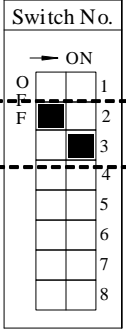
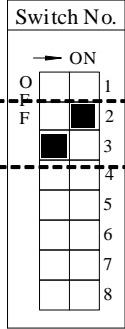
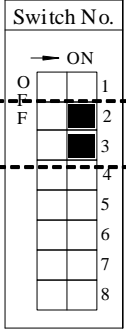

Figure 4. Additional Installation Clearances.

High Altitude Installations

The default setting for the water is 0-2,000 ft (0-610 m) with dip switch numbers 2 and 3 in the OFF position. If this water heater is installed at a higher altitude, it is necessary to modify the dip switch settings according to Table 5.

Table 5. Dip Switch Settings for High Altitude Installations.

	0-2000 ft (0-610 m)	2001-5200 ft (610-1585 m)	5201-7700 ft (1585-2347 m)	7701-10200 ft (2347-3109 m)
Switch No. 2	OFF	OFF	ON	ON
Switch No. 3	OFF	ON	OFF	ON
				

SECTION IV: WATER CONNECTIONS

WARNING

Failure to install and maintain a new, listed pressure relief valve will release the manufacturer from any claim, which might result from excessive temperature and pressures.

Keep clear of the pressure relief valve discharge line outlet. The discharge may be hot enough to cause scald injury. The water is under pressure and may splash.

WARNING

DO NOT reverse the inlet and outlet (cold and hot water) connections on the water heater. This may cause a hazardous operating condition or the water heater may be inoperable

WATER QUALITY

The EverHot® water heater must have the water quality within the following limits for long life and reliable operation. The water supply should be tested to make sure the quality is within the specified limits. If there is a problem with the water quality, contact your local water conditioning company for equipment to condition the water supply to this appliance.

NOTICE

Operating this water heater with water conditions outside the specified limits will void the warranty.

Table 6. Maximum Levels for Water Quality.

Description	pH	TDS (Total Dissolved Solids)	Total Hardness	Aluminum	Chlorides	Copper	Iron	Manganese	Zinc
Maximum Levels	6.5 to 8.5	Up to 500 ppm	Up to 11.7 grains	Up to 0.2 ppm	Up to 250 ppm	Up to 1.0 ppm	Up to 0.3 ppm	Up to 0.05 ppm	Up to 5 ppm

Note: 1 ppm = 1 mg/L

NOTICE

If the EverHot water heater is operated under hard water conditions without a water conditioner, the diagnostic code "LC" may flash on the water heater's control. This code means the heat exchanger coil is beginning to accumulate mineral deposits and MUST be flushed (see Section VIII, "Flushing Procedure for Mineral Scale Removal..."). Contact your installer for a qualified service technician to flush the heat exchanger. A water conditioner may be needed to prevent this condition from re-occurring.

CAUTION

Failure to flush the water heater when "LC" is flashing will cause damage to the heat exchanger. Damage caused by mineral scale build up is not covered by the water heater warranty.

INSTRUCTIONS FOR CONNECTIONS

1. BEFORE PROCEEDING WITH THE INSTALLATION, CLOSE THE MAIN WATER SUPPLY VALVE. After shutting off the main water supply, open a faucet to relieve the water line pressure to prevent any water from leaking out of the pipes while making the water connections to the water heater. The COLD water inlet and HOT water outlet are identified on the bottom casing of the water heater. Make the proper plumbing connections between the water heater and the plumbing system to the house. All soldering materials and piping must be compatible with

potable water. Unions should be installed on both the hot and cold water lines for future servicing and disconnection of the water heater. Install a shut-off valve in the cold water supply line.

2. In order to service the water heater in the event the heat exchanger needs to be flushed of mineral deposits, tee fittings with shut-off valves and service connections to hoses should be installed. Also, install a shut-off valve to the hot water supply to isolate the service tee fittings. A plumbing installation kit, which includes these fittings and a pressure relief valve, is available from your supplier. Refer to the piping diagrams in Section IV, "Water Connections".
3. Install a pressure relief valve on a tee connection from the hot water outlet piping from the water heater. Refer to the piping diagrams (Figure 6 and Figure 7) and pressure relief valve warning in Section IV, "Water Connections."
4. In cold climates, where piping can freeze during an extended power failure, drain solenoid valves should be installed on the cold and hot water supply lines to allow water to drain from the water heater when power is interrupted. Refer to the piping diagram (Figure 8) "Recommended Piping for Power Failure Freeze Protection" in Section IV, and contact your Bradford White dealer if assistance is needed.
5. If this water heater is installed in a closed water supply system, such as the one having a back-flow preventer in the cold water supply, provisions must be made to control thermal expansion. DO NOT operate this water heater in a closed system without provisions for controlling thermal expansion. Warranties do not cover damages from thermal expansions, such as pressure bulges and/or deformities. Your water supplier or local plumbing inspector should be contacted on how to control this situation.
6. Purge the cold water line prior to connecting to the water heater to remove debris. Debris will clog the mesh strainer of the inlet filter. The inlet strainer prevents debris from damaging the flow sensor or clogging the coil. It may need to be cleaned periodically and should be cleaned after the initial operation. DO NOT operate the water heater without the filter in place. In areas where sediment may be periodically present in the water supply, a Y-type strainer (#20 mesh) or cartridge filter should be installed on the cold water inlet to the water heater to prevent the water heater fine mesh strainer from getting plugged and restricting water flow.
7. After installation of the water lines, open the main water supply valve and fill the water heater. While the water heater is filling, open several hot water faucets to allow air to escape from the water system. When a steady stream of water flows through the faucets, close them and check all water connections for possible leaks.
8. This water heater may also be connected to a circulating pump or storage tank for increased flow capacity during high demand periods.
9. Commercial installations may require more than one water heater piped together in a manifold to supply enough capacity for high temperature and high water flow applications. Special controls are available from your Bradford White supplier for operating more than one water heater together. These controls stage the operation of the water heaters for the flow rates and control the amount of flow through each water heater. Order p/n MSA-2M for the electronic manifold control for the first and second water heater and p/n MSA-2S for the wiring harness for each additional water heater to be controlled. A maximum of (5) water heaters can be connected together. Alternatively, to connect only (2) water heaters, an EZConnect™ harness, p/n REU-EZC-1US, can be used. Instructions are included with these parts.

NOTICE

Take care when using pipe dope or thread sealing tape to avoid clogging the inlet screen and water flow sensor. Wipe off excess pipe dope from threads before connecting to the water heater.

Commercial dishwashers will require either more than one water heater, or a storage tank to supply a sufficient volume of hot water.

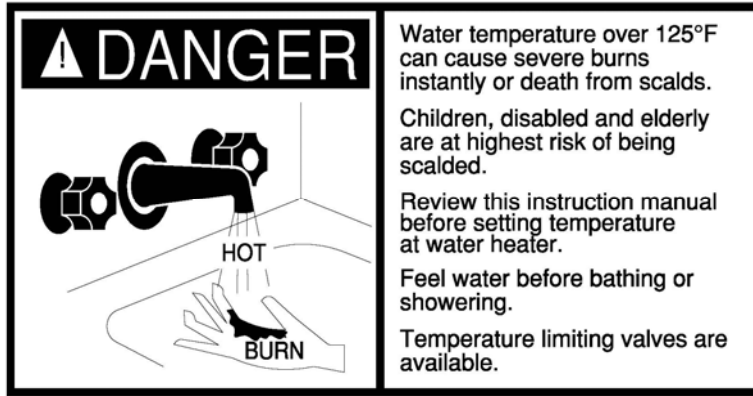
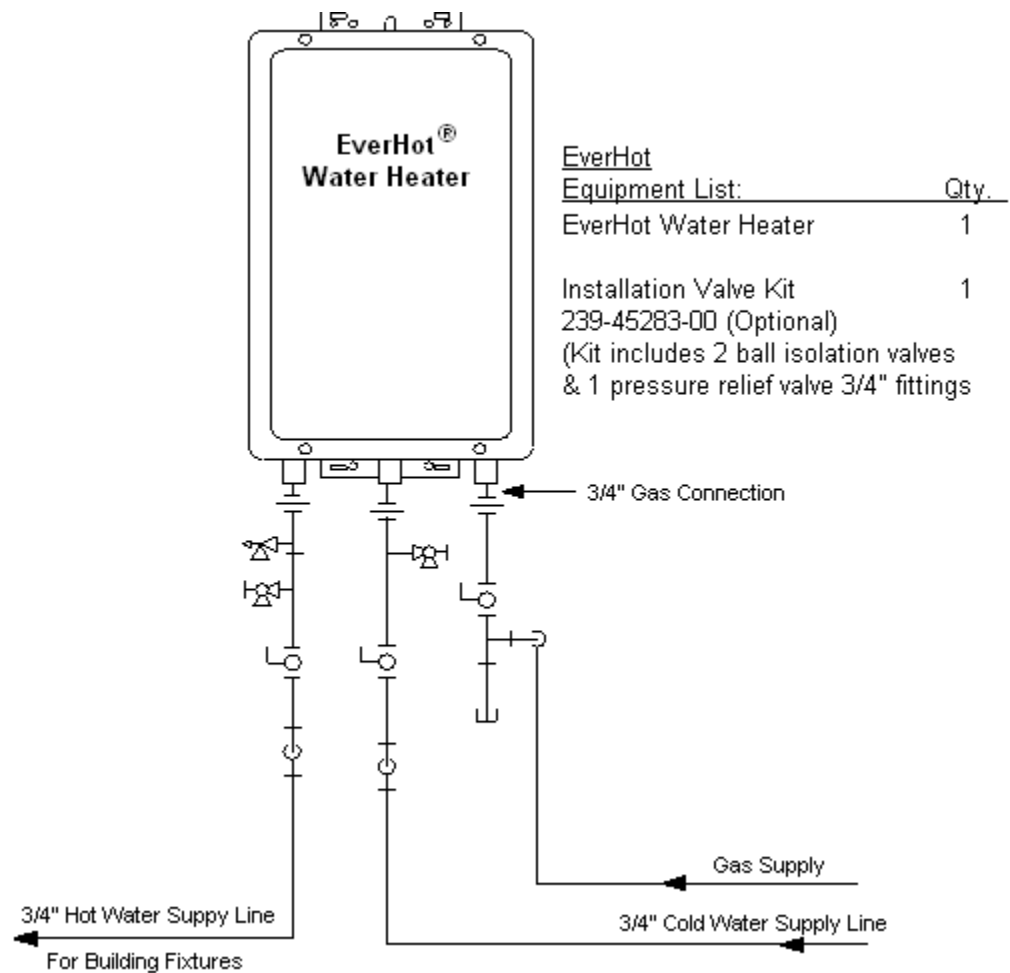

Figure 5. Scald Warning.

Table 7. Approximate scald time/temperatures.

APPROXIMATE TIME/TEMPERATURE RELATIONSHIPS IN SCALDS	
120°F (49°C)	More than 5 minutes
125°F (52°C)	1½ to 2 minutes
130°F (54°C)	About 30 seconds
135°F (57°C)	About 10 seconds
140°F (60°C)	Less than 5 seconds
145°F (63°C)	Less than 3 seconds
150°F (66°C)	About 1½ seconds
155°F (68°C)	About 1 second



KEY



Figure 6. Recommended Piping for a Basic Installation.

NOTE:

For residential and commercial applications, this piping arrangement maintains full warranty.

For this application:

Pump should be controlled by an Aquastat, Timer or Combination Aquastat and Timer.

Pump to be sized to maintain circulation loop temperature.

The pump should be sized to overcome the pressure loss through the tank water heater, and supply and return plumbing.

Pump to be suitable for potable water applications.

IMPORTANT: Connect the building return line to the hot water supply line as close as possible to the EverHot Water Heater.

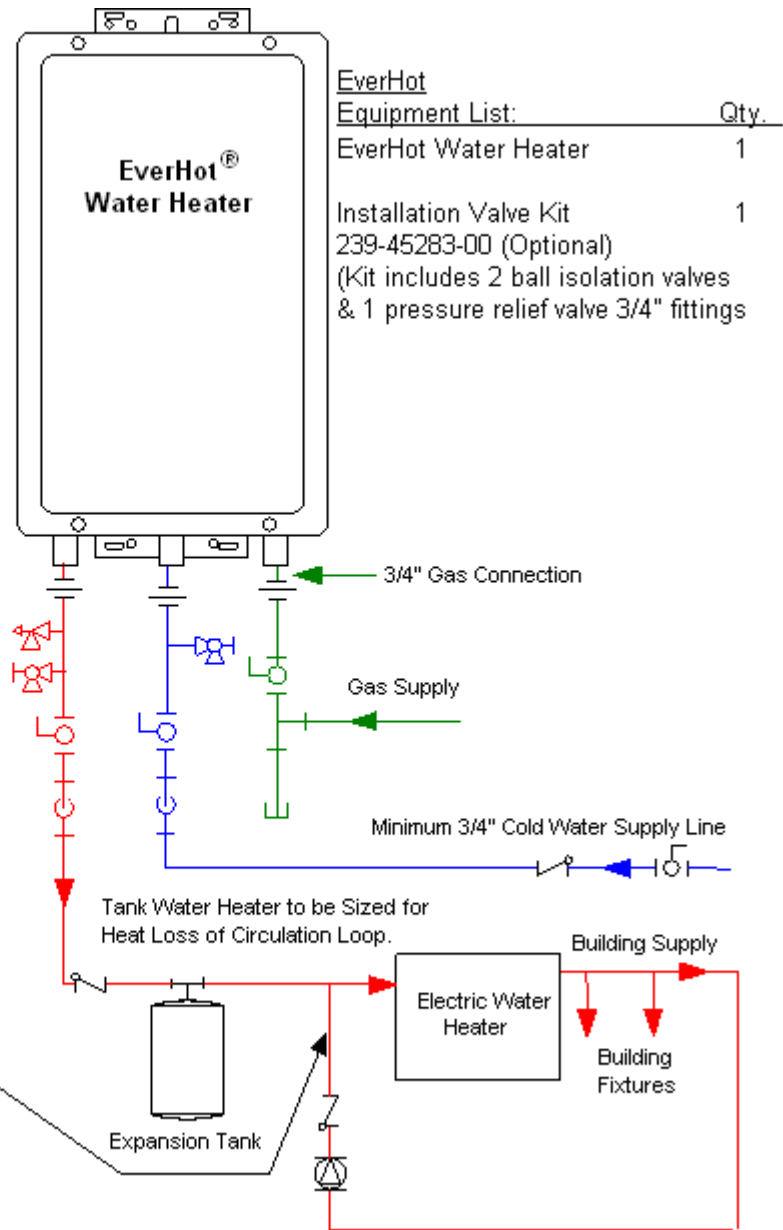

KEY

	3/4" Ball Valve		Pressure Regulator
	3/4" Union		Circulating Pump
	Check Valve		Boiler Drain Valve
	Pressure Relief Valve		Solenoid Valve

Figure 7. Recommended Piping for a Circulation Systems.

Recommended Piping for Power Failure Freeze Protection

As long as electrical power and gas are supplied to the EverHot® water heater, freeze protection is provided to the heat exchanger and piping inside the water heater with ambient temperatures as cold as -30°F (-34°C), when protected from direct wind exposure. In the event of a power failure with ambient temperatures below freezing, the water heater must be drained of all water to prevent freeze damage. The water heater may be drained manually, or automatically, through the installation of the optional solenoid valves, as shown in the following illustration. The drain solenoids are recommended for very cold climates to prevent water heater freeze damage where power failures from ice and windstorms occur.

The electrical connections for the two solenoids must be tied to the 120 volt main power supply (black and white wires). When the electrical power to the water heater fails, the 3/4" solenoid on the cold water inlet pipe closes, stopping water flow into the water heater. The drain solenoid opens, allowing the water heater and connected piping to drain. Make sure the piping from the drain solenoid is run to a suitable drain or outside the building to prevent water damage.

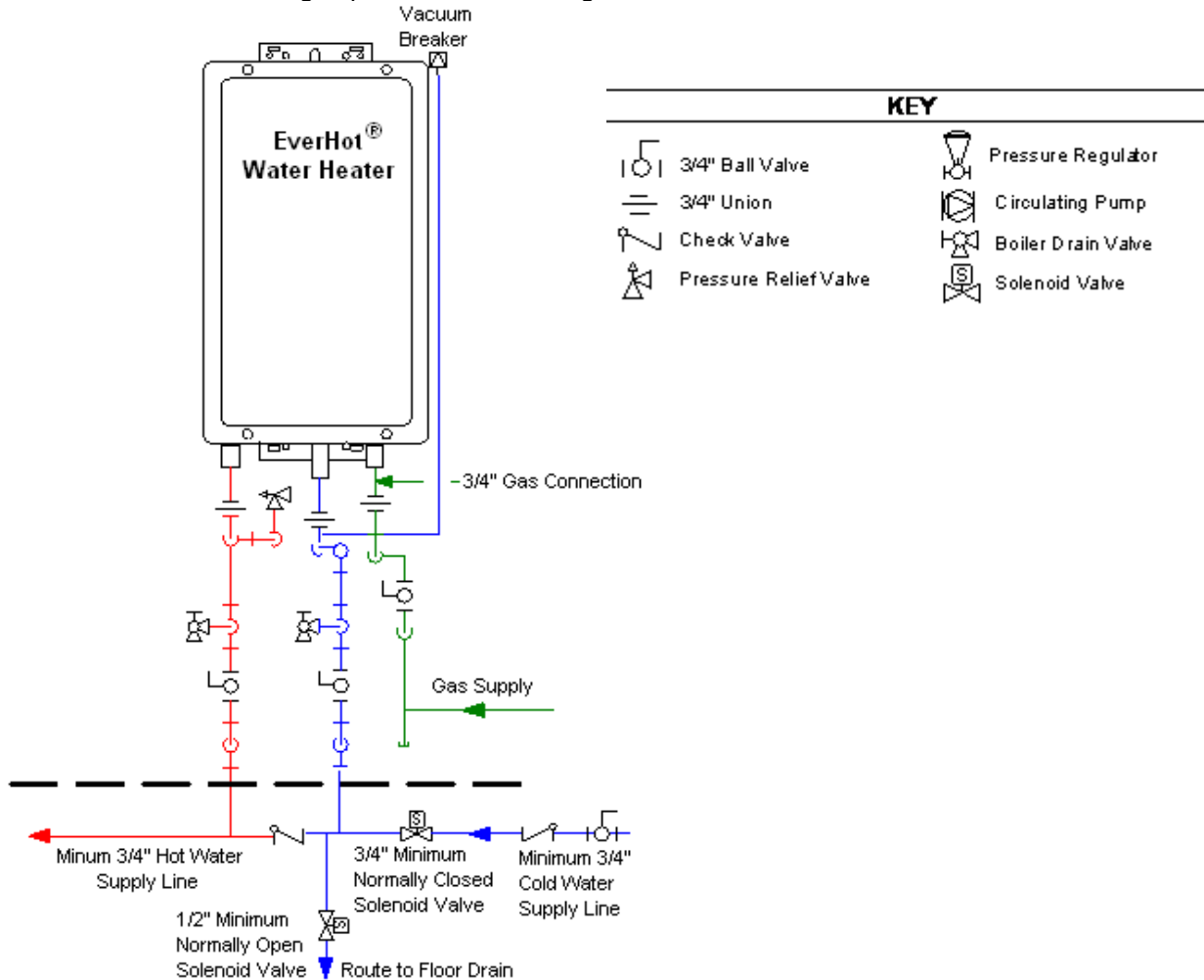

Figure 8. Recommended Piping for Freeze Protection.

! CAUTION

Heat trace all water pipe and fittings located outside the home (attic, crawl space) or building structure. All pipe and fittings shown below dashed line (see Figure 8) should be located inside home or building structure. The vacuum breaker line should be located inside the building structure.

All piping located outside the building must be insulated and wrapped with heat tape to prevent freezing.

PRESSURE RELIEF VALVE



Keep clear of the pressure relief valve discharge line outlet. The discharge may be hot enough to cause scald injury. The water is under pressure and may splash.

For protection against excessive pressure, install pressure protective equipment required by local codes, but not less than a pressure relief valve certified by a nationally recognized testing laboratory that maintains periodic inspection of production of listed equipment or materials as meeting the requirements of the Standard for Relief Valves and Automatic Gas Shutoff Devices for Hot Water Supply Systems, ANSI Z21.22 and the Standard CAN1-4.4 Temperature, Pressure, Temperature and Pressure Relief Valves and Vacuum Relief Valves. The pressure relief valve must be marked with a maximum set pressure not to exceed the maximum working pressure of the water heater. The pressure relief valve rating must not be less than the hourly rating of the water heater.

Install the pressure relief valve into a tee connection from the hot water outlet of the water heater.

Note: Some models may already be equipped or supplied with an installed pressure relief valve. Verify that the pressure relief valve complies with local codes. If the pressure relief valve does not comply with local codes, replace it with one that does. Follow the installation instructions in the following paragraph.

Install a discharge line so that water discharged from the pressure relief valve will exit within six (6) inches (15.2 cm) above, or any distance below the structural floor and cannot contact any live electrical part. The discharge line is to be installed to allow for complete drainage of both the combination temperature and pressure relief valve and the discharge line. The discharge opening must not be subjected to blockage or freezing. DO NOT thread, plug or cap the discharge line. It is recommended that a minimum clearance of four (4) inches (10.2 cm) be provided on the side of the water heater for servicing and maintenance of the pressure relief valve.

DO NOT place a valve between the pressure relief valve and the hot water outlet!

Combination Water and Space Heating Applications – Commercial Use Water Heaters Only

Commercial use water heaters may be used for space heating or combination space heating/potable water heating applications, provided the following requirements and recommended piping diagrams are carefully followed.

WARNING

The following instructions must be carefully followed to assure safe and reliable operation of the water heater. All piping components connected to this water heater must be suitable for use with potable water. In Massachusetts, space heating piping length must not exceed 50 feet. Toxic chemicals, such as those used for boiler treatment, must not be introduced into potable water used for space heating. This water heater must not be connected to an existing heating system or component(s) previously used with a non-potable water heating appliance. When the system requires water for space heating at temperatures higher than required for other means, an ASSE approved mixing valve must be installed to temper the water for those uses in order to reduce the scald hazard potential.

1. Only commercial use water heaters may be used for combination water heating/space heating applications. Residential use water heaters will not be covered under warranty for water heating/space heating applications.
2. The temperature setting of the water heater thermostat must not exceed 160°F.
3. In combination space heating/potable water heating applications that require higher water temperatures than normally used for potable water uses, an ASSE approved thermostatic mixing valve must be installed to temper the water for those uses in order to reduce the scald hazard potential.
4. In order to assure adequate flow through the water heater, follow the recommended piping diagram and circulator specifications (see Figure 9).
5. An expansion tank will be required in all space heating applications.
6. A Y-type mesh strainer (#20 mesh screen) should be installed on the cold water inlet of the water heater to prevent clogging of the fine mesh screen on the water heater cold water inlet connection.
7. A water softener must be used if the water supply has a tested hardness level above 10 grains of hardness.
8. All piping must be ¾" copper or larger.
9. All components must be suitable for use with potable water.
10. The water heater should be located as close as practical to the space heating heat exchanger.
11. A check valve should be located after the circulator(s) to prevent backflow during potable water demands.
12. A heat exchanger may be required to separate the potable water from the space heating circuit in certain applications.

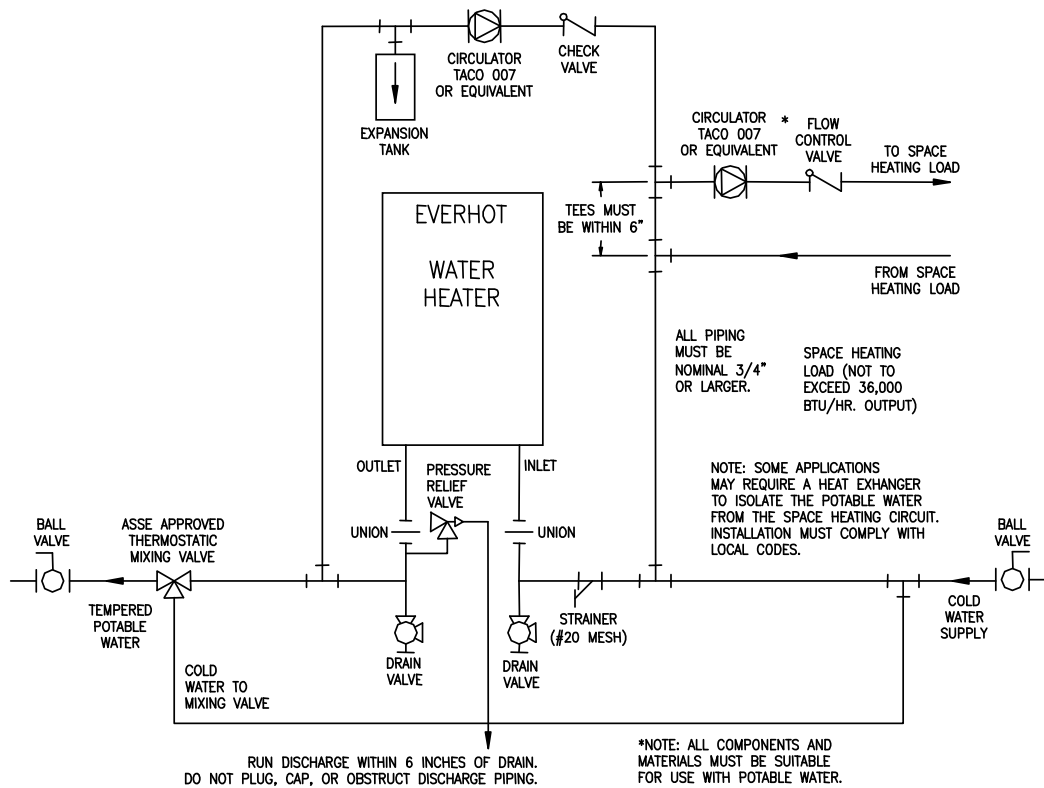

Note: in Massachusetts, the following must be done:

- Tempered potable water must meet temperatures in 248 CMR.
- All water piping must be insulated in accordance with 780 CMR (Massachusetts energy code).
- 50 feet maximum distance from water heater to space heating load (developed length).
- Piping loop between water heater and heating load must be in compliance with 248 CMR.
- All circulators must use an electronically controlled timer that activates every 6 hours for 60 seconds.

Figure 9. Recommended Piping for Combination Water and Space Heating Applications.

SECTION V: GAS CONNECTIONS

WARNING

Connect this water heater only to the type of gas as shown on the rating plate. Use clean black iron pipe or equivalent material approved by local codes and ordinances. Dirt and scale from the pipe can enter the gas valve and cause it to malfunction. The inlet gas line must have at least a 3 in. (7.62 cm) drip leg (sediment trap) installed as close to the water heater's gas valve as possible. A ground joint union must be installed in the gas supply line, as close to the water heater as possible, to permit servicing of the water heater. Compounds used on the threaded joints of the gas piping must be resistant to the action of liquefied petroleum gases/propane gas. DO NOT apply pipe dope to the gas valve inlet, and make certain that no pipe dope has become lodged in the inlet screen of the gas valve. Extreme care must be taken to ensure no pipe dope enters the gas valve and to avoid excessive torque when tightening the gas supply line to the gas valve. Excessive torque may result in cracking of the gas valve housing. The suggested maximum torque is 31.5 ft-lbs. (4.4 kg-m). The manufacturer of this water heater will not be liable for any damage or injury caused as a result of a cracked gas inlet as a result of excessive torque.

This water heater and its gas connection must be leak tested before placing the water heater in operation. Check for gas leaks with a soap and water solution and a brush or a commercial leak detector fluid. NEVER USE A MATCH OR OPEN FLAME FOR TESTING!

The water heater is not intended for operation at higher than 10.5 inches water column, for natural gas, 13.5 inches water column for L.P. supply gas pressure. Higher gas supply pressures require supplemental reducing service regulation. Exposure to higher gas supply pressure may cause damage to the gas controls, which could result in fire or explosion. If overpressure has occurred, such as through improper testing of gas lines or emergency malfunction of the supply system, the gas valve must be checked for safe operation. Make sure that the outside vents on the supply regulators and the safety vent valves are protected against blockage. These are parts of the gas supply system, not the water heater.

WARNING

Conversion of this unit from natural gas to L.P. or L.P. to natural gas CANNOT be done in the field. If the gas supply does not match the type shown on the water heater rating plate, then contact your supplier for the proper water heater for the building gas supply.

CAUTION

The water heater and individual shut-off valve must be disconnected from the gas supply piping system during any pressure testing of the system at test pressures in excess of ½ psi (3.5 kPa). The water heater must be isolated from the gas supply piping system by closing its manual shutoff valve during any pressure testing of the gas supply system at test pressures equal to or less than ½ psi (3.5 kPa). The supply line must be capped when not connected to the water heater.

If copper supply lines are used, they must be internally tinned and certified for gas service.

The gas supply lines must meet all requirements of the National Fuel Gas Code ANSI Z223.1-Latest Edition, or in Canada Natural Gas Installation Code CAN/CGA B149.1-Latest Edition or Propane Installation Code CAN/CGA B149.2-Latest Edition. The gas supply line may need to be larger for EverHot® water heaters than a storage water heater in the case of a replacement installation. Refer to the piping capacity tables at the end of Section V, "Gas Connections" and in the codes referenced above.

A 3 in. (7.6 cm) drip leg (sediment trap) is required ahead of the gas inlet connection to the water heater. Install a manual gas shut-off valve before the gas inlet connection to the water heater before connecting to the gas line. A union should be installed before the water heater gas connection for disconnection for servicing.

Check the type of gas and the gas inlet pressure before connecting the EverHot® water heater to the gas supply. If the gas supply type does not match the type shown on the water heater rating plate, then DO NOT connect the water heater. Contact your Bradford White supplier for the correct water heater.

GAS METER SIZE – NATURAL GAS ONLY

Be sure that the gas meter has sufficient capacity to supply the full rated gas input of the water heater, as well as the requirements of all other gas fired equipment supplied by the meter. If the gas meter is too small, ask the gas company to install a larger meter having adequate capacity.

GAS PRESSURE REGULATION

Minimum and maximum gas supply pressures are listed below: The minimum gas pressure specified below is required for the full input rating specified on the water heater rating plate.

Natural Gas:	Minimum: 5.0 in. w.c.	L.P. Gas:	Minimum: 8.0 in. w.c.
	Maximum: 10.5 in. w.c.		Maximum: 13.5 in. w.c.

Before placing the WATER heater in operation, check for gas leakage. Use soap and water solution or other material acceptable for the purpose of locating gas leaks.



WARNING

DO NOT use matches, candles, flame, or other sources of ignition for this purpose.

Table 8. Maximum Capacity of Schedule 40 Pipe in CFH for Gas Pressures of ½ psig or Less.

Length		0.5 in. W.C. Pressure Drop		
(feet)	(meters)	3/4	1	1 1/4
10	3.0	360	680	1,400
20	6.1	250	465	950
30	9.1	200	375	770
40	12.2	170	320	660
50	15.2	151	285	580
60	18.3	138	260	530
70	21.3	125	240	490
80	24.4	118	220	460
90	27.4	110	205	430
100	30.5	103	195	400

Table 9. Specific Gravity Correction Factors.

Specific Gravity	Correction Factor	Specific Gravity	Correction Factor
0.50	1.10	1.30	1.07
0.55	1.04	1.40	1.04
0.60	1.00	1.50	1.00
0.65	0.96	1.60	0.97
0.70	0.93	1.70	0.94
0.75	0.90		
0.80	0.87		

Note: After determining the length of pipe required, select the pipe size that will supply the CFH (cubic feet per hour) of gas required for the input rating of the gas appliances on the line. To determine the CFH required for the gas appliances on the line, use the formula, shown below. The heating value of the gas used may be obtained from a local gas utility.

$$CFH = \frac{\text{Gas Input of Appliance(s) on the Line (Btu/hr)}}{\text{Heating Value of Gas (Btu/Cu. ft)}}$$

SECTION VI: ELECTRICAL CONNECTIONS

 **WARNING**

Turn off or disconnect the electrical power supply to the water heater before servicing. Label all wires prior to disconnection when servicing controls. Wiring errors can cause improper and dangerous operation. Verify proper operation after servicing.

All electrical wiring must be installed and grounded in accordance with local codes, or in the absence of local codes, the National Electrical Code, ANSI/NFPA 70 and/or CSA C22.2 Electrical Code.

The water heater must be wired to a 120 VAC, 60 Hz, 15A power supply. The water heater should be connected to a GFI outlet and wired on a separate circuit and breaker. A strain relief will be required for the line cord. Do not plug the line cord into a receptacle that can have the power supply interrupted by a switch that is used to control lights or another appliance.

If wiring in conduit is required, install an electrical conduit connector. A disconnect switch should be provided near the water heater for servicing. Connect the wires exactly as shown in the wiring diagram of this manual and on the inside cover panel. The black wire is the hot leg; the white wire is neutral. A green screw is provided in the junction box for the green wire ground connection.

 **CAUTION**

Do not energize the electric circuit before the water heater tank is filled with water.

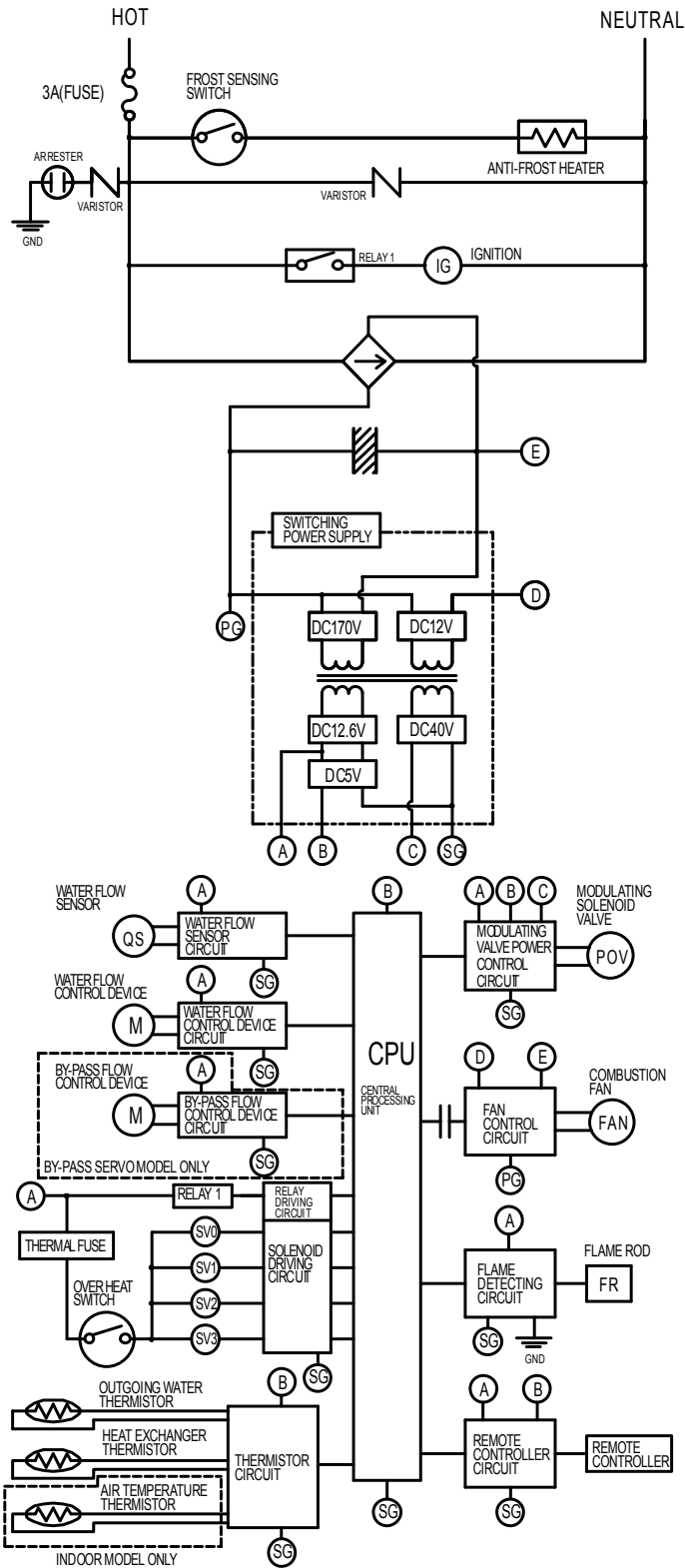

Figure 10. Ladder Diagram.

! WARNING

DO NOT adjust any dipswitch settings on PC board unless instructed to do so.

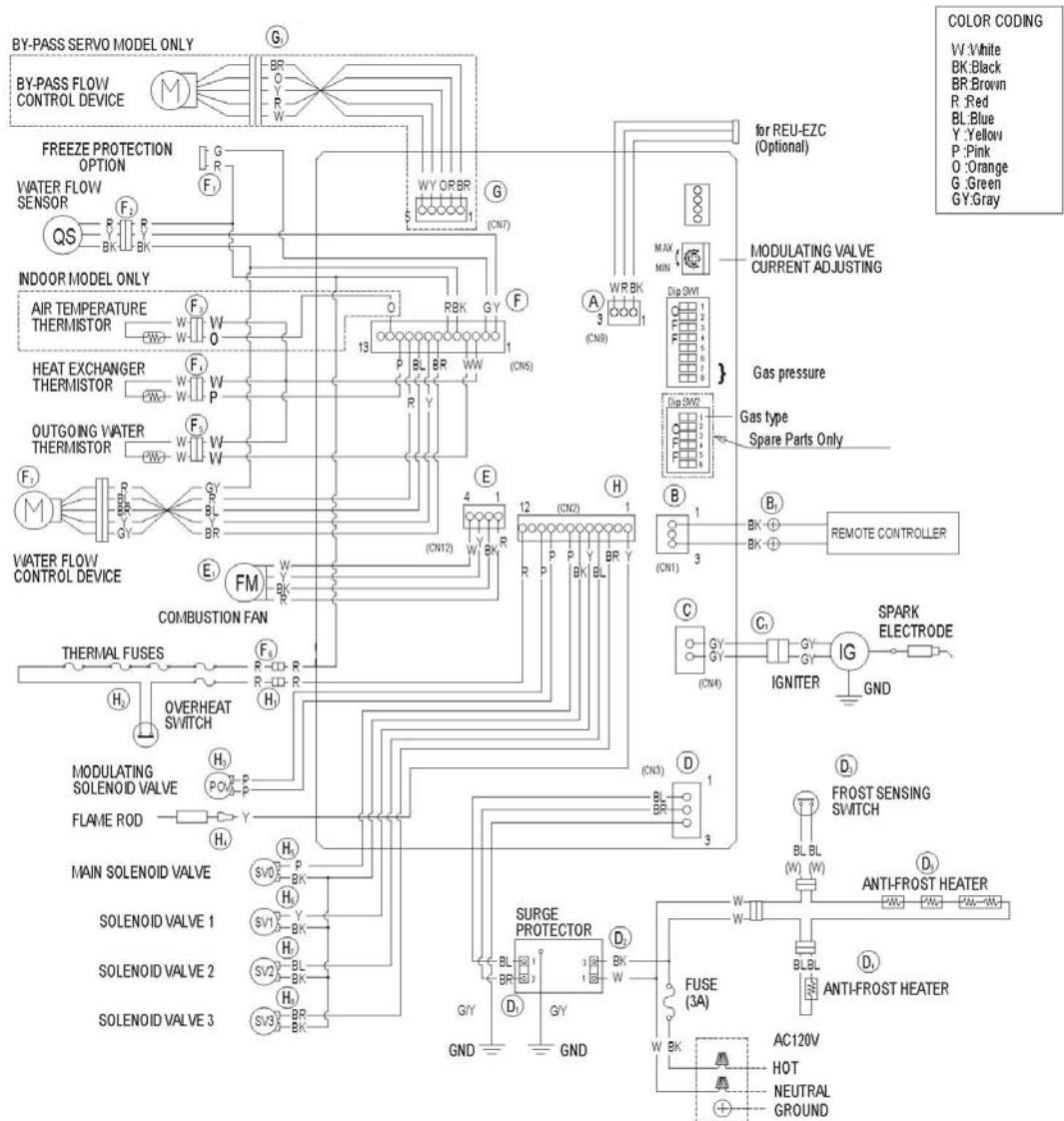

Figure 11. Wiring Diagram for TG-150E-N(X), TG-180E-N(X), and TG-199E-N(X) Models.

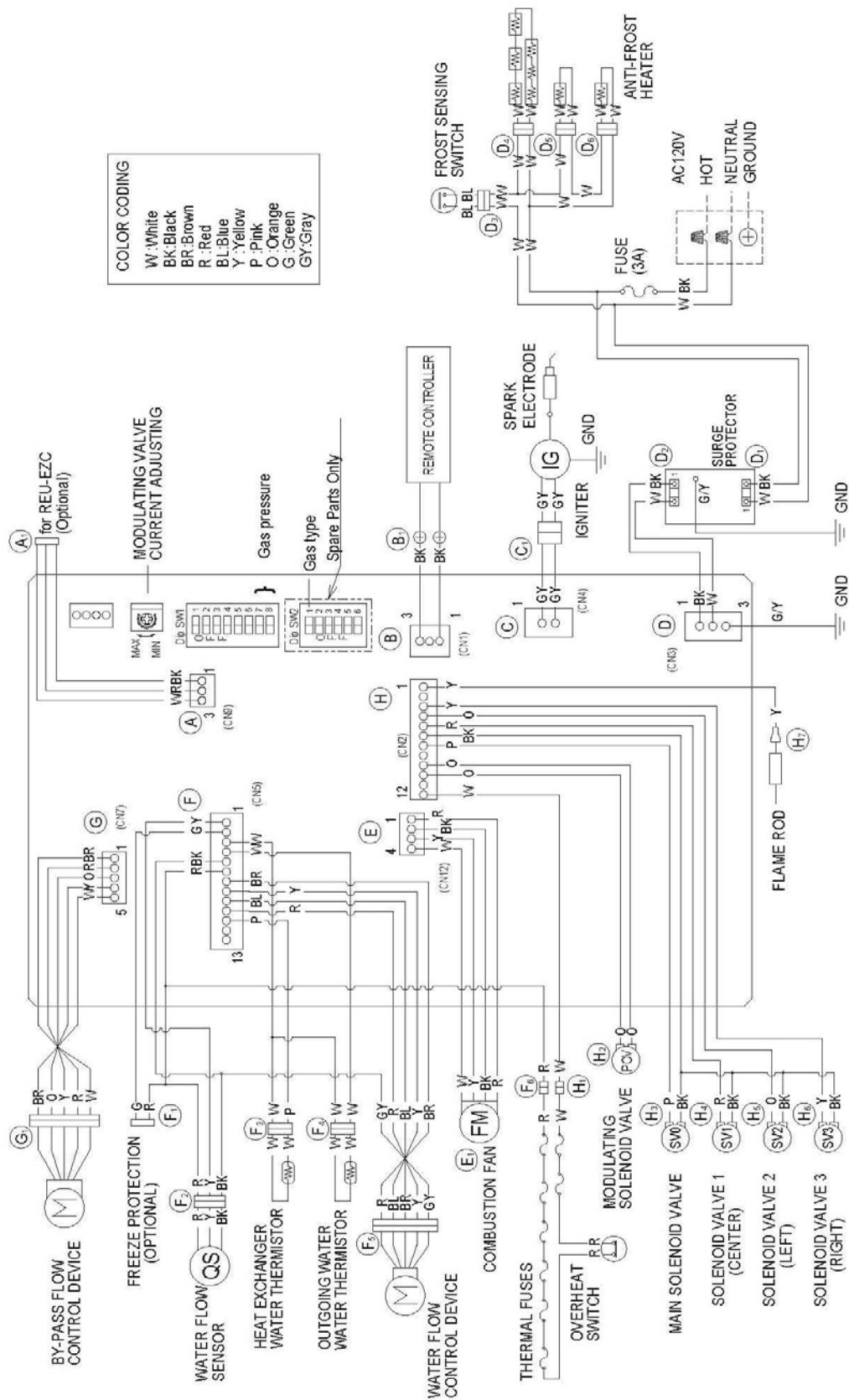

Figure 12. Wiring Diagram for TG-237E-N(X) and TG-237E-N(X)A Models.

TEMPERATURE CONTROLS

The included temperature control allows the end user to set the hot water supply temperature and will display certain diagnostic codes of the water heater if there is a malfunction. All models have the option of up to four controllers that can be used to conveniently control water temperatures for bath and shower fixtures.

The main control is to be at a convenient location inside the installation home or building. The adjustment range is 98-120°F. Additional remote controls can be purchased, p/n 239-47806-00, and these have the same available temperature range as the main control. If an optional commercial control, p/n 239-47805-00, is purchased, the allowable temperature can be up to 185°F on some models (TG-199E and TG-237E only). The other models can get an allowable temperature up to 160°F. If a commercial control is used, this reduces the warranty period of the water heater. Also, if a commercial control is used with a water heater, all of the remaining controls connected to the water heater can achieve the maximum temperature that the commercial control allows. See Table 10 for more details.

Table 10. Available Temperature Settings for TG Models.

TG-150E-N(X) TG-180E-N(X)	96	98	100	102	104	106	108	110	115	120	130*	140*	150**	160**		
TG-199E-N(X)	96	98	100	102	104	106	108	110	115	120	130*	140*	150**	160**	170**	180**
Temp (°C)	36	37	38	39	40	41	42	43	46	49	54	60	66	71	77	82
TG-237E-N(X) TG-237E-N(X)A	98	100	102	104	106	108	110	115	120	125*	130*	135*	140*	150**	160**	185**
Temp (°C)	37	38	39	40	41	42	43	46	49	52	54	57	60	66	71	85

*** Re-setting the Maximum Temperature**

For all models except TG-237E-N(X), TG-237E-N(X)A: These units have a default maximum temperature of 120° F (49° C) and an option to increase the maximum temperature to 140 °F (60 °C). Temperature settings from 125-140 °F (52-60 °C) are available by setting dip switch 6 to ON in the SW1 bank of 8 dip switches.

****239-47805-00, Commercial Control**

These settings require the 239-47805-00 controller. When the 239-47805-00 controller is connected, these higher temperatures are available on all controller models in the system. Use of a 239-47805-00 controller in a residential dwelling will reduce the warranty coverage to that of a commercial warranty application.

DANGER

Hotter water increases the risk of scald injury. Scalding may occur within 5 seconds at a temperature setting of 140°F (60°C). To protect against hot water injury, install a mixing valve in the water system. This valve will reduce point of discharge temperature by mixing cold and hot water in branch water lines. A licensed plumbing professional or local plumbing authority should be consulted.

CAUTION

This water heater, when set at a lower temperature setting is not capable of producing hot water of sufficient temperature for sanitizing purposes. Always check water temperature by hand before entering the shower or bath. The temperature may have been changed. Test the temperature of the water with your hand or elbow before placing a child in the bath or shower. Do not leave a child or an infirm person in the bath unsupervised.

WARNING

Do not adjust this water heater in any residential application above 120°F. If this water heater is used in a commercial application where temperatures in excess of 120°F are required, use an ASSE approved mixing device.

WARNING

This water heater is equipped with an energy cut out device to prevent overheating. Should overheating occur or the gas supply fails to shut off, turn off the manual gas control valve to the water heater, and call a qualified service agency.

NOTICE

The lower the temperature setting, the greater the energy efficiency to heat the water. Lower water temperatures also extend the heat exchanger life. Remember, no water heating system will provide exact temperatures at all times. Allow a few days of operation at this setting to determine the correct temperature setting consistent with the requirements for the installation.

When multiple controls are used, depressing the Priority Button will override the main control and display the setpoint of the remote control in use. Both the remote controls and the main control will display diagnostic codes in the event the water heater needs service.

NOTICE

No more than four temperature controls may be connected to the EverHot[®] water heater.

NOTICE

The default temperature setting that will appear when the water heater is first connected to the electrical supply is 104°F. In the event of a power interruption, the unit will retain its set temperature for up to 6 hours. If the power is interrupted for more than 6 hours, the unit will revert back to a temperature of 104°F.

Before installing optional remote controls, determine the most convenient location(s). When deciding on the best location for the remote controls, please consider the following items:

1. Place the controls out of reach of small children.
2. Avoid locations where the control(s) will become hot, such as over a radiator, register, or other heat sources.
3. Avoid direct sunlight. The digital readout can be difficult to read in direct sunlight.
4. Avoid areas where the remote can be splashed with cooking water, oil, or sauce.
5. The remote control operates with low voltage.

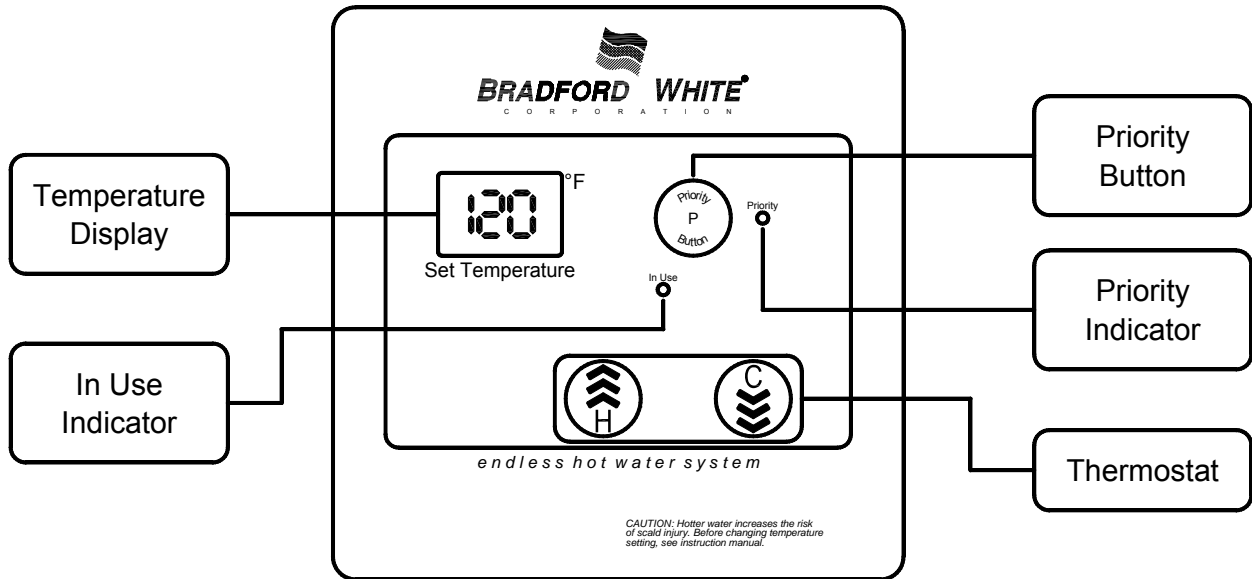

Figure 13. Remote Control and the Description of Functions on All Controls.

Residential Control, p/n 239-47806-00
 Commercial Control, p/n 239-47805-00

Installation of Control(s)

1. The controls may be wired in parallel only.
2. Mark the holes on the wall using the control mounting plate and drill two mounting holes using a 3/32" (2.4 mm) drill bit and a clearance hole for the cable using a 1/4" (6.4 mm) drill bit.

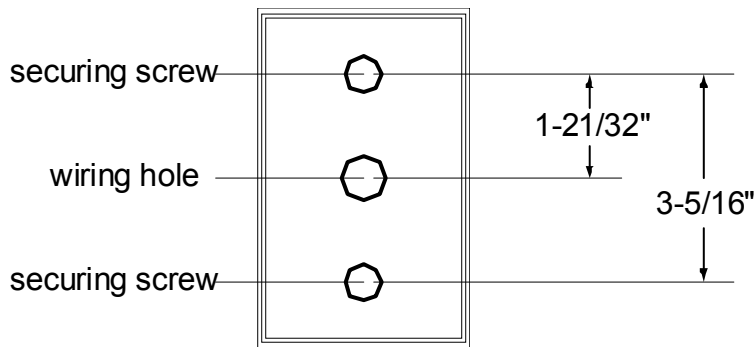

Figure 14. Outline of Remote Control's Mounting Plate.

3. Run the cable from the control to the water heater or another control, which ever is closer or more convenient.
4. Remove the face plate from the control by inserting a screwdriver in the slot and twisting open.
5. Connect the cable to the terminal screws of the control.
6. Mount the control to the wall using the holes drilled and with the screws supplied. Note: Plastic wall anchors may be required if the control is not located over a stud when mounting on wallboard.

Note: If the cable cannot be run inside the wall cavity, then the plastic knockout should be removed from the top or bottom of the control to allow flush mounting with the wall.

7. Disconnect the power from the water heater and remove the front cover.

8. Remove the plastic cover from the PCB and electrical connections.
9. Thread the cable through the access hole at the base of the water heater and connect the wires to the control terminals on the right hand side of the PCB.

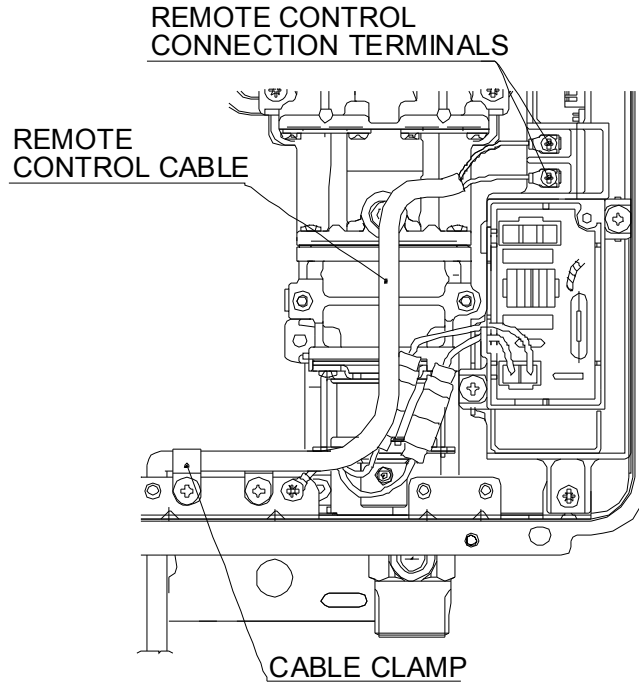

Figure 15. Illustration Showing Where to Connect Remote Control Harness.

10. Secure the control cable using the clamp provided in the control compartment.
11. Replace the plastic cover over the PCB terminals and then replace the front control panel of the water heater.

! WARNING

Do not attempt to connect the controls with the power on to the water heater. There is 120 volt terminals and wiring next to the remote control connections inside the unit. All servicing and wiring must be performed by a qualified installer.

! WARNING

When the water heater or remotely located remote control is used in public use applications, it shall be installed in a location where it cannot be adjusted by the public (i.e. a maintenance room or manager's office). Unauthorized adjustments may result in scalding conditions.

INITIAL OPERATION AND TESTING OF CONTROLS (INSTALLER ONLY)

1. Turn on power to the water heater and fully open a hot water tap.
2. Check the operation of the water heater. Check the operation of the remote temperature control(s). Check the operation of the power failure protection system (drain solenoids).
3. Explain the proper operation of the new Bradford White EverHot® water heater to the end user.

Troubleshooting – Electrical

There are a number of (live) tests that are required when fault finding this product. Extreme care should be used at all times to avoid contact with energized components inside the water heater. Only trained and qualified service technicians should attempt to repair this product. Before checking for resistance readings, disconnect the power source to the unit and isolate the item from the circuit (unplug it).

Table 11. (SV1, SV2, SV3, and POV) Gas Valve and Modulating Solenoids (Set Meter Above 2k).

Wire Color	Voltage	Resistance	Connector No.	Pin Nos.
(Main) Pink-Black	11-13 VDC	36.8-44.8 ohms	H5	6-7
(SV1) Black-Yellow	11-13 VDC	36.8-44.8 ohms	H6	5-6
(SV2) Black-Blue	11-13 VDC	36.8-44.8 ohms	H7	4-6
(SV3) Black-Brown	11-13 VDC	36.8-44.8 ohms	H8	3-6
(POV) Pink-Pink	2-15 VDC	67-81 ohms	H3	9-10

Table 12. (M) Water Flow Control Device Servo or Geared Motor.

Wire Color	Voltage	Resistance	Connector No.	Pin Nos.
Red-Blue	11-13 VDC	22-28 ohms	F7	9-10
Grey-Brown	4-6 VDC	n/a	F7	5-7
Grey-Yellow	n/a	n/a	F7	5-8

Note: The grey wire listed above turns to black at F connector on the PCB.

Table 13. (QS) Water Flow Sensor.

Wire Color	Voltage	Resistance	Connector No.	Pin Nos.
Black-Red	11-13 VDC	5.5-6.2k ohms	F2	1-3
Yellow-Black	4-7 VDC	1-1.4 Mega ohms	F2	2-3

Table 14. By-pass Flow Control (By-pass Servo Model Only).

Wire Color	Voltage	Resistance	Connector No.	Pin Nos.
Brown-White	2-6 VDC (unit in operating mode)	15-35 ohms	G1	1-5
Orange-White			G1	2-5
Yellow-White			G1	3-5
Red-White - Ground			G1	4-5

Table 15. (IG) Ignition System.

Wire Color	Voltage	Resistance	Connector No.	Pin Nos.
Grey-Grey	90-110 VAC	n/a	C1	1-2

Table 16. (FM) Combustion Fan Motor.

Wire Color	Voltage	Resistance	Connector No.	Pin Nos.
Red-Black	6-45 VDC	n/a	E1	1-2
White-Black	5-10 VDC	9.2-9.4k ohms	E1	2-4
Yellow-Black	11-13 VDC	3.5-3.9k ohms	E1	2-3

Set your meter to the hertz scale. Reading across the white and black wires at terminals 2 and 4 you should read between 60 and 420 hertz.

Table 17. Thermal Fuse / Overheat Switch.

Wire Color	Voltage	Resistance	Connector No.	Pin Nos.
Red-Red	11-13 VDC	Below 1 ohms	F6 H1	F6- H12

Flame Rod:

Place one lead of your meter to the flame rod and the other to ground. With the unit running, you should read between 5-150 VAC. Set your meter to μ amp scale and series your meter in line with the flame rod. You should read 1 μ amp or greater for proper flame circuit. In the event of low flame circuit, remove the flame rod and check for carbon or damage.

Heat Exchanger and Outgoing Water Temperature Thermistors:

Check all Thermistors by inserting meter leads into each end of the thermistor plug. Set your meter to the 20k scale and read resistance. Applying heat to the thermistor bulb should decrease the resistance. Applying ice to the thermistor bulb should increase the resistance. See below for examples of typical temperatures and resistance readings.

Example: 59°F = 11.4-14k Ω 140°F = 2.2-2.7k Ω
 86°F = 6.4-7.8k Ω 221°F = 0.6-0.8k Ω
 113° = 3.6-4.5k Ω

Table 18. Outgoing Water Thermistor.

Wire Color	Voltage	Resistance	Connector No.	Pin Nos.
White-White	n/a	See example above	F5	3-4

Table 19. Heat Exchanger Temperature Thermistor.

Wire Color	Voltage	Resistance	Connector No.	Pin Nos.
Pink-White	n/a	See example above	F4	3-11

Table 20. Intake Air Thermistor (Indoor Model Only).

Wire Color	Voltage	Resistance	Connector No.	Pin Nos.
Orange-White	n/a	See example above	F3	3-12

Table 21. Surge Protector.

Wire Color	Voltage	Resistance	Connector No.	Pin Nos.
Black-White	108-132 VAC	n/a	D2	1-3
Blue-Brown	108-132 VAC	n/a	D1	1-3

With the power off, you can check the continuity through the surge protector. Place a meter lead on the top pin #1 of the surge protector and pin #3 on the bottom of the surge protector. Check across the top pin #3 and the bottom pin #1. If you read continuity across these two points, the surge protector is good. If you do not get continuity, replace the surge protector.

Table 22. Remote Controls.

Wire Color	Voltage	Resistance	Connector No.	Pin Nos.
Terminals B1	10-13 VDC	1.5-3.0k ohms	B	1-3

Frost Protection:

This unit has frost protection heaters mounted at different points to protect the water the water heater from freezing. The heaters located on the hot water outlet line should have a resistance reading of 180-207 ohms through each of these heaters. The heater located on the heat exchanger piping should have a resistance reading of 156-180 ohms, and the one located in the water flow sensor valve should have a resistance reading of 24-28 ohms.

Amp Fuses:

This unit has two inline three-amp glass fuses. Remove the fuse and check continuity through it. If you have continuity through the fuse, it is good. Otherwise, the fuse is blown and must be replaced.

SECTION VII: OPERATING INSTRUCTIONS

WARNING

Water heaters are heat-producing appliances. To avoid damage or injury there must be no materials stored against the water heater or direct vent system, and proper care must be taken to avoid unnecessary contact (especially by children) with the water heater and direct vent system. UNDER NO CIRCUMSTANCES SHOULD FLAMMABLE MATERIALS, SUCH AS GASOLINE OR PAINT THINNER BE USED OR STORED IN THE VICINITY OF THIS WATER HEATER OR IN ANY LOCATION FROM WHICH FUMES COULD REACH THE WATER HEATER.

Installation or service of this water heater requires ability equivalent to that of a licensed tradesman in the field involved. Plumbing, air supply, venting, gas supply, and electrical work are required.

Light the unit in accordance with the operation instructions label attached to the water heater.

Under no circumstances should the input rate exceed the input rate shown on the water heater rating plate. Over firing could result in damage or sooting of the water heater.

If the unit is exposed to the following, do not operate water heater until all corrective steps have been made by a factory authorized independent service contractor or qualified service professional.

1. Flooding to or above the level of the burner or controls
2. External firing
3. Damage
4. Firing without water
5. Sooting

Never operate the water heater without first being certain it is filled with water and a pressure relief valve is installed in the HOT WATER OUTLET PIPING of the WATER heater.

GENERAL INSTRUCTIONS

TO FILL THE WATER HEATER

1. Close the water heater drain valve by turning the knob or valve stem clockwise.
2. Open the cold water supply shut-off valve.
3. Open several hot water faucets to allow air to escape from the system.
4. When a steady stream of water flows from the faucets, the water heater is filled. Close the faucets and check for water leaks at the water heater drain valve, pressure relief valve, and the hot and cold water connections.

SEQUENCE OF OPERATION

1. Water heater senses the minimum operating water flow which starts the ignition sequence to light the burners.
2. Blower ON
3. Gas valve opens and spark igniter starts.
4. Main burner ON
5. Flame signal confirmed
6. Burner flame and combustion blower modulates to maintain selected outlet temperature
7. Water flow is also regulated to not exceed the capacity of the water heater for the temperature selected.
8. Water flow shuts off.
9. Burners shut off immediately, but combustion blower continues for another 65 seconds to purge heat from coil.

LIGHTING INSTRUCTIONS

FOR YOUR SAFETY READ BEFORE OPERATING	
WARNING: If you do not follow these instructions exactly, a fire or explosion may result causing property damage, personal injury or loss of life.	
<p>A. This water heater does not have a pilot. It is equipped with a direct ignition device, which automatically lights the burner. Do not try to light the burner by hand.</p> <p>B. BEFORE OPERATING: Smell all around the appliance area for gas. Be sure to smell next to the floor, because some gas is heavier than air and will settle on the floor.</p> <p>WHAT TO DO IF YOU SMELL GAS</p> <ul style="list-style-type: none"> • Do not try to light any appliance. • Do not touch any electric switch; do not use any phone in your building. 	<ul style="list-style-type: none"> • Immediately call your gas supplier from a neighbor's phone. Follow the gas supplier's instructions. • If you cannot reach your gas supplier, call the fire department. <p>C. Use only your hand to operate the remote control keypad. Never use tools. If the remote keypad doesn't work, do not try to repair it, call a qualified service technician. Forced or improper repair may result in a fire or explosion.</p> <p>D. Do not use this water heater if any part has been under water. Immediately call a qualified service technician to inspect the water heater and to replace any part of the control system and any gas control which has been under water.</p>
OPERATION INSTRUCTIONS	
<ol style="list-style-type: none"> 1. STOP! Read the safety information above before proceeding. 2. Set the thermostat to the lowest setting. 3. Turn off all power to the electrical appliance. 4. This water heater does not have a pilot. It is equipped with a direct ignition device, which automatically lights the burner. Do not try to light the burner by hand. 5. Turn the manual valve located at the gas inlet of the appliance clockwise to "OFF" (See Figure 16). 	<ol style="list-style-type: none"> 6. Wait (5) minutes to clear out any gas. If you then smell gas, STOP! Follow "B" in the safety information above on this label. If you don't smell gas, go to next step. 7. Turn the manual valve located at the gas inlet of appliance counterclockwise to "ON" (See Figure 16). 8. Turn on all electric power to the appliance. 9. Set the thermostat to desired setting. 10. If the appliance will not operate, Follow the instructions "To Turn Off Gas To Appliance" and call your service technician or gas supplier.
TO TURN OFF GAS TO THE APPLIANCE	
<ol style="list-style-type: none"> 1. Set the thermostat to the lowest setting. 2. Turn off all electric power to the appliance if service is to be performed. 	<ol style="list-style-type: none"> 3. Turn the manual valve at gas inlet of appliance clockwise to "OFF" (See Figure 16).

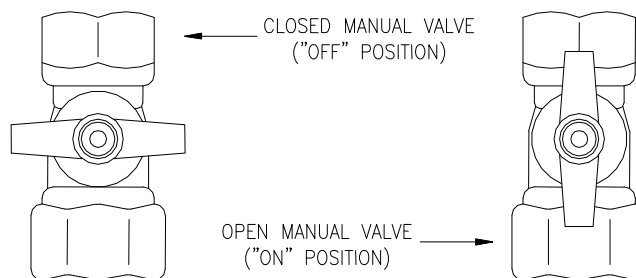

Figure 16. Manual Gas Valve.

CAUTION

In climates where below freezing temperatures may occur, the water heater must be drained when power is off to the water heater to prevent freeze damage to the heat exchanger. Drain solenoids are recommended to prevent freeze damage during power failures in cold climate regions.

TURNING OFF THE WATER HEATER FOR AN EXTENDED PERIOD OF TIME

If the EverHot® water heater is to be turned off for an extended period of time, the following steps should be taken.

1. Turn the gas shutoff valve on the gas supply inlet to the OFF position (See Figure 16).
2. Disconnect the electrical supply to the water heater.
3. Shut off the cold water supply to the water heater and open the drain valve to drain the water heater. If the water heater was installed with drain solenoid freeze protection, the water heater will drain automatically when power is disconnected.

TEMPERATURE ADJUSTMENT

DANGER

Hotter water increases the risk of scald injury. Scalding may occur within 5 seconds at a temperature setting of 140°F (60°C). To protect against hot water injury, install a mixing valve in the water system. This valve will reduce point of discharge temperature by mixing cold and hot water in branch water lines. A licensed plumbing professional or local plumbing authority should be consulted.

CAUTION

This water heater, when set at a lower temperature setting is not capable of producing hot water of sufficient temperature for sanitizing purposes. Always check water temperature by hand before entering the shower or bath. The temperature may have been changed.

NOTICE

This water heater is equipped with an energy cut out device to prevent overheating. Should overheating occur or the gas supply fails to shut off, turn off the manual gas control valve to the water heater and call a qualified service agent.

NOTICE

The lower the temperature setting, the greater the energy efficiency to heat the water. Lower water temperatures also extend the heat exchanger life. Remember, no water heating system will provide exact temperatures at all times. Allow a few days of operation at this setting to determine the correct temperature setting consistent with the requirements for the installation.

1. The outlet water temperature of the EverHot water heaters is adjusted using the main control located on the front panel of the water heater (or optional remote controls). When a remote temperature control is installed, the temperature can only be adjusted on the control that has the Priority Indicator Light glowing. The temperature displayed on the control in use will also be displayed on all the other remote controls.

2. To set the desired temperature on the control, all hot water faucets must be closed. If there are remote controls installed, press the "Priority" button on the control you want to change the setting on and the "Priority" indicator light will glow.
3. Press the "H" or "C" button until the required temperature is displayed on the digital monitor. The default available water temperature range for the main control is 98-120°F.
4. To operate the water heater, simply turn any hot water tap on. This will automatically light the burner and provide hot water at the preset temperature. If the optional remote controls have been installed, the "IN USE" indicator light will glow on all remote controls.
5. The control(s) can also display diagnostic codes, water flow rate through the unit (in gallons per minute) and the outlet water temperature.
6. Press and hold the "Priority" button for 2 seconds and without releasing, press the "H" button to display a sequence of up to 9 diagnostic codes, if any, stored in memory that has been experienced. Any diagnostic codes will be displayed on the digital monitor in sequence starting with the most recent code.
7. Press and hold the "H" button for 2 seconds and without releasing, press the "Priority" button to display the water flow through the water heater with hot water in use (GPM = Display Readout X 0.1).
8. Press and hold the "C" button for 2 seconds and without releasing, press the "Priority" button to display the outlet water temperature while in use (degrees F).

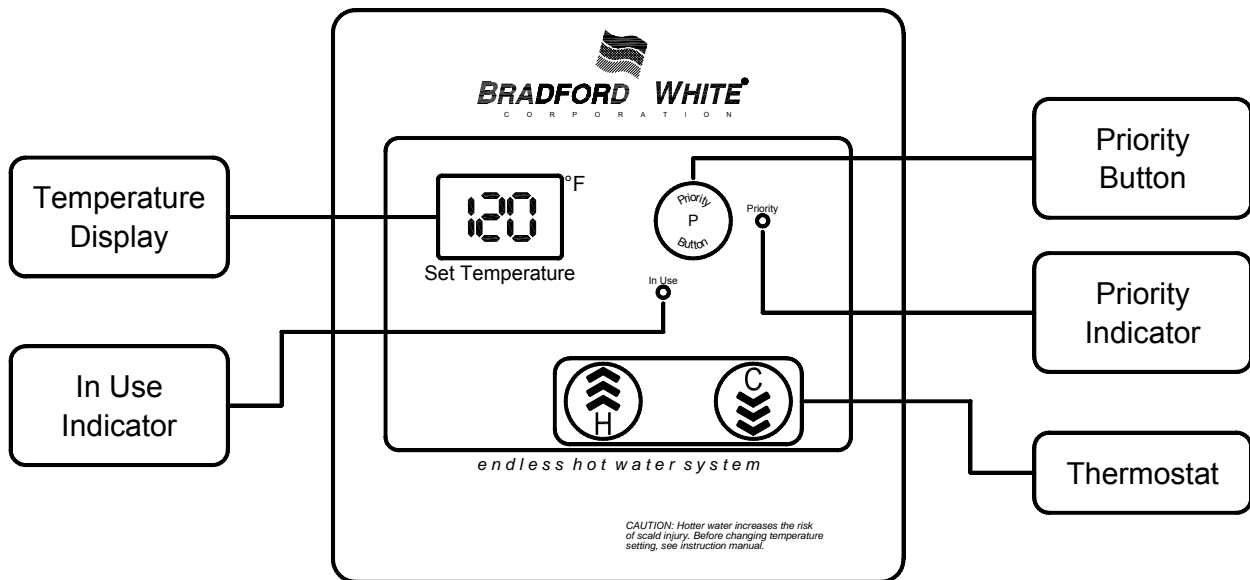

Figure 17. Remote Control and the Description of Functions on All Controls.

NOTICE

The temperature can only be adjusted between 96°F and 110°F when the hot water tap is open and hot water is flowing. This is a safety feature to prevent scalding while hot water is in use.

NOTICE

The default temperature setting that will appear when the water heater is first connected to the electrical supply is 104°F. In the event of a power interruption, the unit will retain its set temperature for up to 6 hours. If the power is interrupted for more than 6 hours, the unit will revert back to a temperature of 104°F.

SCALDING

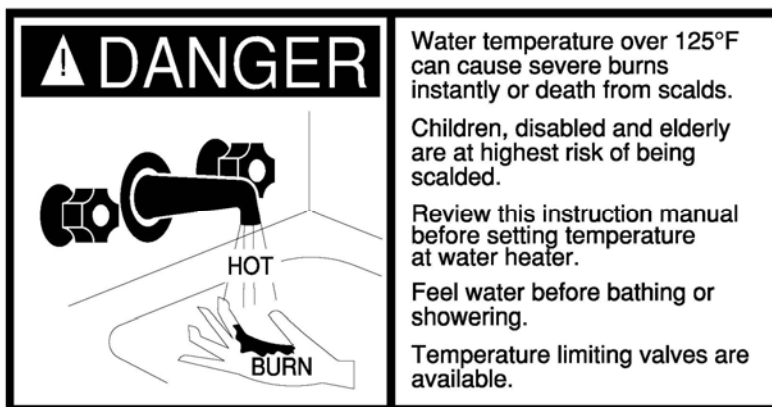

Figure 18. Scalding Warning.

This water heater can deliver scalding temperature water at any faucet in the system. Be careful whenever using hot water to avoid scalding injury. Certain appliances, such as dishwashers and automatic clothes washers may require increased water temperature. By setting the thermostat on this water heater to obtain the increased temperature water required by these appliances, you may create the potential for scald injury. To protect against injury, you should install a tempering valve in the water system. This valve will reduce point of discharge temperature by mixing cold and hot water in branch supply lines. Such valves are available from the local plumbing supplier.

! CAUTION

Test the temperature of the water with your elbow before placing a child in the bath or shower. Do not leave a child or an infirm person in the bath unsupervised.

The following chart details the relationship of water temperature and time with regard to scald injury and may be used as a guide in determining the safest water temperature for your applications.

Table 23. Relationship Between Exposure to Hot Water and When a Scald Results.

APPROXIMATE TIME/TEMPERATURE RELATIONSHIPS IN SCALDS	
120°F (49°C)	More than 5 minutes
125°F (52°C)	1½ to 2 minutes
130°F (54°C)	About 30 seconds
135°F (57°C)	About 10 seconds
140°F (60°C)	Less than 5 seconds
145°F (63°C)	Less than 3 seconds
150°F (66°C)	About 1½ seconds
155°F (68°C)	About 1 second

FIRST AID FOR SCALDS

1. Apply cold water to burned area for 30 minutes to reduce the heat in the skin and prevent deeper burning. Never use butter, oils, or ointment to cover the burn. They may retain the heat.
2. Use a blanket to keep the scalded person warm.
3. Seek medical advice.

DIAGNOSTIC CODES ON THE TEMPERATURE CONTROL DISPLAY

The Bradford White EverHot® tankless water heaters have the ability to monitor and display any operating faults on the control display. The diagnostic codes will display on the monitor and will assist in servicing the water heater. The following is a listing of the diagnostic codes, which may flash on the monitor in case of a malfunction with the water heater. Please quote the code displayed when calling for service.

Code	Code Description	Remedy
02	No burner operation during freeze protection mode	Service Call
03	Power interruption during Bath Fill (Water will not flow when power returns).	Turn off all hot water taps. Press ON/OFF twice.
10	Air Supply or Exhaust Blockage	Check that nothing is blocking the flue inlet or exhaust. Check all vent components for proper connections. Ensure vent length is within limits. Ensure condensation collar was installed correctly. Verify dip switches are set properly. Check fan for blockage.
11	No Ignition	Check that the gas is turned on at the water heater, gas meter, or cylinder. Ensure gas type and pressure is correct. Ensure gas line, meter, and/or regulator is sized properly. Bleed all air from gas lines. Verify dip switches are set properly. Ensure water heater is properly grounded. Disconnect Manifold Electronic Controls to isolate the problem. Ensure igniter is operational. Check igniter wiring harness for damage. Check gas solenoid valves for open or short circuits. Remove burner cover and ensure all burners are properly seated. Remove burner plate and inspect burner surface for condensation or debris.
12	Flame Failure	Check that the gas is turned on at the water heater and gas meter. Check for obstructions in the flue outlet. Ensure gas line, meter, and/or regulator is sized properly. Ensure gas type and pressure is correct. Bleed all air from gas lines. Ensure condensation collar was installed properly. Ensure vent length is within limits. Verify dip switches are set properly. Ensure water heater is properly grounded. Disconnect keypad. Disconnect Manifold Electronic Controls to isolate the problem. Check power supply for loose connections. Check power supply for proper voltage and voltage drops. Ensure flame rod wire is connected. Check flame rod for carbon build-up. Disconnect and reconnect all wiring harnesses on unit and PC board. Check for DC shorts at components. Check gas solenoid valves for open or short circuits. Remove burner plate and inspect burner surface for condensation or debris.
14	Thermal Fuse	Check gas type of unit and ensure it matches gas type being used. Check for restrictions in air flow around unit and vent terminal. Check for low water flow in a circulating system causing short-cycling. Ensure dip switches are set to the proper position. Check for foreign materials in combustion chamber and/or exhaust piping. Check heat exchanger for cracks and/or separations. Check heat exchanger surface for hot spots which indicate blockage due to scale build-up. Refer to instructions in manual for flushing heat exchanger. Measure resistance of safety circuit. Ensure high fire and low fire manifold pressure is correct. Check for improper conversion of product.

Code	Code Description	Remedy
16	Over Temperature Warning	Check for restrictions in air flow around unit and vent terminal. Check for low water flow in a circulating system causing short-cycling. Check for foreign materials in combustion chamber and/or exhaust piping. Check for clogged heat exchanger.
32	Outgoing Water Temperature Sensor Fault	Check sensor wiring for damage. Measure resistance of sensor. Clean sensor of scale build-up. Replace sensor.
33	Heat Exchanger Outgoing Temperature Sensor Fault	Check sensor wiring for damage. Measure resistance of sensor. Clean sensor of scale build-up. Replace sensor.
34	Combustion Air Temperature Sensor Fault	Check for restrictions in air flow around unit and vent terminal. Check sensor wiring for damage. Measure resistance of sensor. Clean sensor of scale build-up. Ensure fan blade is tight on motor shaft and is in good condition. Replace sensor.
52	Modulating Solenoid Valve Signal Abnormal	Check modulating gas solenoid valve wiring harness for loose or damaged terminals. Measure resistance of valve coil.
61	Combustion Fan Failure	Ensure fan will turn freely. Check wiring harness to motor for damaged and/or loose connections. Measure resistance of motor winding.
65	Water Flow Control Fault	The water flow control valve has failed to close during the bath fill function. Immediately turn off the water and discontinue the bath fill function. Contact a state qualified or licensed contractor to service the water heater.
71	SV0, SV1, SV2, and SV3 Solenoid Valve Circuit Fault	Check wiring harness to all solenoids for damage and/or loose connections. Measure resistance of each solenoid valve coil.
72	Flame Sensing Device Fault	Ensure flame rod is touching flame when unit fires. Check all wiring to flame rod for damage. Remove flame rod and check for carbon build-up; clean with sand paper. Check inside burner chamber for any foreign material blocking flame at flame rod. Measure micro amp output of sensor circuit with flame present. Replace flame rod.
LC	Scale Build-up in Heat Exchanger (when checking maintenance code history, "00" is substituted for "LC")	Flush heat exchanger. Refer to instructions in manual. Replace heat exchanger. NOTE: The LC code is the only error code that will allow the unit to keep running. The display will alternate between the LC code and the temperature setting. The controller will continue to beep. The LC code will reset if power is turned off and then on.
No code	Nothing happens when water flow is activated.	Clean inlet water supply filter. On new installations ensure hot and cold water lines are not reversed. Check for bleed over. Isolate unit from building by turning off hot water line to building. Isolate the circulating system if present. Open your pressure relief valve; if water is flowing, there is bleed over in your plumbing. Ensure you have at least the minimum flow rate required to fire unit. Ensure turbine spins freely. Measure the resistance of the water flow control sensor. Check for DC shorts at components.

If any of the above diagnostic codes are seen flashing on the display, call for service.



WARNING

Failure to remedy faults may result in severe burns, scalds, and/or death.

SECTION VIII: MAINTENANCE

WARNING

Always turn off the electrical power supply, the manual gas valve, and the manual water control valve whenever servicing this appliance.

KEEP THE WATER HEATER AREA CLEAR AND FREE FROM COMBUSTIBLE MATERIALS, GASOLINE, AND OTHER FLAMMABLE VAPORS AND LIQUIDS.

The EverHot® water heater should be checked annually by a qualified technician. Regular maintenance will keep the water heater operating efficiently and help to assure reliable operation and a long service life.

1. Remove and clean the inlet water filter screen. If a Y-type strainer or cartridge filter is used on the cold water inlet to the water heater, inspect or clean as needed to assure full water flow to the water heater.
2. Visually inspect the burner flames. The flame must burn with a clear blue, stable flame (possibly with orange tips). Refer to Figure 19 for satisfactory flame appearance. If the burner flame appearance is not satisfactory or debris is visible on the burners, remove and clean with a vacuum cleaner.

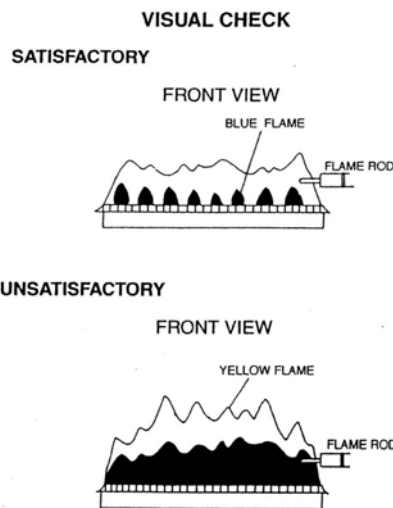

Figure 19. Burner Flame Appearance.

3. Check the front vent outlet for blockage and clean, if necessary. Keep shrubs and vegetation clear of the vent terminal.
4. All electric motors are permanently lubricated and do not need oiling. Remove the combustion air blower and clean wheel and housing with soft brush or vacuum.
5. If the “LC” code has been flashing on the display, the heat exchanger will need flushing to remove lime and scale deposits. Refer to the “Flushing Procedure for Lime Scale Removal...” in Section VIII, “Maintenance.”
6. Check operation of the pressure relief valve. To check the relief valve, lift the lever at the end of the valve several times. The valve should seat properly and operate freely. If water does not flow, remove and inspect for obstructions or corrosion. Replace with a new valve of the recommended size as necessary. A thorough inspection of the valve should be performed at least every three years by removing the pressure relief valve from the outlet piping. Do not attempt to repair the valve, as this could result in improper operation and explosion of the heat exchanger and piping. In areas with poor water conditions, it may be necessary to inspect the pressure relief valve more often than the recommended maintenance schedule.

CAUTION

Before manually operating the valve, make sure that a drain line has been attached to the valve to direct the discharge to an open drain. Failure to take this precaution could mean contact with extremely hot water passing out the valve during this checking operation.

FLUSHING PROCEDURE FOR MINERAL SCALE REMOVAL FROM HEAT EXCHANGER

The amount of calcium carbonate (minerals) released from water is in direct proportion to water temperature and usage. The higher the water temperature or water usage and the harder the water (more dissolved calcium carbonate), the more mineral deposits are dropped out of the water. This is the mineral scale that forms in pipes, water heaters, and on cooking utensils.

Mineral accumulation reduces the efficiency and longevity of the heat exchanger coil and will cause the water heater to malfunction. The mineral scale may need to be periodically removed from the heat exchanger (indicated by the "LC" code on the remote display). The usage of water softening equipment greatly reduces the hardness of the water. However, this equipment does not always remove all of the hardness (minerals). The heat exchanger may occasionally need to be flushed to clear out the mineral deposits. Use the following procedure and Figure 20 to flush the heat exchanger and remove the mineral scale.

1. Disconnect power to the water heater.
2. Close the shut-off valves in the cold water inlet and outlet supply (V3 and V4).
3. Connect pump outlet hose (H1) to the cold water line at valve (V2). Connect drain hose (H3) to valve (V1).
4. Pour 4 gallons of virgin, food grade, white vinegar or citric acid into a 5 gallon bucket.
5. Place the drain hose (H3) and the hose (H2) to the pump inlet into the cleaning solution.
6. Open the both valves (V1 and V2) to the hot and cold water lines.
7. Turn on power to the circulating pump and allow the vinegar to circulate through the heat exchanger coil for at least 45 minutes. Heat exchangers containing a considerable amount of minerals may require several hours.
8. Turn off power to the circulating pump.
9. Remove the free end of the drain hose (H3) from the pail and route it to a drain.
10. Close the valve (V2) and open shut-off valve (V4). Do not open shut-off valve (V3).
11. Allow water to flow out of the hose for 5 minutes to flush vinegar from the water heater.
12. Close service valve (V1) and open shut-off valve (V3).
13. Disconnect the hoses from the valve connections.
14. With (V4) closed, remove the in-line filter at the cold water inlet and clean out any residue. Place the filter back into unit and open (V4).
15. Restore power to the water heater and check operation.

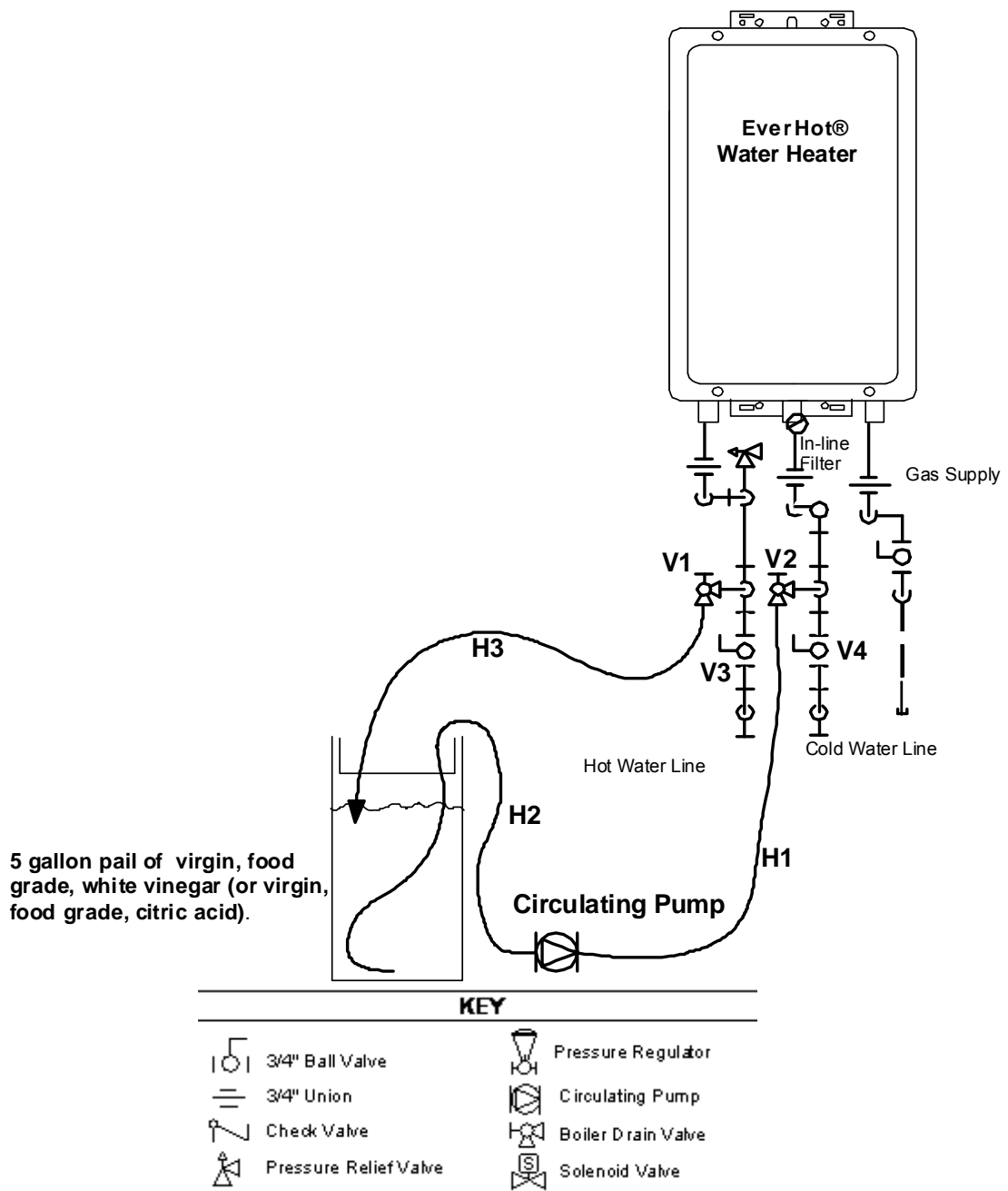

Figure 20. Piping for Mineral Scale Flushing.

Common Troubleshooting Comments on the Operation of the EverHot® Tankless Water Heater

Comment: I don't have any hot water when I open the tap!

Make sure the gas and electricity is turned on to the water heater. The temperature display should have the green light lit when a hot water tap is open and the water heater is operating. Make sure there are no diagnostic codes flashing on the display.

Comment: When I was using the hot water, the water got cold!

If you reduced the hot water flow from the tap, you may have reduced the flow below the minimum flow to operate the water heater. If you mix the hot water with cold water at the tap in an attempt to get a temperature below the temperature being produced by the water heater, the hot water flow through the water heater may drop below the minimum flow required to operate the water heater. To remedy this situation, either increase the total water flow from the tap or using the control, decrease the setpoint temperature of the water heater to the temperature desired at the tap.

Comment: White smoke comes out of the exhaust!

During colder weather when the exhaust temperature is much hotter than the ambient air, the moist exhaust gases condense producing a white vapor cloud.

Comment: When I open a hot water faucet I do not immediately get hot water!

Hot water must travel through the plumbing piping to the faucet. This may take from 10 to 30 seconds depending upon the length of cold plumbing pipe the water must travel through.

Comment: After I turn off the hot water tap, the fan on the water heater continues to run!

The fan is designed to continue to run for 65 seconds after the flow of water stops. This is to ensure constant water temperature during frequent short water draws (such as washing dishes), as well as exhausting residual heat and flue gases from the water heater and venting system.

SECTION IX: PARTS LIST

TG-150E, TG-180E, and TG-199E Models

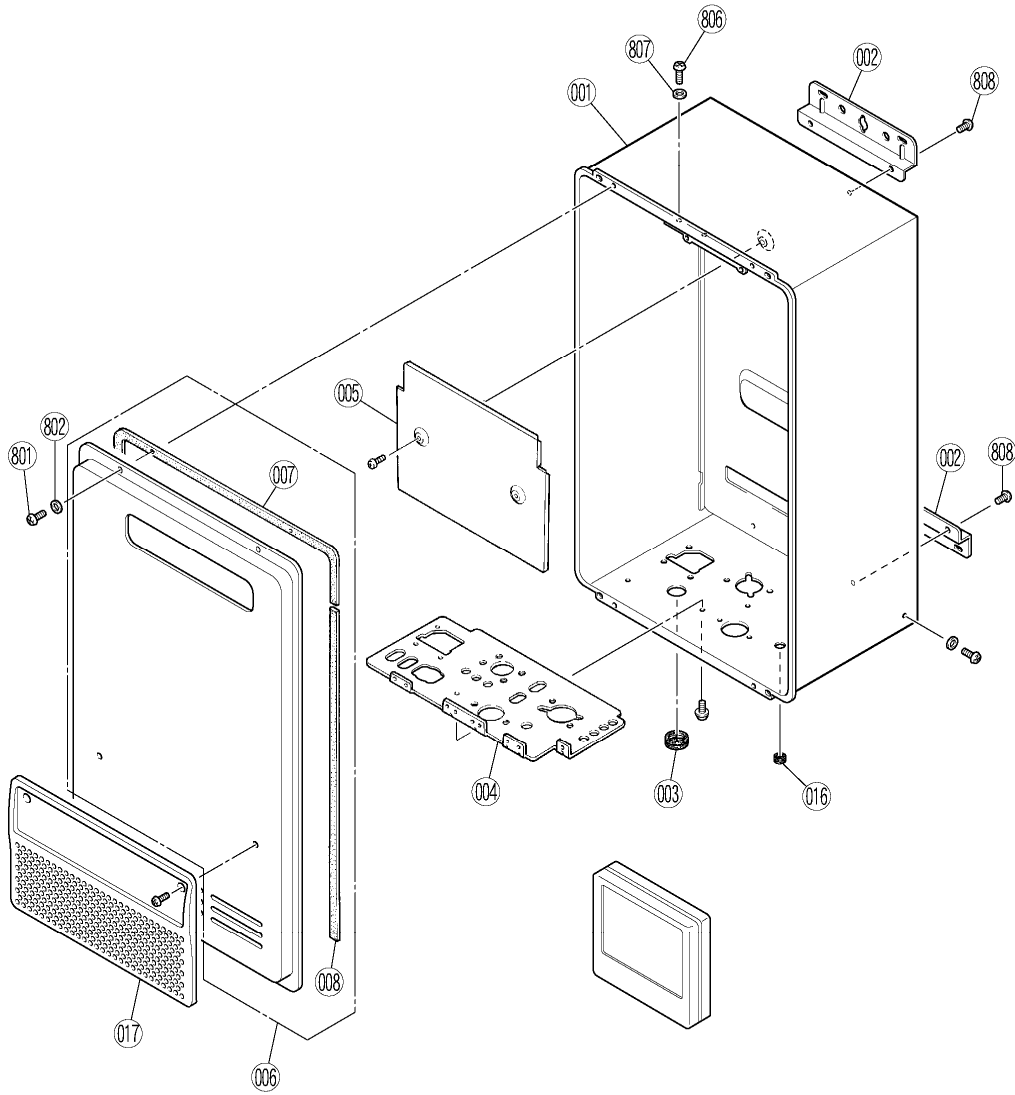

		TG-199E-N	TG-199E-X	TG-180E-N	TG-180E-X	TG-150E-N	TG-150E-X
No	Description	Quantity					
001	Main Body	1	1	1	1	1	1
002	Wall Fitting Bracket	2	2	2	2	2	2
003	Rubber Bushing	1	1	1	1	1	1
004	Connection Reinforcement Panel	1	1	1	1	1	1
005	Heat Protection Plate	1	1	1	1	1	1
006	Front Panel	1	1	1	1	1	1
007	Front Panel Packing	1	1	1	1	1	1
008	Main Body Packing Side	2	2	2	2	2	2
016	Rubber Bushing	1	1	1	1	1	1
017	Decoration Panel	1	1	1	1	1	1
801	Screw	4	4	4	4	4	4
802	Resin Washer	4	4	4	4	4	4
806	Screw	2	2	2	2	2	2
807	Resin Washer	2	2	2	2	2	2
808	Screw	4	4	4	4	4	4

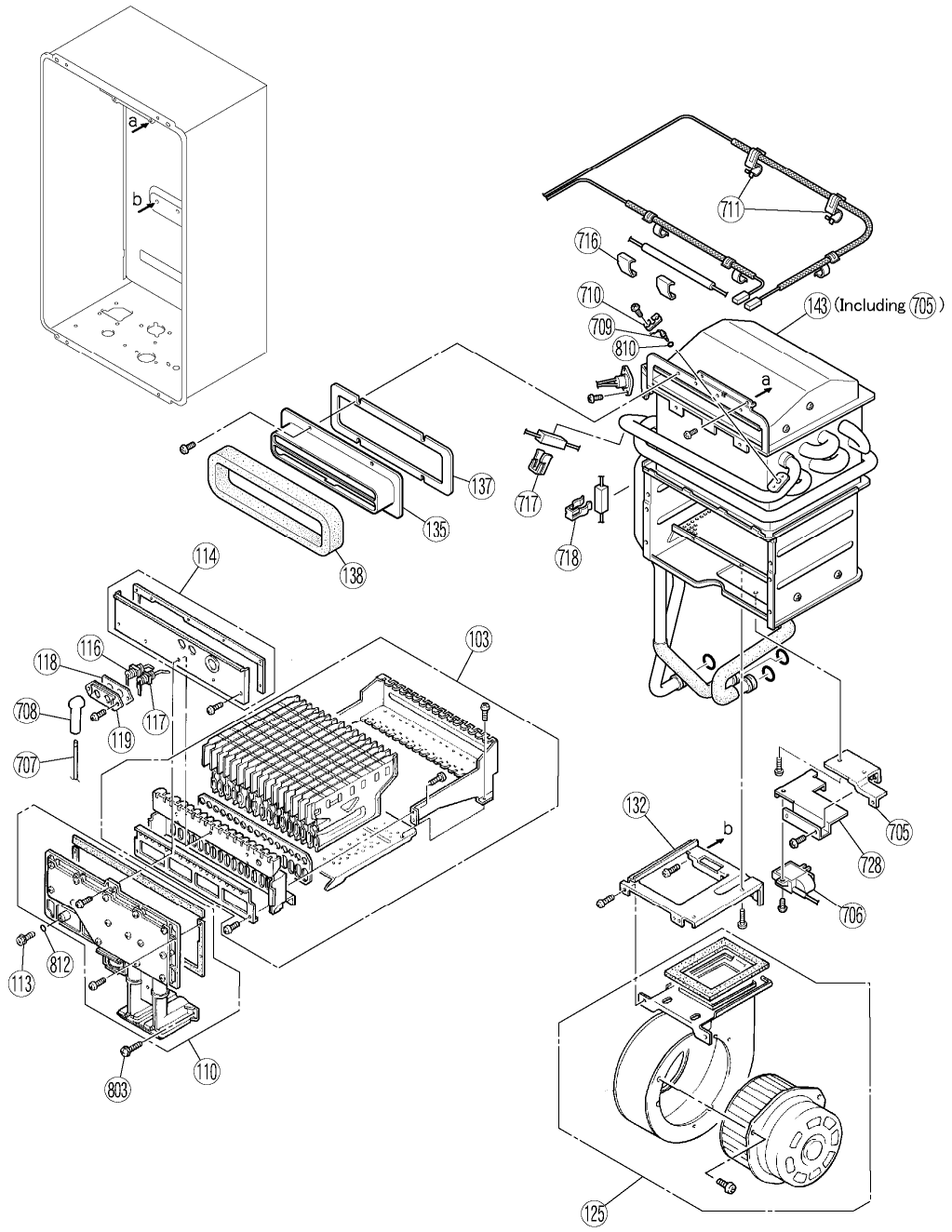

No	Description	Quantity					
		TG-199E-N	TG-199E-X	TG-180E-N	TG-180E-X	TG-150E-N	TG-150E-X
103	24 Burner Unit Assembly (LPG)	-	1	-	1	-	1
103	24 Burner Unit Assembly (NG)	1	-	1	-	1	-
110	Manifold Assembly (LPG)	-	1	-	1	-	1
110	Manifold Assembly (NG)	1	-	1	-	1	-
113	Pressure Point Sealing Screw	1	1	1	1	1	1
114	Combustion Chamber Front Panel	1	1	1	1	1	1
116	Electrode	1	1	1	1	1	1
117	FR Electrode	1	1	1	1	1	1
118	Electrode Packing	1	1	1	1	1	1
119	Electrode Holder	1	1	1	1	1	1
125	Fan Motor All Assembly	1	1	1	1	1	1
132	Combustion Chamber Bracket	1	1	1	1	1	1
135	Air Inlet Box All Assembly	1	1	1	1	1	1
137	Connecting Joint	1	1	1	1	1	1
138	Joint Fixing Bracket	1	1	1	1	1	1
143	Heat Exchanger Assembly	1	1	-	-	-	-
143	Heat Exchanger Assembly	-	-	1	1	1	1
705	Electric Unit Fixing Plate	1	1	1	1	1	1
706	Sparker	1	1	1	1	1	1
707	High Tension Cord	1	1	1	1	1	1
708	Electrode Sleeve	1	1	1	1	1	1
709	Thermistor	1	1	1	1	1	1
710	Retainer (large)	1	1	1	1	1	1
711	Temperature Fuse Fixing Plate	5	5	5	5	5	5
716	Heater Fixing Plate	2	2	2	2	2	2
717	Heater Fixing Plate A	1	1	1	1	1	1
718	Heater Fixing Plate	1	1	1	1	1	1
728	Sparker Bracket	1	1	1	1	1	1
803	Screw	3	3	3	3	3	3
810	O-ring	2	2	2	2	2	2
812	O-ring	1	1	1	1	1	1

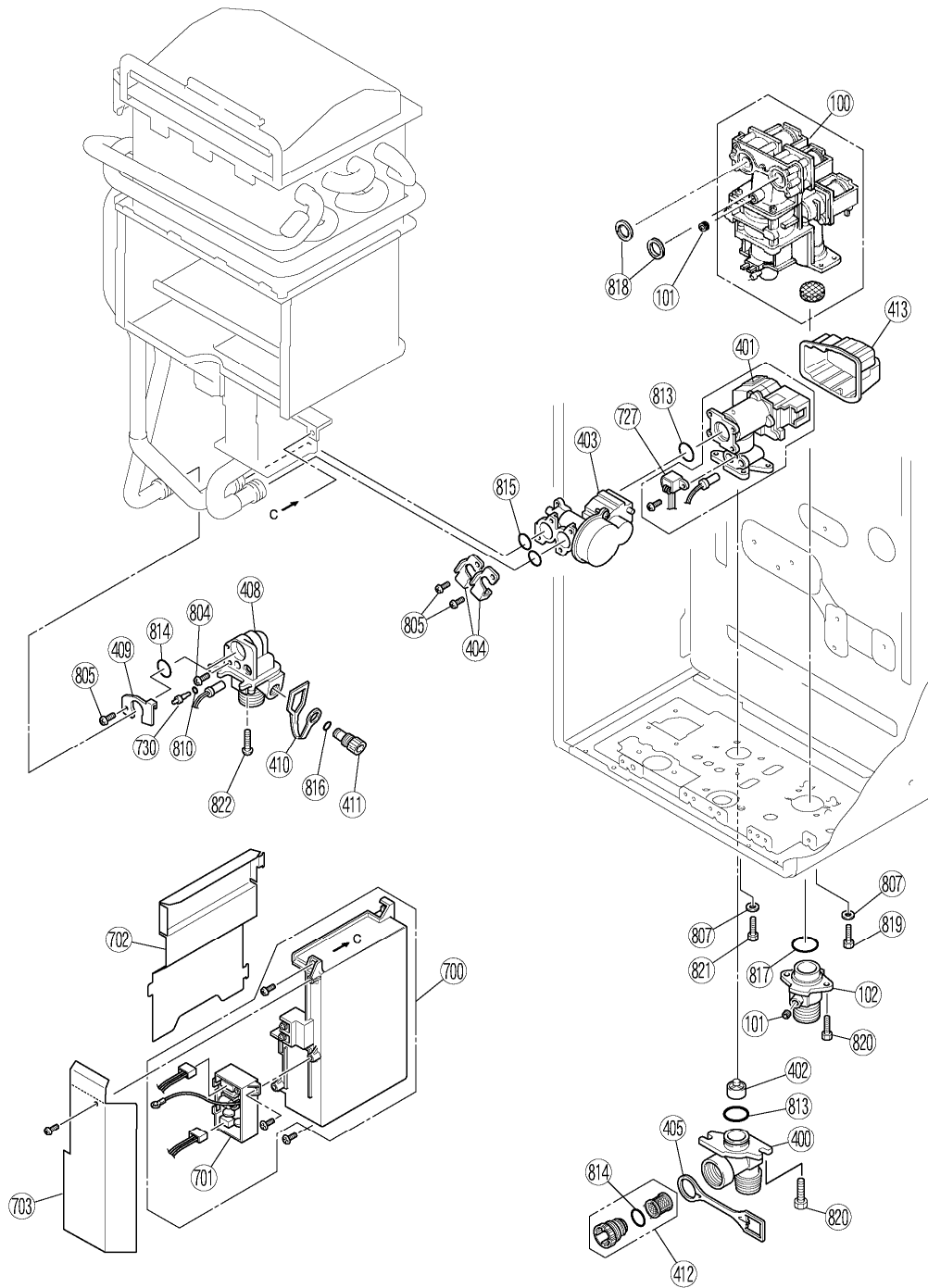

No	Description	TG-199E-N	TG-199E-X	TG-180E-N	TG-180E-X	TG-150E-N	TG-150E-X
		Quantity					
100	Gas Control Assembly	1	1	1	1	1	1
101	Blind Screw	2	2	2	2	2	2
102	3/4 Gas Inlet	1	1	1	1	1	1
400	3/4 Water Inlet B	1	1	1	1	1	1
401	Water Flow Servo & Sensor Assembly	1	1	-	-	-	-
401	Water Flow Servo & Sensor Assembly	-	-	1	1	1	1
402	Rectifier	1	1	1	1	1	1
403	By-pass Servo Assembly	1	1	-	-	-	-
404	Stop Bracket	2	2	-	-	-	-
404	Stop Bracket	-	-	1	1	1	1
405	Plug Band	1	1	1	1	1	1
408	3/4 Hot Water Outlet	1	1	1	1	1	1
409	Stop Bracket	1	1	1	1	1	1
410	Plug Band (small)	1	1	1	1	1	1
411	Drain Valve	1	1	1	1	1	1
412	Filter Plug Assembly	1	1	1	1	1	1
413	Cover	1	1	1	1	1	1
700	Electric Unit Assembly	1	1	-	-	-	-
700	Electric Unit Assembly	-	-	1	1	1	1
701	Surge Protector	1	1	1	1	1	1
702	Electric Unit Cover	1	1	1	1	1	1
703	EC Cover	1	1	1	1	1	1
727	MR Sensor	1	1	1	1	1	1
730	Thermistor	1	1	1	1	1	1
804	Thermistor Stop Screw	1	1	1	1	1	1
805	Screw	3	3	2	2	2	2
807	Resin Washer	2	2	2	2	2	2
810	O-ring	2	2	2	2	2	2
813	O-ring	2	2	1	1	1	1
814	O-ring	1	1	1	1	1	1
815	O-ring	2	2	1	1	1	1
816	O-ring	1	1	1	1	1	1
817	O-ring	1	1	1	1	1	1
818	Packing	2	2	2	2	2	2
819	Screw	2	2	2	2	2	2
820	Screw	4	4	4	4	4	4
821	Screw	2	2	2	2	2	2
822	Screw	3	3	3	3	3	3

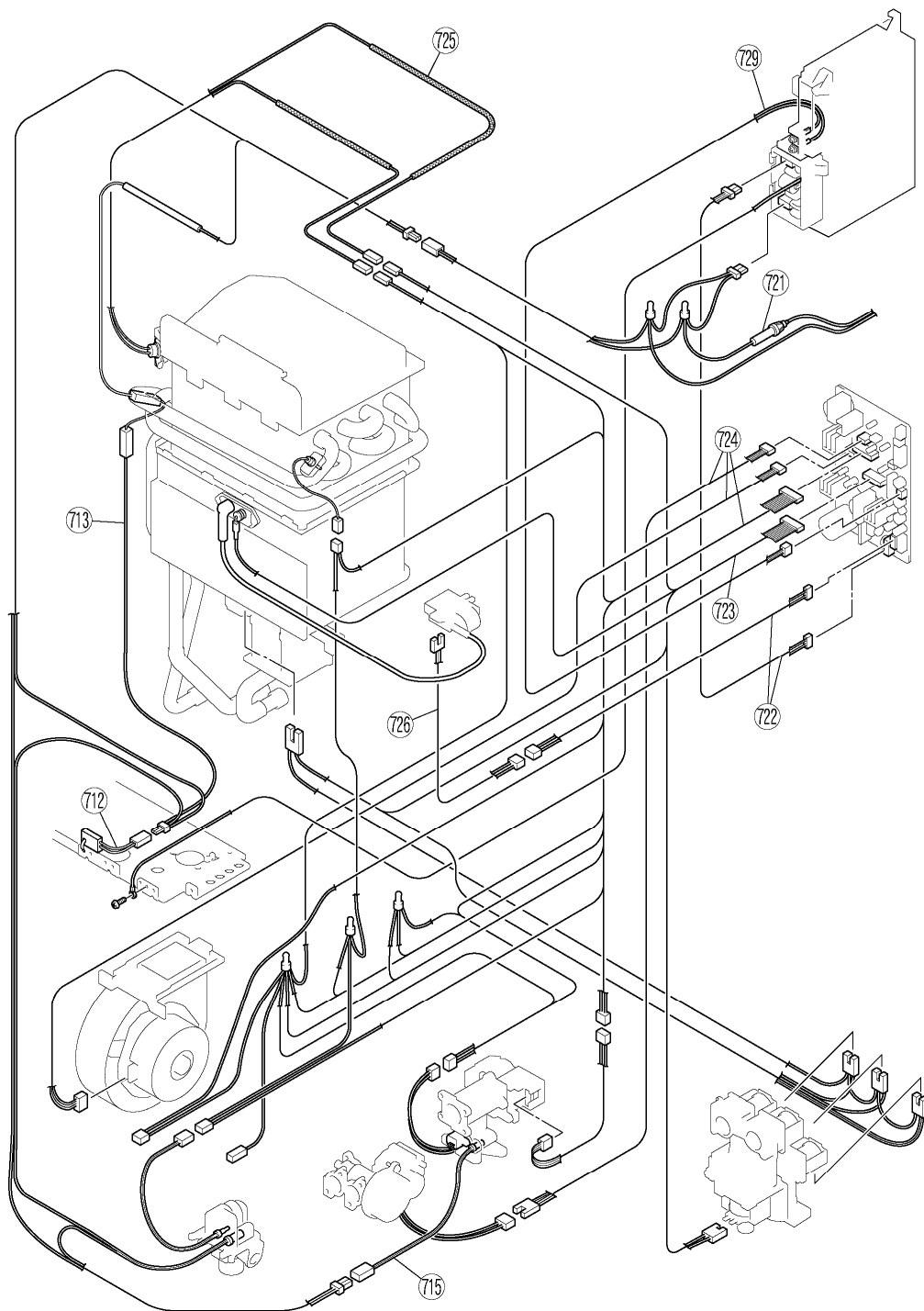

No	Description	TG-199E-N	TG-199E-X	TG-180E-N	TG-180E-X	TG-150E-N	TG-150E-X
		Quantity					
712	Frost Sensing Switch	1	1	1	1	1	1
713	Anti Frost Heater (120V)	1	1	1	1	1	1
715	Valve Heater (120V) Assembly	1	1	1	1	1	1
721	Fuse Harness(FF)	1	1	1	1	1	1
722	Power Harness	1	1	1	1	1	1
723	Magnet Valve Harness	1	1	1	1	1	1
724	Sensor Harness	1	1	-	-	-	-
724	Sensor Harness	-	-	1	1	1	1
725	Thermal Fuse Harness	1	1	1	1	1	1
726	Sparker Harness	1	1	1	1	1	1
729	Remote Controller Harness	1	1	1	1	1	1

TG-237E Models

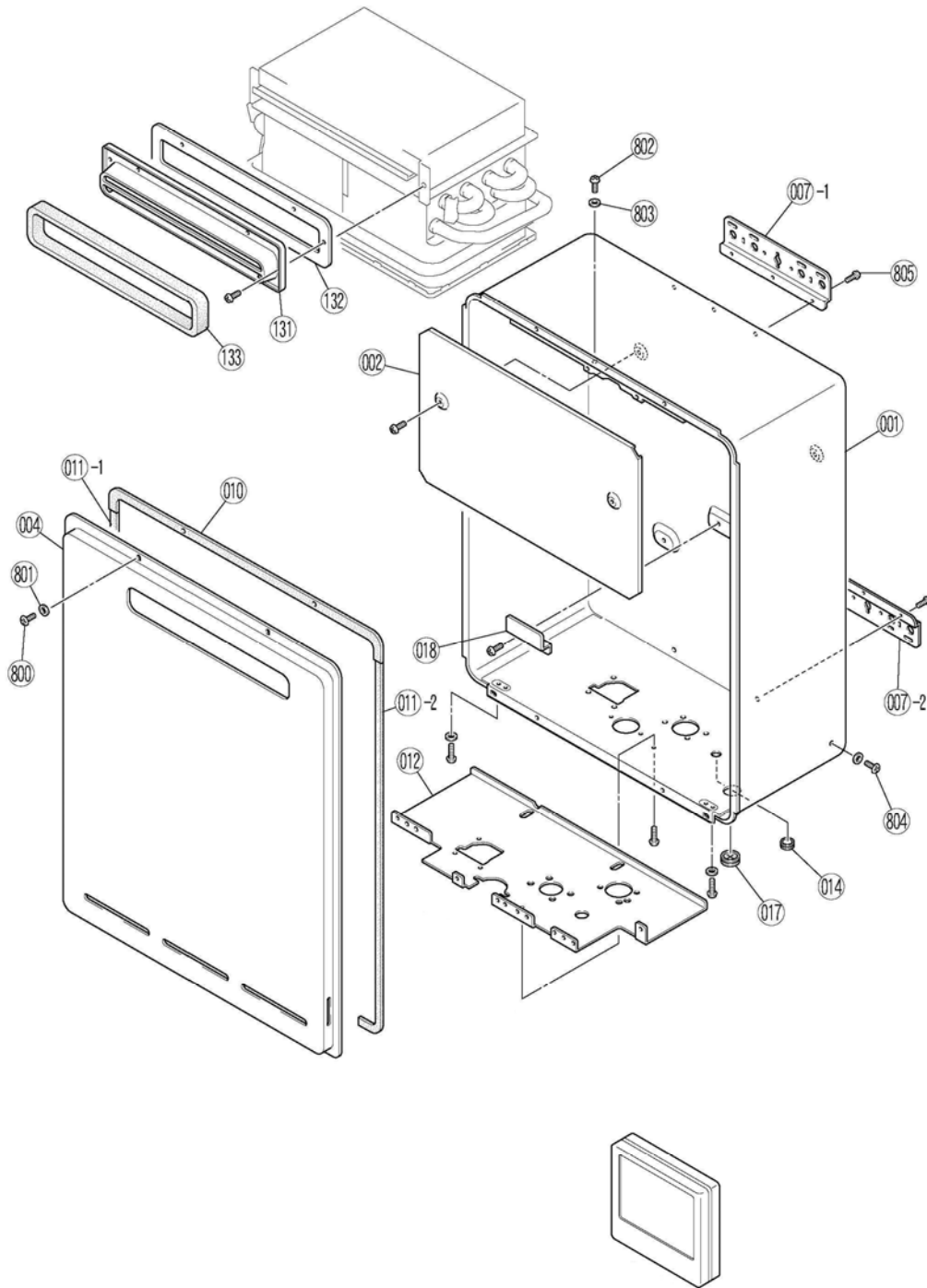

No	Description	TG-237E-N	TG-237E-X	TG-237E-NA	TG-237E-XA
		Quantity			
001	Main Body	1	1	1	1
002	Heat Protection Plate	1	1	1	1
004	Front Panel Assembly	1	1	1	1
007	Wall Fitting Bracket	2	2	2	2
010	Front Panel Packing-Top	2	2	2	2
011	Front Panel Packing-Side	2	2	2	2
012	Connection Reinforcement Panel	1	1	1	1
014	Seal Packing	1	1	1	1
017	Rubber Bushing	1	1	1	1
018	Reinforcement Plate	1	1	1	1
131	Flue Outlet	1	1	1	1
132	Packing	1	1	1	1
133	Packing	2	2	2	2
800	Screw	4	4	4	4
801	Washer	4	4	4	4
802	Screw	2	2	2	2
803	Washer	7	7	7	7
804	Screw	10	10	10	10
805	Screw	8	8	8	8

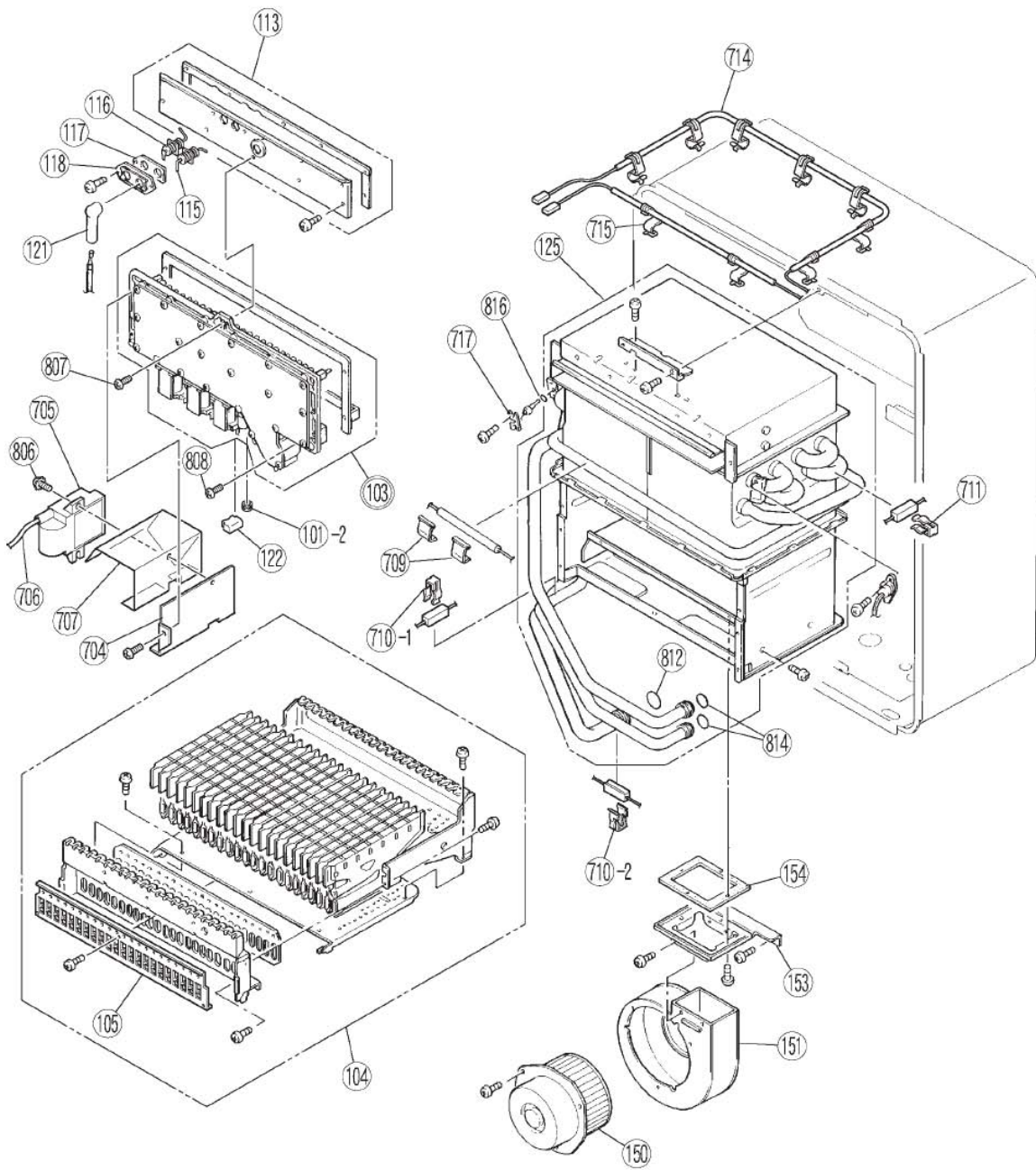

No	Description	TG-237E-N	TG-237E-X	TG-237E-NA	TG-237E-XA
		Quantity			
101	Screw	2	2	2	2
103	Manifold Assembly (LPG)	-	1	-	1
103	Manifold Assembly (NG)	1	-	1	-
104	Burner Unit Assembly (LPG)	-	1	-	1
105	Burner Unit Assembly (NG)	1	-	1	-
113	Combustion Chamber Front Plate	1	1	1	1
115	Electrode	1	1	1	1
116	Flame Rod	1	1	1	1
117	Electrode Packing	1	1	1	1
118	Electrode Holder	1	1	1	1
121	Electrode Sleeve	1	1	1	1
122	Solenoid Valve Cover	1	1	1	1
125	Heat Exchanger Complete Assembly	1	1	-	-
125	Heat Exchanger Complete Assembly	-	-	1	1
150	Blower Motor	1	1	1	1
151	Fan Casing Assembly	1	1	1	1
153	Fan Connecting Bracket	1	1	1	1
154	Fan Connecting Packing	1	1	1	1
704	Igniter Bracket	1	1	1	1
705	Igniter	1	1	1	1
706	High Tension Code	1	1	1	1
707	Igniter Cover	1	1	1	1
709	Anti-Frost Heater Clip	2	2	2	2
710	Anti-Frost Heater Clip	2	2	2	2
711	Anti-Frost Heater Clip	1	1	1	1
714	Thermal Fuse Harness	1	1	1	1
715	Thermal Fuse Clip	9	9	9	9
717	Thermistor Clip	1	1	1	1
806	Screw	1	1	1	1
807	Screw	5	5	5	5
808	Screw	2	2	2	2
812	O-ring	3	3	3	3
814	O-ring	2	2	2	2
816	O-ring	2	2	2	2

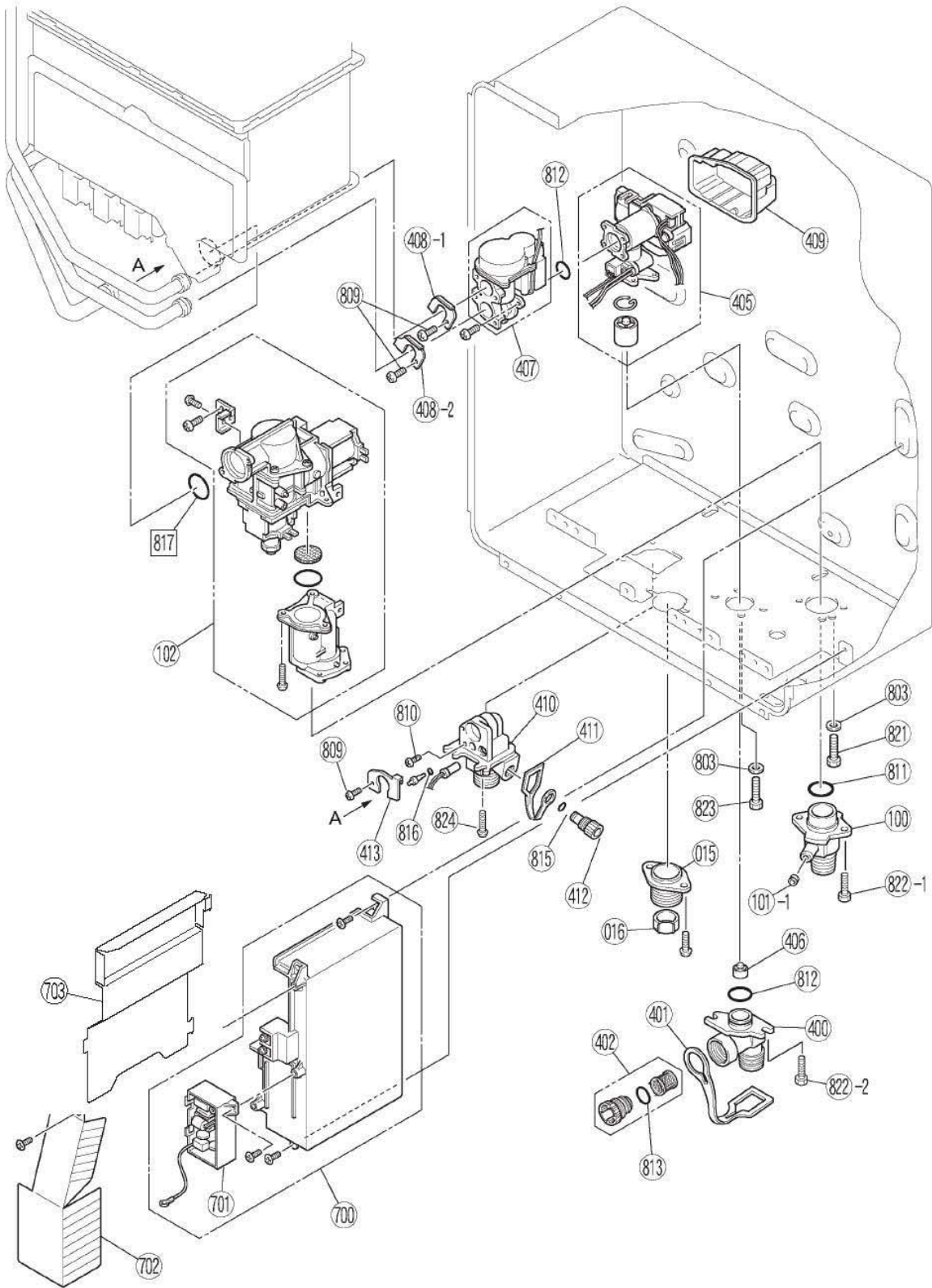

No	Description	TG-237E-N	TG-237E-X	TG-237E-NA	TG-237E-XA
		Quantity			
015	Cable Access	1	1	1	1
016	Cable Access Packing	1	1	1	1
100	Gas Connection	1	1	1	1
101	Screw	2	2	2	2
102	Gas Control Assembly	1	1	1	1
400	Water Inlet	1	1	1	1
401	Plug Band	1	1	1	1
402	Water Filter Assembly	1	1	1	1
405	Water Flow Servo & Sensor Assembly	1	1	1	1
406	Rectifier	1	1	1	1
407	Bypass-Servo Assembly	1	1	1	1
408	Stop Bracket	2	2	2	2
409	Water Flow Servo Cover	1	1	1	1
410	Hot Water Outlet	1	1	1	1
411	Plug Band	1	1	1	1
412	Drain Valve	1	1	1	1
413	Stop Bracket	1	1	1	1
700	Printed Circuit Board	1	1	1	1
701	Surge Protector	1	1	1	1
702	Printed Circuit Board Cover-Front	1	1	1	1
703	Printed Circuit Board Cover-Side	1	1	1	1
803	Washer	7	7	7	7
809	Screw	3	3	3	3
810	Screw	1	1	1	1
811	O-ring	1	1	1	1
812	O-ring	3	3	3	3
813	O-ring	1	1	1	1
815	O-ring	1	1	1	1
816	O-ring	2	2	2	2
817	Packing	1	1	1	1
821	Screw	1	1	1	1
822	Screw	4	4	4	4
823	Screw	2	2	2	2
824	Screw	3	3	3	3

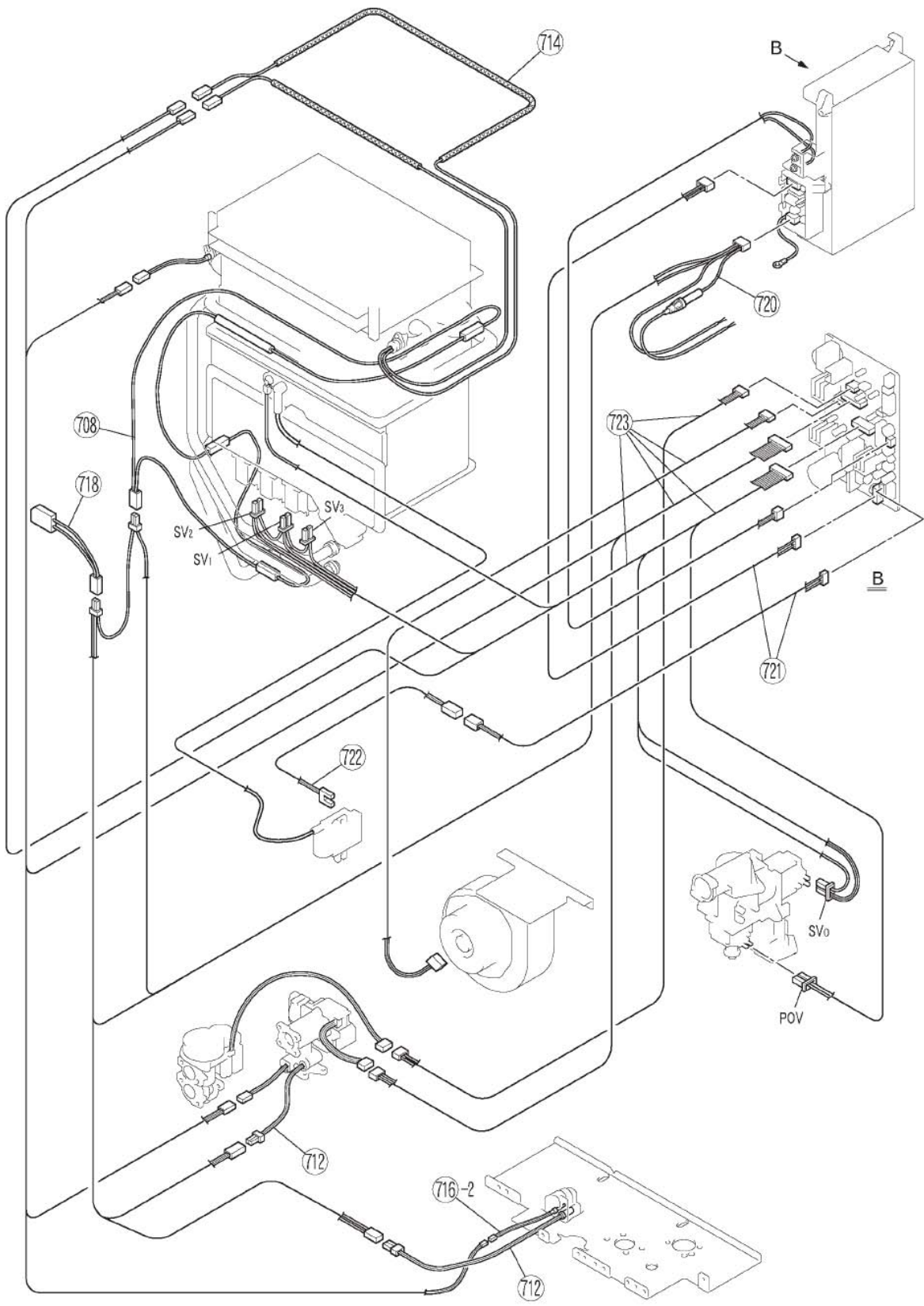

No	Description	Quantity			
		TG-237E-N	TG-237E-X	TG-237E-NA	TG-237E-XA
708	120V Anti-Frost Heater Assembly	1	1	1	1
712	120V Valve Heater Assembly	1	1	1	1
714	Thermal Fuse Harness	1	1	1	1
716	Thermistor	2	2	2	2
718	Frost Sensing Switch	1	1	1	1
720	Fuse Harness	1	1	1	1
721	Power Supply Harness	1	1	1	1
722	Igniter Harness	1	1	1	1
723	Sensor Harness	1	1	1	1

SECTION X: WARRANTY

What does this Limited Warranty Cover?

This limited warranty covers both the heat exchanger and component parts for leakage or other malfunction caused by defects in materials and/or workmanship. It applies to the original consumer purchaser and to any subsequent owner as long as the water heater remains installed at its original place of installation.

What does this limited warranty not cover?

This limited warranty does not cover leakage or other malfunction caused by:

- a) Defective installation, reinstallation at another location and specifically, any installation which is made in violation of applicable state or local plumbing, housing or building codes, or without a certified American Gas Association, ASME, or comparable combination temperature and pressure relief valve, or contrary to the written instructions furnished with the unit.
- b) Adverse local conditions, and specifically sediment or lime precipitate in the heat exchanger; corrosive elements in the atmosphere; or water quality contrary to the written requirements furnished with the unit.
- c) Misuse, and specifically operations and/or maintenance contrary to the written instructions furnished with the unit, removal of anode(s), disconnection, alteration or addition on non-approved components or apparatus, operation at settings other than those set forth on the rating plate, or accidental or other exterior damage.

This warranty also does not cover:

- a) Production of noise, taste, odors, discoloration or rusty water.
- b) Incidental property damage, loss of use, inconvenience or other incidental or consequential costs.
- c) Costs associated with the replacement and/or repair of the unit, including any freight, shipping or delivery charges, any removal, installation or re-installation charges, any material, and/or permits required for installation, re-installation or repair, or charges to return the defective heater and/or component part to the manufacturer.

What is the duration of the implied warranty?

Any implied warranties, including the warranty of merchantability imposed on the sale of the water heater under the laws of the state of sale are limited in duration to one year from date of original installation.

How does state law relate to the warranty?

Some states do not allow:

- a) Limitations on how long an implied warranty lasts.
- b) Limitations on incidental or consequential damages.

So the above limitations or exclusions may not apply to you.

This warranty gives you specific legal rights, and you may also have other rights which vary from state to state.

What is the period of coverage?

This limited warranty runs from the date of installation (or without proof of installation, from three (3) months after the date of manufacture) for the period specified on the following chart.

Item	Residential Applications	Commercial and Radiant Heating Applications
Heat Exchanger	12-years*	5-years*
All other Parts and Components	5-years*	5-years*

A warranty product or part is provided exclusive of labor, freight, and/or any installation costs. All replacement heaters and parts carry the balance of the original warranty, i.e. if an original twelve (12) year warranted heater develops a leak due to defects in materials/workmanship after only ten (10) years, the replacement unit is warranted for two (2) years in this example.

*Note: Period of coverage is reduced to 3-years from date of purchase when used as a circulating water heater within a hot water circulation loop, where the water heater is in series with a circulation system and all circulating water flows through the water heater, and where an on-demand recirculation system is not incorporated.

On-demand re-circulation is defined as a hot water re-circulating loop or system that utilizes existing hot and cold lines or a dedicated return line, and only activates when hot water is used. It can be activated by a push button, motion sensor, or voice activation but not by a temperature sensor. A timer added to a standard re-circulating pump is not considered as on-demand.

Use of a Main Controller/Commercial control (p/n 239-47805-00) in a residential dwelling will reduce the warranty coverage to that of a commercial warranty application.

What will we do to correct problems?

If a defect occurs within the heat exchanger warranty period, we will:

- a) Provide a replacement water heater of our manufacture, (or at our option) repair any unit which develops a leak in the heat exchanger with the warranty period. To obtain a replacement water heater, you must forward both the rating plate from the defective unit to us and a copy of the original sales receipt. If government regulations require the replacement heater to have features not found in the defective heater, you will be required to pay the difference in price represented by those government required features.

If a defect occurs within the parts warranty period, we will:

- a) Provide a replacement part (or at our option repair) any part which fails to function within the parts warranty period. To obtain a replacement, you must forward the defective part to us. If government regulations require the replacement part to have features not found in the defective part, you will be required to pay the difference in price represented by those government required features.

What will we not do?

We will not:

- a) Repair or replace any water heater, or part, subject to conditions outlined in "What does this limited warranty not cover?"
- b) Reimburse any costs associated with repair and/or replacement.
- c) Replace and/or repair any heater without complete model/serial number.
- d) Replace any water heater without prior receipt of actual rating plate from appliance and copy of original sales receipt.

How do you get warranty assistance?

Upon discovering a defect or problem, you should

- a) Contact either the installer or dealer, or
- b) Contact us

Bradford White Corporation
Warranty Support Group
200 Lafayette Street
Middleville, Mi 49333
1-800-531-2111

What should you do to keep the warranty in effect?

To facilitate warranty assistance, you should:

- a) Follow all instructions enclosed with the product.
- b) Retain all bills of sale or receipts for proof of installation, etc.
- c) Contact your installer, dealer or our Warranty Department as soon as any problem or defect is noticed.
- d) When necessary, allow us, or our chosen representative, to inspect the unit.

EverHot® Limited Warranty Registration

In order to confirm Limited Warranty coverage at 12 years for Residential Applications¹, complete the information below and click submit.

*Consumers First Name:

*Consumers Last Name:

*Address:

*City:

*State:

*Zip:

*Phone Number:

*Installation Date:

*Installation Application Type:
(Ex: Residential or Commercial)

*Purchase Date:

*Model Number:

*Serial Number:

*Installation Company:
(Ex: ABC Plumbing Company)

Installer's EverHot® Certification Number:
(Ex: 109456)

Installer's Phone Number:

*Denotes required fields

(1) Period of coverage is reduced to the Commercial Applications Limited Warranty (see above box) if above information is not received by Bradford White Corporation.

Fax Number: Warranty Support Group: 269-795-1089

Online Warranty Registration: www.bradfordwhite.com (check your warranty link)

Mail: Warranty Support Group: 200 Lafayette Street, Middleville, MI 49333-9493

NOTES:

NOTES:



Ambler, PA

For U.S. and Canada field service,
Contact your professional installer or
local Bradford White representative.

Sales/**800-523-2931**

Fax/215-641-1670

Parts Fax/215-641-2180

Technical Support/**800-334-3393**

Fax/269-795-1089

Warranty/**800-531-2111**

Fax/269-795-1089

International:

Telephone/**215-641-9400**

Telefax/215-641-9750



Mississauga, ON

Sales/**866-690-0961**

905-238-0100

Fax/905-238-0105

Technical Support/**800-334-3393**

Email

parts@bradfordwhite.com

techserv@bradfordwhite.com

www.bradfordwhite.com