



See the possibilities

User's Manual

BM-141GE

BB-141GE

*Digital Monochrome / Color
Progressive Scan GigE Vision Camera*

Document Version: Ver.2.1
BMB-141GE_Ver.2.1_Dec2011

Notice

The material contained in this manual consists of information that is proprietary to JAI Ltd., Japan and may only be used by the purchasers of the product. JAI Ltd., Japan makes no warranty for the use of its product and assumes no responsibility for any errors which may appear or for damages resulting from the use of the information contained herein. JAI Ltd., Japan reserves the right to make changes without notice.

Company and product names mentioned in this manual are trademarks or registered trademarks of their respective owners.

Warranty

For information about the warranty, please contact your factory representative.

Certifications

CE compliance

As defined by the Directive 2004/108/EC of the European Parliament and of the Council, EMC (Electromagnetic compatibility), JAI Ltd., Japan declares that BM-141GE and BB-141GE comply with the following provisions applying to its standards.

EN 61000-6-3 (Generic emission standard part 1)

EN 61000-6-2 (Generic immunity standard part 1)

FCC

This equipment has been tested and found to comply with the limits for a Class B digital device, pursuant to Part 15 of the FCC Rules. These limits are designed to provide reasonable protection against harmful interference in a residential installation. This equipment generates, uses and can radiate radio frequency energy and, if not installed and used in accordance with the instructions, may cause harmful interference to radio communications. However, there is no guarantee that interference will not occur in a particular installation. If this equipment does cause harmful interference to radio or television reception, which can be determined by turning the equipment off and on, the user is encouraged to try to correct the interference by one or more of the following measures:

- Reorient or relocate the receiving antenna.
- Increase the separation between the equipment and receiver.
- Connect the equipment into a outlet on a circuit different from that to which the receiver is connected.
- Consult the dealer or an experienced radio/TV technician for help.

Warning

Changes or modifications to this unit not expressly approved by the party responsible for FCC compliance could void the user's authority to operate the equipment.

Supplement

The following statement is related to the regulation on “ Measures for the Administration of the control of Pollution by Electronic Information Products ” , known as “ China RoHS ” . The table shows contained Hazardous Substances in this camera.

 mark shows that the environment-friendly use period of contained Hazardous Substances is 15 years.

重要注意事项

有毒，有害物质或元素名称及含量表

根据中华人民共和国信息产业部『电子信息产品污染控制管理办法』，本产品《有毒，有害物质或元素名称及含量表》如下。

部件名称	有毒有害物质或元素					
	铅 (Pb)	汞 (Hg)	镉 (Cd)	六价铬 (Cr(VI))	多溴联苯 (PPB)	多溴二苯醚 (PBDE)
螺丝固定座	×	○	○	○	○	○
连接插头	×	○	○	○	○	○
电路板	×	○	○	○	○	○
.....

○：表示该有毒有害物质在该部件所有均质材料中的含量均在SJ/T11363-2006规定的限量要求以下。
 ×：表示该有毒有害物质至少在该部件的某一均质材料中的含量超出SJ/T11363-2006规定的限量要求。
 (企业可在此处、根据实际情况对上表中打“×”的技术原因进行进一步说明。)



环保使用期限

电子信息产品中含有的有毒有害物质或元素在正常使用的条件下不会发生外泄或突变、电子信息产品用户使用该电子信息产品不会对环境造成严重污染或对基人身、财产造成严重损害的期限。

数字「15」为期限15年。

Supplement

The following statement is related to the regulation on “ Measures for the Administration of the control of Pollution by Electronic Information Products ” , known as “ China RoHS ” . The table shows contained Hazardous Substances in this camera.

 mark shows that the environment-friendly use period of contained Hazardous Substances is 15 years.

重要注意事项

有毒，有害物质或元素名称及含量表

根据中华人民共和国信息产业部『电子信息产品污染控制管理办法』，本产品《有毒，有害物质或元素名称及含量表》如下。

部件名称	有毒有害物质或元素					
	铅 (Pb)	汞 (Hg)	镉 (Cd)	六价铬 (Cr(VI))	多溴联苯 (PPB)	多溴二苯醚 (PBDE)
螺丝固定座	×	○	○	○	○	○
光学滤色镜	×	○	×	○	○	○
连接插头	×	○	○	○	○	○
电路板	×	○	○	○	○	○
.....

○：表示该有毒有害物质在该部件所有均质材料中的含量均在SJ/T11363-2006规定的限量要求以下。
 ×：表示该有毒有害物质至少在该部件的某一均质材料中的含量超出SJ/T11363-2006规定的限量要求。
 (企业可在此处、根据实际情况对上表中打“×”的技术原因进行进一步说明。)



环保使用期限

电子信息产品中含有的有毒有害物质或元素在正常使用的条件下不会发生外泄或突变、电子信息产品用户使用该电子信息产品不会对环境造成严重污染或对基人身、财产造成严重损害的期限。

数字「15」为期限15年。

BM-141GE / BB-141GE

Table of Contents

JAI GigE® Vision Camera operation manuals	6
Introduction	6
Before using GigE Vision cameras.....	6
Software installation	6
Camera Operation	7
1. General	7
2. Camera nomenclature	7
3. Main Features	8
4. Locations and Functions	9
4.1. Locations and functions.....	9
4.2. Rear panel indicator.	10
4.3. Flange back adjustment	10
5. Pin Assignment.....	11
5.1 12-pin Multi-connector (DC-in/GPIO/Iris Video).....	11
5.2 Digital Output Connector for Gigabit Ethernet	11
5.3 D-sub 9 pin connector for GPIO (Auxiliary)	12
5.4 Internal DIP switch.....	12
6. GPIO (Inputs and outputs)	13
6.1. Overview.....	13
5.4.1 LUT (Cross Point Switch)	14
5.4.2 12-bit Counter.....	14
5.4.3 Pulse Generators (0 to 1).....	14
5.5 Opto-isolated Inputs/Outputs.....	15
5.5.1 Recommended External Input circuit diagram for customer.....	15
5.5.2 Recommended External Output circuit diagram for customer	16
5.5.3 Optical Interface Specifications.....	16
6.3. Inputs and outputs table.....	17
6.4. Configuring the GPIO module	17
6.4.1 Input /Output Signal Selector	17
6.4.2 GPIO Plus PWC shutter.....	19
6.4.3 Internal Trigger Generator.....	20
7. Image output	21
7.1. CCD Sensor Layout.....	21
7.2. Vertical Binning (BM-141GE only).....	21
7.3. Partial Scanning (Fixed rate and variable)	22
7.4. Digital video output	23
7.4.1 Digital Video Output (Bit Allocation)	23
7.4.2 Bit Allocation (Pixel Format / Pixel Type) - BM-141GE (monochrome)	24
7.4.3 Bit Allocation (Pixel Format / Pixel Type) - BB-141GE (Bayer mosaic color)	25
7.5. BB-141GE. Bayer mosaic filter	27
7.6. Image timing	28
7.6.1 Horizontal timing.....	28
7.6.2 Vertical timing	28
7.6.3 Partial Scanning	29
7.6.4 Vertical binning.....	30
7.7. Auto-Iris Lens video output (12-pin Hirose connector)	31
8. Network configuration	32
8.1. GigE Vision Standard Interface	32
8.2. Equipment to configure the network system	32
8.2.1 PC	32
8.2.2 Cables	32
8.2.3 Network card (NIC).....	32
8.2.4 Hub.....	33
8.3. Recommended Network Configurations	33

8.3.1	Guideline for network settings.....	33
8.2.2	Video data rate (network bandwidth)	34
8.3.3	Note for setting packet size	34
8.3.5	Simplified calculation (Approximate value)	35
8.3.6	Note for 100BASE-TX connection	36
8.4.	GigE camera connecting examples	36
8.4.1	Using a switching hub for 1 port	36
8.4.2	Connecting a camera to each port of a multi-port NIC.....	37
8.4.3	The data transfer for multiple cameras.....	37
9.	Basic functions.....	39
9.1.	Electronic Shutter	39
9.2.	Full Auto Exposure function	40
9.3.	Pre-process functions.....	41
9.3.1	Bayer White Balance (BB-141GE only)	41
9.3.2	Automatic Gain Control	41
9.3.3	Programmable Look UP table (LUT).....	42
10.	Operation mode	44
10.1.	The functions related to GenICam SFNC 1.3	44
10.2	GenICam SFNC Standard Trigger Setup Wizard	46
10.3.	Operation Modes	47
10.3.1	Continuous operation	47
10.3.2	Edge Pre-select (EPS) Trigger Mode	48
10.3.3	Pulse Width Control (PWC) Trigger Mode.....	50
10.3.4	Auto-detect LVAL-sync / a-sync. accumulation	52
10.3.5	Reset Continuous (RCT) trigger mode	52
10.3.6	Sequential Trigger Mode (EPS).....	54
10.3.7	Delayed Readout EPS and PWC Modes (EPS and PWC)	55
10.3.8	Optical Black transfer Mode	57
10.3.9	Multi ROI mode (Multi Region of Interest).....	58
10.4.	Operation Mode and Functions matrix	58
11.	JAI control tool.....	59
11.1.	About GenICam™SFNC1.3	59
11.2.	JAI SDK Ver.1.3.....	59
11.3.	Examples of camera operation	60
11.3.1	Generic cautions for operation	60
11.3.2	Connection of camera(s)	60
11.3.3	Camera setting level	60
11.4.	Input and Output settings	60
11.4.1	Interfacing with external devices.....	60
11.4.2	Setting of input and output	61
11.4.3	Setting the image size	62
11.4.4	Acquisition of the image.....	62
11.4.5	How to look at XML file	63
11.4.6	Feature Tree Information	63
11.4.7	Feature Properties (Guru).....	64
12.	External Appearance and Dimensions.....	68
13.	Specifications.....	69
13.1.	Spectral response	69
13.2.	Specification table.....	70
Appendix	72
	Precautions.....	72
	Typical Sensor Characteristics.....	72
	Caution when mounting the camera.....	73
	Exportation.....	73
	References	73

BM-141GE / BB-141GE

Change History74
User's Record75

JAI GigE[®] Vision Camera operation manuals

To understand and operate this JAI GigE[®] Vision camera properly, JAI provides the following manuals.

User's manual (this booklet)	Describes functions and operation of the hardware
JAI SDK & Control Tool User Guide	Describes functions and operation of the Control Tool
JAI SDK Getting Started Guide	Describes the network interface

User's manual is available at www.jai.com

JAI SDK & Control Tool User Guide and JAI SDK Getting Started Guide are provided with the JAI SDK which is available at www.jai.com.

Introduction

GigE Vision is a standard interface which uses Gigabit Ethernet for machine vision applications. It was developed primarily by AIA (Automated Imaging Association) members. GigE Vision is capable of transmitting large amounts of uncompressed image data through an inexpensive general purpose LAN cable over long distances.

GigE Vision also supports the GenICam[™] standard which is maintained by the EMVA (European Machine Vision Association). The purpose of the GenICam standard is to provide a common program interface for various machine vision cameras. By using GenICam, cameras from different manufactures can seamlessly connect in one platform.

For details about the GigE Vision standard, please visit the AIA web site, www.machinevisiononline.org and for GenICam, the EMVA web site, www.genicam.org.

JAI GigE Vision cameras comply with both the GigE Vision standard and the GenICam standard.

Before using GigE Vision cameras

All software products described in this manual pertain to the proper use of JAI GigE Vision cameras. Product names mentioned in this manual are used only for the explanation of operation. Registered trademarks or trademarks belong to their manufacturers. To use the JAI SDK, it is necessary to accept the "Software license agreement" first.

This manual describes necessary equipment and the details of camera functions.

Software installation

The JAI GigE Vision SDK & Control Tool can be downloaded from the JAI web site at www.jai.com. The JAI SDK is available for Windows XP and Vista, 32-bit and 64-bit. For the details of software installation, please refer to the "Getting Started Guide" supplied on the JAI SDK download page.

Camera Operation

1. General

This manual covers the digital monochrome progressive scan camera BM-141GE and color progressive scan camera BB-141GE

BM-141GE/BB-141GE is a GigE Vision compliant camera, belonging to the C3 Basic family. Both the monochrome version BM-141GE and the color version BB-141GE provide a frame rate of 30 frames/second at full resolution. Using vertical binning (BM-141GE only), or partial scan, the camera can achieve faster frame rates.

The 2/3" CCD with square pixels offers a superb image quality. The high-speed shutter function and asynchronous random trigger mode allows the camera to capture high quality images of fast moving objects.

The color version BB-141GE, based on CCD sensor with primary RGB Bayer mosaic filter, outputs raw Bayer images. The JAI Camera Control Tool included in JAI SDK provides color interpolation to display or save color images. The camera features a built-in white balance, eliminating the need for performing this function in the host-PC.

The BM-141GE/BB-141GE also complies with the GenICam standards, as it has an internal XML file that is used to describe the functions/features of the camera. For further information on GenICam please go to www.emva.org

As an application programming interface, JAI provides an SDK (Software Development Kit). This SDK includes GigE Vision Filter Driver, JAI Control tool, software documentation and code examples.

The JAI SDK can be downloaded from www.jai.com.

The latest version of this manual can be downloaded from www.jai.com

For camera revision history, please contact your local JAI distributor.

2. Camera nomenclature

The standard camera composition consists of the camera main body and C-mount protection cap.

The camera is available in the following versions:

BM-141GE

Where **B** stands for "Basic" family, **M** stands for "Monochrome", **141** represents the resolution "1.4 million pixel", **141** represents variation with the same resolution and **GE** stands for "GigE Vision" interface.

BB-141GE

Where **B** stands for "Basic" family, **B** stands for "Bayer mosaic color", **141** represents the resolution "1.4 million pixel", **141** represents variation with the same resolution and **GE** stands for "GigE Vision" interface.

3. Main Features

- Member of C3 Basic camera series
- GigE vision and GenICam compliant
- 1392 (h) x 1040 (v) 6.45 μm square pixels
- 2/3 inch progressive scan - Monochrome and Bayer mosaic color versions
- 30.12 frames/second with full resolution in continuous operation
- 30 frames/second with external trigger and full resolution
- Increased frame rate with vertical binning (BM-141GE only) , and fixed or variable partial scan
- Exposure time from 63 μs to 2 sec. using Pulse Width trigger mode
- Programmable exposure from 63 μs to 33 ms in Full Frame scan
- Preset and auto shutter modes provided
- GPIO in combination with Pulse width trigger for more precise exposure time
- Sequencer trigger mode for on-the -fly change of gain, exposure and ROI
- Edge Pre-select, Pulse width control and Reset Continuous trigger modes
- One-push, preset, manual or auto Bayer white balance for BB-141GE
- Manual and automatic gain control
- Look Up Table (LUT) for gamma and knee settings
- LVAL-synchronous/ -asynchronous operation (auto-detect)
- Auto iris lens video output allows a wider range of light (Can be Selected by DIP switch)
- Full Auto Exposure mode combining auto gain, auto shutter, and auto iris functions
- GigE Vision Interface with 12, 10 or 8-bit output
- Programmable GPIO with opto-isolated inputs and outputs
- Flange back adjustment mechanism provided
- Comprehensive software tools and SDK for Windows XP/Vista (32 bit(x86) and 64 bit(x64) (JAI SDK Ver. 1.2.1 and after)

4. Locations and Functions

4.1. Locations and functions

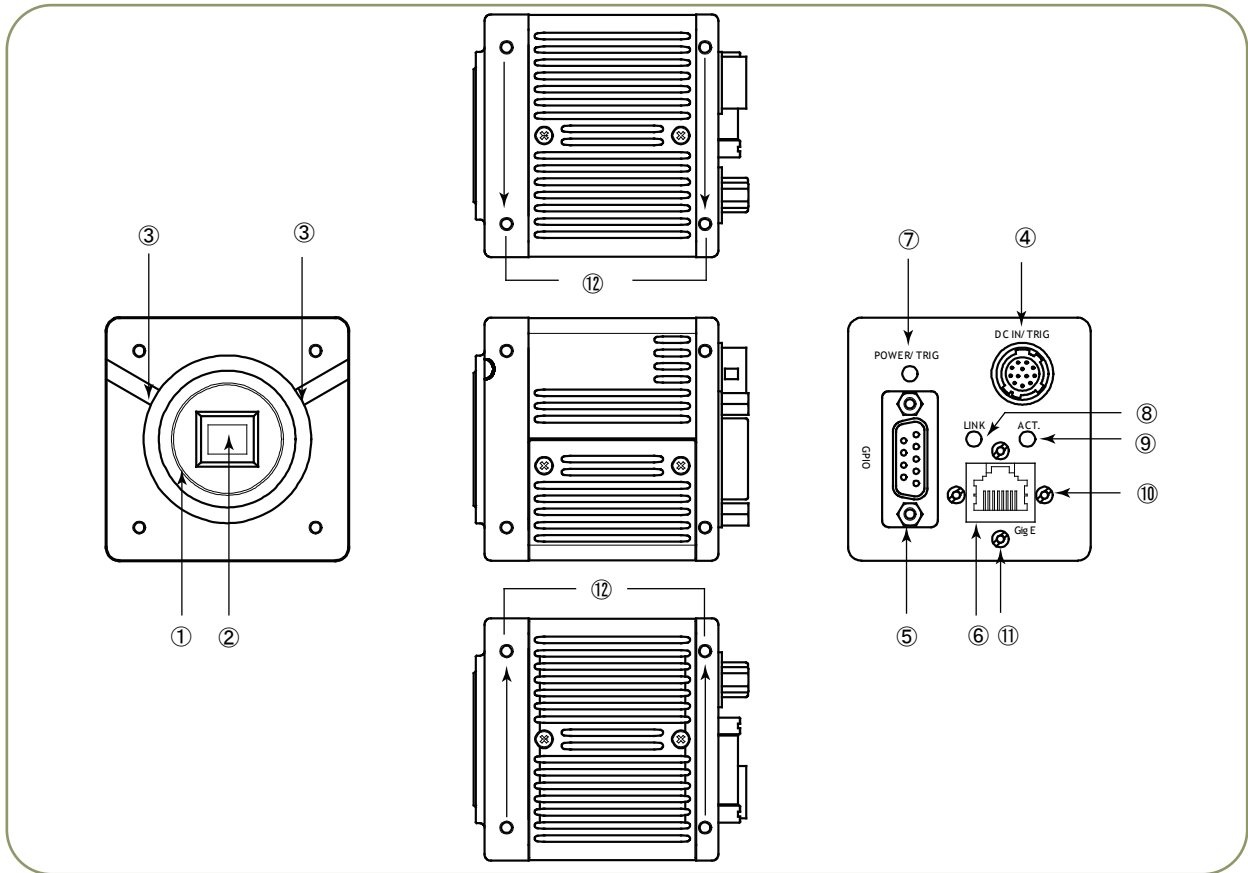

1. Lens mount
2. CCD sensor
3. Flange back fixed screws
4. 12-pin connector
5. D-sub 9 pin connector
6. RJ-45
7. LED
8. LED
9. LED
10. Holes for RJ-45 thumbscrews
11. Holes for RJ-45 thumbscrews
12. Mounting holes

- C-mount (Note *1)
 2/3 inch CCD sensor
 Fix the ring after flange back adjustment
 DC +12V power and GPIO interface
 Auxiliary GPIO interface (LVDS IN and TTL IN/OUT)
 GigE Vision I/F. Accepts connector w thumbscrews.
 Indication for power and trigger
 GigE Network condition: LINK
 GigE Network condition: ACT
 Horizontal type (left and right of RJ-45) (Note *2)
 Vertical type (above and below RJ-45). (Note*2)
 M3 depth 5 mm for tripod mount plate (Note *3)

- *1) Note: Rear protrusion on C-mount lens must be less than 10.0mm.
 *2) Note: When an RJ-45 cable with thumbscrews is connected to the camera, please do not excessively tighten screws by using a screwdriver. The RJ-45 receptacle on the camera might be damaged.
 For security, the strength to tighten screws is less than 0.291 Newton meter (Nm). Tightening by hand is sufficient in order to achieve this.
 *3) Note: The tripod adapter plate MP-41 can be used with BM/BB-141GE

Fig. 1. Locations

4.2. Rear panel indicator.

The rear panel mounted LED provides the following information:

Power Trig LED

- Amber: Power connected - initiating
- Steady green: Camera is operating in Continuous mode
- * Flashing green: Camera is receiving an external trigger

LINK LED

- Steady green: 1000 Base-T has been connected
- * Flashing green: 100 Base-TX has been connected

ACT LED

- * Flashing amber: Network active in communication

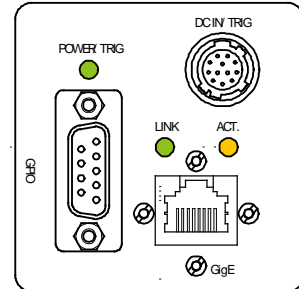

Fig.2 Rear Panel

4.3. Flange back adjustment

Flange back adjustment ring



Flange back fixed screws



BM-141GE / BB-141GE

1. Attach the C mount lens to the camera (①).
2. Under the actual environment and the actual distance to the object, check whether it is possible to focus the lens by rotating the focus ring of the lens.
3. If it does not focus, loosen two flange back fixed screws (③).
4. Set the focus ring indication in accordance with the distance to the object, for instance, 1 m.



5. Under this condition, rotate the lens. As the flange back adjustment ring is rotated simultaneously, set the ring so as to focus the lens. (①).
6. At that position, tighten two flange back fixed screws. (③).

5. Pin Assignment

5.1 12-pin Multi-connector (DC-in/GPIO/Iris Video)

Type: HR10A-10R-12PB
(Hirose) male.
(Seen from the rear of camera)

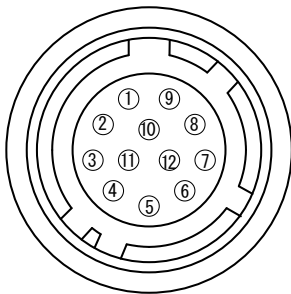

Pin no.	Signal	Remarks
1	GND	
2	+12 V DC input	
3	Opt IN 2 (-) / GND (*1)	GPIO IN / OUT
4	Opt IN 2 (+)/Iris Video out (*1)	
5	Opt IN 1 (-)	
6	Opt IN 1 (+)	
7	Opt Out 1 (-)	
8	Opt Out 1 (+)	
9	Opt Out 2 (-)	
10	Opt Out 2 (+)	
11	+ 12 V DC input	
12	GND	

Fig. 3. 12-pin connector.

*1: Iris Video output function can be set by the internal DIP switch (SW601).

5.2 Digital Output Connector for Gigabit Ethernet

Type: RJ-45 : HFJ11-1G02E-L21RL or equivalent

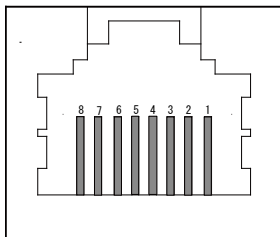

The digital output signals follow the Gigabit Ethernet interface using RJ-45 conforming connector. The following is pin assignment for Gigabit Ethernet connector.

Pin No	In/Out	Name
1	In/Out	MX1+ (DA+)
2	In/Out	MX1- (DA-)
3	In/Out	MX2+ (DB+)
4	In/Out	MX3+ (DC+)
5	In/Out	MX3- (DC-)
6	In/Out	MX2- (DB-)
7	In/Out	MX4+ (DD+)
8	In/Out	MX4- (DD-)

Fig. 4. Gigabit Ethernet connector

5.3 D-sub 9 pin connector for GPIO (Auxiliary)

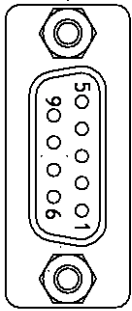

Type: DD-09SSG

No	I/O	Name	Note
1	I	LVDS In1-	
2	I	LVDS In1+	
3	I	TTL IN 1	75ohm Terminator *1
4	O	TTL Out 1	
5		GND	
6		NC	
7		NC	
8	O	TTL Out 2	
9		GND	

Fig. 5 D-sub 9 pin connector

5.4 Internal DIP switch

In order to change, the top cover must be removed.

SW601 For selection of OPT IN and Iris Video OUT

SW600 For selection of TTL IN 1 75 ohm ON or OFF

Factory default is UP position (OPT IN). To select an Iris video, these two switches should be set at DOWN.

Factory default is UP position (75 ohm OFF). To set 75 ohm ON, these two switches must be DOWN.

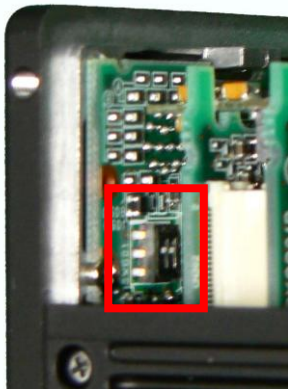

Left side, as seen from the lens side

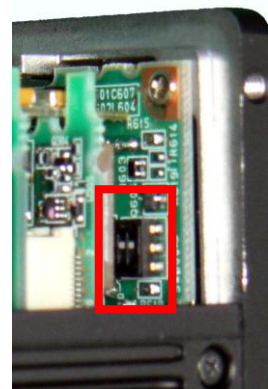

Right side, as seen from the lens side

Fig.6. DIP switch

6. GPIO (Inputs and outputs)

6.1. Overview

All input and output signals pass through the GPIO (General Purpose Input and Output) module. The GPIO module consists of a Look-Up Table (LUT - Cross-Point Switch), 2 Pulse Generators and a 12-bit counter. In the LUT, the relationship between inputs, counters and outputs is governed by internal register set-up.

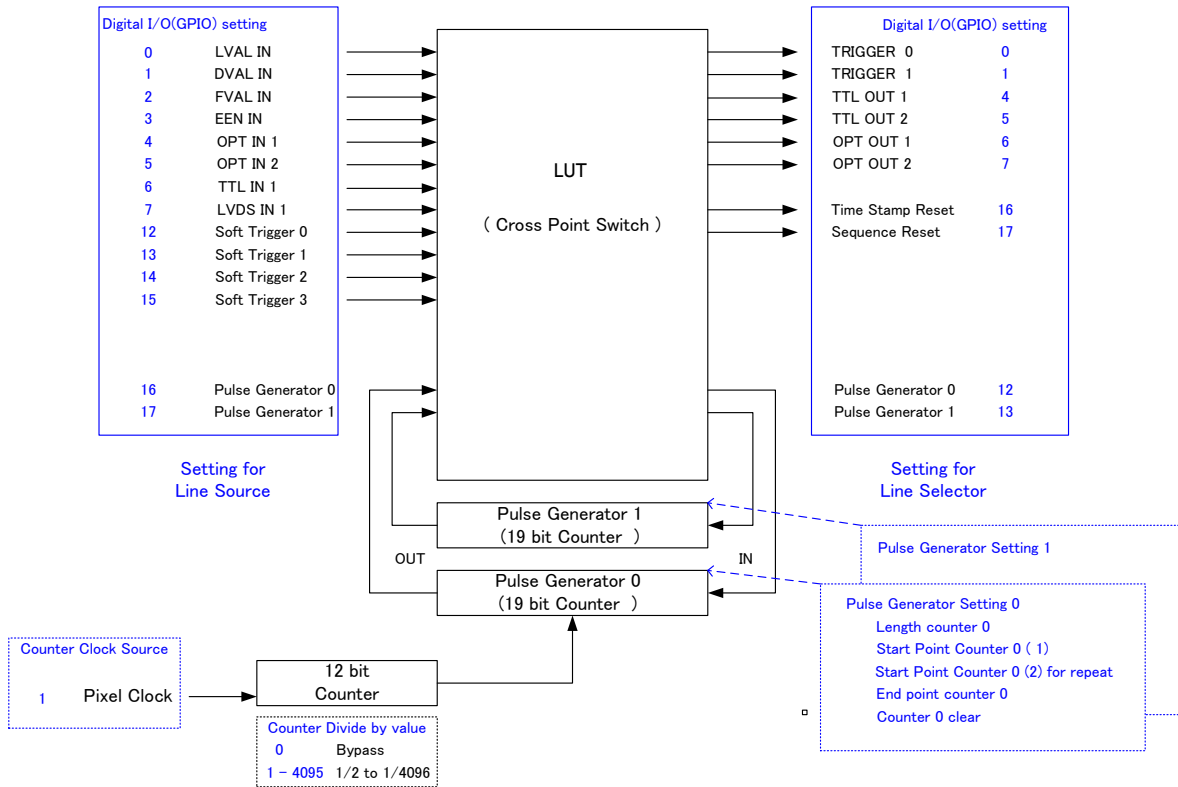

Fig.7 GPIO

In the BM-141GE and BB-141GE, the relation for the external interface is fixed as below.

Line	Signal	Connector
Line 1	TTL Out 1	D Sub 9P pin #4
Line 2	TTL Out 2	D Sub 9P pin #8
Line 3	Optical Out 1	Hirose 12P pin # 7/8
Line 4	Optical Out 2	Hirose 12P pin # 9/10
Line 5	Optical In 1	Hirose 12P pin # 5/6
Line 6	Optical In 2	Hirose 12P pin # 3/4
Line 7	TTL In	D Sub 9P pin #3
Line 8	LVDS In	D Sub 9P pin #1/2

5.4.1 LUT (Cross Point Switch)

The LUT works as a cross-point switch which allows connecting inputs and outputs freely. The signals LVAL_IN, DVAL_IN, FVAL_IN and EEN_IN all originate from the camera timing circuit. On this diagram, Trigger 0 is used for exposure and Trigger 1 is used for Delayed Readout. The Time Stamp Reset signal can reset the time stamp specified in GigE Vision Format. This signal can be used when time stamps from several cameras connected are coincident with each other.

5.4.2 12-bit Counter

The camera pixel clock can be used as a source. The counter has a “Divide by N”, where N has the range 1 through 4096, allowing a wide range of clock frequencies to be programmed. Setting Value 0 is bypass, setting value 1 is 1/2 dividing and setting value 4095 is 1/4096 dividing. The pixel clock for BM-141GE/BB-141GE is 58 MHz.

5.4.3 Pulse Generators (0 to 1)

Each pulse generator consists of a 19-bit counter. The behavior of these signals is defined by their pulse width, start point and end point.

The pulse generator signals can be set in either triggered or periodic mode.

In triggered mode, the pulse is triggered by the rising edge/falling edge/high level or low level of the input signal. In periodic mode, the trigger continuously generates a signal that is based on the configured pulse width, starting point and end point.

Each pulse generator operates at the frequency created in the 12-bit counter. As the pixel clock (58 MHz) is used as the main frequency, the frequency of pulse generator is 58MHz to 31.693 KHz.

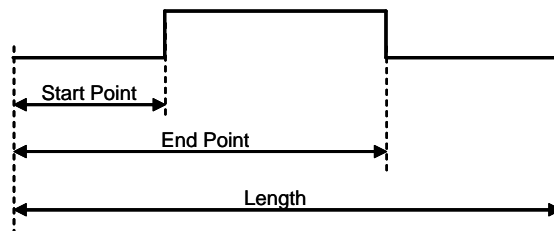

Fig.8 Pulse generated

The following drawing is an example of settings.

FVAL is used for the input of a pulse generator 0 and the clock after the rising edge of FVAL counts 100 clocks for the high period of the pulse and 102 clocks for the pulse length.

As 2400 is for Clock Pre-scaler, the output of 12 bit counter is 25 KHz, which is 40µs.

The pulse generator o creates 4 ms pulse.

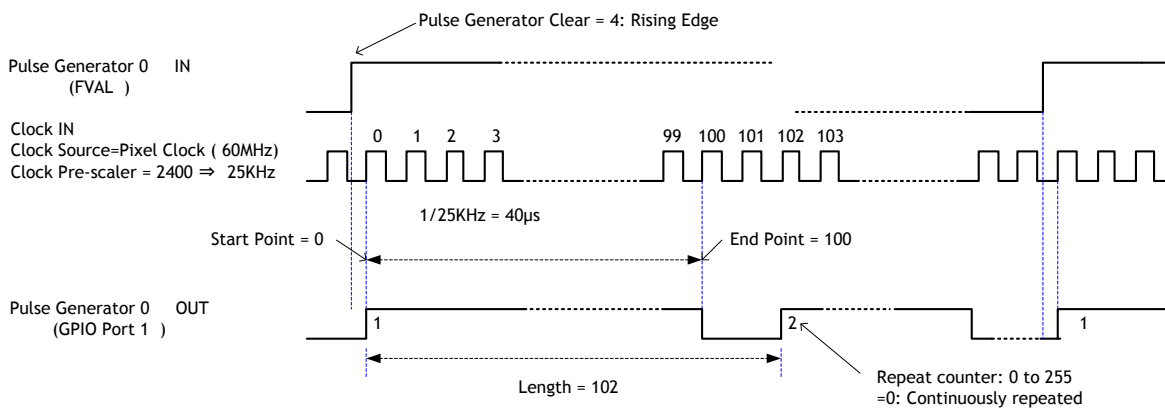

The following shows JAI SDK Camera Control Tool for setting Pulse Generator.

Pulse Generators	
Clock Source	Pixel Clock (60MHz)
Clock Pre-scaler	1
Pulse Generator Clock (MHz)	60.00000
Pulse Generator Selector	Pulse Generator 0
Pulse Generator Length	1
Pulse Generator Length (ms)	0.00002
Pulse Generator Frequency (Hz)	60000000.00000
Pulse Generator Start Point	0
Pulse Generator Start Point (ms)	0.00000
Pulse Generator End Point	1
Pulse Generator End Point (ms)	0.00002
Pulse Generator pulse-width (ms)	1.6666666666666667E-05
Pulse Generator Repeat Count	0
Pulse Generator Clear Activation	Free Run
Pulse Generator Clear Source	Off
Pulse Generator Clear Inverter	False
Clear Mode for the Pulse Generators	Free Run

5.5 Opto-isolated Inputs/Outputs

The control interface of the C3 GigE Vision camera series has opto-isolated inputs and outputs, providing galvanic separation between the camera's inputs/outputs and peripheral equipment. In addition to galvanic separation, the opto-isolated inputs and outputs can cope with a wide range of voltages; the voltage range for inputs is +3.3V to +24V DC whereas outputs will handle +5V to +24V DC.

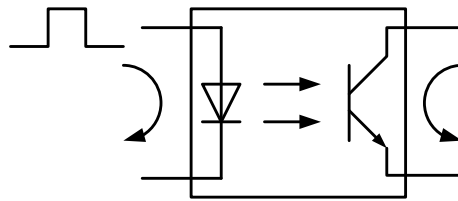

Fig.9. Photo coupler

5.5.1 Recommended External Input circuit diagram for customer

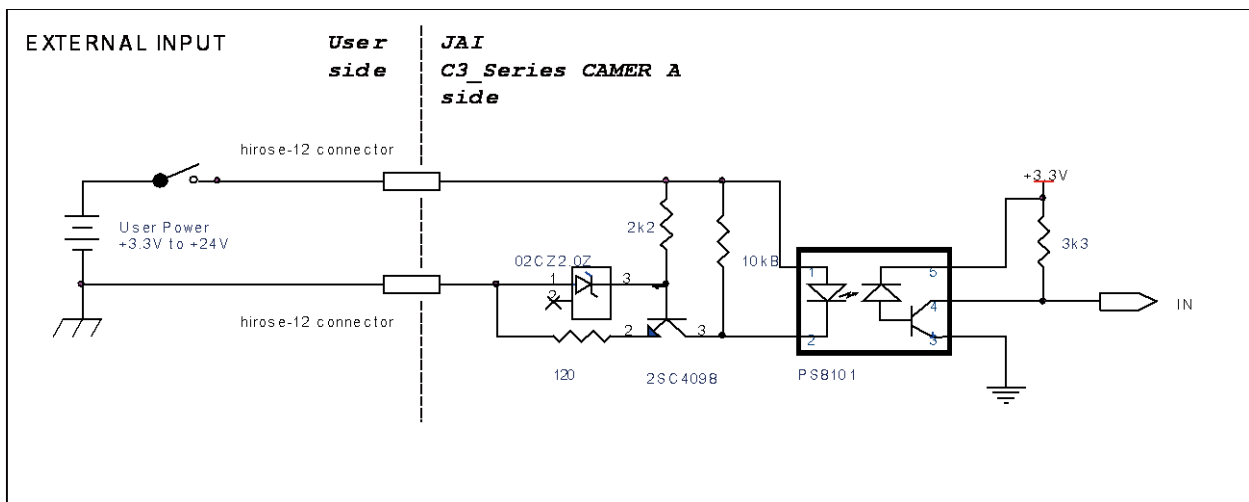

Fig.10. External Input Circuit, OPT IN 1 and 2

5.5.2 Recommended External Output circuit diagram for customer

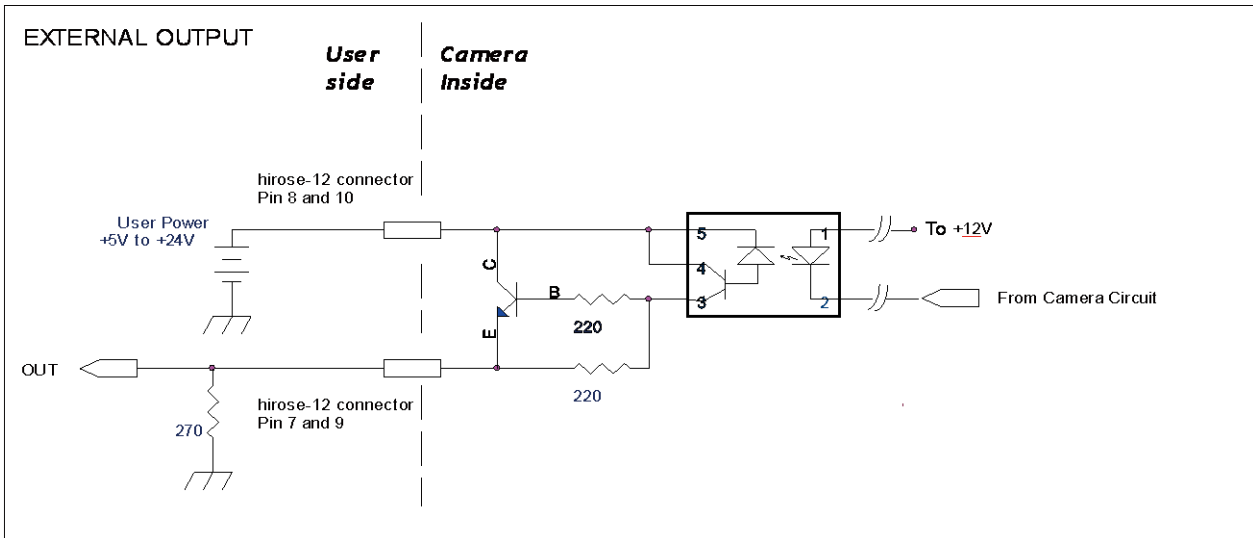

Fig.11. External Output Circuit, OPT OUT 1 and 2

5.5.3 Optical Interface Specifications

The relation of the input signal and the output signal through the optical interface is as follows.

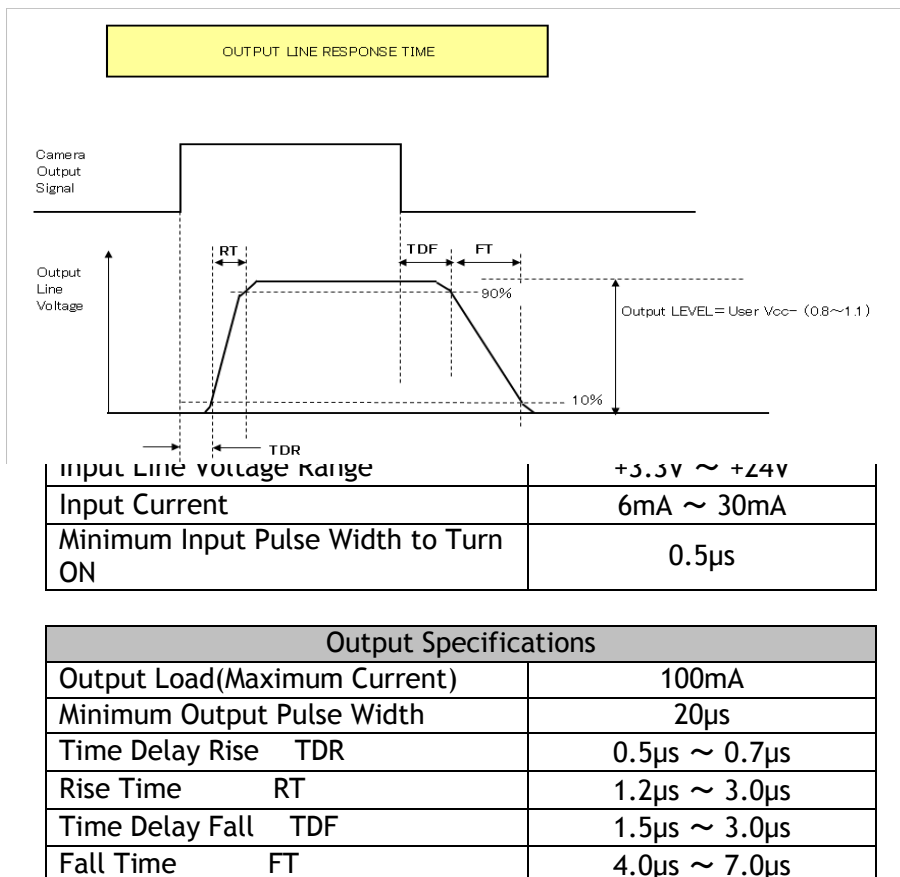

Fig.12 Optical Interface Performance

6.3. Inputs and outputs table

		Output Ports									
		Trigger 0	Trigger 1	OPT OUT1	OPT OUT2	TTL OUT1	TTL OUT2	Time Stamp Reset	Sequence Reset	Pulse Generator 0	Pulse Generator 1
Input Ports	LVAL IN	x	x	x	x	○	○	x	x	○	○
	DVAL IN	x	x	x	x	○	○	x	x	○	○
	FVAL IN	x	x	x	x	○	○	x	x	○	○
	EEN IN	x	x	○	○	○	○	x	x	○	○
	OPT IN 1	○	○	○	○	○	○	○	○	○	○
	OPT IN 2	○	○	○	○	○	○	○	○	○	○
	TTL IN	○	○	○	○	○	○	○	○	○	○
	LVDS IN	○	○	○	○	○	○	○	○	○	○
	Soft Trigger 0	○	○	○	○	○	○	○	○	○	○
	Soft Trigger 1	○	○	○	○	○	○	○	○	○	○
	Soft Trigger 2	○	○	○	○	○	○	○	○	○	○
	Soft Trigger 3	○	○	○	○	○	○	○	○	○	○
	Pulse Gen. 0	○	○	○	○	○	○	○	○	x	○
	Pulse Gen. 1	○	○	○	○	○	○	○	○	○	x

LEGEND: 0 = valid combination / x = Not valid (do not use this combination)
 The shaded parts are for the interface to external equipment.

6.4. Configuring the GPIO module

6.4.1 Input /Output Signal Selector

The following shows JAI SDK Camera Control Tool for setting.

Line Selector

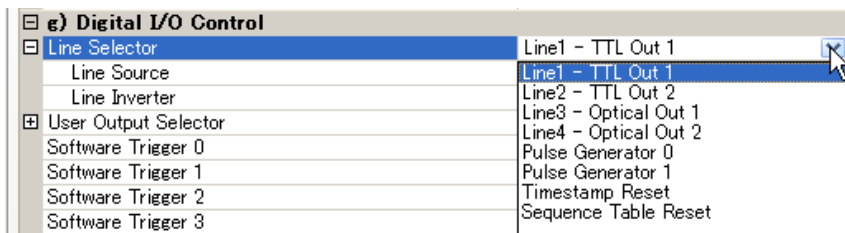

Line Source

g) Digital I/O Control	
Line Selector	Line1 - TTL Out 1
Line Source	LVAL
Line Inverter	Off
User Output Selector	LVAL
Software Trigger 0	DVAL
Software Trigger 1	FVAL
Software Trigger 2	Exposure Active
Software Trigger 3	Line5 - Optical In 1
h) Sequence Control	
Sequence Mode	Line6 - Optical In 2
Sequence Repetition Count	Line7 - TTL In
Last Sequence	Line8 - LVDS In
Sequence Selector	Software Trigger 0
Save Sequence Settings	Software Trigger 1
Reset Sequence Settings	Software Trigger 2 / Action 1
i) Pulse Generators	
	Software Trigger 3 / Action 2
	Pulse Generator 0
	Pulse Generator 1
	Action 1
	Action 2

6.5. GPIO programming examples

6.5.1 Pulse generator setting screen

i) Pulse Generators	
Clock Source	Pixel Clock (58MHz)
Clock Pre-scaler	4096
Pulse Generator Clock (MHz)	0.01416
Pulse Generator Selector	Pulse Generator 0
Pulse Generator Length	1
Pulse Generator Length (ms)	0.07062
Pulse Generator Frequency (Hz)	14160.15625
Pulse Generator Start Point	0
Pulse Generator Start Point (ms)	0.00000
Pulse Generator End Point	1
Pulse Generator End Point (ms)	0.07062
Pulse Generator pulse-width (ms)	0.070620689655172417
Pulse Generator Repeat Count	0
Pulse Generator Clear Activation	Free Run
Pulse Generator Clear Source	Off
Pulse Generator Clear Inverter	False
Clear Mode for the Pulse Generators	Free Run

BM-141GE / BB-141GE

6.4.2 GPIO Plus PWC shutter

Example: 10µs unit pulse width exposure control (PWC).

Pixel clock is 58MHz. 580 clocks (680-100) equal 10µs.

Feature			Value
c)Acquisition and Trigger controls	Trigger selector	Trigger Mode	ON
JAI Acquisition and Trigger Control	JAI Exposure Mode		Pulse width control
Pulse Generators	Pulse Generator selector	Pulse Generator 0 Selector	Line 5 =OPT IN 1
		Clock Choice	1 = Pixel Clock (30MHz)
		Counter Dividing Value	0 = Pass through
		Length Counter 0	1000 Clocks
		Start point Counter 0	100 Clocks
		Repeat Count 0	1
		End point Counter 0	580 Clocks
		Counter Clear 0	Rising Edge
		Trigger source	pulse generator 0

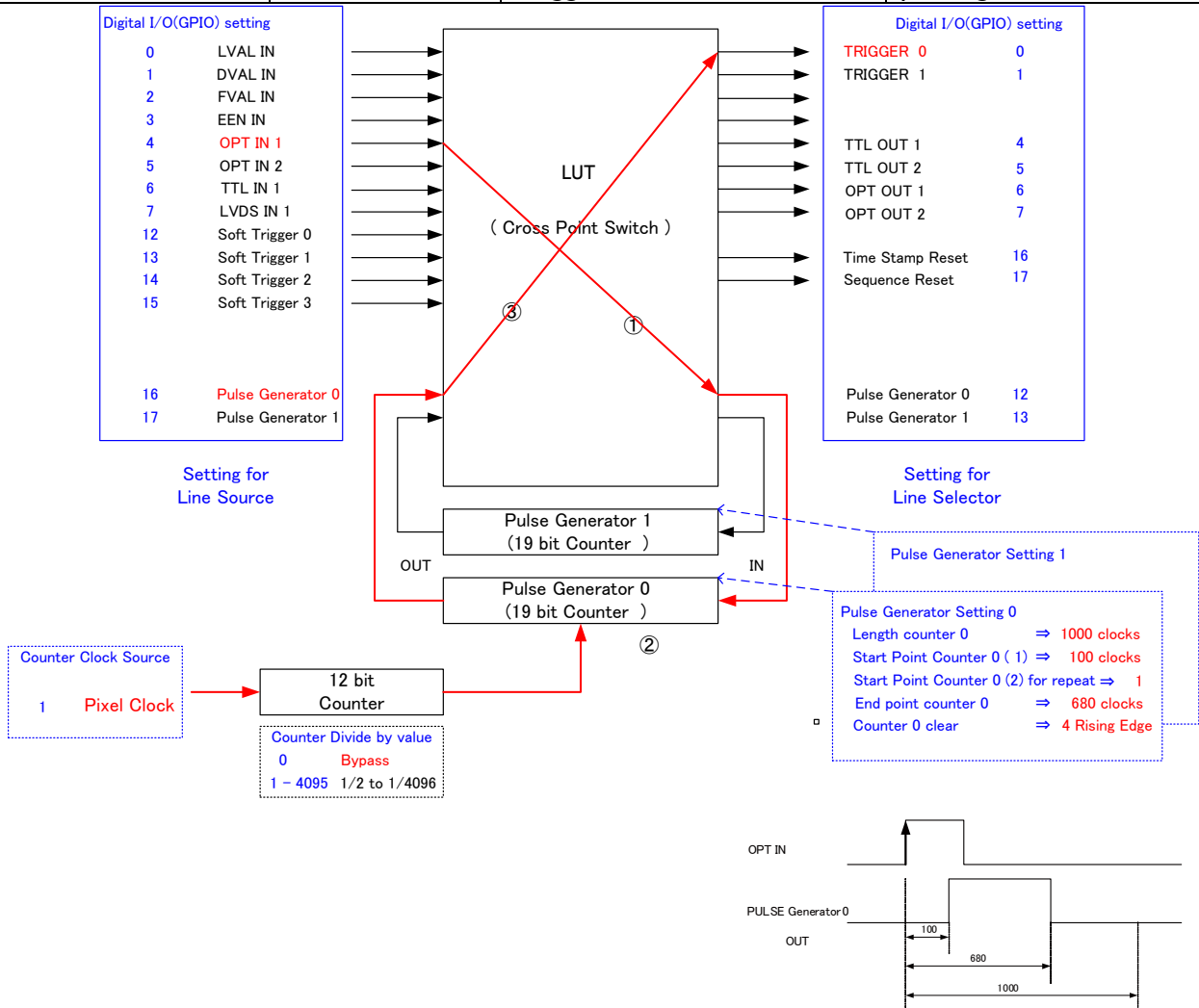

Fig.13 Pulse Generator Timing Example 1

6.4.3 Internal Trigger Generator

Example: Create a trigger signal and trigger the camera

Feature			Value
c)Acquisition and Trigger controls	Trigger selector	Trigger Mode	ON
Pulse Generators	Pulse Generator selector	Pulse Generator 0	
		Clock Choice	1 = Pixel Clock (30MHz)
		Counter Dividing Value	1830(line rate)
		Length Counter 0	1000 Clocks
		Start point Counter 0	100 Clocks
		Repeat Count 0	0
		End point Counter 0	500 Clocks
		Clear activation	Off
		Trigger source	pulse generator 0

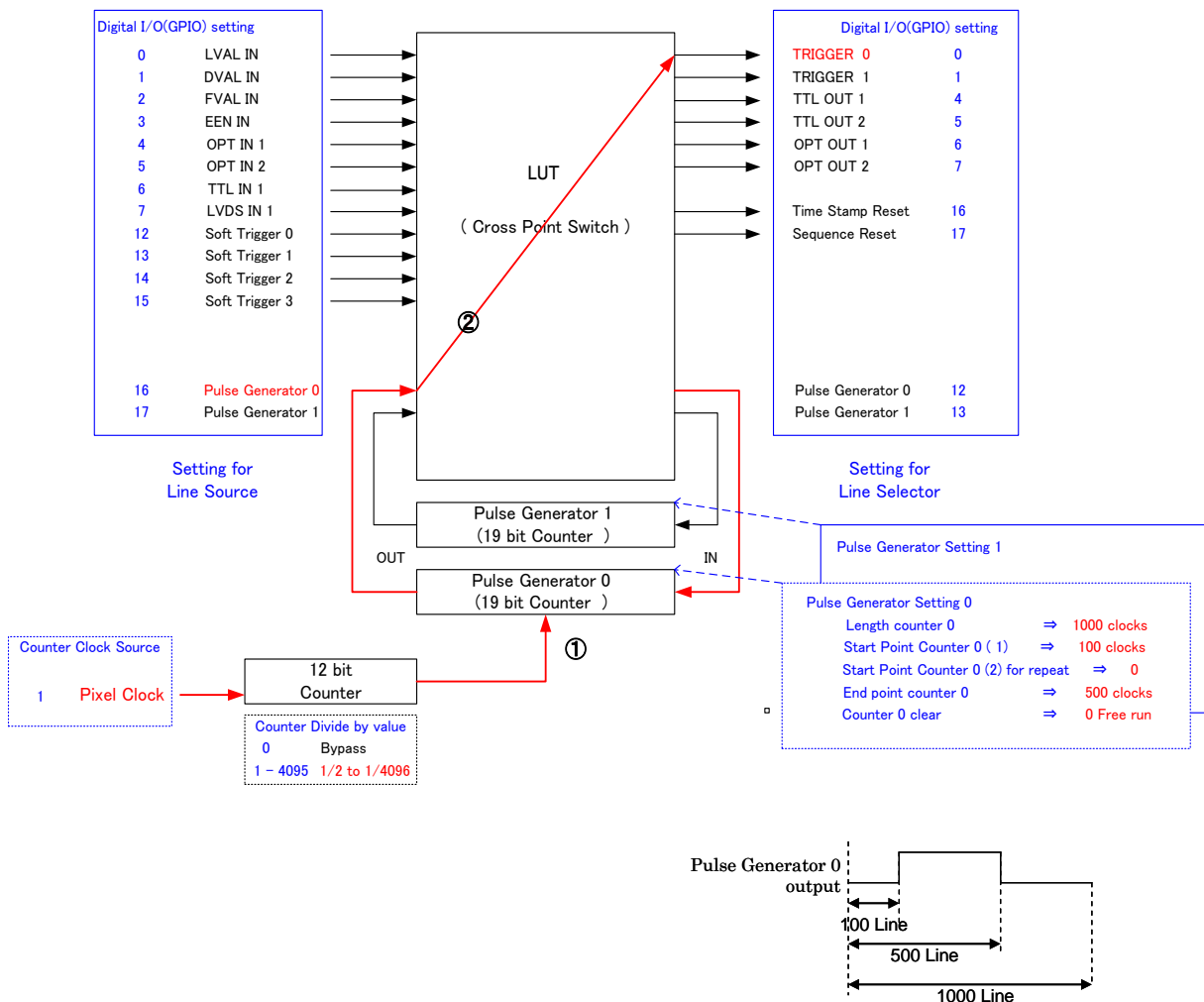

Fig.14 Pulse Generator 0 timing Example 2

7. Image output

7.1. CCD Sensor Layout

The CCD sensor layout with respect to pixels and lines used in the timing and video full frame read out is shown below.

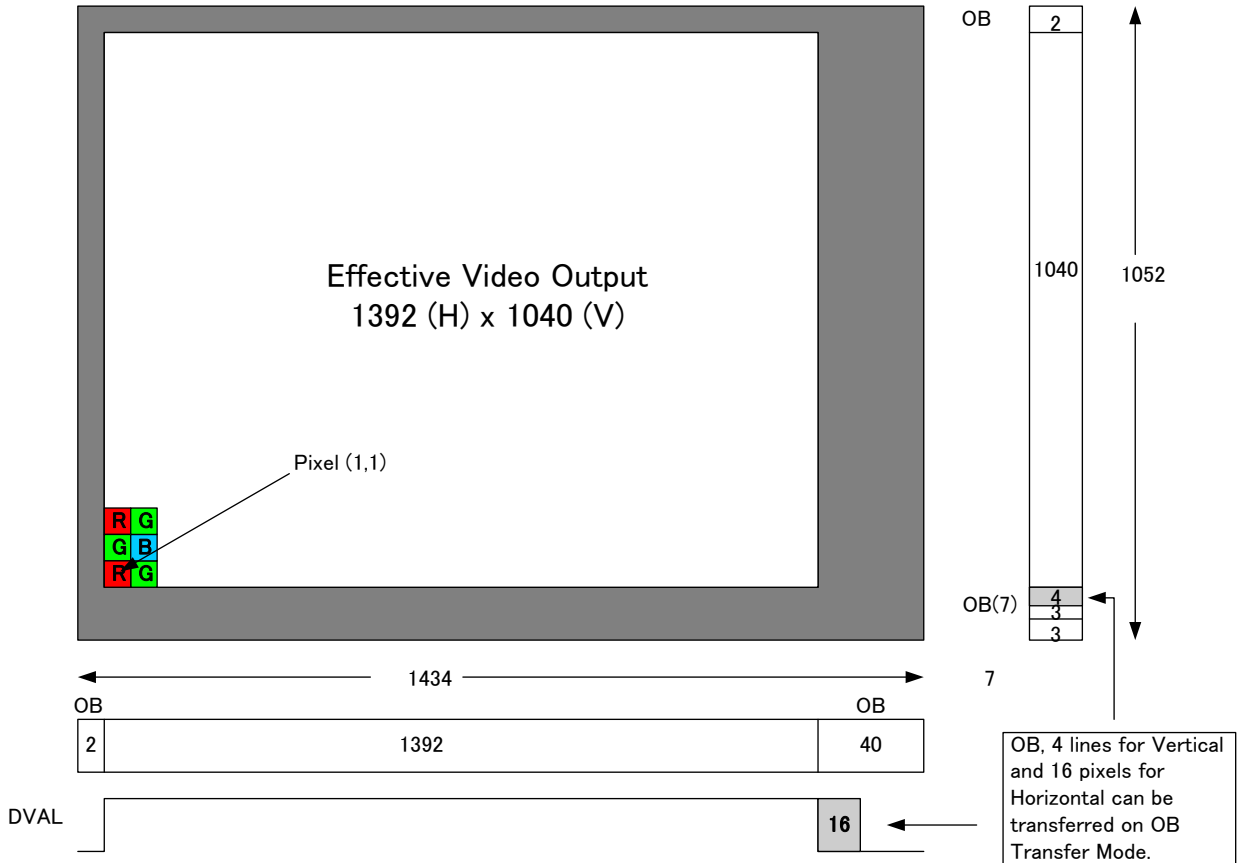

Fig.15 CCD sensor layout

Important Note: By using Optical Black (OB) transfer mode, the user can select whether to include optical black pixels in the image stream. This is for Horizontal only.

7.2. Vertical Binning (BM-141GE only)

The binning functions can be used to achieve higher frame rate or higher sensitivity. The drawback is lower resolution.

Vertical binning is done by adding the charge from pixels in adjacent lines in the horizontal CCD register. Fig.12 shows the vertical binning principle.

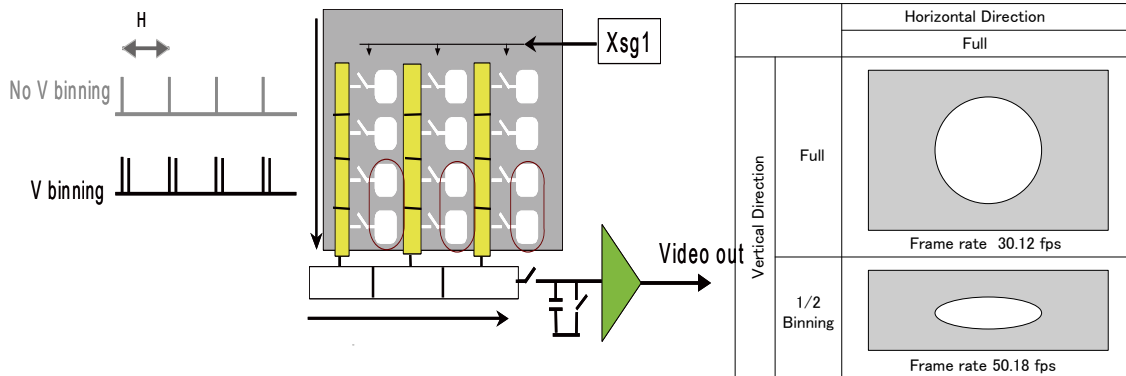

Fig.16. BM-141GE Vertical binning.

The BM-141GE has ON or OFF function for Vertical Binning:

Setting	Value for Register address 0xA084	Resolution	Frame rate
Off (no binning)	0x01	1392(h) x 1040(v) pixels	30.12 frames/sec.
2:1 binning	0x02	1392(h) x 520(v) pixels	50.18 frames /sec.

7.3. Partial Scanning (Fixed rate and variable)

The partial scanning function uses the middle of the image vertically to achieve faster frame rate. This is very useful when capturing and inspecting the image which does not require the height. BM-141GE/BB-141GE has 4 types of partial scan modes such as 2/3, 1/2, 1/4 and 1/8.

Mode	Start line	End line	Frame Rate
2/3	173	866	41.05 fps
1/2	261	780	50.06 fps
1/4	391	650	74.57 fps
1/8	455	584	98.73 fps

In addition to the mentioned fixed rate partial scan modes, BM/BB-141GE has variable partial scan mode. The start line can be set from 1st line to 1025 line and the scanned lines can be set from 8 lines to 1032 lines. Please note that if the odd line is selected as the start line, the Bayer color sequence is RGR and if the even line is selected, it is GBG.

BM-141GE / BB-141GE

◆ How to calculate total line number and frame rate on variable partial scan mode

Variable partial scan The start line setting 1st line to 1025th line
 Read out height 8 lines to 1032 lines

Total lines = OB period in the upper part of the frame (L) + Fast Dump period in the upper part of the frame (L) + Effective image period (L) + Fast dump period in the lower part of frame(L)

Where, OB period in the upper part of the frame 3L

Fast dump period for the upper part $Roundup\frac{StartlineNo.+7}{5}+2$

Fast dump period for the lower part $Roundup\frac{1039-EndLineNo.}{5}+2$

Frame rate (fps) = $1000000 / (\text{Horizontal pixel No} \times \text{Pixel clock} \times \text{Total lines})$

Horizontal Pixel number 1830
 Pixel clock 17.24138 ns

Calculation example

Read out: 1/2 partial at the center (520L), Stat line (261), End line (780)

OB period in the upper part of the frame 3L

Fast dump period for the upper part = $(261+7) \div 5 + 2 = 55.6 \rightarrow 56$

Fast dump period for the lower part = $(1039-780) \div 5 + 2 = 53.8 \rightarrow 54$

Total lines = $3+56+520+54=633$

Frame rate = $1000000 \div (1830 \times 17.24138 \times 633) = 50.06 \text{ fps}$

7.4. Digital video output

7.4.1 Digital Video Output (Bit Allocation)

Although the BM-141GE and BB-141GE are digital cameras, the image is generated by an analog component, the CCD sensor.

The table and diagram below show the relationship between the analog CCD output level and the digital output.

CCD out	Analog Signal *	Digital Out		
		8 bit	10 bit	12 bit
Black	Setup 3.6%, 25mV	8 LSB	32 LSB	128 LSB
200mV	700mV	222 LSB	890 LSB	3560 LSB
230mV	800mV	255 LSB	1023 LSB	4095 LSB

The standard setting for 10-bit video level is 890 LSB. 200 mV CCD output level equals 100% video output.

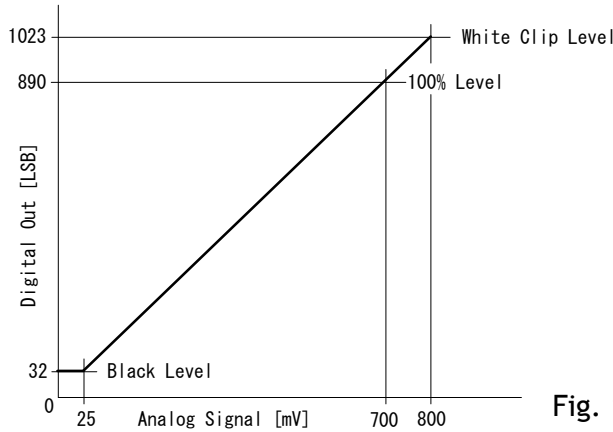

Important Note:

When Gain is set at -4.5db to -6dB, the linearity of the video output may be deteriorated around 100% video output level. Please confirm the output level characteristics when -4.5dB to -6dB gain is set.

Fig. 17. Digital Output (10 bit output)

7.4.2 Bit Allocation (Pixel Format / Pixel Type) - BM-141GE (monochrome)

In the GigE Vision Interface, GVSP (GigE Vision Streaming Protocol) is used for an application layer protocol relying on the UDP transport layer protocol. It allows an application to receive image data, image information and other information from a device.

In BM-141GE, the following pixel types supported by GVSP are available.

With regard to the details of GVSP, please refer to GigE Vision Specification available from AIA (www.machinevisiononline.org).

7.4.2.1 GVSP_PIX_MONO8 (8bit)

1 Byte								2 Byte								3 Byte							
Y0								Y1								Y2							
0	1	2	3	4	5	6	7	0	1	2	3	4	5	6	7	0	1	2	3	4	5	6	7

7.4.2.2 GVSP_PIX_MONO10 (10bit)

1 Byte								2 Byte								3 Byte								4 Byte								
Y0								Y0								Y1								Y1								
0	1	2	3	4	5	6	7	8	9	X	X	X	X	X	X	X	0	1	2	3	4	5	6	7	8	9	X	X	X	X	X	X

7.4.2.3 GVSP_PIX_MONO10_PACKED (10 bit)

1 Byte								2 Byte								3 Byte								4 Byte																							
Y0								Y1								Y2								Y3																							
2	3	4	5	6	7	8	9	0	1	X	X	0	1	X	X	2	3	4	5	6	7	8	9	2	3	4	5	6	7	8	9	0	1	X	X	0	1	X	X	2	3	4	5	6	7	8	9

7.4.2.4 GVSP_PIX_MONO12 (12 bit)

1 Byte								2 Byte								3 Byte								4 Byte							
Y0								Y0								Y1								Y1							
0	1	2	3	4	5	6	7	8	9	10	11	X	X	X	X	0	1	2	3	4	5	6	7	8	9	10	11	X	X	X	X

7.4.2.5 GVSP_PIX_MONO12_PACKED (12 bit)

1 Byte								2 Byte								3 Byte								4 Byte																							
Y0								Y1								Y2								Y3																							
4	5	6	7	8	9	10	11	0	1	2	3	0	1	2	3	4	5	6	7	8	9	10	11	4	5	6	7	8	9	10	11	0	1	2	3	0	1	2	3	4	5	6	7	8	9	10	11

BM-141GE / BB-141GE

Address	Internal Name	Access	Size	Value
0xA410	Pixel Format type	R/W	4	0x01080001:Mono8 0x01100003:Mono10 0x010C0004:Mono10 Packed 0x01100005:Mono12 0x010C0006:Mono12 Packed

7.4.3 Bit Allocation (Pixel Format / Pixel Type) - BB-141GE (Bayer mosaic color)

In the GigE Vision Interface, GVSP (GigE Vision Streaming Protocol) is used for an application layer protocol relying on the UDP transport layer protocol. It allows an application to receive image data, image information and other information from a device. In BB-141GE, the following pixel types supported by GVSP are available. With regard to the details of GVSP, please refer to GigE Vision Specification available from AIA.

7.4.3.1 GVSP_PIX_BAYRG8 “BayreRG8 “

Odd Line

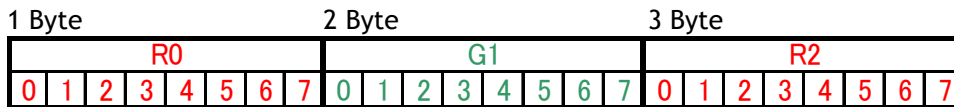

Even Line

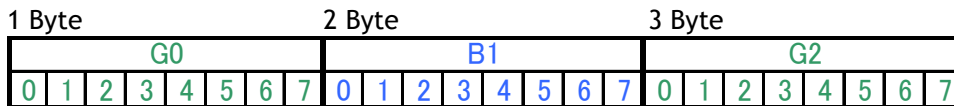

7.4.3.2 GVSP_PIX_BAYRG10 “Bayer RG10”

Odd Line

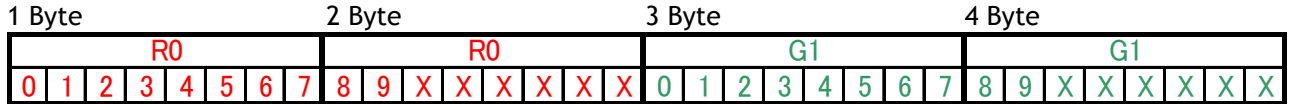

Even Line

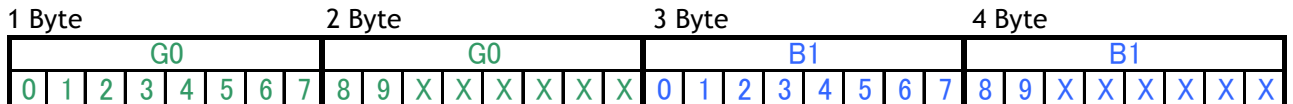

7.4.3.3 GVSP_PIX_BAYRG12 “ Bayer RG12”

Odd Line

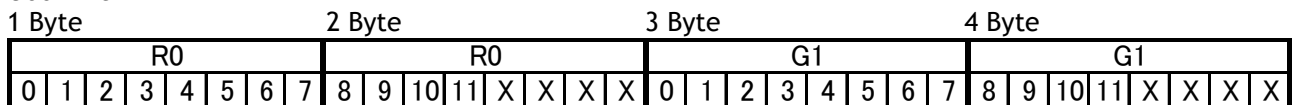

Even Line

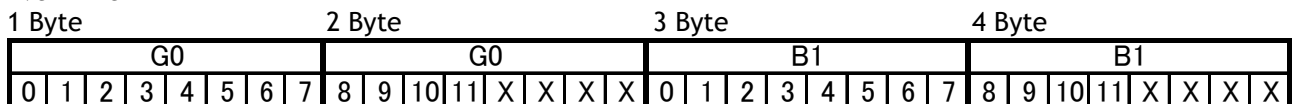

7.4.3.4 GVSP_PIX_BAYGB8 “Bayer GB8”

Odd Line

1 Byte								2 Byte								3 Byte							
G0								B1								G2							
0	1	2	3	4	5	6	7	0	1	2	3	4	5	6	7	0	1	2	3	4	5	6	7

Even Line

1 Byte								2 Byte								3 Byte							
R0								G1								R2							
0	1	2	3	4	5	6	7	0	1	2	3	4	5	6	7	0	1	2	3	4	5	6	7

7.4.3.5 GVSP_PIX_BAYGB10 “ Bayer GB10”

Odd Line

1 Byte								2 Byte								3 Byte								4 Byte							
G0								G0								B1								B1							
0	1	2	3	4	5	6	7	8	9	X	X	X	X	X	X	0	1	2	3	4	5	6	7	8	9	X	X	X	X	X	X

Even Line

1 Byte								2 Byte								3 Byte								4 Byte							
R0								R0								G1								G1							
0	1	2	3	4	5	6	7	8	9	X	X	X	X	X	X	0	1	2	3	4	5	6	7	8	9	X	X	X	X	X	X

7.4.3.6 GVSP_PIX_BAYGB12 “ Bayer GB12”

Odd Line

1 Byte								2 Byte								3 Byte								4 Byte							
G0								G0								B1								B1							
0	1	2	3	4	5	6	7	8	9	10	11	X	X	X	X	0	1	2	3	4	5	6	7	8	9	10	11	X	X	X	X

Even Line

1 Byte								2 Byte								3 Byte								4 Byte							
R0								R0								G1								G1							
0	1	2	3	4	5	6	7	8	9	10	11	X	X	X	X	0	1	2	3	4	5	6	7	8	9	10	11	X	X	X	X

Address	Internal Name	Access	Size	Value
0xA410	Pixel Format type	R/W	4	0x01080009: BAYRG8
				0x0108000A: BAYGB8
				0x0110000D: BAYRG10
				0x0110000E: BAYGB10
				0x01100011: BAYRG12
				0x01100012: BAYGB12

Note: BB-141GE has the same Bayer sequence for Full and any of partial scanning as RG. Therefore, comparing full scanning and partial scanning, the center might be shifted.

Note: As the Pixel Format type, BB-141GE supports BAYER GB 8, BAYER GB 10 and BAYER GB12. When this type is selected, the output starts from 2nd line for all scanning.

7.5. BB-141GE. Bayer mosaic filter

BB-141GE is a color camera based on a CCD sensor with a Bayer RGB color mosaic. The color image reconstruction is done in the host PC. The Color sequence in the video signal is the same for all scanning formats.

The line readout follows LVAL.
The first valid pixel is the same timing as DVAL.

The Bayer color sequence starts with:

- RGR for odd line numbers.
- GBG for even line numbers.

Figure 13 shows the timing sequence for the Bayer mosaic read-out for the available partial scan modes.

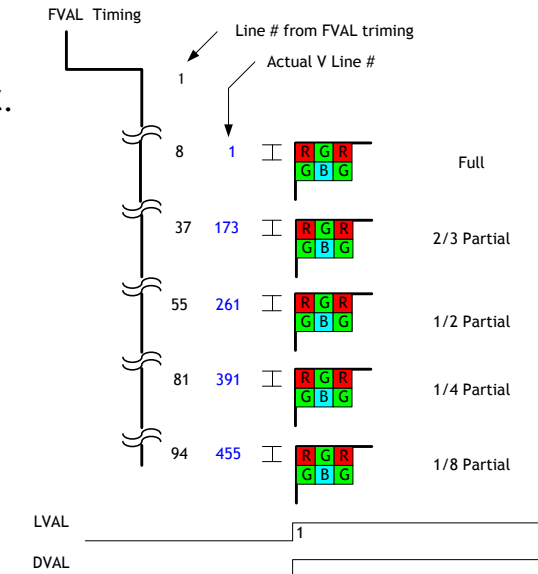

Fig.18. Bayer layout for each scanning

7.6. Image timing

7.6.1 Horizontal timing

The LVAL period is shown for normal continuous mode.

1 LVAL 1830 clk=31.551 us 1clk=17.241 ns

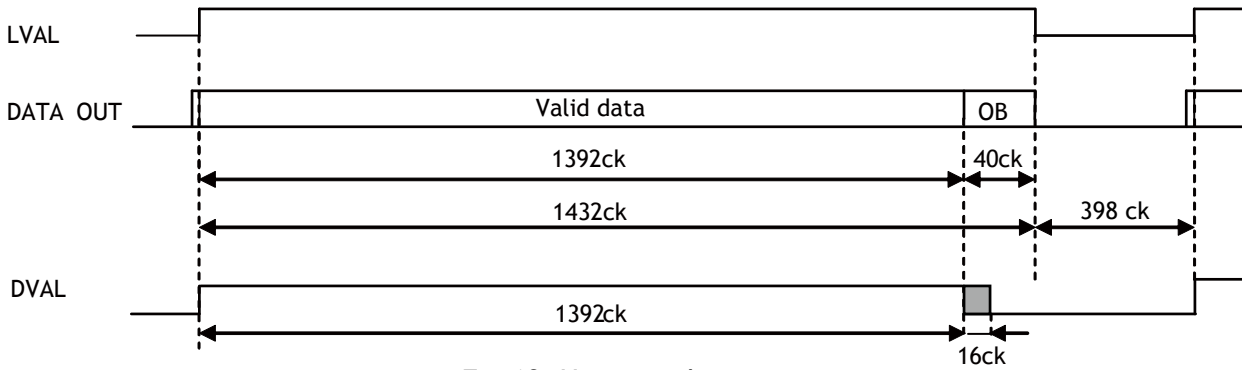

Fig.19 Horizontal timing

7.6.2 Vertical timing

The FVAL period for normal continuous mode full scan is shown.

FULL FRAME READ OUT FRAME RATE 1052L 30.12 fps

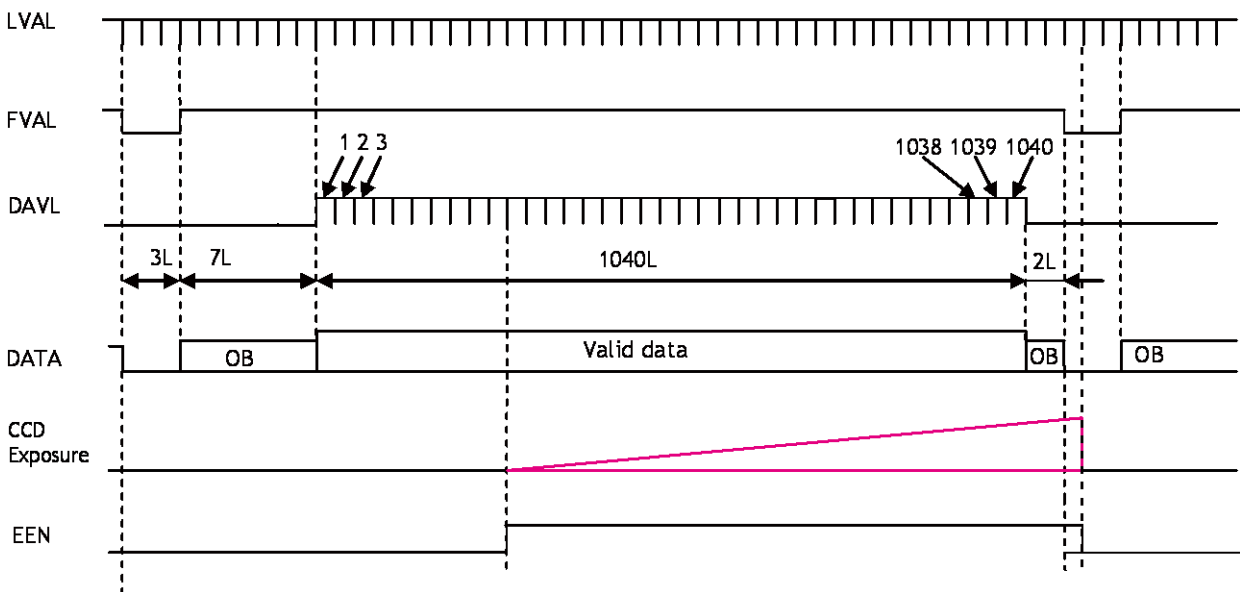

Fig.20 Vertical timing for full scan

7.6.3 Partial Scanning

The FVAL period is shown for 1/2 partial scan in normal continuous mode.

Vertical Timing

The diagram and table below provide vertical timing information for the fixed partial scan settings 1/2, 1/4, 1/3 and 2/3.

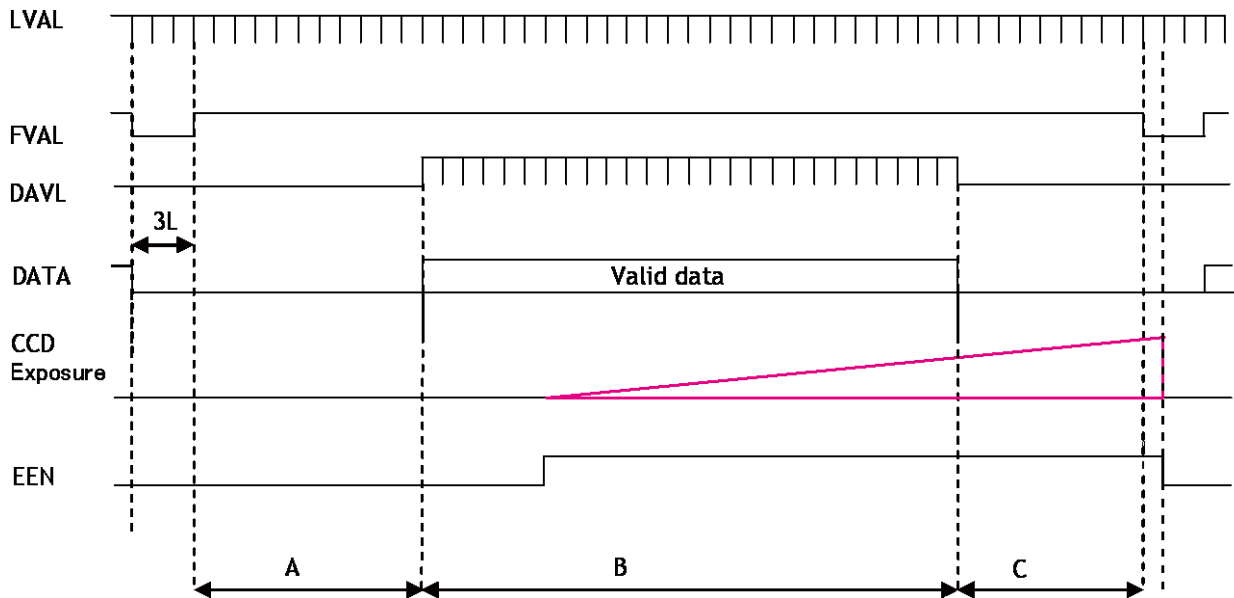

Values for vertical timing in partial scan continuous mode.

AREA	FVAL Low (L)	A (L)	B (L)		C (L)	Total line	frame rate
			Start line	End line			
2/3	3	38	694		37 L	772 L	41.05
			173	866			
1/2	3	56	520		54 L	633 L	50.06
			261	780			
1/4	3	82	260		80 L	425 L	74.57
			391	650			
1/8	3	95	130		93 L	321 L	98.73
			455	584			

Fig.21 Vertical timing for partial scanning

Horizontal Timing

The horizontal timing is the same as that of the full scanning.

1 LVAL 1830 clk=31.551 us 1clk=17.241 ns

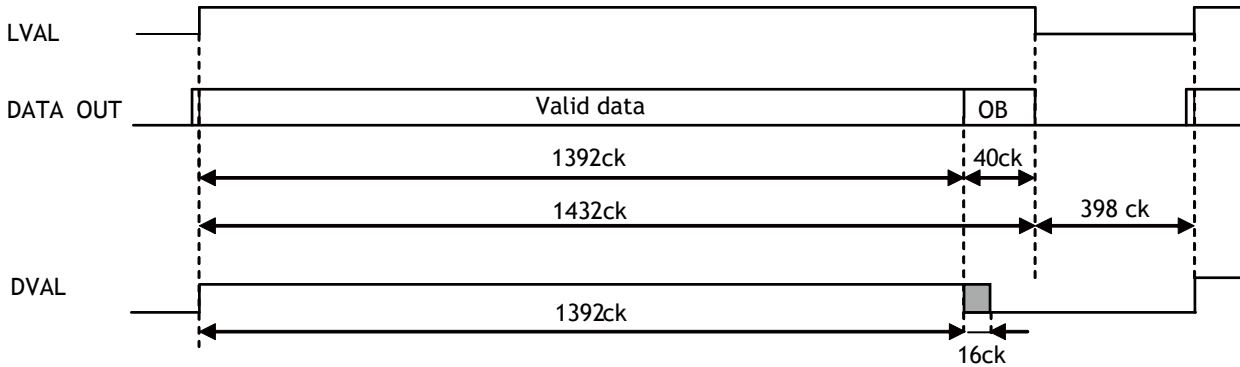

Fig.22 Horizontal Timing for Partial Scanning

7.6.4 Vertical binning

Vertical binning combines charge from two adjacent lines, reducing the vertical resolution to half and at the same time increasing frame rate and sensitivity. By activating this function, the frame rate is increased to 50.18 fps. This function is available only for BM-141GE.

Important Note

Vertical Binning cannot be used together with the Partial Scanning.

Horizontal Timing

Vertical Binning

1LVAL 2193 ck=37.810 us

1ck=17.241 us

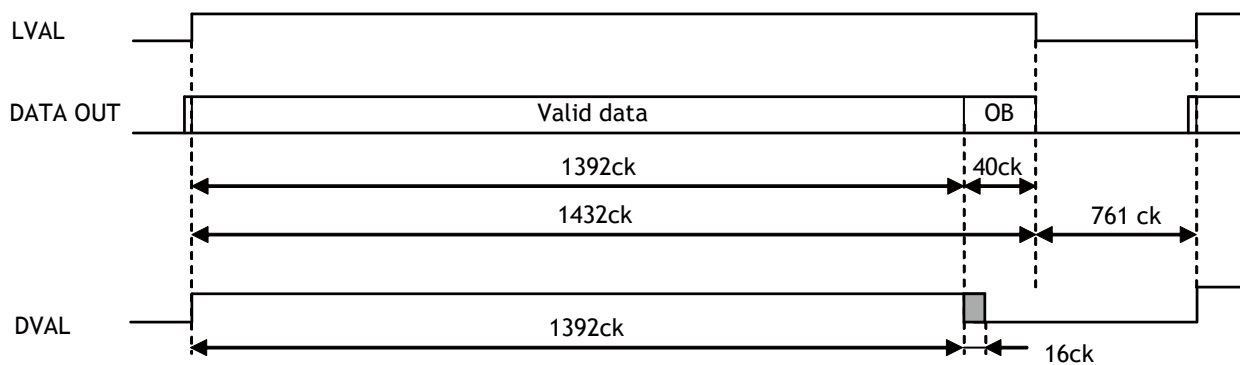

Fig.23 Horizontal Timing for Vertical Binning

Vertical timing

Vertical Binning FRAME RATE 527L 50.18 fps

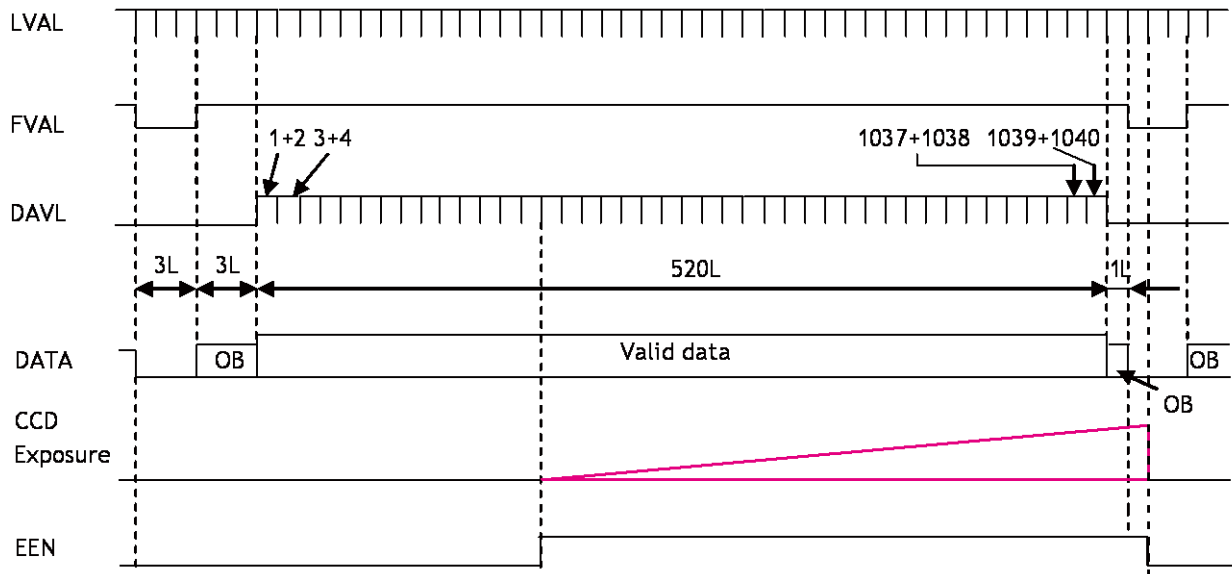

Fig.24 Vertical Timing for Vertical Binning

7.7. Auto-Iris Lens video output (12-pin Hirose connector)

This analogue signal is not routed through the GPIO. This signal is available at pin 4 of 12-pin Hirose connector. It can be used for lens iris control in Continuous mode only. The signal is taken after the CCD sensor output passes through the gain circuit. The video output is without sync. The signal is 0.7 Vp-p. To get this signal, the internal DIP switch (SW 601) must be set. Refer to chapter 5.4.

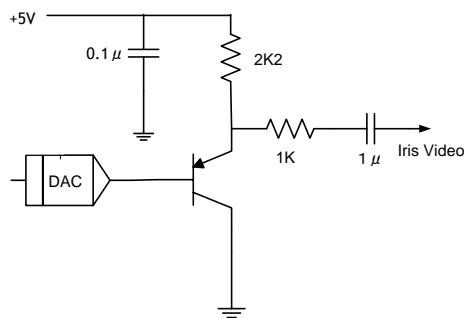

Fig. 25. Video output circuit.

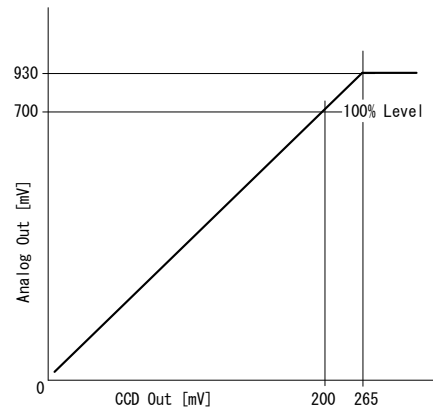

Fig. 26. Iris Video

8. Network configuration

- For details of the network settings, please refer to the “Getting Started Guide” supplied with the JAI SDK.

8.1. GigE Vision Standard Interface

The BM-141GE and BB-141GE are designed in accordance with the GigE Vision standard. It transmits digital images over Cat5e or Cat6 Ethernet cables. All camera functions are also controlled via the GigE Vision interface.

The camera can operate in continuous mode, providing an endless stream of images. For capturing individual images, related to a specific event, the camera can also be triggered. For precise triggering, it is recommended to use a hardware trigger applied to the Hirose 12-pin connector. It is also possible to initiate a software trigger through the GigE Vision interface. However, when using software trigger, certain latency inherent to the GigE interface must be anticipated. This latency, that manifests itself as jitter, greatly depends on the general conditions and traffic on the GigE connection. The frame rate described in this manual is for the ideal case and may deteriorate depending on conditions.

When using multiple cameras (going through a switch and/or a single path) or when operating in a system with limited transmission bandwidth the Delayed Readout Mode and Inter-Packet Delay functions can be useful.

8.2. Equipment to configure the network system

8.2.1 PC

The PC used should have the following performance or better

- 1) Recommended CPU : Core2 Duo 2.4GHz or better,
Better than Core2 Extreme
- 2) Recommended memory : 2Gbyte or more
- 3) Video card : Better than PCI Express Bus Ver.1.0 x16
VRAM should be better than 256MByte, DDR2
- 4) Other : The resident software should not be used

8.2.2 Cables

GigEVision configures the system by using 1000BASE-T. (100BASE-T can be used with some restriction. Refer to chapter 8.3.6). In the market, CAT5e (125MHz), CAT6 (250MHz) and CAT7 (600MHz) cables are available for 1000BASE-T. There are crossover cables and straight through cables available. Currently, as most equipment complies with Auto MDI/MDI-X, please use straight through cables. (Among crossover cables, a half crossover type exists, which the Ethernet will recognize as 100BASE-T).

8.2.3 Network card (NIC)

The network card should comply with 1000BASE-T and also have the capability of JUMBO FRAMES. When the jumbo frame size is set at a larger number, the load on the CPU will be decreased. Additionally, as the overhead of the packet is decreased, the transmission will have more redundancy.

BM-141GE / BB-141GE

JAI confirms the following network cards.

NIC Manufacture	Type	PCI-X Bus	PCI-Express Bus	
Intel	PRO/1000MT Server Adapter	√	—	32bit or 64bit 33/66/100/133 MHz
Intel	PRO/1000MT Dual Port Server Adapter	√	—	32bit or 64bit 33/66/100/133 MHz
Intel	PRO/1000GT Quad Port Server Adapter	√	—	32bit or 64bit 66/100/133 MHz
Intel	PRO/1000PT Server Adapter	—	√ (x1)	2.5Gbps uni-directional 5Gbps bi-directional
Intel	Pro/1000 CT Desktop adaptor	—	√ (x1)	2.5Gbps uni-directional 5Gbps bi-directional
Intel	Gigabit ET2 Quad port Server Adapter	—	√ (x4)	10Gbps uni-directional 20Gbps bi-directional
Intel	Gigabit ET Dual port Server Adapter	—	√ (x4)	10Gbps uni-directional 20Gbps bi-directional
Intel	Gigabit EF Dual port Server Adapter	—	√ (x4)	10Gbps uni-directional 20Gbps bi-directional

8.2.4 Hub

It is recommended to use the metal chassis type due to the shielding performance. As the hub has a delay in transmission, please note the latency of the unit.

8.3. Recommended Network Configurations

Although the BM-141GE and BB-141GE series conform to Gigabit Ethernet (IEEE 802.3) not all combinations of network interface cards (NICs) and switches/routers are suitable for use with the GigE Vision compliant camera.

JAI will endeavor to continuously verify these combinations, in order to give users the widest choice of GigE components for their system design.

➡ For details of the network settings, please refer to the “Getting Started Guide” supplied with the JAI SDK.

8.3.1 Guideline for network settings

To ensure the integrity of packets transmitted from the camera, it is recommended to follow these simple guidelines:

1. Whenever possible use a peer-to-peer network.
2. When connecting several cameras going through a network switch, make sure it is capable of handling jumbo packets and that it has sufficient memory capacity.
3. Configure inter-packet delay to avoid congestion in network switches.
4. Disable screen saver and power save functions on computers.
5. Use high performance computers with multi-CPU, hyper-thread and 64-bit CPU, etc.
6. Only use Gigabit Ethernet equipment and components together with the camera.
7. Use at least Cat5e and preferably Cat6 Ethernet cables.
8. Whenever possible, limit the camera output to 8-bit.

8.2.2 Video data rate (network bandwidth)

The video bit rate for BM-141GE and BB-141GE at the continuous mode is:

Model	Pixel Type	Packet data volume (In case the Packet size is 1428)
BM-141GE	MONO8	362 Mbit/s
	MONO10_PACKED MONO12_PACKED	544 Mbit/s
	MONO10/MONO12	725 Mbit/s
BB-141GE	BAYRG8,BAYGB8	362 Mbit/s
	BAYRG10,BAYBG10 BAYRG12,BAYGB12	725 Mbit/s

- ◆ In the case of using Jumbo Frames, the packet data will be improved by 2 %.
- ◆ For BM-141GE and BB-141GE, the jumbo frame size can be a maximum 16384 Bytes (factory setting is 1428 Bytes). The NIC must also be set to support Jumbo Frames(see chapter 8.2.4).
- ◆ Based on the Pixel Type, the packet size may be automatically adjusted inside the camera to its most suitable value .

8.3.3 Note for setting packet size

The packet size is set to 1428 as the factory default. Users may enter any value for the packet size and the value will be internally adjusted to an appropriate, legal value that complies with the GenICam standard. The packet size can be modified in the GigE Vision Transport Layer Control section of the camera control tool.

Regarding data transfer rate, a larger packet size produces a slightly lower data transfer rate. The BM-500GE and BB-500GE series can support a maximum of 4040 byte packets provided the NIC being used has a Jumbo Frames function with a setting of a 4040 bytes or larger.

Caution: Do not set the packet size larger than the maximum setting available in the NIC or switch to which the camera is connected . Doing so will cause output to be blocked.

8.3.4 Calculation of Data Transfer Rate

Setting parameter

Item	Unit	Symbol
Image Width	[pixels]	A
Image Height	[pixels]	B
Bits per Pixel	[bits]	C
Frame Rate	[fps]	D
Packet Size	[Bytes]	E
Number of Packets (including Data Leader & Trailer Packet)	[packets]	G
DataTransfer Rate	[Mbit/s]	J

Fixed value

Item	Unit	value
Data Leader Packet Size	[Bytes]	90
Data Trailer Packet Size	[Bytes]	62

BM-141GE / BB-141GE

Formula to calculate Data Transfer Rate

$$J = \frac{\{90 + 62 + (E + 18) * (G - 2)\} * 8 * D}{1000000}$$

Where,

$$G = \text{ROUNDUP}\left\{\frac{A * B * C}{8 / (E - 36)}\right\} + 2$$

The following table shows Bits per Pixel (C) which depends on the pixel format.

Pixel format	Bit
MONO8	8
MONO10	16
MONO10Packed	12
MONO12	16
MONO12Packed	12
BAYRG8	8
BAYGB8	8
BAYRG10	16
BAYGB10	16
BAYRG12	16
BAYGB12	16

Calculation example: BM-141GE Pixel type Mono8

Item	Unit	Symbol	Setting
Image Width	[pixels]	A	1392
Image Height	[pixels]	B	1040
Bits per Pixel	[bits]	C	8
Frame Rate	[fps]	D	30.12
Packet Size	[Bytes]	E	1428
Number of Packets (including Data Leader & Trailer Packet)	[packets]	G	
Transfer Data Rate	[Mbit/s]	J	

$$G = \text{ROUNDUP}\left\{\frac{(1392 \times 1040 \times 8 / 8 / (1428 - 36))}{1}\right\} + 2 = 1040 + 2 = 1042$$

$$J = \frac{\{90 + 62 + (1428 + 18) \times (1042 - 2)\} \times 8 \times 30.12}{1000000} = 362 \text{ Mbit/s}$$

8.3.5 Simplified calculation (Approximate value)

A simple way to calculate the approximate data transfer rate is the following.
 Transfer data = Image width (pixel) x Image Height (pixel) x depth per pixel (depending on the pixel format) x frame rate / 1,000,000 (convert to mega bit)

In the case of the BM-141GE with the full image and MONO8 pixel format;
 The data transfer rate = $1392 \times 1040 \times 8 \times 30.12 / 1000000 = 349 \text{ Mbit/s}$

8.3.6 Note for 100BASE-TX connection

- ◆ In order to use 100Mbps network, 100BASE-TX and Full Duplex are available. Half Duplex cannot be used.
- ◆ In the case of connecting on 100BASE-TX, the maximum packet size should be 1500 byte.
- ◆ In the case the of connecting on 100BASE-TX, the specifications such as frame rate, trigger interval and so on described in this manual cannot be satisfied.

Pixel Type	Frame rate at Full Frame scan[fps]
MONO8, BAYRG8, BAYGB8	8.0 ~ 8.2
MONO10_PACKED, MONO12_PACKED	5.4 ~ 5.6
MONO10, MONO12, BAYRG10, BAYGB10, BAYRG12, BAYGB12	4.0 ~ 4.2

8.4. GigE camera connecting examples

8.4.1 Using a switching hub for 1 port

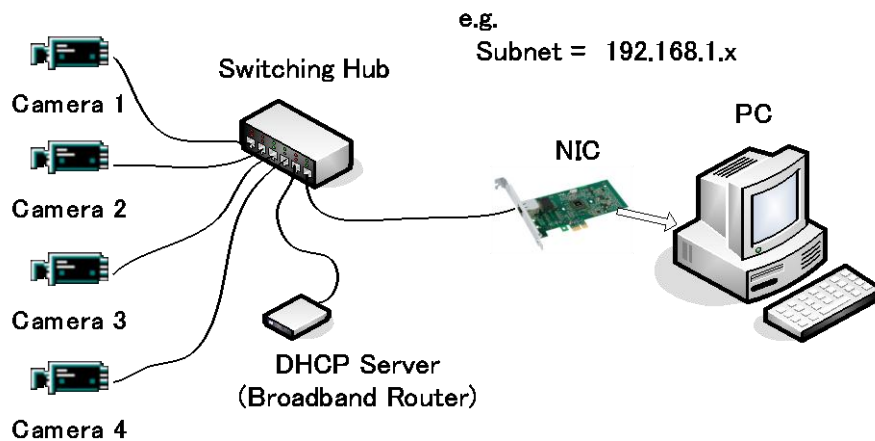

- ◆ All cameras and NIC belong to the same subnet
- ◆ The accumulated transfer rate for all cameras should be within 800Mbps
- ◆ The packet size and the packet delay should be set appropriately in order for the data not to overflow in the switching hub.

8.4.2 Connecting a camera to each port of a multi-port NIC

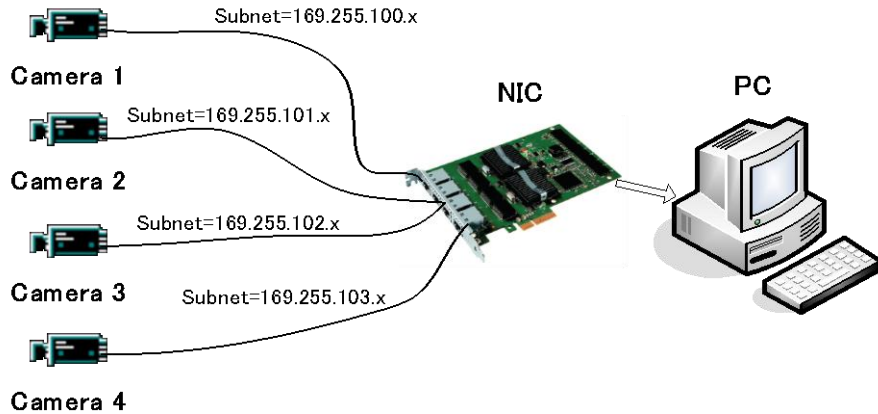

- ◆ This is the example for using a 4-port NIC
- ◆ The pair of the connecting camera and the NIC constructs one subnet. As for the IP configuration, it is appropriate to use the persistent IP.
- ◆ In this case, each camera can use the maximum 800Mbps bandwidth. However, the load for the internal bus, CPU and the application software will be heavy, so a powerful PC will most likely be required.

8.4.3 The data transfer for multiple cameras

8.4.3.1 If delayed readout is not used in continuous mode

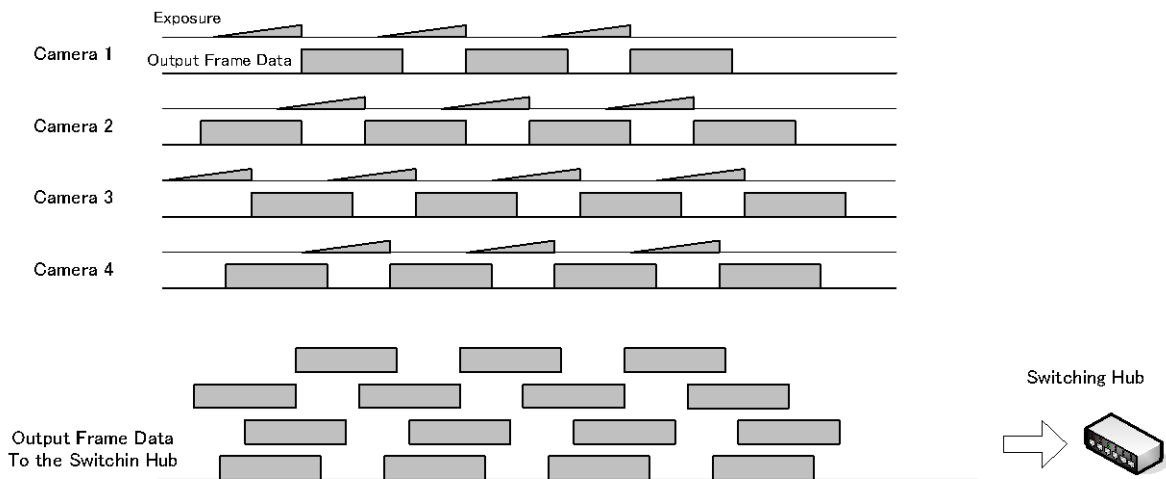

- ◆ The packet delay should be set larger. The data traffic is controlled by the buffer of the hub. It is necessary to check the buffer value of the unit.

8.4.3.2 If delayed readout is not used in trigger mode

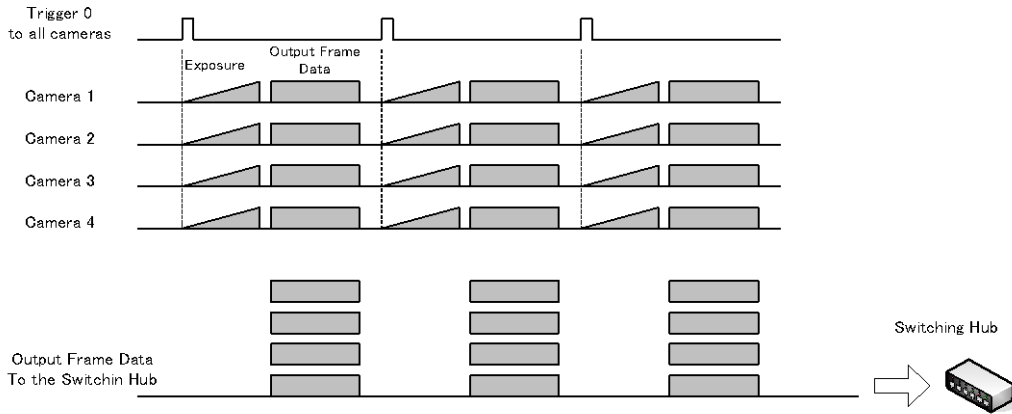

- ◆ The packet delay should be set larger. The data traffic is controlled by the buffer of the hub. It is necessary to check the buffer value of the unit.

8.4.3.3 If delayed readout is used

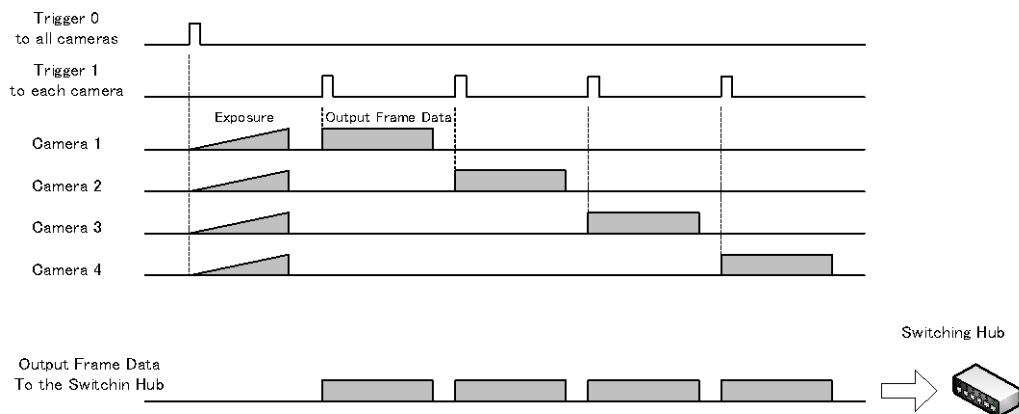

- ◆ The packet delay should be set smaller, and the packet delay trigger controls the data traffic. If the camera has a pulse generator, it can control the data traffic.

9. Basic functions

The BM-141GE and BB-141GE cameras are progressive scan cameras with 12, 10 or 8-bit video output in Gigabit Ethernet. The camera has 1/2, 1/4 or 1/8 partial scanning for faster frame rates. Vertical binning and Draft mode are also available.

The camera can operate in continuous mode as well as in 6 triggered modes:

- Edge Pre-select Trigger (EPS)
- Pulse Width Control Trigger (PWC)
- Reset Continuous Trigger (RCT)
- Sequential EPS Trigger (EPS)
- Delayed readout EPS Trigger (EPS)
- Delayed readout PWC Trigger (PWC)

Depending on the timing of the trigger input in relationship to FVAL (camera internal Frame valid clock), the start of exposure can be immediate (no-delay, LVAL asynchronous) or delayed until next LVAL (LVAL synchronous).

In the following section the functions are described in detail.

9.1. Electronic Shutter

BM-141GE / BB-141GE have conventional shutter functions as well as the GenICam standard “Exposure Time Abs” function.

Preset Shutter

9 steps preset shutter are available: OFF (1/30); 1/60, 1/100, 1/250, 1/500, 1/1,000, 1/2,000, 1/4,000, 1/8,000, 1/10,000 sec. (See the register map included in the SDK documentation for details how to configure this register - 0xA004)

Programmable Shutter

It is possible to set the shutter speed in the range of 2L to 1052L by 1L unit, in case of Full Frame operation. When 1052L is set, it is the equivalent of “OFF (1/30)” or 33.19ms. (See the register map included in the SDK documentation for details how to configure this register - 0xA008)

	Minimum Shutter Time 2L	Maximum Shutter Time
Normal	$31.551 \mu\text{s}(1\text{L}) * 2\text{L} = 63.102 \mu\text{s}$	$31.551 \mu\text{s} * 1052 \text{L} \approx 33.192 \text{ms}$
V Binning	$37.810 \mu\text{s} * 2\text{L} = 75.62 \mu\text{s}$	$37.810 \mu\text{s} * 527 \text{L} \approx 19.926 \text{ms}$
Draft	$36.879 \mu\text{s} * 2\text{L} = 73.759 \mu\text{s}$	$36.879 \mu\text{s} * 268 \text{L} \approx 9.883 \text{ms}$

Pulse Width Control

When this mode is selected, the exposure time is controlled by the width of the trigger pulse. The minimum trigger pulse width is equal to 2L (63µs) and the maximum is 2 seconds.

Exposure Auto Continuous (Auto Shutter)

In this mode, the shutter continuously functions in the range of OFF to 1/500 s.

Exposure Time Abs (GenICam Standard)

This is a function specified in the GenICam standard.

The shutter speed can be entered as an absolute exposure time in microseconds (µs) in register address 0xA018. The entered absolute time (Time Abs) is then converted to programmable exposure (PE) value inside the camera.

The below calculating formula shows the relationship between the PE value used by the camera for the different readout modes and the value entered in register 0xA018. Due to round down figure, some errors may occur.

The relation between PE value and Time Abs

Normal readout PE= 2 + INT (Exposure time -63) μ s / (1830/58000000)

V Binning readout PE= 2 + INT (Exposure time -75) μ s / (2193/58000000)

INT means round down.

The following table shows minimum value and maximum value for each readout mode.

	Minimum value	Maximum Value
Normal Scan	63 .103 μ s	33192 μ s
2/3 Partial Scan	63 .103 μ s	24358 μ s
1/2 Partial Scan	63 .103 μ s	19973 μ s
1/4 Partial Scan	63 .103 μ s	13410 μ s
1/8 Partial Scan	63 .103 μ s	10128 μ s
V-Binning Scan	75.62 μ s	19926 μ s

GPIO in combination with Pulse Width trigger

More precise exposure time can be obtained by using GPIO in combination with Pulse Width mode. The clock generator and counter can be programmed in very fine increments. As for the setting example, refer to chapter 6.5.1.

9.2. Full Auto Exposure function

The Full Auto Exposure function combines three automatic functions; Lens Auto Iris, Auto Gain Control(AGC) and Auto Shutter. When dealing with widely varying lighting conditions, these automatic functions can be made to work in a coordinated fashion to control exposure for a constant video level output. This function makes the BM-141GE and BB-141GE well-suited for Intelligent Traffic Systems (ITS) and high-end security or surveillance applications. Full Auto Exposure requires the use of a video controlled auto-iris lens system. The lens should be connected while the power to the camera is OFF.

This Full Auto Exposure function operates as described below.

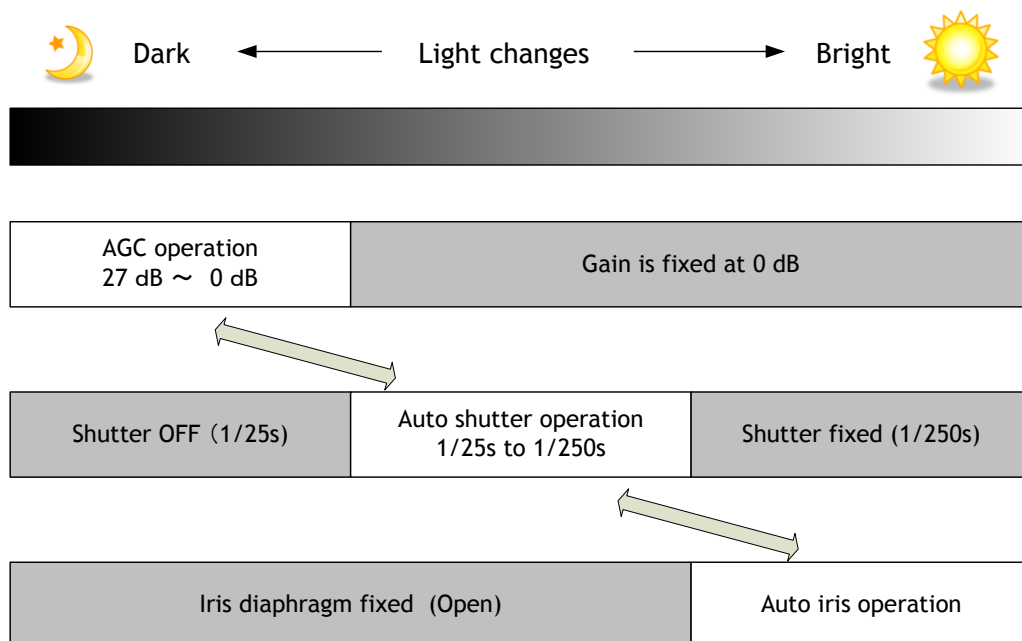

BM-141GE / BB-141GE

Related registers and settings for Full Auto Exposure are shown the following table.

Register	Display in SDK	Value	Setting for Full Auto Exposure
0xA034	Auto iris Lens Control Signal output	0=OFF 1=ON	1=ON(Default)
0xA000	Shutter mode	0= Preset shutter 1=Programmable exposure 2=Exposure TimeAbs 3=CCD iris	3=CCD iris
0xA0B0	AGC select	0=OFF, 1=ON	1=ON

The automatic functions used for Full Auto Exposure can be configured in various ways to support different application requirements. The table below shows combinations and functions.

Auto Iris Lens Control Signal output = ON (Default)			
		AGC	
		ON	OFF
Auto Shutter	ON	Full Auto Exposure operation	Auto Shutter + Lens Iris
	OFF	Lens iris + AGC	Only Lens Iris
Auto Iris Lens Control Signal Output = OFF			
		AGC	
		ON	OFF
Auto Shutter	ON	AGC + Auto Shutter	Only Auto Shutter
	OFF	Only AGC	No Auto functions available

9.3. Pre-process functions

BM-141GE/BB-141GE is provided with several pre-processing functions. The output from the camera is selectable to 8, 10 or 12-bit but video is digitized to 14 bits quantization. The pre-processing functions make use of the 14 bit video. Featured functions are: Bayer color white balance, R/L channel balance, blemish compensation, gain control and LUT (Look Up Table) for Gamma and Knee correction.

9.3.1 Bayer White Balance (BB-141GE only)

Normally, the raw Bayer color signals are sent to the host as they are. In the host, the signals are interpolated to generate an RGB image and perform white balance.

In order to offload the host, the BB-141GE can adjust Gr, R, Gb and B levels individually to get the white balance for the Bayer output signal. The gain is fixed to 1.0 for BM-141GE.

BB-141GE has Manual white balance, One-push Auto white balance, Continuous Auto white balance and Preset white balance of 3200K, 4600K and 5600K.

Note: Bayer white balance must be set at Normal mode.

9.3.2 Automatic Gain Control

This is the function to keep a constant output level in accordance with ambient brightness changes. The range of AGC as well as manual adjustment is -6dB to 24 dB.

This function set AGC ON or OFF.

Note: This is available only in Normal mode.

9.3.3 Programmable Look UP table (LUT)

BM-141GE/BB-141GE has a programmable look-up table (LUT) that can be used to adjust the transfer function of the video output. In other words, LUT can be used to create a user defined Knee of Gamma function. In order to get a desired set of characteristics, LUT Values should be set at each LUT Index (0 to 255). For instance, if the gamma is set to 0.45, LUT Value in the dark portion should be high and it should be smaller as the signal level becomes high. Please refer to the following drawing.

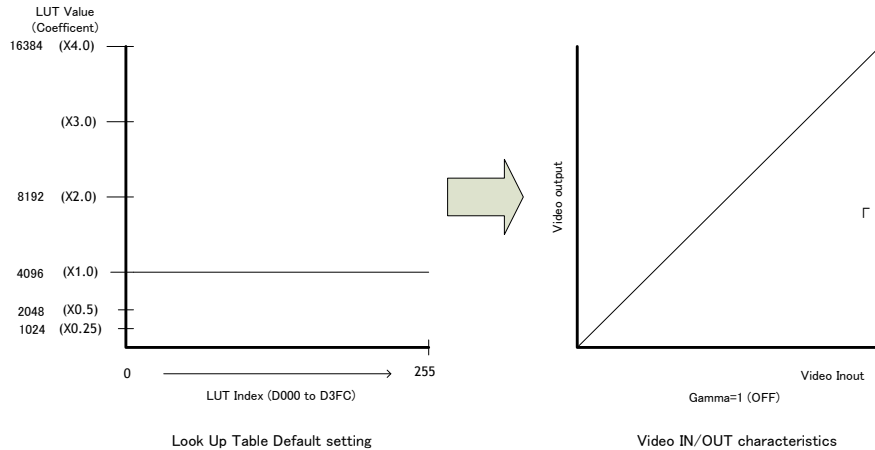

Fig. 27 LUT default setting (Coefficient: x1.0=4096)

The LUT consists of a data table of each gain which corresponds to all possible CCD outputs. In the Control Tool, each LUT Value is displayed as a coefficient (actual LUT value/4096). Signals multiplied by these LUT coefficients create the desired output signal characteristics. The look up table has 256 setting points of 14 bits covering the full range of input signals. On each point, the gain can be set to get desired output characteristics. Gr, R, Gb and B signals in BB-500GE have the same characteristics.

The Look Up Table is handled in a 14-bit Video Process circuit and a processed signal is output as a 8-,10- or 12-bit pixel format through GigE interface.

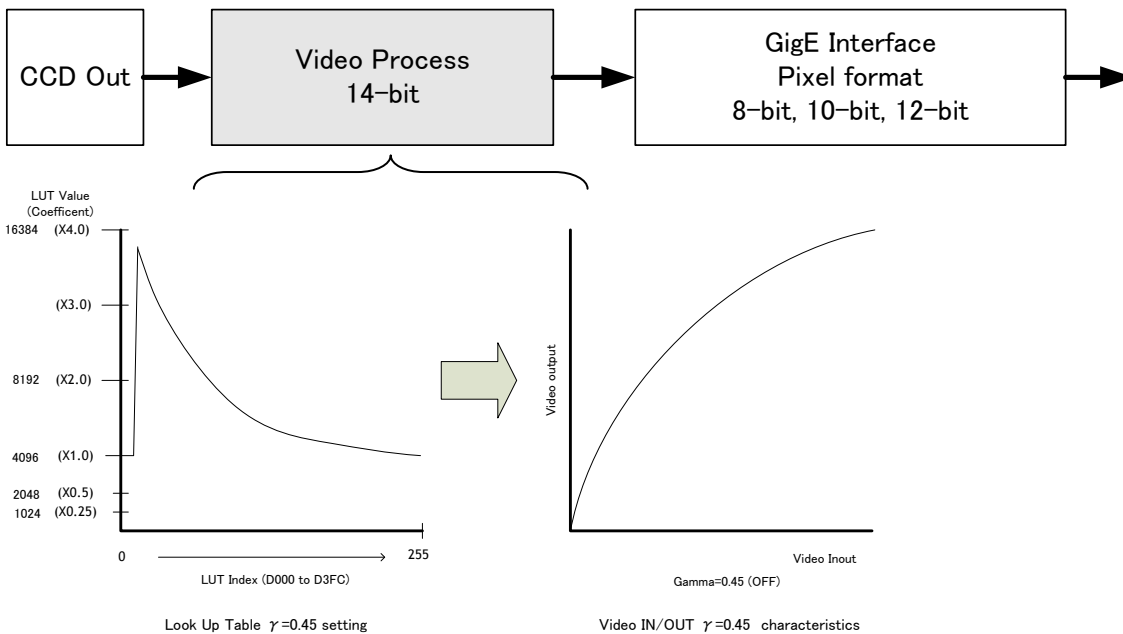

Fig.28 Setting example of Gamma=0.45

BM-141GE / BB-141GE

The Gamma setting and LUT cannot be used at the same time. This is because the Gamma setting and LUT use the same data table.

Gamma setting

Analog Control	
Gain Selector	Analog All
Gain Raw	0
Gain Auto	Off
Gain Auto Balance Once	Push to Execute Command ---->
AGC Reference	2816
Black Level Selector	All
Black Level Raw	0
Black Level Auto Balance Once	Push to Execute Command ---->
Balance White Auto	Manual or One Push
Balance White Auto Once	Push to Execute Command ---->
AWB Area	Middle
Inquire Status	0
Gamma Correction	0.45
Device Information	
Device Vendor Name	0.45
Device Model Name	0.6

LUT Controls	
LUT Enable	False
LUT Index	0
LUT Value	4096

Note: LUT Enable is False.

When LUT is used, the Gamma setting should be 1.0 (OFF). Then “LUT Enable” is set at “True”.

LUT Controls	
LUT Enable	True
LUT Index	True
LUT Value	False

LUT Controls	
LUT Enable	True
LUT Index	0
LUT Value	4096

10. Operation mode

The BM-141GE and BB-141GE comply with GenICam SFNC (Standard Features Naming Convention) version 1.3 and the acquisition of the image, the trigger functions, the exposure settings and so on are different from those used in early versions of these cameras.

10.1. The functions related to GenICam SFNC 1.3

The following functions are the most affected by SFNC 1.3.

Features - Acquisition and Trigger Control

Acquisition mode

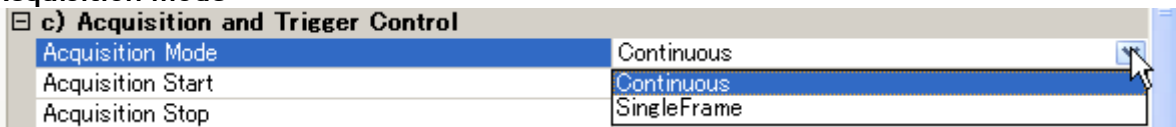

The image can be captured in two ways, continuous or single frame.

- ① Continuous
By executing AcquisitionStart command, the image can be output until AcquisitionStop Trigger is input.
- ② Single Frame
By executing AcquisitionStart command, one frame of the image can be output and then the acquisition is stopped.

Trigger Selector



This can be selected from FrameStart or TransferStart.

- ① FrameStart
The trigger pulse can take one frame capture.
- ② TransferStart
The trigger pulse can read out the image stored in the frame memory. This is used for the delayed Readout

TriggerMode

This selects either trigger mode (ON) or continuous mode (OFF).

TriggerSoftware

This is one of the trigger sources which enables trigger commands to be created using software. In order to use TriggerSoftware, TriggerSource should be set at Software.

TriggerSource

The trigger source can be selected from the following signals.

BM-141GE / BB-141GE

Trigger Source*	Line5 - Optical In 1
Trigger Activation*	Line5 - Optical In 1
Trigger Source Inverter	Line6 - Optical In 2
Exposure Mode	Line7 - TTL In
Exposure Time (us)	Line8 - LVDS In
Exposure Time Abs (us)	Software
Exposure Time Raw	Software Trigger 0
Exposure Auto	Software Trigger 1
d) JAI Acquisition and Trigger Control	
JAI Acquisition Frame Rate	Software Trigger 2 / Action 1
JAI Shutter Mode	Software Trigger 3 / Action 2
JAI Preset Shutter	Pulse Generator 0
JAI Exposure Time Raw	Pulse Generator 1
	Action 1
	Action 2
	Not Connected

TriggerActivation

Trigger Activation*	Rising Edge
Trigger Source Inverter	Rising Edge
Exposure Mode	Falling Edge

This can set how the trigger is activated.

- ① RisingEdge: The trigger is effective at the rising edge of the pulse.
- ② FallingEdge: The trigger is effective at the falling edge of the pulse.

ExposureMode

Exposure Mode	Timed
Exposure Time (us)	Timed
Exposure Time Abs (us)	Trigger Width

This can select the exposure mode.

- ① Timed: The exposure is set in units of μ seconds or lines.
- ② TriggerWidth: The exposure is the same as the trigger width.

The BM-141GE and BB-141GE have a JAI Acquisition and Trigger Control function which is the same as used for previous models and includes 6 types of exposure modes.

JAI Exposure Mode	Continuous trigger
e) Analog Control	
Gain Selector	Continuous trigger
Gain Auto	Edge pre-select
AGC Reference	Pulse-width control
Black Level (Raw)	Reset continuous
JAI Auto Balance Status	Smearless Edge pre-select
Gamma Correction	Sequential EPS trigger
	Delayed readout EPS trigger
	Delayed readout PWC trigger

Acquisition and Trigger Control and JAI Acquisition and Trigger Control are linked to each other and if the one is set, the setting parameters are reflected in the other.

The following is an example: when JAI Acquisition and Trigger Control is set at EPS, TriggerMode is automatically set ON and ExposureMode is set to Timed.

The exposure time can be set in the JAI Shutter Mode by selecting either lines or microseconds and the setting values are reflected in the same items of Acquisition and Trigger Control.

c) Acquisition and Trigger Control	
Acquisition Mode	Continuous
Acquisition Start	Push to Execute Command ---->
Acquisition Stop	Push to Execute Command ---->
Trigger Selector*	Frame Start
Trigger Mode*	On
Trigger Software*	Push to Execute Command ---->
Trigger Source*	Software
Trigger Activation*	Rising Edge
Trigger Source Inverter	False
Exposure Mode	Timed
Exposure Time (us)	24736.00000
Exposure Time Abs (us)	24736.00000
Exposure Time Raw	773
Pre-dump Mode	Off
d) JAI Acquisition and Trigger Control	
JAI Acquisition Frame Rate	25 fps
JAI Shutter Mode	Programmable Exposure in lines
JAI Preset Shutter	Shutter off
JAI Exposure Time Raw	773
JAI Exposure Time (us)	20720
JAI Exposure Mode	Edge pre-select

Other parameters such as trigger signal should be set in Acquisition and Trigger Control.

10.2 GenICam SFNC Standard Trigger Setup Wizard

If the feature properties has (*), the separate window will be open. The following is an example of the trigger selector. This is an easy way tool to set up the trigger.

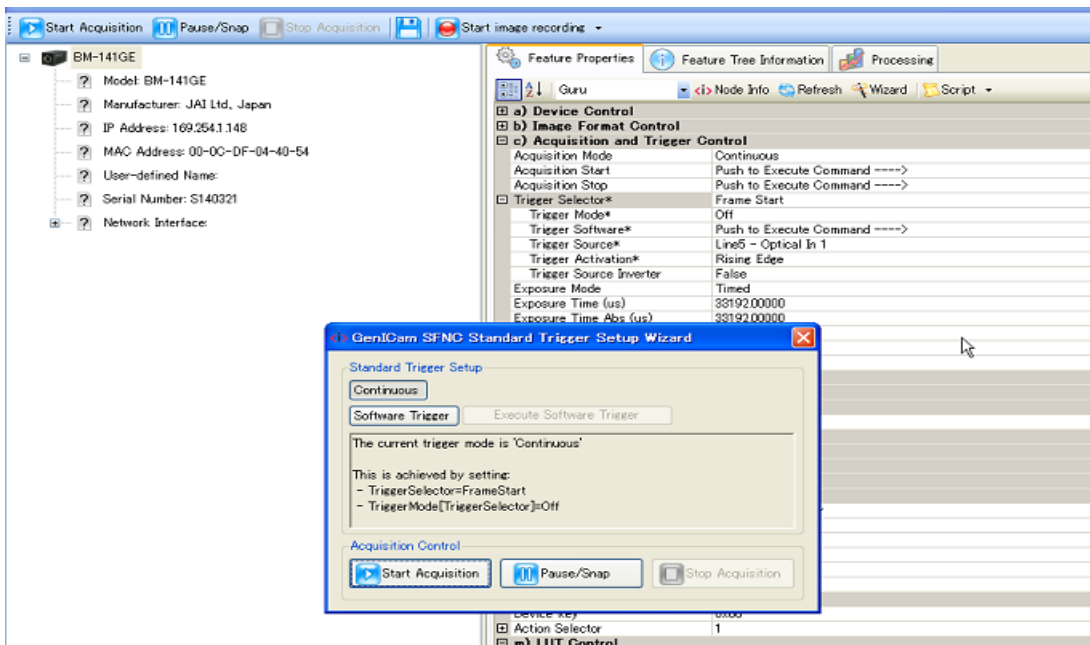

10.3. Operation Modes

This camera can operate in 8 primary modes.

- | | |
|--|----------------------------------|
| 1. Continuous Mode | Pre-selected exposure. |
| 2. Edge Pre-select Mode (EPS) | Pre-selected exposure. |
| 3. Pulse Width Control Mode (PWC) | Pulse width controlled exposure. |
| 4. Reset Continuous Trigger Mode(RCT) | Pre-select exposure |
| 5. Sequential EPS Trigger | Pre-selected exposure (EPS) |
| 6. Delayed Readout EPS Trigger | Pre-selected exposure (EPS) |
| 7. Delayed Readout PWC Trigger | Pulse width controlled exposure |

The following description uses JAI Acquisition and Trigger Control and the operation mode can be selected in JAI Exposure Mode.

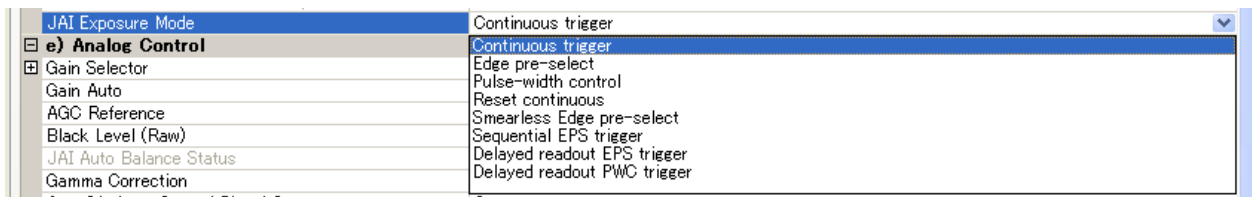

10.3.1 Continuous operation

For applications not requiring asynchronous external triggering, this mode should be used.

In continuous mode it is possible to use a lens with video controlled iris.

For timing details, refer to fig. 19. through fig. 24.

To use this mode:

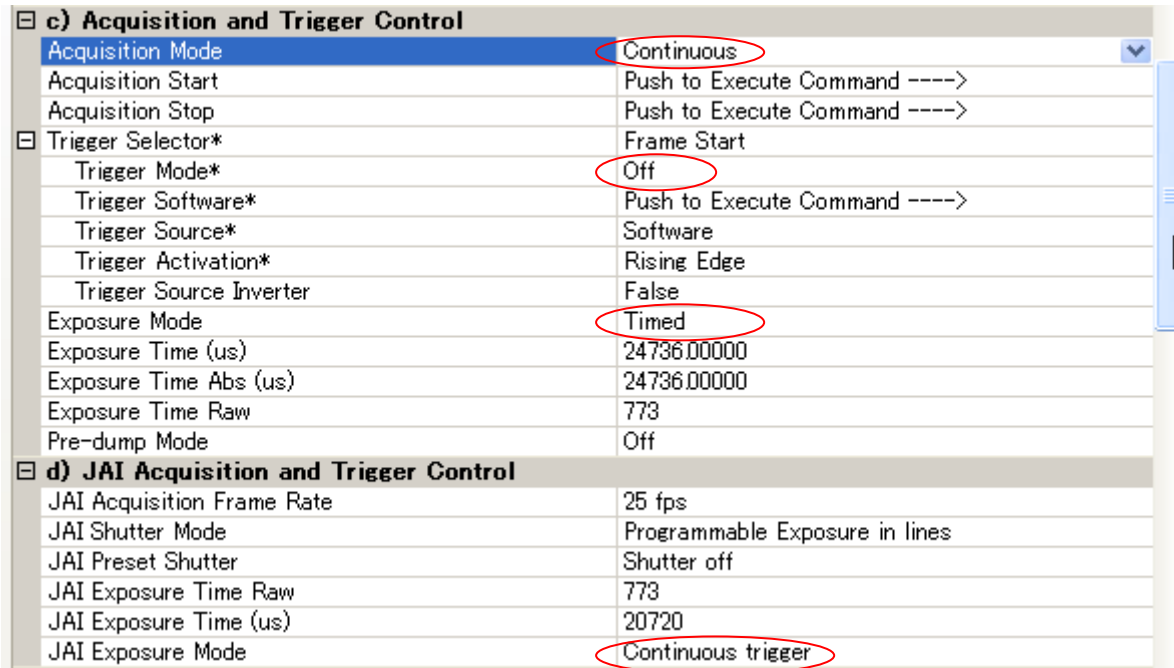

10.3.2 Edge Pre-select (EPS) Trigger Mode

An external trigger pulse initiates the capture, and the exposure time (accumulation time) is the fixed shutter speed set by registers. The accumulation can be LVAL synchronous or LVAL asynchronous. The resulting video signal will start to be read out after the selected shutter time.

For timing details, refer to fig. 19. through fig.24 and figures 29 and 30.

To use this mode:

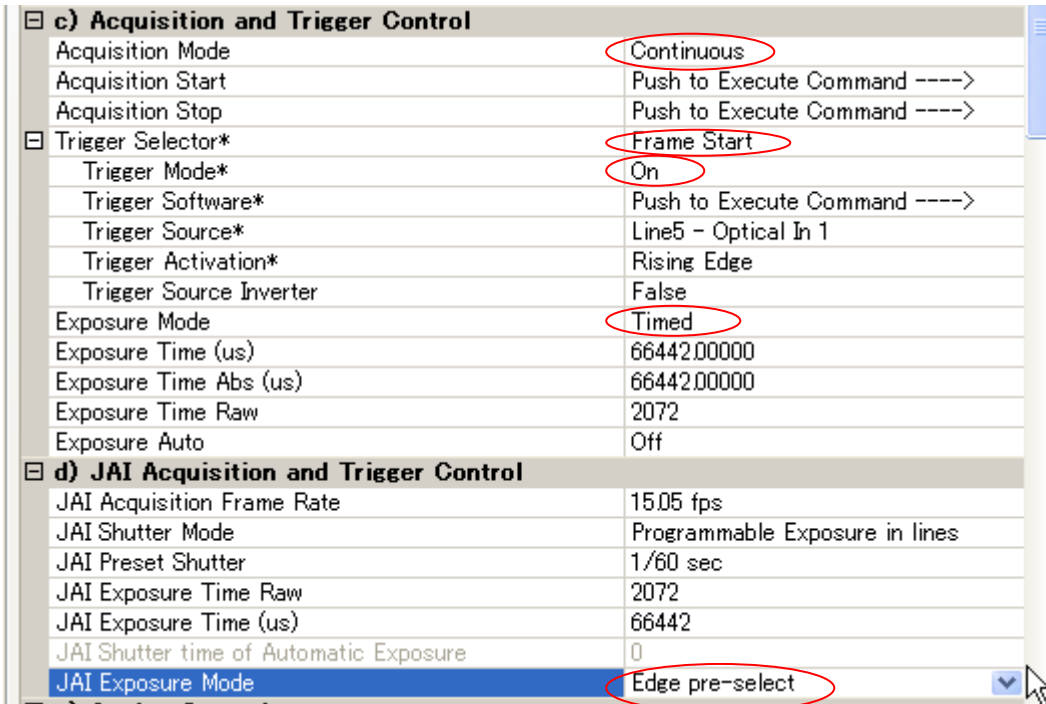

Important notes on using this mode

- Trigger pulse >2 LVAL to <1 FVAL)
- The following table shows minimum trigger interval in synchronous accumulation mode

Full scan	1054 L
2/3 Partial	774 L
1/2 Partial	635L
1/4 Partial	427 L
1/8 Partial	323 L
1/2 V Binning	529 L

In the case of asynchronous mode, the exposure time should be added to the above table.

LVAL_sync timing

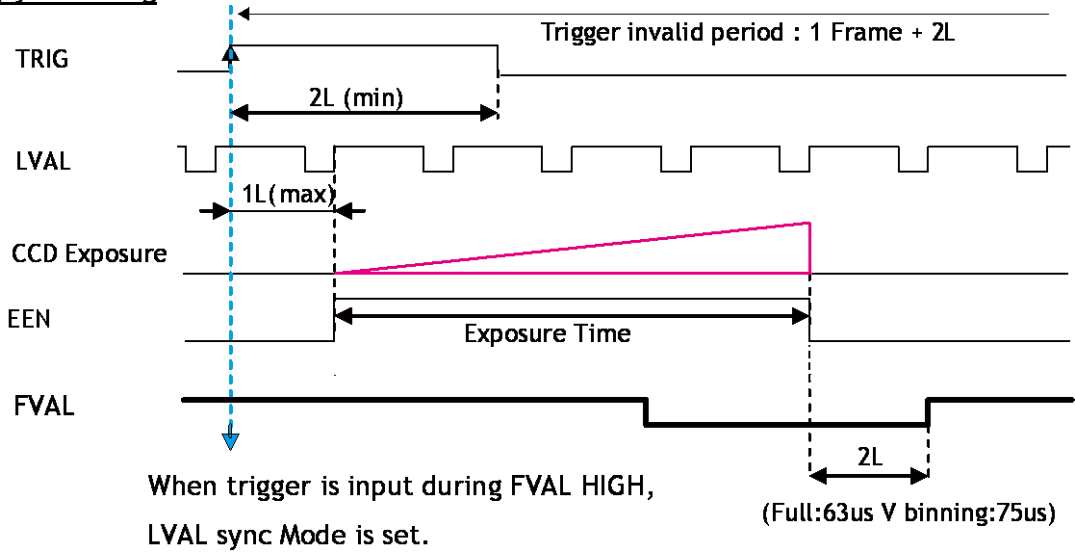

Fig. 28 Edge Pre-select LVAL sync Timing

LVAL_async timing

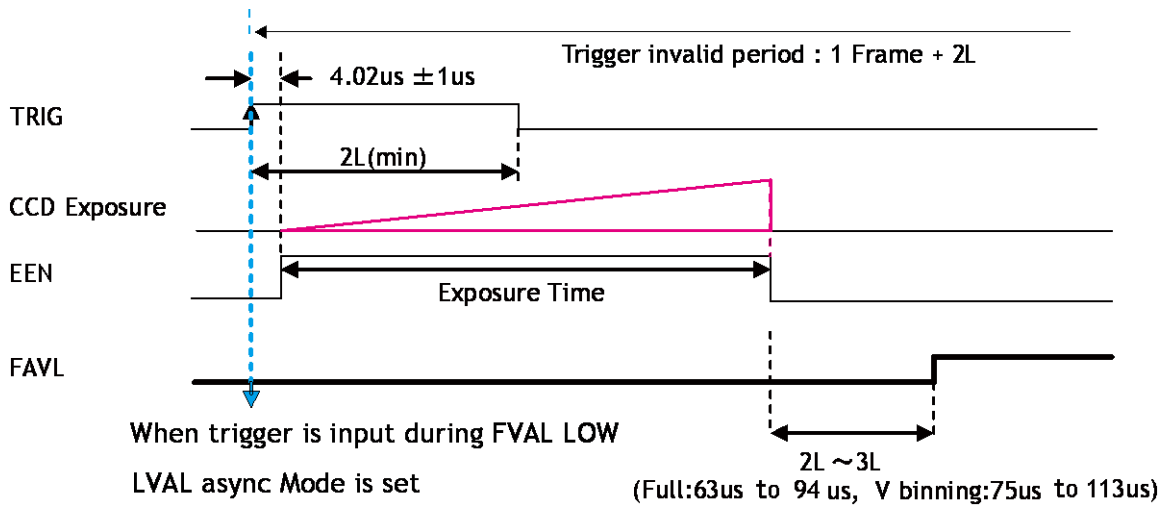

Fig.30 Edge Pre-select LVAL a-sync Timing

10.3.3 Pulse Width Control (PWC) Trigger Mode

In this mode the accumulation time is equal to the trigger pulse width. Here it is possible to have long time exposure. The maximum recommended time is <2 seconds.

The accumulation can be LVAL synchronous or LVAL asynchronous.

The resulting video signal will start to be read out after the trigger rising edge.

For timing details, refer to fig. 21. through fig. 24 and fig.31 and 32.

To use this mode:

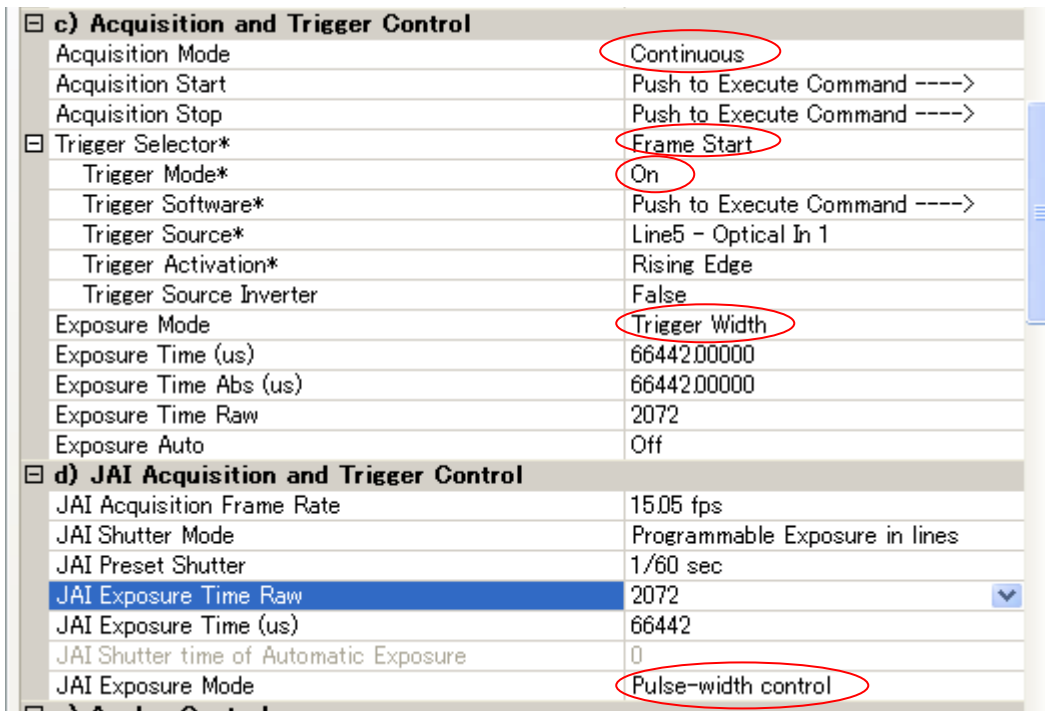

Important notes on using this mode

- Trigger pulse width >2LVAL to <2 seconds
- The following table shows minimum trigger interval in synchronous accumulation mode

Full scan	1054 L
2/3 Partial	774 L
1/2 Partial	635 L
1/4 Partial	427 L
1/8 Partial	323 L
V Binning	529 L

In the case of asynchronous mode, the exposure time should be added to the above table.

LVAL_sync timing

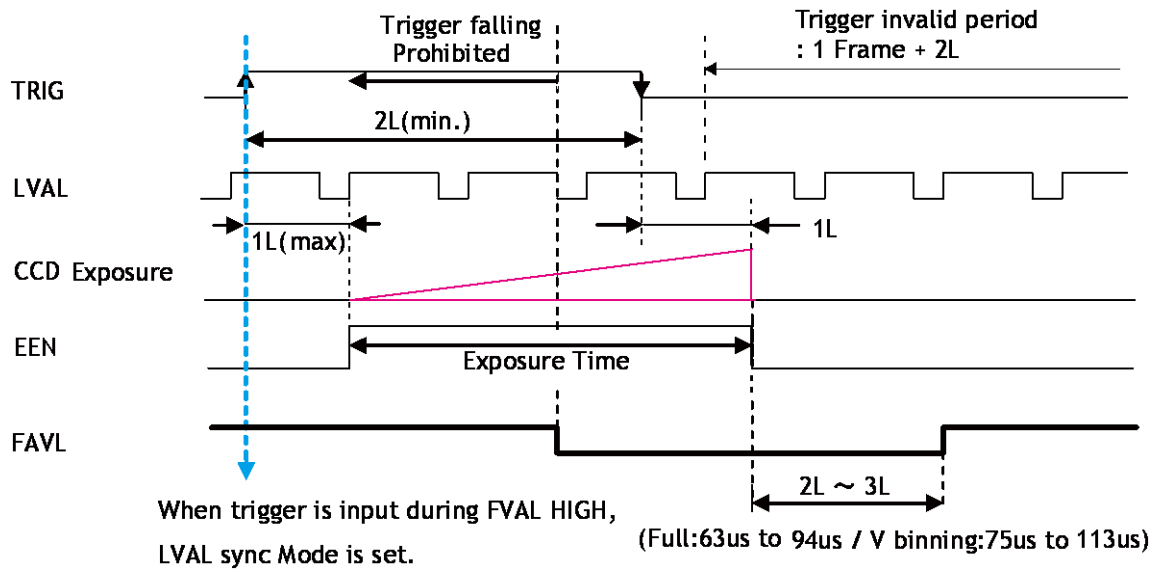

Fig.31 Pulse width control LVAL sync.

LVAL_async timing

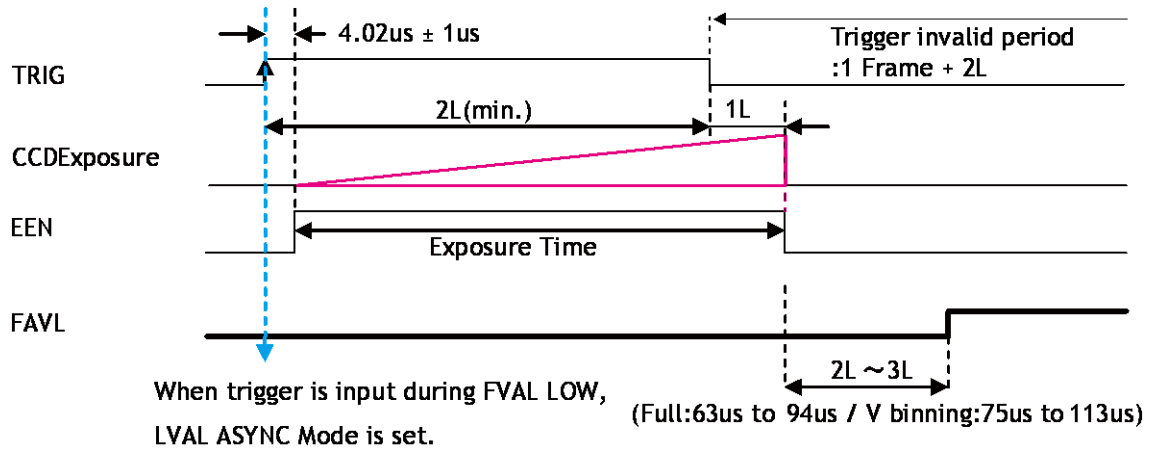

Fig.32 Pulse Width control LVAL a-sync

10.3.4 Auto-detect LVAL-sync / a-sync. accumulation

This function replaces the manual setting found in older JAI cameras. Whether accumulation is synchronous or asynchronous in relationship to LVAL depends on the timing of the trigger input.

When a trigger is received while FVAL is high (during readout), the camera works in LVAL-synchronous mode, preventing reset feed-through in the video signal. There is a maximum jitter of one LVAL period from issuing a trigger and accumulation start.

When a trigger is received while FVAL is low, the camera works in LVAL-asynchronous mode, (no delay) mode.

This applies to both Edge pre-select (EPS) trigger mode and Pulse width trigger (PWC) mode.

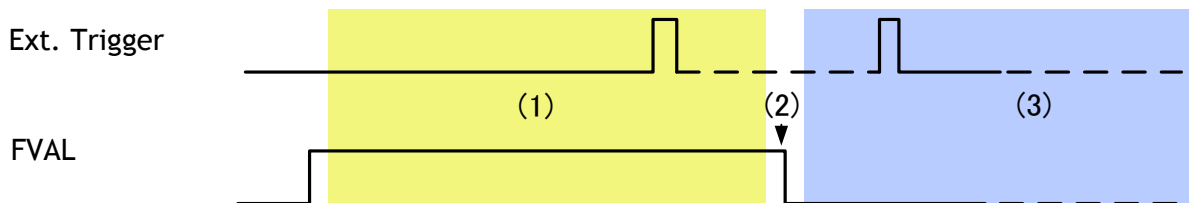

- (1) In this period camera executes trigger at the next LVAL. (Prevents feed-through noise)
- (2) Avoid trigger at FVAL transition (+ / - 1 LVAL period), as the function may randomly switch between “next” and “immediate”.
- (3) In this period camera executes trigger immediately. (No delay)

Fig. 33. Auto-detect LVAL sync / a-sync accumulation

10.3.5 Reset Continuous (RCT) trigger mode

The RCT mode operates like EPS(Edge Preselect)mode with Smearless function. An external trigger pulse will immediately stop the video read out, reset and restart the exposure, then operate as normal mode until the next trigger. After the trigger pulse is input, a fast dump read out is performed. In the BM-141GE and BB-141GE, this period is 6.77ms which is 215L. The exposure time is determined by the pre-set shutter speed. If no further trigger pulses are applied, the camera will continue in normal mode and the video signal is not output. The fast dump read out has the same effect as “smearless read out”. Smear over highlight areas is reduced for the trigger frame. The reset continuous trigger mode makes it possible to use triggering in conjunction with a lens with video controlled iris.

To use this mode:

To use this mode:

There are two ways to set RCT mode..

- ①. Set Exposure Mode to Timed

Then , set Pre-dump mode to ON.

Note: the setting order should be mentioned the above.

- ②. Set JAI Exposure mode to Reset continuous

BM-141GE / BB-141GE

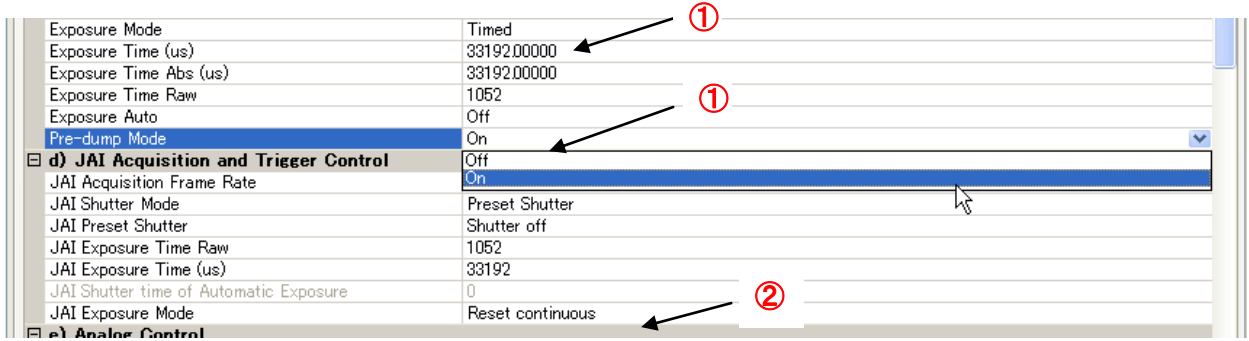

Important notes on using this mode

- Trigger pulse >2 LVAL to <1 FVAL
- The following table shows minimum trigger interval in synchronous accumulation mode

Full scan	1268 L
2/3 Partial	989 L
1/2 Partial	850 L
1/4 Partial	642 L
1/8 Partial	438 L
1/2 V Binning	744 L

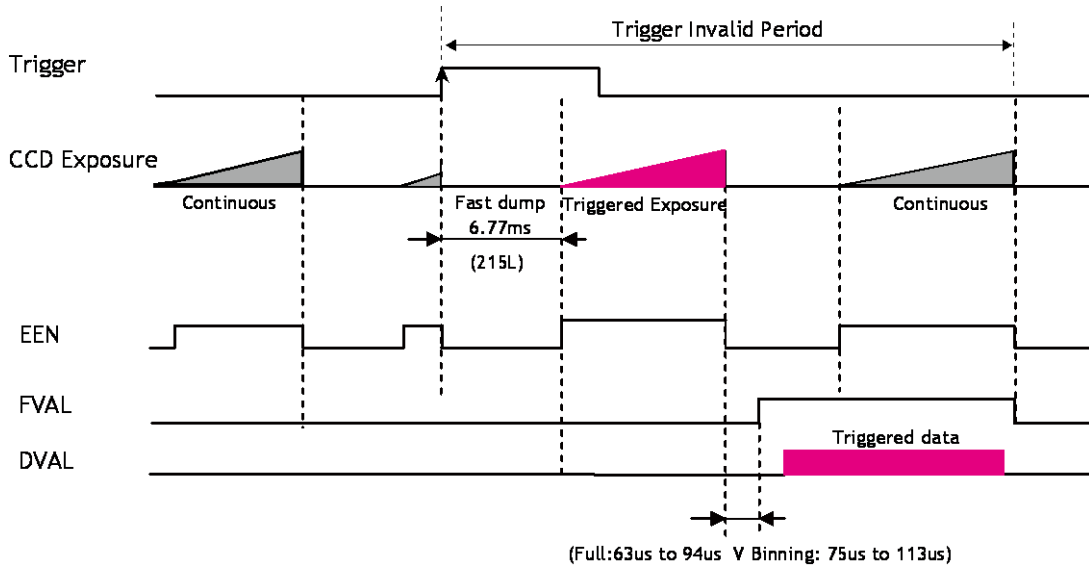

Fig.34 RCT mode timing

10.3.6 Sequential Trigger Mode (EPS)

This mode allows the user to define a preset sequence of up to 10 images, each with its own ROI, Shutter and Gain values. As each trigger input is received, the image data with the preset sequence is output as described below.

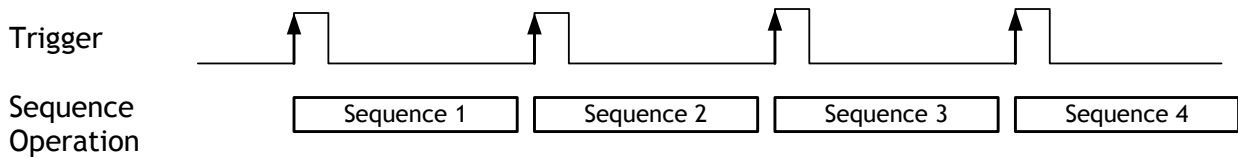

Fig.35 Sequential Trigger Mode

Signals added to a trigger can be selected by 0xB060 Camera Trigger Selector in the register map via GPIO. The camera will function on the rising edge of the trigger and Negative or Positive should be determined accordingly.

The following default settings can be modified by the user to define a sequence.

ID	ROI				Shutter	Gain
	Width	Height	Offset X	Offset Y		
1	1392	1040	0	0	1052	0
2	1392	1040	0	0	1052	0
3	1392	1040	0	0	1052	0
4	1392	1040	0	0	1052	0
5	1392	1040	0	0	1052	0
6	1392	1040	0	0	1052	0
7	1392	1040	0	0	1052	0
8	1392	1040	0	0	1052	0
9	1392	1040	0	0	1052	0
10	1392	1040	0	0	1052	0

In case of sequence EPS (Note: The scree used here is BM/BB-500GE)

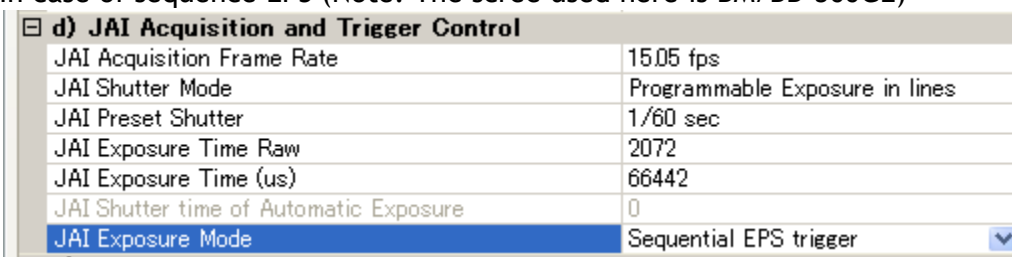

BM-141GE / BB-141GE

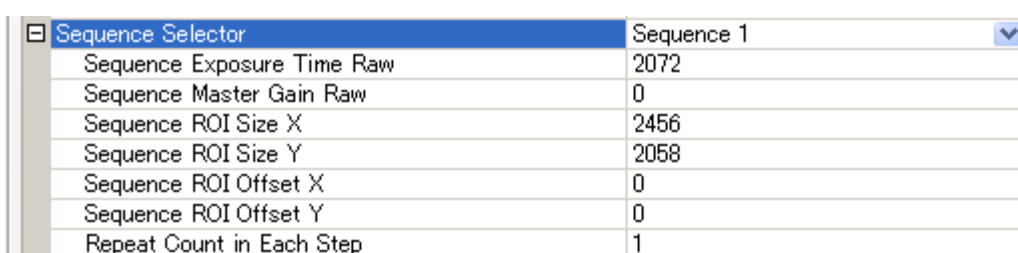
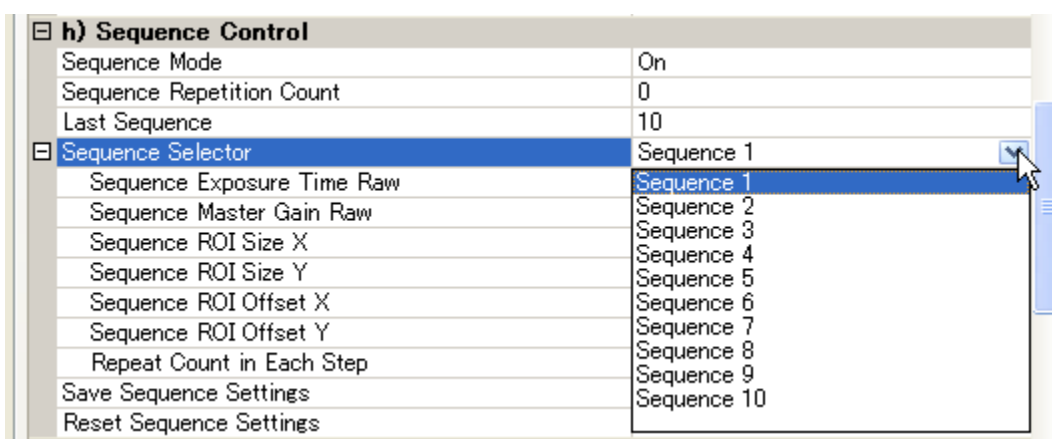

The following table shows the minimum trigger interval in synchronous accumulation mode. In case of asynchronous accumulation mode, the exposure time should be added to figures in this table.

Full Scan	2/3 Partial	1/2 Partial	1/4 Partial	1/8 Partial	1/2 V Binning
1054 L	774 L	635 L	427 L	323 L	529 L

- ◆ The conditions for this table are that shutter speed should be set the same for all sequences. If the shutter speed is different, the difference of exposure time should be added.
- ◆ It is recommended to set the exposure time in the order from the shortest to the longer one.
- ◆ The above table shows the interval at PE=2 (minimum). In case of the longer exposure, the interval is (Value on the table - 2) + Exposure lines.
- ◆ Do not input the trigger just after the sequence is reset. It requires at least 500ms delay.
- ◆ ROI can be set by 8 pixels unit in horizontal way. In vertical way, 1 line for B<-500GE and 2lines for BB-141GE can be set for ROI.

10.3.7 Delayed Readout EPS and PWC Modes (EPS and PWC)

This mode can be used to delay the transmission of a captured image. When several cameras are triggered simultaneously and connected to the same GigE interface, it allows the cameras to be read out in sequence, preventing congestion.

The image data is not transmitted directly by the trigger 0 and is stored in the memory located at Ethernet Interface. By the falling edge of the soft trigger 1, the image data is output.

This mode can work in EPS mode and PWC mode.

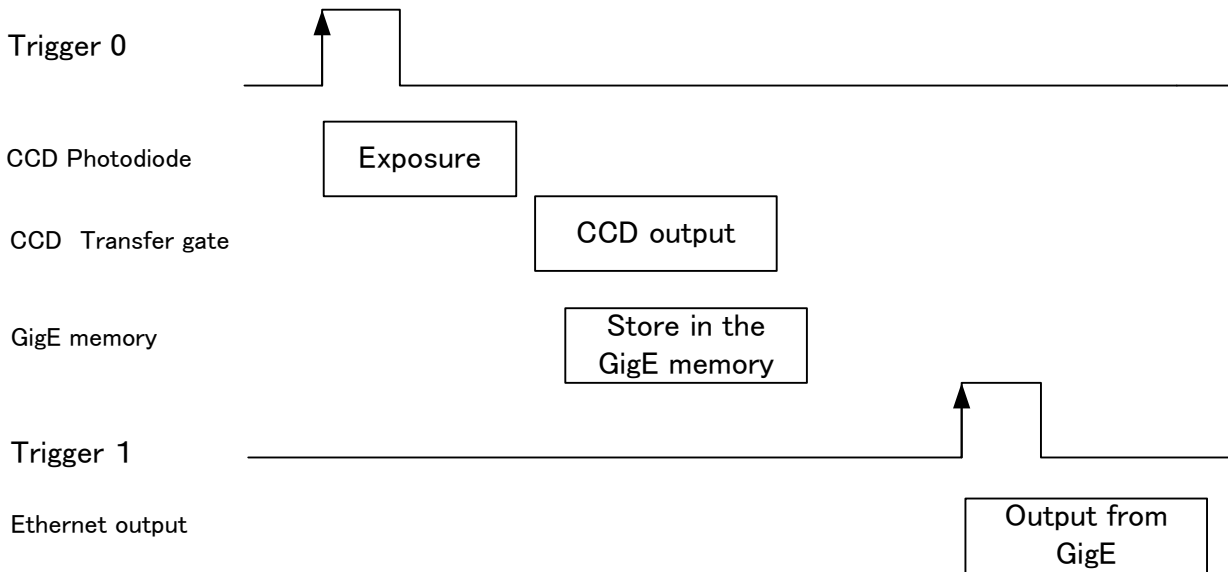

Fig.36 Delayed Read Out Mode

Example of setting

The setting of acquisition(Trigger)

c) Acquisition and Trigger Control	
Acquisition Mode	Continuous
Acquisition Start	Push to Execute Command ---->
Acquisition Stop	Push to Execute Command ---->
Trigger Selector*	
Trigger Mode*	Frame Start
Trigger Software*	On
Trigger Source*	Push to Execute Command ---->
Trigger Source*	Line5 - Optical In 1
Trigger Activation*	Rising Edge
Trigger Source Inverter	False
Exposure Mode	Timed
Exposure Time (us)	66442.00000
Exposure Time Abs (us)	66442.00000
Exposure Time Raw	2072
Exposure Auto	Off
d) JAI Acquisition and Trigger Control	
JAI Acquisition Frame Rate	15.05 fps
JAI Shutter Mode	Programmable Exposure in lines
JAI Preset Shutter	1/60 sec
JAI Exposure Time Raw	2072
JAI Exposure Time (us)	66442
JAI Shutter time of Automatic Exposure	0
JAI Exposure Mode	Delayed readout EPS trigger

The setting for transfer the stored image.

In order to transfer the image, the trigger selector should be set to Transfer start and the related trigger setting is required.

Trigger Selector*	
Trigger Mode*	Transfer Start
Trigger Software*	Frame Start
Trigger Software*	Transfer Start

BM-141GE / BB-141GE

10.3.8 Optical Black transfer Mode

It is possible for the user to decide whether the optical black (OB) portion of the image will be transferred or not. The optical black part can be used for black reference in the application software. Setting register 0xA41C turns the optical black transfer ON or OFF. The default condition is OFF.

	OB Transfer Mode OFF	OB Transfer Mode ON
Normal Scan	<div style="display: flex; justify-content: space-between; align-items: center;"> 1 1392 </div> <div style="display: flex; justify-content: space-between; align-items: center;"> 1 1040 </div>	<div style="display: flex; justify-content: space-between; align-items: center;"> 1 1392 1408 </div> <div style="display: flex; justify-content: space-between; align-items: center;"> 1 1044 </div>
2/3 Partial Scan	<div style="display: flex; justify-content: space-between; align-items: center;"> 1 1392 </div> <div style="display: flex; justify-content: space-between; align-items: center;"> 1 694 </div>	<div style="display: flex; justify-content: space-between; align-items: center;"> 1 1392 1408 </div> <div style="display: flex; justify-content: space-between; align-items: center;"> 1 694 </div>
1/2 Partial Scan	<div style="display: flex; justify-content: space-between; align-items: center;"> 1 1392 </div> <div style="display: flex; justify-content: space-between; align-items: center;"> 1 520 </div>	<div style="display: flex; justify-content: space-between; align-items: center;"> 1 1392 1408 </div> <div style="display: flex; justify-content: space-between; align-items: center;"> 1 520 </div>
1/4 Partial Scan	<div style="display: flex; justify-content: space-between; align-items: center;"> 1 1392 </div> <div style="display: flex; justify-content: space-between; align-items: center;"> 1 260 </div>	<div style="display: flex; justify-content: space-between; align-items: center;"> 1 1392 1408 </div> <div style="display: flex; justify-content: space-between; align-items: center;"> 1 260 </div>
1/8 Partial Scan	<div style="display: flex; justify-content: space-between; align-items: center;"> 1 1392 </div> <div style="display: flex; justify-content: space-between; align-items: center;"> 1 130 </div>	<div style="display: flex; justify-content: space-between; align-items: center;"> 1 1392 1408 </div> <div style="display: flex; justify-content: space-between; align-items: center;"> 1 130 </div>
V Binning Scan	<div style="display: flex; justify-content: space-between; align-items: center;"> 1 1392 </div> <div style="display: flex; justify-content: space-between; align-items: center;"> 1 520 </div>	<div style="display: flex; justify-content: space-between; align-items: center;"> 1 1392 1408 </div> <div style="display: flex; justify-content: space-between; align-items: center;"> 1 520 </div>

Note: The menu for ON or OFF of OB transfer mode is found on the Image Format Control of JAI SDK Camera Control Tool.

Image Format Control	
Sensor Width	1392
Sensor Height	1040
Width Max	1392
Height Max	1040
Width	1392
Height	1038
Offset X	0
Offset Y	1
Line Pitch	1392
Partial Scan	Full Frame
Pixel Format	8 Bit BAYGB
Test Image Selector	Off
OB Transfer Mode	Off
Pulse Generators	
Clock Source	On

10.3.9 Multi ROI mode (Multi Region of Interest)

In the trigger mode, the maximum 5 ROIs located on the one image can be output by one trigger input. By using this mode, the data stream can be smaller. Each ROI can be overlapped.

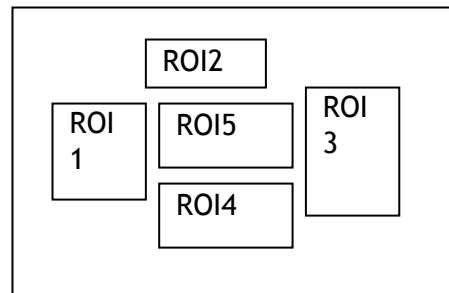

10.4. Operation Mode and Functions matrix

Mode	Shutter Preset / Program.	Vertical Binning (Note 1)	Partial Scanning	DRAFT	Multi ROI	LVAL Sync/ Async	Auto Iris output (Note 2)
Continuous	Yes	Yes	Yes	Yes	No	---	Yes
Edge Pre-select (PS)	Yes	Yes	Yes	No	Yes	Auto	No
Pulse Width Control (PW)	Not applicable	Yes	Yes	No	Yes	Auto	No
RCT	Yes	Yes	Yes	No	Yes	Async	Yes
Sequential EPS	Yes	Yes	Yes	No	No	Async	No
Delayed Readout EPS	Yes	Yes	Yes	No	Yes	Auto	No
Delayed Readout PWC	Yes	Yes	Yes	No	Yes	Auto	No

Note 1: Vertical Binning is available only for BM-141GE.

Note 2: The Auto iris output is only effective on Normal scan and Vertical binning modes. It is not available on the partial scan mode.

11. JAI control tool

In this section, the general operation of the JAI control tool is explained. For more details regarding the JAI control tool, please refer to the JAI control tool documentation provided in the JAI SDK.

11.1. About GenICam™SFNC1.3

The BM-141GE and BB-141GE are now redesigned as conforming to GenICam SFNC1.3. GenICam SFNC stands for GenICam Standard Features Naming Convention. By defining the standard cases and the standard features, general-purpose software can control cameras from any manufacturers which conform to the GenICam standard.

Terminologies used for functions will be much different from previous models. This manual explains the basic operation using feature names specified in the GenICam SFNC 1.3 specification.

The latest version of JAI GigE Vision cameras comply with GenICam SFNC1.3. However, JAI can offer the following options for customers who use older versions of GigE Vision cameras.

JAI provides the following software.

1. Version prior to SFNC 1.3 for older camera version
2. Downgrade to old version from the latest SFNC 1.3 version

Please contact local sales representatives for the details

11.2. JAI SDK Ver. 1.3

JAI SDK has also been upgraded to version 1.3.

In a GigE Vision compliant camera, all features are described in the XML file inside the camera and after connecting JAI Control Tool software, all features are downloaded to the JAI Control Tool software. If customers use older versions of cameras together with the Control Tool software ver.1.3, feature properties shown in the Control Tool exhibit old feature names, enabling customers to operate cameras in a familiar way.

If the latest version of the camera is connected, some traditional JAI feature names such as JAI Preset Shutter, will display in the Feature Properties in addition to the newer GenICam SFNC 1.3 names.

These features can be set as usual and settings for those features are reflected automatically in the GenICam SFNC 1.3 feature names.

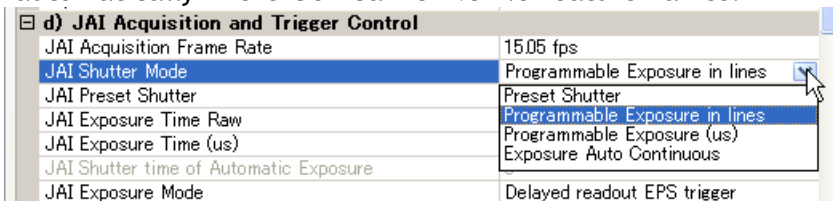

d) JAI Acquisition and Trigger Control	
JAI Acquisition Frame Rate	15.05 fps
JAI Shutter Mode	Programmable Exposure in lines
JAI Preset Shutter	Preset Shutter
JAI Exposure Time Raw	Programmable Exposure in lines
JAI Exposure Time (us)	Programmable Exposure (us)
JAI Shutter time of Automatic Exposure	Exposure Auto Continuous
JAI Exposure Mode	Delayed readout EPS trigger

The features shown above will vary depending on the specific camera.

11.3. Examples of camera operation

The following descriptions are based on GenICam SFNC 1.3.

11.3.1 Generic cautions for operation

1. The parameters in the gray part of the control tool cannot be changed.
2. If the image size is changed, the acquisition should be stopped and parameters set for determining the size.

11.3.2 Connection of camera(s)

Connect camera(s) to Network. After establishing the connection, start the control tool. The model name connected to the Network is displayed with connecting icon.



When this icon is double-clicked, the camera can communicate with the camera control tool and the icon is changed.

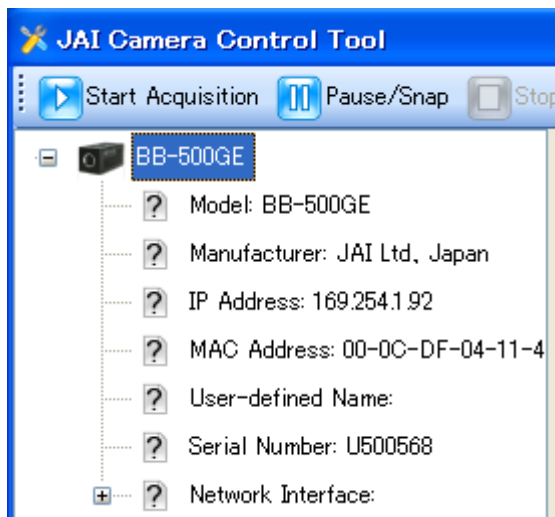
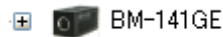

11.3.3 Camera setting level

The setting level has three layers: beginner, expert and guru. Guru level includes the most sophisticated functions.

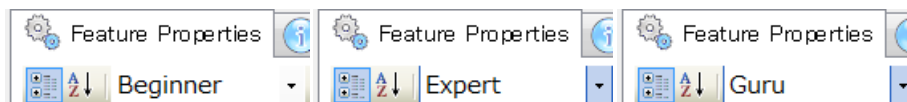

11.4. Input and Output settings

11.4.1 Interfacing with external devices

For interfacing with external devices, the relationship between Line in/out (Digital I/O) and the external terminal is fixed. Please refer to エラー! 参照元が見つかりません。

BM-141GE / BB-141GE

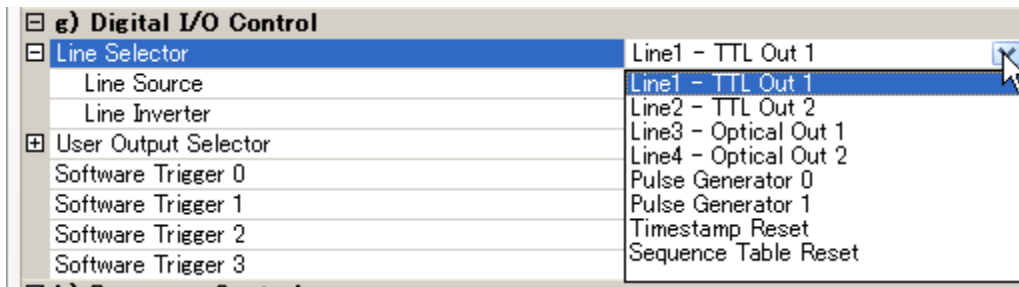

In the camera control tool, it is displayed as Line 1 -TTL Out1.

11.4.2 Setting of input and output

11.4.2.1 How to assign the signal to Line

This function decides which signal is assigned to Digital I/O (Line 1 to Line 8).

The following is the example to set Line5 - Opt In 1. In this case, the line source is the signal connected to Opt In 1. The line format is automatically set to Opto Coupled.

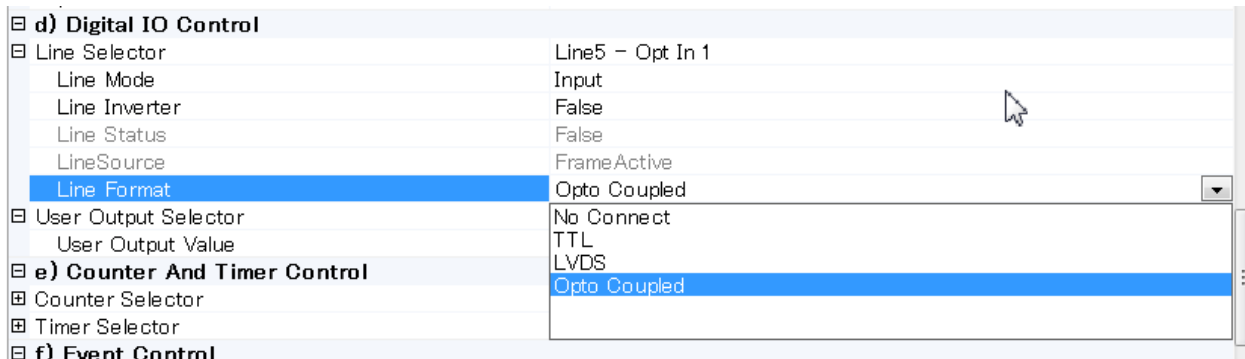

The following is the example to set the output signal. It selects the output signal from Line3 - Optical Out 1 from Line source. In the following example, Exposure Active signal is output. As the line format, TTL is automatically selected.

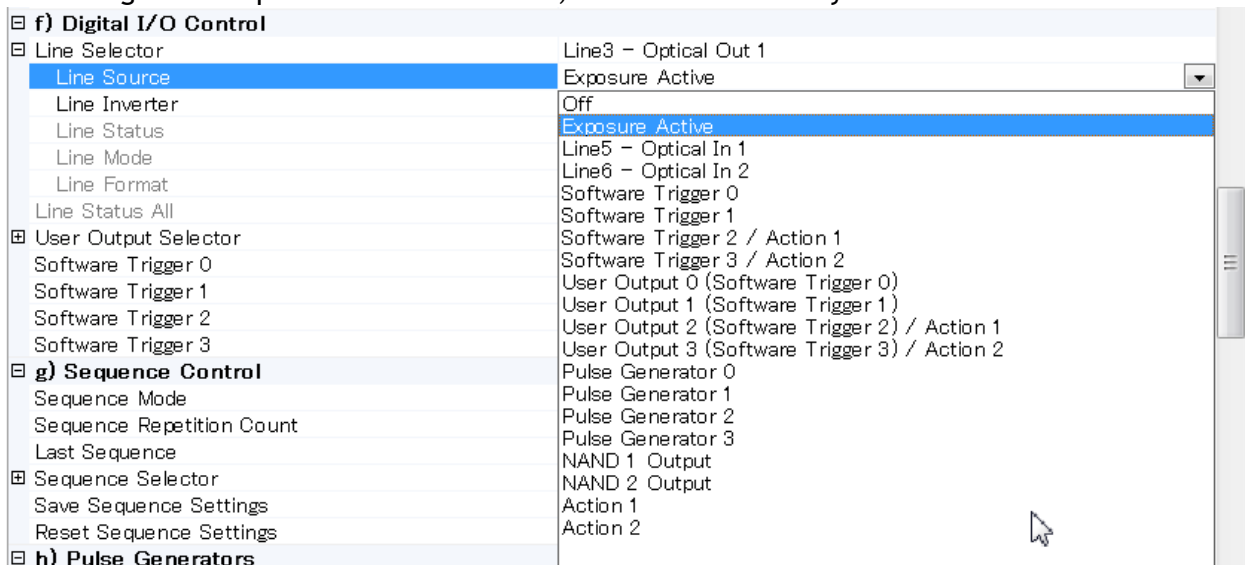

11.4.2.2 Selecting of Trigger Source

The trigger signal is chosen by TriggerSource of TriggerSelector in Acquisition Control. In the following example, pulse generator 0 is selected as the trigger signal.

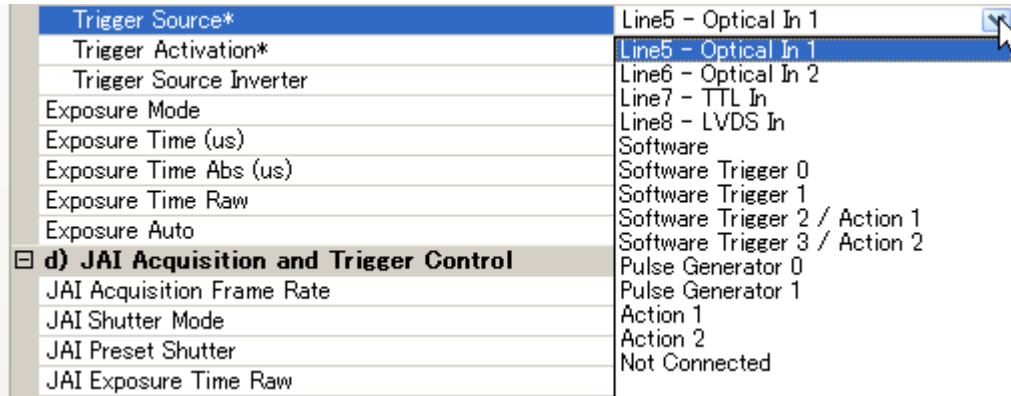

11.4.3 Setting the image size

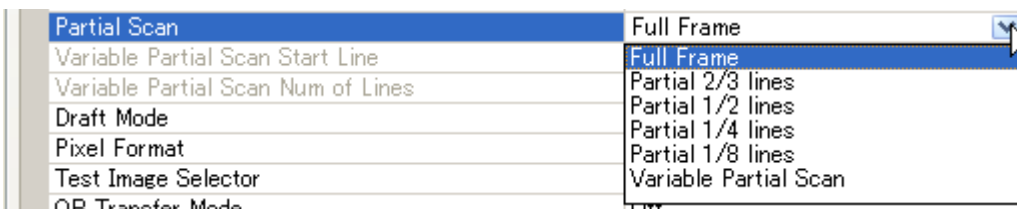

11.4.4 Acquisition of the image

The settings for image capturing are controlled in Acquisition and Trigger Control or JAI Acquisition and Trigger Control. The following shows the screen.

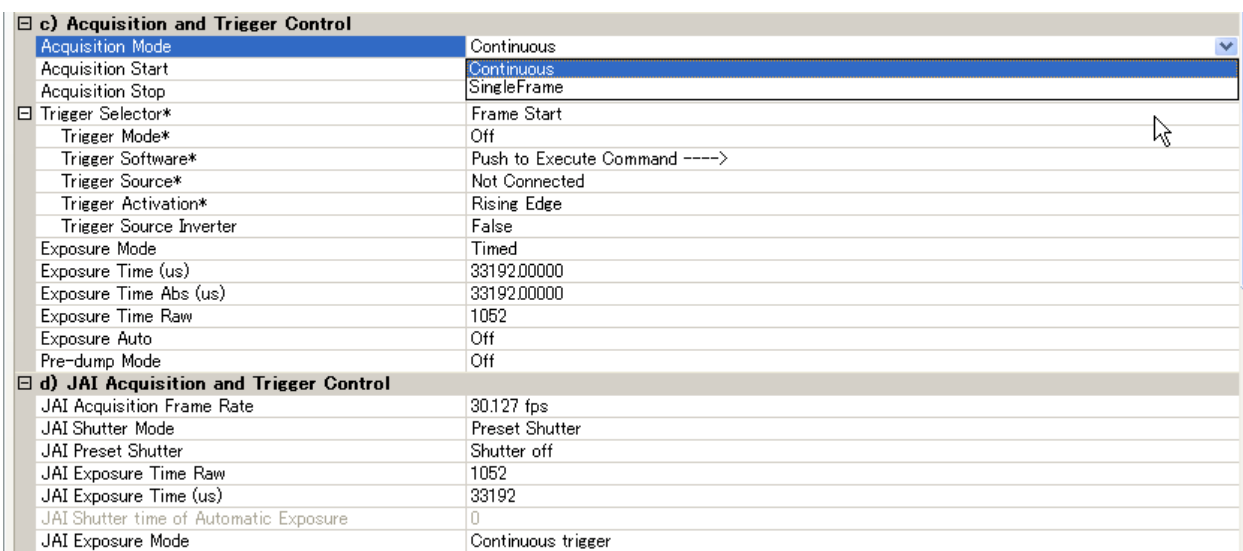

After the setting of capture is completed, push StartAcquisition button. As for the details of each operation mode, refer to 10. Operation Modes.

11.4.5 How to look at XML file

All features and registers of the camera are stored in the camera as an XML file. This XML file is stored in the following folder.

My computer → Local disk (C) → Program files → GenICam_V2.0 → xml → TransportLayers → JAI

11.4.6 Feature Tree Information

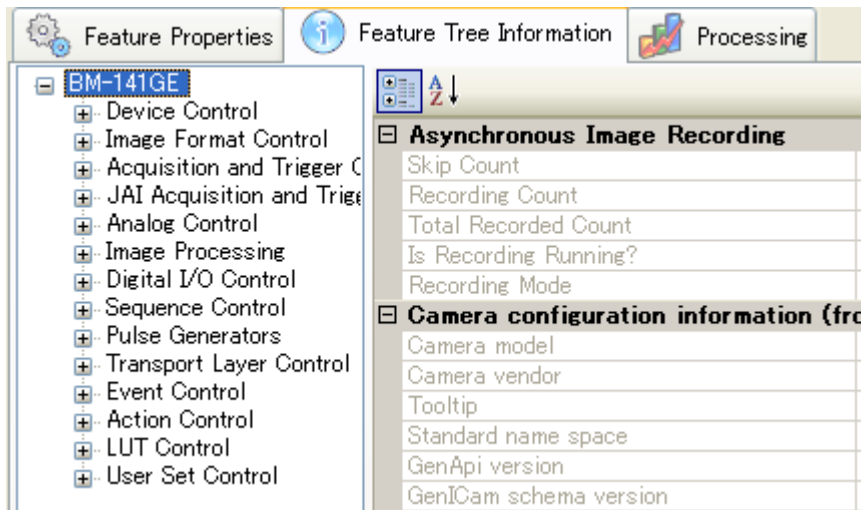

11.4.7 Feature Properties (Guru)

Feature Properties | Feature Tree Information | Processing

Guru | Node Info | Refresh | Wizard | Script

a) Device Control	
Device Vendor Name	JAI Ltd., Japan
Device Model Name	BM-141GE
Device Version	0.1.4.9
FPGA Version	76
Device Manufacturer Info	See the possibilities
Device ID	S140321
Device User ID	
Device Scan Type	Areascan
Device Max Throughput	43430400
Device Reset	Push to Execute Command ---->
b) Image Format Control	
Sensor Width	1408
Sensor Height	1044
Sensor Taps	One
Sensor Digitization Taps	One
Width Max	1392
Height Max	1040
ROI Mode	1
ROI Selector	ROI 1
Width	1392
Height	1040
Offset X	0
Offset Y	0
Line Pitch	1392
Partial Scan	Full Frame
Variable Partial Scan Start Line	1
Variable Partial Scan Num. of Lines	1032
Binning Vertical	1
Pixel Format	8 Bit Monochrome
Test Image Selector	Off
Optical Black Transfer Mode	Off
c) Acquisition and Trigger Control	
Acquisition Mode	Continuous
Acquisition Start	Push to Execute Command ---->
Acquisition Stop	Push to Execute Command ---->
Trigger Selector*	Frame Start
Trigger Mode*	Off
Trigger Software*	Push to Execute Command ---->
Trigger Source*	Not Connected
Trigger Activation*	Rising Edge
Trigger Source Inverter	False
Exposure Mode	Timed
Exposure Time (us)	33192.00000
Exposure Time Abs (us)	33192.00000
Exposure Time Raw	1052
Exposure Auto	Off
Pre-dump Mode	Off

BM-141GE / BB-141GE

Feature Properties		Feature Tree Information		Processing	
Guru		Node Info		Refresh Wizard Script	
d) JAI Acquisition and Trigger Control					
JAI Acquisition Frame Rate		30.127 fps			
JAI Shutter Mode		Preset Shutter			
JAI Preset Shutter		Shutter off			
JAI Exposure Time Raw		1052			
JAI Exposure Time (us)		33192			
JAI Shutter time of Automatic Exposure		0			
JAI Exposure Mode		Continuous trigger			
e) Analog Control					
Gain Selector		Analog All			
Gain (Raw)		0			
Gain Auto		Off			
AGC Reference		2400			
Black Level (Raw)		0			
JAI Auto Balance Status		Completed			
Gamma Correction		1.0			
Auto Iris Lens Control Signal Output		On			
f) Image Processing					
Blemish Reduction		Off			
g) Digital I/O Control					
Line Selector		Line1 - TTL Out 1			
Line Source		Off			
Line Inverter		False			
User Output Selector		User Output 0			
User Output Value		False			
Software Trigger 0		0			
Software Trigger 1		0			
Software Trigger 2		0			
Software Trigger 3		0			
h) Sequence Control					
Sequence Mode		Off			
Sequence Repetition Count		0			
Last Sequence		10			
Sequence Selector		Sequence 1			
Sequence Exposure Time Raw		1052			
Sequence Master Gain Raw		0			
Sequence ROI Size X		1392			
Sequence ROI Size Y		1040			
Sequence ROI Offset X		0			
Sequence ROI Offset Y		0			
Repeat Count in Each Step		1			
Save Sequence Settings		Push to Execute Command ---->			
Reset Sequence Settings		Push to Execute Command ---->			

Feature Properties		Feature Tree Information		Processing	
Guru					
Node Info Refresh Wizard Script					
i) Pulse Generators					
Clock Source		Pixel Clock (58MHz)			
Clock Pre-scaler		1			
Pulse Generator Clock (MHz)		58.00000			
Pulse Generator Selector Pulse Generator 0					
Pulse Generator Length		1			
Pulse Generator Length (ms)		0.00002			
Pulse Generator Frequency (Hz)		58000000.00000			
Pulse Generator Start Point		0			
Pulse Generator Start Point (ms)		0.00000			
Pulse Generator End Point		1			
Pulse Generator End Point (ms)		0.00002			
Pulse Generator pulse-width (ms)		1.7241379310344828E-05			
Pulse Generator Repeat Count		0			
Pulse Generator Clear Activation		Free Run			
Pulse Generator Clear Source		Off			
Pulse Generator Clear Inverter		False			
Clear Mode for the Pulse Generators		Free Run			
j) Transport Layer Control					
Payload Size		1447680			
GigE Vision Major Version		1			
GigE Vision Minor Version		1			
Is Big Endian		True			
Character Set		UTF8			
Interface Selector 0					
MAC Address		00-0C-DF-04-40-54			
Supported LLA		True			
Supported DHCP		True			
Supported Persistent IP		True			
Current IP Configuration LLA		True			
Current IP Configuration DHCP		True			
Current IP Configuration Persistent IP		False			
Current IP Address		169.254.1.148			
Current Subnet Mask		255.255.0.0			
Current Default Gateway		0.0.0.0			
Persistent IP Address		192.168.2.1			
Persistent Subnet Mask		255.255.255.0			
Persistent Default Gateway		0.0.0.0			
GigE Vision Supported Option Selector Link Local Address configuration					
Supported Option		True			
First URL		Local:JAI_BM-141GE_Ver202.zip;243C0000;714E			
Second URL					
Number Of Interfaces		1			
Message Channel Count		1			
Stream Channel Count		1			
Supported Optional Commands EVENTDATA		False			
Supported Optional Commands EVENT		True			
Supported Optional Commands PACKET RESEND		True			
Supported Optional Commands WRITEMEM		True			
Supported Optional Commands Concatenation		True			
Heartbeat Timeout		15000			
Timestamp Tick Frequency		62500000			

BM-141GE / BB-141GE

Timestamp Control Latch	Push to Execute Command ---->
Timestamp Control Reset	Push to Execute Command ---->
Timestamp Tick Value	0
Control Channel Privilege	Control Access
Message Channel Port	2636
Message Channel Destination Address	169.254.181.73
Message Channel Transmission Timeout	300
Message Channel Retry Count	2
Message Channel Source Port	2636
<input type="checkbox"/> Stream Channel Selector	0
Stream Channel Port	0
Fire Test Packet	False
Do Not Fragment	True
Packet Size	1428
Packet Delay*	1070
Stream Channel Destination Address	0.0.0.0
Stream Channel Source Port	0
Event GEV_EVENT_TRIGGER Enabled	False
Event GEV_EVENT_START_OF_EXPOSURE Enabled	False
Event GEV_EVENT_END_OF_EXPOSURE Enabled	False
Event GEV_EVENT_START_OF_TRANSFER Enabled	False
Event GEV_EVENT_END_OF_TRANSFER Enabled	False
<input type="checkbox"/> Inter-Packet Delay Calculator	
Packet Size	1428
Pixel Format	8 Bit Monochrome
Expected Bandwidth Usage (%)	90.00000
Maximum Acquisition Frame-rate (fps)	30.12737
Inter-Packet Delay Estimate	1069
Packet Delay*	1070
<input type="checkbox"/> Intermediate Values	
Number of Packets	1043
Total Image Size (Payload + GVSP overhead)	1504050
Total Image Transmission Time per second (s)	0.3625045186584
Total Pause Time (s)	0.5374954813416
Inter-Packet Delay Time (s)	1.71052468366142E-05

<input type="checkbox"/> k) Event Control	
<input type="checkbox"/> Event Selector	Acquisition Trigger
Event Notification	Off
<input type="checkbox"/> Acquisition Trigger Event Data	
Event ID	
Timestamp	
<input type="checkbox"/> Acquisition Start Event Data	
Event ID	
Timestamp	
<input type="checkbox"/> Acquisition End Event Data	
Event ID	
Timestamp	
<input type="checkbox"/> Exposure Start Event Data	
Event ID	
Timestamp	
<input type="checkbox"/> Exposure End Event Data	
Event ID	
Timestamp	
<input type="checkbox"/> l) Action Control	
Device Key	0x00
<input type="checkbox"/> Action Selector	1
Group Key	0x00
Group Mask	0x00
<input type="checkbox"/> m) LUT Control	
<input type="checkbox"/> LUT Selector	Luminance
LUT Enable	False
<input type="checkbox"/> LUT Index*	0
LUT Value*	4096
<input type="checkbox"/> n) User Set Control	
<input type="checkbox"/> User Set Selector	Factory
User Set Load	Push to Execute Command ---->
User Set Save	Push to Execute Command ---->
Current User Set Selector	Factory

12. External Appearance and Dimensions

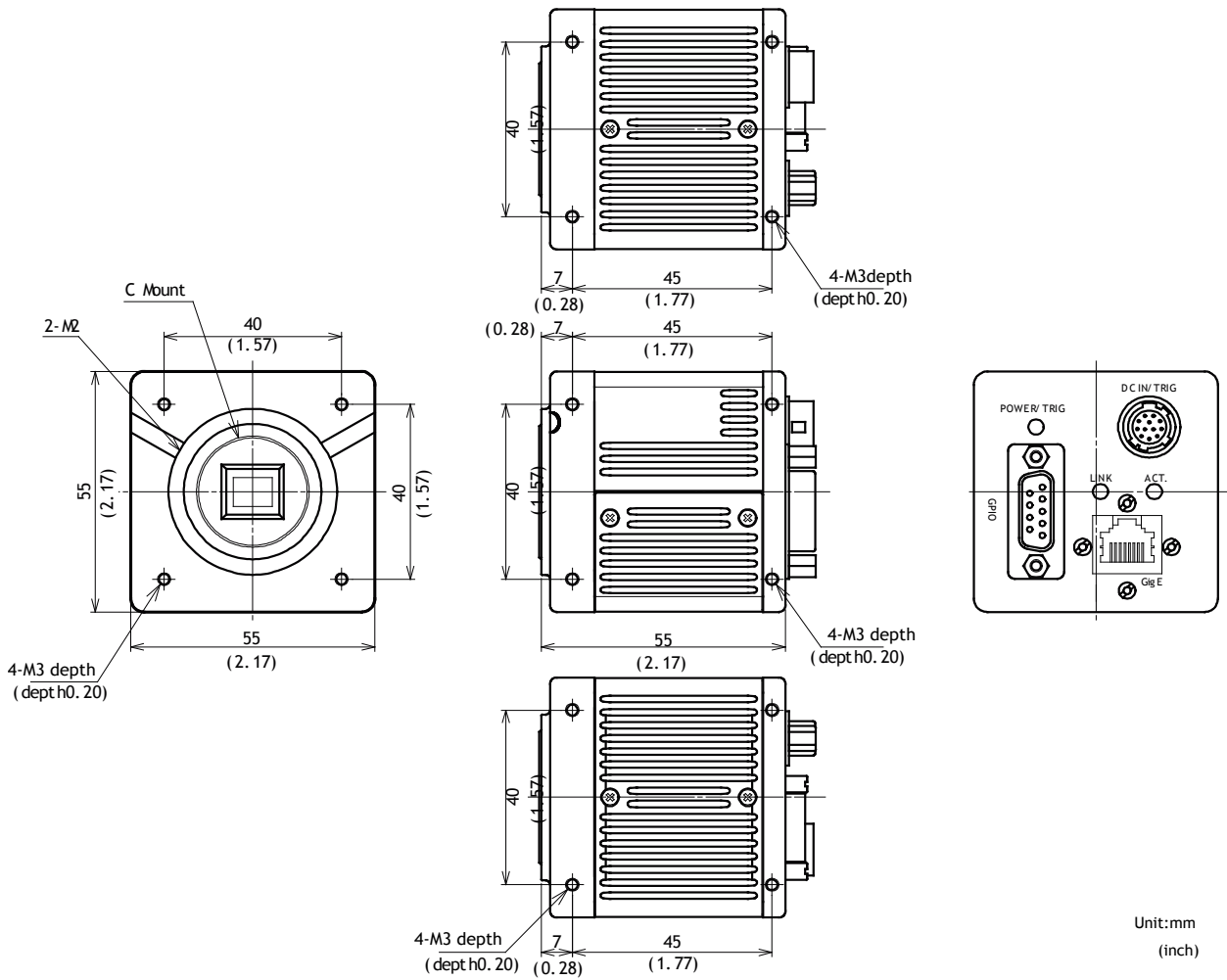

Fig. 37 Outline.

13. Specifications

13.1. Spectral response

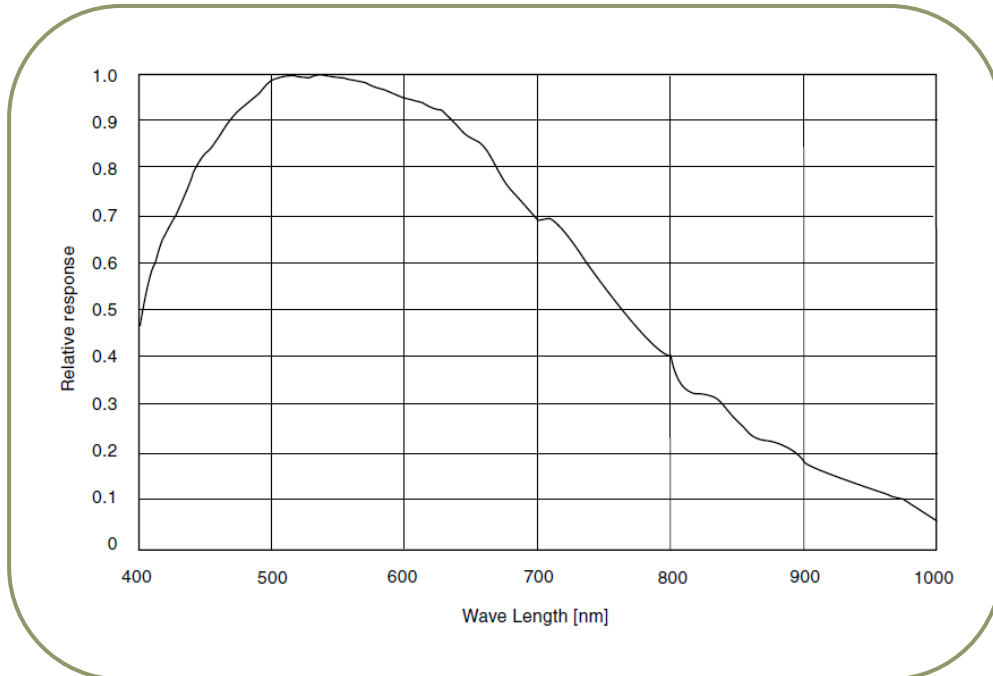

Fig.38 Spectral response for BM-141GE

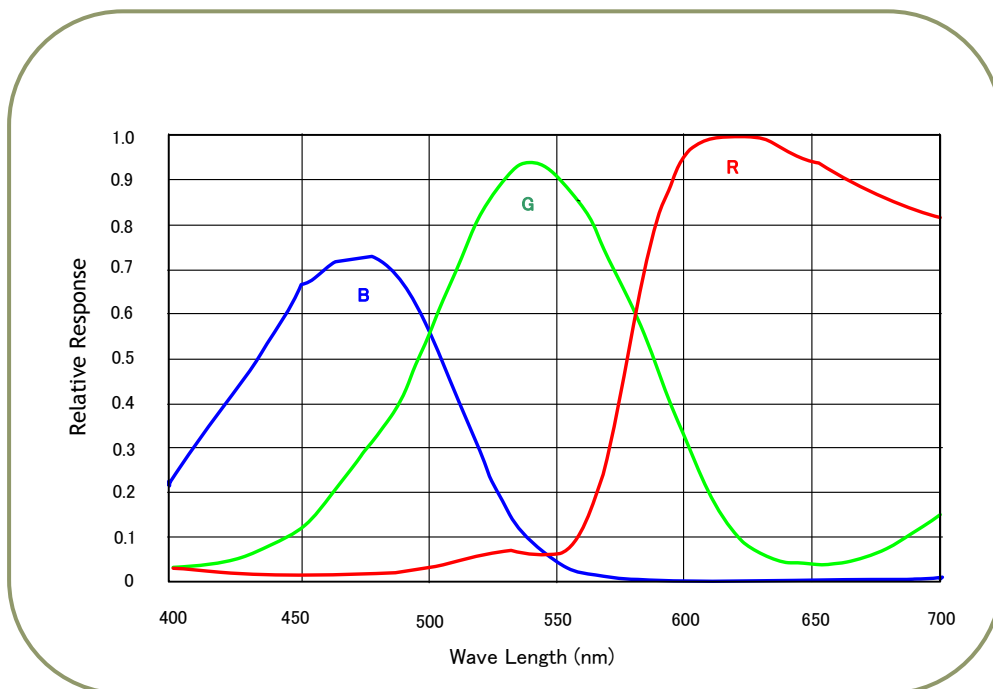

Fig.39 Spectral response for BB-141GE

13.2. Specification table

Specifications	BM-141GE	BB-141GE
Scanning system	Progressive scan	
Frame rate full frame	30.12 frames/sec. Progressive (1052 lines/frame)	
Pixel clock	58 MHz	
Line frequency	31.693 kHz (1H = 31.551 μs) (1830 pixel clock/line)	
CCD sensor	2/3 inch Monochrome ICX285AL	2/3 inch Bayer Color ICX285AQ
Sensing area	8.98 (h) x 6.7 (v) mm 2/3 inch diagonal	
Cell size	6.45 (h) x 6.45 (v) μm	
Active pixels	1392 (h) x 1040 (v)	
Pixels in video output. Full Scan 2/3 partial Scan 1/2 partial Scan 1/4 partial Scan 1/8 partial Scan Variable Partial Scan Vertical Binning Draft Region-of-interest (ROI)	1392 (h) x 1040 (v) 30.12 fps. H = 31.693 kHz 1392(h) x 694 (v) 41.05 fps H= 31.693 kHz 1392 (h) x 520 (v) 50.06 fps. H = 31.693 kHz 1392(h) x 260 (v) 74.57 fps. H = 31.693 kHz 1392 (h) x 130 (v) 98.73 fps. H = 31.693 kHz Start line from 1 to 1025, height(lines) from 8 to 1032 1392 (h) x 520 (v) 50.18 fps. H = 26.447kHz (BM-141GE only) 1392 (h) x 260 (v) 101.17 fps. H = 27.128 kHz (BB-141GE only) User Definable. Memory read-out Note: Partial scan, Vertical Binning and Draft mode cannot be used at the same time	
Sensitivity on sensor (minimum)	0.03 Lux (Max. gain, Shutter OFF, 50% video)	0.2 Lux (Max. gain, Shutter OFF, 50% Green, w/IR cut filter)
S/N ratio	More than 58 dB (0dB gain)	
Digital Video output	GigE Vision Compliant Mono8, Mono10, Mono10_Packed Mono 12, Mono12_Packed	GigE Vision Compliant BAYRG8, BAYGB8, BAYRG10, BAYGB10 BAYRG12, BAYGB12
White Balance	n/a	Manual/One push Continuous Auto (3200K to 9000K) Preset (3200K, 4600K, 5600K)
Iris video output. Analogue	0.7 V p-p , enabled by internal switch	
Gain	Manual / AGC : -6 to +24 dB (1 Step 0.0358 dB)	
Blemish Correction	ON / OFF	
LUT (Look Up table)	OFF: γ=1.0 ON: γ=0.45, LUT (256 points)	
Synchronization	Internal X-tal	
GPIO Module Input/output switch Clock Generator (One) Pulse Generators (Two)	Configurable 16-in / 12-out switch 12-bit counter based on Pixel clock 19-bit counter programmable for length, start point, stop point, repeat	
Hardware Trigger modes	Edge Pre-Select , Pulse Width Control, RCT, Frame Delay and Sequence	
Smearless mode	Available for EPS (Async)	
OB area transfer mode	ON / OFF	
Event message	SYNC / ASYNC mode (Trigger mode status when exposure starts) Exposure start, Exposure end, Trigger IN, Video start, Video end	
Electronic Shutter Preset Shutter speed Programmable exposure Exposure Time (Abs) Exposure Auto continuous GPIO plus Pulse Width	OFF(1/30) and 1/60 to 1/10,000 in 9 steps 2L(63μs) to 1052 L (33.19 ms) in 1L steps μsec - user definable. Same range as PE 64L to 1052L (1/500s to 1/30s) max. 2 sec (Can be set by 100μs unit or Pixel Clock unit)	

BM-141GE / BB-141GE

Specifications	BM-141GE	BB-141GE
Control interface	Register based. GigE Vision / GenIcam compliant	
Functions controlled via GigE Vision Interface	Shutter, Gain, Black Level, Trigger mode, Read out mode, GPIO setup ,ROI (GenIcam mandatory functions)	
GigE Vision Streaming Control	Packet size, Delayed (Frame) read-out, inter-packet delay Jumbo frame can be set at max. 16K(16384) , Default packet size is 1428 Byte.	
Indicators on rear panel	Power, Hardware trigger, GigE Link, GigE activity	
Operating temperature	-5°C to +50°C	
Humidity	20 - 90% non-condensing	
Storage temp/humidity	-25°C to +60°C/20% to 90 % non-condensing	
Vibration	10G (20Hz to 200Hz, XYZ)	
Shock	70G	
Regulatory	CE (EN61000-6-2 and EN61000-6-3), FCC part 15 class B, RoHS, WEEE	
Power	12V DC \pm 10%. 5.1 w	
Lens mount	C-mount Rear protrusion on C-mount lens must be less than 10.0mm	
Optical Low Pass Filter	Built in (Only for BB-141GE)	
Dimensions	55 x 55 x 55 mm (H x W x D)	
Weight	230 g	230 g

Note1: When Gain is set at -4.5db to -6dB, the linearity of the video output may be deteriorated around 100% video output level. Please confirm the output level characteristics when -4.5dB to -6dB gain is set.

In order to get specified performance, it is needed to have approx. 30 minutes pre-heating.

Above specifications are subject to change without notice

Appendix

Precautions

Personnel not trained in dealing with similar electronic devices should not service this camera. The camera contains components sensitive to electrostatic discharge. The handling of these devices should follow the requirements of electrostatic sensitive components.

Do not attempt to disassemble this camera.

Do not expose this camera to rain or moisture.

Do not face this camera towards the sun, extreme bright light or light reflecting objects, including laser sources.

When this camera is not in use, put the supplied lens cap on the lens mount.

Handle this camera with the maximum care.

Operate this camera only from the type of power source indicated on the camera.

Remove power from the camera during any modification work, such as changes of jumper and switch settings.

Typical Sensor Characteristics

The following effects may be observed on the video monitor screen. They do not indicate any fault of the camera, but do associate with typical sensor characteristics.

V. Aliasing

When the camera captures stripes, straight lines or similar sharp patterns, jagged image on the monitor may appear.

Blemishes

All cameras are shipped without visible image sensor blemishes.

Over time some pixel defects can occur. This does not have a practical effect on the operation of the camera. These will show up as white spots (blemishes).

Exposure to cosmic rays can cause blemishes to appear on the image sensor. Please take care to avoid exposure to cosmic rays during transportation and storage. It is recommended using sea shipment instead of air transportation in order to limit the influence of cosmic rays on the camera.

Pixel defects/blemishes may also emerge due to prolonged operation at elevated ambient temperature, due to high gain setting or during long time exposure. It is therefore recommended to operate the camera within its specifications.

Patterned Noise

When the sensor captures a dark object at high temperature or is used for long time integration, fixed pattern noise may appear in the image.

Caution when mounting a lens on the camera

When mounting a lens on the camera dusts particles in the air may settle on the surface of the lens or the image sensor of the camera. It is therefore important to keep the protective caps on the lens and on the camera until the lens is mounted. Point the lens mount of the camera downward to prevent dust particles from landing on the optical surfaces of the camera. This work should be done in a dust free environment. Do not touch any of the optical surfaces of the camera or the lens.

BM-141GE / BB-141GE

Caution when mounting the camera

When you mount the camera on your system, please make sure to use screws of the recommended length described in the following drawing. Longer screws may cause serious damage to the PCB inside the camera.

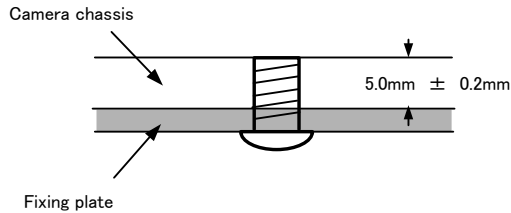

Mounting the camera to fixing plate

If you mount the tripod mounting plate, please use the provided screws.

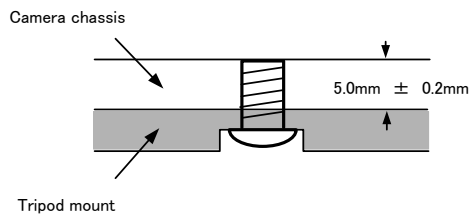

Attaching the tripod mount

Exportation

When exporting this product, please follow the export regulation of your own country.

References

1. This manual for BM-141GE / BB-141GE can be downloaded from www.jai.com
2. Datasheet for BM-141GE / BB-141GE can be downloaded from www.jai.com
3. Camera control software can be downloaded from www.jai.com

BM-141GE / BB-141GE

User's Record

Camera type: BM-141GE / BB-141GE
Revision:
Serial No.
Firmware version.

For camera revision history, please contact your local JAI distributor.

User's Mode Settings.

User's Modifications.

Company and product names mentioned in this manual are trademarks or registered trademarks of their respective owners. JAI A-S cannot be held responsible for any technical or typographical errors and reserves the right to make changes to products and documentation without prior notification.

Europe, Middle East & Africa

Phone +45 4457 8888

Fax +45 4491 3252

Asia Pacific

Phone +81 45 440 0154

Fax +81 45 440 0166

Americas

Phone (toll-free) +1 800 445
5444

Phone +1 408 383 0300

Visit our web site at www.jai.com



See the possibilities