

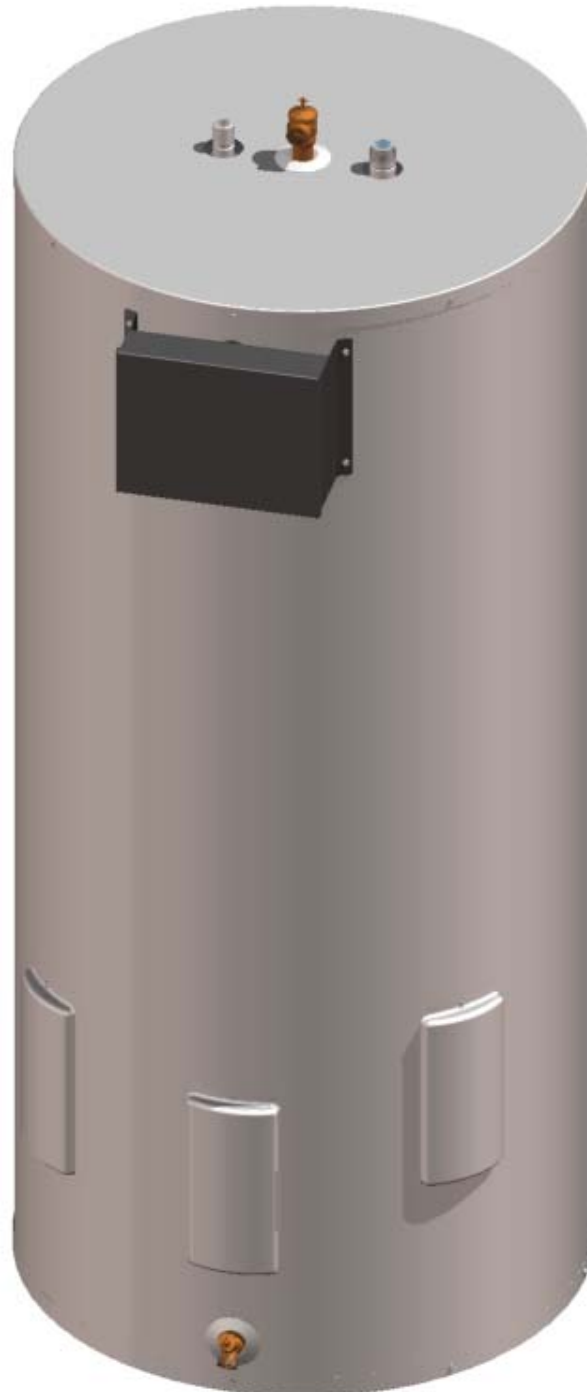

Conversion Kit Instructions

For Models: E32-50S, E32-80R, & E32-120R
(To be performed ONLY by qualified service providers)



Instructions for Conversion of Commercial Electric Models

NOTICE

The conversion procedure outlined in this manual is to be executed **ONLY** by Qualified Service Personnel. Before attempting conversions it is recommended that you read the detailed instructions described herein.

The purpose of this instruction manual is to instruct about the changing of wattage, voltage, and electrical phase for the commercial electric water heaters manufactured by Bradford White Corporation. Underwriters Laboratories Inc. recognizes this procedure as herein presented and no deviation from these instructions are allowed.

Special factory prepared "Conversion Kits" must be used for these conversions. There are separate conversion kits that have individual instructions and **MUST** be followed. Page 4 of these instructions lists the kits that have been prepared for the various wattages and voltages.

These instructions do not allow for a modification that adds or deletes the number of heating elements originally supplied with the heater; therefore such a modification must **NOT** be attempted.

These conversion kits are only applicable to Models E32-50S / E32-80R / E32-120R.

The following information is provided to assist in the successful conversion of the water heater:

	<u>Page</u>
Safety precautions	3
Introduction	3
Required materials and tools	3
Water heater preparation prior to conversion.....	3
Conversion kits.....	4
Conversion of water heater K-W	5
Conversion of water heater operating voltage	6
Conversion of water heater electrical power supply phase.....	7
Recheck and inspection of the conversion results	8
Concluding steps and reassembly after completion.....	9

Instructions for Conversion of Commercial Electric Models

Safety Precautions

NOTICE

The conversion procedure outlined in this manual is to be executed ONLY by Qualified Service Personnel. Before attempting conversions it is recommended that you read the detailed instructions described herein.

Be sure to disconnect the water heater from the electrical supply before performing any servicing of the electrical system or before attempting any of the conversion procedures. Never perform servicing of the electrical system or any of the conversion procedures with wet hands or when you are in contact with water that is on the floor or in the vicinity of the water heater.

Introduction

These conversions have been brought into being in order to expedite the water heater replacement activity. Water heaters suitable for conversion have been wired at the factory to the maximum electrical duty for which they have been designed. Therefore, internal electrical components are provided that satisfy the maximum voltage and maximum electrical current conditions

Wattage, voltage, and phase requirements can be readily fitted to the heater. Conversions may involve altering any one or all of these electrical characteristics.

Required Materials and Tools

- Screw-in element removal wrench --- or --- 1 ½" deep well socket wrench.
- Phillips head screwdriver
- Standard screwdriver
- Conversion Kit that includes: conversion instructions, electrical elements, product label overlay (related to the newly created electrical parameters), and element gaskets. Refer to page 4 of these instructions in order to determine the correct Conversion Kit numbers.

Water Heater Preparation

Locate the areas of the carton to be opened opposite the three electrical elements. A dotted line locates the position on the carton that needs to be scored and cut. Make these three-sided cuts and fold the carton flap outward to make an opening in the carton. The carton flap will be closed to seal the carton after conversion is completed. Remove the three element cover screws and the element covers from the water heater in order to provide access to the elements.

Locate the area of the carton to be opened opposite the electrical enclosure box. A dotted line locates the position on the carton that needs to be scored and cut. Make this three-sided cut and fold the carton flap outward to make an opening in the carton. The carton flap will be closed to seal the carton after conversion is completed.

Instructions for Conversion of Commercial Electric Models

Conversion Kits for Models E32-50S-3/80R-3/120R-3

1. Refer to Table 1 below that contains water heater KW, Element Wattage, Voltage, and kit part numbers.
2. Locate the KW of the required water heater.
3. Move across the table (to the right) until you reach the required voltage.
4. Select the required kit number.
5. Use that kit for this conversion.
6. Refer to the remaining pages for a detailed conversion procedure.

Table 1. Conversion Kit Table

Required Total Water Heater (KW)	Element Wattage	Kit Part Numbers		
		208 volts	240 volts	480 volts
6	2000	265-43942-13	265-43942-07	265-43942-01
9	3000	265-43942-14	265-43942-08	265-43942-02
12	4000	265-43942-15	265-43942-09	265-43942-03
13.5	4500	265-43942-16	265-43942-10	265-43942-04
15	5000	265-43942-17	265-43942-11	265-43942-05
18	6000	265-43942-18*	265-43942-12	265-43942-06

*265-43942-18 will require control box replacement (included in kit).

These three element water heaters with surface mount thermostats have been factory wired with the following common components; terminal block for max service wire size of 2 AWG, 3 elements each having a surface mount thermostat with hi-limit control, two fuse blocks rated at 480 volts ac max, and 6 type G 30 amp fuses (rated at 480 volts max).

Instructions for Conversion of Commercial Electric Models

Wattage/Voltage Conversion --- Element Changes

1. Remove and replace one element at a time.
2. Disconnect the electrical wires from the element terminals.
3. Remove the electrical elements using the Screw-in element removal wrench --- or ---- a 1 ½” deep well socket wrench.
4. Remove the replacement elements from the conversion kit. Check the element markings to ensure correct wattage and voltage before installing.
5. Apply the new gasket (provided in the kit) to the element. Make sure the gasket is aligned correctly and it is not rolled-over.
6. Thread the replacement element into the element fitting until it is seated. Tighten ½ to ¾ turns with the element wrench.
7. Re-connect the wiring to the element terminals. The screw should be snugly tightened but caution should be exercised not to over tighten. Over tightening could fracture the element ceramic terminal block, and would require replacement.
8. Repeat this procedure (steps 1 thru 7 above) for all other elements needing replacement.

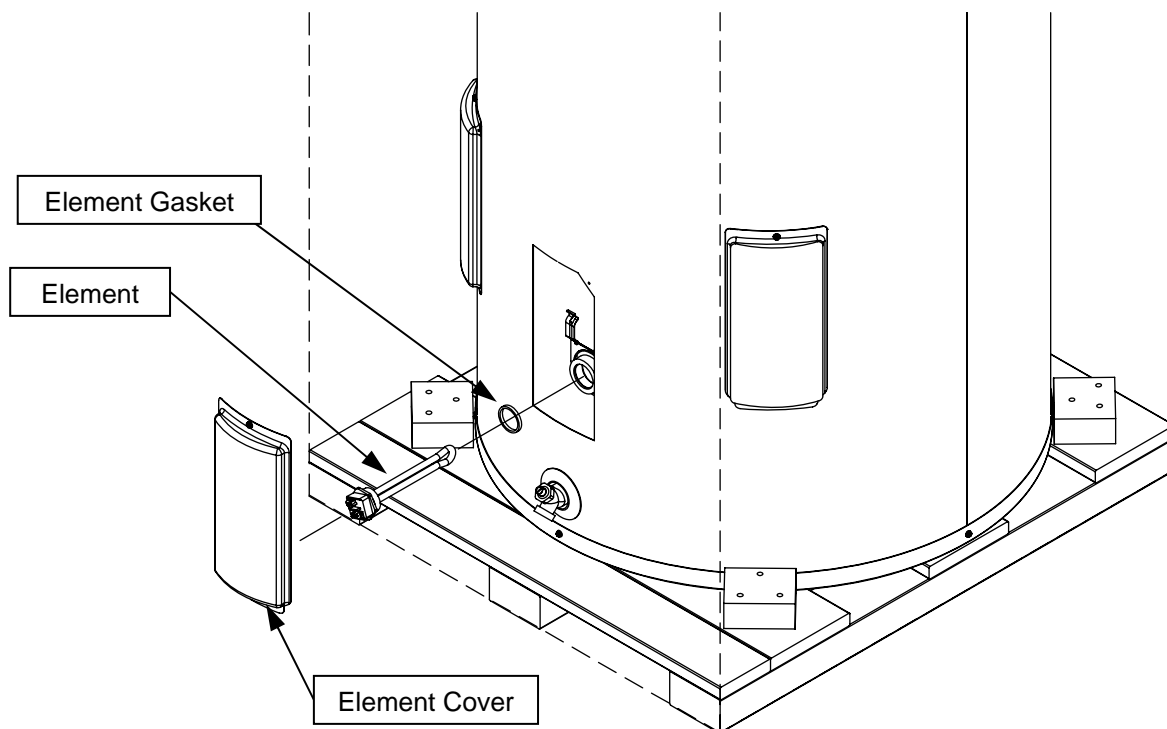

Figure 1. Example of element removal/installation.

Instructions for Conversion of Commercial Electric Models

Voltage Conversion

1. Voltage conversion is accomplished by replacing the existing elements with elements that are rated at the required voltage.
2. To accomplish this conversion refer to the above procedure for KW Conversion ---- Element Changes.
3. Execute steps 1 thru 8 of that procedure.

Control Box Conversion

NOTICE

Control box conversion is **ONLY** required when converting water heater to 18Kw 208v (Kit # 265-43942-18).

1. Open front panel of control box installed on water heater and disconnect the (6) load wires from fuse blocks.
2. Remove (4) screws joining control box to water heater and remove control box.

CAUTION

Use caution to not damage any of the wire insulation when removing control box.

3. Install new control box onto the water heater by feeding the wires through the back of the control box and reinstall (4) mounting screws.
4. Reconnect wires to new fuse blocks. Be certain to match wire colors to Line side of fuse blocks.

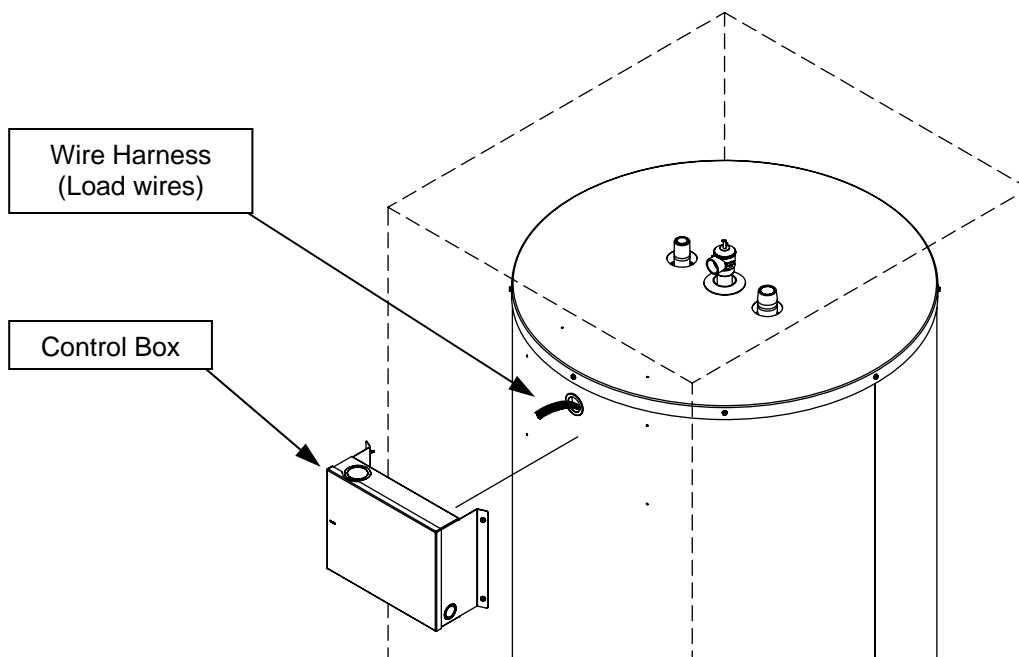

Figure 2. Example of control box removal/installation.

Instructions for Conversion of Commercial Electric Models

Electrical Phase Conversion

Electrical phase conversion will require a change from single-phase to three-phase or an opposite conversion change from three-phase to single-phase. Each of these conversions will be explained separately as follows:

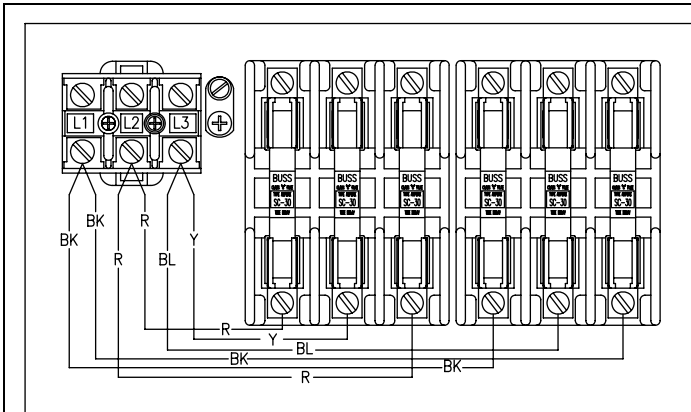

Figure 3.

Example of finished Three Phase construction.

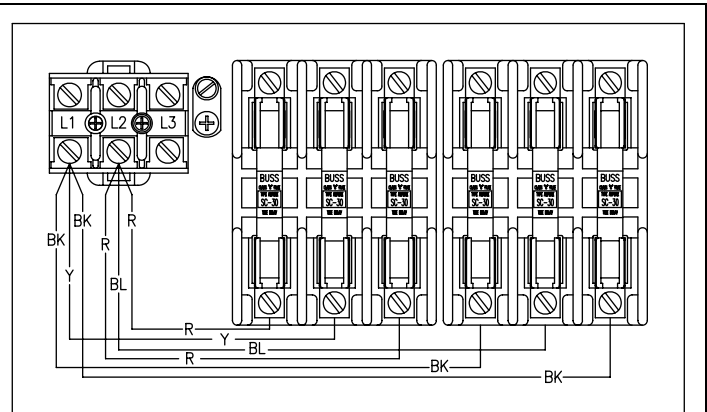

Figure 4.

Example of finished Single Phase construction.

Instructions to convert FROM Three-Phase TO Single-Phase:

(All connections are to be made on the LOAD side of the terminal block)

1. Disconnect blue wire and yellow wire from terminal L-3 of the terminal block.
2. Connect yellow wire to terminal L-1 of the terminal block. The black wires should remain connected to L-1 of the terminal block as it was originally manufactured.
3. Connect blue wire to terminal L-2 of the terminal block. The red wires should remain connected to L-2 of the terminal block as it was originally manufactured.
4. Field wiring for the water heater power supply will eventually be connected to the line terminals L-1 and L-2 of the terminal block when the product is installed.

Instructions to convert FROM Single-Phase TO Three-Phase:

(All connections are to be made on the LOAD side of the terminal block)

1. Disconnect yellow wire from terminal L-1 of the terminal block
2. Disconnect blue wire from terminal L-2 of the terminal block
3. Connect both blue and yellow wires to L-3 of the terminal block
4. Field wiring for the water heater power supply will eventually be connected to the line terminals L-1, L-2, and L-3 of the terminal block when the product is installed.

Instructions for Conversion of Commercial Electric Models

Phase Conversion Only kits

Table 2. Phase Conversion Kits.

6KW		9KW		12KW	
Volts	Conversion Kit	Volts	Conversion Kit	Volts	Conversion Kit
208	265-45246-13	208	265-45246-14	208	265-45246-15
240	265-45246-07	240	265-45246-08	240	265-45246-09
480	265-45246-01	480	265-45246-02	480	265-45246-03
13.5KW		15KW		18KW	
Volts	Conversion Kit	Volts	Conversion Kit	Volts	Conversion Kit
208	265-45246-16	208	265-45246-17	208	265-45246-18
240	265-45246-10	240	265-45246-11	240	265-45246-12
480	265-45246-04	480	265-45246-05	480	265-45246-06

WARNING

Recheck and inspect to make certain all components involved in the conversion are correct and secure.

Recheck all of the electrical wiring changes made against the wiring diagram requirements for accuracy. Check to insure all of the electrical connections are tightly secured and the electrical wire routings are orderly.

Special attention should be given to the electrical heating elements. The wattage and voltage rating of the element is marked on the element itself. Confirm the marking agrees with the intended conversion. Additionally, the element wattage can be verified by checking the electrical resistance (ohms of resistance) with an Ohm Meter. This should be done initially before connecting the element to the circuit. The element resistance should be plus or minus 5 percent of the following values:

Table 3. Ohms of Electrical Resistance.

Element Wattage	Voltage Rating of the Element		
	208 volts	240 volts	480 volts
2000	21.6	28.8	115.2
3000	14.4	19.2	76.8
4000	10.8	14.4	57.6
4500	9.6	12.8	51.2
5000	8.7	11.5	46.1
6000	7.2	9.6	38.4

Instructions for Conversion of Commercial Electric Models

Concluding Steps

The water heater rating plate will need to be modified because the conversion altered the electrical characteristics of the water heater. Refer to Figure 5 which displays a typical commercial electric rating plate that is to be altered. This rating plate is placed on every Commercial Electric water heater produced by Bradford White Corporation. Locate this rating plate on the water heater you have just converted.

BRADFORD WHITE CORPORATION (www.bradfordwhite.com) 200 LAFAYETTE ST. MIDDLEVILLE MI 49333 Model No: E32-50S3 Serial No: ZB2564812 D/N: Cap. 50(gal.)/ 189.3(Liters) Press: Test 300(psi), Working 150(psi)		
Volts 240	Max Temp 180	
Phase 3	Amps 43.3	3 Elements
KW Each 06.0	Total KW 18.0	
Wattage rating based upon 60 HZ		

Figure 5. Rating plate example.

Also locate the adhesive backed label (see Figure 6) that is provided inside the kit. The label will be marked with the new electrical data that is accurate for the conversion just executed. The kit will contain two labels for this voltage and KW, (1) for three phase and (1) for single phase. Select the correct label for the electrical phase in this conversion.

Volts 480			Max Temp 180	
Phase 3			Amps 7.2	3 Elements
KW Each 02.0			Total KW 06.0	
Wattage rating based upon 60 HZ				238-43990-XX

Figure 6. Rating plate overlay example.

Remove the adhesive peel strip and place this label onto the rating plate in such a manner that the new electrical data will appear in place of the data originally marked. Refer to Figure 7 to the right that displays the rating plate revision.

BRADFORD WHITE CORPORATION 200 LAFAYETTE ST. MIDDLEVILLE MI 49333 Model No:E32-50S3 Serial No:ZB2564812 Dash No: Cap. 50(gal.)/ 189.3(Liters) Press: Test 300(psi), Working 150(psi)		
Volts 480	Max Temp 180	
Phase 3	Amps 7.2	3 Elements
KW Each 02.0	Total KW 06.0	
Wattage rating based upon 60 HZ		
238-43990-XX		

Figure 7. Rating plate with overlay installed.

Replace all insulation pieces and element covers that were removed. Replace the electrical enclosure door. Heater identification information that was placed on the water heater carton must also be altered. This can be done by making a bold face inscription on the carton with a large size black ink marker. Write the new electrical data in place of the original data.

NOTES

NOTES



Ambler, PA

For U.S. and Canada field service,
Contact your professional installer or
local Bradford White representative.

Sales/**800-523-2931**
Fax/215-641-1670
Parts Fax/215-641-2180

Technical Support/**800-334-3393**
Fax/269-795-1089

Warranty/**800-531-2111**
Fax/269-795-1089

International:
Telephone/**215-641-9400**
Telefax/215-641-9750



Mississauga, ON

Sales/**866-690-0961**
905-238-0100

Fax/905-238-0105
Technical Support/**800-334-3393**

Email
parts@bradfordwhite.com
techserv@bradfordwhite.com

www.bradfordwhite.com