

# K-SYSTEMS Instruction Manual

## CO<sub>2</sub> Bench Top Incubator G85



## Table of contents

<b>1</b>	<b>GENERAL INFORMATION &amp; SERVICE</b> .....	<b>3</b>
<b>2</b>	<b>UNPACKING AND INSPECTION</b> .....	<b>4</b>
<b>3</b>	<b>ACCESSORIES</b> .....	<b>4</b>
3.1	STANDARD ACCESSORIES .....	4
3.2	OPTIONAL EQUIPMENT .....	5
<b>4</b>	<b>USER MANUAL</b> .....	<b>6</b>
4.1	DEFINITION OF USE.....	6
4.2	GENERAL DESCRIPTION .....	6
<b>5</b>	<b>FEATURES AND OPERATION</b> .....	<b>7</b>
5.1	ASSEMBLING THE G85 .....	7
5.2	CONNECTION TO THE MAINS.....	7
5.2.1	<i>Start of apparatus</i> .....	7
5.3	KEYBOARD FUNCTIONS .....	8
5.4	OPERATING THE HEATED COMPARTMENT.....	9
5.5	TEMPERATURE SETTING AND CONTROL.....	9
5.6	COMBINATION KEYS.....	9
5.7	GAS FLOW SETTING .....	10
5.7.1	<i>Why gassing?</i> .....	10
5.7.2	<i>Working gas pressure</i> .....	10
5.7.3	<i>Humidifying the gas mixture</i> .....	11
5.7.4	<i>Purge function</i> .....	13
5.8	TEMPERATURE/FLOW ALARM.....	14
5.8.1	<i>Temperature alarm</i> .....	14
5.8.2	<i>Gas flow alarm</i> .....	14
5.9	WARMING UP .....	15
<b>6</b>	<b>MENU FUNCTION</b> .....	<b>16</b>
6.1	OVERVIEW OF OPTIONS .....	17
6.2	UNIT .....	18
6.3	RS232 .....	19
6.4	TUNE .....	20
6.5	INT.T.....	21
6.6	TL.St.....	21
6.7	St.St.....	22
6.8	HEAT .....	23
6.9	A-ST.....	24
6.10	HOUR.....	25
6.11	REST.....	26
<b>7</b>	<b>USER MAINTENANCE</b> .....	<b>27</b>
7.1	CLEANING .....	27
7.2	CALIBRATION.....	27
<b>8</b>	<b>TROUBLE SHOOTING</b> .....	<b>28</b>
<b>9</b>	<b>TECHNICAL DATA</b> .....	<b>29</b>
<b>10</b>	<b>LIMITED WARRANTY</b> .....	<b>30</b>
<b>11</b>	<b>LIABILITY</b> .....	<b>31</b>
<b>12</b>	<b>REPLACEMENT</b> .....	<b>31</b>

## 1 General Information & Service

### COPYRIGHT

This manual contains information that is subject to copyright. All rights reserved. This manual should not be photocopied, otherwise copied or distributed, completely or in part, without the approval of K-SYSTEMS Kivex Biotec.

Users of K-SYSTEMS Kivex Biotec products should not hesitate to contact us if there are any unclear points or ambiguities in this manual.

K-SYSTEMS  
Kivex Biotec A/S  
Klintehøj vænge 3-5  
3460 Birkerød  
Denmark

Tel.: +45 45 99 56 00

Fax: + 45 45 99 56 19

E-mail: [info@K-SYSTEMS.dk](mailto:info@K-SYSTEMS.dk)

Internet: [www.K-SYSTEMS.dk](http://www.K-SYSTEMS.dk)

Issue 2

**Changenote No: 422**

### **Service address:**

Please contact your local K-SYSTEMS Kivex Biotec distributor for details of your nearest authorized service agent.



***CAUTION** If the equipment is used in a manner not specified by this manual, the safety of the user may be at risk and the equipment may be damaged. Always use the equipment as outlined in this instruction manual.*

## 2 Unpacking and inspection

- **Unpack the equipment.**
- **Check the packing list to insure all accessories are there.**
- **Examine the packing material carefully for separately packed items.**
- **Check the incubator for external surface damage.**
- **Check that the display is not broken or damaged.**
- **• Check that the lids and gas flow regulator knob operate correctly without any hindrance.**

## 3 Accessories

### 3.1 Standard accessories

<p>24 volts main adapter (PSU)</p> <p>Order code: 51122</p>	
<p>Mains Cable</p> <p>Standard Schuko – Oder code: 52768                  UK – Order code: 53886                  US – Order code: 52773</p>	
<p>Silicone tube</p> <p>Order code: 11066</p>	

### 3.2 Optional equipment

Optional equipment consists of a range of warming blocks. Please contact your local distributor or K-SYSTEMS Kivex Biotec for details about the full range of warming blocks.

<p>Warming block B16 Holds two culture dishes</p> <p>B16F – Falcon 353001 Order code:26059</p> <p>B16N – NUNC 150318 Order code: 26060</p>	
<p>Warming block B24 Holds one center well dish</p> <p>Falcon 353653</p> <p>Order code: 26027</p>	
<p>Warming block B25 Holds one 60 mm culture dish</p> <p>Falcon 353002 NUNC 150288</p> <p>Order code: 26028</p>	
<p>Warming block B26 Holds one 4-well Falcon dish with lid</p> <p>Falcon 353654</p> <p>Order code: 26031</p>	
<p>Warming block B28 Holds one 4-well dish</p> <p>NUNC 176740</p> <p>Order code: 26029</p>	
<p>Warming block B29 Holds one 5-well dish</p> <p>MiniTüb 19021/0005</p> <p>Order code: 26030</p>	

## 4 User Manual

### 4.1 Definition of use

The K-SYSTEMS Kivex Biotec G85 CO<sub>2</sub> Bench Top incubator is designed for keeping gametes and embryos in a controlled environment.

### 4.2 General description

The chambers and aluminum warming blocks maintain a preset temperature in the range ambient to 42° C. The temperature is electronically controlled by a PID controller and can be read on the displaying increments of 0.1° C.

The G85 features heated lids. The bottom part is made from thick aluminum that gives ideal temperature distribution. Back part that houses the electronic is made from stainless steel. Interchangeable aluminum Warming blocks holding a variety of culture dishes are available.

The G85 features a built in digital flow meter with a possible flow of 0 - 29 liters per hour and a humidification system.

The G85 has also a purge function enabling a quick CO<sub>2</sub> level recovery within the chambers. The recovery time is 15 seconds with a pressure of 0.5 bar.

*Note*      *The atmosphere in the chambers may be controlled by flushing with a gas mixture. Use only 5% CO<sub>2</sub> in air.*

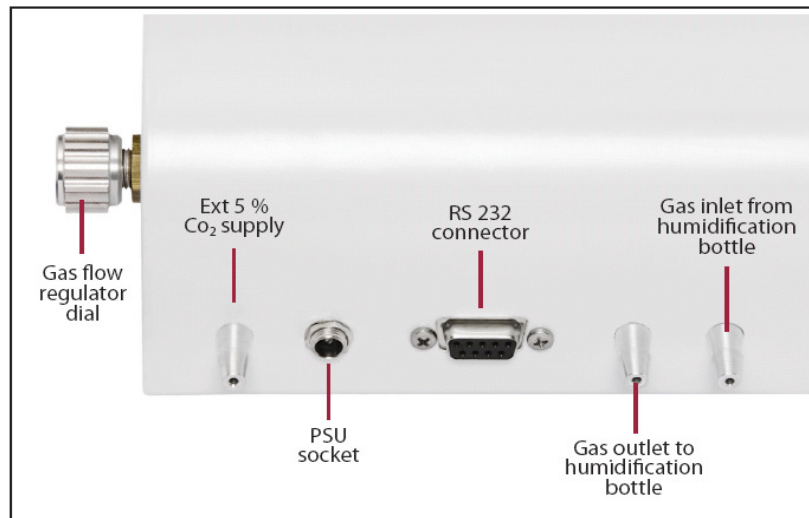

## 5 Features and operation

### 5.1 Assembling the G85

No assembly needed. Just follow directions in section 5.2 and the unit is ready for use.

### 5.2 Connection to the mains

The mains voltage is automatically regulated to the correct level by the main adapter (PSU).

Connect the G85 to the mains supply using the enclosed PSU.

For safety reasons the unit has an external PSU which operates at a low voltage.

#### 5.2.1 Start of apparatus

Connect the unit to the PSU and the PSU to the mains wall socket.

To power up the unit, press the heat on button on the keyboard. The display will indicate the current temperature.

The aluminum dial on the side of the G85 can be turned and the gas flow level is adjusted. The valve controlling the flow is a precision valve with a short span from closed to open, so adjust with slow movements. A hint for adjusting is to close it fully and then open it gently.



### 5.3 Keyboard functions



Purge	
Heat ON/Off	
LED Display	
Setpoint	
Arrow keys UP/DOWN	
Alarm	



### 5.4 Operating the heated compartment







Action	Key	Display
Press heat ON/OFF key to show the actual temperature.		

### 5.5 Temperature setting and control

Action	Key
Press setpoint key and the set temperature is shown.	
Press and hold setpoint key.	
While holding the setpoint key in, press either the arrow UP or arrow DOWN key to raise or lower the set temperature.  When the desired temperature is reached, let go of the setpoint key.	

*Note* The setpoint can be adjusted to a reading between ambient and 49.9 °C.

### 5.6 Combination keys

Action	Key	Display
Press alarm and UP key.	 + 	The keyboard is locked.
Press alarm and UP key.	 + 	The keyboard is unlocked.
Press Heat ON/OFF and setpoint key.	 + 	Switches between temperature and time.

## 5.7 Gas flow setting

The display can switch between temperature and flow rate.

The flow rate is shown in the display by the integrated digital flow meter in the G85.

Action	Key
Press arrow key either up or down one time.  Now the flow rate in liter per hour will be shown.	

The flow rate can be adjusted between 0 – 29 l/h.

If the flow becomes larger than 29 l/h the display will indicate “Hi” (see section 5.8).

Action	Key
Press arrow key either up or down once again to change to the display of temperature.	

### 5.7.1 Why gassing?

Most of the culture media which are used in assisted reproduction techniques are sensitive to changes in pH. Culture media must be maintained at a pH about 7.4. This can be obtained by gassing with atmosphere of 5% or 6% CO<sub>2</sub>.

### 5.7.2 Working gas pressure

Working gas pressure (inlet pressure on the G85) must be regulated to 0.5 bar by a reduction valve. The reduction valve must be a high quality unit of the pressure type that can be adjusted precisely in the 0-1 bar range.

The flow rate on the G85 must be adjusted to a specific level in accordance with the use of the unit.

Frequent openings of the lids will require higher flow rates.

*Note Any use of flow type regulators or inadequate quality pressure type regulators will cause the flow on the G85 to be unstable and drift.*

Below is listed the full recovery rates for CO<sub>2</sub> level in both chambers in minutes.

This can be used as guideline for the use.

Flow (l/h)	*	10	28	50
Time (min)	**	12	2.8	0.9

\*Flow setting in display of G85.

\*\*Time it will take to recover CO<sub>2</sub> level after a chamber has been opened at the above flow setting.

If the use necessitates low recovery times, either a constant high flow must be used or purging the chambers by setting the flow level at a high rate for 2-3 minutes.

A flow of 10 l/h will be sufficient to sustain the CO<sub>2</sub> levels in the chambers when the lids are not opened. The flow rate should at no time be kept under 8 l/h.

A flow rate of 15-20 l/h should be adequate under most conditions without the use of manual purge.

### 5.7.3 Humidifying the gas mixture

In order to avoid Gassing with cold and dry Gas, the built in humidifier can be used.

Connect the tubes as show on the picture below.

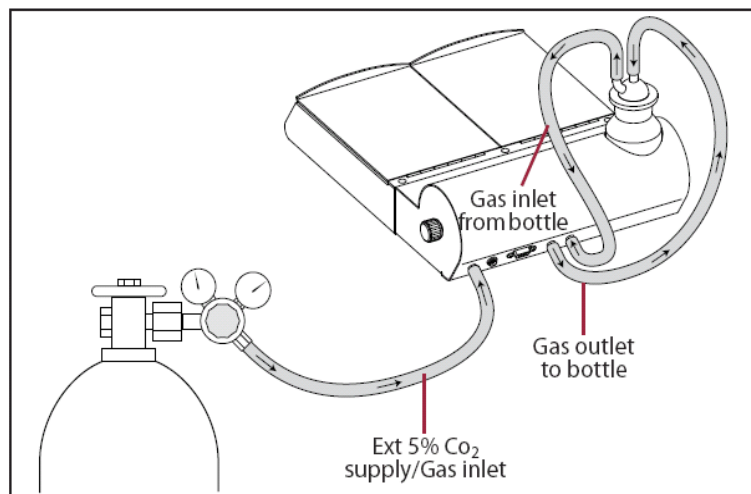

**Warning** Always route the gas as shown or permanent damage to the airflow sensors may occur.

If the humidification system is not used and the gassing is done with dry gas, a silicone tube U loop must be connected between the outlet and inlet for the humidification bottle.

K-SYSTEMS have experienced a quantity of failures on the flow sensors due to liquid entering the sensor and damaging it.

The fault is registered by the user getting a "0" reading in the display, when an obvious flow can be seen as bubbles in the humidification flask.

When adjustment in the flow rate is done on the regulator valve on the side of the G85, no changes can be seen to the flow reading in the display. It will stay at "0" disregarding the flow.

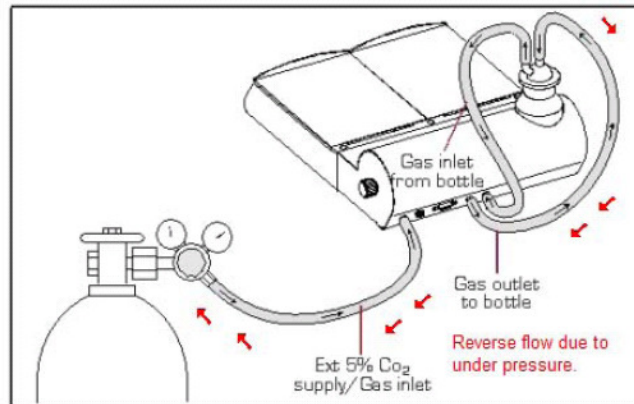

The fault occurs because of under pressure in the gas supply when the G85 is not in use.

If the user shuts off the gas supply only on the bottle or the external regulator an under pressure will develop. The under pressure will draw back liquid from the humidification bottle through the gas outlet to bottle tube and into the G85 where it will damage the flow sensor.

If the user remembers to completely close the regulator valve on the side of the G85 no such problem will occur.

- Alternatively the exterior 5% CO<sub>2</sub> supply tube should be disconnected from the G85 when the G85 is not in use.

Or:

- The Gas outlet to bottle tube disconnected when the G85 is not in use.

There is no recommended hardware update at this time, as such an under pressure cannot be avoided with certain types of gas regulators. We have considered the addition of a one-way flow valve in the circuit, but test have shown that under unfortunate circumstances the process can still be triggered.

The only fully safe way to avoid the problem is as described above.

A notice or warning sticker could be added to the G85:

- Close regulator valve fully when not in use:

Or:

- The Gas outlet to bottle tube disconnected when the G85 is not in use

There is no recommended hardware update at this time, as such an under pressure cannot be avoided with certain types of gas regulators. We have considered the addition of a one-way flow valve in the circuit, but test have shown that under unfortunate circumstances the process can still be triggered.

The only fully safe way to avoid the problem is as described above.

A notice or warning sticker could be added to the G85:

- Close regulator valve fully when not in use:

Or:

- Disconnect gas outlet to bottle tube when not in use.

If the problem has occurred the gas flow sensor PCB will need to be replaced.

#### 5.7.4 Purge function

The G85 has a purge function enabling to have a fast recovery of the CO<sub>2</sub> level within the chambers. This function is to be used when the lid of the chambers have been opened in order to place or remove culture dishes. The purge time is 15 seconds.

Action	Key
<p>Press the alarm key to activate the purge function.</p> <p>When activated a “Pu” indication appears on the display.</p>	

## 5.8 Temperature/Flow alarm

The G85 has one alarm which is activated on two events:





- Temperature deviations (high or low)
- Gas flow

### 5.8.1 Temperature alarm

The temperature alarm indicates too high or too low temperature.

The alarm will be activated if the temperature rises or falls more than 0.5° C from the setpoint.

There will be an acoustic signal and the red LED light in the alarm key will be activated.

Action	Key
Press setpoint key and alarm key to mute the acoustic signal.	 + 
Press setpoint key and alarm key once again to bring the signal back on.	 + 

*Note* The red LED and the acoustic signal will turn off if the temperature or gas flow stabilizes again to the setpoint level.

### 5.8.2 Gas flow alarm

The gas flow alarm will get activated, if the flow is higher than 29 l/h.

The display will then show “**hi**”.

The alarm will also be activated if the flow is “on”, and the heat “off”.

In this case the display will show “**f.on**”.

*Note* The maximum flow is 29 l/h. The G85 will not be damaged by a higher flow as long as the gas flow is kept below 100 l/h.

## 5.9 Warming up

Warming up from 20.0 to setpoint takes less than 30 minutes, under normal conditions. When a cold item is placed in either of the chambers it may need up to 40 minutes to stabilize, depending on the thermal mass of the object and the initial temperature.





G85 with two warming blocks in one chamber and humidifier show on the picture below.



*Note* Always place a warming block in the chambers during warm up and be careful with the heated area under the humidifier bottle as it will become hot.

## 6 Menu function

The user can access a number of advanced functions via the menu.

Action	Key	Display
<p>Press and hold UP+DOWN key for 3 seconds to enter the menu.</p> <p>The first option "UNIT" will appear in the display.</p>		
<p>Press UP/DOWN key to navigate within the Menu.</p>		
<p>While holding the setpoint key in, press either the arrow UP or arrow DOWN key to change values within the options.</p>		
<p>Press and hold UP+DOWN key for 3 seconds again to exit the menu.</p>		



The menu consists of the 10 options listed below.  
 For further detail see the description on the following pages.



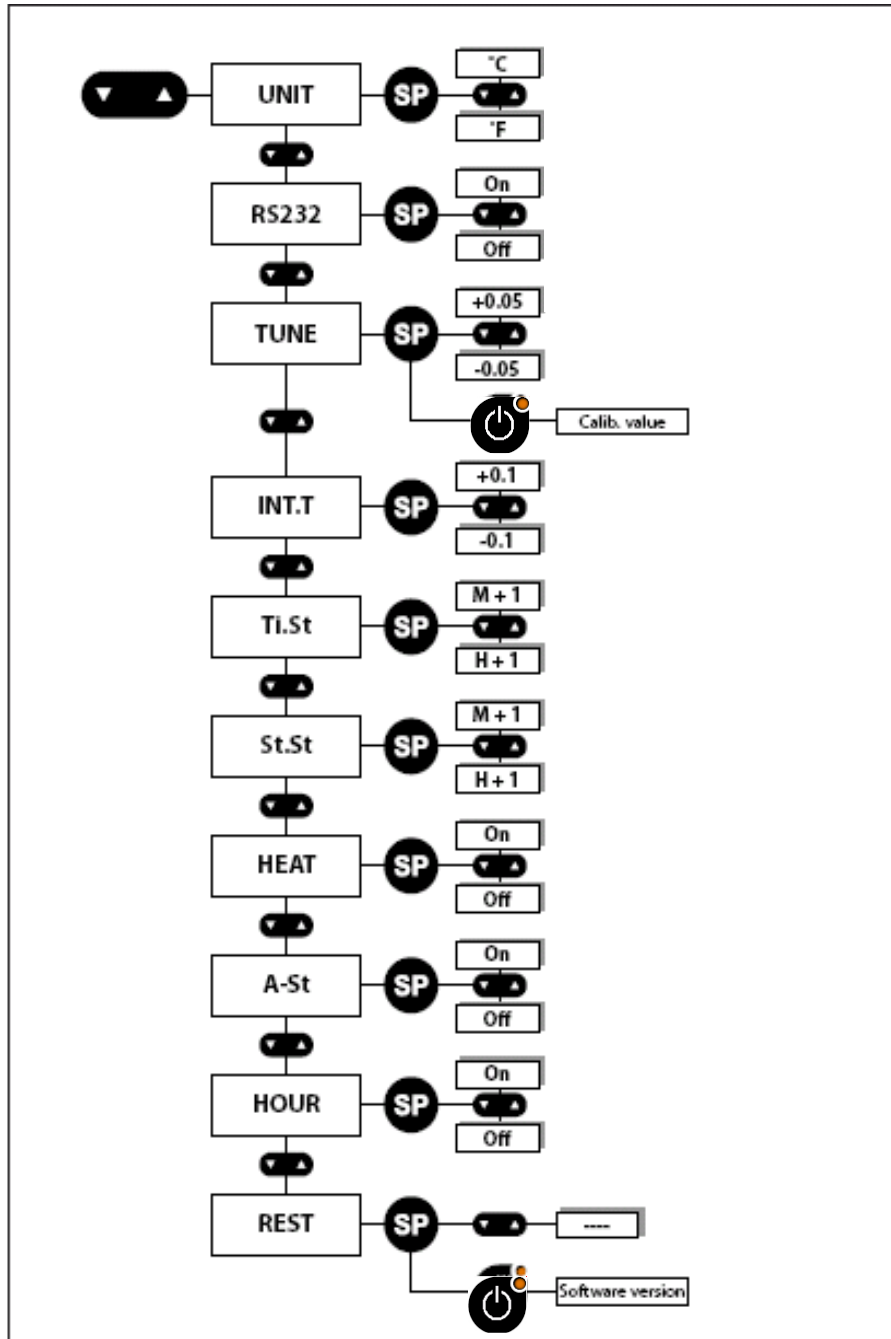

### 6.1 Overview of options



## 6.2 UNIT

In the UNIT option the **displayed temperature** unit can be set to either degrees **Celsius** or **Fahrenheit**.







Follow these steps to navigate in the UNIT option.

Action	Key	Display
<p>Press and hold UP+DOWN key for 3 seconds to enter the menu.</p> <p>The menu "UNIT" will appear in the display.</p>		
<p>Press and hold setpoint key to change values.</p>		
<p>While holding the setpoint key in, press either the arrow UP or arrow DOWN key to select the required type of unit.</p> <p>When the required type has been selected let go of the setpoint key.</p>		
<p>Press and hold UP+DOWN key for 3 seconds to exit the menu.</p>		

### 6.3 RS232

The RS232 option is for serial communication and data logging of the **temperature and alarm conditions**.

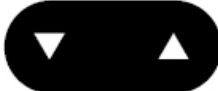
Follow these steps to navigate in the RS232 option.

Action	Key	Display
<p>Press and hold UP+DOWN key for 3 seconds to enter the menu.</p> <p>The option "UNIT" will appear in the display.</p>		
<p>Press DOWN key until the option "RS232" appears in the display.</p>		
<p>Press and hold setpoint key to change values.</p>		
<p>While holding the setpoint key in, press either the arrow UP or arrow DOWN key to select between "ON" and "OFF".</p> <p>"OFF": The RS232 function is turned off.</p> <p>"ON": Data is send once every two seconds.</p> <p>When the required setting is activated, let go of the setpoint key.</p>		
<p>Press and hold UP+DOWN key for 3 seconds to exit the menu.</p>		

Data logging the temperature valves during use

*Note*      *The use of this function warrants extra equipment software.  
The parameters on or off will not affect  
normal usage when serial communication is not connected.*







## 6.4 TUNE

The TUNE option is for **calibration** of the **displayed temperature**.

If there is an offset between the value on the display and any measurements made with a high precision external temperature sensor, this can be corrected.

The new temperature reading will be kept as the displayed value, with temperature control conducted on this basis.

Follow these steps to navigate in the TUNE option.

Action	Key	Display
Press and hold UP+DOWN key for 3 seconds to enter the menu. The menu "USER" will appear in the display.		
Press DOWN key until the option "TUNE" appears in the display.		
Press and hold setpoint key to change values.		
While holding the setpoint key in, press either the arrow UP or arrow DOWN key to select the value temperature. When the required setting is activated, let go of the setpoint key.		
Press and hold UP+DOWN key for 3 seconds to exit the menu.		



*Any change in the factory set calibration should always be based on very certain temperature measurements. K-SYSTEMS Kivex Biotech only recommend the use of a high quality PT-100 sensor that is calibrated with the precision instrument used for measuring according to the manufacturers specifications. Also ensure an optimal contact between the sensor and the place measured. Use only a sensor type that is correct for the purpose and of correct size. If in doubt contact your local distributor or K-SYSTEMS Kivex Biotech.*

### 6.5 INT.T







The INT.T (Integral Time) option is for changing the **base value** for the **PID controller**. This should not be attempted by unauthorized persons. If set at a different level the controlling principle will be affected. From the factory it is set to a closely calculated value specific for the model.

*CAUTION Do not change the value here. If by mistake any changes are made or doubts occur if the value are correct please set the REST function in the menu for the restore of the defaults.*

### 6.6 Ti.St

The Ti.St (Time Set) option is for **setting the time**.

Follow these steps to navigate in the Ti.St option.

Action	Key	Display
Press and hold UP+DOWN key for 3 seconds to enter the menu. The option "UNIT" will appear in the display.		
Press DOWN key until the option "Ti.St." appears in the display.		
Press and hold setpoint key to change values.		
While holding the setpoint key in, press either the arrow UP to change minutes or arrow DOWN key to change the hour.		
Press and hold UP+DOWN key for 3 seconds to exit the menu.		







## 6.7 St.St

The St.St (Start Set) option is the **timer function** for the **heat**.

By using this option, time can be saved as the G85 can be ready for use before procedures start in the morning.

*Note* This function will only work correctly if the clock is set.

Follow these steps to navigate in the St.St option.

Action	Key	Display
Press and hold UP+DOWN key for 3 seconds to enter the menu. The menu "UNIT" will appear in the display.		
Press key DOWN until the option "St.St" appears in the display.		
Press and hold setpoint key to change values.		
While holding the setpoint key, press either the arrow UP to change minutes or arrow DOWN key to change the hour. When the time is set, let go of the setpoint		
Press and hold UP+DOWN key for 3 seconds to exit the menu.		

*Note* If the function Heat is set, a dot will light up in the right side of display.

St.St is connected with HEAT. It must be chosen when the timer starts. To turn the heater on, please see section 6.8.







**WARNING** Always make sure when the timer function is being used, that the heated area is clear of any objects that might be damaged by the heat or adversely affected by it in way. Caution should always be exercised when a heated area is turned on without any supervision.

## 6.8 HEAT

The HEAT option is used for the heater to **turn on at a certain time**.

*Note*        *This function only works in conjunction with St.St.  
If St.St is set to 8.00 and heat function is on, the heater will  
automatically turn on at 8.00 using 24 hour clock.*

Follow these steps to navigate in the HEAT menu.

Action	Key	Display
Press and hold UP+DOWN key for 3 seconds to enter the menu. The first menu "UNIT" will appear in the display.		
Press DOWN key once and the menu "HEAT" appears in the display.		
Press and hold setpoint key to change values.		
While holding the setpoint key in, press either arrow UP or arrow DOWN key to select between "ON" and "OFF".  When the required setting is activated, let go of the setpoint key.		
Press and hold UP+DOWN key for 3 seconds to exit the menu.		







*Note*        *A dot will turn on in the right side of display, indicating that the Heat function is active.*

## 6.9 A-ST

The A-St (Automatic Start) option is used to **repeat the timer** (St.St) function **every day of the week**.

*Note* This function works in conjunction with St.St and HEAT.  
 If St.St is set to 8.00 and heat function is on, the heater will automatically turn on at 8.00 every day.

Follow these steps to navigate in the A-st option.

Action	Key	Display
Press and hold UP+DOWN key for 3 seconds to enter the menu.  The option "UNIT" will appear in the display.		
Press DOWN key until the option "A-st" appears in the display.		
Press and hold setpoint key to change values.		
While holding the setpoint key in, press either arrow UP or arrow DOWN key to select between "ON" and "OFF".  When the required setting is activated, let go of the setpoint key.		
Press and hold UP+DOWN key for 3 seconds to exit the menu.		







*Note* If this function is set to 'on' the heat function will be repeated every day, but if A-St function is set to "off" the heat function will only be activated one time.





## 6.10 HOUR

The HOUR option gives the opportunity to **show the time** on the display when the **heat is off**.



Follow these steps to navigate in the HOUR option.

Action	Key	Display
Press and hold UP+DOWN key for 3 seconds to enter the menu.  The option "UNIT will appear in the display.		
Press DOWN key until the option "HOUR" appears in the display.		
Press and hold setpoint key to change values.		
While holding the setpoint key in, press the arrow UP or arrow DOWN key to select between "ON" and "OFF".  When the required setting is activated, let go of the setpoint key.		
Press and hold UP+DOWN key for 3 seconds to exit the menu.		

If you want to see the time on the display when the heat is turned on. Follow these steps to switch between time and temperature.

Action	Key	Display
Press and hold setpoint key.		
While holding the setpoint key in, press the HEAT key one time, then let go of the setpoint key.  The display now shows the time.		

To change back to temperature.

Action	Key	Display
Press and hold setpoint key.		
Press the HEAT key one time, then let go of the setpoint key.  The display now shows the temperature.		

*Note* The time is shown as a 24 hour clock e.g 19.30 not 7.30 PM.









### 6.11 REST

The REST function will **restore all factory set values**.

Any changes made to the displayed temperature, unit readings and controller value will be reset.

*Note* Calibration value in the TUNE option will remain and not be reset.

Follow these steps to navigate in the REST option.

Action	Key	Display
Press and hold UP+DOWN key for 3 seconds to enter the menu.  The option "UNIT" will appear in the display.		
Press DOWN key until the option "REST" appears in the display.		
Press and hold the setpoint key to change values.		
While holding the setpoint key in, press either the arrow UP or arrow DOWN key.  When the display shows "----", *let go of the setpoint key.		
Press and hold UP+DOWN key for 3 seconds to exit the menu.		

\*This means all factory values have now been restored.

## 7 User maintenance

### 7.1 Cleaning

The G85 is a low maintenance unit designed to be both easy to use and clean, plus it is durable due to its construction.

All surfaces should be cleaned with an 70% alcohol solution on a clean cloth or lint-free paper towel.

- Clean all surface components by wiping gently with gauze.
- To remove fingerprints or oil smudges, wipe with gauze slightly moistened with a mixture of ether (70%) and alcohol (30%).

*Note*        *Since solvents such as ether and alcohol are highly flammable, they must be handled carefully. Be sure to keep these chemicals away from open flames or potential sources of ignition – electrical equipment must be switched off. Also remember to always use these chemicals only in a well ventilated room.*

- If smudges are difficult to clean, wipe them with a soft cloth slightly moistened with a diluted neutral detergent.
- The heated area is able to withstand some water spills. However, precautions are still necessary if water is spilled on the surface. Unplug the power cord, and then wipe dry with a dry cloth immediately.

*Note*        *If water gets inside the unit, contact your K-SYSTEMS Kivex Biotec representative to check electrical safety.*

- Humidification bottle can be put in an autoclave.

### 7.2 Calibration

For optimal performance the unit should be calibrated once a year by authorized K-SYSTEMS Service provider.

## 8 Trouble shooting

Symptom	Cause	Action
Temperature alarm is on.	Temperature more than $\pm 0.5^{\circ}\text{C}$ from set temperature.	Check the set temperature. Wait for the temperature to stabilize.
No heating.	Setpoint below ambient.	Change setpoint (eg. $37^{\circ}\text{C}$ ).
Display remains off when "HEAT" key is activated.	No mains supply.	Plug in the power connector.
	Power connector, not connected.	Reconnect power connector.
	Defective "HEAT" key.	Replace the keyboard.
Flow alarm is on slow acoustic signal sounds and the display shows "-hi-".	The flow is higher than 29 l/h.	Reduce the flow.
Flow alarm is on. Fast acoustic signal sounds and display shows "f.on".	The flow is on and the heat is off	Turn the flow off.

## 9 Technical data

Material	Stainless steel (upper parts) Aluminium (lower parts)
Weight (without PSU and BLOCK)	5.4 kg
Overall dimensions (WxDxH)	267x340x95 mm
Temperature range	Ambient to 42° C
Spot temperature accuracy	± 0.2° C
Flow range	0 – 29 litres/hour
Power consumption	120 W
Heating	100 W
Gas consumption	0 – 29 litres/hour
Gas inlet pressure	0.3 – 0.5 Bar
PSU	AC input 100-240V 50-60Hz 1.6A MAX DC output 24V/5A
Alarms	Audible and visible for out of range temperature and air flow

## 10 Limited warranty

K-SYSTEMS Kivex Biotec warrants to the purchasers of all devices and products manufactured by K-SYSTEMS Kivex Biotec, the product was prepared and tested in accordance with good manufacturing practices and guidelines and are in compliance to the CE norms issued by the competent authority.

In the event of product failure under normal use, due to defects in material or workmanship, within a period of twenty four months from the date of shipment of the Product and from the point of origin, the product will be repaired, or at K-SYSTEMS Kivex Biotec option, replaced, at no charge. This limited warranty does not apply to products subjected to abnormal use or conditions, improper storage, damaged by accident, misuse or abuse, improper line voltage, products whose serial number has been altered, to products not shipped in accordance with the recommendations of K-SYSTEMS Kivex Biotec, and/or to products altered or serviced by anyone other than K-SYSTEMS Kivex Biotec authorised distributors. Distributor is responsible for the labour and travel costs during this period.

This limited warranty is exclusive and in lieu of all other warranties whether written, oral, expressed or implied. In particular, K-SYSTEMS Kivex Biotec does not warrant that the product is suitable for the needs of the purchaser and there are no warranties given as to merchantability or fitness for a particular purpose other than the one specified in K-SYSTEMS Kivex Biotec literature that accompanies every specific product. K-SYSTEMS Kivex Biotec assumes that the Purchaser is experienced in the use of this device and is able to judge from his/her own expertise the suitability or otherwise of the product for the intended use.

K-SYSTEMS Kivex Biotec reserves the right to change or discontinue this product without prior notice.

## 11 Liability

Because K-SYSTEMS Kivex Biotec has no control or influence over the conditions under which this device is used, over its method of use or administration, or on handling of the product after it leaves its possession, K-SYSTEMS Kivex Biotec takes no responsibility for the results, use and/or performance of the product. K-SYSTEMS Kivex Biotec expects that use of the product will be confined to trained and expert users.

In no event shall K-SYSTEMS Kivex Biotec be liable for any direct or indirect damages including incidental, consequential or special damages, arising out of or in connection with the use or performance of the product.

If K-SYSTEMS Kivex Biotec provides you with technical documentation, this does not authorise you to perform repairs, adjustments or alterations on the device or accessories.

No representative of K-SYSTEMS Kivex Biotec and no vendor of the product is authorised to change any of the foregoing terms and conditions, and the purchaser accepts the product subject to all terms and conditions herein, subject always to any contrary provisions which are necessarily implied by statute or law notwithstanding the within terms and conditions.

## 12 Replacement

As mentioned in the Limited Warranty, the decision whether to provide any remedy or whether to refund any portion of the purchase price shall be at the discretion of K-SYSTEMS Kivex Biotec.

Before returning a product for any reason, please contact your nearest K-SYSTEMS Kivex Biotec distributor for assistance and instructions.

Only for all customers in Denmark, Norway and Sweden, please take direct contact with our head office at:

Tel: +45 4599 5600

Fax: +45 4599 5619

Email: [info@k-systems.dk](mailto:info@k-systems.dk)