

Vacuum Pumps & Conveying System Components

Part Number: 882.000.31.00
Bulletin Number: WH2-605B.5
Effective: 12/12/12

Write Down Your Serial Numbers Here For Future Reference:

_____	_____
_____	_____
_____	_____

We are committed to a continuing program of product improvement.
Specifications, appearance, and dimensions described in this manual are subject to change without notice.

DCN No. _____
© Copyright 2012
All rights reserved.

Please note that our address and phone information has changed. Please reference this page for updated contact information.



These manuals are obsolete and are provided only for their technical information, data and capacities. Portions of these manuals detailing procedures or precautions in the operation, inspection, maintenance and repair of the products may be inadequate, inaccurate, and/or incomplete and shouldn't be relied upon. Please contact the ACS Group for more current information about these manuals and their warnings and precautions.

Parts and Service Department

The ACS Customer Service Group will provide your company with genuine OEM quality parts manufactured to engineering design specifications, which will maximize your equipment's performance and efficiency. To assist in expediting your phone or fax order, please have the model and serial number of your unit when you contact us. A customer replacement parts list is included in this manual for your convenience. ACS welcomes inquiries on all your parts needs and is dedicated to providing excellent customer service.

For immediate assistance, please contact:

- North, Central and South America, 8am – 5pm CST +1 (800) 483-3919 for drying, conveying, heating and cooling and automation. For size reduction: +1 (800) 229-2919.
North America, emergencies after 5pm CST (847) 439-5855
North America email: acsuscanadacustserv@corpemail.com
- Mexico, Central & South America
Email: acslatinamericacustserv@corpemail.com
- Europe, Middle East & Africa +48 22 390 9720
Email: acseuropecustserv@corpemail.com
- India +91 21 35329112
Email: acsindiacustserv@corpemail.com
- Asia/Australia +86 512 8717 1919
Email: acsasiacustserv@corpemail.com

Sales and Contracting Department

Our products are sold by a worldwide network of independent sales representatives. Contact our Sales Department for the name of the sales representative nearest you.

Let us install your system. The Contract Department offers any or all of these services: project planning; system packages including drawings; equipment, labor, and construction materials; and union or non-union installations.

For assistance with your sales or system contracting needs please Call:

North, Central and South America +1 (262) 641-8600 or +1 (847) 273-7700 Monday–Friday, 8am–5pm CST

Europe/Middle East/Africa +48 22 390 9720

India +91 21 35329112

Asia/Australia +86 512 8717 1919

Facilities:

ACS offers facilities around the world to service you no matter where you are located. For more information, please visit us at www.acscorporate.com

United States:

ACS Schaumburg – Corporate Offices

1100 E. Woodfield Road
Suite 588
Schaumburg, IL 60173
Phone: + 1 847 273 7700
Fax: + 1 847 273 7804

ACS New Berlin – Manufacturing Facility

2900 S. 160th Street
New Berlin, WI 53151
Phone : +1 262 641 8600
Fax: + 1 262 641 8653

Asia/Australia:

ACS Suzhou

109 Xingpu Road SIP
Suzhou, China 215126
Phone: + 86 8717 1919
Fax: +86 512 8717 1916

Europe/Middle East/Africa:

ACS Warsaw

Ul. Działkowa 115
02-234 Warszawa
Phone: + 48 22 390 9720
Fax: +48 22 390 9724

India

ACS India

Gat No. 191/1, Sandbhor Complex
Mhalunge, Chakan, Tal Khed,
Dist. Pune 410501, India
Phone: +91 21 35329112
Fax: + 91 20 40147576

Shipping Info

Unpacking and Inspection

You should inspect the mechanical components of your conveying system for possible shipping damage.

Thoroughly check the equipment for any damage that might have occurred in transit, such as broken or loose wiring and components, loose hardware and mounting screws, etc.

In the Event of Shipping Damage

According to the contract terms and conditions of the Carrier, the responsibility of the Shipper ends at the time and place of shipment.

Notify the transportation company's local agent if you discover damage.

Hold the damaged goods and packing material for the examining agent's inspection. **Do not return any goods before the transportation company's inspection and authorization.**

File a claim with the transportation company. Substantiate the claim by referring to the agent's report. A certified copy of our invoice is available upon request. The original Bill of Lading is attached to our original invoice. If the shipment was prepaid, write us for a receipted transportation bill.

Advise customer service regarding your wish for assistance and to obtain an RMA (return material authorization) number.

If the Shipment is Not Complete

Check the packing list as back-ordered items are noted on the packing list. You should have:

- Mechanical Components of Conveying System
- Bill of lading
- Packing list
- Operating and Installation packet
- Electrical schematic and panel layout drawings
- Component instruction manuals

Re-inspect the container and packing material to see if you missed any smaller items during unpacking.

If the Shipment is Not Correct

If the shipment is not what you ordered, **contact the shipping department immediately.** For shipments in the United States and Canada, call 1 (800) 423-3183; for all other countries, call our international desk at (414) 354-0970. Have the order number and item number available. *Hold the items until you receive shipping instructions.*

Returned Material Policy

Do not return any damaged or incorrect items until you receive shipping instructions from the shipping department.

Credit Returns

Prior to the return of any material authorization must be given by the manufacturer. A RMA number will be assigned for the equipment to be returned.

Reason for requesting the return must be given.

ALL returned material purchased from the manufacturer returned is subject to 15% (\$75.00 minimum) restocking charge.

ALL returns are to be shipped prepaid.

The invoice number and date or purchase order number and date must be supplied.

No credit will be issued for material that is not within the manufacturer's warranty period and/or in new and unused condition, suitable for resale.

Warranty Returns

Prior to the return of any material, authorization must be given by the manufacturer. A RMA number will be assigned for the equipment to be returned.

Reason for requesting the return must be given.

All returns are to be shipped prepaid.

The invoice number and date or purchase order number and date must be supplied.

After inspecting the material, a replacement or credit will be given, at the manufacturer's discretion. If the item is found to be defective in materials or workmanship, and it was manufactured by our company, purchased components are covered under their specific warranty terms.

Table of Contents

CHAPTER 1: SAFETY	6
1-1 How to Use This Manual	6
<i>Safety Symbols Used in this Manual</i>	6
1-2 Warnings and Precautions	8
1-3 Responsibility	9
<i>General Responsibility</i>	9
<i>Operator Responsibility</i>	10
<i>Maintenance Responsibility</i>	11
<i>Reporting a Safety Defect</i>	11
CHAPTER 2: FUNCTIONAL DESCRIPTION	12
2-1 Models Covered in This Manual	12
2-2 General Description	12
<i>Basic System Components</i>	12
<i>Basic System Types</i>	13
<i>Equipment Cycle</i>	13
2-3 Standard Features & Options	13
<i>Pumps</i>	13
<i>Atmospheric Valves</i>	17
<i>Sequence T-Valves</i>	18
<i>Filter Chambers</i>	19
<i>Pickup Tubes</i>	20
2-4 Safety Devices and Interlocks	21
CHAPTER 3: INSTALLATION	23
3-1 Uncrating the Equipment	23
3-2 Rigging and Placing Mechanical Components	24
<i>Installing the Pump Package</i>	24
<i>Installing the Control Panel</i>	25
<i>Installing Material/Vacuum Tubing</i>	25
<i>Installing FCA, FCK, or FCS Filter Chambers</i>	32
<i>Installing Vacuum Receivers and Inventory/Vacuum Receivers</i>	34
3-3 Compressed Air Connections	34
<i>Making Pump Compressed Air Connections</i>	34
3-4 Electrical Connections	34
<i>Making Pump Power Drop Wiring Connections</i>	34
<i>Making Control Panel Power Drop Wiring Connections</i>	35
<i>Connecting the Control Panel to the Pump Package</i>	35
3-5 Initial Start-up	36
<i>Making Startup Checks</i>	36
CHAPTER 4: OPERATION	37
4-1 Start-up	37
4-2 Operation Procedures	37
<i>Vacuum Switch (VS) Operation</i>	37

	<i>High Vacuum Relief Regulator Operation</i>	38
4-3	Shut-down.....	38
CHAPTER 5: MAINTENANCE.....		39
5-1	Preventative Maintenance Schedule.....	39
5-2	Preventative Maintenance	40
	<i>Maintaining Pump Packages</i>	40
CHAPTER 6: TROUBLESHOOTING.....		41
6-1	Introduction	41
CHAPTER 7: APPENDIX		48
7-1	Warranty	48
7-2	Technical Specifications	49
	<i>Annex B Information</i>	49
7-3	Spare Parts List.....	50
7-4	Identification (Serial Number) Tag	53
7-5	Technical Assistance.....	54
	<i>Parts Department</i>	Error! Bookmark not defined.
	<i>Service Department</i>	Error! Bookmark not defined.
	<i>Sales Department</i>	Error! Bookmark not defined.
	<i>Contract Department</i>	Error! Bookmark not defined.

Chapter 1: Safety

1-1 How to Use This Manual

Use this manual as a guide and reference for installing, operating, and maintaining the mechanical components of your conveying system. The purpose is to assist you in applying efficient, proven techniques that enhance equipment productivity.

This manual covers only light corrective maintenance. No other maintenance should be undertaken without first contacting a service engineer.

The Functional Description section outlines models covered, standard features, and safety features. Additional sections within the manual provide instructions for installation, pre-operational procedures, operation, preventive maintenance, and corrective maintenance.

The Installation chapter includes required data for receiving, unpacking, inspecting, and setup of the mechanical components of your conveying system. We can also provide the assistance of a factory-trained technician to help train your operator(s) for a nominal charge. This section includes instructions, checks, and adjustments that should be followed before commencing with operation of the conveying system. These instructions are intended to supplement standard shop procedures performed at shift, daily, and weekly intervals.

The Operation chapter includes a description of electrical and mechanical controls, in addition to information for operating the conveying system safely and efficiently.

The Maintenance chapter is intended to serve as a source of detailed assembly and disassembly instructions for those areas of the equipment requiring service. Preventive maintenance sections are included to ensure that the mechanical components of your conveying system provide excellent, long service.

The Troubleshooting chapter serves as a guide for identification of most common problems. Potential problems are listed, along with possible causes and related solutions.

The Appendix contains technical specifications, drawings, schematics, parts lists, and available options. A spare parts list with part numbers specific to your machine is provided with your shipping paperwork package. Refer to this section for a listing of spare parts for purchase. Have your serial number and model number ready when ordering.

Safety Symbols Used in this Manual

The following safety alert symbols are used to alert you to potential personal injury hazards. Obey all safety messages that follow these symbols to avoid possible injury or death.

DANGER! *DANGER indicates an imminently hazardous situation that, if not avoided, will result in death or serious injury.*

WARNING! *WARNING indicates a potentially hazardous situation or practice that, if not avoided, could result in death or serious injury.*

Caution! *CAUTION indicates a potentially hazardous situation or practice that, if not avoided, may result in minor or moderate injury or in property damage.*

Conveying System Safety Tags



Spraying
Hazard



Read Operation
and Installation
Manual



High Voltage
Inside Enclosure



Earth Ground



Lifting Point



Protected Earth
Ground

1-2 Warnings and Precautions

Our equipment is designed to provide safe and reliable operation when installed and operated within design specifications, following national and local safety codes. This may include, but is not limited to OSHA, NEC, CSA, SPI, and any other local, national and international regulations.

To avoid possible personal injury or equipment damage when installing, operating, or maintaining this equipment, use good judgment and follow these safe practices:

- ☑ Read and follow these operation and installation instructions when installing, operating, and maintaining this equipment. If these instructions become damaged or unreadable, additional copies are available from the manufacturer.
- ☑ Follow all **SAFETY CODES**.
- ☑ Wear **SAFETY GLASSES** and **WORK GLOVES**.
- ☑ Work only with approved tools and devices.
- ☑ Disconnect and/or lock out power before servicing or maintaining the equipment.
- ☑ Use care when **LOADING, UNLOADING, RIGGING, or MOVING** this equipment.
- ☑ Operate this equipment within design specifications.
- ☑ **OPEN, TAG, and LOCK ALL DISCONNECTS** before working on equipment. You should remove the fuses and carry them with you.
- ☑ Make sure the equipment and components are properly **GROUNDING** before you switch on power.
- ☑ Use extreme caution when working with your conveying system. **HIGH VACUUM** can be dangerous. Keep body parts, tools, clothing, and debris away from vacuum inlets.

- ☑ When welding or brazing in or around this equipment, make sure **VENTILATION** is **ADEQUATE**. **PROTECT** adjacent materials from flame or sparks by shielding with sheet metal. An approved **FIRE EXTINGUISHER** should be close at hand and ready for use if needed.
- ☑ Do not restore power until you remove all tools, test equipment, etc., and the equipment and related components are fully reassembled.
- ☑ Only **PROPERLY TRAINED** personnel familiar with the information in this manual should work on this equipment.

We have long recognized the importance of safety and have designed and manufactured our equipment with operator safety as a prime consideration. We expect you, as a user, to abide by the foregoing recommendations in order to make operator safety a reality.

1-3 Responsibility

These machines are constructed for maximum operator safety when used under standard operating conditions and when recommended instructions are followed in the maintenance and operation of the machine.

All personnel engaged in the use of the machines should become familiar with their operation as described in this manual.

Proper operation of the machine promotes safety for the operator and all workers in its vicinity.

Each individual must take responsibility for observing the prescribed safety rules as outlined. All warning and danger signs must be observed and obeyed. All actual or potential danger areas must be reported to your immediate supervisor.

General Responsibility

No matter who you are, safety is important. Owners, operators and maintenance personnel must realize that every day, safety is a vital part of their jobs.

If your main concern is loss of productivity, remember that production is always affected in a negative way following an accident. The following are some of the ways that accidents can affect your production:

- Loss of a skilled operator (temporarily or permanently)
- Breakdown of shop morale
- Costly damage to equipment
- Downtime

An effective safety program is responsible and economically sound.

Organize a safety committee or group, and hold regular meetings. Promote this group from the management level. Through this group, the safety program can be continually reviewed, maintained, and improved. Keep minutes or a record of the meetings.

Hold daily equipment inspections in addition to regular maintenance checks. You will keep your equipment safe for production and exhibit your commitment to safety.

Please read and use this manual as a guide to equipment safety. This manual contains safety warnings throughout, specific to each function and point of operation.

Operator Responsibility

The operator's responsibility does not end with efficient production. The operator usually has the most daily contact with the equipment and intimately knows its capabilities and limitations.

Plant and personnel safety is sometimes forgotten in the desire to meet incentive rates, or through a casual attitude toward machinery formed over a period of months or years. Your employer probably has established a set of safety rules in your workplace. Those rules, this manual, or any other safety information will not keep you from being injured while operating your equipment.

Learn and always use safe operation. Cooperate with co-workers to promote safe practices. Immediately report any potentially dangerous situation to your supervisor or appropriate person.

REMEMBER:

- **NEVER** place your hands or any part of your body in any dangerous location.
- **NEVER** operate, service, or adjust the conveying system without appropriate training and first reading and understanding this manual.
- **NEVER** try to pull material out of the conveying system with your hands while it is running!
- Before you start the conveying system, check the following:
 - Remove all tools from the conveying system;
 - Be sure no objects (tools, nuts, bolts, clamps, bars) are laying in the area;
- If your conveying system has been inoperative or unattended, check all settings before starting the unit.
- At the beginning of your shift and after breaks, verify that the controls and other auxiliary equipment are functioning properly.
- Keep all safety guards in place and in good repair. **NEVER** attempt to bypass, modify, or remove safety guards. Such alteration is not only unsafe, but will void the warranty on your equipment.
- When changing control settings to perform a different mode of operation, be sure selector switches are correctly positioned. Locking selector switches should only be adjusted by authorized personnel and the keys removed after setting.
- Report the following occurrences **IMMEDIATELY**:
 - unsafe operation or condition
 - unusual conveying system action
 - leakage
 - improper maintenance
 - **NEVER** stand or sit where you could slip or stumble into the conveying system while working on it.

- **DO NOT** wear loose clothing or jewelry, which can be caught while working on the conveying system. In addition, cover or tie back long hair.
- Clean the conveying system and surrounding area **DAILY**, and inspect the machine for loose, missing or broken parts.
- Shut off power to the conveying system when it is not in use. Turn the switch to the **OFF** position, or unplug it from the power source.

Maintenance Responsibility

Proper maintenance is essential to safety. If you are a maintenance worker, you must make safety a priority to effectively repair and maintain equipment.

Before removing, adjusting, or replacing parts on a machine, remember to turn off all electric supplies and all accessory equipment at the machine, and disconnect and lockout electrical and pneumatic power. Attach warning tags to the disconnect switch and air shutoff valve.

When you need to perform maintenance or repair work on a conveying system above floor level, use a solid platform or a hydraulic elevator. If there is a permanently installed catwalk on your conveying system, use it. The work platform should have secure footing and a place for tools and parts. **DO NOT** climb on the conveying system, machines, or work from ladders.

If you need to repair a large component, use appropriate handling equipment. Before you use handling equipment (portable “A” frames, electric boom trucks, fork trucks, overhead cranes) be sure the load does not exceed the capacity of the handling equipment or cause it to become unstable.

Carefully test the condition of lifting cables, chains, ropes, slings, and hooks before using them to lift a load.

Be sure that all non-current carrying parts are correctly connected to earth ground with an electrical conductor that complies with current codes. Install in accordance with national and local codes.

When you have completed the repair or maintenance procedure, check your work and remove your tools, rigging, and handling equipment.

Do not restore power to the conveying system until all persons are clear of the area. **DO NOT** start and run the conveying system until you are sure all parts are functioning correctly.

BEFORE you turn the conveying system over to the operator for production, verify all enclosure panels, guards and safety devices are in place and functioning properly.

Reporting a Safety Defect

If you believe that your equipment has a defect that could cause injury, you should immediately discontinue its use and inform the manufacturer.

The principle factors that can result in injury are failure to follow proper operating procedures (i.e. lockout/tagout), or failure to maintain a clean and safe working environment.

Chapter 2: Functional Description

2-1 Models Covered in This Manual

This manual provides operation, installation, and maintenance instructions for the mechanical components of the conveying system. Model numbers are listed on the serial tag. Make sure you know the model and serial number of your equipment before contacting the manufacturer for parts or service.

Our mechanical components are designed to create vacuum for conveying pelletized, granular, or powder material in a central material handling system. A typical use is as an in-plant distribution system for plastic processing plants. Conveying system mechanical components are sized to meet the specific requirements stated by the Customer at the time of purchase.

2-2 General Description

Our central vacuum systems are as varied as the applications that they service. Tubing and equipment furnished in a specially designed system is intended to convey the material(s) specified at the time of purchase at specific rates and distances.

We can advise you on your system capabilities based on system makeup, distance, material, and desired conveying rates.

Pressure drops in the overall system directly affect system capacity, such as number of material line bends, footage of pipe, Y-tubes, T-tubes, etc.

The less distance, flexible hose, and bends you use on material lines, the better. Keep material lines as straight as possible.

Note: Vacuum leaks occurring anywhere in your system reduce capacity.

Basic System Components

A typical conveying system contains the following components:

- Vacuum receiver(s)
- Vacuum pump
- Filter chamber
- Sequence or atmospheric valves
- Controller
- Take-off compartments
- Pickup tubes/wands
- Vacuum and material tubing

Combinations of these components will help you build your system for the application you need.

Basic System Types

Time-Fill Systems

A *time-fill system* conveys material to an on-line vacuum receiver for a pre-set time period. When this interval elapses, the controller conveys material to the next on-line vacuum receiver.

Volume-Fill Systems

A *volume-fill system* conveys material to an on-line vacuum receiver until the material level activates the proximity switch in the vacuum receiver, or a preset time elapses. When either of these conditions occur, the controller conveys material to the next on-line vacuum receiver.

Equipment Cycle

Our bulk material conveying systems are used for automatic pneumatic handling of most free-flowing, dry, pelletized, powder granular materials.

Material characteristics determine the type of equipment needed to properly convey the material.

See Figures 7 and 11 on Pages 25 and 28 for typical system configurations.

2-3 Standard Features & Options

Pumps

5, 10 & 15 Hp Positive Displacement

- Support base.
- Positive displacement blower.
- 3-phase high efficiency TEFC electric motor.
- 5, 10, or 15 horsepower (3.75, 7.5, 11.25 kW).
- Standard voltage is 230-460/3/60, 380-415/3/50, 220/3/50 and 575/3/60 optional.
- Adjustable motor base.
- Compressed air-operated mechanical high-vacuum relief valve.
- Vacuum gauge.
- Vacuum switch for high vacuum protection.
- Junction box with motor starter, including overload protection.
- Discharge silencer.

Options

- Sound enclosure.
- Premium-efficiency motors.

Figure 1: Positive Displacement Pump Dimensions

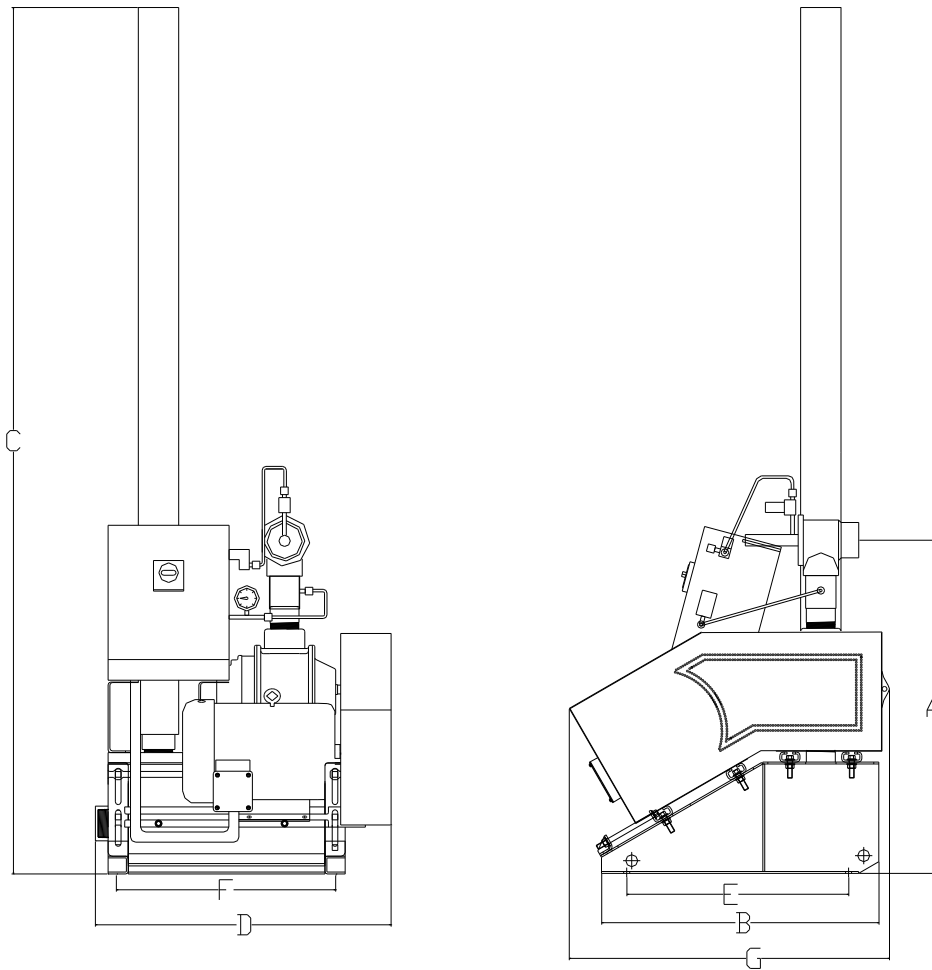

Unit size	Dimensions (inches)						
hp	A	B	C	D	E	F	G
5	33	27.5	85.82	29	22	21.75	31.75
10							
15							

Unit size	Dimensions (cm)						
kW	A	B	C	D	E	F	G
3.75	84	70	218	74	56	55	81
7.5							
11.25							

3.5, 6.5 & 11 Hp Centrifugal Pumps

- Centrifugal blower.
- Cartridge filter.
- Vent valve
- Junction box with starter mounted on unit.

Figure 2: Centrifugal Pump Dimensions

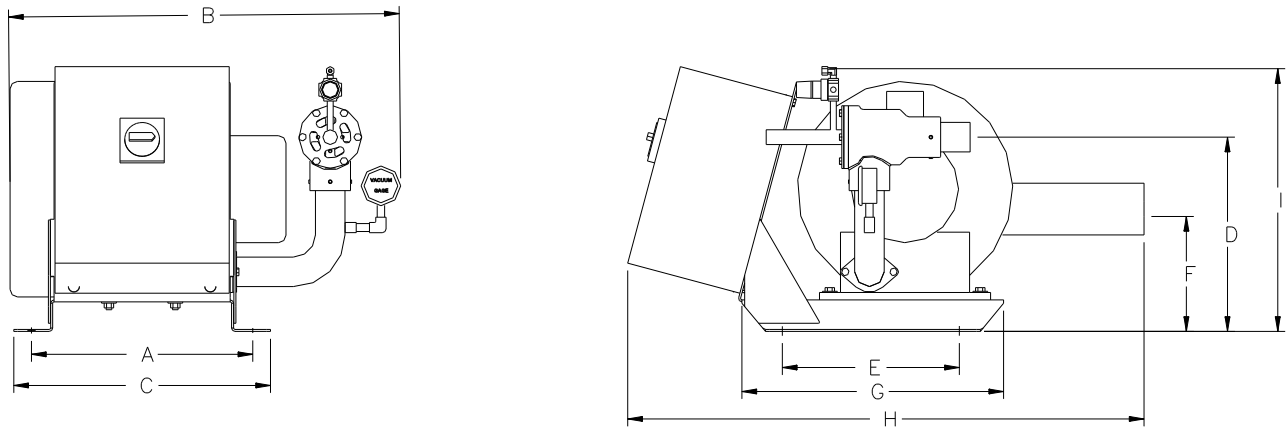

Unit size	Dimensions (inches)								
hp	A	B	C	D	E	F	G	H	I
3.5	15	26.25	17.4	13	12	8.75	17.75	35	18
5		24.5		13		7.5		31	17.75
11.0		31.5		14.8		8.6		35.5	19

Unit size	Dimensions (cm)								
kW	A	B	C	D	E	F	G	H	I
2.63	38	67	44	33	30	22	45	89	46
4.84		62		33		19		79	45
8.20		80		37		21		90	48

Figure 3: Pump Specifications

Model hp	Amp draw, full-load amps			Air flow ① cfm	Line size inches		Ship weight lbs.
	230 V	460 V	575 V		Vacuum	Material	
<i>Pumps — Positive Displacement Models</i>							
5	13.4	6.7	5.4	120	2.0"	2.0"	385
10	28.4	14.2	11.4	200	2.5"	2.5"	400
15	38.4	19.2	15.3	300	3.0"	3.0"	420
<i>Pumps — Centrifugal Models</i>							
3.5	9.1	4.6	3.0	106	2.0"	1.5"	175
6.5	12.9	6.5	4.3	152	2.0"	2.0"	300
11	32.5	16.2	10.6	225	2.5"	2.5"	350

Model kW	Amp draw, full-load amps			Air flow ① cmh	Line size mm	Ship weight Kg
	230 V	460 V	575 V			
<i>Pumps — Positive Displacement Models</i>						
3.75	13.4	6.7	5.4	204	50 mm	175
7.5	28.4	14.2	11.4	340	63 mm	181
11.25	38.4	19.2	15.3	510	76 mm	190
<i>Pumps — Centrifugal Models</i>						
3.5	9.1	4.6	3.0	180	38 mm	80
6.5	12.9	6.5	4.3	258	50 mm	136
11	32.5	16.2	10.6	302	63 mm	159

① Air flow measured in cubic feet per minute (cfm) and cubic meters per hour (cmh).

Note: *Rated performance is at standard atmosphere and sea level conditions.
High elevation affects system performance.*

Atmospheric Valves

Models AV1.5, AV2, AV2.25, AV2.5, AV3

- Mount on cover of vacuum hopper to direct vacuum into hoppers.
- Relieves vacuum by allowing an in-rush of atmospheric air into the system.
- Compressed air-operated.
- Selection of black or white neoprene plungers or available high temperature plungers.
- 24 VDC control voltage solenoid.
- Adds only inches to the height of vacuum hoppers and filter chambers.

Figure 4: Typical Atmospheric Valves

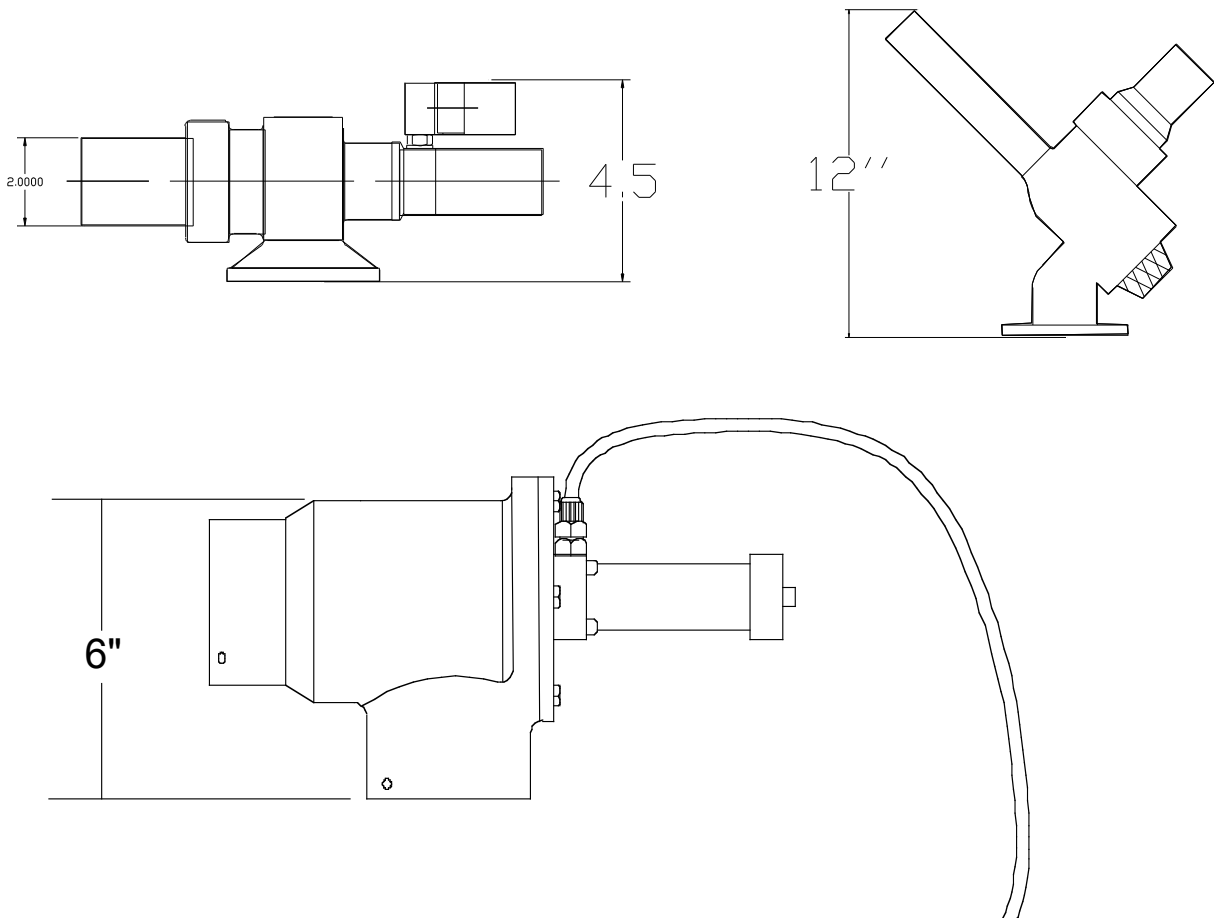

Sequence T-Valves

Models SV1.5, SV2, SV2.25, SV2.5, SV3, SV4, SV4.5, SV5

- Mount in vacuum header piping above vacuum hoppers to direct vacuum into hoppers.
- Compressed air operation.
- Selection of black or white neoprene plungers, or high temperature silicone plungers.
- 24 VDC control voltage solenoid.

Figure 5: Typical Sequence T-Valve

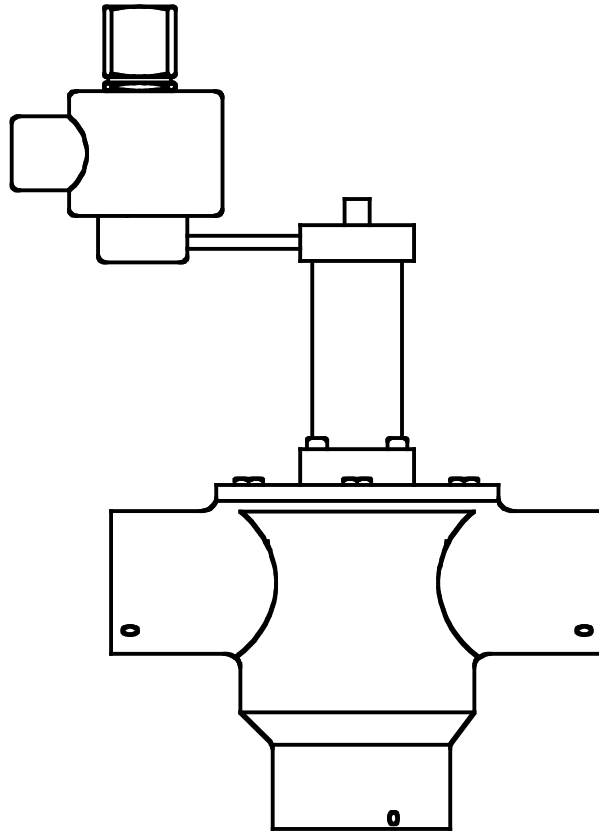

Filter Chambers

Specific Features on K Models

- 24 VDC
- Filter surface of 3.2 sq. ft. (0.3 m²).
- Compressed air filter cleaning.
- 2" connections
- Weight Approx. 31 lbs. (14 kg)

Specific Features on A Models

- 24 VDC
- Filter surface of 17.2 sq. ft. (1.6 m²).
- Implosion filter cleaning.
- 2.5" connections
- Weight Approx. 117 lbs. (53 kg)

Specific Features on S Models

- 24 VDC or 110 V
- Filter surface of 50 sq. ft. (4.6 m²).
- Compressed air and implosion filter cleaning.
- 2", 2.5", or 3" connections

Common Features on All Models: K, A, S

- For use with Positive Displacement power units.
- Twenty-six inch (26"/66 cm) -high floor stand for drum discharge.
- Reverse pulse filter element.
- Available in floor-mount, wall mount or pump mount configurations.
- Spare filter cartridge available.

Figure 6: A, K, or S Series; Filter Chamber Specifications and Dimensions

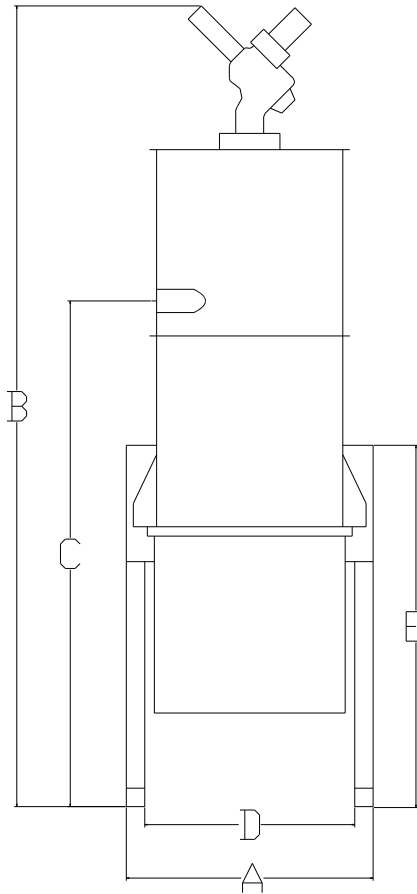

A	Floor Stand	A		B		C		D		E	
		inches	cm	inches	cm	inches	cm	inches	cm	inches	cm
	26 (66)	16.5	42	54.5	138	34.3	87	14.25	36	26	66

K	Floor Stand	A		B		C		D		E	
		Inches	cm	inches	cm	inches	cm	inches	cm	inches	cm
	26 (66)	13.3	34	45	114	32.3	82	11	28	26	66
S	26 (66)	13	33	34.5	88	32	81	10.25	26	26	66

Note: Dimensions are approximate and subject to change without notice.

Pickup Tubes

Take-Off Compartment Models:

Single and dual tube take-off compartments are available.

Pickup Tube Models:

Single and dual tube pickup tubes available.

2-4 Safety Devices and Interlocks

This section includes information on safety devices and procedures that are inherent to the mechanical components of the conveying system. This manual is not intended to supersede or alter safety standards established by the user of this equipment. Instead, the material contained in this section is recommended to supplement these procedures in order to provide a safer working environment.

At the completion of this section, the operator and maintenance personnel will be able to do the following:

- Identify and locate specific safety devices.
- Understand the proper use of the safety devices provided.
- Describe the function of the safety device.

Safety Circuit Standards

Safety circuits used in industrial systems protect the operator and maintenance personnel from dangerous energy. They also provide a means of locking out or isolating the energy for servicing equipment.

Various agencies have contributed to the establishment of safety standards that apply to the design and manufacture of automated equipment. The Occupational Safety and Health Administration (OSHA) and the Joint Industrial Council (JIC) are just a few of the organizations that have joined with the plastics industry to develop safety standards.

Every effort has been made to incorporate these standards into the design of the mechanical components of the conveying system; however, it is the responsibility of the personnel operating and maintaining the equipment to familiarize themselves with the safety procedures and the proper use of any safety devices.

Fail Safe Operation

If a safety device or circuit should fail, the design must be such that the failure causes a “Safe” condition. As an example, a safety switch must be a normally open switch. The switch must be held closed with the device it is to protect. If the switch fails, it will go to the open condition, tripping out the safety circuit.

At no time should the safety device fail and allow the operation to continue. For example, if a safety switch is guarding a motor, and the safety switch fails, the motor should not be able to run.

Safety Device Lock-Outs

Some safety devices disconnect electrical energy from a circuit. The safety devices that are used on the mechanical components of the conveying system are primarily concerned with electrical power disconnection and the disabling of moving parts that may need to be accessed during the normal operation of the machines.

Some of the safety devices utilize a manual activator. This is the method of initiating the safety lock out. This may be in the form of a plug, lever or a handle. Within this lockable handle, there may be a location for a padlock. Personnel servicing the equipment should place a padlock in the lockout handle.

In addition to the safety devices listed above, these mechanical components are equipped with a line cord plug. This allows the operator or maintenance personnel to unplug the system from its power source and tag it out. The plug can then be tagged with any number of approved electrical lockout tags available at most electrical supply stores.

WARNING! *Always disconnect and lockout all electrical power and pneumatic (i.e. compressed air) sources prior to servicing or cleaning the conveying system. Failure to do so may result in serious injury. No one but the person who installed the lockout may remove it.*



Chapter 3: Installation

3-1 Uncrating the Equipment

The mechanical components of the conveying system are shipped mounted on a skid, enclosed in a plastic wrapper, and contained in a cardboard box.

1. Pry the crating away from the skid.

Note: *Remove the nails holding the box to the skid and lift the box off carefully; avoiding staples in the 1' x 4' wood supports. Cut the steel banding.*

2. Use a pry bar to remove the blocks securing the unit to the skid.
3. Lift unit from sides, inserting forklift under the base. The forks must be equidistant from the centerline of the unit and the unit must be balanced on the forks. Lift slowly and only high enough to clear the skid. Use a pry bar if necessary to carefully remove the skid from the unit.
4. Lower slowly.
5. Temporary hardware has been installed to prevent side panels from shifting in transit. Remove hardware.
6. Retain the crating material for reshipping the components in case hidden shipping damage is found.

3-2 Rigging and Placing Mechanical Components

Conveying system installations vary depending on the application: in-plant distribution or rail car unloading, single or multiple material line systems, pellets, or powders. The sections on the following pages are general installation guidelines.

Installing the Pump Package

Place the vacuum pump where you can have easy access to the mechanical components. Choose a clean, dry place where debris won't be drawn into the vent valve on top of the blower. If you install the unit outside, you must provide a weather shed to shelter the unit.

1. Level the vacuum pump package. Use shims as needed.
2. Secure the vacuum pump package with appropriately-sized bolts to the floor or mounting platform.
3. Do not twist or warp the pump package base. This can misalign the blower housing and damage the blower.

Vacuum Pump Vent Piping Considerations

Most vacuum pumps are installed with no exhaust venting of the vacuum pump discharge. If your installation requires vacuum pump exhaust venting, follow these guidelines:

- Venting exhaust air from vacuum pumps requires the installation of metal pipe or ducting. Make sure that no more than two inches water column (2" WC or about 0.5 kPa) back pressure is present at the discharge of the vacuum pump silencer.

Note: Improper sizing or ducting of exhaust air voids your warranty!

- Use piping or ducting at least two (2) diameter sizes larger than the vacuum connection. Overall vent pipe length—horizontal plus vertical—should not exceed 100 feet (about 30 m) and should not include more than three (3) elbows. If you use pipe for venting, make sure that you use Sch. 5 or Sch. 10 pipe with long radius elbows to provide minimum airflow resistance. If you use ducting, make sure you use high-pressure ducting with mitered bends—with a minimum of three (3) breaks—for minimum airflow resistance. Make sure all piping connections are properly supported.
- If you are venting pump discharge outdoors, make sure you properly terminate vent piping to prevent pump damage. You can either:
 - a. Install a rain cap, or
 - b. Install the piping so the exhaust faces down and terminates with a screened opening.

Note: If the pump becomes contaminated from rain or airborne particulates, or is damaged by birds, insects, or small animals, your warranty becomes void!

Any variance from these guidelines can cause excessive pump back pressure. Such a condition can drastically affect equipment performance, possibly leading to equipment damage.

Installing the Control Panel

Select a flat, vertical area for mounting the panel. It should be in an area that gives your operator access to the control. Consider how you are running wiring to the vacuum hoppers, the filter chamber, and pump motor starter(s), vacuum switch(es), and vent valve(s). The panel requires a low voltage grounded power drop as listed on the serial tag.

Note: *Avoid mounting control panel near material lines.*

Installing Material/Vacuum Tubing

Well-designed material/vacuum piping systems provide the best conveying rates. Vacuum/material piping may be a single material line Y system or multiple material line or a combination of the two systems (See figures 8-10 on page 26 and 27 for examples), depending on the processing floor layout. All systems utilize a common vacuum header line for all stations connected to a pump package; material flow is controlled by sequence T or atmospheric valves operated by the control panel. When installing material/vacuum tubing, take the following into consideration:

- Vacuum leaks anywhere in the system reduce system capacity.
- Keep the number of material tube bends, elbows, Y-tubes, and vacuum T-tubes to a minimum for maximum system capacity.
- Use long radius tube bends on material lines.
- Keep the total length of material conveying flex hose to a minimum. Long flex hose material runs reduce system capacity.
- Vertical material tubing runs should be straight up. Inclined runs can reduce capacity.
- Support tubing about every ten feet with straps, pipe hangers, or brackets.
- Tube joints must be rigid to prevent vacuum or material leaks.
- Cut tube ends square and chamfer edges smooth. Use a fixed band saw or power miter saw when making cuts. You can use a tubing cutter on aluminum tubing, but you need to use a saw with a carbide or diamond-impregnated saw blade when cutting stainless steel. Chamfer outer and inner edge cuts with a die grinder or a hardened rasp file.
- Clean all tubing after cutting and before assembly. Dampen a rag in a non-volatile cleaning solvent, and run it through all tubing and couplers to remove sediment from shipping or cutting. Run a quantity of low-grade material through new lines to remove any remaining sediment, then discard the material immediately.
- Tube ends must butt together inside couplers.
- Tighten tube coupler nuts from the center outward to ensure a tight seal and allow proper contact of the internal grounding strip.
- Each material tubing run must maintain an electrical continuity through the tubing and couplers, from pickup point to vacuum hopper. Grounded flexible hose is recommended.
- If you must cut bends, cut the straight section, leaving enough straight length for complete insertion into a coupler.
- You can attach a quick-change or standard tube coupler to vinyl flex hose by inserting a stub of hard tube into the hose and securing it with a hose clamp. Be sure enough

tube extends from the hose to properly install the quick-change or coupler. Make sure that you put clear silicone caulk around adjoining tube seams for exterior bolted couplers.

- If you use stainless flexible material hose, the material flow must be in the direction as indicated by the arrows on the hose. Material direction is not critical with vinyl flex hose.
- Bring all truck fill lines to a central location, such as a silo, unless otherwise specified.
- All rail car manifold Y-tubes must be installed with a ten-degree (10°) downward slant from horizontal on the leg section. Make sure that space between rail car manifold Y-tubes are fifteen feet (15'/4.5 meters) on center to allow proper alignment between rail car discharge ports and the manifold Y-tubes.
- A plug must be put in the last sequence T valve on the vacuum header to prevent vacuum loss. If atmospheric valves are used, you must terminate the vacuum line at the last atmospheric valve.

Multiple Line System Piping Considerations

- Multiple line systems have separate material lines for each material to allow different types of materials to be conveyed.
- Multiple line systems have separate pickup devices for each vacuum hopper.
- Materials are often loaded from beside the processing machine from gaylords, grinder takeoffs, and storage bin takeoffs.

Figure 7: Typical Multiple Line System Installation

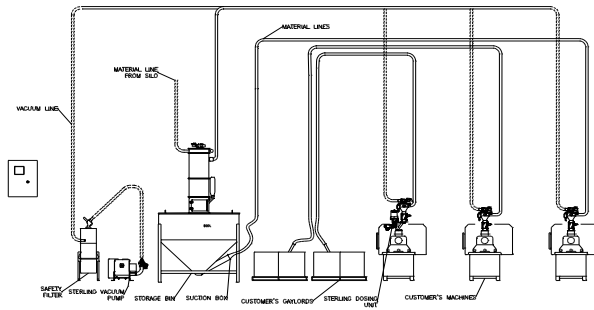

Single Line Y-Tube System Considerations

- Single line Y piping systems use a common material line for all vacuum receivers connected to a pump and are typically used to convey material from a central supply to several stations.
- If you are installing a single line Y system, use Y tubes on the material lines. A Y tube is installed with the branch arm leading to the next station on top and the straight portion that supplies material to the station underneath.
- Connect a short-radius bend to the straight portion as close to the Y as possible.
- You must connect a minimum 2-foot (61 cm) straight length of tube to this short radius bend on the horizontal before the material tubing drops to the receiving point. If possible, incline this tube approximately $\frac{1}{8}$ " per foot (1 cm per meter).
- On single line Y systems, you must install check valves on material inlet tubes inside vacuum receivers.
- You can install a long- or short-radius bend on the last station, where a Y-tube is not needed.

Figure 8: Recommended Single-Line Y-Tube Installation

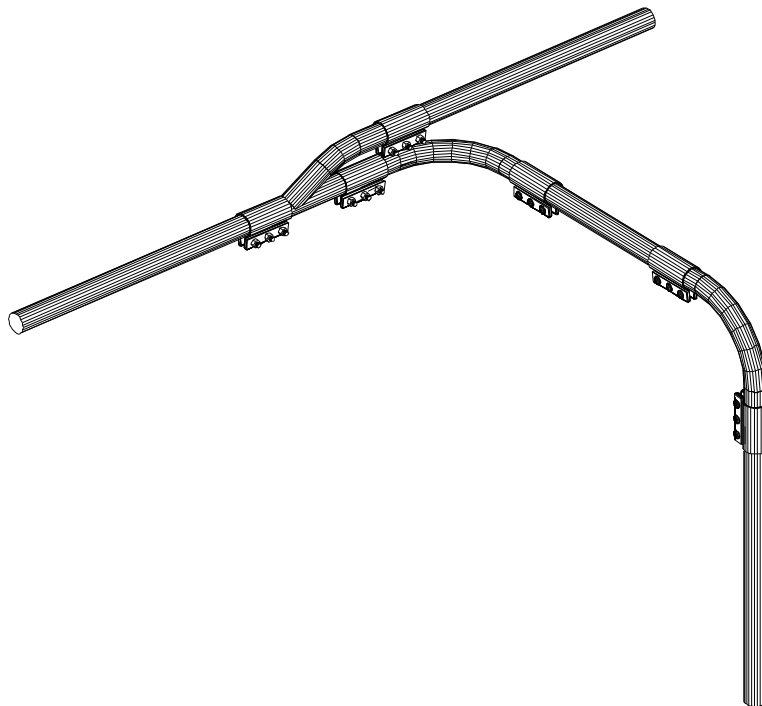

Figure 9: Modified Single-Line Y-Tube Installation

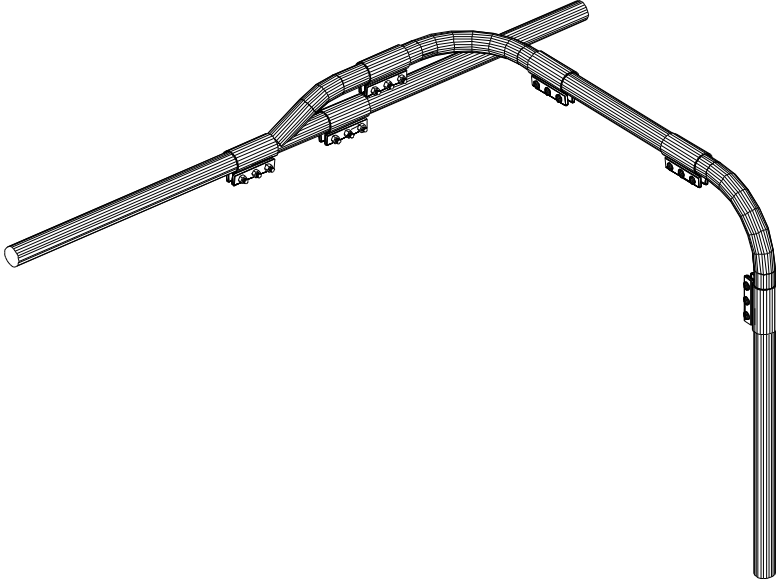

Figure 10: Manifold Y-Tube Installation

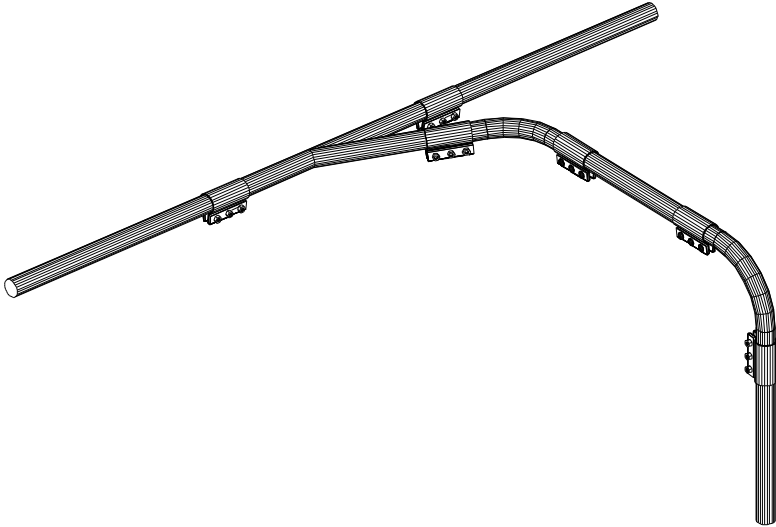
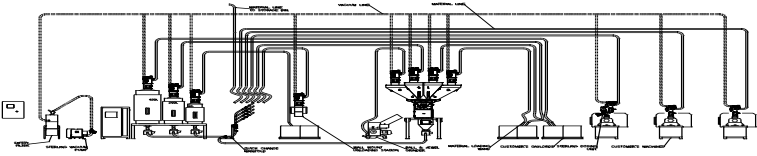

Figure 11: Typical Single-Line Y-Tube Installation



Material Check Valves in Single Line Y-Tube Systems

- Check valves are a critical feature on single line Y systems. You must have a check valve installed on the material inlet inside the receiver on all vacuum hoppers in single line Y installations.
- Check valves must open when the receiver is being loaded and seal to prevent a vacuum leak when other hoppers are being loaded.
- Vacuum receivers for these systems have a special factory-installed extended material inlet tube to hold the check valve.
- The check valve must not be pressed too far onto the inlet stub to prevent proper sealing.
- The hinge of the check valve should be up to prevent material from being deflected up into the vacuum hopper filter.
- Do not allow vacuum receivers with check valves to be over-filled to a point above the bottom of the check valve. Over-filling prevents the check valve from sealing and creates a vacuum loss. Adjust the conveying time on Time-Fill systems to prevent this from happening.
- Inspect periodically for erosion or wear. Replace as required.

Figure 12: Typical Material Check Valve

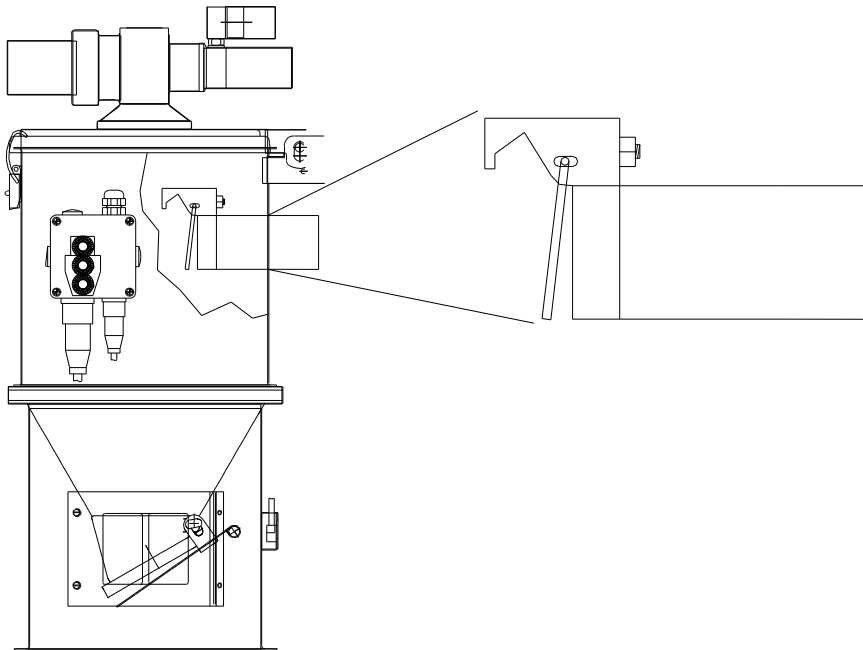

Installing A, K, or S Filter Chambers

The filter chamber protects the vacuum pump from damage caused by material carry-over. Primary system filtration occurs in the filter chamber, not in the vacuum receivers. This reduces maintenance of vacuum receiver filters atop processing machines.

At the end of the conveying cycle to all on-line vacuum receivers, the dump delay cycle occurs. Atmospheric air from the vacuum line is introduced to the filter chamber, equalizing the pressure inside the filter chamber. The material discharge flapper valve falls open and dumps the fines and dust collected during the conveying cycle.

The K Filter Chamber utilizes compressed air as a means of filter cleaning. The A Filter Chamber does the same, except utilizes implosion cleaning. The S is able to clean the filter by either method.

A compressed air filter cleaning blow back option is available for systems conveying very dusty materials. Consult the Sales Department for more information.

Level and secure the filter chamber near the pump package. Use $\frac{3}{8}$ " (9 mm) bolts to anchor the filter chamber.

1. Connect the piping between the vacuum inlet valve on the pump package and the tube stub on the filter chamber lid. For easy filter maintenance, install at least three feet (3' / 1 m) of vinyl flex hose at the end of the run to the filter chamber. The rest may be hard piping as long as it is properly supported.
2. Run vacuum tubing from the tangential inlet tube to the vacuum header line servicing the vacuum hoppers. Turn the inlet tube toward the header. Support the tubing properly and make it vacuum-tight.

Note: Use of a system without a manufacturer-approved filter system installed on the vacuum air inlet voids the blower warranty!

Figure 13: Filter Chamber Installation, Optional Blowback Controller Shown

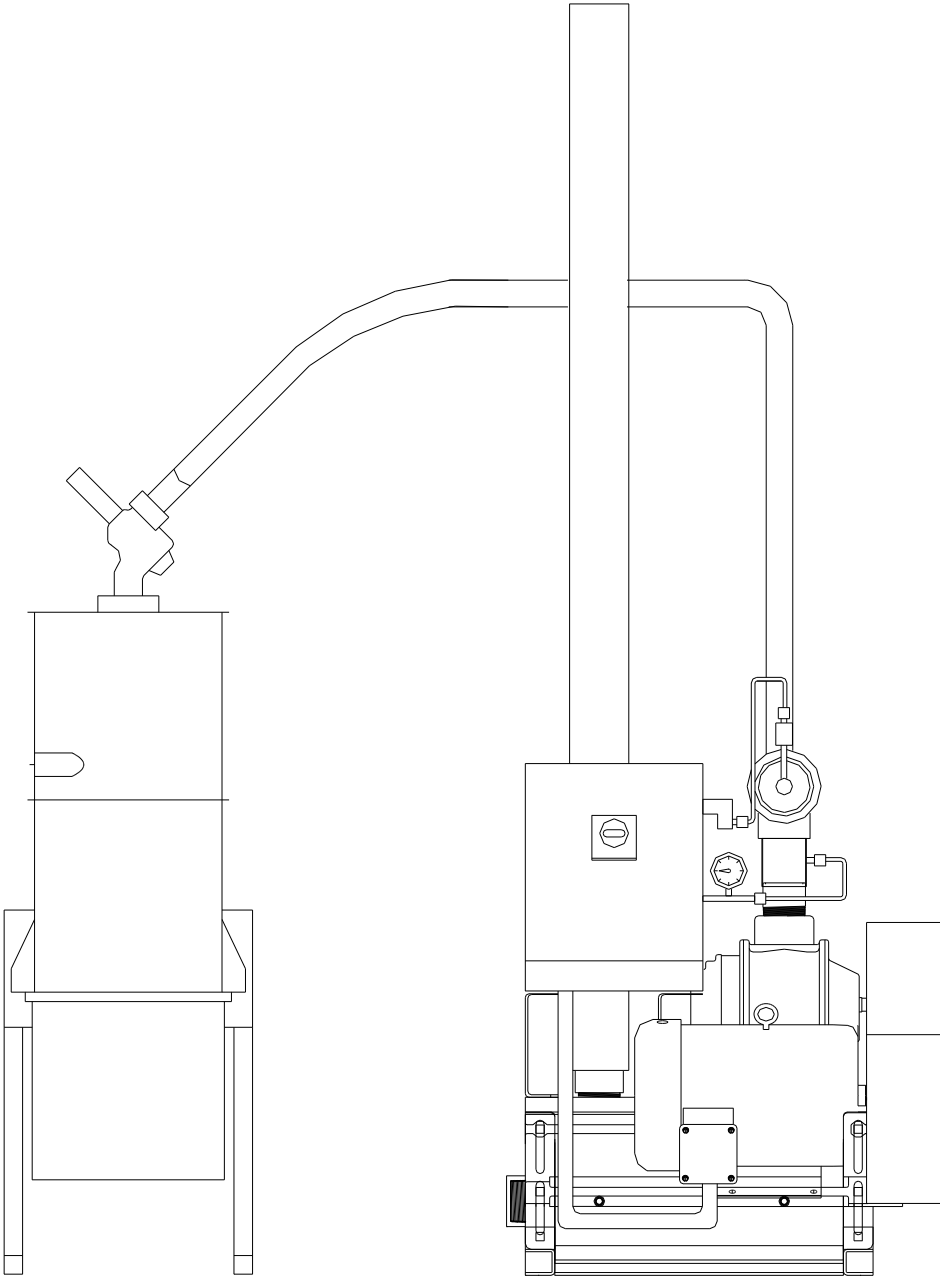

Note: Make sure you have all tubing supported at ten (10) foot (3 meter) intervals.

Installing Vacuum Receivers and Inventory/Vacuum Receivers

Vacuum uses one of three mounting systems: flange, suspension, or silo mounting. Vacuum receivers and inventory vacuum receivers use flange mountings only.

3-3 Compressed Air Connections

Making Pump Compressed Air Connections

Connect the vacuum pump to a minimum of 60 psi to 80 psi (414 kPa to 552 kPa) source of clean, dry, lightly lubricated compressed air. Make the 1/8" NPT (3 mm) connection at the solenoid valve on the pump package.

Your compressed air supply piping should include:

- A shutoff valve for ON/OFF control.
- A pressure regulator with gauge.
- An air filter/lubricator.

3-4 Electrical Connections

Refer to local electrical codes, the schematic, and connection diagrams supplied with this unit and the serial tag for wiring considerations. Run all wiring in conduit if codes require it. Label all wiring to make any future troubleshooting easier. Make all electrical connections *tight*.

Making Pump Power Drop Wiring Connections

WARNING!



Be safety conscious! High or low voltage can cause serious or fatal injury. Installation must be performed by qualified personnel only!! Always disconnect power source before attempting installation or repair.

Pump packages are connected to a three-phase power supply. Bring properly sized power leads in conduit to the contacts in the junction box of each pump package in the system. Complete the pump wiring connections by performing the following:

- Install a properly-sized fused disconnect switch with lockout on the main lines to each vacuum pump package. This is recommended even for pumps with optional fused disconnects.
- Check the serial tag for voltage and amperage requirements. On 60 Hz units, voltage supplied to the unit must be within plus or minus ten percent ($\pm 10\%$) of the serial tag value; on 50 Hz units, within plus or minus five percent ($\pm 5\%$) of the serial tag value. Phase imbalance must be less than 2% in accordance with NEMA MG1-14.32.
- Ground the unit for operator safety and equipment protection.

Making Control Panel Power Drop Wiring Connections

Plug the controllers' power cord into a properly grounded, 3-slot, 115/1/60 VAC or 230/1/60 VAC receptacle as specified on the control panel serial tag and the enclosed controller Operation and Instruction manual. The control enclosure draws less than 5 amps during normal operation at 115/1/60 VAC.

Caution! *The manufacturer recommends that you protect PLC memory by providing the control panel with a dedicated circuit, a true earth ground, and a spike/surge protector.*

Connecting the Control Panel to the Pump Package

Note: Consult the specific schematics and Operation & Instruction manual supplied with your controller for your specific application.

- Wire the pump package motor starter coil (M) to the terminal provided in the conveying system control panel enclosure.
- Wire the pump package vacuum relief valve solenoid (SOL A) to the terminal provided in the conveying system control panel enclosure.
- Wire the pump package high vacuum switch (VS) to the terminal located in the conveying system control panel enclosure.

Note: Make sure that the pump motor starter, the vacuum relief valve solenoid, and the blowback solenoid (if supplied) are the same voltage (24 VDC) as the conveying system control panel control voltage. Consult the control panel serial tag and the pump package serial tag.

Note: Wire size depends on control voltage, distance, number of vacuum hoppers, and the number of wires in each raceway. Consult a qualified electrician.

3-5 Initial Start-up

Making Startup Checks

Before operating the pumps or any other part of the conveying system, check these details:

1. All components in the system must be installed securely and prepared for operation. Refer to the instructions supplied with auxiliary equipment for specific checks.
2. Couplers, fittings, attachments, and flexible lines must be attached securely and be vacuum-tight.
3. Electrical and compressed air connections to the pump package, vacuum hoppers, and filter chambers must be complete, safe, and conform to code.
4. The pump package blower gearbox must be filled with oil as specified in the manufacturer's instructions included in the customer information package.

Caution! ***Do not overfill the blower gearbox with oil, too much oil damages the blower.***

5. If not done already, remove the plastic plug from the silencer air outlet.

WARNING! ***Keep hands away from the open air inlet to avoid injury!***



6. Do not allow any loose parts, tools, or foreign materials in or near the unit and other system components.
7. Check for proper motor rotation, as indicated by an arrow on the pump package motor. Bump-start the pump package with the compressed air disconnected just long enough to verify proper rotation direction.

Note: ***To change motor rotation:***

- ***Disconnect power at the external disconnect.***
 - ***Switch any two incoming power leads on the main power supply.***
8. Make sure that filter chamber housings have no leaks; check stretcher clamps for tightness.

Chapter 4: Operation

4-1 Start-up

1. Check the pump for any obstructions that may cause damage.
2. Turn on the compressed air supply to the atmospheric valve on the pump junction box.
3. Switch the disconnect on the pump junction box to the ON position.
4. The pump is now on line and ready for operation.

4-2 Operation Procedures

When you activate the controller, the system energizes and initiates the conveying cycle. The following components energize:

- The vacuum pump motor starter.
- The vacuum pump vent valve.
- The sequencing valve above the first on-line vacuum receiver that requires material.

The vacuum pump draws vacuum to that receiver. When the receiver is full or the time interval elapses, the controller then signals the atmospheric valve above the next on-line receiver requiring material to energize, allowing material to convey to that receiver. The conveying sequence continues to the last on-line vacuum receiver requiring material.

When the time interval for the last receiver elapses or the receiver is full, a new conveying cycle begins at the first on-line vacuum receiver requiring material.

Note: *The sequence of events listed above is a generalized description of what occurs when a controller is activated. Consult your specific controller manual for an accurate depiction of these events.*

Vacuum Switch (VS) Operation

A high vacuum switch is mounted inside a pump package junction box. It is preset to close at 14" Hg (475 millibars) and is not adjustable. The vacuum switch protects the pump package from motor damage caused by high amperage draw and strain on the blower.

Pumps typically draw a vacuum of less than 5" Hg (170 millibars) only when air is pulled into the system and 8" to 12" Hg (271 to 339 millibars) while conveying.

If system vacuum should reach 14" Hg (475 millibars), the high vacuum switch closes. The pump package tries to clear the line for three seconds, then moves to the next on-line vacuum receiver. The normal conveying cycle continues. If high vacuum keeps occurring, the pump continues with attempts to clear the line.

Refer to your specific controller manual for additional operation information.

High Vacuum Relief Regulator Operation

A factory-set pressure regulator is installed on the pump package vent valve as a mechanical back-up safety feature. It protects the pump motor from damage during high vacuum conditions if an undetected failure of the vacuum switch should occur. The regulator is set to limit system vacuum to 15” Hg (475 millibars) by allowing the vent valve plunger to shift and vent the pump.

Note: Do not adjust the pressure regulator. Adjusting the pressure regulator voids your warranty.

4-3 Shut-down

To deactivate the conveying system:

1. Turn the disconnect switch at each pump or component to OFF. This will take each pump or component offline.
2. Turn off the compressed air supply to the system.

Note: Consult your specific controller operation and instruction manual for specific shut-down information for your conveying system.

Chapter 5: Maintenance

5-1 Preventative Maintenance Schedule

The checklist below contains a list of items which should be inspected and/or replaced to keep the mechanical components of your conveying system operating at peak efficiency. Perform each inspection at the regular intervals listed below.

System model #						Serial #							
Every week	Date/By	Date/By	Date/By	Date/By	Date/By	Date/By	Date/By	Date/By	Date/By	Date/By	Date/By	Date/By	Date/By
Inspect all filters for wear, replace/clean if dirty or worn.													
Check to make sure that all hose connections are air tight.													

Every month	Jan	Feb	Mar	Apr	May	Jun	Jul	Aug	Sep	Oct	Nov	Dec
Lock out electrical power and inspect electrical wiring for integrity.												
Check demand sensor.												
Inspect gaskets at hoppers.												
Inspect belt(s).												
Oil & grease (lubricate) components												

- Photocopy this page for your maintenance records -

5-2 Preventative Maintenance

Maintaining Pump Packages

Pump packages need periodic maintenance to provide long dependable service. Check these elements regularly:

- Maintain a proper oil level in the blower gearbox. The manufacturer's brochure (packed with the pump package) recommends oils, and lists instructions for checking the oil level.
- Pack blower bearings with high temperature ball bearing grease and change the oil to the manufacturer's recommendations.
- V-belts are sized for maximum life with the pump package blower/motor combination. Inspect periodically for proper tension, and replace when worn.

Note: *V-belts stretch when new. Check belt tension after you have run them in. At proper belt tension, the belt should deflect downward 1/64" for every one inch span (1 mm every 6.4 cm) from sheave to sheave.*

- Keep the pump package area clear of any debris that could be drawn through the vent valve and into the blower while the pump package is idling.
- Torque the motor and blower sheave bolts to 72 ft.-lbs. (98 N•m).
- Check the moisture traps in the compressed air lines. Drain as needed.
- Check the compressed air lubricator(s) for flow rate and level. **Use only 1 or 2 drops of oil per day** when lubricating. Adjust and fill as necessary.
- Inspect the silencer periodically for contamination. Silencer fouling indicates poor filter maintenance at the vacuum hopper or filter chamber. Fines may also be drawn into the silencer through the pump package vent valve during the dump cycle from poor housekeeping near the pump package.

Caution! *Make sure you replace a contaminated silencer immediately to avoid blower damage and possible fire hazard.*

- Standard pump package TEFC motors do *not* require lubrication or oiling. Optional motors may have different requirements. Refer to the motor manufacturer's specification sheet in your Customer Information Packet.
- Keep the control panel and pump package junction boxes securely closed to prevent component contamination.
- Inspect air cylinders and plungers for proper operation.
- Verify that all safety components/circuits are in full operational condition.

Chapter 6: Troubleshooting

6-1 Introduction

The utmost in safety precautions should be observed at all times when working on or around the machine and the electrical components. All normal trouble-shooting must be accomplished with the power off, line fuses removed, and with the machine tagged as out of service.

The use of good quality test equipment cannot be over-emphasized when troubleshooting is indicated. Use a good ammeter that can measure at least twice the AC and DC current that can be encountered for the machine. Be sure that the voltmeter has at least minimum impedance of 5,000 OHMS-per-volt on AC and 20,000 OHMS-per-volt on DC scales. Popular combination meters, VOM and VTVM can be selected to provide the necessary functions.

Before making haphazard substitutions and repairs when defective electrical components are malfunctioning, we recommend that you check the associated circuitry and assemblies for other defective devices. It is common to replace the obviously damaged component without actually locating the real cause of the trouble. Such hasty substitutions will only destroy the new component. Refer to wiring diagrams and schematics.

Locating mechanical problems, should they occur, is relatively straightforward. When necessary, refer to the parts catalog section.

Note: *Refer to specific control panel operation and instruction manual for additional details and Troubleshooting information.*

Problem	Possible Cause	Possible Remedy
The pump doesn't run even though it is on line. (Refer to enclosed Control Panel Manual)	The motor overload tripped.	Reset the overload and check the motor for the proper amp draw as listed on the serial tag.
	No demand signal/stations offline.	Check control panel.
	Control panel problem.	Verify wire connections. Inspect output cards.
	Main fuse in power drop or optional fused disconnect has blown.	Replace the fuse. Check for 3-phase voltage.
	Motor contactor is faulty.	Repair or replace as required.
A vacuum receiver bypasses in the Loading cycle. (Refer to enclosed Control Panel Manual)	The bin below the vacuum receiver is full if the amber receiver indicator light is off.	Normal operation. When hopper level drops, material begins conveying to it.
	The receiver is off line.	Put it on line via menus.
	Static convey time was set to zero.	Put in a reasonable convey time via menus.
	Field installed station by-pass switch is simulating a bin-full condition.	Normal operation. Throw field-installed switch to put hopper back in the loading sequence.

Problem	Possible Cause	Possible Remedy
A vacuum receiver bypasses in the Loading cycle. Cont'd. (Refer to enclosed Control Panel Manual)	The field-installed station bypass switch is bad or miswired.	Repair, replace, or rewire.
	Insufficient compressed air to shift valves.	Supply 80 psi (552 kPa) compressed air to all compressed air- operated valves.
	The Bin-Full switch sensor fails to close.	Standard switch is normally open, held closed by the magnet. Check for the presence of the magnet and for proper switch operation.
	The Receiver-Full proximity sensor is fouled, creating a false reading (Volume Fill systems only).	Wipe off the proximity sensor. Re-adjust if needed.
	The Receiver-Full proximity sensor has failed closed (Volume Fill systems only).	Replace.
Pressure is present at the vacuum inlet.	Improper pump rotation.	Switch any two wires at the incoming power.
	Blowback solenoid failed open.	Check filter chamber or pump.
No-Convey alarm. (Part of vacuum control panel. Refer to enclosed Control Panel Manual.)	Material supply empty.	Refill the supply.
	Material supply bridging.	Agitate material supply.
	Pick up device not in supply.	Re-insert the probe.
	Flapper stuck in open position.	Clear flapper of obstructions.
	Power to vacuum pump off.	Inspect power.
	Bad level sensor.	Replace level sensor.
	Plugged material line.	Find and remove obstruction.
	Vacuum line leak.	Find and repair leak.
Sequence-T valve problem (where used).	Check for signal, sufficient compressed air, proper wiring and operation.	
High-Vacuum alarm.	Material or vacuum line plugged.	Find and remove the obstruction, such as a coupling gasket.
	Filter chamber filter dirty.	Clean filter.
	Vacuum hopper filter dirty.	Clean filter.
	Bad atmospheric/sequence-T valve.	Check for signal, sufficient compressed air, proper wiring and operation.
	Vent valve on pump package not operating correctly.	Check for signal, sufficient compressed air, proper wiring and operation.
	Improper piping.	Locate and correct.
	Convey time set too long.	Reduce convey time.
Collapsing hoses.	Inspect hoses.	

Problem	Possible Cause	Possible Remedy
High-Vacuum alarm. Cont'd.	Faulty vacuum switch.	Test – ON – replace switch.
	Take off compartment closed.	Adjust take-off box.
Vacuum receivers are being overfilled. (Refer to enclosed Control Panel Manual)	Conveying times are too long (Time Fill only).	Observe and time the hopper(s) when loading. Note the time needed to fill a hopper. Set the conveying time to a few seconds less.
	Special convey enabled.	
	Maximum conveying times are too long (Volume Fill only) and the Receiver Full proximity switch(es) are not being recognized by the PLC.	Check proximity sensors for proper operation and proper wiring to PLC. Repair. Re-set the conveying times to reasonable times. Re-adjust if needed.
Vacuum receivers are being underfilled.	Poor take-off adjustment.	Observe and time the hopper(s) when loading. Note the time needed to fill a hopper. Set the conveying time to a few seconds more.
	Conveying times are too short (Time Fill only). (See control panel's O & I.)	
	Vacuum line leak.	Find and repair leak.
	No material to convey.	Make sure pickup probe is buried in material source.
	Vacuum filter is plugged.	Clean and/or replace filter.
Filter chamber filter cartridge is becoming obstructed too frequently by fines and dust.	Dump Delay time set to zero, or insufficient dump delay time.	Set dump delay time to the time it takes the largest vacuum hopper in the system to dump.
	Dusty material.	Consult sales representative.
	Dusty material — Optional compressed air filter cleaning may be needed on filter chamber.	Consult sales representative.
Pumps and receivers are on-line, but the pumps are not conveying material. (Refer to enclosed Control Panel Manual for specific instructions.)	No material demand at receivers if none of the amber lights on the optional light board are lit.	Normal operation. Pump packages shut off thirty (30) seconds after no demand is detected for the time programmed.
	The on-line receivers are not assigned to the pumps that are on-line.	Reconfigure the control panel, assigning the pumps to the desired hopper.

Problem	Possible Cause	Possible Remedy
<p>Optional audible/visual alarm installed on a Volume Fill system continues to signal after the Press-To-Silence button is pressed.</p> <p>(Refer to enclosed Control Panel Manual for specific instructions.)</p>	<p>The alarm is triggered every time an alarm message displays.</p>	<p>In cases where numerous alarm conditions occur, alarm messages build up in the display buffer. Each time one is released from the buffer, the alarm sounds.</p> <p>The operator may:</p> <ul style="list-style-type: none"> • Press the silence button after each message • Disable the alarm using the control panel keypad • Cancel No-Convey alarm(s) ①. <p>Correct the problem causing the alarm. Alarm will not trigger again until another high vacuum condition occurs. If multiple alarm messages are in the buffer, the button may need to be pressed a few times.</p>
<p>Optional audible alarm is not functioning.</p>	<p>The alarm package is wired incorrectly.</p>	<p>Correct wiring. Consult wiring diagram.</p>
<p>(Refer to enclosed Control Panel Manual for specific instructions.)</p>	<p>Alarm package component failure.</p>	<p>Troubleshoot and repair/replace problem.</p>

① To cancel No Convey alarm(s):

- Take the problem receiver(s) off line with field-installed station bypass switches.
- Take the problem receiver(s) off line with the control panel.
- Remove the material demand by filling the bin below the vacuum receiver.

Problem	Possible Cause	Possible Remedy
<p>Vacuum conveying rate is declining due to a vacuum loss in the system.</p>	<p>Pump package blower problem. Use a cfm/cfh monitoring device to ensure that blower cfm/cfh is to the manufacturer's specifications.</p> <p>Consult Service Engineer if problem persists.</p>	<ul style="list-style-type: none"> • Blower is dead-headed. Check for obstruction. • Vent valve is not operating. Check for proper signal, voltage, and 80 to 90 psi (552 to 621 kPa) compressed air. • Worn seals in blower. Rebuild/replace blower. • Worn bearings in blower. Rebuild or replace. • Loose drive belt(s). Tighten or replace if worn.
		<p>Follow the vacuum path from the blower through the filter, piping, valves and material receivers to isolate where the loss occurs.</p>
		<p>Filter chamber problem. The vacuum at the filter chamber should be the same as the blower generates. If the vacuum at the filter chamber is adequate, the problem is down line.</p>
		<ul style="list-style-type: none"> • Dirty filter. Clean or replace filter. • Loose clamps, gaskets or couplers. Tighten or replace. • Filter chamber discharge flapper not sealing under vacuum. Check for proper operation; clean or repair as needed. • Check for faulty compressed air blowback solenoid. Check for voltage signal during cleaning cycle, proper solenoid operation, incorrect wiring, proper compressed air connection, and for worn plunger in valve.

Problem	Possible Cause	Possible Remedy
<p>Vacuum conveying rate is declining due to a vacuum loss in the system.</p> <p>(Cont'd.)</p>	<p>Pump package blower problem. Use a cfm/cfh monitoring device to ensure that blower cfm/cfh is to the manufacturer's specifications.</p> <p>Consult Service Engineer if problem persists.</p> <p>(Cont'd.)</p>	<p>Vacuum line problem. Disconnect the vacuum line at the first vacuum hopper and block it off. The vacuum here should equal the vacuum at the blower. Allow a few seconds for vacuum to build. If the vacuum here is low, disconnect the piping halfway to the first vacuum hopper and check the vacuum there. If proper vacuum exists, the problem is upstream. If not, work backward to isolate the vacuum loss.</p> <ul style="list-style-type: none"> • Tighten loose pipe couplers; replace worn gaskets as needed. • Replace any damaged piping found.
	<p>Leaks in vacuum lines between valves.</p>	<p>Check for leaks as described in previous steps.</p>
	<p>Vacuum leak(s) in vacuum hoppers.</p>	<ul style="list-style-type: none"> • Replace or re-install worn or misaligned gaskets. • Hopper discharge flapper not sealing under vacuum. <ol style="list-style-type: none"> 1) Replace worn or missing gasket. 2) Clean fouled flapper. 3) Check counterweight for proper operation. Repair or adjust as needed. • Internal check valves missing or damaged. On single line Y systems, internal check valves must be installed in the vacuum hoppers to seal all hoppers not being conveyed to. If the check valves are present and undamaged, they may be pushed too far onto the tube stub to permit a proper seal. Also, if the hopper is over-filled, the check valve may not seal properly.
	<p>Vacuum leaks in material lines.</p>	<p>Check for leaks as described in previous steps.</p>

Problem	Possible Cause	Possible Remedy
Vacuum conveying rate is declining due to a vacuum loss in the system. (Cont'd.)	Material take-offs not properly adjusted.	Too much air and not enough material or too much material and not enough air. Close takeoff compartment material inlet, slowly open until you hear material surging and slugging. Close material inlet until surging disappears. On most systems, a proper adjustment generates a 6" to 10" Hg (203 to 339 millibars) vacuum.
	The blower is dead-headed.	Check the blower inlet for obstruction.
Material is sucked from the filter chamber and through the blower.	Filters in the filter chamber are dislodged, worn, or not seated properly on the gasket.	Replace or repair immediately. If the exhaust silencer has material in it, replace it to prevent fire hazard.
	The material conveyed is not what the system was designed for. Very dusty materials have different conveying needs.	Consult manufacturer for advice on hardware requirements.

Other service problems or questions can be answered by contacting the Service Department.

Chapter 7: Appendix

7-1 Warranty

The manufacturer warrants all equipment manufactured by it to be free from defects in workmanship and material when used under recommended conditions. The company's obligation is limited to repair or replace FOB the factory any parts that are returned prepaid within one year of equipment shipment to the original purchaser, and which, in the company's opinion, are defective. Any replacement part assumes the unused portion of this warranty.

This parts warranty does not cover any labor charges for replacement of parts, adjustment repairs, or any other work. This warranty does not apply to any equipment which, in the company's opinion, has been subjected to misuse, negligence, or operation in excess of recommended limits, including freezing or which has been repaired or altered without the company's express authorization. If the serial number has been defaced or removed from the component, the warranty on that component is void. Defective parts become the property of the warrantor and are to be returned.

The company is not liable for any incidental, consequential, or special damages or expenses. The company's obligation for parts not furnished as components of its manufactured equipment is limited to the warranty of the manufacturers of said parts.

Any sales, use, excise, or other tax incident to the replacement of parts under this warranty is the responsibility of the purchaser.

The company neither assumes nor authorizes any other persons to assume for it any liability in connection with the sale of its equipment not expressed in this warranty.

Many types of the manufacturer's equipment carry an additional one-year service policy. Consult your sales representative for specific details.

7-2 Technical Specifications

Annex B Information

The following design information is provided for your reference:

1. No modifications are allowed to this equipment that could alter the CE compliance
2. Ambient temperature: 40 degrees Celsius – Maximum (104 degrees Fahrenheit)
3. Humidity range: 50% relative humidity
4. Altitude: Sea level
5. Environment: Clean, dust-free and non-explosive
6. Radiation: None
7. Vibration: Minimal, i.e. machine mounting
8. Allowable voltage fluctuation: +/- 10%
9. Allowable frequency fluctuation: Continuous +/- 1%
Intermittent +/- 2%
10. Nominal supply voltage: 460/3/60 (Verify on serial number tag)
11. Earth ground type: TN (system has one point directly earthed through a protective conductor)
12. Power supply should include a ground connection.
13. Over-current protection is supplied in the conveying system, but additional protection should be supplied by the user.
14. The door-mounted disconnect serves as the electrical disconnect device.
15. Conveying system is not equipped with local lighting.
16. Functional identification
17. Conveying system is equipped with a CE mark
18. Conveying system is supplied with an operating manual in the language of the destination country.
19. Cable support may be required for power cord, depending on final installation.
20. No one is required to be in the interior of the electrical enclosure during the normal operation of the unit. Only skilled electricians should be inside the enclosure for maintenance.
21. Doors can be opened with a screwdriver, but no keys are required.
22. Two-hand control is not required or provided.
23. All components should be moved around and set in a place with a lift truck or equivalent.
24. There are no frequent repetitive cycles that require manual control□ repetitive functions are automatic while the conveying system is operating.
25. An inspection report detailing the functional test is included with the conveying system.
26. The machine is not equipped with cableless controls.
27. Color-coded (harmonized) power cord is sufficient for proper installation.

7-3 Spare Parts List

Figure 14: Positive Displacement Vacuum Pump Spare Parts List

HORSEPOWER	QTY	PART NO	DESCRIPTION
5	1	A0571182	BLO,ROOTS,33RAI-J,WHISPAIR,DSL
5	1	A0538259	SHV,2-3V4.5,P1,BSHG,BLOWER
5	1	A0538247	SHV,2-3V,6.9,Q1,BSHG,MOTOR
5	1	W00000145	ORNG,BUNA70,1.984ID X 0.139CS
5	1	W00013524	PLGR,2.38OD,EPT,BLK,3/8-16,CS
5	1	W00017811	GSKT,VELOMOID,2-2.25SEQ VLV
5	1	A0571127	BSHG,ROOTS,1610X3/4-KW,RSP1113,BLO
5	1	A0571128	BSHG,ROOTS,1610X1-1/8-KW,RSP1011,MOT
5	1	W00052176	MTR,5HP,184T,208/230/460/60
5	1	W00532583	MTR,5HP,184T,380/3/50
5	1	A0547948	MTR,5HP,184T,415/3/50
5	1	W00052800	MTR,5HP,184T,575/3/60
10	1	A0571183	BLO,ROOTS,45RAI-J,WHISPAIR,DSL
10	1	A0538248	SHV,2-3V,4.7,H,BSHG,BLOWER
10	1	A0534550	SHV,2-3V,6.0,P1,BSHG,MOTOR
10	1	W00017812	GASKET,3",AV,VALVE
10	1	W00001958	PLGR,2.86OD,EPT,BLK,3/8-16,CS
10	1	W00001045	ORNG,BUNA70,2.484ID X 0.139CS
10	1	A0571129	BSHG,ROOTS,1610X7/8-KW,RSP1005,BLO
10	1	A0571130	BSHG,ROOTS,1610X1-3/8-KW,RSP1003,MOT
10	1	W00016464	MTR,10HP,215T,208/230/460/3/60
10	1	W00532585	MTR,10HP,215T,380/3/50
10	1	A0547950	MTR,10HP,215T,415/3/50
10	1	W00052802	MTR,10HP,215T,575/3/60
15	1	A0571183	BLO,ROOTS,45RAI-J,WHISPAIR,DSL
15	1	A0534550	SHV,2-3V,6.0,P1,BSHG,BLOWER
15	1	A0571132	SHV,2-3V,10.6,P1,BSHG,MOTOR
15	1	W00001738	ORNG,BUNA70,2.984ID X 0.139CS
15	1	W00001958	PLGR,2.86OD,EPT,BLK,3/8-16,CS
15	1	W00017812	GSKT,VELOMOID,2.5-3SQVLV
15	1	A0571129	BSHG,ROOTS,1610X7/8-KW,RSP1005,BLO
15	1	A0571131	BSHG,ROOTS,1610X1-5/8-KW,RSP1008,MOT
15	1	W00016466	MTR,15HP,254T,208/230/460/3/60
15	1	W00532586	MTR,15HP,254T,380/3/50
15	1	A0547954	MTR,15HP,254T,415/3/50
15	1	W00052803	MTR,15HP,254T,575/3/60

Figure 14: Positive Displacement Vacuum Pump Spare Parts List Cont'd.

HORSEPOWER	QTY	PART NO	DESCRIPTION
5/10/15	1	A0069307	TBG,PE,0.250OD X 0.040W,NAT
5/10/15	1	A0547079	GAUG,VAC,2.5D,0-30",SS,GF,1/4"
5/10/15	1	35085K	STRAIGHT,MALE,1/8"NPT X 1/4"OD
5/10/15	1	35086K	ELBOW,1/8"NPT,MALE X 1/4" OD
5/10/15	1	A0543268	FTG,BR,BU,0.25NPT X 1/8 NPT
5/10/15	1	A0543269	FTG,BR,TE,0.25NPT
5/10/15	1	A0532231	NIP,BR,0.25NPT X 0.88LG,CL
5/10/15	1	W00013961	REG,AIR,MINT,1.27E+08,HPR,LDR
5/10/15	1	W00017552	CYL,KIT,SEAL,AIR,1.5-7HP
5/10/15	1	W00017688	CYL,AIR,S1311,1.5-15HP,2,HOLE
5/10/15	1	A0571252	SOLV,3WAY,24VDC,1/8NPT
5/10/15	1	A0015492	NIP,CS,0.13NPT X 3.00LG
5/10/15	2	W00090871	OIL,MTR,40W,FOR VAC UNIT BLWRS
5/10/15	2	W00011500	BELT,V,3VX,450
5/10/15	1	A0562421	CONN,BOX,LT,NYL,STR,0.500
5/10/15	1	A0562419	CONN,BOX,LT,NYL,EL,90,0.500
5/10/15	3 FT	A0562430	CND,FLEX,NYL,0.500

Figure 15: Centrifugal Vacuum Pump Spare Parts List

HORSEPOWER	QTY	PART NO	DESCRIPTION
3.5/6.5	1	W00000145	ORNG,BUNA70,1.984ID X 0.139CS
3.5/6.5	1	W00013524	PLGR,2.38OD,EPT,BLK,3/8-16,CS
3.5/6.5	1	W00017811	GSKT,VELOMOID,2-2.25SEQ VLV
3.5/6.5/11	1	A0069307	TBG,PE,0.250OD X 0.040W,NAT
3.5/6.5/11	1	A0547079	GAUG,VAC,2.5D,0-30",SS,GF,1/4"
3.5/6.5/11	1	35086K	ELBOW,1/8"NPT,MALE X 1/4" OD
3.5/6.5/11	1	W00013961	REG,AIR,MINT,1.27E+08,HPR,LDR
3.5/6.5/11	1	W00017552	CYL,KIT,SEAL,AIR,1.5-7HP
3.5/6.5/11	1	W00017688	CYL,AIR,S1311,1.5-15HP,2,HOLE
3.5/6.5/11	1	A0543268	FTG,BR,BU,0.25NPT X 1/8 NPT
3.5/6.5/11	1	A0543269	FTG,BR,TE,0.25NPT
3.5/6.5/11	1	A0532231	NIP,BR,0.25NPT X 0.88LG,CL
3.5/6.5/11	1	35085K	STRAIGHT,MALE,1/8"NPT X 1/4"OD
3.5/6.5/11	1	A0571252	SOLV,3WAY,24VDC,1/8NPT
3.5/6.5/11	1	W00000334	CLAMP,HOSE,FOR P/N 3816,2.5"
3.5/6.5/11	1	A0015492	NIP,CS,0.13NPT X 3.00LG
3.5/6.5/11	1	A0547079	GAUG,VAC,2.5D,0-30",SS,GF,1/4"
3.5/6.5/11	1	A0562421	CONN,BOX,LT,NYL,STR,0.500
3.5/6.5/11	1	A0562419	CONN,BOX,LT,NYL,EL,90,0.500
3.5/6.5/11	3FT	A0562430	CND,FLEX,NYL,0.500
3.5	1	A0570037	BLO,3.5,HP,SPC,PUMP,208-460 V
3.5	1	A0570030	BLO,3.5,HP,SPC,PUMP,575 V
6.5	1	A0570038	BLO,5 HP,SPC,PUMP,208-460 V
6.5	1	A0570033	BLO,5 HP,SPC,PUMP,575 V
11	1	A0570039	BLO,11.5 HP,SPC,PUMP,208-460 V
11	1	A0570040	BLO,11.5 HP,SPC,PUMP,575 V
11	1	W00001045	ORNG,BUNA70,2.484ID X 0.139CS
11	1	W00001958	PLGR,2.86OD,EPT,BLK,3/8-16,CS
11	1	W00017812	GSKT,VELOMOID,2.5-3SQVLV

7-4 Identification (Serial Number) Tag

(Located on back of Component of Conveying System)

Company Logo	
	XXX Series Vacuum Pump
	Model Number XXX-5
Max Conveying Capacity HR	
460V	Serial Number 060701R
1_	Date of Manufacture 06/2003
4.5A	
Over-current Protection Device (s) 4.5A Total	
Frequency 50/60Hz	
Compressed air supply 120 PSI	
Electrical Diagrams & Pneumatic Diagram	<input type="text"/>
Street Address	City, State Zip Code
Telephone Number	

7-5 Technical Assistance

Parts Department

Call toll-free 7am–5pm CST [800] 423-3183 or call [630] 595-1060, Fax [630] 475-7005

The ACS Customer Service Group will provide your company with genuine OEM quality parts manufactured to engineering design specifications, which will maximize your equipment's performance and efficiency. To assist in expediting your phone or fax order, please have the model and serial number of your unit when you contact us. A customer replacement parts list is included in this manual for your convenience. ACS welcomes inquiries on all your parts needs and is dedicated to providing excellent customer service.

Service Department

Call toll-free 8am–5pm CST [800] 233-4819 or call [630] 595-1060

Emergencies after 5pm CST, call [847] 439-5655

We have a qualified service department ready to help. Service contracts are available for most products.

Sales Department

Call [630] 595-1060 Monday–Friday, 8am–5pm CST

Our products are sold by a world-wide network of independent sales representatives. Contact our Sales Department for the name of the sales representative nearest you.

Contract Department

Call [630] 595-1060 Monday–Friday, 8am–5pm CST

Let us install your system. The Contract Department offers any or all of these services: project planning; system packages including drawings; equipment, labor, and construction materials; and union or non-union installations.

