

Small
Powerful
Agile
Intuitive
Simply Incredible

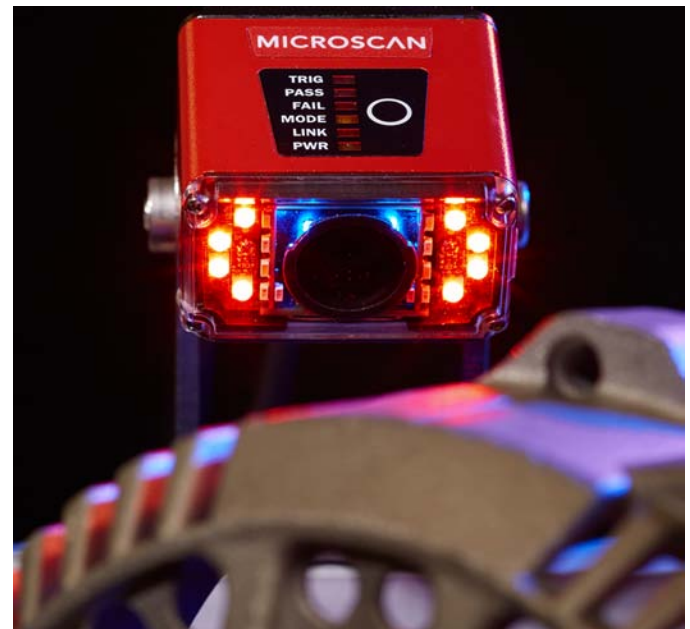

MICRO HAWK

Barcode Readers



MICROSCAN®

1982

Company Founded

Products Sold

1 Million

100+

Technology Patents

Worldwide Offices

22

300+

Partners Worldwide

Microscan: Barcode Reading At Its Best

Microscan provides today's industrial professionals with the most user-friendly barcode reading platforms, thoughtfully engineered to meet tomorrow's challenges. Our barcode readers enable faster, more accessible, and broader data communication in a wide range of applications.

As the inventor of the first laser diode barcode scanner, our company was founded on technology innovation and continues to be a technology leader today. Microscan holds one of the world's most extensive patent portfolios for barcode reading technology, including laser scanning, imaging technologies, hardware and software.

Microscan is in a continuous process of research and development to provide cutting-edge technology and complete solutions for auto ID barcode applications. Today, we provide fast, reliable reading solutions for **all symbologies and OCR**. Our products read any linear barcode or 2D symbol printed or marked by any means, with a versatility and ease of use unprecedented in the industry.

Microscan products are sold and supported through a global network of partners and systems integrators who specialize in automation solutions. The network includes more than 300 experienced automation integrators and value-added resellers in over 30 industrialized countries for highly-specialized local support.



MicroHAWK: Simply Incredible

Mini is now micro. Ease of use is now intuitive. Performance is now available in any configuration. Barcode reading is now simply incredible. Meet MicroHAWK, the next generation of industrial barcode readers. Built on the highest-performance imaging engine in its class, MicroHAWK barcode readers offer an array of modular hardware options to take on any decoding task in three micro-form-factors. No software to install, no compatibility obstacles, no experience needed. Just plug in and open a browser.



- World's smallest industrial barcode imagers
- Read any code on any surface
- User-friendly barcode reading platform
- Customizable hardware options

Features	ID-20	ID-30	ID-40
1D Omnidirectional Barcodes	●	●	●
1D/2D Barcodes	●	●	●
Damaged Barcodes	●	●	●
Direct Part Mark (DPM)		●	●
Enclosure	IP40	IP54	IP65/67
Ethernet TCP/IP, EtherNet/IP™			●
Ethernet Over USB	●	●	
Serial (RS-232)		●	●
USB 2.0 High Speed	●	●	
Outer Illumination		●	●
Standard or High-Density	●	●	●
Color Sensor	●	●	●
High-Speed		●	●
WebLink User Interface	●	●	●

MicroHAWK Engine



- Provides the full range of capabilities of all the readers in the MicroHAWK family
- Smallest fully-integrated imaging engine available
- Lightweight, feature-rich and ready for easy integration into a wide range of instruments and machines

Microscan's WebLink User Interface



- Compatible with any USB or Ethernet MicroHAWK reader
- Set up, test and control your reader from the browser of your choice
- World's first web-based barcode reader interface
- No installed software required

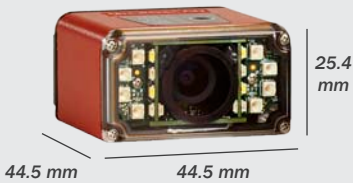
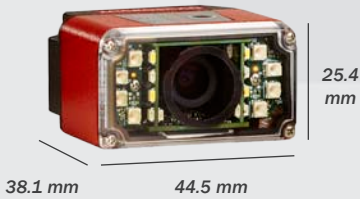

Incredibly Small

Designed specifically for integration into the tightest spaces, MicroHAWK barcode readers are the most compact, lightweight, and durable devices for tough industrial environments. The ID-40 is the world's smallest industrial IP65/67-rated barcode reader available. MicroHAWK readers include features such as integrated lighting and targeting LEDs, flexible cabling, and wide-angle optics to enable easy decoding of both long 1D and small 2D barcodes at close range.



ID-40
SMALLEST
 Industrial IP65/67-Rated
 Barcode Reader Ever

MicroHAWK Readers Can Decode:

- Directly-printed barcodes on labels
- Directly-marked Data Matrix including dot peen, laser etch and ink jet
- Low contrast, scratched or poorly-printed barcodes
- Mix of 1D and 2D barcodes on a single part or package

Incredibly Powerful

When the ability to read challenging barcodes and marks is critical to success, count on MicroHAWK. Damaged and incomplete symbols are processed by X-Mode to render damaged symbols readable despite unpredictable print issues, scratches, or obstructions. For reliable decoding at the speed you need, MicroHAWK readers come standard with speeds up to 10 frames per second (FPS). High-Speed options are also available with speeds up to 60 FPS.

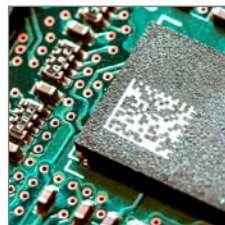
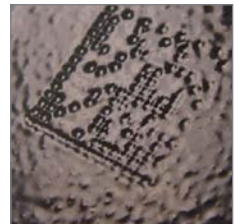

Incredibly Agile

MicroHAWK offers nearly endless configurations in three micro-form-factor barcode readers. Sensor, speed, lighting, and decoding power can be selected in any combination and packaged into the MicroHAWK reader of your choice with the ideal dimensions, connectivity, and industrial rating to meet your requirements. Tailor the performance of these readers to meet the exact requirements of any barcode reading application and optimize size, connectivity, and cost-efficiency. From omnidirectional decoding of 1D barcodes to tough, low-contrast 2D symbols, any MicroHAWK reader can be engineered with the exact features you need.



SENSOR:
WVGA, SXGA
or QSXGA



DECODER:
Standard, Plus
or X-Mode



SPEED:
Standard or
High-Speed



LENS:
Standard or
High-Density



LIGHTING:
Inner/Outer;
Red or White LEDs

Incredibly Intuitive

Experience is optional. MicroHAWK barcode readers are the easiest industrial devices to set up and install. Begin reading right out of the box within seconds. Just connect power, open a web browser, and get started decoding. Use a PC, laptop, tablet, or any device with a web browser to set up a reader and view decoded data and barcode images in real time using WebLink, Microscan's intuitive user interface. Make adjustments to reader settings without physical access to the reader itself. With the most intuitive controls of any barcode setup interface, WebLink finally brings the age of usability to industrial barcode reading.

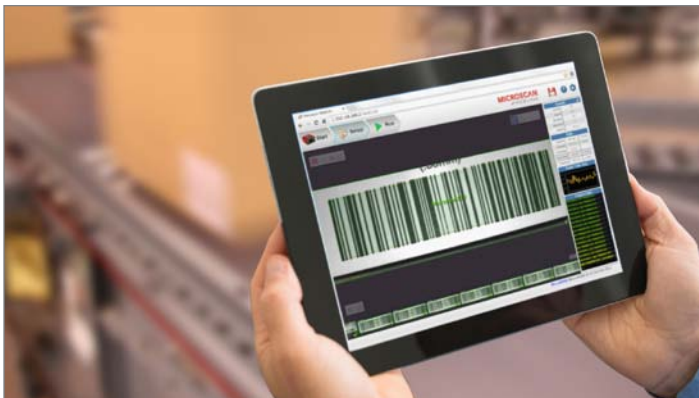

2772

Possible hardware/software combinations to solve **ANY** barcode application

1



2



3





- Ultra-compact (19.5 mm x 28.7 mm x 33.9 mm)
- USB 2.0 high speed, Ethernet over USB
- X-Mode 4.0 advanced decoding algorithms
- Integrated targeting and read/pass indicators
- Programmable red or white LED illumination
- WebLink browser-based setup interface

AVAILABLE DECODERS

- Standard: High-contrast 1D barcodes
- Plus: High-contrast 1D/2D barcodes
- X-Mode: All 1D/2D, including damaged or poorly-printed barcodes

AVAILABLE ILLUMINATION

- Inner: 8 LEDs are standard on all ID-20s (red or white)

ID-20 OEM Barcode Reader

The world's smallest full-featured and fully-integrated barcode imager, ID-20 offers OEMs and traceability engineers a perfect set of value and performance options in a tiny, simple, and streamlined solution for embedded designs or WIP traceability.

ID-20, the only reader of its kind, offers a single cable solution that uses USB for both communication (USB 2.0 high speed and Ethernet over USB) and power to enable plug-and-play integration. Mini is now micro and incredibly easy to use.

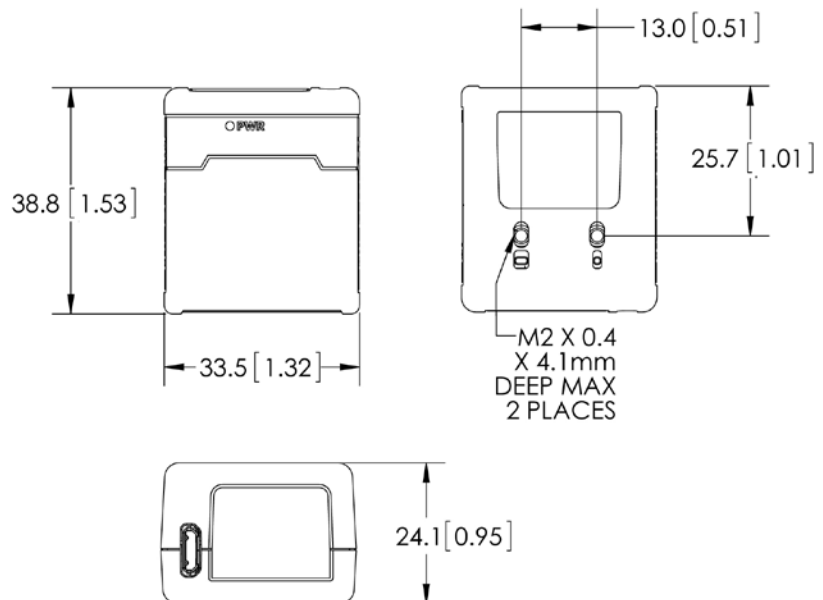

APPLICATION EXAMPLES

- Life sciences and clinical instrumentation
- Laboratory automation and dispensing
- Electronics assembly and test
- Kiosk and ticketing



Note: Specifications are subject to change.

For complete technical information, please see the User Manual available at www.microscan.com.

ID-30 Miniature Barcode Reader

A micro-sized barcode imager with huge potential, the ID-30 continues Microscan's 30+ year legacy of innovative space-efficient miniature design with a corner exit cable and high-density 15-pin connector (serial, USB 2.0 high speed and Ethernet over USB capabilities).

Perfect for OEMs and machine builders, the ID-30 offers the perfect combination of size, performance, and flexible integration. The ID-30 outperforms any reader in its class and is the ideal solution for automation engineers looking for incredible performance in a micro-sized product.

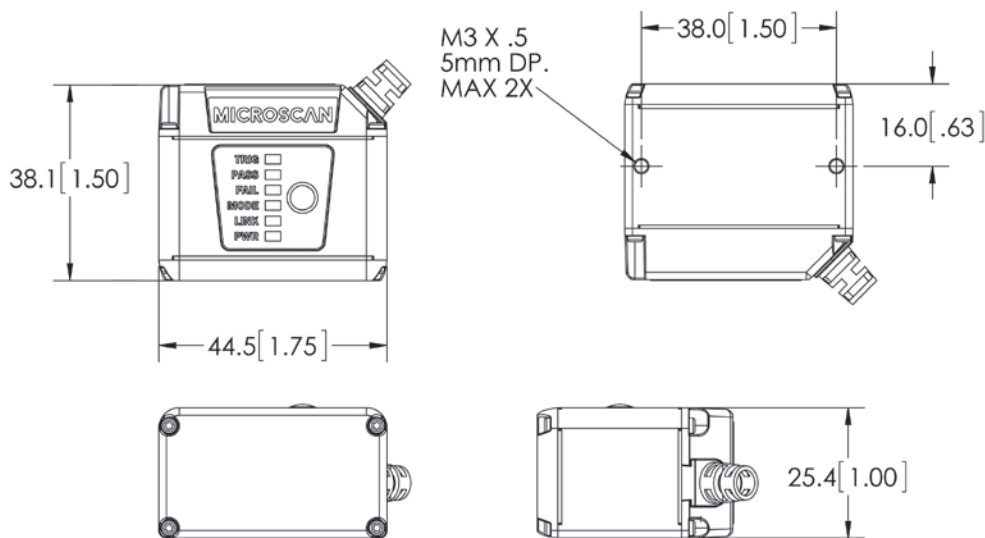

APPLICATION EXAMPLES

- *Clinical instruments:*
 - Embedded barcode reading
 - Sample tracking and vial reading
- *Medical devices:*
 - Dot peen or laser marks on products
- *Electronics:*
 - Laser markings on PCBs
 - Sub-assembly tracking
- *Semiconductors:*
 - Laser marks on packages and components



- *Ultra-compact (44.5 mm x 38.1 mm x 25.4 mm)*
- *Serial, USB 2.0 high speed, Ethernet over USB*
- *X-Mode 4.0 advanced decoding algorithms*
- *Integrated targeting and read/pass indicators*
- *Programmable red or white LED illumination*
- *WebLink browser-based setup interface*

AVAILABLE DECODERS

- *Standard: High-contrast 1D barcodes*
- *Plus: High-contrast 1D/2D barcodes*
- *X-Mode: All 1D/2D, including low-contrast, damaged or poorly-printed barcodes; Direct Part Marks (DPM)*

AVAILABLE ILLUMINATION

- *Inner: 8 LEDs are standard on all ID-30s (red or white)*
- *Outer: 8 additional high-output LEDs are optional; available in red or white*

Note: Specifications are subject to change.

For complete technical information, please see the User Manual available at www.microscan.com.



- Ultra-compact (44.5 mm x 44.5 mm x 25.4 mm)
- High-speed Ethernet, serial (RS-232)
- X-Mode 4.0 advanced decoding algorithms
- Integrated targeting and read/pass indicators
- Programmable red or white LED illumination
- WebLink browser-based setup interface

AVAILABLE DECODERS

- Standard: High-contrast 1D barcodes
- Plus: High-contrast 1D/2D barcodes
- X-Mode: All 1D/2D, including low-contrast, damaged or poorly-printed barcodes; Direct Part Marks (DPM)

AVAILABLE ILLUMINATION

- Inner: 8 LEDs are standard on all ID-40s (red or white)
- Outer: 8 additional high-output LEDs are optional; available in red or white

ID-40 Industrial Ethernet Barcode Reader

A revolutionary new product, the ID-40 redefines the imager market as the smallest IP65, true-industrial Ethernet barcode reader. With best-in-class decoding technology for 1D/2D or DPM codes in a rugged, ultra-compact case, the ID-40 is the complete package for solving any barcode reading challenge under any conditions.

Combining unprecedented ease-of-use, exceptional decode performance, and ultra-small form factor, the ID-40 sets the benchmark as the ultimate compact imager in the industry.

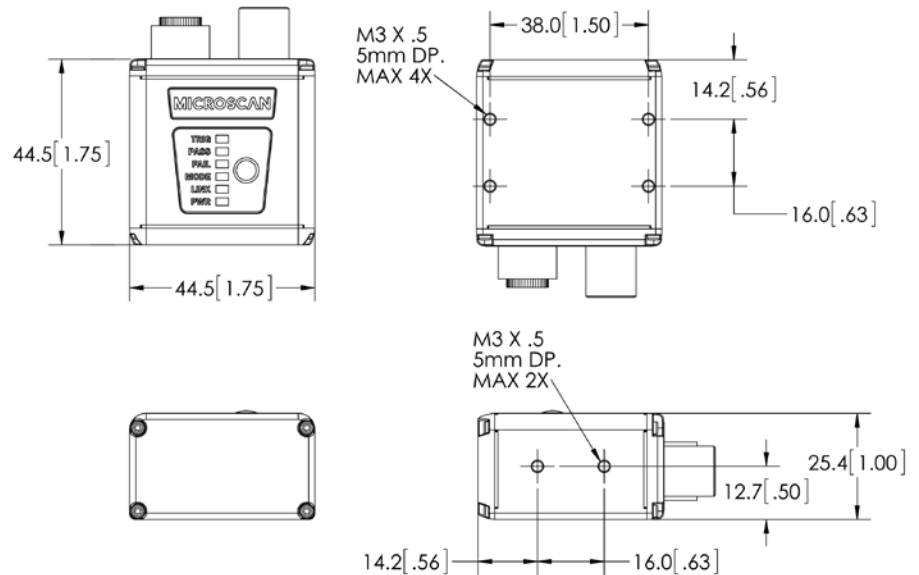

APPLICATION EXAMPLES

- Assembly line manufacturing
- Component tracking
- Automotive:
 - Dot peen on powertrain components
 - Laser marks on automotive electronics
- Medical devices:
 - Laser marks on components
- Electronics:
 - Laser markings on PCBs
- Semiconductors:
 - Laser marks on packages and components



Note: Specifications are subject to change.

For complete technical information, please see the User Manual available at www.microscan.com.

WebLink User Interface

Set up, test, control, and monitor your MicroHAWK reader from the web browser of your choice using Microscan's WebLink user interface. Simply enter your reader's IP address on any web-enabled device and follow an intuitive setup process to gain access to reader controls.

Decode single, multiple, static, moving, or directly-marked codes and even train the interface to adjust for challenging lighting conditions and damage. With WebLink, you can access any MicroHAWK reader's settings in real-time without software or physical adjustment of the camera.

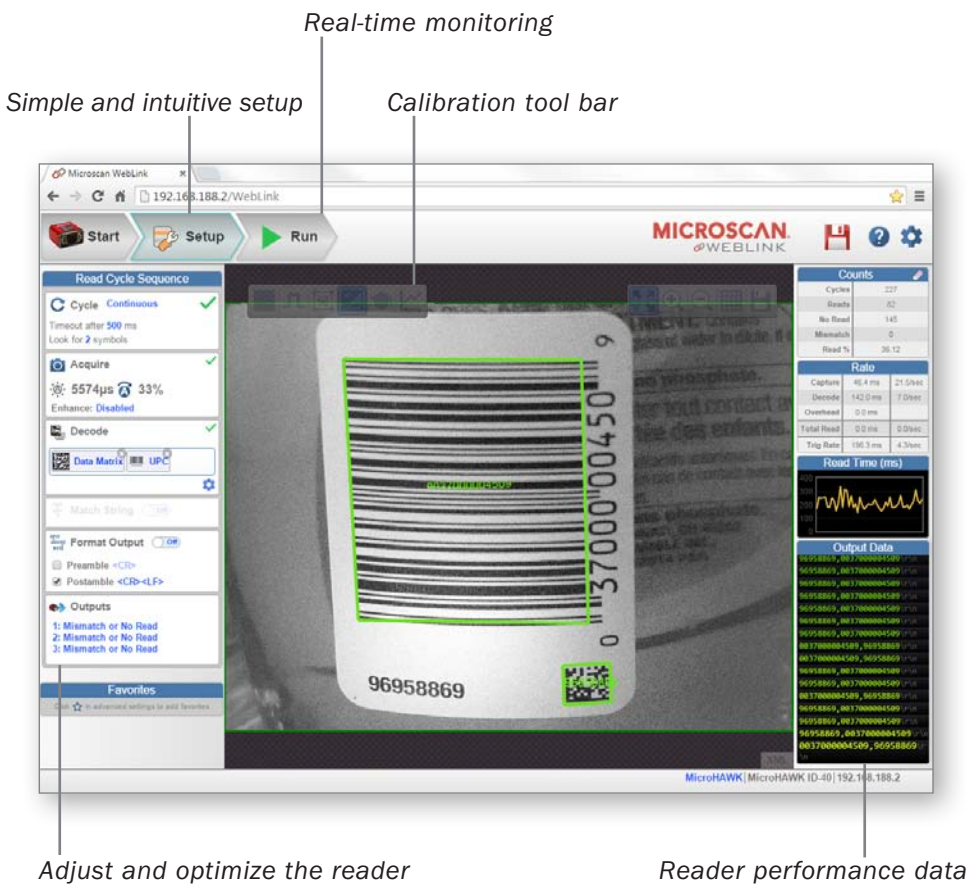

- World's first browser-based setup interface for industrial barcode reading
- No software to download or install
- One-click symbol training and optimization tools
- Best-in-class useability
- Real-time remote access to reader settings and results
- Common setup interface across all MicroHAWK readers

Superior Barcode Reading for Any Industry

Data accuracy and reliability are critical for modern manufacturers. MicroHAWK barcode readers offer the widest range of hardware options available to meet any industrial need, all within a miniature form factor that has virtually unlimited integration potential.

With no software to install, and no compatibility obstacles, MicroHAWK solves the toughest barcoding challenges for manufacturers in a diverse range of applications and industries around the world.

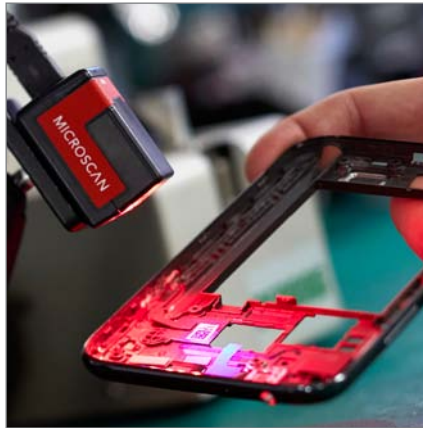

ELECTRONICS

- Component and PCB traceability
- Sub-assembly tracking
- Automated line changeover
- Quality assurance
- WIP tracking

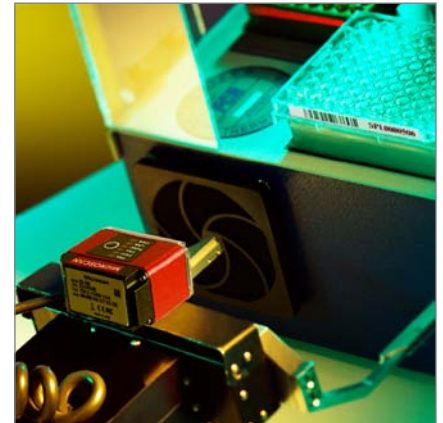

LIFE SCIENCES

- Sample tracking
- Medical device tracking
- Test level traceability
- Vial reading and verification



PACKAGING:

- Match inserts to packaging
- Item traceability
- Quality assurance
- Anti-counterfeiting measures
- Package sortation
- Carton coding
- Print and apply

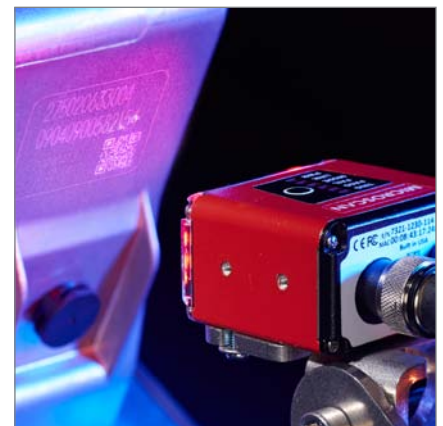

OTHER INDUSTRIES:

- Automotive
- Aerospace
- DoD and IUID
- Contract manufacturing
- Document handling
- Kiosks and self-service terminals

MicroHAWK Product Specifications

	ID-20	ID-30	ID-40
DECODER	Standard (High-Contrast 1D)	Standard (High-Contrast 1D)	Standard (High-Contrast 1D)
	Plus (High-Contrast 1D/2D)	Plus (High-Contrast 1D/2D)	Plus (High-Contrast 1D/2D)
	X-Mode (Poor or Damaged 1D/2D)	X-Mode (Poor or Damaged 1D/2D + DPM)	X-Mode (Poor or Damaged 1D/2D + DPM)
SPEED	Standard	Standard or High-Speed	Standard or High-Speed
DENSITY	Standard or High-Density	Standard or High-Density	Standard or High-Density
SENSOR (CMOS)	WVGA 0.34MP (752x480) Global Shutter, up to 60 FPS	WVGA 0.34MP (752x480) Global Shutter, up to 60 FPS	WVGA 0.34MP (752x480) Global Shutter, up to 60 FPS
	SXGA 1.2MP (1280x960) Global Shutter, up to 42 FPS	SXGA 1.2MP (1280x960) Global Shutter, up to 42 FPS	SXGA 1.2MP (1280x960) Global Shutter, up to 42 FPS
	QSXGA 5.0MP (2592x1944) Rolling Shutter, up to 5 FPS	QSXGA 5.0MP (2592x1944) Rolling Shutter, up to 5 FPS	QSXGA 5.0MP (2592x1944) Rolling Shutter, up to 5 FPS
COLOR	QSXGA only	QSXGA only	QSXGA only
FOCUS	Fixed Focus (Factory Adjustable 50-300 mm)	Fixed Focus (Factory Adjustable 50-300 mm)	Fixed Focus (Factory Adjustable 50-300 mm)
CONNECTIVITY	USB 2.0 High Speed, Ethernet over USB	RS-232, USB 2.0 High Speed, Ethernet over USB	RS-232, Ethernet TCP/IP, EtherNet/IP
CONNECTOR	Micro-B USB	High-Density 15-Pin D-Sub	M12 12-Pin Power, M12 8-Pin Ethernet
CABLE	N/A	0.91 m	N/A
ILLUMINATION	Inner LEDs: 4 White and 4 Red	Inner LEDs: 4 White and 4 Red	Inner LEDs: 4 White and 4 Red
	Outer LEDs: N/A	Outer LEDs: 8 High-Output White or Red (Optional)	Outer LEDs: 8 High-Output White or Red (Optional)
DISCRETE I/O	N/A	3 in/3 out	3 in/3 out, Optoisolated
ELECTRICAL	5 VDC \pm 5 %, 350 mA at 5 VDC (typ.)	5 VDC \pm 5 %, 600 mA at 5 VDC (typ.)	4.75-30 VDC, 200 mV p-p max ripple, 150 mA at 24 VDC (typ.)
DIMENSIONS	24 mm x 34 mm x 39 mm	25 mm x 45 mm x 38 mm	25 mm x 45 mm x 45 mm
WEIGHT	26 g	46 g (Excluding Cable)	68 g
ENCLOSURE	IP40, Plastic	IP54, Aluminum	IP65/67, Aluminum
INDICATORS	Target Pattern, Good Read Green Flash	Target Pattern, Good Read Green Flash, Performance LEDs	Target Pattern, Good Read Green Flash, Performance LEDs

SYMBOLOGIES

2D Symbologies: Data Matrix (ECC 0-200), QR Code, Micro QR Code, Aztec Code **Stacked Symbologies:** PDF417, Micro PDF417, GS1 Databar (Composite & Stacked) **Linear Barcodes:** Code 39, Code 128, BC 412, I2 of 5, UPC/EAN, Codabar, Code 93, Pharmacode, PLANET, PostNet, Japanese Post, Australian Post, Royal Mail, Intelligent Mail, KIX

LIGHT SOURCE

Type: High-output LEDs **Output Wavelength:** Inner Red: 625 nm nominal; Outer Red: 617 nm nominal **Operating Life:** 50,000 hours @ 25° C

ENVIRONMENTAL

Operating Temperature: 0° to 40° C (32° to 104° F) **Storage Temperature:** -50° to 75° C (-58° to 167° F) **Humidity:** 5% to 95% (non-condensing)

EMISSIONS: EN 55022:2010 Class A Limits

SAFETY & QUALITY: Certifications: FCC, CE **RoHS Compliant:** Yes **QMS Certification:** www.microscan.com/quality

Note: Specifications are subject to change. For complete technical information, please see the User Manual available at www.microscan.com.

Barcode | Machine Vision | Lighting

From high-speed barcode reading to high-accuracy guidance, position, and product inspection using machine vision, Microscan products are the most powerful precision devices for complex quality control in automated operations. Our brands, such as Visionscape®, NERLITE®, AutoVISION®, and MicroHAWK™ are globally recognized for quality and usability. Microscan's product families offer comprehensive solutions for any data acquisition need.

■ Barcode Readers

- 1D Barcode Laser Scanners · 1D and 2D Barcode Engines
- 2D Barcode Imagers · DPM Imagers · Handheld Barcode Readers

■ Verification Solutions

- Barcode and Print Quality Verifiers · Handheld Verifiers
- Verification Software

■ Machine Vision

- Machine Vision Smart Cameras · GigE Cameras
- Machine Vision Software

■ Machine Vision Lighting

- Spot Lights · Backlights · Ring Lights · Smart Series Lights



MICROSCAN®

www.microscan.com | info@microscan.com

■ United States
Corporate Headquarters
700 SW 39th St.
Renton, WA 98057
(T) 425-226-5700/800-251-7711
(F) 425-226-8250

■ Europe
European Headquarters
Lemelerberg 17
NL-2402 ZN Alphen aan den Rijn
The Netherlands
(T) 31-172-4233-60
(F) 31-172-4233-66

■ Singapore
Asia Pacific Headquarters
31 Kaki Bukit Road 3 #05-08
TechLink, Singapore 417818
(T) 65-6846-1214
(F) 65-6496-0354