

Installation, Operation
and Maintenance
Instructions for

Copper Brute

Volume Water Heaters

Model B4

Sizes 175-400

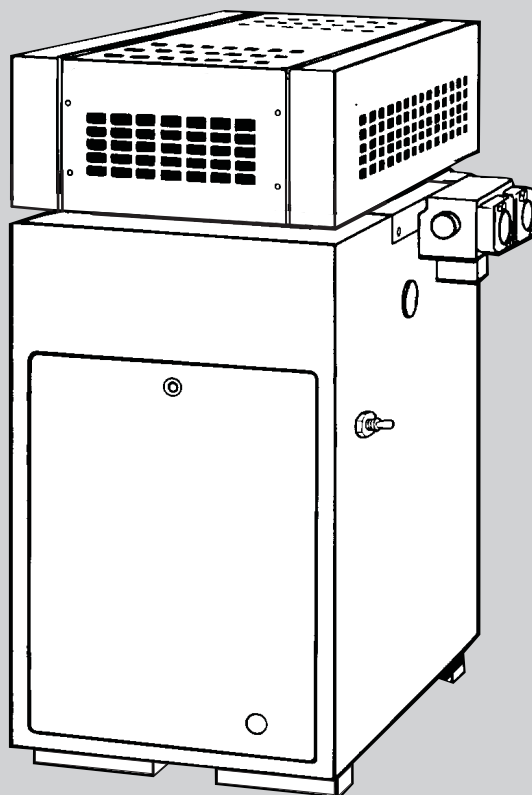

FOR YOUR SAFETY: This product must be installed and serviced by a professional service technician, qualified in hot water heater installation and maintenance. Improper installation and/or operation could create carbon monoxide gas in flue gases which could cause serious injury, property damage, or death. Improper installation and/or operation will void the warranty.

⚠WARNING

If the information in this manual is not followed exactly, a fire or explosion may result causing property damage, personal injury or loss of life.

Do not store or use gasoline or other flammable vapors and liquids in the vicinity of this or any other appliance.

WHAT TO DO IF YOU SMELL GAS

- Do not try to light any appliance.
- Do not touch any electrical switch; do not use any phone in your building.
- Immediately call your gas supplier from a nearby phone. Follow the gas supplier's instructions.
- If you cannot reach your gas supplier, call the fire department.

Installation and service must be performed by a qualified installer, service agency, or gas supplier.

TABLE OF CONTENTS

SECTION 1.

General Information

1.1	Introduction.....	3
1.2	Warranty.....	3
1.3	Technical Assistance.....	3

SECTION 2.

Installation Instructions

2.1	General Information.....	4
2.2	Field Assembly.....	4
2.3	Site Location.....	5
2.3.1	Installation Information.....	5
2.3.2	Outdoor Installation (U.S. only).....	5
2.3.3	Flooring - Typical Installation.....	6
2.4	Combustion and Ventilation Air Supply.....	6
2.4.1	Outdoor Air Supply.....	7
2.4.2	Indoor Air Supply.....	7
2.4.3	Exhaust Fans or Vents.....	7
2.5	Venting of Combustion Products.....	8
2.5.1	General Information.....	8
2.5.2	Replacement of Existing Heater.....	8
2.6	Water Flow.....	8
2.6.1	Reversible Water Connections.....	8
2.6.2	Water Chemistry.....	11
2.6.3	Freeze Protection.....	11
2.6.4	Water Hardness.....	11
2.6.5	Pump Requirements.....	11
2.6.6	Pressure Buildup in Water System.....	14
2.6.7	Pressure Relief Valve.....	14
2.6.8	Water Pressure.....	14
2.6.9	Pump Installation.....	14
2.6.10	Storage Tank Installation.....	15
2.6.11	Thermal Circulation of Hot Water in Cold Water Supply Lines.....	15
2.7	Gas Supply and Piping.....	15
2.7.1	General Instructions.....	15
2.7.2	Special Precautions for Propane Gas.....	16
2.8	Electrical Wiring.....	16
2.9	Combined Space Heating/Potable Water Heating Systems.....	16
2.9.1	Combined Space Heating.....	16

SECTION 3.

Operating Instructions

3.1	Normal Operating Sequence.....	16
3.2	Start-Up Procedure.....	21
3.3	Setting the Temperature Controls.....	21
3.3.1	Remote Water Heater Temperature Control:.....	21
3.3.2	Internal Water Heater Temperature Control:.....	22
3.4	Adjustment for Minimum Input Rate (models with modulating gas valve).....	22

3.5	Hi-Limit Switch Checkout.....	22
3.6	Shut-Down Procedure.....	22

SECTION 4.

Maintenance

4.1	General Instructions.....	23
4.2	Replacement of Gas Controls.....	23
4.3	Heat Exchanger.....	25
4.3.1	Inspecting the Heat Exchanger.....	25
4.3.2	Cleaning the Heat Exchanger.....	25

SECTION 5.

Troubleshooting

5.1	Gas Pressure Tests.....	26
5.1.1	Checking the Main Line Gas Pressure.....	26
5.1.2	Checking the Manifold Regulated Gas Pressure.....	26
5.2	Electrical Troubleshooting.....	26
5.2.1	Heater Does Not Come On.....	27
5.2.2	Testing the Transformer.....	27
5.2.3	Testing the Electrical Power Supply.....	28
5.2.4	Testing the Manual Reset Hi-Limit Switch.....	28
5.2.5	Testing the Flow Switch.....	28
5.2.6	Testing the Fusible Link (Flame roll-out switch).....	28
5.2.7	Testing the Fuse.....	29
5.2.8	Testing the Ignition Control (for spark ignition).....	29
5.2.9	Testing the High Voltage Ignition Lead.....	29
5.2.10	Testing the Safety Shutoff (for standing pilot).....	30
5.2.11	Testing the Safety Shutoff (for automatic pilot).....	30
5.2.12	Testing the Igniter Electrode.....	30
5.2.13	Testing the Pilot Thermocouple (for standing pilot).....	30
5.2.14	Testing for Pilot burner (for spark ignition).....	30
5.2.15	Testing for Burner Ignition (for standing pilot).....	31
5.2.16	Heater Will Not Shut Off.....	31
5.2.17	On-Off Main Burner Cycling.....	31
5.2.18	Testing the Terminal Strip/External Controls.....	31

SECTION 1. General Information

1.1 Introduction

This manual provides installation, operating, and maintenance instructions for Copper Brute Volume Water Heaters, Sizes 175 through 400. Review all application and installation procedures completely before proceeding with the installation. Experience has shown that most operating problems are caused by improper installation.

1.2 Warranty

The Copper Brute heaters are sold with a limited factory warranty.

Make all warranty claims to an authorized Bradford White representative or directly to the factory. Claims must include the heater serial number and model (this information can be found on the rating plate), installation date, and name of the installer. Shipping costs are not included in the warranty coverage.

Some accessory items are shipped in separate packages. Inspect everything for damage immediately upon delivery, and advise the transporter of any shortages or damage. Any such claims should be filed with the transporter. The transporter will not accept a claim from the shipper, Bradford White.

The warranty does not cover damage caused by improper installation, operation, or field modification.

1.3 Technical Assistance

Consult Bradford White or your local wholesaler with any questions or problems involving the specification, installation and operation of Bradford White equipment. An experienced technical support staff is ready to assist in assuring the proper performance and application of Bradford White products.

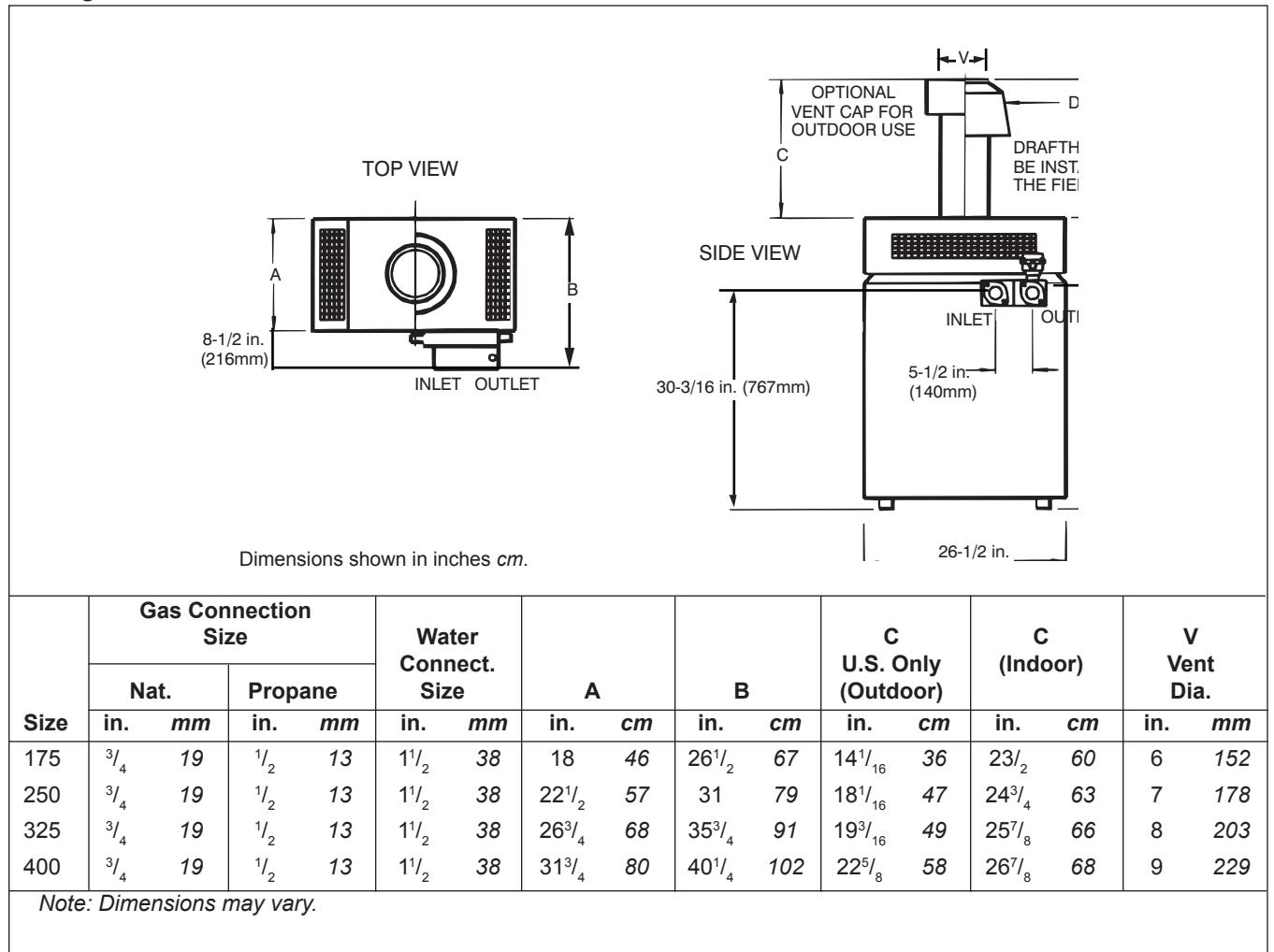

Figure 1. General configuration.

SECTION 2. Installation Instructions

2.1 General Information

⚠ WARNING

Follow local regulations with respect to installation of carbon monoxide (CO) detectors and manufacturer's maintenance schedule of the heater.

Install the Copper Brute heaters in accordance with the procedures in this manual (or the warranty may be voided), local codes and ordinances. In the absence of such codes, install the heaters in accordance with the latest edition of the National Fuel Gas Code, ANSI Z223.1. In Canada, the installation must be in accordance with CAN1-B149.1 or .2 and local codes. The authority having jurisdiction may require the installation conform to the Standard for Controls and Safety Devices for Automatically Fired Heaters, ANSI/ASME CSD-1. Any changes to the heater, gas controls, gas orifices, wiring or draft diverter may void the warranty. If field conditions require a change to any of the above, consult the factory.

All gas-fired products require correct installation to assure safe operation. The requirements for heaters include the following:

1. Field assembly of draft hood or vent cap (see Section 2.2).
2. Appropriate site location (clearances) and flooring.
3. Sufficient combustion and ventilation air.
4. Adequate venting of combustion products.
5. Adequate water flow.
6. Properly sized gas meter and piping.
7. Proper electrical wiring.

This manual provides the information needed to meet these requirements. Review all application and installation procedures completely before continuing the installation.

2.2 Field Assembly

The Copper Brute heater is shipped from the factory with the top assembly in the low-profile configuration for outdoor installations.

The Copper Brute heater is design certified for indoor installation when equipped with a special draft hood, which must be installed without modification. The part number for the draft hood is on the heater rating plate. Follow this procedure to make the conversion:

- a. Remove the top filler plate, stamped "HOT", by slipping a fine-blade screwdriver into the slot at the rear of the plate and gently prying it up (see Figure 2).
- b. Remove the two screws attaching the adapter plate to the top assembly and lift it out (see Figure 3).
- c. Remove the vent cap or draft hood from its package.
- d. Disengage the flue transition ring from the stack extension and place it on top of the collector assembly as shown in Figure 4.



Figure 2. Top filler plate.

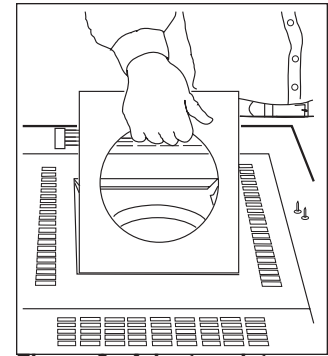

Figure 3. Adapter plate.

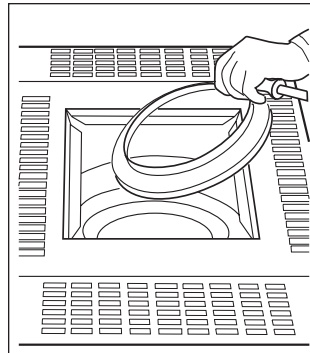

Figure 4. Flue transition ring.



Figure 5. Vent cap with adapter plate (outdoor).

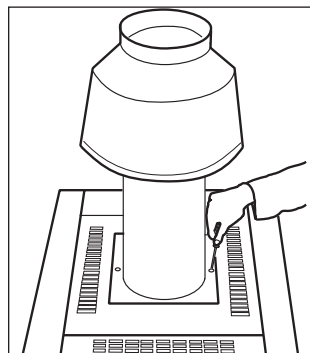

Figure 6. Draft hood with adapter plate (indoor).

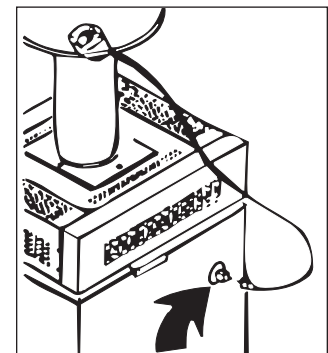

Figure 7. Draft hood switch receptacle.

- e. Slide the adapter plate over the bottom of the stack extension as shown in Figure 5. Fit the stack extension down over the flue transition ring. Seat the adapter plate on the top assembly and secure it with two screws (see Figure 6).
- f. Indoor models, size 175 and 250 only, require an adapter cable (included with product). The cable connects the blocked vent safety switch (BVSS) on the bell of the external draft hood to the 6-position Molex plug on the side of the unit (see Figure 7). Refer to instruction sheet included with cable.

2.3 Site Location

2.3.1 Installation Information

⚠ WARNING

Improper installation or maintenance can cause nausea or asphyxiation from carbon monoxide in flue gases which could result in severe injury, property damage, or death.

Avoid placing the heater in locations where it can be damaged by water or condensate leakage. If this is not possible, provide a suitable drain pan to catch and divert any leakage. The pan must not block natural flow of air around the heater.

Locate the heater to provide adequate clearance on all sides for inspection, service and to provide adequate air circulation for proper operation.

Locate the heater so the clearances from combustible surfaces shown in Table 1 and Figure 8 are met.

Locate the heater on a waterproof floor with a floor drain and a 6 inch (152 mm) minimum curb on all four sides to protect the building if heater repairs are needed.

Clearance from:	Indoors		Outdoors	
	inch	mm	inch	mm
Top	37	940	Unobstructed	
Water conn. side	12	305	Unobstructed	
Opposite side	6	152	6	152
Front	Alcove		Unobstructed	
Rear	6	152	6	152
Vent*	6	152	—	
Flooring	Combustible		Combustible	

Service clearance = 36 inches (914mm) at front of heater, and 18 inches (457mm) at water connection side.
 *1" (25mm) if double wall vent is used.

Table 1. Minimum Boiler Clearances from Combustible Surfaces.

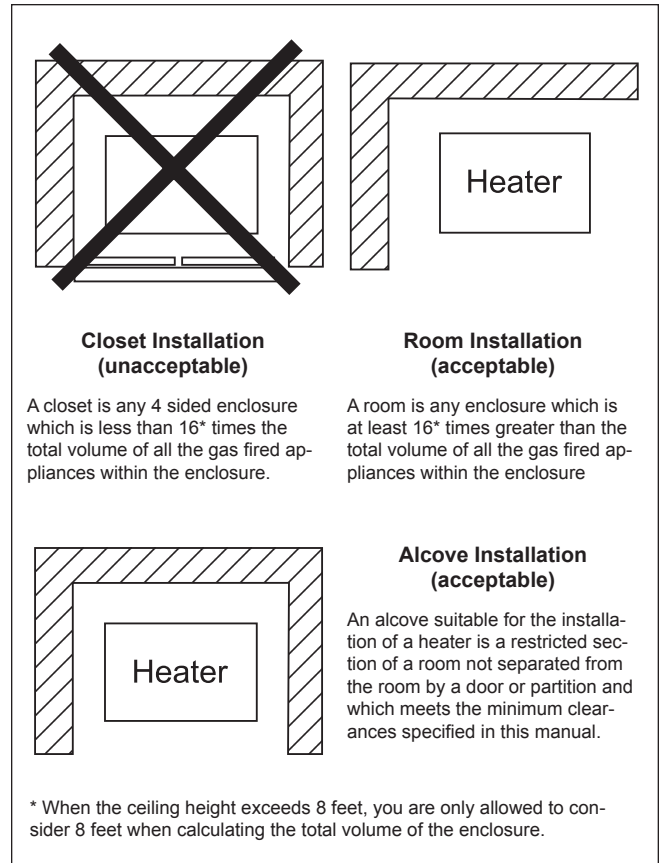

Figure 8. Alcove installation.

2.3.2 Outdoor Installation

⚠ Caution

Outdoor installations are not recommended in areas where the danger of snow blockage exists. Copper Brute heaters can be installed in the standard low-profile, grate top configuration as received from the factory, or with an optional vent cap.

Locate the heater in an open, unroofed area. Do not locate the heater below or adjacent to any doors, windows, louvers, grills, etc., which connect in any way with an inhabited area of a building, even though the access might be through another structure such as a garage or utility room (see Figure 9 and Table 1). There must be a minimum of 4 feet (1.22 m) horizontally and vertically between the heater and any door, window, or gravity inlet to a building (see Figure 10).

If the heater is installed close to a structure, protect it from rain water runoff with rain gutters on the roof or other measures. Do not locate the heater near sprinkler systems that could spray water on it.

Avoid locations where wind deflection off nearby structures might cause wind loading and downdraft conditions. Where downdraft conditions exist, locate the heater at least 3 feet (0.91 m) from the structure.

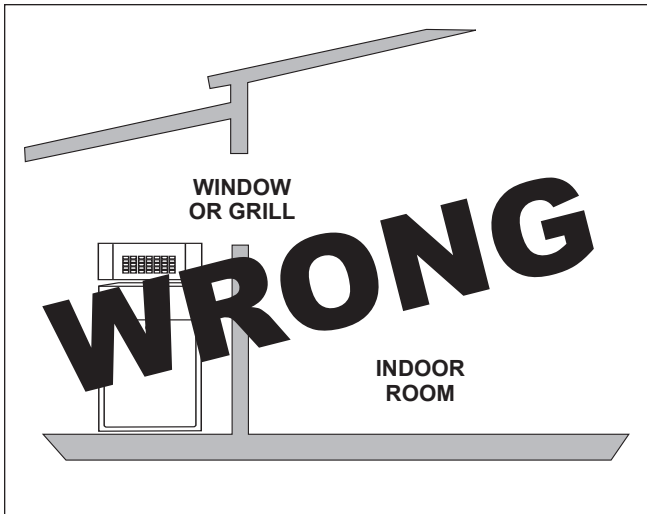

Figure 9. Incorrect outdoor installation.

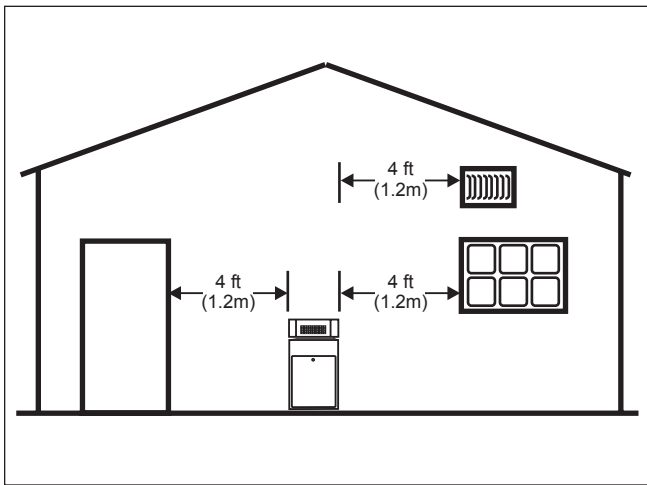

Figure 10. Outdoor location installation.

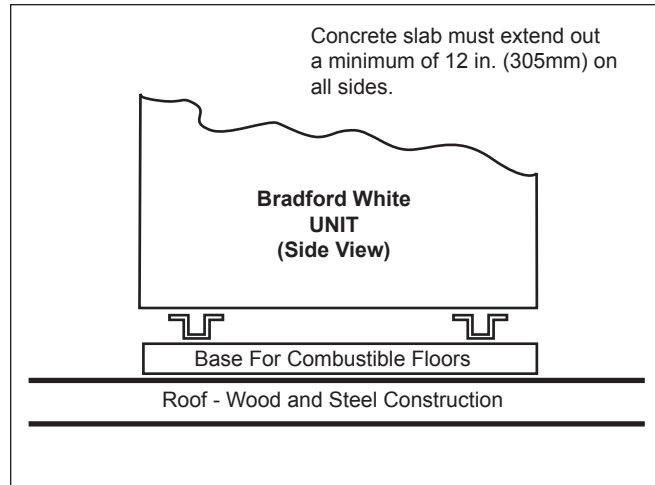

Figure 11. Standard base for combustable floor.

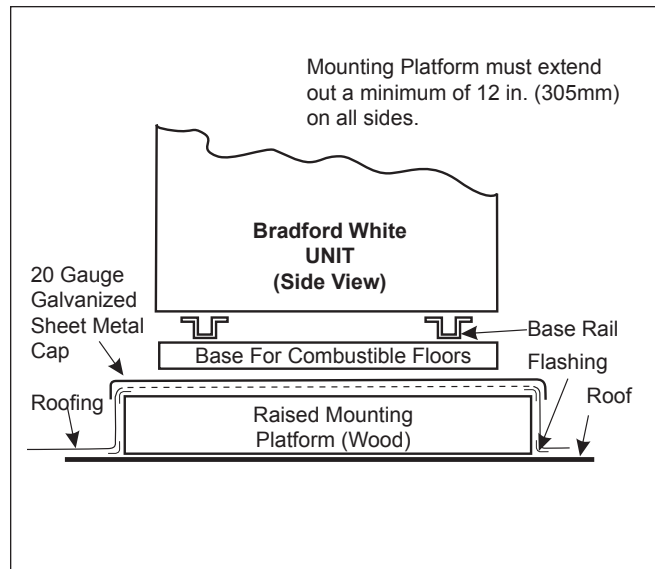

Figure 12. Typical roof mounting.

2.3.3 Flooring - Typical Installation

Do not install the heater directly on carpeting without placing a non-combustible platform between the carpeting and the heater. If the heater is installed in a carpeted alcove, the entire floor of the alcove must be covered by a non-combustible panel. The panel must be strong enough to carry the total weight of the heater and all piping, pumps, and any other equipment attached to the heater. For rooftop installation, see Figure 11 through Figure 13.

2.4 Combustion and Ventilation

Air Supply

All indoor installations must have openings to outside air for combustion, ventilation and dilution of flue gases from inside the building (see Figure 14 and Table 2). Bradford White does not recommend indoor installations that do not provide combustion air from outside the building.

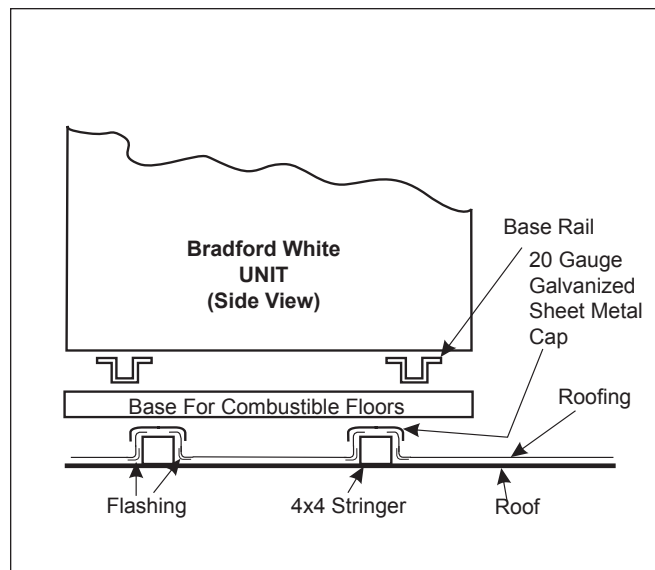

Figure 13. Typical roof mounting with standard combustable mount base.

Mode	Required Net Free Opening Area Directly from Outside			
	At Top		At Bottom	
	in. ²	cm ²	in. ²	cm ²
175	44	284	44	284
250	63	406	63	406
325	82	529	82	529
400	100	645	100	645

Note: For screens or louvers, add 50%.

Table 2. Air Openings to Outside.

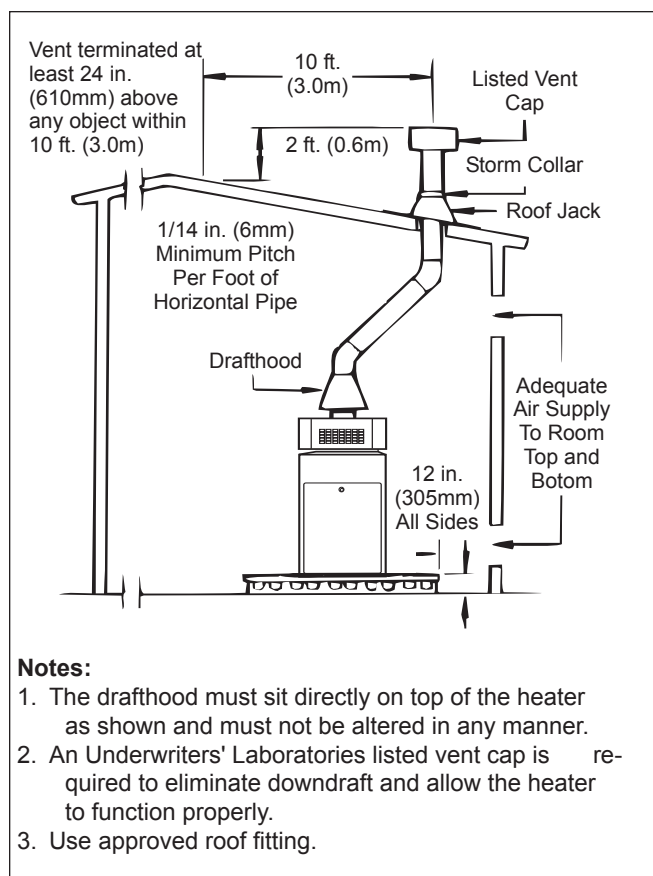

Figure 14. Indoor installation and venting.

In the United States, the most common requirements specify that the space shall communicate with the outdoors in accordance with method 1 or 2, which follow. Where ducts are used, they shall be of the same cross-sectional area as the free area of the openings to which they connect.

Method 1:

Two permanent openings, one commencing within 12" (30 cm) of the top and one commencing within 12" (30 cm) of the bottom of the enclosure shall be provided. The openings shall communicate

directly, or by ducts, with the outdoors or spaces that freely communicate with the outdoors. When directly communicating with the outdoors directly, or through vertical ducts, each opening shall have a minimum free area of 1 square inch per 4000 Btu/hr (550 square mm/kW) of total input rating of all equipment in the enclosure. When communicating to the outdoors through horizontal ducts, each opening shall have a minimum free area of not less than 1 square inch per 2000 Btu/hr (1100 square mm/kW) of total input rating of all equipment in the enclosure.

Method 2:

One permanent opening, commencing within 12" (30 cm) of the top of the enclosure shall be permitted. The opening shall directly communicate with the outdoors or shall communicate through a vertical or horizontal duct to the outdoors or spaces that directly communicate with the outdoors, and shall have a minimum free area of 1 square inch per 3000 Btu/hr (734 square mm/kW) of the total input rating of all equipment located in the enclosure. This opening must not be less than the sum of the areas of all vent connectors in the confined space.

Other methods of introducing combustion and ventilation air are acceptable, providing they conform to the requirements in ANSI Z223.1, or applicable codes.

In Canada, Table 2 does not apply. Consult local building and safety codes or, in absence of such requirements, follow CAN/CGA B149.

NOTE: Check with louver manufacturers for net free area of louvers. If screens or louvers are installed, add 50 percent for each screen/louver to the net free area. Check all local codes applicable to combustion air.

2.4.1 Outdoor Air Supply

When combustion air comes directly through an outside wall, each opening must have a minimum free area of at least one square inch for each 4,000 BTU/h input of the total input rating of all appliances in the enclosed area. (In Canada, refer to CGAB149.1 and .2.)

2.4.2 Indoor Air Supply

Confined and non-confined areas have different requirements for installation. Consult the latest edition of the National Gas Code for installation requirements.

2.4.3 Exhaust Fans or Vents

Any equipment which uses air or removes air from the heater room can use up the combustion air supply or reverse the natural draft action of the venting system. This could cause flue products to build up in the heater room. More air must be supplied to make up for the decrease.

2.5 Venting of Combustion Products

2.5.1 General Information

When installed indoors, the draft hood must be connected to a venting system. The venting system must be installed by a qualified installer and in accordance with the latest edition of ANSI Z223.1. In Canada, the installation must be in accordance with CAN1-B149.1 or .2, and any local codes that apply.

The vent pipe must have a listed vent cap, and extend at least 2 feet (0.6 m) above any object within a 10 foot (3.0 m) radius.

NOTE: Do not use sheet metal screws at the snap lock joints of Type B double-wall gas vents.

Do not weld or bolt the vent pipe to the heater draft hood. The weight of the stack must not rest on the heater. The draft hood and heater top must be easily removable for normal heater service and inspection.

WARNING

Avoid ending heater vents near air conditioning or air supply fans. The fans can pick up exhaust flue products from the heater and return them inside the building, creating a possible health hazard.

Avoid horizontal runs of the vent pipe and 90 degree elbows, reductions, and restrictions. Horizontal runs should have at least a 1/4 inch (6.3 mm) rise per foot in the direction of flow. Support a vent connector for the design and weight of the material used to maintain clearances and physical damage and separate of joints.

Always use double-wall or insulated vent pipe (Type B or equivalent).

WARNING

In cold weather, uninsulated outside vents can chill the rising flue products, blocking the natural draft action of the venting system. This can create a health hazard by spilling flue products into the heater room.

Avoid oversize vent piping or extremely long runs of the pipe which may cause too much cooling and condensation of flue gasses.

When the installation of a power vent or draft fan in the venting system is necessary, qualified personnel should design the installation following good engineering practices and all applicable codes. A suitable draft switch must be wired into the heater control circuit at the terminal designated Field Interlock to keep the heater from firing unless there is a positive draft.

2.5.2 Replacement of Existing Heater

When a heater is removed from a common venting system, the venting system may be too large for proper venting of the other appliances connected to it.

If replacing an existing heater with a Copper Brute heater and the existing heater was connected to a common venting system, the common venting system must comply with ANSI Z223.1/National Fire Protection Association (NFPA) 54. When resizing any portion of the common venting system, the common venting system should be resized to approach the minimum size as determined using the tables in ANSI Z223.1/NFPA 54, Appendix G. In Canada, the common venting system should be resized so the installation will be in accordance with CAN/CGA B149.1 or .2.

2.6 Water Flow

2.6.1 Reversible Water Connections

Bradford White ships the heater with the water connections on the right side. The heater can be installed with the water connections on either side. It could be necessary, or helpful, to switch the connections to the left side to improve access for installation service. Have a professional service technician perform this modification before installing the heater using the following procedures:

1. Remove the front cover.
2. If there is a vent cap or draft hood installed, they must be removed before removing the grate top assembly. On indoor installations (sizes 175-250), the draft hood switch must be disconnected at the left side of the heater.
3. If the unit is in the low-profile outdoor configuration, remove the hex-head screws (see Figure 15) and lift the grate top assembly straight up.
4. Remove the screws that fastens the flue collector holddown clamps and remove the clamps (see Figure 16).
5. Remove the flue collector assembly by lifting it out of the chassis.
6. Remove the screws that fastens the gap closures and put them aside.
7. Remove the three grommets.
8. Remove the drain valves and plug. There is one hex plug on the left side, near the rear of the jacket. The drain valves are located on the left side and right side of the heater (see Figure 15).
9. Remove the four screws that fastens the metal channels covering the capillary tube on the right side of the jacket, and lay the channels aside.

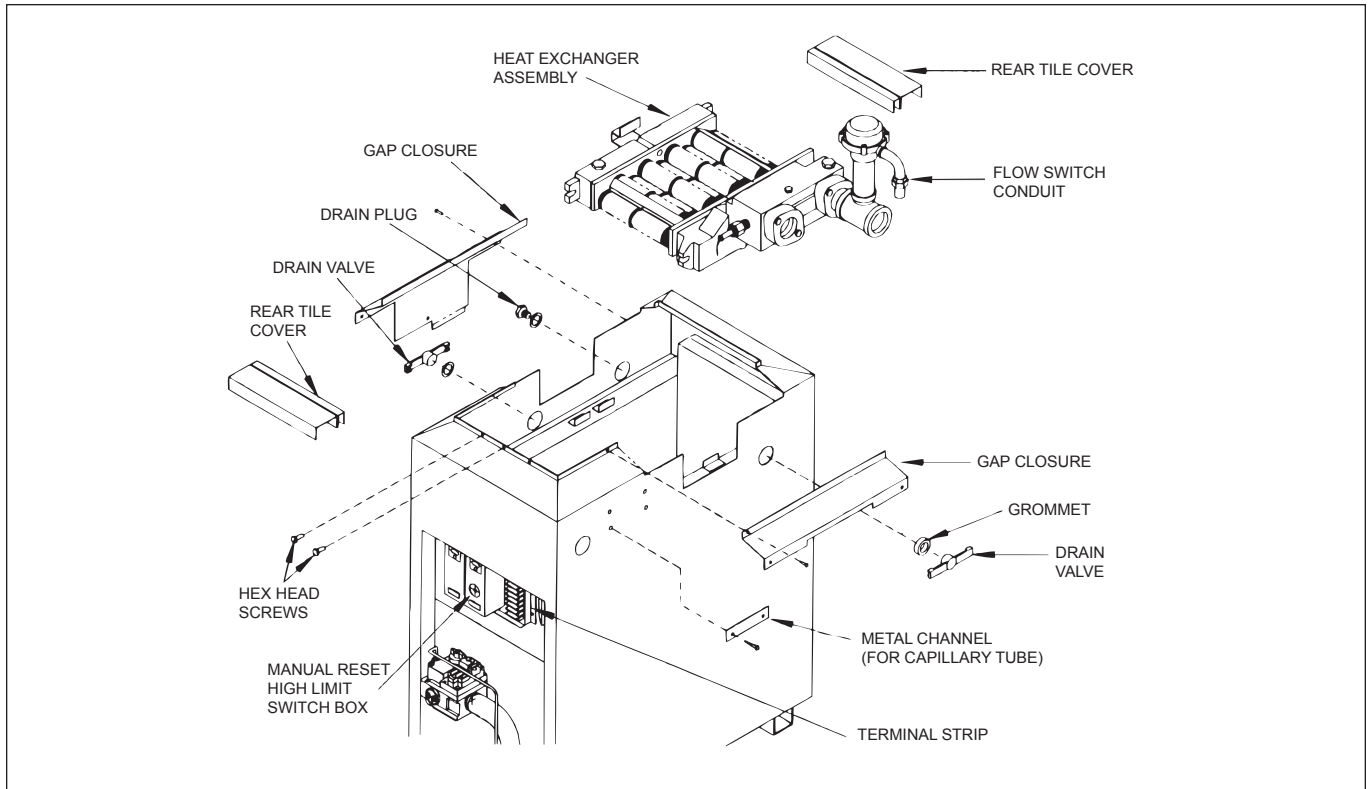

Figure 15. Heat exchanger reversal.

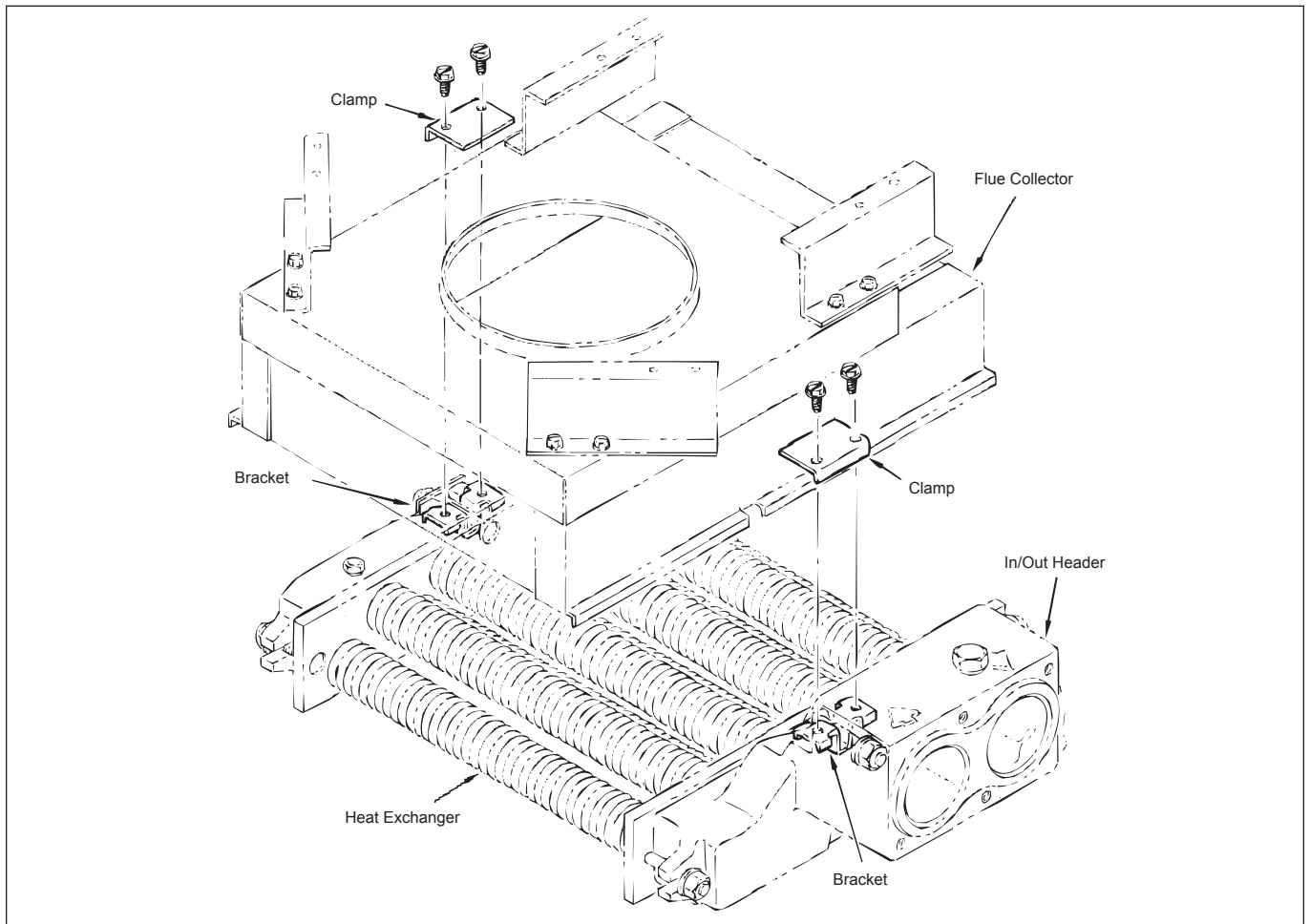

Figure 16. Flue collector Holddown Clamps.

10. In the control compartment, find the manual reset high-limit switch box (see Figure 15) and loosen the screw on the top to remove the cover.
11. Loosen the screw that fastens the white wire and remove it from the terminal. Pull it out through the top of the case and separate the other white wire from the red wire coming from the fuse

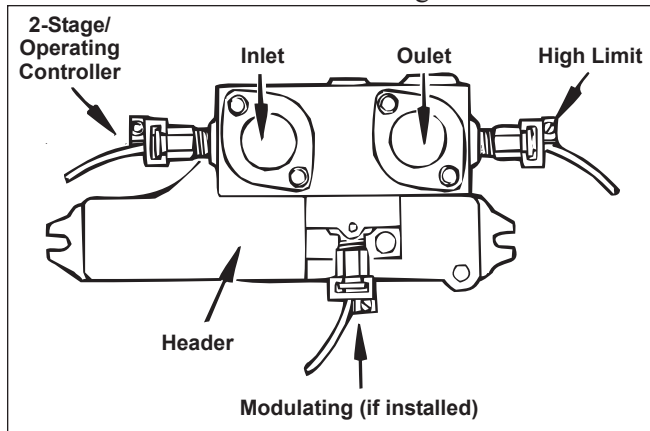

Figure 17. Sensory bulb locations.

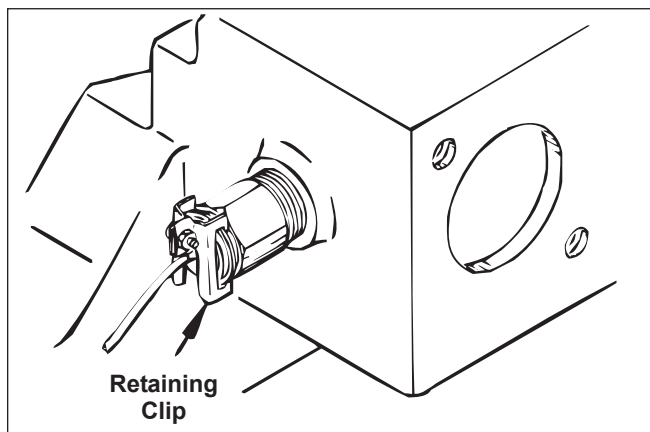

Figure 18. Retaining clip removal.

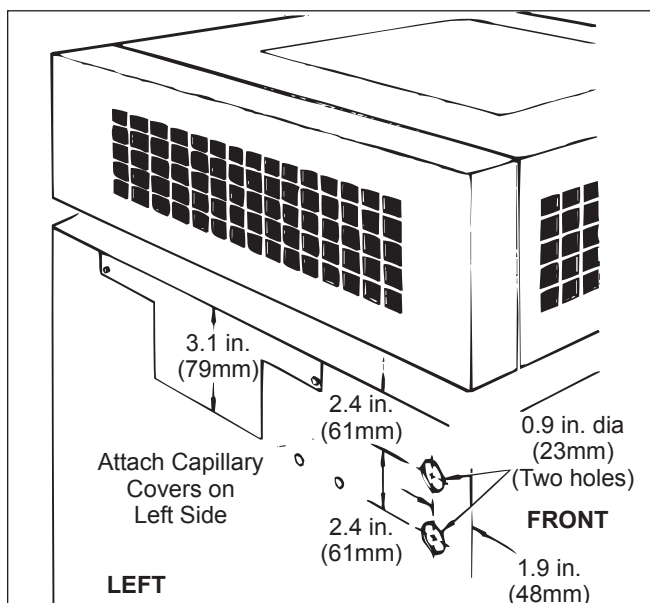

Figure 19. Hole location, left side.

- holder. Gently pull the two white wires out of the control compartment and coil them on top of the heat exchanger.
12. A temperature control sensing bulb is located in the front of the header on the inlet side and a manual reset hi-limit sensing bulb is located on the back side of the header on the outlet side (see Figure 17). Remove these sensing bulbs from the header. The following steps for removal apply to all sensing bulbs:
 - a. If there is more than one capillary tube coming out of the header, label the capillary tubes.
 - b. Loosen the screw on the capillary tube retaining clip, then gently pry the clip apart until it comes free from the temperature control (see Figure 18).
 - c. Pull the sensing bulbs out of the temperature control.
 - d. Gently pull the capillary tubes into the control compartment.
 - e. Pull the temperature sensing bulb out of the header, and temporarily route it to the front of the heater.
13. Use a pair of diagonal cutters to cut the plastic tie around the wire bundle in the control compartment.
14. On the terminal strip, disconnect the two brown wires from No. 5 and No. 6 terminals.
15. Remove the flow switch conduit retaining clip and the elbow leading into the jacket.
16. Reach inside the control compartment and release the retaining nut in the upper right corner. The nut should only be finger-tight.
17. When the conduit is pulled away from the jacket, pull the two brown wires out of the control compartment. Coil the conduit and wires on top of the heat exchanger.
18. Use a chassis punch to put two 7/8 inch (22 mm) holes in the front left side of the jacket (see Figure 19).
19. Remove the front and rear tile covers (see Figure 15).
20. Lift out the heat exchanger assembly, turn it 180 degrees, and reseat the unit in the heater with the water connections on the left side.
21. Reinstall the front and rear tile covers.
22. Push the capillary tube(s) out through the lower hole in the left side of the jacket.
23. Install the sensing bulb(s) into the appropriate temperature control (keep in mind that the positions of the inlet and outlet have been reversed. The inlet is now behind the outlet).

24. Fasten the capillary tube(s) by squeezing the retaining clip together, then tighten the screw.
25. Feed the two brown wires through the top hole on the left side until the conduit elbow is against the jacket.
26. Fasten the conduit by sliding the retaining nut over the two brown wires (inside the control compartment) then screwing it down finger-tight on the conduit elbow.
27. Straighten the capillary tubing and fasten it to the side of the heater under the channel. Use the self-tapping screws to fasten the channel to the jacket.
28. Feed the two white wires into the control compartment. Attach one wire to the terminal in the manual reset hi-limit switch. If one is not installed, attach it to terminal No. 1. Connect the other wire to the red wire attached to the fuse holder.
29. Attach the two brown wires to terminals No. 5 and 6 on the terminal strip. Keep all wiring away from surfaces that will get hot during heater operation.
30. Replace the gap closures and tighten the screws securely.
31. Replace the three grommets and the cap.
32. Reinstall the drain plug and drain valves.
33. Slip the flue collector assembly back down inside the enclosure.
34. Carefully slip a hand inside to make sure there are no gaps between the heat exchanger and the flue collector.
35. Check to make sure the wiring is not pinched against sharp edges, or resting on the collector assembly.
36. Replace the two flue collector holddown clamps.
37. Replace the top assembly and fasten it with the hex-head screws.
38. Replace the front cover.
39. Reinstall the vent cap or draft hood if one was removed.
40. On indoor installations (sizes 175-250), insert the draft hood switch plug into the receptacle on the left side of the heater.

2.6.2 Water Chemistry

Bradford White equipment is designed to be used in a variety of water conditions. With the proper pump, the water velocity in the heat exchanger tubes is kept high enough to prevent scaling from hard water, yet low enough to avoid erosion by soft water.

NOTE: It is possible to have hard and soft water in the same city. Check with the local water companies.

If an installer sees damage to any water handling equipment at the installation site, it should be repaired as soon as possible to help reduce maintenance costs. If there is erosion, resize the pump to reduce water velocity before the tube ruptures. If scaling is bad, set up a heat exchanger tube-cleaning maintenance schedule to prevent heat exchanger tube cracking and wear. Not fixing the condition will mean serious damage to the heater and the water system.

NOTES:

- In areas where the water supply is soft or corrosive, the heater must have cupronickel tubes in the heat exchanger.
- Bradford White does not warrant heat exchangers damaged by scaling, corrosion, or erosion.

2.6.3 Freeze Protection

Although Copper Brute heaters are design certified for outdoor installations, such installations are not recommended in areas subject to freezing temperatures unless proper precautions are taken. Consult the local factory representative or Bradford White for additional information.

2.6.4 Water Hardness

Consider the water hardness when selecting a pump for the heater (see Table 3). Hard water needs a pump which can provide high flow to prevent scaling, while soft water needs low flow to prevent erosion.

2.6.5 Pump Requirements

The Copper Brute heater has a factory installed pump which is for heater-to-tank circulation only. Pump performance is shown in Table 4.

The pump that is mounted on the heater is sized for the heat exchanger and 30 feet (9.1m) of 1-1/2" pipe, including six (6) 90° elbows. If more piping is needed, contact Bradford White for options.

The water temperature entering the Copper Brute must be at least 110°F (43°C).

Figures 20, 21 and 22 show typical piping arrangements. For assistance with other piping methods, contact Bradford White.

Hardness Category	Grains per Gallon	Parts per Million
Soft	1 through 7.5	17 through 128
Normal	7.6 through 17	129 through 291
Hard	Over 17	Over 291

Table 3. Water Hardness.

Model	Heat Exch. Passes	Water Category	Flow Rate		Pressure* Drop		Water Temp Rise	
			gpm	L/s	ft.	m	°F	°C
175	2	Soft	22	1.4	5.8	1.8	13	7
		Normal	34	2.1	11.2	3.4	8	4
		Hard	46	2.9	19.1	5.8	6	3
	4	Soft	11	0.7	4.9	1.5	25	14
		Normal	17	1.1	9.3	2.8	16	9
		Hard	23	1.5	15.9	4.8	12	7
250	2	Soft	22	1.4	5.8	1.8	18	10
		Normal	34	2.1	11.2	3.4	12	7
		Hard	46	2.9	19.1	5.8	9	5
	4	Soft	11	0.7	4.9	1.5	35	19
		Normal	17	1.1	9.3	2.8	33	18
		Hard	23	1.5	15.9	4.8	17	9
325	2	Soft	34	2.1	12.5	3.8	18	10
		Normal	34	2.1	12.5	3.8	18	10
		Hard	46	2.9	21.7	6.6	11	6
	4	Soft	17	0.7	10.4	3.2	36	20
		Normal	17	0.7	10.4	3.2	30	17
		Hard	23	1.5	18.1	5.5	22	12
400	2	Soft	34	2.1	13.3	4.1	19	11
		Normal	34	2.1	13.3	4.1	19	11
		Hard	46	2.9	23.4	7.1	14	8
	4	Soft	17	0.7	11.1	3.4	37	21
		Normal	17	0.7	11.1	3.4	37	21
		Hard	23	1.5	19.5	5.9	27	15

*Pressure drop includes head loss of heat exchanger and through 30 feet (9.1 m) of pipe and normal fittings when heater is installed with storage tank. Pipe and fittings are assumed to be 1-1/2 inch (38 mm).

Table 4. Pump Performance Requirements.

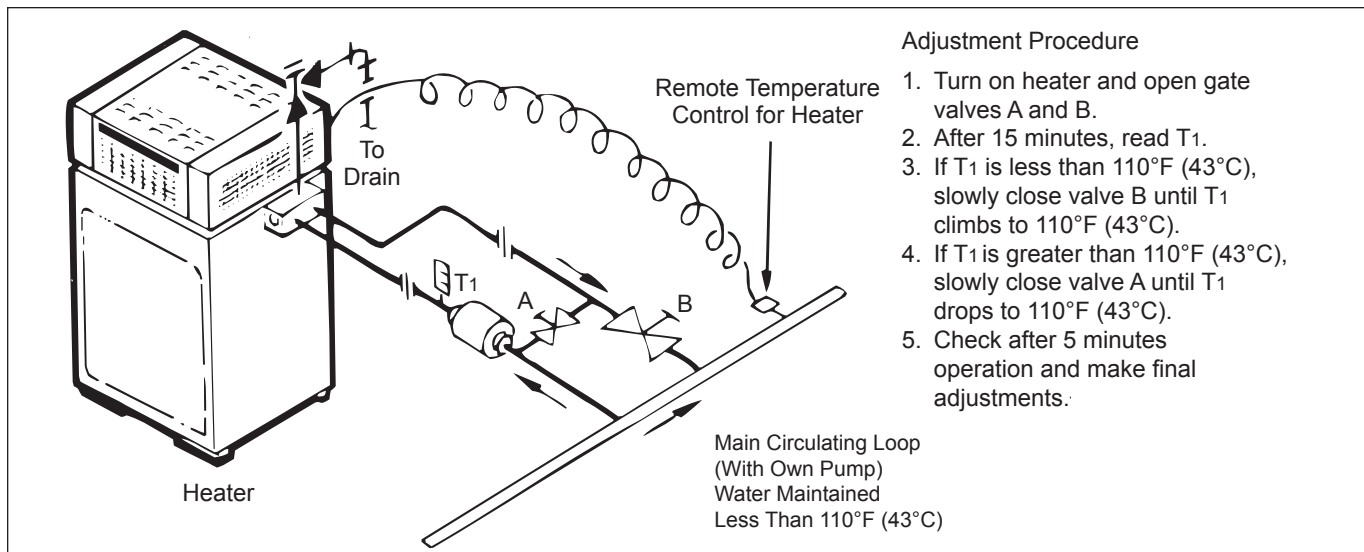

Figure 20. Cold water application.

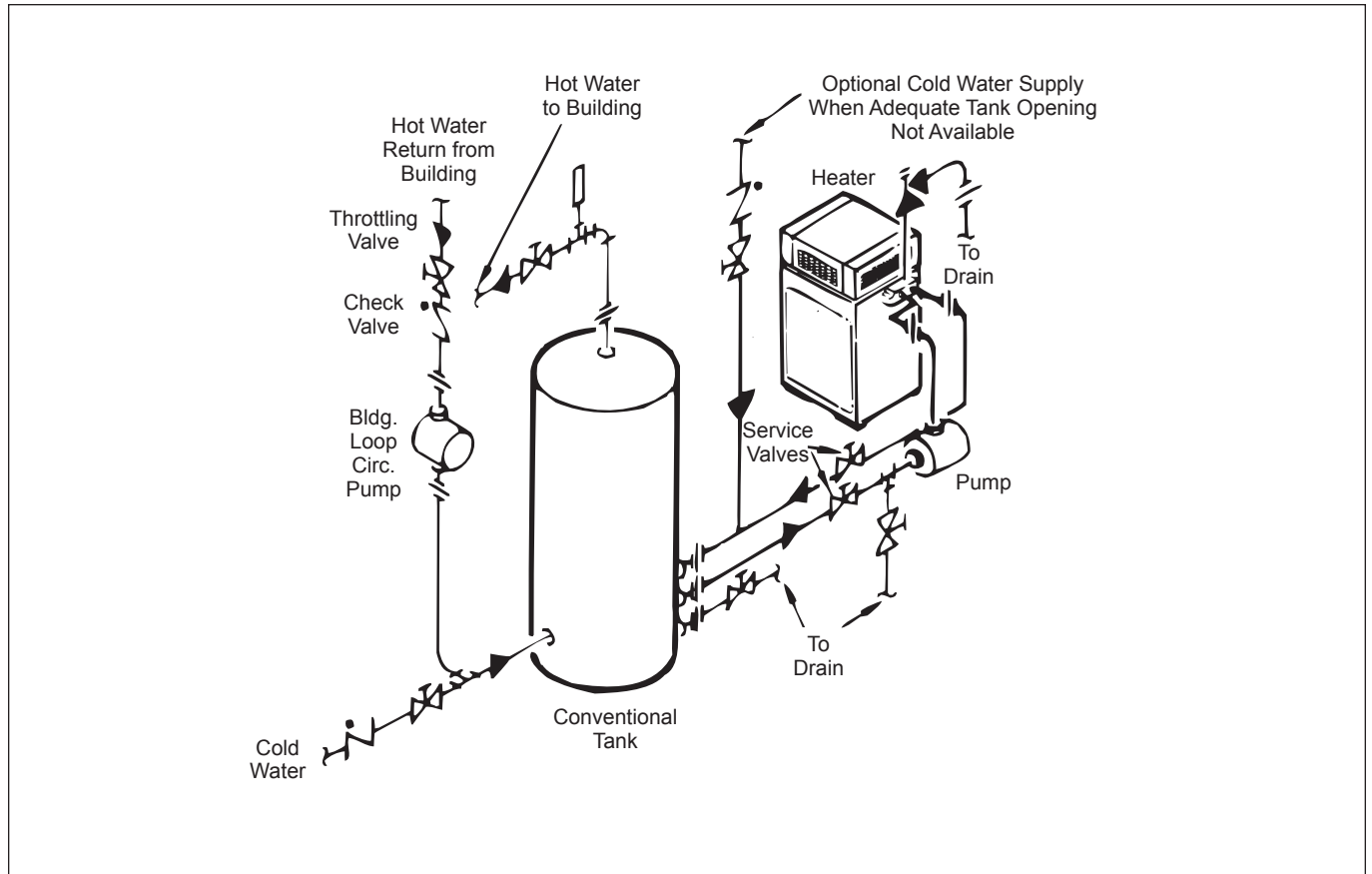

Figure 21. Hot water supply with vertical tank.

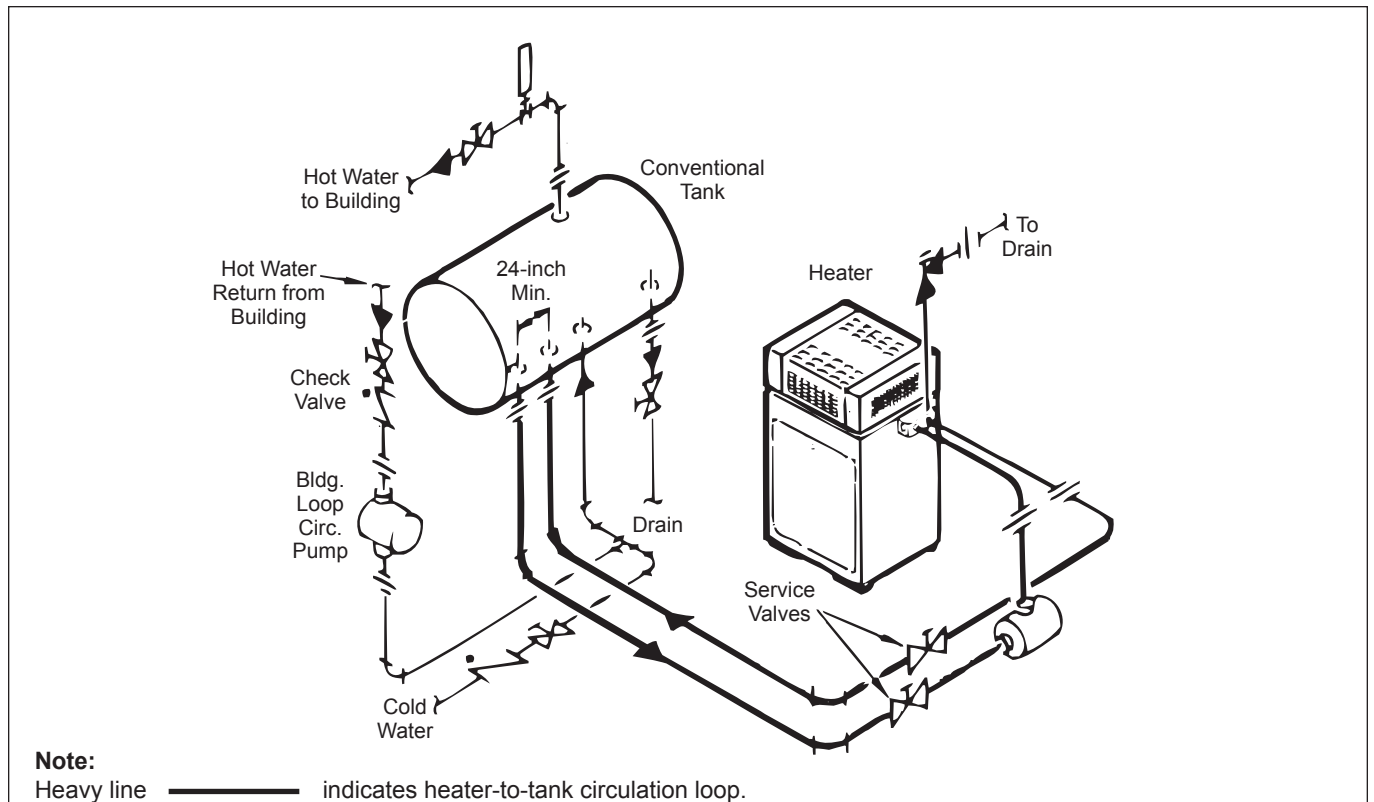

Figure 22. Hot water supply with horizontal tank.

2.6.6 Pressure Buildup in Water System

The water utility supply meter may contain a check valve, back flow preventer, or water pressure reducing valve that will create a closed water supply system. Contact the water supplier or local plumbing inspector on how to control this situation.

During the heating cycle of the heater, the water expands creating a pressure buildup in the water system. The pressure relief valve may discharge hot water under these conditions, causing a loss/waste of energy and a buildup of lime on the relief valve seat.

NOTE: Do not plug the relief valve.

There are two methods to prevent the relief valve from discharging hot water in a closed water system:

1. Install a pressure relief valve on the cold water supply line. Make sure that the discharge of this valve is directed to an open drain and protected from freezing.
2. Install a properly sized thermal expansion tank on the cold water supply line.

2.6.7 Pressure Relief Valve

The pressure relief valve must be installed in the tapped opening provided in the boiler header with its outlet piped to a drain or floor sink. Special attention must be given to relief valve settings in installations where the boiler is located on the ground floor of a tall building, or where the operating temperature of the boiler is above 210°F. In both instances, the static pressure of the system is elevated, and could cause the relief valve to leak. Where no special setting of the relief valve is ordered, the factory will furnish a 125 psi setting.

⚠ WARNING

Hot water can scald! Hot water can produce third degree burns in 6 seconds at 140°F (60°C) and in 30 seconds at 130°F (54°C).

2.6.8 Water Pressure

Keep the water pressure in the system above 30 psi (207 kPa). If the system pressure drops below 30 psi (207 kPa), it could damage the heater through lack of circulation. If for any reason, the water is turned off temporarily, to service the equipment for example, airlock could be a problem when the heater is turned back on. To eliminate the airlock, open the pressure relief valve (see Figure 23) and allow the air to bleed out until water starts to flow. As soon as full circulation is restored, the trapped air will be released through the hot water faucets.

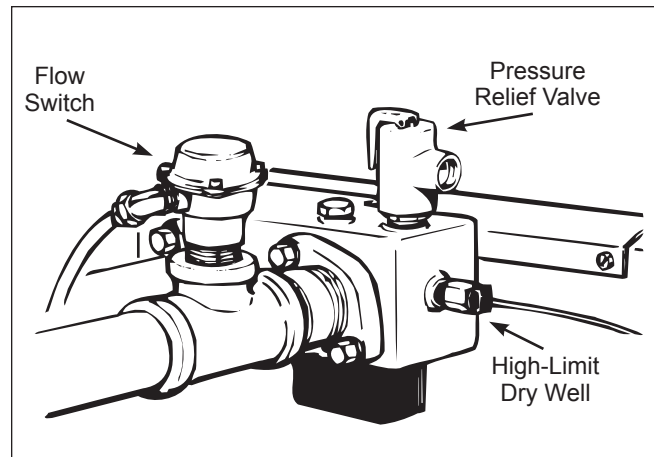

Figure 23. Pressure relief valve.

2.6.9 Storage Tank Installation

1. Be sure the floor is structurally capable of supporting the tank when it is filled with water, and is waterproof.
2. Place the tank so that manholes, inspection covers, nameplates and drain valves are accessible.
3. Be sure the tank is suitable for the water in the system. Some water is corrosive and requires a protected tank. Most tanks are available with glass, plastic, or galvanized linings.
4. If the tank is glass-lined, it should be equipped with a suitable magnesium anode. It is a good practice to replace the anode when it is approximately 50 percent used. The factory warranty on a glass-lined tank may be void if a satisfactory anode is not in place at the time of a failure or if it is consumed by cathodic action.
5. The tank must be lined if a water softener is installed in the system.
6. Make sure the tank connections in the heater-tank circulating loop are the proper size (see Section 2.6.5). If tappings are smaller than the recommended pipe size, a larger pump may be required. Consult the factory if in doubt.
7. Install a pipe in the tank drain fitting that goes to a floor sink, and install a drain valve. If a floor sink is not available, install a hose bib.
8. Hot water tanks in an existing installation are likely to have silt deposits on the bottom. Therefore, it is important to extend the pump suction pipe in the tank to a position near the top. Pipe the return from the heater to the bottom of the tank.

Incorrect installation can cause rapid failure of water tanks due to electrolysis. Tanks must be installed with dielectric connections to electrically isolate the tank from stray current. Note that use of brass or bronze connectors does not replace the need for dielectric connections.

2.6.10 Thermal Circulation of Hot Water in Cold Water Supply Lines

Under certain circumstances, thermal circulation will occur in the cold water pipe supplying the water to the heating system. This happens in a multi-story building when the cold water pipe rises from its connection to the system. To correct the problem, a check valve in the cold water line supplying the heater will prevent thermal circulation, and a small expansion tank will permit heated water to expand without popping off the relief valve.

2.7 Gas Supply and Piping

2.7.1 General Instructions

Review the following instructions before continuing the installation.

- Gas piping installation must be in accordance with the latest edition of ANSI Z223.1. In Canada, the installation must be in accordance with CAN1-B149.1 or .2 and all local codes that apply.
- Check the rating plate to make sure the heater is fitted for the type of gas being used. Bradford White heaters are normally equipped to operate below a 2000 foot (609 m) altitude. Heaters equipped to operate at higher altitudes have appropriate stickers or tags attached.
- If a gas pressure regulator is required, the installation must be in accordance with the latest edition of ANSI Z223. In Canada, the installation must be in accordance with CAN1-B149.1 or .2 and all local codes that apply.
- The figures in Table 5 should be used to size the gas piping from the gas meter to the heater.
- Install a sediment trap (drip leg) ahead of the gas controls (see Figure 24). Fit the trap with a threaded cap which can be removed for cleaning.
- Install a manual gas shutoff valve for service and safety. Check the local codes.
- Disconnect the heater and its individual shutoff valve from the supply gas system during pressure test of the system at pressures higher than 1/2 psi (3.4 kPa).
- Gas supply pressures to the heater are listed in Table 6.

NOTE: The heater and all other gas appliances sharing the heater gas supply line must be firing at maximum capacity to properly measure the inlet supply pressure. Low gas pressure could indicate an under-sized gas meter and/or obstructed gas supply line.

Distance from Gas Meter or Last Stage Regulator						
Boiler Size	0-100 feet 0-30 m		100-200 feet 30-60 m		200-300 feet 60-90 m	
	Nat.		Nat.		Nat.	
	in.	mm	in.	mm	in.	mm
175	1	25	1¼	32	1¼	32
250	1¼	32	1¼	32	1½	38
325	1¼	32	1½	38	1½	38
400	1¼	32	1½	38	2	51

Notes:

- These numbers are for natural gas (0.65 Sp. Gr.) and are based on ½ inch (13mm) water column pressure drop. Check supply pressure with a manometer, and local code requirements for variations. For liquefied petroleum gas, reduce pipe diameter one size, but maintain a ½ inch (13mm) minimum diameter.
- Check supply pressure and local code requirements before proceeding with work.
- Pipe fittings must be considered when determining gas pipe sizing.
- For propane gas: Reduce pipe diameter one size, but maintain a ¾ inch (19mm) minimum diameter.

Table 5. Natural Gas and Propane, Pipe Size Requirements.

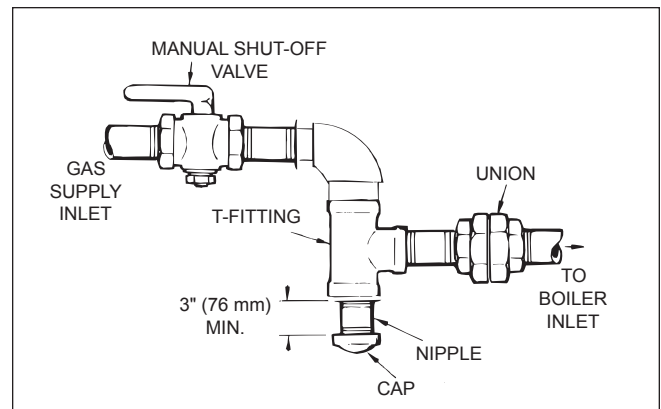

Figure 24. T-Fitting and sediment trap.

Supply Pressure Water Column	Natural Gas		Propane Gas	
	in.	mm	in.	mm
Minimum	6.5	165	11	279
	See Rating Plate			
Maximum	9	229	14	356

Table 6. Gas Supply Pressure Requirements.

- Do not exceed the maximum inlet gas pressures specified. Excessive pressure will result in damage to the heater's gas controls. The minimum pressures specified is for gas input adjustment.
- The correct burner manifold gas pressure is stamped on the rating plate. The regulator on the gas valve is preset at the factory, and does not normally need adjustment.

- Before operating the heater, test the complete gas supply system and all connections for leaks using a soap solution.

⚠ Caution

Since some leak test solutions (including soap and water) may cause corrosion or stress cracking, rinse the piping with water after testing.

2.7.2 Special Precautions for Propane Gas

Liquefied petroleum (LP) gas is heavier than air. Therefore, do not install heaters using LP gas in a pit or locations where gas might collect. Locate heaters a safe distance from LP gas storage and filling equipment. Consult local codes and fire protection authorities about specific installation restrictions.

2.8 Electrical Wiring

⚠ WARNING

Electrically ground the heater in accordance with the latest edition of the National Electrical Code, ANSI/NFPA 70. In Canada, use C22.1. Do not rely on the gas or water piping to ground the metal parts of the heater. Often, plastic pipe or dielectric unions isolate the heater electrically. Service and maintenance personnel who work on or around the heater may be standing on wet floors and could be electrocuted by an underground heater.

- Check heater wiring and pump for correct voltage, frequency, and phase. Check to make sure heater is wired for 120 volts alternating current (VAC). If 240 VAC, contact local factory representative or Bradford White.
- Wire the heater and pump exactly as shown in the wiring diagram supplied with the heater. See Figure 26 and 27 for a typical example of a wiring diagram.
- Electrically interlock the pump and heater so the heater cannot come on unless the pump is running.
- Connect all field-installed devices (draft switches, relays, timers, outdoor temperature reset devices, etc.) to the heater wiring at points labeled Field Interlock (see Figures 26, 27, 28 and 29).

2.9 Combined Space Heating/Potable Water Heating Systems

2.9.1 Combined Space Heating

NOTE: These systems are not allowed in the Commonwealth of Massachusetts.

Piping and components connected to this water heater for the space heating application shall be suitable for use with potable water.

Toxic chemicals, such as used for boiler treatment, shall not be introduced into the potable water used for space heating. Do not use solder containing lead in the potable water lines.

This water heater when used to supply potable water shall not be connected to any heating system or component(s) previously used with a non-potable water heating appliance.

When the system requires water for heating at temperatures higher than required for other uses, an anti-scald mixing or tempering valve (see Figure 25) shall be installed to temper the water for those uses in order to reduce scald hazard potential. Some jurisdictions may require a backflow preventer in the cold water line. In such cases, the temperature and pressure relief valve may discharge water due to expansion. A diaphragm type expansion tank will normally eliminate this condition. Follow the manufacturer's instructions for installation of the expansion tank.

SECTION 3. Operating Instructions

3.1 Normal Operating Sequence

NOTE: Safe lighting and other performance criteria were met with the gas manifold and control assembly installed on the heater during tests specified in ANSI Z21.13.

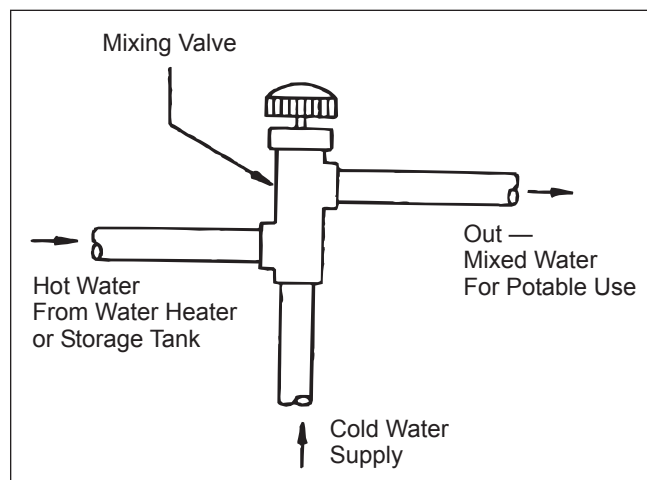

Figure 25. Installation of tempering valve.

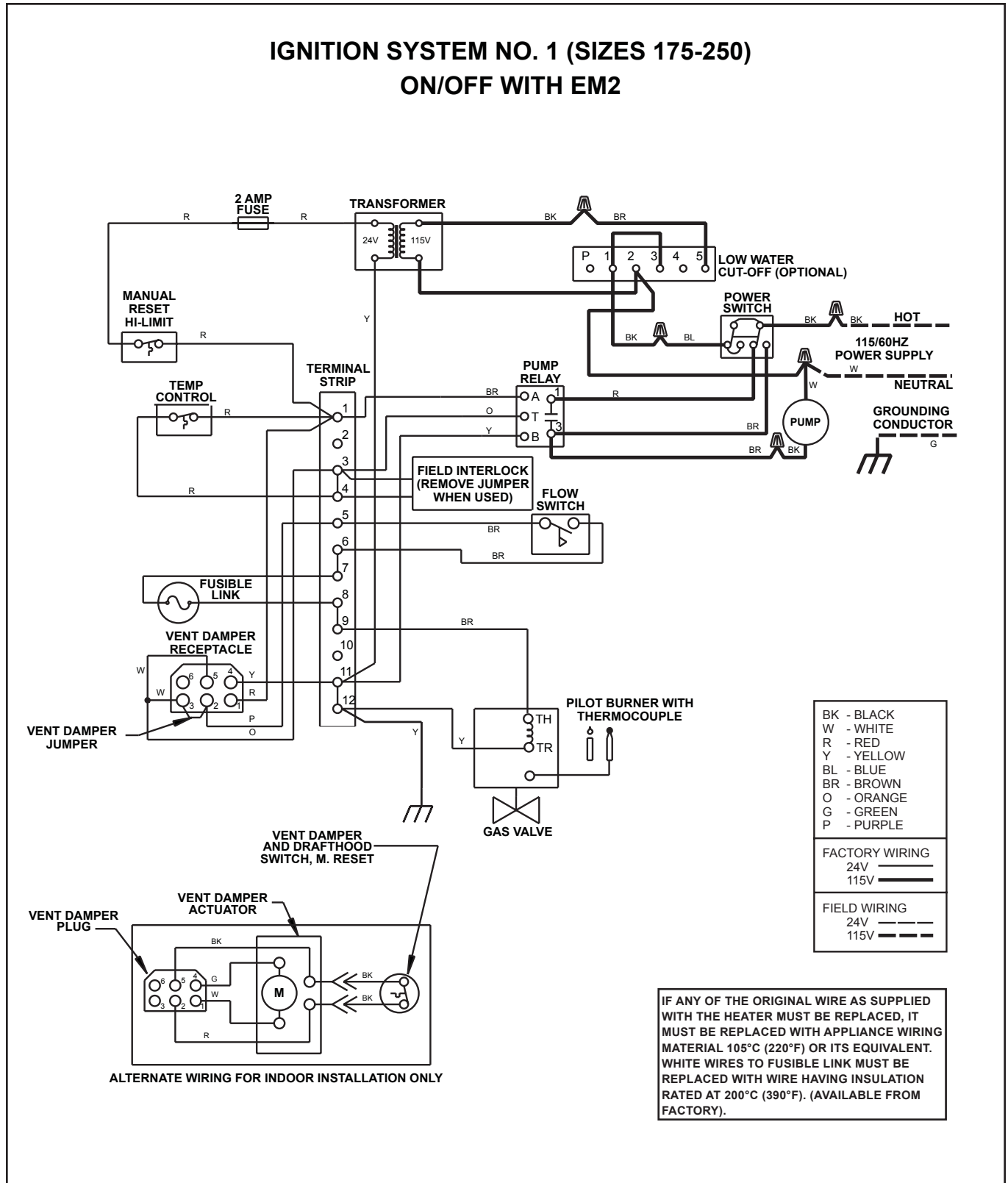
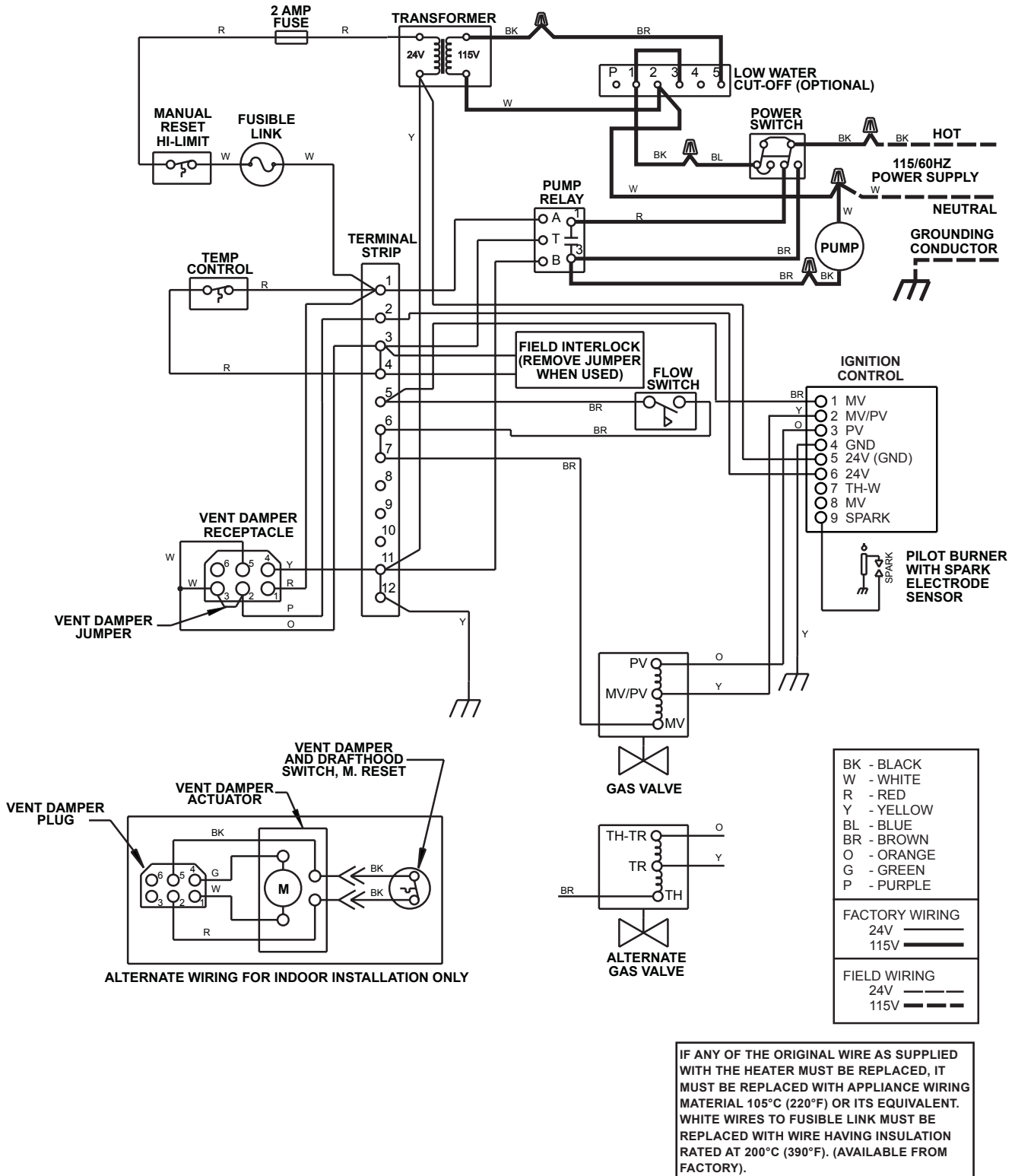

Figure 26. Typical example of wiring schematic, System 1, Sizes 175-250.

IGNITION SYSTEM NO. 12 (SIZES 175-250) ON/OFF WITH EM2



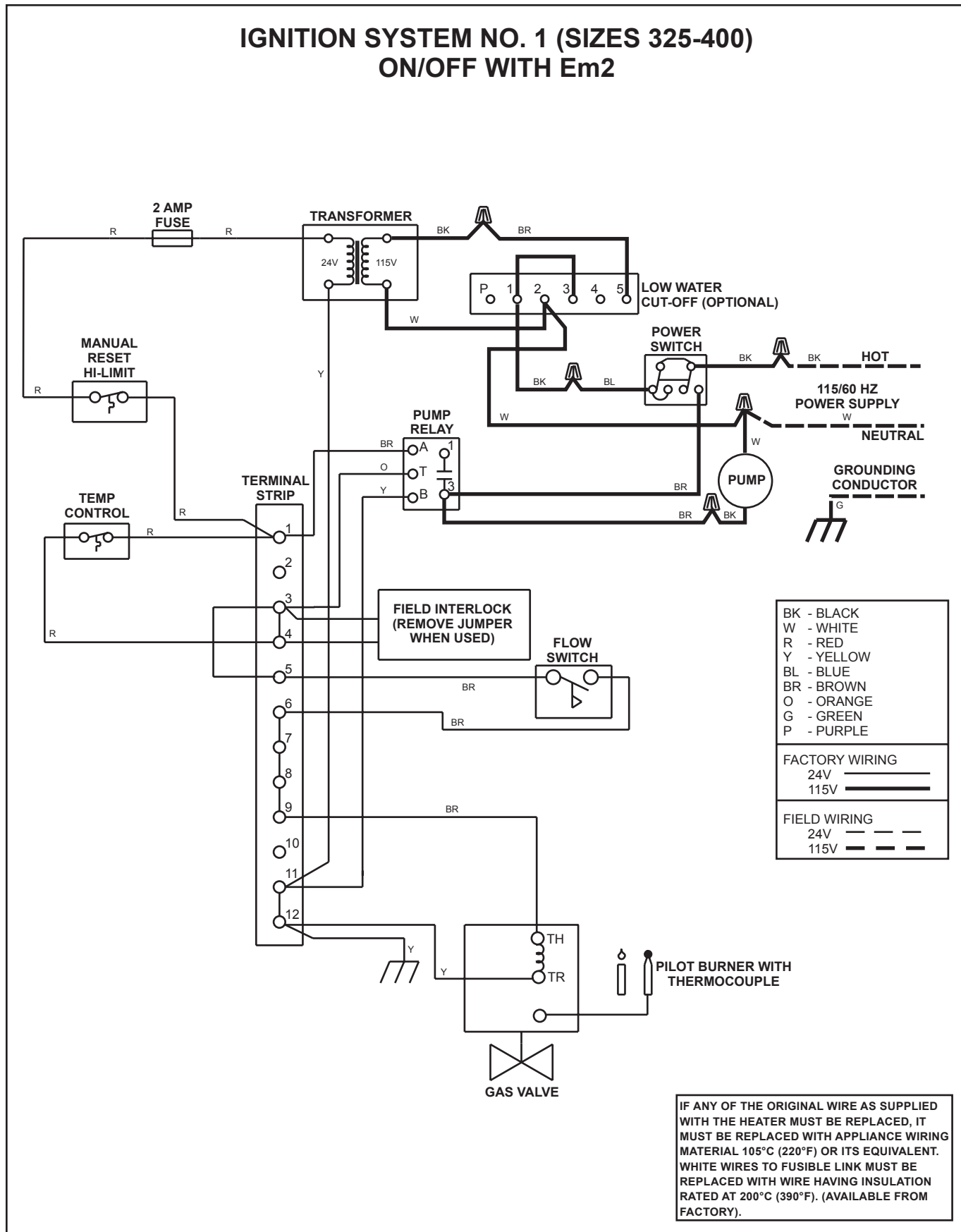

Figure 28. Typical example of wiring schematic, System 1, Sizes 325-400

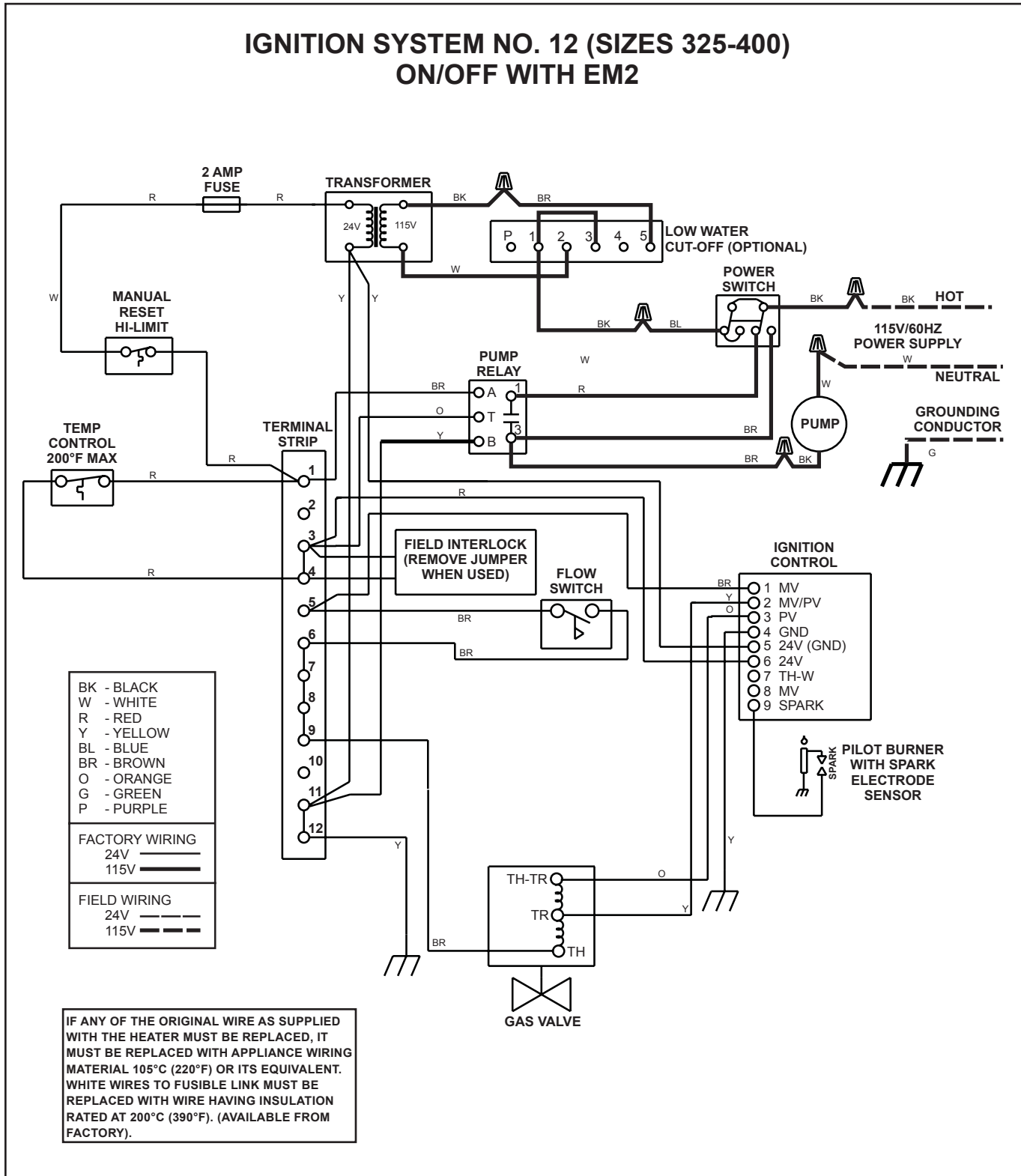

Figure 29. Typical example of wiring schematic, System 12, Sizes 325-400.

⚠ WARNINGS

Vent pipes, drafthoods, and heater tops get hot! These surfaces can cause serious burns. Do not touch these surfaces while the heater is in operation. Adding a vent cap reduces the temperature on the top.

For your safety, when starting the heater, keep your head and face well away from the lower firebox opening to prevent any risk of personal injury.

LP GAS: To avoid possible injury, fire and explosion, read and follow these precautions and all instructions on this heater before lighting. This heater uses LP gas which is heavier than air and will remain at ground level if there is a leak. Before lighting, sniff at ground level.

If you smell gas, follow these rules:

1. DO NOT light matches. DO NOT turn electric lights or switches on or off in area. DO NOT use an electric fan to remove the gas from area.
2. Shut off gas at LP tank.
3. Telephone gas company and fire department for instructions. Give your name, address and phone number.

If your LP tank runs out of fuel, turn off gas at the heater. After the tank is refilled, the heater must be relit in accordance with the instructions found on the inside of the heater. DO NOT attempt repairs on the gas control or heater. Tampering is dangerous and voids all warranties.

3.2 Start-Up Procedure

Lighting instructions can be found on the inside of the heater. To start up the heater:

1. Make sure the system pump is running and there is water flow.
2. Remove the control access panel.
3. Set the temperature control (see Figure 30) to its lowest setting.
4. Turn electric power to the appliance to off.
5. Turn manual gas valve off.
6. Wait 5 minutes to clear out any gas, then smell for gas, including near the floor. Be sure to smell next to the floor because some types of gas are heavier than air and will settle on the floor.

⚠ Caution

This heater is equipped with an ignition device which automatically lights the burner. Do not try to light the burner by hand.

7. Turn manual gas valve on.
8. Reset all safety devices (some units have manual resets on hi-limit switch, low water cutoff, etc.).
9. Set temperature control to desired setting.
10. Replace control access panel.
11. Turn electric power to the heater on.
12. If the heater will not operate:
 - a. Turn gas to heater off following the instructions found on the inside of the heater and call a qualified service technician or gas supplier.
 - b. Turn main electrical switch off.
 - c. Close all manual gas valves.

3.3 Setting the Temperature Controls

The hi-limit switch is factory set, and should not be adjusted above the factory setting.

⚠ WARNING

Adjusting the temperature control past the recommended setting can result in a scalding injury. Hot water can produce third degree burns in 6 seconds at 140°F (60°C) and in 30 seconds at 130°F (54°C).

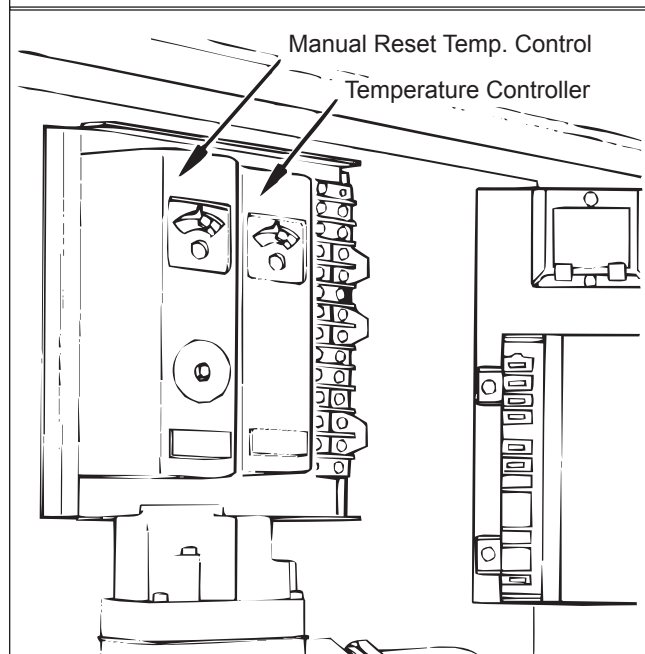

Figure 30. Temperature controls.

3.3.1. Remote Water Heater Temperature Control:

The water heater can be used with a field-supplied tank aquastat, sequencing control, or other temperature control device, which will call the unit for heat when the temperature goes below the controller's setpoint. For the most efficient setting, set the tank temperature at the lowest possible setting for adequate hot water in the application.

After a setting has been chosen for the tank temperature control, set the heater temperature control 10°F (6°C) higher. The heater's temperature control senses the inlet water temperature to the heater. The heater's manual reset high limit (and automatic reset high limit, if applicable) senses heater outlet temperature.

If the unit is equipped with an automatic reset high limit, set the automatic reset high limit 20°F (11°C) above the outlet temperature to avoid nuisance lockouts. Set the manual reset high limit 5°F (3°C) above the automatic reset high limit.

For units that only have a manual reset high limit (no automatic reset high limit), set the manual reset high limit 20°F (11°C) above the outlet temperature to avoid nuisance lockouts.

Example, Imperial units: If the tank temperature is set to 140°F, set the heater's temperature control to 150°F (140°F + 10°F). Further, if the temperature rise through the heater is 25°F, the outlet temperature will be 175°F (150°F + 25°F). Therefore, set the automatic reset high limit to 195°F (170°F + 20°F), and the manual reset high limit to 200°F (195°F + 5°F).

Example, Metric units: If the tank temperature is set to 60°C, set the heater's temperature control to 66°C (60°C + 6°C). Further, if the temperature rise through the heater is 15°C, the outlet temperature will be 81°C (66°C + 15°C). Therefore, set the automatic reset high limit to 92°C (81°C + 11°C), and the manual reset high limit to 95°C (92°C + 3°C).

3.3.2. Internal Water Heater Temperature Control:

When an external control is not used, the circulator between the heater and the storage tank must run continuously, so that the heater's temperature control can detect and control the water temperature in the storage tank. The water heater's temperature control is adjusted to its lowest temperature position (130°F, 54°C) when shipped from the factory. This is the preferred starting point for setting the temperature control.

If the unit is equipped with an automatic reset high limit, set the automatic reset high limit 20°F (11°C) above the outlet temperature to avoid nuisance lockouts. Set the manual reset high limit 5°F (3°C) above the automatic reset high limit.

For units that only have a manual reset high limit (no automatic reset high limit), set the manual reset high limit 20°F (11°C) above the outlet temperature to avoid nuisance lockouts.

Example, Imperial units: If the heater's temperature control is set to 130°F, and the temperature rise through the heater is 25°F, the outlet temperature will be 155°F (130°F + 25°F). Set the automatic reset high limit to 175°F (155°F + 20°F) and set the manual reset high limit to 180°F (175°F + 5°F).

Example, Metric units: If the heater's temperature control is set to 55°C, and the temperature rise through the heater is 14°C, the outlet temperature will be 69°C (55°C + 14°C). Set the automatic reset high limit to 80°C (69°C + 11°C) and set the manual reset high limit to 83°C (80°C + 3°C).

3.4 Adjustment for Minimum Input Rate (models with modulating gas valve)

Adjust the red knob on the modulating gas valve to the dial number for the desired water temperature (see Table 7). Adjusting the red knob to number "1" sets the gas flow rate to minimum. The control is factory set at "2" which is satisfactory for most installations.

Dial No.	Temp.	
	°F	°C
1	120	49
2	127	53
3	135	57
4	142	61
5	150	66
6	157	69
7	165	74
8	172	78
9	180	82

Table 7. Water Temperature Setting.

3.5 Hi-Limit Switch Checkout

After running the heater for a long enough period, bring the water temperature within the range of the hi-limit switch and slowly back off the high limit setting until the heater shuts off. The main burners should reignite when the hi-limit switch is reset and turned back up to its original setting. The heater should now run until it shuts off automatically on operating control.

Should overheating occur or the gas supply fail to shut off, turn off the manual gas control valve to the heater.

3.6 Shut-Down Procedure

Shut down the heater following the instructions found on the inside of the heater.

Where there is a danger of freezing, shut off the water supply and remove the drain plugs on both sides of the heater jacket. Drain every part of the system subject to damage from freezing temperatures.

SECTION 4. Maintenance

4.1 General Instructions

1. Oil the water circulating pump in accordance with the manufacturer's instructions.
2. If a strainer is used in a pressure reducing valve or in the piping, clean it every 6 months in accordance with the manufacturer's instructions.
3. At startup and every 6 months after, look at the pilot and main burner flame (see Figure 31). If the flame has the appearance of sooting tips, check for debris near orifices. Call service technician.
4. Inspect the venting system for blockage, leakage, and corrosion at least once a year.
5. Keep the heater area clear of combustible material, gasoline, and other flammable liquids and vapors.
6. Be sure all combustion air and ventilation openings are not blocked.
7. Check for black carbon soot buildup on the external surfaces of the heat exchanger every 6 months.
8. Do not use the heater if any part has been under water. Replace any part of the control system and any gas control which has been under water.

NOTE: After installation and first startup, check the heat exchanger for black carbon soot buildup after the following periods of operation: 24 hours, 7 days, 30 days, 90 days, and once every 6 months thereafter.

4.2 Replacement of Gas Controls

The gas and electric controls installed on the heaters are designed for both dependable operation and long life. Safe operation of the heater depends on their proper functioning.

NOTE: The warranty does not cover damage caused by lack of required maintenance or improper operating practices.

⚠ WARNING

Never attempt to repair the gas valve. Such attempts will void the warranty, and could lead to dangerous results.

If the gas valve is found to be defective, replace it by following these instructions.

1. Turn off electrical power to the heater.
2. Turn off the main gas supply at the manual gas cock outside the heater jacket or at the meter.

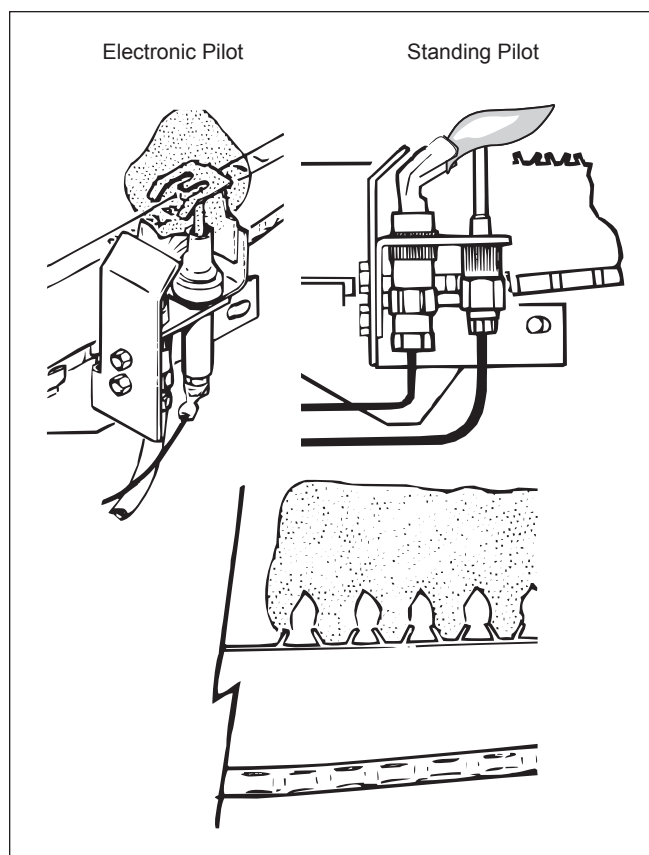

Figure 31. Flame patterns.

3. Remove the front access door on the heater.
4. Disconnect the service union in the gas line, and unscrew the main gas pipe from the gas valve (see Figure 32).
5. Remove the two screws that fastens the anti-rotation bracket on the left side of the gas valve (see Figure 32), and the three screws attached to heater.
6. Remove the pilot gas tube and copper thermocouple shield, if present, from the gas valve.

⚠ Caution

Label all wires prior to disconnection. Wiring errors can cause improper and dangerous operation.

7. Tag and remove all wires from the gas valve terminals.
8. Pull the burner tray out of the heater (see Figure 32).
9. Screw the new gas valve onto the manifold pipe. Make sure the arrow on the bottom of the gas valve that indicates the direction of gas flow is in the proper direction. Also make sure the brass fitting is on the right side.
10. Connect the pilot gas tube to the pilot assembly and thermocouple to the gas valve.

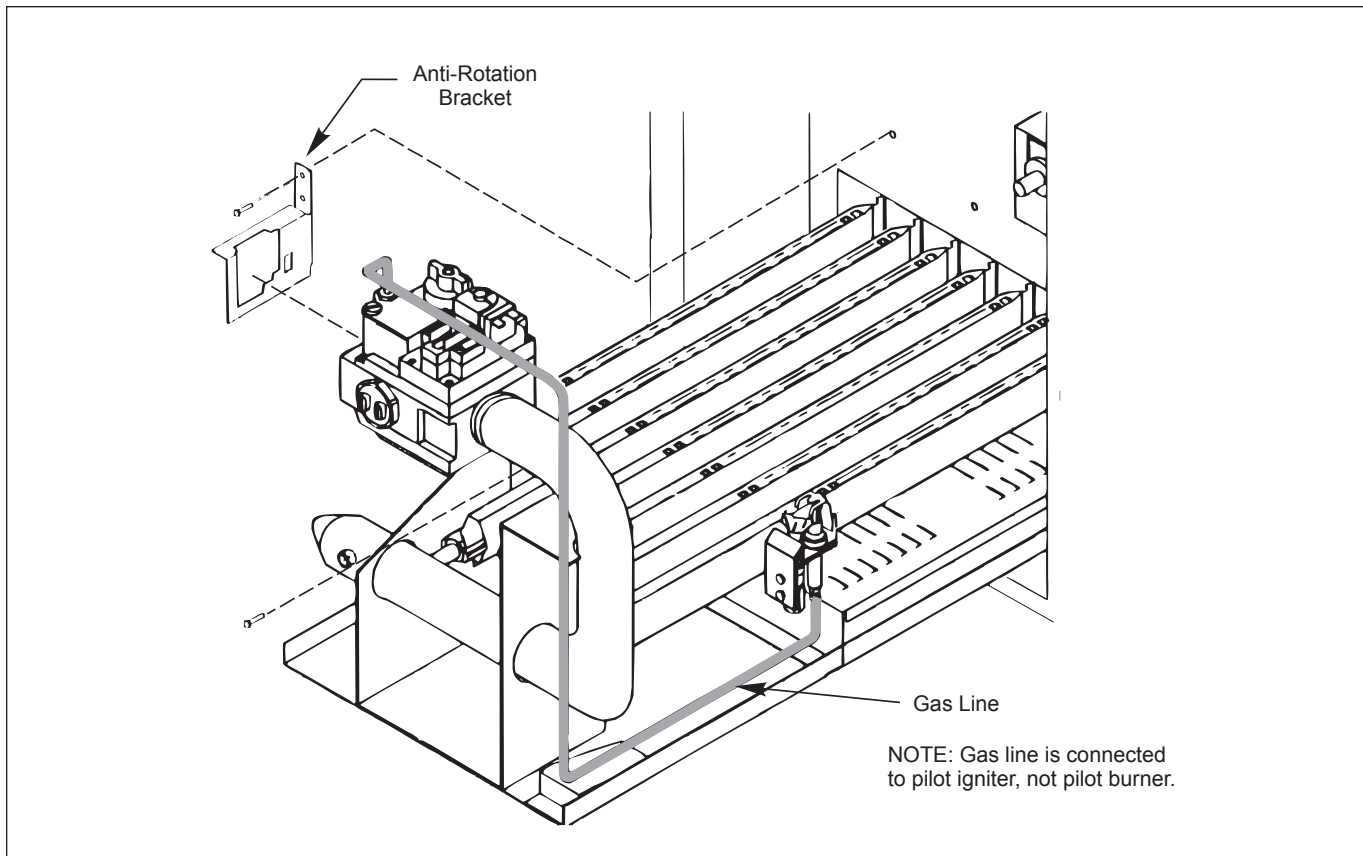

Figure 32. Gas valve/burner replacement.

NOTE: Due to sharp edges on the metal burners, wear protective gloves for the next steps.

11. Hold the gas burner or pilot burner firmly, and push it away from the manifold until it is clear of the orifice. Slide the burner to be replaced out of the burner tray (see Figure 33).
12. To replace the gas burner, insert the burner into the slot at the rear of the burner tray, line it up with the proper orifice and snap it into position.
13. To replace the pilot burner, install the pilot assembly on the new pilot burner and install it in the burner tray.
14. Slide the burner tray back into the heater and fasten it with two screws.
15. Install the anti-rotation bracket to the inner panel and fasten with two screws (see Figure 32), and the three screws to heater.
16. Connect the service union in the gas line, and screw the main gas pipe to the gas valve (see Figure 32).
17. Turn on gas valve following the lighting instructions found on the inside of the heater.
18. Turn on the main gas supply at the manual gas cock or the meter.
19. Check the system for leaks using a soap solution.

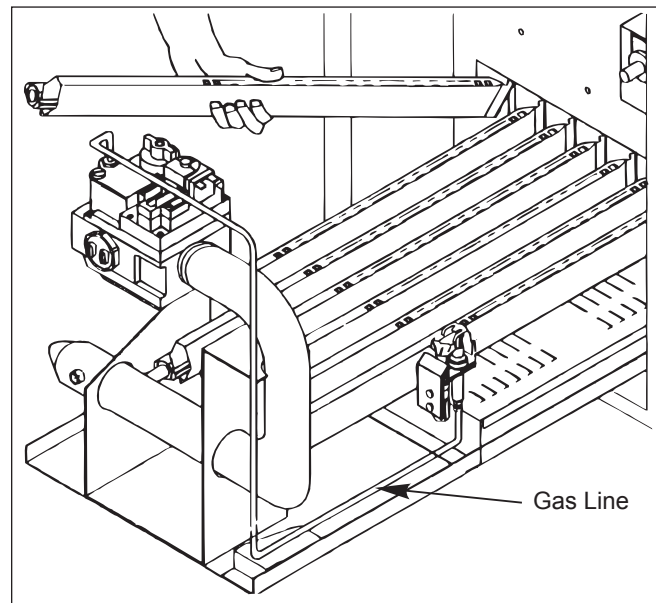

Figure 33. Burner removal.

⚠ Caution

Since some leak test solutions (including soap and water) may cause corrosion or stress cracking, rinse the piping with water after testing.

20. Reconnect the electrical wires to the gas valve in accordance with the wiring diagram found on the inside of the heater.

21. Install the front access door on the heater.
22. Turn all electrical power to the heater on.

4.3 HEAT EXCHANGER

4.3.1 Inspecting the Heat Exchanger

To check the scale buildup, periodically inspect the tube having the highest temperature as follows:

1. Open the drain valve on the left side of the heater.
2. Remove the hex-head plug located on the right side of the heater under the in/out header (see Figure 34). Perform this inspection after 60 days of and after 120 days of operation. This will establish a regular inspection routine.

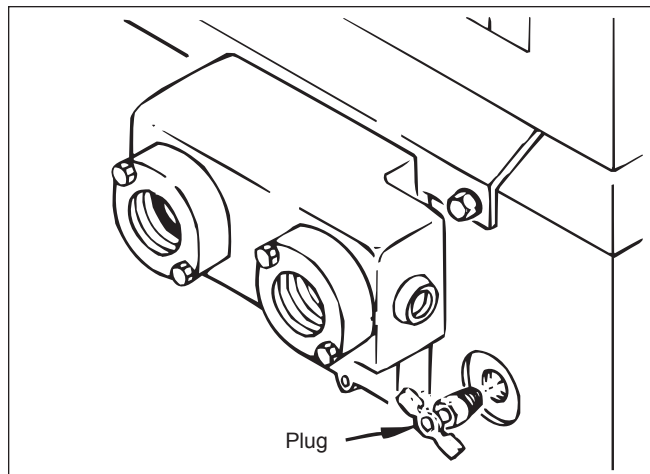

Figure 34. Scale inspection.

4.3.2 Cleaning the Heat Exchanger

An inspection and cleaning of the complete heat exchanger can only be done by removing it from the heater.

1. To remove the heat exchanger, refer to Section 2.6.1.

⚠ Caution

Black carbon soot buildup on a dirty heat exchanger can be ignited by a random spark or flame. To prevent this happening, dampen the soot deposits with a wet brush or fine water spray before servicing the heat exchanger.

2. Remove the heat baffles and check for a light accumulation of soot or corrosion on the outside of the heat exchanger tubes.

NOTE: While the heat exchanger is out of the heater, inspect the firewall refractory insulation blocks for cracks, wear, and breakage. Replace if necessary.

3. Use a wire brush to remove soot and loose scale from the heat exchanger. Do not use water or compressed air for cleaning.

NOTE: Use only the correct carbide tipped reamers which are available from Bradford White.

4. Ream the insides of the tubes (see Figure 35).
5. Pull the reamer out frequently to remove lime powder and prevent the drill from binding in the tube.
6. Install new gaskets. Do not reuse the old ones.
7. Tighten the header bolts progressively, starting with the two center bolts. Maximum torque is 20 inch pounds (27 Nm). Do not over-torque.

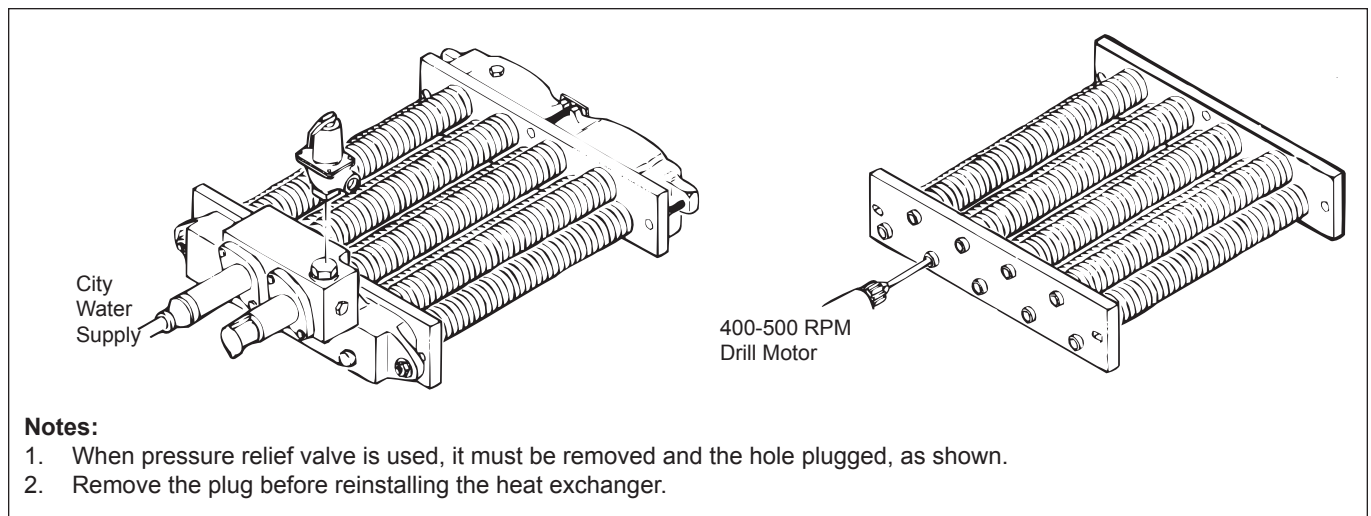

Notes:

1. When pressure relief valve is used, it must be removed and the hole plugged, as shown.
2. Remove the plug before reinstalling the heat exchanger.

Figure 35. Heat exchanger tube cleaning.

8. Pressure test the heat exchanger for leaks with city water supply before re-installing (see Figure 35).
 9. When placing the heat exchanger back in the heater, carefully hold the refractory insulation blocks apart and lower the heat exchanger into place. Be sure the sheet metal covers, which protect the insulation blocks, are replaced carefully.
 10. If a header bolt is stripped, drive it out of the header plate and replace it.
 11. To reinstall the heat exchanger, refer to Section 2.6.1.
4. Remove the 1/8 inch Allen Plug on the inlet side of the gas valve and replace it with the 1/8 inch (3.2 mm) NPT fitting from the manometer kit.
 5. Attach one end of the manometer hose to the fitting on the gas valve and the other end to the manometer.
 6. Open gas supply valve to the heater to test.
 7. With the main burners firing, the manometer reading should be between 6.5 and 9 inches W.C. for natural gas, and between 11 and 14 inches W.C. for propane units (see Table 6).

SECTION 5. Troubleshooting and Service

5.1 Gas Pressure Tests

Use the following procedures to check the main gas and manifold regulated gas pressures. A manometer or a dry gas pressure gauge may also be used for either test.

5.1.1 Checking the Main Line Gas Pressure

1. Attach a manometer (or a dry gas pressure gauge) to heater jacket (see Figure 36).
2. Open both columns on the manometer.
3. Use shutoff valve outside the heater jacket to shut off all gas supply to the heater.

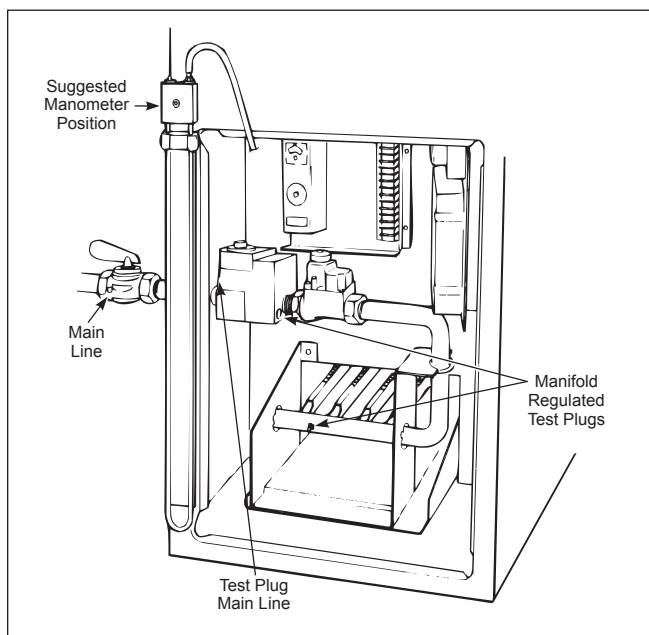

Figure 36. Gas pressure test.

5.1.2 Checking the Manifold Regulated Gas Pressure

1. Attach a manometer (or a dry gas pressure gauge) to heater jacket (see Figure 36).
2. Open both columns on the manometer.
3. Use shutoff valve, on outside of heater jacket, to shut off all gas supply to the heater.
4. Remove the 1/8 inch (3.2 mm) NPT test plug on the outlet side of the manifold, and replace it with the 1/8 inch (3.2 mm) NPT fitting from the manometer kit, (see Figure 36).
5. Attach one end of the manometer hose to the fitting on the manifold and the other end to the manometer.
6. Turn on gas supply to the heater, and set the temperature control high enough to call for heat.
7. Turn toggle switch to ON. This should activate the main burners.
8. The manometer reading should be 4 inches (102mm) W.C. for natural gas and 9 inches (229mm) W.C. for propane gas.
9. Turn the toggle switch to OFF.
10. Shut the system down following the instructions found on the inside of the heater.
11. Disconnect the manometer tubing from the manifold and replace the 1/8 inch (3.2 mm) NPT fitting with the original plug.

5.2 Electrical Troubleshooting

This section describes procedures for checking the electrical power and control components of the heater. Read all of these procedures before starting repairs.

Problems with heaters not firing are usually caused by something reducing water flow through the heater, causing the protective switches in the heater system to shut down the heater.

The following tools are required for proper service and problem diagnosis of the heater and heating system.

1. Gas pressure test kit with range from 0 to 14 inches (0 to 356 mm) W.C.
2. Electric meter(s) with the following ranges:
 - a. 0 to 500 volts VAC
 - b. 0 to 2000 ohms (Ω)
 - c. 0 to 20 microamps (mA)
 - d. 0 to 50 millivolts (mV)
3. A pressure gauge and a thermometer with proper ranges for heater operation.

5.2.1 Heater Does Not Come On

Important: Disconnect power to the heater or pull the RED wire off the transformer secondary before removing or replacing any component or wire connection.

⚠ WARNING

If power is not disconnected, jumpering gas valve or accidental grounding of the wire harness, or component terminals to the heater frame or jacket could cause the ignition control fuse to blow or may cause the heater to fire, resulting in injury or property damage.

1. Make sure the heater has been properly installed.
2. Make sure the pump is not airlocked, clogged or otherwise inoperative.
3. Make sure the gas valve is on and there is gas pressure in the line.
4. Check all electrical connections and wiring. Finding a loose connection or a charred wire can save a lot of time and money.
5. Check the fuse inside the black, twist-lock fuse holder. If it is burned, replace it with a 2-amp fuse (Part No. E0084400). If there is a short, the cause of the short must be found and repaired. Do not jumper or bypass the fuse.
6. Make sure the electrical circuit to the heater is on.
7. Make sure the toggle switch on the right side of the heater is on.
8. Make sure the temperature control is set high enough to call for heat.
9. Make sure the manual reset on the safety controls (e.g., low water cutoff, hi-limit switch, etc.) has not tripped. If it has, reset it.

If the pump is circulating water, and the rest of these items check out all right, the trouble could be in the heater control system.

⚠ Caution

Label all wires prior to disconnection when servicing controls. Wiring errors can cause improper and dangerous operation. Verify proper operation after servicing.

5.2.2 Testing the Transformer

NOTE: Keep the pump running.

Testing the transformer requires an AC voltmeter with a 50 volt (V) range. Test the transformer using the following procedures:

1. Clip a lead from the voltmeter to the yellow wire terminal on the transformer.
2. Touch the other lead to the red wire terminal (see Figure 37). The voltmeter should read 24 to 28VAC.
3. If the voltmeter does not show voltage, check the electrical power supply.
4. If the voltage is less than 20VAC, the electrical circuit to the heater may be supplying less than 103VAC. This could be due to high pump load or air conditioners or other appliances on the circuit.

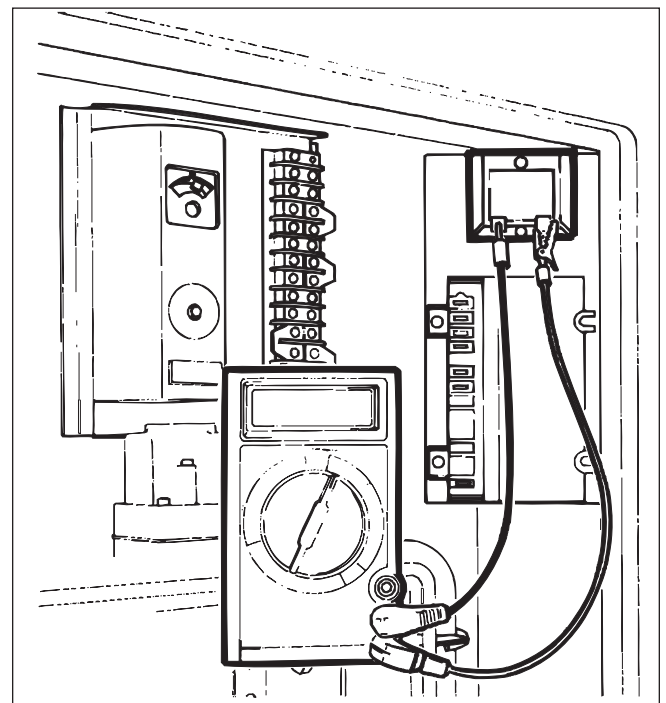

Figure 37. Testing the transformer.

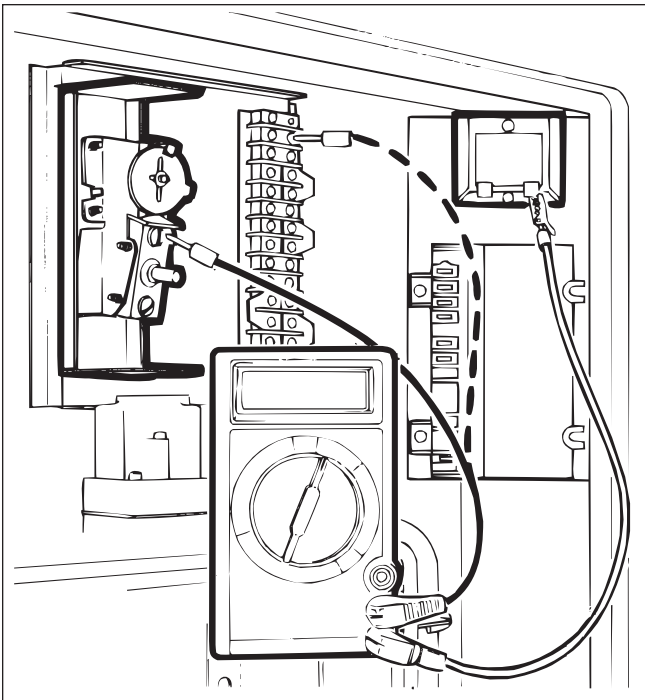

Figure 38. Testing the manual reset hi-limit switch.

5.2.3 Testing the Electrical Power Supply

The electrical components operate with supply voltage ranging from 103 to 126VAC at 60 Hertz (Hz). To test the electrical power supply:

1. Measure the voltage at the hot and neutral connections inside the heater electrical junction box.
2. Voltage outside of the required range may be due to poor wiring connections, to other loads (e.g., air conditioners, compressors) on the circuit, to high pump load, or to an electrical utility company problem.

5.2.4 Testing the Manual Reset Hi-Limit Switch

To test the manual reset hi-limit switch (see Figure 38):

1. Touch the other lead of the voltmeter to both terminals of the manual reset hi-limit switch. The voltmeter should read 24 to 28VAC at both terminals.
2. If no voltage is detected at one terminal, reset the manual reset hi-limit switch by pressing the reset button. Check the temperature setting.
3. If after pressing the reset button there is still no voltage indicated at one terminal, replace the manual reset hi-limit switch. An open switch may indicate excessive water temperatures or improper setting.

5.2.5 Testing the Flow Switch

The flow switch is a safety device that senses water flow through the heater. When the switch senses adequate water flow, it closes, allowing the heater to fire. If the water flow is too low, the switch remains open and prevents the heater from firing regardless of the temperature control setting.

The flow switch is factory mounted and wired. Never attempt to repair the flow switch. If the flow switch is found to be defective, replace the flow switch. To test the flow switch:

1. Remove cap from flow switch.
2. Touch a voltmeter lead to each terminal of the flow switch.
3. If the voltmeter reads voltage at each of the terminals, the switch is good.
4. If there is no voltage at one terminal, it indicates an open switch. Check flow switch paddles to determine if they are broken, missing or frozen. Replace the flow switch.

5.2.6 Testing the Fusible Link (flame roll-out switch)

The fusible link is a thermally fusible element which shuts down the heater if it detects excessive temperatures inside the heater flue collector compartment. To test the fusible link (flame roll-out switch, if installed):

1. Touch the voltmeter lead to the lower terminal on the terminal block (see Figure 39).

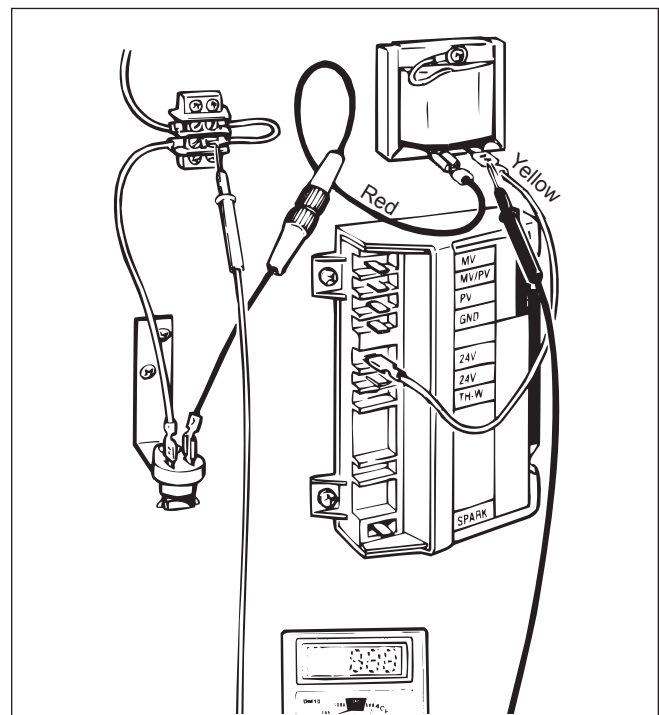

Figure 39. Testing the fusible link.

- If the voltmeter reads voltage, the safety fuse and the fusible link are good.
- Replace the fusible link when an open circuit is detected. An open fuse line indicates overheating in the flue collector or compartment.
- Check for leaks of the flue collector, vent pipe, gaskets, and all connections.
- Check the flue pipe for blockage.
- Check heat exchanger fins for partial sooting.

5.2.7 Testing the Fuse

To test the fuse:

- Clip a lead of the voltmeter to the grounding terminal.
- Touch the other voltmeter lead to the 24VAC terminal on the ignition control.
- If there is no voltage, replace the fuse. A blown fuse is usually an indication of a short in the 24VAC circuit. It is important that the cause of the short be found and repaired. Do not jumper or bypass the fuse.

5.2.8 Testing the Ignition Control (for spark ignition)

⚠ Caution

The ignition control and igniter operate on 120V power. Keep this in mind while servicing the heater, and take care to avoid electrical shock.

The ignition control provides power to the pilot, opens the gas valve when there is a call for heat, and senses when a flame is established. To test the ignition control for spark ignition:

- Clip one lead from the voltmeter to the yellow wire terminal on the transformer.
- Touch the other voltmeter lead to the red 24V terminal on the ignition control.
- If the voltmeter reads voltage, the temperature control and the manual reset hi-limit switch are not keeping the heater from firing.
- Make sure the pilot burner is positioned next to the main burner (see Figure 40) and there is no soot or dirt on it.
- Make sure the electrode (part of pilot assembly) is clean, the terminal connection is tight, and the ceramic insulator lead is at least 3/8 inch (9.5 mm) from the heater chassis and other metal parts.
- Check for proper spark gap.

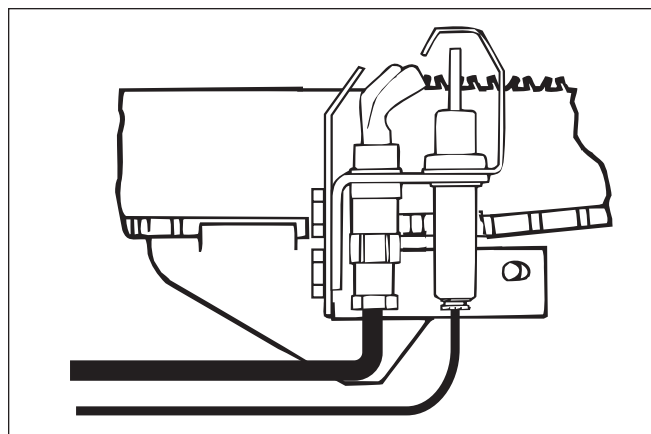

Figure 40. Pilot location (spark ignition).

5.2.9 Testing the High Voltage Ignition Lead

Connections must be tight, and silicone rubber boots in place. Bare metal parts at the base of the manifold bracket must be at least 3/8 inch (9.5 mm) from other metal objects. To test the ignition lead:

- Turn the control panel switch to on.
- Make sure the temperature control is turned far enough to call for heat. There will be a loud clicking noise indicating the pilot electrode is sparking.
- If no sparking is heard, pull the ignition lead from the ignition control and hold the bare terminal 1/8 to 3/16 inch (3.2 to 4.8 mm) from the ignition stud with a pair of insulated pliers (see Figure 41).
- If a spark does not jump the gap, replace the ignition control.

NOTE: The ignition control cannot be repaired in the field. If it does not operate properly, replace it.

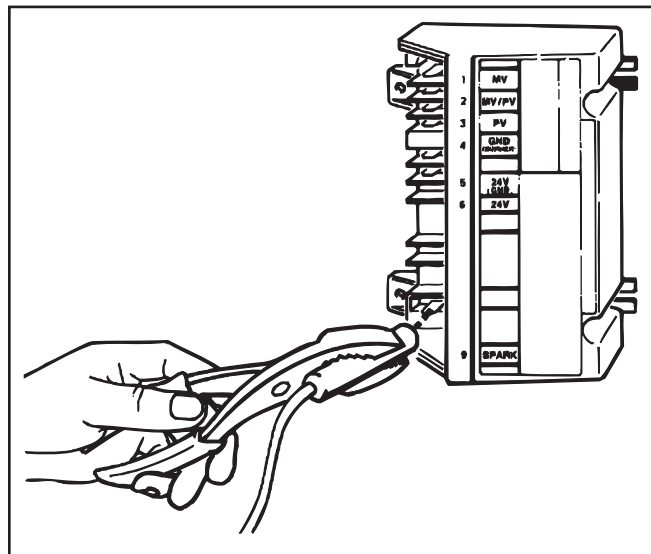

Figure 41. High voltage ignition test.

5.2.10 Testing the Safety Shutoff (for standing pilot)

After lighting the heater, test the ignition system safety shutoff.

1. With the main burners firing, turn the gas valve control knob off.
2. Turn power to the heater off.
3. Set the temperature control to its lowest setting.
4. Wait 5 minutes.

Caution

Flame Hazard. Failure to wait 5 minutes, or not turning the gas valve knob to OFF, may cause the flow of unlighted main burner gas.

5. Turn the gas valve control knob to the PILOT position.
6. Without pressing the control knob down, it should be impossible to light the pilot.
7. Relight the pilot following the lighting instructions found on the inside of the heater.
8. Reset the temperature control.
9. Light the heater following the instructions found on the inside of the heater.

5.2.11 Testing the Safety Shutoff (for automatic pilot)

1. Find the red silicone rubber insulated wire that runs from the pilot to the ignition stud on the ignition control module.
2. With the main burners firing, use an insulated pair of pliers to disconnect the sensor wire from the control module. Do not pull on the wire. The main burner flame should immediately go out.
3. Turn the gas valve control knob to the off position.
4. Reattach the red silicone wire to the control module.

5.2.12 Testing the Igniter Electrode

To test the igniter electrode:

1. Make sure all of the wire connections on the ignition control and the gas valve are tight.
2. Make sure the wiring agrees with the wiring diagrams found on the inside of the heater.
3. Check for sparking at the igniter electrode.
4. If there is sparking at the igniter electrode, but there is no pilot ignition after 10-20 seconds, clip a lead from the voltmeter between the yellow wire terminal on the transformer and the orange wire terminal on the gas valve.
5. If the voltmeter does not show voltage, replace the ignition control.

6. If the voltmeter reads 24 to 28VAC, but there is no pilot ignition, check for
 - a: air in gas lines.
 - b: restrictions in gas line, valve or pilot tubing.
 - c: clogged pilot orifice.
 If these are correct then replace gas valve (see Section 4.2).

WARNING

Never attempt to repair the gas valve. Such attempts will void the warranty, and could lead to dangerous results.

5.2.13 Testing the Pilot Thermocouple (for standing pilot)

If there is voltage to the gas valve, the pilot is lit, the thermocouple is properly positioned, the temperature control is set high enough to call for heat; then the gas valve or the pilot thermocouple may be the problem. To test the pilot thermocouple:

1. Remove the pilot thermocouple fitting from the gas valve.
2. Clip one lead of a millivolt meter on the center post of the tube and the other lead on the copper pilot thermocouple shield. Turn the gas valve control knob to the "Pilot" position, depress it, and light the pilot. You will have to keep the gas valve control knob depressed throughout this test.
3. If the millivolt meter reads about 30 millivolts, go to step 5.
4. If the millivolt meter does not show voltage or voltage is very low, it could indicate a dirty or clogged pilot. Clean and recheck the pilot thermocouple. If voltage still does not show or is very low, replace the pilot thermocouple.
5. To test the pilot thermocouple under load, screw the pilot thermocouple into the end of a millivolt reading adapter (see Figure 42).
6. Clip one lead of a millivolt meter to either side of the millivolt adapter and clip the other lead to ground.
7. Light the pilot following the instructions found on the inside of the heater.
8. Set the temperature control high enough to call for heat.
9. With the heater firing, take a millivolt reading.
10. If the millivolt meter does not read about 10 millivolts, replace the pilot thermocouple.

5.2.14 Testing for Pilot Burner (for spark ignition)

When the pilot burner lights, the sparking should stop and the main burners should fire. If the sparking continues and the main burners do not fire:

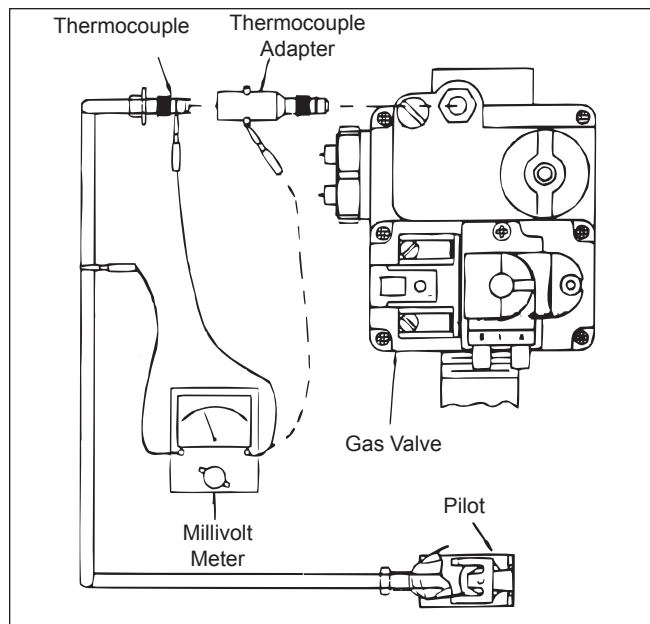

Figure 42. Testing the pilot thermocouple.

1. Check all wire connections, ignition cable, and using a mirror, make sure there is a pilot flame.
2. If everything appears all right, measure flame sensing current by connecting a direct current (DC) microamp meter between terminal No. 12 and the GND (BURNER) terminal on the ignition control (see Figure 43).

NOTE: Separate the microamp meter leads from each other and clear the heater chassis for most of their length to properly perform this test.

3. When the pilot lights, the microamp meter should read 1.5 microamps or more with or without the main burners firing. A smaller current could be caused by poor pilot flame, the position of the pilot electrode, or bad cable and connectors.
4. If the pilot flame and sensor electrode are all right, but there is no main burner ignition, clip one lead from a volt meter between the yellow wire terminal on the transformer and the brown wire terminal on the gas valve.
5. If the voltmeter reads between 20 to 28VAC, but the main burners do not fire, replace the gas valve (see Section 4.2).

5.2.15 Testing for Burner Ignition (for standing pilot)

If the pilot flame and pilot thermocouple generator are all right, but there is no main burner ignition:

1. Clip one lead of a volt meter between the yellow wire on the transformer and the brown wire terminal on the gas valve.
2. If the volt meter reads between 20 to 28VAC, but the main burners do not fire, replace the gas valve (see Section 4.2).

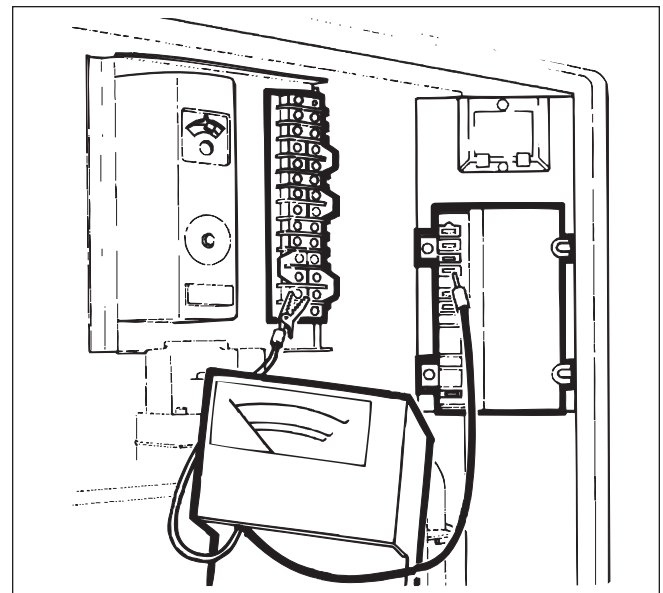

Figure 43. Flame sensing current.

5.2.16 Heater Will Not Shut Off

1. If the heater stays on with the brown wire on the gas valve disconnected, replace the gas valve (see Section 4.2).

⚠ WARNING

Never attempt to repair the gas valve. Such attempts will void the warranty, and could lead to dangerous results.

2. Check electrical components for loose wires. Disconnect one of the lead wires on the gas valve. If the heater goes off, the wiring could be at fault. Repair or replace as necessary.

5.2.17 On-Off Main Burner Cycling

The main burners cycling on and off can be caused by:

1. Poor wind conditions on an outdoor installation.
2. Pilot components out of position.
3. Low gas pressure causing an improper pilot flame.

The pilot flame may appear to be all right until the main burners come on, then the pilot flame shrinks. An undersized gas supply line may cause this.

5.2.18 Testing the Terminal Strip/ External Controls

The terminal strip has been included so the heater can be operated by various external controls not provided by Bradford White. Determine whether or not an external control is open by checking for voltage at each terminal. If there is voltage at one terminal and not the other, examine the external control. It may require service or replacement.



H2317000-



Ambler, PA 19002
Tech. Service (800) 334-3393
Service Parts (800) 538-2020
Warranty Service (800) 531-2111

www.BradfordWhite.com

Litho in U.S.A. © Bradford White 0602 Document 2143