



## Lithium Ion Battery Low Voltage Disconnect Installation and User Manual

### Introduction

The Low Voltage Disconnect (LVD) is used to protect lithium ion batteries from damage due to over discharge. The LVD is suitable for use with battery systems of 12V, 24, 36V and 48V. Its outputs will drive contactors or relays directly.

The LVD is intended to be used in combination with Elite Power Solutions battery cell balancers as a lower cost alternative to a full BMS system for low voltage applications.

### LVD Connections



## Connections:

Ground	Battery Negative or ground
Key SW	Key Switch input or battery positive
No Delay	Non-Delayed Output
Delay	Delayed Output

Use insulated ¼" female spade terminals to make all connections to the LVD. These are readily available at hardware stores.

## LVD

The LVD circuit will prevent damage to the battery pack from over discharge. The LVD has two outputs, delayed and non-delayed. These pins will output pack voltage and can drive up to 2A continuous with an 8A surge for 100mS or less. They can directly drive relay or contactor coils.

One or both of the outputs must be able to completely shut off all loads on the battery pack once activated in order to avoid damage to the battery pack. Recharging the battery pack as soon as possible after an automatic shut off event is recommended.

**Non- Delayed Output** – When power is applied to the LVD and voltage is above 3.1V per cell this output will immediately turn on. When the voltage drops below 2.9V per cell for a period of 15 seconds this output will shut off. Once the output has shut off it will not turn back on until the voltage has risen to 3.1V per cell.

**Delayed Output** - When power is applied to the LVD and voltage is above 3.1V per cell this output will turn on after 5 seconds. When voltage drops below 2.9V per cell for a period of 30 seconds this output will shut off. Once the output has shut off it will not turn back on until the voltage has risen to 3.1V per cell.

## Settings

The LVD can be set for 4 cells 12V, 8 cells 24V, 12 cells 36V, or 16 cells 48V. The voltage setting must be made correctly for the LVD to operate properly. There are two jumpers on the back of the LVD which can be positioned as below to correspond with the appropriate number of cells.

### Jumper Settings

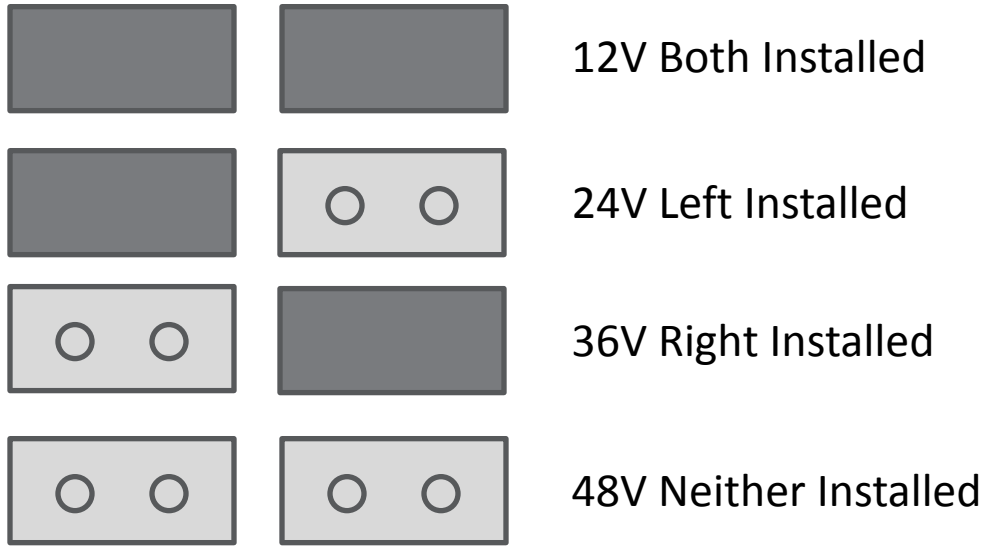

### Basic Schematic

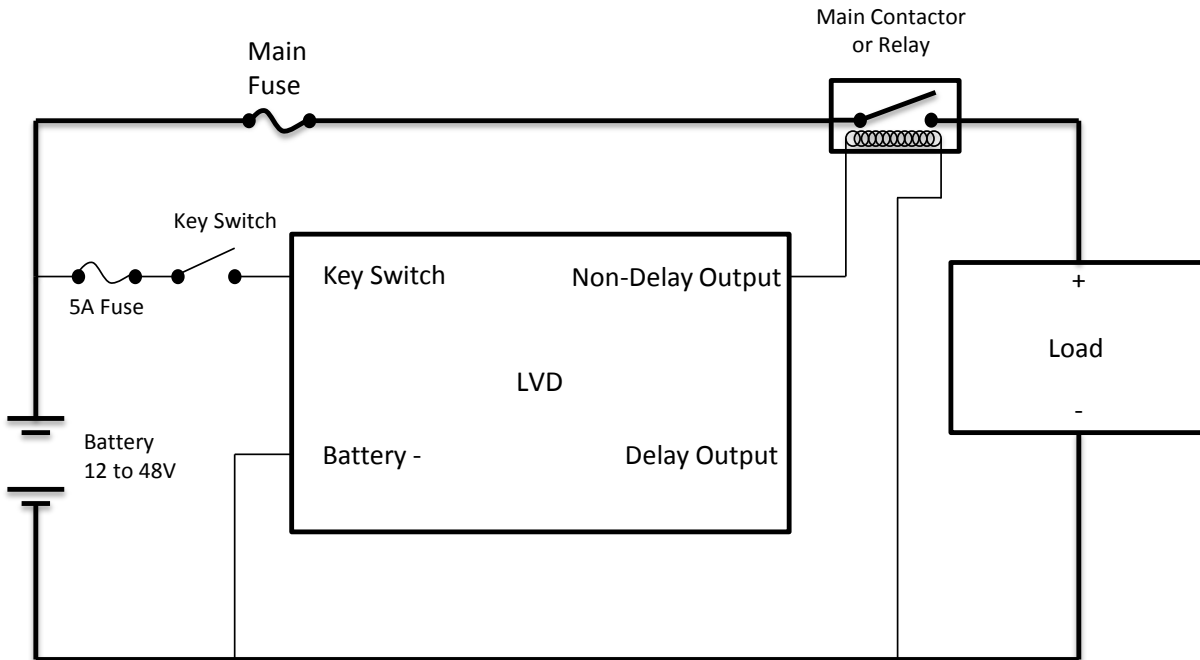

# Typical Golf Car Application

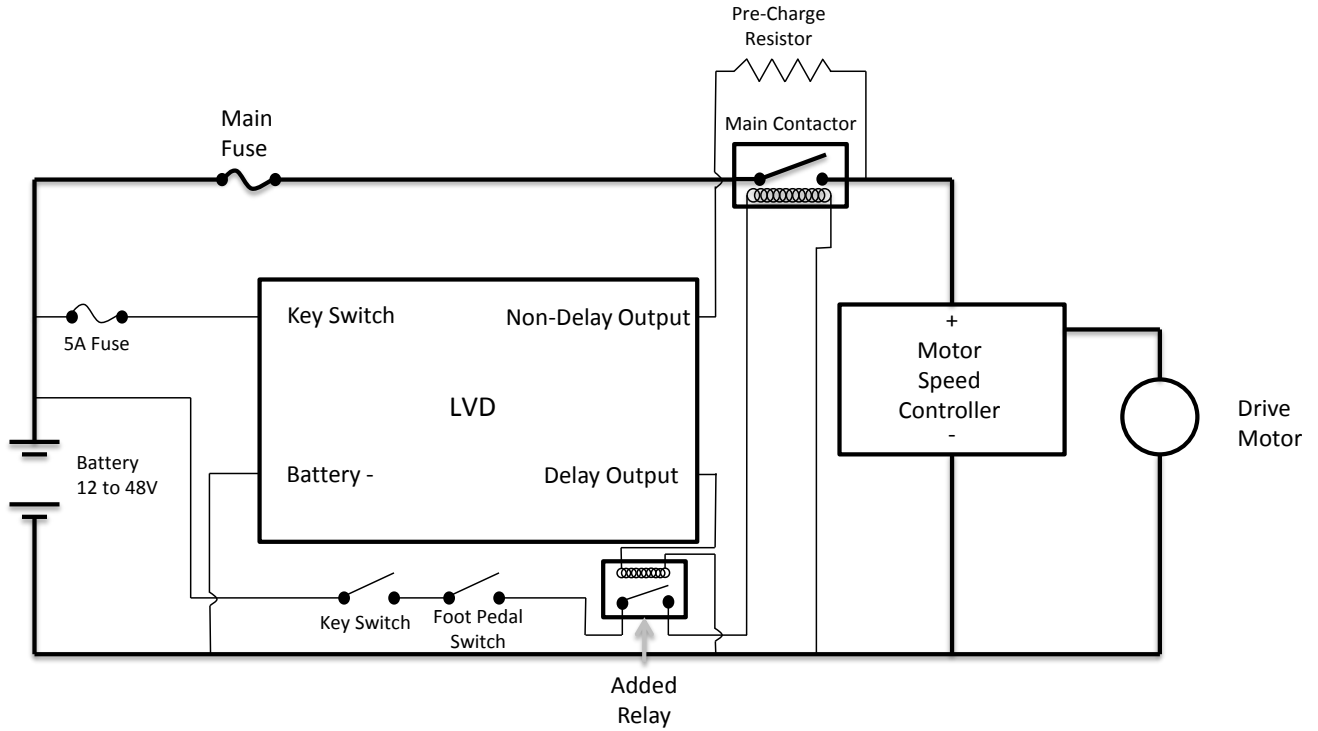
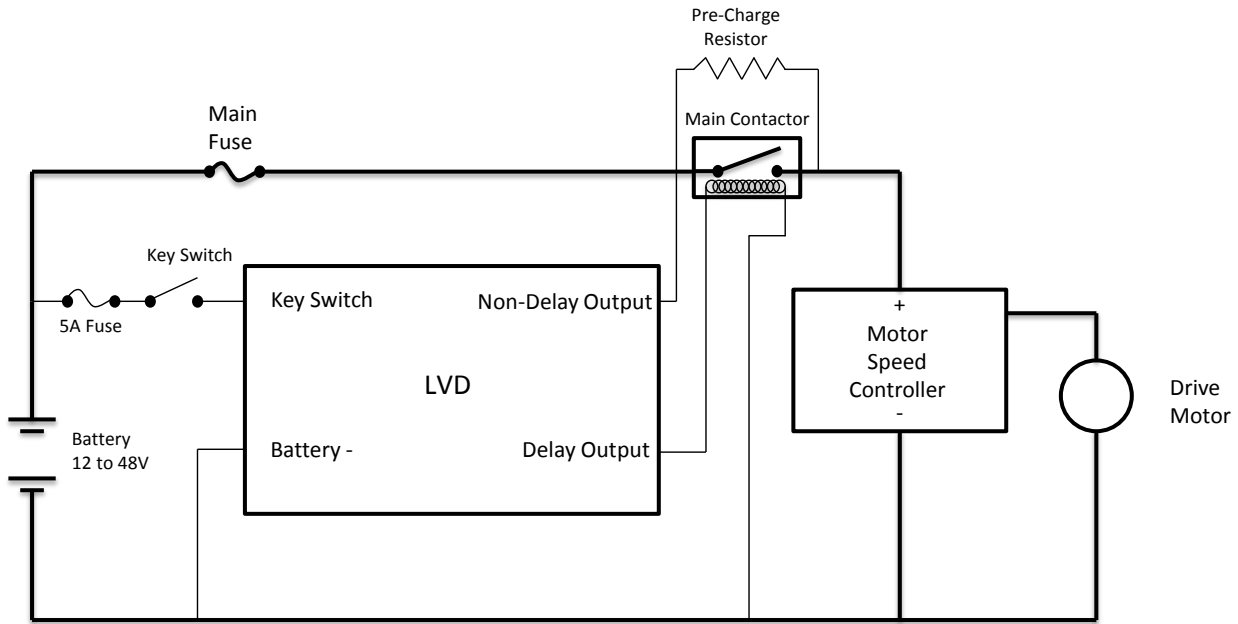

In some golf cars, the foot pedal controls the main contactor. The foot pedal is connected directly to the key switch and this point is not easy to get to. A relay can be added as shown to control the signal from the foot pedal.