

MOTOYAMA

INSTRUCTION MANUAL

Model 83A-BS & 83A-BSH

SEAL-RING BALANCE TYPE **CAGE GUIDED CONTROL VALVES**

 **MOTOYAMA ENG. WORKS, LTD.**

Introduction

Thank your very much for choosing MOTOYAMA Control Valves.



To use this product safely and to optimize its performance, it is recommended that the following instruction should be read carefully and followed.

1 General

- 1 Keep this instruction manual in operator's hand.
- 2 Before using this Control Valves, read this instruction manual carefully and fully understand it for operation.
- 3 This instruction manual does not cover the Accessories installed to the Control Valves.
Kindly refer appropriate Accessories' Instruction Manual along with this manual.

2 For Safety Use

To use this Control Valves safely, this instruction manual describes symbols and signal terms in accordance with JIS Z2901 and ANSI Z5351 which shall call your attention to keep safety manner or to give caution of handling, together with notes. Important information has been marked and emphasized with the following symbols in this Instruction Manual.

Symbols & Signal Terms	Explanation
 WARNING	A direct endangerment of a person's health or life may occur if the Warning was not observed.
 CAUTION	If the Caution was not observed, minor personal injuries and/or property damages may result.

3 Note

MOTOYAMA is continuously improving and upgrading its product design, specifications and/or dimensions. Information included herein is subject to change without notice.

MOTOYAMA ENG. WORKS, LTD. SHALL NOT BE LIABLE FOR TECHNICAL OR EDITORIAL ERRORS OR OMISSIONS CONTAINED HEREIN ; NOR FOR INCIDENTAL OR CONSEQUENTIAL DAMAGES RESULTING FROM THE FURNISHING, PERFORMANCE, OR USE OF THIS MATERIAL.

Transportation, Unpacking, Check and Storage

1 Transportation

 CAUTION	<p>When loading or unloading and transportation of Control valves, pay full attention not to drop or not to give shock with hitting or bumping etc. It would make the Valves and its accessories mechanical troubles or damages as of precision instrument.</p>
--------------------	---

If any cautions/instructions or care marks are indicated on the package, follow them as it is.

2 Unpacking

- (1) There are two types of packages used for Control Valves, wooden crate/box and carton. In either case, unpack the crate/box or carton indoor or in warehouse.

 CAUTION	<p>Never unpack the package of Control Valves outdoor place where rain falls, on damp and wet ground and/or where dust is in the air. It would make the Valves and its accessories mechanical troubles or damage because of precision.</p>
--------------------	--

- (2) When unpacking the wooden box, follow the procedure described below unless otherwise specified.

Pull off round pegs around edge protectors at each corner and remove them.

Pull off round pegs stuck on roof (top) and remove the roof (top).

Remove waterproofing materials, if applied, inside of the box.

Pull off round pegs stuck on frame at side and remove side plates.

Pull off round pegs stuck on frame at end and remove end plates.

If the goods are fixed with square-lumbers or bolts and nuts, remove them.

Remove waterproofing materials such as polyvinyl packing covering the goods.

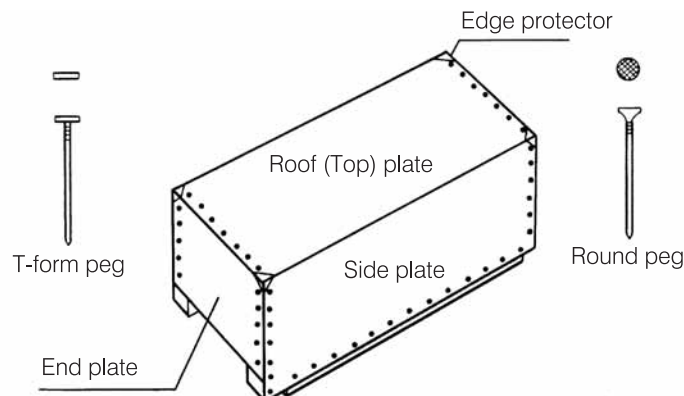

[Note] T-form pegs are not required to be pull off when unpacking.

3 Check of the Products

[Caution] After receiving the goods, unpack the packing promptly and check if the goods delivered are complying with your order specification.

When taking out the goods from box, pay attention not to give any physical shock to the Accessories attached to the Valves. Take out the spare parts if they are enclosed.

Check the Name Plate attached to the Yoke of Actuator whether Valve specification complying with your request.

If any clarification required on the received goods, please contact MOTOYAMA sales office specifying Serial No. and Model Number indicating on Name Plate attached to the Valves.

4 Storage

If the goods need to be stored before installation, store the goods in warehouse or equivalent indoor storage facility, covering whole the goods with cover like polyethylene sheet and protect the goods from high temperature, moisture, dust and vibration etc.



During storage of the goods, protect Conduit connection of electrical instrument from moisture or water which would give breakdown of the electricity and cause trouble on the product.

If the period of storage is exceeding one (1) year after delivery, re-calibration of the Valve action and checking of gland and gasket leakage before installation must be made. Please contact MOTOYAMA sales office when re-calibration is requested.

CONTENTS

	Page
1 . Purpose of this Instruction Manual	1
2 . Application of Control Valves	
2.1 Purpose of Use	2
2.2 Construction	2
2.3 Specification	5
3 . Installation	
3.1 General	6
3.2 Installation on System Piping	7
3.3 Inspection after Installation	7
4 . Operation, Check and Maintenance	
4.1 Precautions and Check before Operation	8
4.2 Greasing to Gland Packing	9
4.3 Check and Maintenance	10
5 . Disassembling and Re-assembling	
5.1 Split of Actuator from Valve Body	11
5.2 Disassembling and Re-assembling of Valve Body	12
6 . Trouble Shooting	22
7 . Recommended Spare Parts	24
8 . Disposal of Control Valves and Parts	25
Reference Data <Estimated Life-Cycle of Control Valve parts>	26

1 Purpose of this Instruction manual

- (1) This Instruction Manual provides the essential information for optimizing MOTOYAMA Diaphragm Actuated Seal-Ring Balanced Cage Guide Globe Type Control Valves, Model 83A-BS and 83A-BSH for safety operation.
- (2) Read this manual carefully before installing, operating or overhauling MOTOYAMA Control Valves, Model 83A-BS and 83A-BSH.
- (3) Together with this manual, read the following Accessories' manuals before using, when applicable.

Accessory Name	Bulletin No.
Model 01, 05, 83A, 83, 89 Globe Type Control Valves USER'S MANUAL	MIE-B3001
Electro-Pneumatic Valve Positioner EA91A, EA90A	MIE-B6104
Pneumatic Valve positioner PA92A	MIE-B2008
Air Filter Regulator MR2000	MIE-B6903

- (4) If any other Accessories are installed on the Valves delivered, kindly request our sales office appropriate Instruction Manual, if necessary.

2 Application of Control Valves

2.1 Purpose of Use

Model 83A-BS and 83A-BSH Control Valves are installed in process piping and used to Control process flow, activating Valve Plug open and close or throttling the Valve Plug and seat replying Control signal such as 4 ~ 20mA DC or 20 ~ 100kPa from Controller in instrumentation system, to keep the specific and/or the constant process conditions.

Applicable Pressure and Temperature range of Model 83A-BS and 83A-BSH are as follows.

Model	Applicable press. Range	Applicable Temp. Range
83A-BS (for medium Temp.)	9.8MPa (100kgf/cm ² G)and lower	- 50 ~ + 230
83A-BSH (for high Temp.)		+ 500 and lower

2.2 Construction

- (1) Model 83A-BS and 83A-BSH consist of Body Assembly and Actuator Assembly.

Body has Controlling mechanism actually Control the process flow and Actuator has driving mechanism to activates Valve Plug receiving air power source.

Seal-Ring design for Model 83A-BS and 83A-BSH are given below.

	Model 83A-BS	Model 83A-BSH
Materials	Seal-Ring: carbon graphite composite PTFE	Seal-Ring: Metal sintered carbon
	Back-up Ring: carbon graphite composite PTFE	Tension-Ring: SUS316
Structure	Seal-Ring is installed between Holder and Cage. Back-up Ring is installed for port size 200 and larger together with Seal-Ring. Seal-Ring seals guide clearance flow contact with Valve Plug sliding surface.	Seal-Ring is installed in the groove of the Valve Plug with Tension-Ring (inside). Seal-Ring seals guide clearance flow contact with guide sliding surface.

Fig. 2-1 (page 3) shows constructions of Model 83A-BS and Fig. 2-2 (page 4) shows Model 83A-BSH.

Body and Bonnet are jointed together with Stud Bolts, Nuts and Gasket and provide pressure containing parts where process flow runs through or stay.

Valve Plug is led by Cage and keep proper position by Actuator Controlled by signal to the Actuator.

- (2) See Bulletin No. MIE-B3001 "Globe Type Control Valves, USER'S MANUAL" for the details of Actuator construction.

Fig.2-1 Model 83A-BS Control Valves

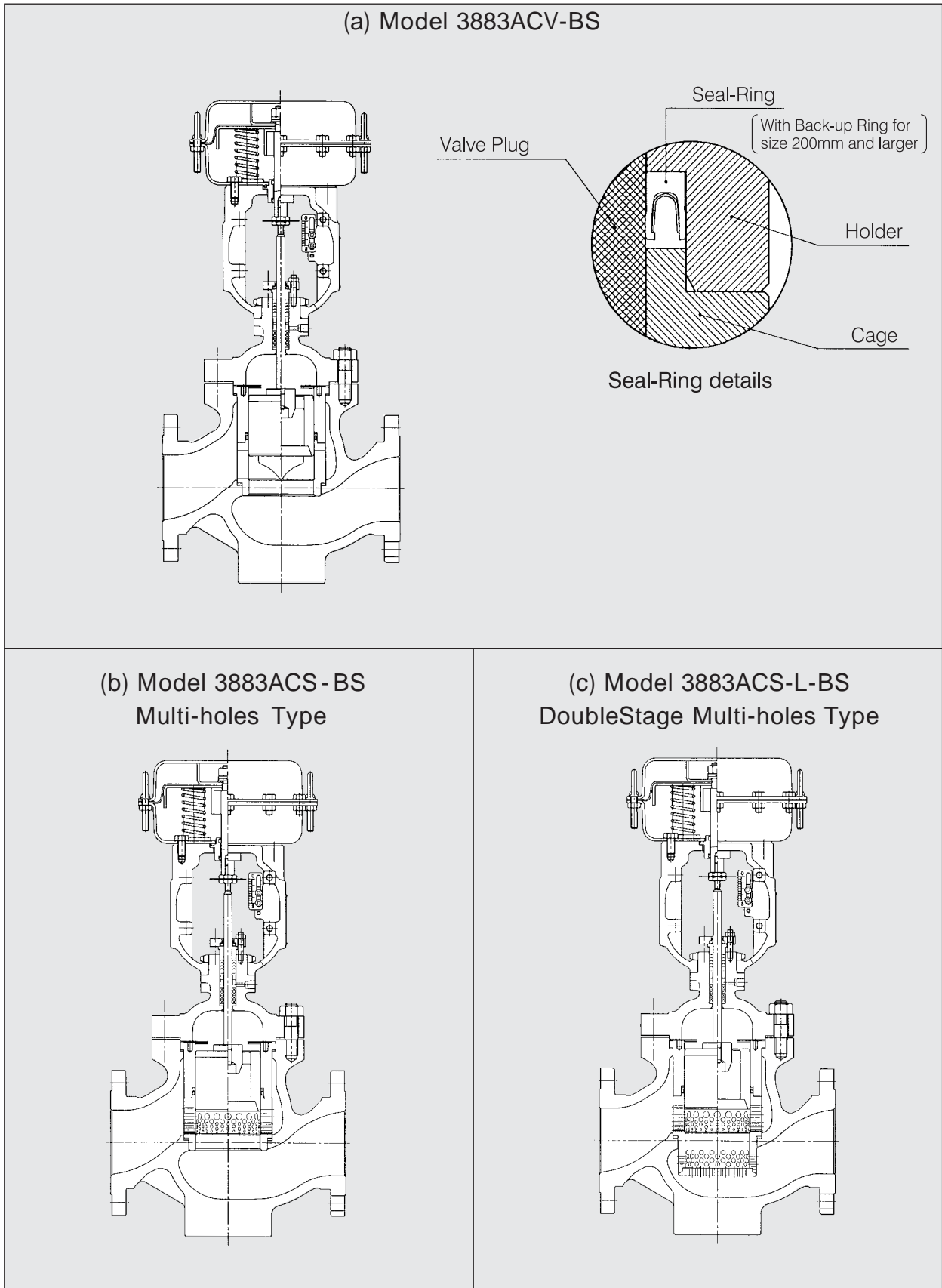
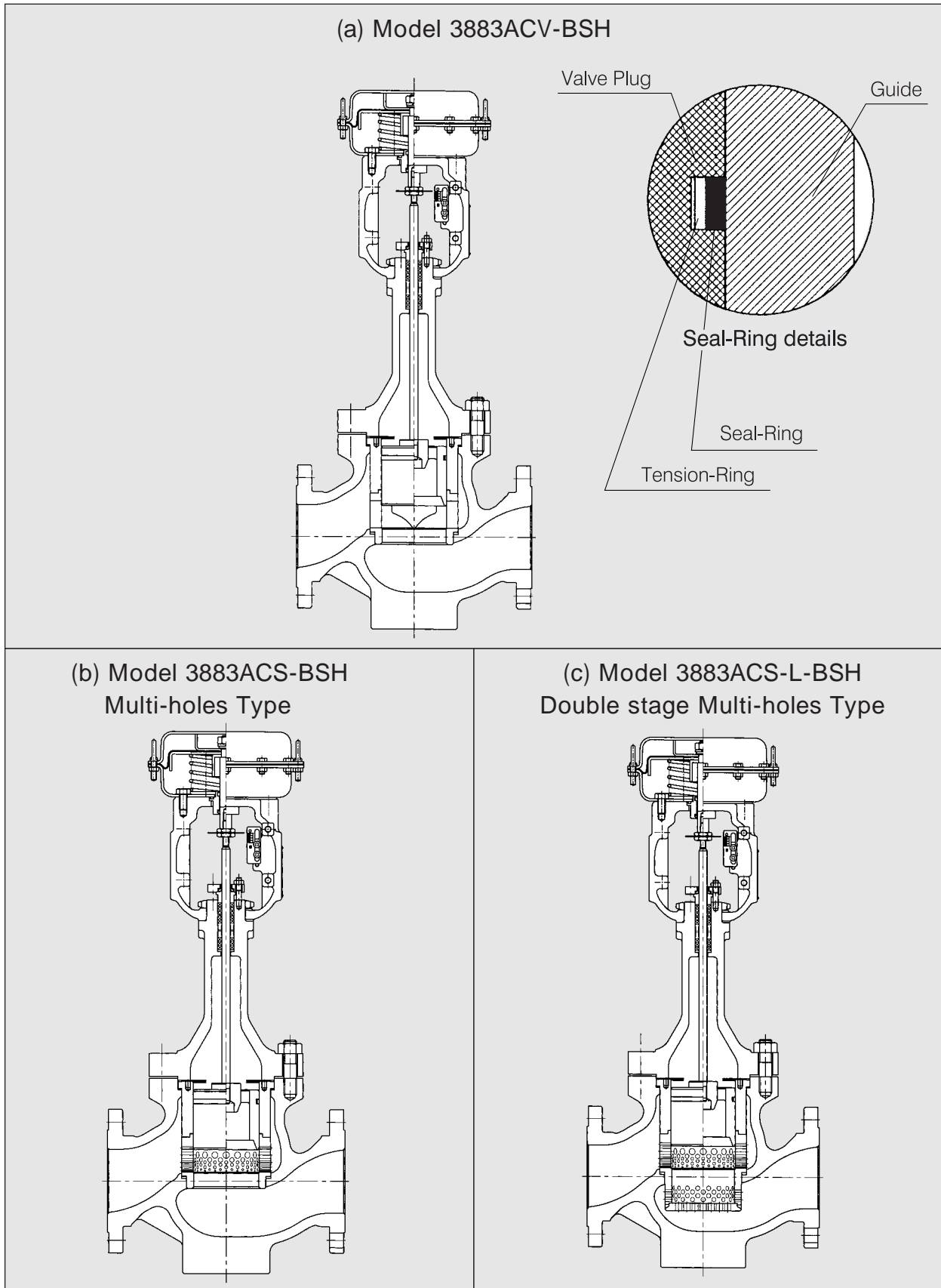



Fig.2-2 Model 83A-BSH Control Valves



2.3 Specification

See Catalog (Bulletin No. MCE-B4307) for detail specification of Model 83A-BS and 83A-BSH Control Valves.

 CAUTION	Do not use the products beyond the selected specification, code, standard and/or regulations to secure the safety of the delivered products.
---	--

Model 83A-BS and 83A-BSH Control Valves have some limitation for usage because of Seal-Ring materials. Following condition shall be reviewed before installation.

2.3.1 Model 83A-BS

 CAUTION	Do not use the products for following services because carbon graphite composite PTFE is used for Seal-Ring material. <ul style="list-style-type: none">• Food processing services• Oxygen services• Services where coloring is done or resin debris is a problem.• Acid at high-temperature and pressures(Aqua Regina, Nitric, Sulfuric Acid)• Fluorine gas (F₂), ClF₃, OF₂ etc. at high temperature.• Metal hydrides such as 80%KOH and B₂H₆.
---	---

Model 83A-BS may be applicable for above services by changing Seal-Ring material. Please contact MOTOYAMA sales office for details.

2.3.2 Model 83A-BSH

 CAUTION	Be sure to use the Valves under following condition because Seal-Ring is made of metal sintered carbon. Seal-Ring material is easy to be oxidized in oxidizing condition. Service condition of the Valves shall be within the following temperature range. *1. For oxidizing fluid : 0 ~ +400 *2. For steam service and non-oxidizing fluid : 0 ~ +500 Kindly check the availability of the Seal-Ring for the service of strong acid fluids or chemicals higher than 100 .
---	--

3 Installation

3.1 General

Control Valves shall be installed in vertical to the piping line in general or Valve Stem shall be vertical to the ground.



CAUTION

Keep sufficient space to the Valves to be accessible to operate safely and to make maintenance work, inspection and testing easily.

Eye-Bolts (Nuts) on Diaphragm case assembly must be used only for hanging Actuator assembly. Do not hang up complete Valves using Eye-Bolts after assembling Body and Actuator. In any case, the following mass shall not be exceeded to hang up.

[Unit : kg]

Actuator Model No.	Actuator Size	Allowable Hung Up Mass	Actuator Mass
3800	N24	80	12
	N28	150	15
	N33S	150	24
	N40	220	49
2800	500 S/L	220	85/102 <small>(Note 2)</small>
	650 S/L	900 <small>(Note 3)</small>	270/275 <small>(Note 2)</small>
	650X S/L	900 <small>(Note 3)</small>	365/395 <small>(Note 2)</small>

【Notes】

- (1) See catalogues for each Valves mass.
- (2) Actuator mass is for direct action.
- (3) Only when using four (4) Eye-Bolts for 650S/L and 650XS/L Actuator. Other size of Actuator, allowable lifting load is permissible using two (2) Eye-Bolts.

Ambient temperature and humidity for the Valves should be - 20 ~ +70 , and be less than 90% RH.



WARNING

Never use the Valves on the service condition exceeding the rating and the standard of connection to prevent the Valves from damage, breakage and/or leakage.

3.2 Installation on System Piping

- (1) Remove all welding chips, scales and other foreign matters from internal of the piping line before installing the Valves in between.
- (2) Be sure to match arrow mark on the Valve Body to the flow direction when installing.
- (3) Piping Gasket shall be installed properly not to be out into the Body bore diameter.
- (4) Be sure the concentricity and parallelism of the Valves inlet and outlet piping are correct. Tighten Bolts and nuts equally. Be sure not to give the excessive stress to the Valves.

 CAUTION	<p>When tightening, be sure not to give excessive load (piping stress) to the Valves which would cause damage, deformation and leakage.</p> <p>Seat leakage would increase if Valves installed in-correct flow direction and durability of the Seal-Ring will be deteriorated. Do not use Valves on services which create back pressure to Valve.</p>
---	---

- (5) Blow off scales, rust and foreign matters in pneumatic piping by compressed Air before connecting pneumatic piping to the Actuator and accessories.
- (6) Refer to each instruction manuals for wiring the conduit of electric equipments.
- (7) For Finned or Extension Bonnet Valves, do not cover Bonnet with heating or cooling insulation.

 CAUTION	<p>Either Body or Actuator, or the both, should be supported by proper way.</p>
---	---

3.3 Inspection after Installation

- (1) Carry out leakage test to check leakage from the connection piping.
- (2) Check leakage from Gland or Gasket after test pressure is applied to the piping.
If any leakage is found, reduce the pressure and retighten Gland Nuts or Stud Nuts with equally.

 CAUTION	<p>If more than 6 months past before starting operation of the system, retighten Gland Nuts before starting pressure tightness test. After re-tighten Gland Nuts, reciprocate the Valves at least 10 times from fully open to fully close to fit Gland Packing for operation.</p>
---	---

4 Operation, Check and Maintenance

4.1 Precautions and Check before Operation

- (1) Spring range and Off-balance for Model 2800 series Actuator is adjusted properly to the required specification when shipped. Do not turn Adjusting Screw unless otherwise it should be.
- (2) Before start operation, check Stem Nuts, Actuator Bolts and Nuts and other screws to be tightened. Re-tighten if necessary.
- (3) Some Gland Packing might have leakage because of stress relaxation. Check the tightness of Gland Nuts and re-tighten if necessary.
- (4) When Lubricator is equipped on Bonnet (page 9 & 10), check if Grease filled enough. Be sure to close the Stop Valve after filling the Grease. See Table 4-1 to select appropriate Grease for each services. Please contact MOTOYAMA sales office when replacement Grease is required.

 CAUTION	<p>If more than 6 months past before starting operation of the system, re-tighten Gland Nuts before starting pressure tightness test.</p> <p>After re-tighten Gland Nuts, reciprocate the Valves at least 10 times from fully open to fully close to fit Gland Packing for operation.</p>
---	---

Table 4-1 Grease

Maker	CLIMAX Co.			THREE-BOND Co.
Grease No.	#400	#650	#750	#1901
Operating Temp.()	- 29 ~ + 230	- 40 ~ + 260	0 ~ + 300	+ 300 ~ + 450
Color	Red	Blue	Black	Black
Services	Amine Chloride Acid Chlorine Alkali Food Alcohol Bleach Ammonia Cyanide Co Milk Brine Paints Sulfur	Acetylene Vinyl Chloride General Gas Hydrocarbon Mineral Oil Freon	Asphalt Coke oven gas Coal tar Steam Phosphorus Water	Stem General high temperature fluid
Shape	Stick	Stick	Stick	Bulk (Can)

[Note] No Lubricator is installed for the services fluid temperature is lower than -40 .

- (5) When Hand Wheel is mounted, be sure Handle is set to the "Neutral" or auto operation position which does not restrain Valve opening.
- (6) Carry out loop test with the Controller to check that the Valves open or close smoothly.

 CAUTION	<p>If the Valves must be heated up, increase the temperature and pressure gradually without changing them rapidly. Heating up speed shall be less than 100 °/Hr. During heating up, be sure to avoid sudden operation.</p>
--------------------	--

4.2 Greasing to Gland Packing

- (1) To use Braided Packing, it is required to use Greases to elevate the sealing and lubricating property on Valve Stem.
- (2) The greasing device to inject the Grease is called Lubricator.
Fig. 4-1 shows the construction of Lubricator.
- (3) To supply the Grease in routine work, follow the procedure below.

Turn the Handle clockwise to make the Spindle closed.

(If the Pressure Screw is removed holding the Spindle open, Grease may flow out reversely by internal pressure from Valve Body.)

Take out the Pressure Screw from Cylinder.

Insert designated Grease from this open port.

Use the designated Grease specified on the Name Plate attached on Actuator

Compress the Grease into the Lubricator by the Pressure Screw.

Under compressing the Grease by Pressure Screw, turn the Handle counter-clockwise to make the Spindle open. Then compress the Grease further by Pressure Screw. After compressing, turn the Handle clockwise and close the Spindle.

- Repeat above operation , , several times and fill the Grease into the Connection Pipe and Cylinder.

 CAUTION	<p>Do not fill the Grease too strong or too much to prevent overflow from Bonnet Staffing Box or to prevent the damage of Gland Packing itself. Pay attention to the overflow from Staffing Box, Guide Bush and/or Valve Stem when greasing.</p>
--------------------	--

Turn the Handle clockwise to make the Spindle closed and Greasing is completed.

After greasing, open and close the Valves several times (around 10 times) to create uniformed grease film between Gland Packing and Valve Stem.

Fig.4 Lubricator

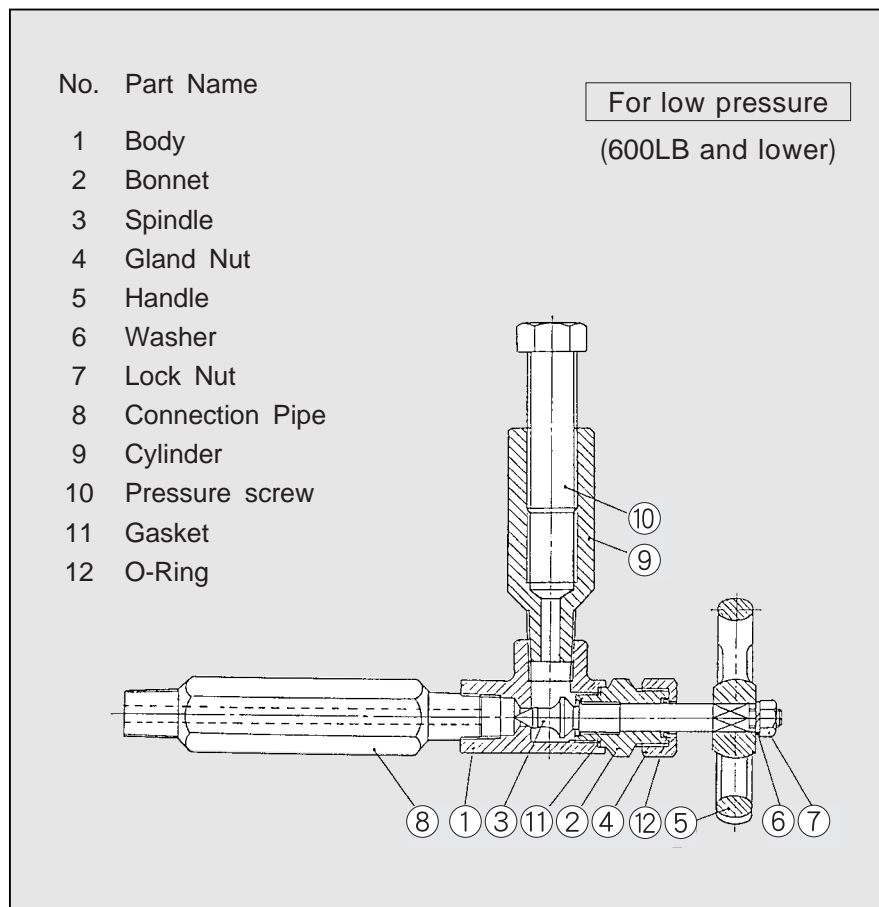

4.3 Check and Maintenance

To maintain maximum efficiency on your Control Valves, it is recommended to check or proceed maintenance work as follows. (See Paragraph 6. Trouble shooting on page 20-21)

(1) Daily Check

Check leakage, abnormal sound, vibration and/or hunting

(2) Periodical Check [Annually]

Check each parts of the Valves, re-tighten the Gland and replenish/replace Grease if necessary.

(3) Overhaul..... [Body: Once in every 2 years, Actuator: Once in every 5 years]

Disassemble the Valves and check the internal parts. (See Chapter 5)



When leakage is found from the Valve or piping, Do Not Touch or Access to the fluid until the safety is confirmed by proper responsible person.

5 Disassembling & Re-assembling

Following is recommended procedure to disassemble or re-assemble Valves.

 CAUTION	<p>Please prepare following spare parts available before disassembling: Gland Packing, Gasket Packing, Seal-Ring (Model BS and Model BSH) and Back-up Ring (Model BS). Do not reuse the used Gland Packing, Gasket Packing, Seal-Ring (Model BS and Model BSH) and Back-up Ring (Model BS). Prepare required Tools in advance. Never disassemble the Valves on system under existing inside pressure or before cooling down of the Valves completely. Do not turn the Valve Stem when the Valves are closed. On Model 2800 spring diaphragm Actuator, Do Not Turn the Spring Adjuster. Turning of Spring Adjuster makes the change of Spring Range limit, upper and lower.</p>
--------------------	---

5.1 Split of Actuator from Valve Body (See. Fig. 5-1)

 WARNING	<p>To disassemble the Valves on system line, Close the line and Release all the system pressure in advance.</p>
--------------------	---

- (1) Place fitting mark on each connecting parts before disassembling.
- (2) Hold the Valve Plug at full open position depressurizing the supply pressure to zero on direct action Actuator or supplying Air pressure on reverse action Actuator.
- (3) Loosen Stem Nut and Pointer together and go downward, then lock. On Actuator size N33 and larger, lower the Locking Plate together.

Thread size of Valve Stem and Top Stem is as follows.

Actuator size	Thread
N28	M9, P1. 25
N33	M12, P1. 75
N40	M18, P2. 0
500	W3/4-10
650	W7/8-9

- (4) Pull down Valve Stem by turning Stem Nuts with pointer downward from Top Stem.
- (5) Remove Yoke Bolts.
- (6) Pull up Actuator upright and split it from Valve Body.

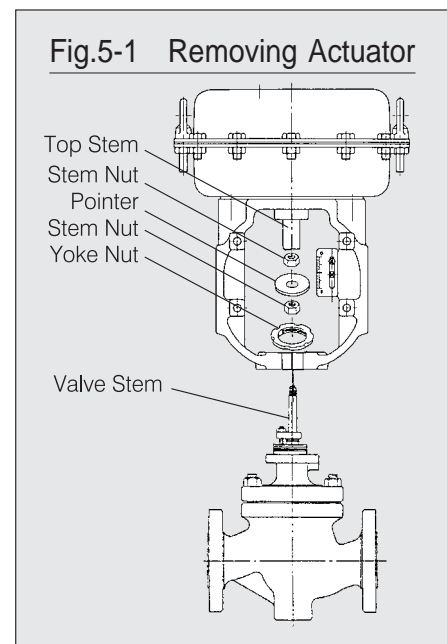

5.2 Disassembling and Re-assembling of Valve Body

To disassembling or re-assembling Valve Body, follow the procedure below. (See Fig. 5-2 ~ 5-10).

Fig.5-2 Model BS Body details

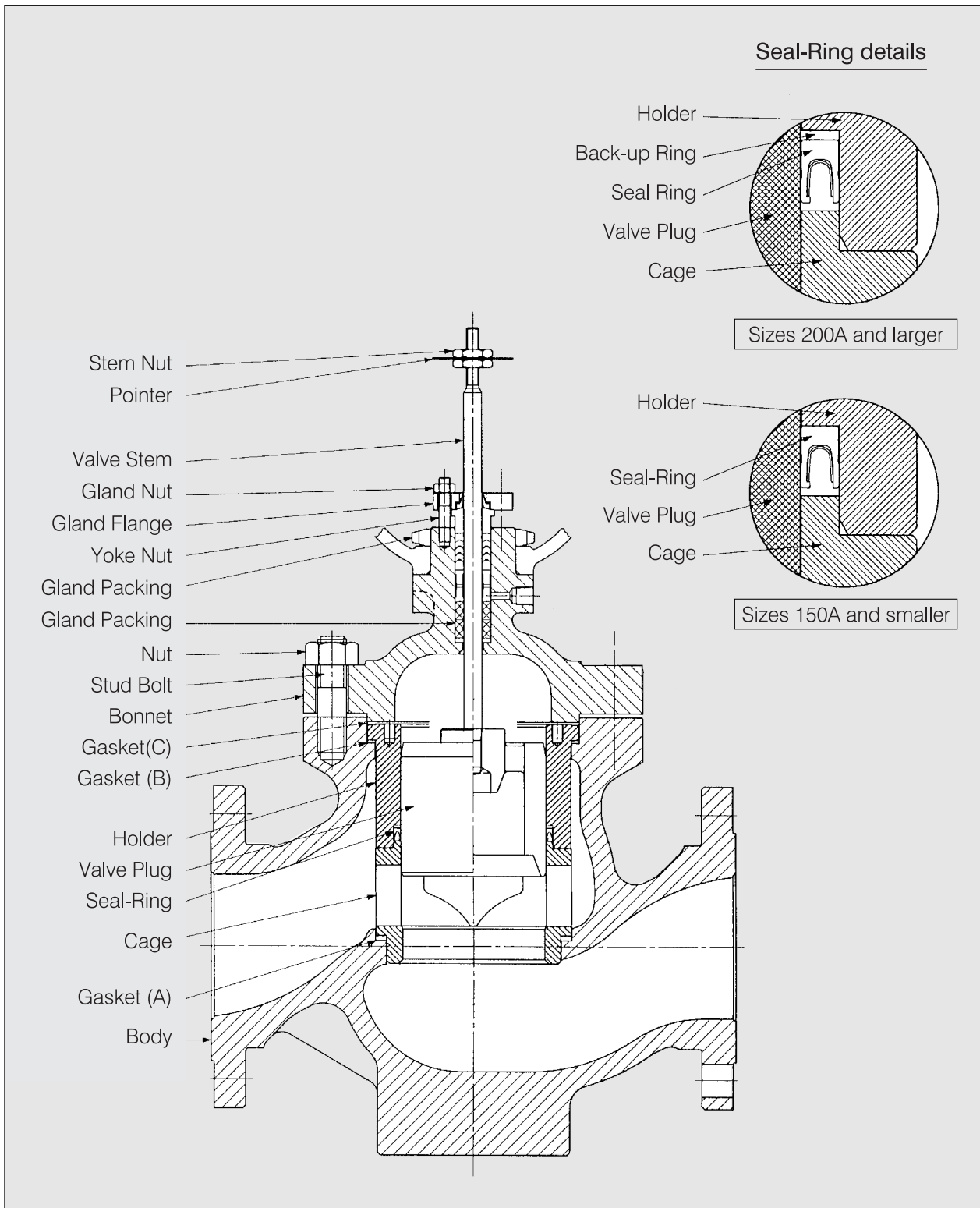
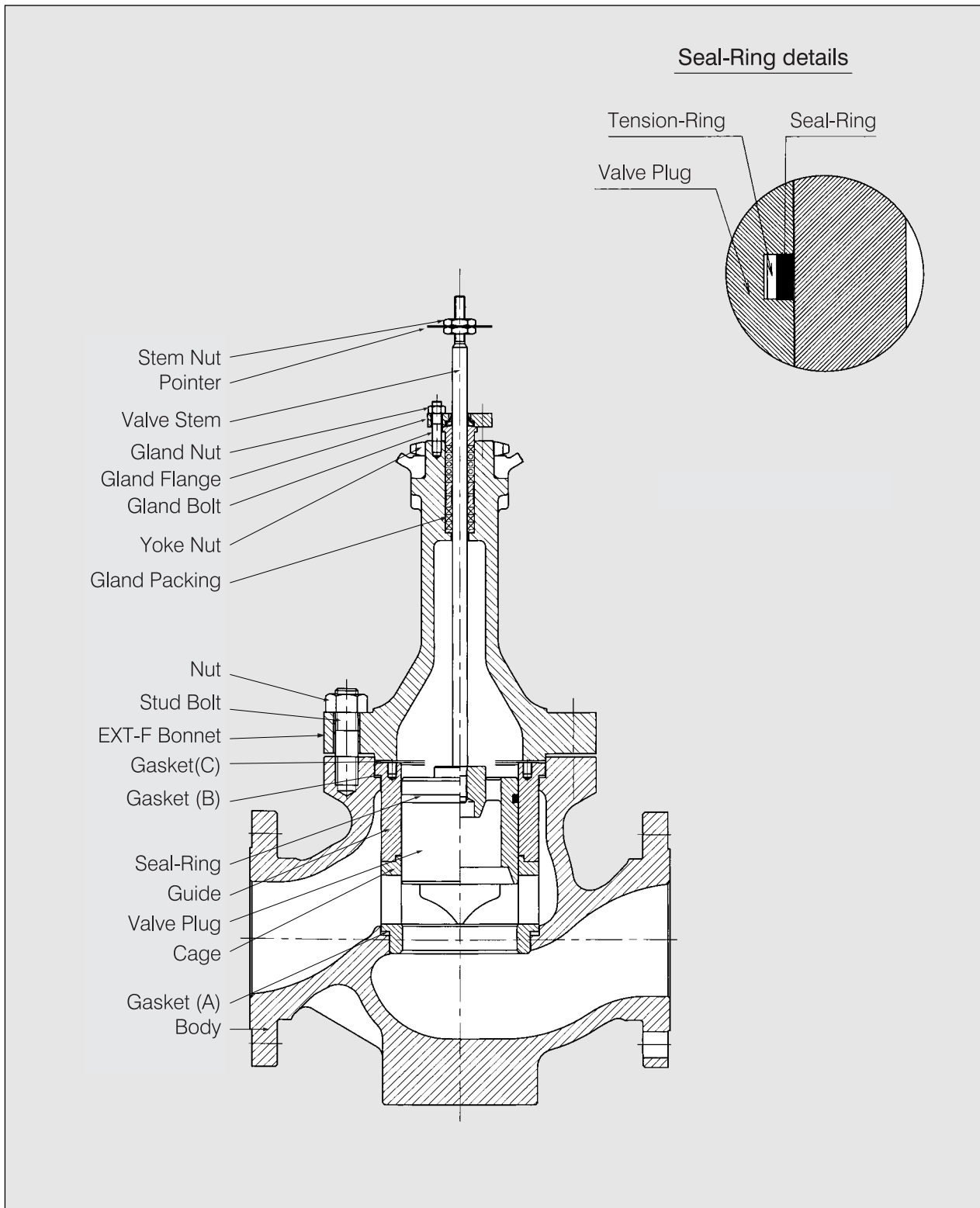



Fig.5-2 Model BSH Body details



5. 2. 1 Disassembling Procedure

5. 2. 1. 1 Model BS

- (1) Remove Stud Bolt Nuts.
- (2) Pull up Valve Plug together with Bonnet upright and split it from Valve Body.

 CAUTION	Be careful not to drop Holder ! Holder might coming up together with Valve Plug.
---	---

- (3) Loosen Gland Nuts and release the tension of Gland Packing.
- (4) Pull down Valve Plug from Bonnet.
- (5) Remove Gland Bushing, Gland Packing, Lantern Ring and Packing Ring from Bonnet gland.
- (6) Remove Cage from Body. In case Holder is remain in Body, remove both Holder and Cage.

5. 2. 2. 2 Model BSH

- (1) Remove Stud Bolt Nuts.
- (2) Pull up Valve Plug together with Bonnet upright and split it from Valve Body.

 CAUTION	Be careful not to drop Holder ! Holder might coming up together with Valve Plug.
---	---

- (3) Loosen Gland Nuts and release the tension of Gland Packing.
- (4) Pull down Valve Plug from Bonnet.
- (5) Gently pull out Guide from Valve Plug when it is coming up with Valve Plug.
- (6) Remove Gland Bushing, Gland Packing, Lantern Ring and Packing Ring from Bonnet gland.
- (7) Remove Cage from Body. In case Holder is remain in Body, remove both Guide and Cage.

5. 2. 2 Inspection of the Parts

5. 2. 2. 1 Model BS

After disassembling, each parts should be cleaned and checked as follows.

- (1) Check seat surface of Valve Plug and Cage to be free from damage and/or deformation.
- (2) Remove Seal-Ring from Holder, check Holder Groove to be free from damage and/or deformation.
- (3) Check Body and Bonnet wall thickness decreased. Check Body and Bonnet sealing surface of Gasket Packing and Gland Packing to be free from damage and/or deformation.
- (4) Check the appearance of Valve Plug, Stem, Holder, Cage and sliding surfaces of each parts to be free from corrosion, erosion, damage and/or deformation.

If any damage and/or deformation are found on each parts, repair or replacement are required. To request repair or spare parts, be sure to inform MOTOYAMA sales office the serial numbers of the Valves specified on the Name Plate.

5. 2. 2. 2 Model BSH

After disassembling, each parts should be cleaned and checked as follows.

- (1) Check seat surface of Valve Plug and Cage to be free from damage and/or deformation.
- (2) Remove Seal-Ring and Tension-Ring from Valve Plug, check Valve Plug Groove to be free from damage and/or deformation.
- (3) Check Body and Bonnet wall thickness decreased. Check Body and Bonnet sealing surface of Gasket Packing and Gland Packing to be free from damage and/or deformation.
- (4) Check the appearance of Valve Plug, Stem, Holder, Cage and sliding surfaces of each parts to be free from corrosion, erosion, damage and/or deformation.

If any damage and/or deformation are found on each parts, repair or replacement are required. To request repair or spare parts, be sure to inform MOTOYAMA sales office the serial numbers of the Valves specified on the Name Plate.



CAUTION

To clean or repair Valve Plug sliding surface of Model BS or Guide sliding surface of Model BSH using fine sandpaper, use sandpaper grade #240 or fine one.

Never use File or Grinder to repair these parts.

5.2.3 Re-Assembling Procedure

	Model BS		Model BSH
Body size	150mm and smaller	200mm or larger	50 ~ 350mm
Trim	See 5.2.3.1 (page 16)	See 5.2.3.2 (page 17)	See 5.2.3.3(page18,19)
Bonnet	See 5.2.3.4 (page20)		

On model BS, two (2) methods of assembling procedure are recommended depend on trim size and weight.

 CAUTION	<p>Be sure to apply anti-seize grease (NEVER-SEEZ or equivalent) on Seal-Ring surface of the Gasket.</p> <p>For "Oil Free" requirement, apply Fluorine type grease (DAIFLOIL or equivalent) slightly</p>
--------------------	--

[Note] NEVER-SEEZ : products of BOSTICK, DAIFLOIL : products of DAIKIN

5.2.3.1 Model BS Trim Assembling [Port Size 150mm or smaller (See Fig. 5-4.)]

- (1) Install Spiral Wound Gasket (A) on Body lower groove and Serrated Gasket (B) on Body upper groove. Install Seat-Ring on Gasket (A).
- (2) Install Seal-Ring on Holder.
- (3) Install Holder onto Cage fitting to Valve Plug. Pay attention not to damage or deform the Seal-Ring.
- (4) Lift up Valve Stem with Holder and insert it into Cage in the body.
- (5) Follow the procedure on Paragraph 5. 2. 3. 4 (1) ~ (7) for further assembly.

 CAUTION	<p>Be sure to install Seal-Ring and Back-up Ring in correct direction. If the direction is not correct, it is not possible to get good sealing. (See Fig. 5-7.)</p> <p>Keep the assembling in order. If install Cage, Holder with Seal-Ring into Body first and then install Valve Plug, it is very easy to damage or deform Seat-Ring. (See Fig. 5-5.)</p>
--------------------	---

Fig.5-4 Assembling Procedure (Correct Way)

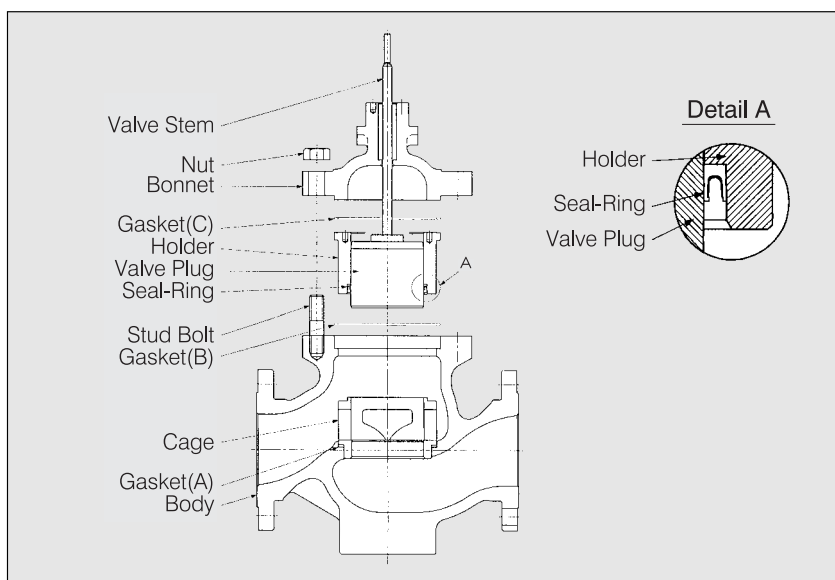
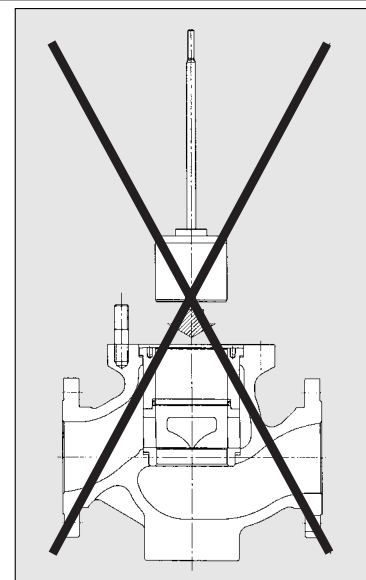

Fig.5-5 Assembling Procedure (Wrong Way)



5.2.3.2 Model BS Trim Assembling [Port Size 200mm or larger (See Fig.5-6.)]

- (1) Install Spiral Wound Gasket (A) on Body lower groove and Serrated Gasket (B) on Body upper groove. Install Seat-Ring on Gasket (A).
- (2) Put Back-up Ring and Seal-Ring into Holder in order.
- (3) Insert Valve Plug and Stem assembly into Cage.
- (4) Install Holder onto Cage fitting to Valve Plug. Pay attention not to damage or deform the Seal-Ring.
- (5) Follow the procedure on Paragraph 5. 2. 3. 4 (1) ~ (7) for further assembly.

 CAUTION	<p>Be sure to install Seal-Ring and Back-up Ring in correct direction. If the direction is not correct, it is not possible to get good sealing. (See Fig.5-7.)</p> <p>Keep the assembling in order. If install Cage, Holder with Seal-Ring into Body first and then install Valve Plug, it is very easy to damage or deform Seat-Ring. (See Fig.5-5.)</p>
---	---

Fig.5-6 Assembling Procedure (Correct Way)

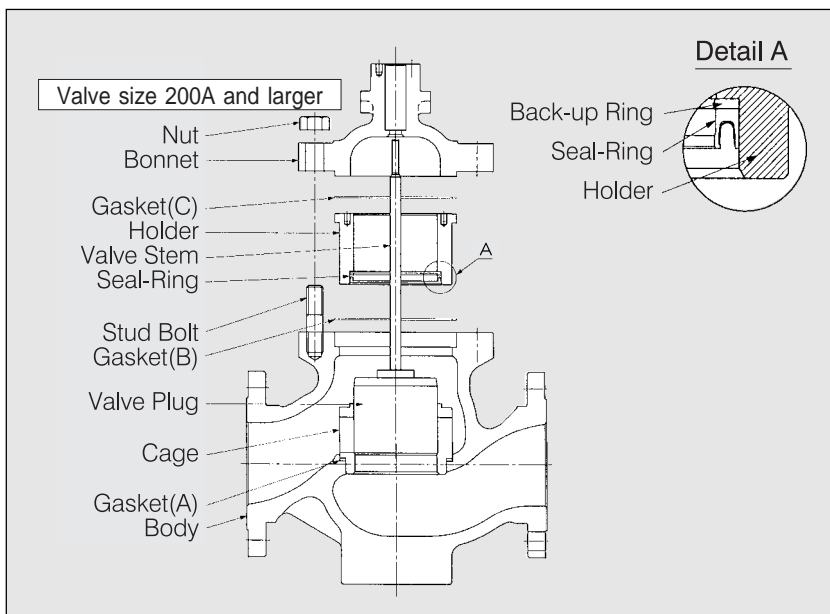

Fig.5-5 Assembling Procedure (Wrong Way)

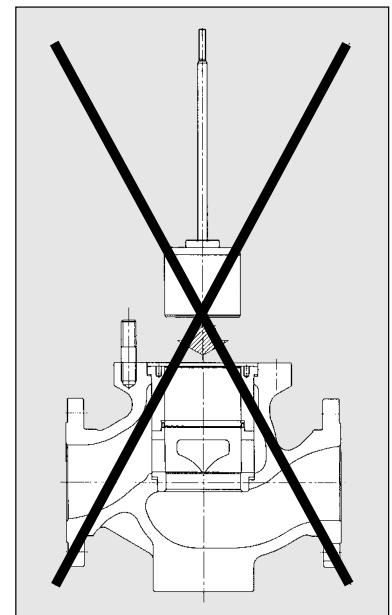
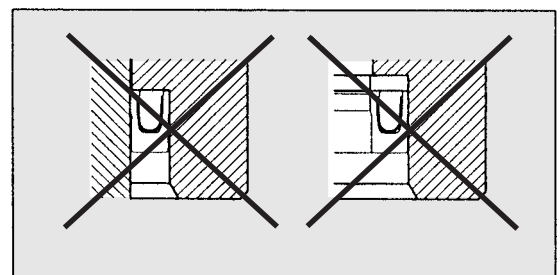
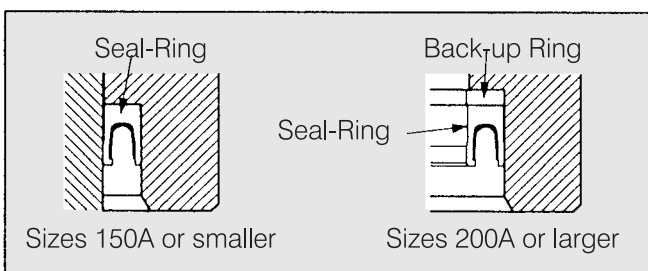



Fig.5-7 Seal Ring orientation

Correct Way orientation (Seal-Ring downward direction)

Wrong Way orientation (Seal-Ring lip upward direction)



5. 2. 3. 3 Model BSH Trim Assembling (See Fig. 5-11.)

 CAUTION	<p>On Model BSH, outer diameter of Seal-Ring is slightly larger than inner diameter of the Guide. Insert Seal-Ring alone into Guide first and be sure to fit the Seal-Ring into the Guide correctly without any gap or too loose. Also confirm the slit of Seal-Ring not to be open widely. (See Fig. 5-8.)</p>
---	---

- (1) Install Spiral Wound Gasket (A) on Body lower groove and Serrated Gasket (B) on Body upper groove. Install Seal-Ring on Gasket (A).
- (2) Install the Guide. Confirm whether Guide is fitting Cage properly.
- (3) Install Tension-Ring into the groove of Valve Plug. Then install Seal-Ring over the Tension-Ring.

 CAUTION	<p>Install the slit of Tension-Ring and the slit of Seal-Ring opposite position, 180 degree apart. If two slits are installed in closed position, sealing efficiency would be decreased. (See Fig.5-9.) When install Seal-Ring to Valve Plug, do not open the slit too much. Just open to fit outside diameter of the Valve Plug. Seal-Ring is easy to be broken if opened too much.</p>
---	--

- (4) Install Valve Plug together with Seal-Ring and Tension-Ring into Guide slowly. Pay attention not to deform Seal-Ring.

 CAUTION	<p>Seal-Ring slit is open slightly by Tension-Ring. When insert Valve Plug into Guide, close Seal-Ring slit by fingers. It may not possible to insert Valve Plug into Guide without closing Seal-Ring slit and it may damage Seal-Ring itself. (See Fig.5-10.)</p>
---	--

Please install the slit position of Seal-Ring to be rectangular against body flow direction. (See Fig. 5-12.)

- (5) Follow the procedure on Paragraph 5. 2. 3. 4 (1) ~ (7) for further assembly.

Fig.5-8 Seal-Ring Check before Assembling

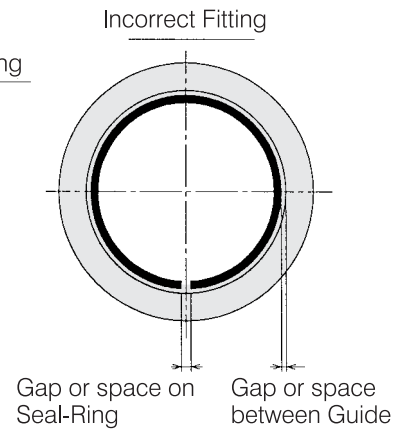
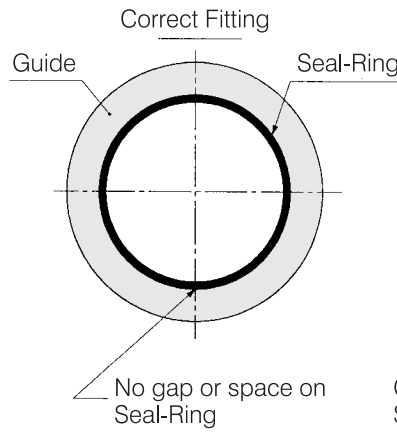
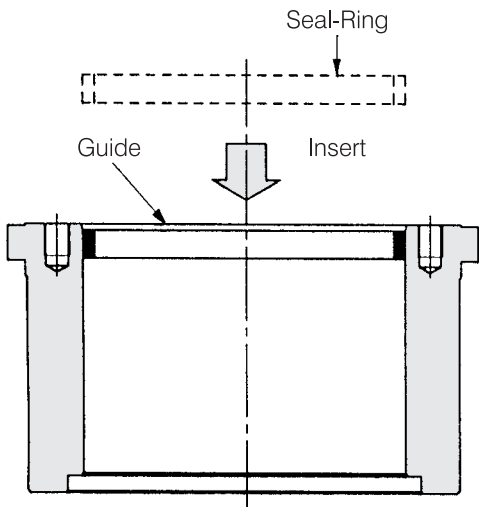

Fig.5-9 Orientation of Seal-Ring and Tension-Ring

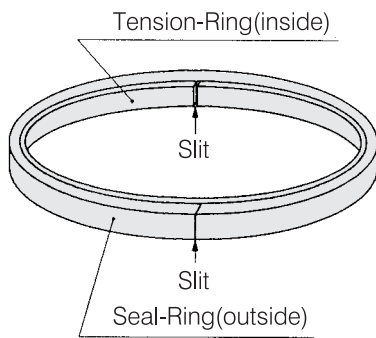

Fig.5-10 Insert of Valve Plug

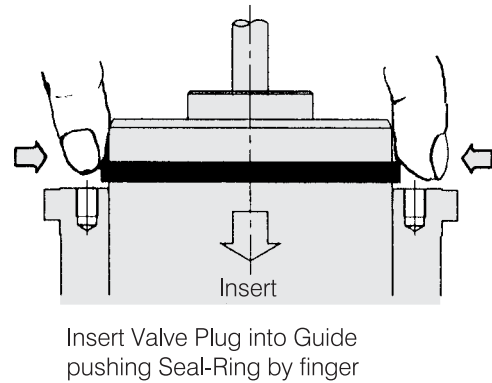

Fig.5-11 BSH Assembly procedure

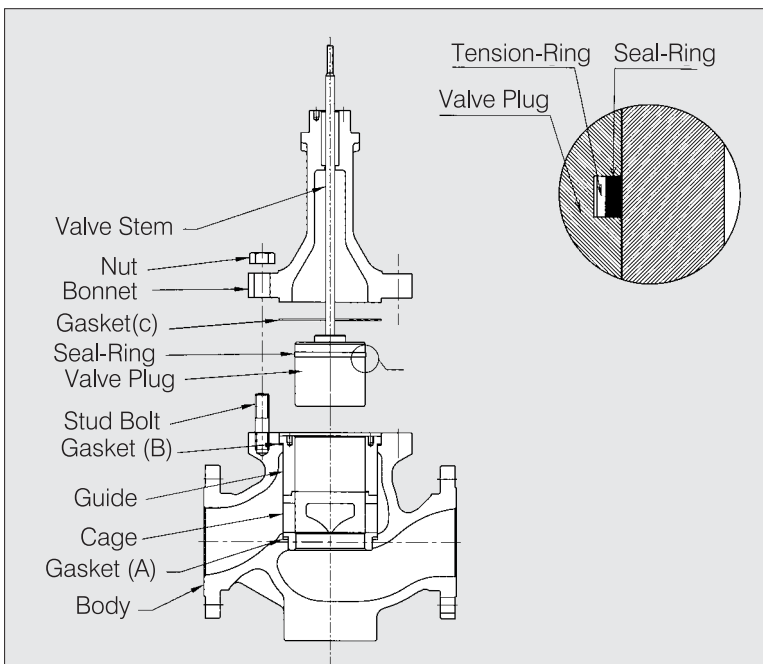
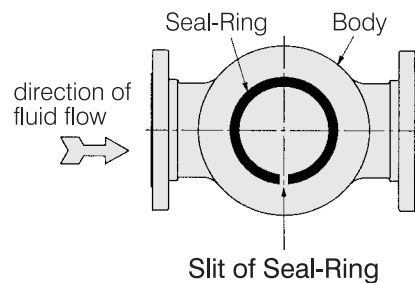

Fig.5-12 Body and Seal-Ring position



5. 2. 3. 4 Assembling of Other Parts

- (1) Install Serrated Gasket (C) on Holder (Model BS) or Guide (Model BSH) and then install Bonnet. Be sure Body, Cage, Valve Plug and Bonnet are installed correctly in straight and in concentricity.
- (2) Apply anti-seize grease on Stud Bolts and tighten Nuts slightly.
- (3) Be sure to check the smooth movement of Valve Stem up and down. Insert Gland Packing one by one into Bonnet Gland with applying grease on it. (See Fig. 5-13 and Table 4-1 on page 8) Be sure to install each Packing uniformly around the Stem. On braided Packing, each cut end should be placed opposite position, 180 degree apart.

Fig.5-13 Gland Packing

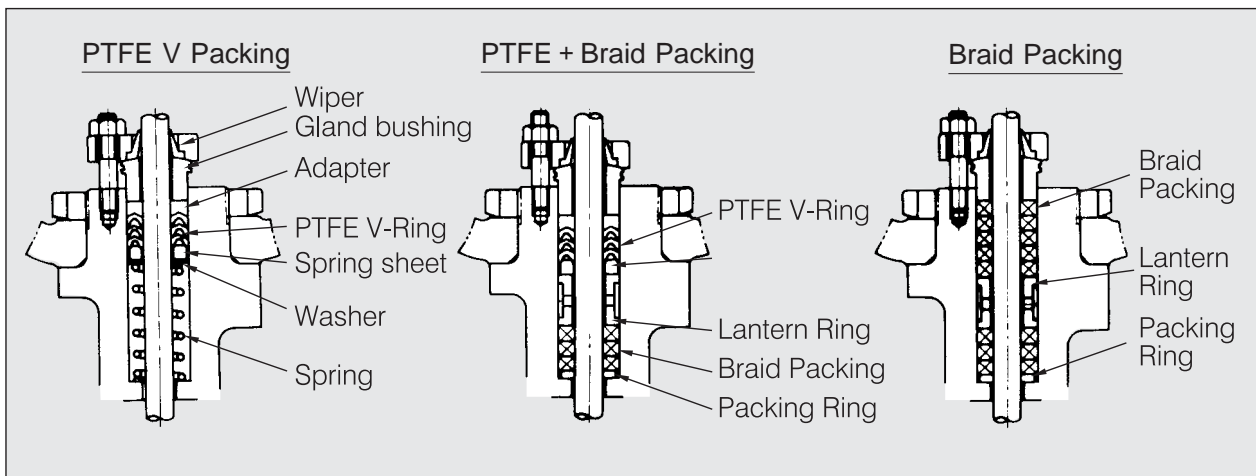

- (4) Install Gland Bushing, Wiper and Gland Flange in order. Tighten Gland Nuts alternately and uniformly. Required torque is as follows.

Unit: N-cm(kgf-cm)

Actuator size	PTFE V-Packing (+Braid Packing)	Braid Packing
N28 ~ N33S	100 ~ 500 (10 ~ 50)	200 ~ 800 (20 ~ 80)
N40 ~ 650	150 ~ 700 (15 ~ 70)	1000 ~ 2500 (100 ~ 250)

[Note] Required torque is varies depend on type of Gland Packing, service condition, temperature and pressure. This table shows standard torque for reference.

- (5) Install Stem Nuts and Pointer.
- (6) Tighten Stud Nuts alternately and uniformly.
- (7) Be sure to confirm the smooth movement of Valve Plug (Valve Stem) up and down.



CAUTION

When confirming Valve Plug movement up and down, be sure to move within the range of rated lift of the Valves.

If Plug was lifted up too much, Seal-Ring may be damaged on Model BS and Seal-Ring might be getting off from Guide on Model BSH.

Pay attention not to move too much.

When re-assembling, be sure to change all the Seal-Ring, Gland Packing, Gasket Packing and Back-up Ring (Model BS) with the new parts.

Pay attention not to damage Valve Plug sliding surface, Holder groove inner surface and new Seal-Ring on Model BS. On Model BSH, pay attention not to damage Guide sliding surface, Valve Plug groove and a new Seal-Ring.

Never apply greases onto Seal-Ring for both Model BS and Model BSH.

6 Trouble Shooting

Following is a list of general Troubles, Causes and Corrective Actions in routine operation of Control Valves.

Table 6-1 Trouble Shooting

Troubles		Presumed causes	Corrective action
Valve fails to operate.	No signal nor supply air pressure	Air pressure source (compressor) fault	Check compressor
		Large leakage on Air piping	Check Air piping
	No supply Air pressure	Clogged or leaking on Air piping	Check Air piping
		Pressure Regulator Valve fault	Check and repair pressure Regulator
	No signal Air pressure	Controller fault	Check Controller
		Clogged or leaking on signal Air piping	Check Air piping
	No Positioner output	Pilot Valve in Positioner fault	Check and repair Pilot Valve
		Large leakage on Actuator	Check Actuator (Diaphragm)
	Valve no movement even Air press is working on Actuator	Valve Stem or Guide stick	Disassemble Body and check, repair or replace
		Bend or breakage on Valve Stem	Repair or replace Valve Stem
Foreign matter entrapped on Seat or between Guide clearance.		Disassemble and Check Valve port	
Vibration or Noise	Vibration and noise in all range of opening	Large clearance between Guide and Plug	Repair or replace Valve Plug and Guide
		Loose connections (Valve Stem and Valve Plug, Valve Stem and Top Stem, Top Stem and Diaphragm).	Re-tighten connection
		Poor de-aeration of fluid	De-aerate fluid
		Flashing at outlet of the Valve Plug	Change Valve type
	Plug chatter at almost fully closed position	Fluid flow to close Valve Plug (flow close)	Change Valve Cv or Plug and Control position
	Shock waves occur at Valve outlet	Valve size too small (steam)	Enlarge Valve size
Valve fails to operate.	Supply Air pressure fluctuates	Insufficient Air source capacity	Add compressor
		Pressure Regulator fault	Repair or replace pressure Regulator Valve
	Signal Air pressure fluctuates	Inappropriate resistance or volume of Controller	Install Valve or volume tank in signal circuit
		Controller fault	Check Controller
	Neither supply Air nor signal Air pressure fluctuates, but Valve hunts	Positioner fault	Check Pilot Valve Tighten Positioner connections
		Large friction on Valve Stem	Check and repair Valve Stem and Guide
		Large friction on Gland Packing	Replace Packing
Resonance with fluids turbulent wave motion (fluctuations in stem's thrust due to changes in fluid pressure)		Reduce differential pressure Change Actuator, higher rigidity Install rectify straight pipe on upstream	

Troubles		Presumed causes	Corrective action
Too Slow Action	Too slow stroke both direction	Clogged guide with slurry or solids	Disassemble and clean Change Valve type (Angle type)
		Deteriorated and hardened gland Packing	Change Packing and grease Change Packing material
			Too slow stroke, one way
	Actuator Air volume is big	Install Positioner or booster	
	Air leakage from Actuator	Check Actuator	
	Large hysteresis error	Valve Stem and Guide, no alignment	Check Valve Stem alignment
Deteriorated and hardened gland Packing		Change Packing	
Foreign matter entrapped in Valve Plug		Disassemble and clean up	
Clogged Valve Stem or Guide with slurry or solid		Disassemble and clean up	
Loose connection of Positioner or insufficient tightening		Re-tighten and re-adjust	
Valve no move beyond certain travel	Manual handle position is not set at "NEUTRAL"	Set Handle position "NEUTRAL"	
	Lack of supply air pressure	Check supply air pressure	
Large Leakage	Valve Stem fully closed position	Corrosion, erosion or damage on Valve Seat	Check Seat and repair or lap
		Cavity in Valve Body	Repair or replace Body
		Corrosion or erosion of Gasket (A)	Change Gasket
		Abrasion deformation, damage of Seal-Ring	Change Seal-Ring
		Incorrect flow direction	Correct flow direction
	Impossible to move to fully closed position	Large differential pressure	Increase actuator power
		Foreign matter entrapped in Valve Plug	Disassemble and clean up
		Guide or port seizure	Repair or replace damaged parts
	Control position changed, range ability decreased	Corrosion or erosion of Valve Plug or Cage	Change Valve Plug or Cage
	Leakage from Gland Packing	Loose gland Nut	Re-tighten uniformly
Deteriorated and hardened Gland Packing		Change Packing. Change Packing material	
Incorrect insert of Gland Packing		Re-insert correctly	
No Grease		Add Grease	
Corrosion, erosion or damage of Valve Stem		Repair or change Valve Stem	

[Caution] If any improvement can not be made even by taking above mentioned corrective actions, Please contact our sales office for further solution.

7 Recommended Spare Parts

- (1) All the parts of Control Valves are designed and manufactured utilizing Motoyama's flow Control technology accumulated over past years. To continue stable operation of Control Valves, it is recommended that the following genuine parts should be changed periodically as recommended in Table 7-1.

Table 7-1 Overhaul Internal and Recommended Spare Parts

Component	Replacement Part	Disassembling Interval	Replacement Interval
Body	Gland Packing Gasket Packing	2years	Change the parts when disassembled. Tension-Ring (BSH Type) may not need to be changed every 2 years. (same as BP Type)
	Seal-Ring (Model BS and Model BSH) Back-up Ring (Model BS)		
Actuator	Diaphragm Daisthread [®] Daistat [®] O-Ring Seal-Packing Dust Seal	5years	Check and change when necessary.

- (2) When ordering spare parts, be sure to inform us the Parts Name and the serial numbers of the Valves which is specified on the Name Plate.

 CAUTION	<p>Be sure to use the Genuine Parts only. Also use the specified Grease described in this manual.</p> <p>MOTOYAMA has no responsibility for the troubles in-correct or imitated parts and grease were used.</p>
---	---

8 Disposal of Control Valves and Parts

 <p>WARNING</p>	<p>Be sure to blow out all the pressures and fluids left in the piping line before dismantling the Control Valves.</p> <p>When harmful fluid remains in the body of the dismantled Valve, disassemble the Body (See Para 5 on page 10) and clean up internals.</p> <p>Otherwise, human accident or environmental pollution may be induced.</p>
---	--

- (1) Basically, Control Valves component parts do not contain any harmful materials for pollution. When necessary, scrap Control Valves as general metal-discarding materials.
- (2) When there is any discarding restriction for asbestos material, check the Model number of Gland Packing and Gasket on the Name Plate, and if it is confirmed as asbestos type, take the Gasket and Gland Packing out from the Body, then, discard it separately from other metal parts.

Reference Data

Estimated Life Cycle of Control Valve Parts

Generally, estimated life cycle of Control Valves component parts are shown in following table. Whereas, the life of each parts differ by temperature, pressure, frequency or operation and environment in service. It is recommended to use this table for reference for your consideration. Accordingly, please be noted that estimated life cycle below do not mean the warranty value by MOTOYAMA. Motoyama's general warranty period for Control Valves is one (1) year after shipment.

Estimated Life Cycle of Control Valves Parts

Part	No.	Part Name	Life Cycle	Notes
Valve Body	1	Body	10years	Change Body if wall thickness decreased to 90% of designed value
	2	Bonnet	10	
	3	Valve Plug	5	Change when clearance became + 0.1 mm larger than design value
	4	Cage	5	
	5	Holder (Model BS)	5	Change when there is a change in the Seal-Ring clearance (more than + 0.05mm greater than spec)
		Guide (Model BSH)	5	
	6	Seal-Ring	2	Change on every overhaul
	7	Back-up Ring (Model BS 200mm and larger)	2	Change on every overhaul
		Tension Ring (Model BSH)	5	Change when any damage found
	8	Valve Stem	5	(Valve Plug is welded to Stem)
	9	Gland Flange	10	
	10	Stud Bolt	5	Same for Nut
	11	Gland Bolt	5	Same for Nut
	12	York Bolt, York Nut	10	
	13	Gasket	2	Change on every overhaul
	14	Wiper	5	Change when any damage or scratch found
	15	Gland Bushing	10	
	16	Gland Packing	2	Change on every overhaul
17	Lantern Ring	10		
18	Packing Ring	10		
Actuator	19	Yoke	10	
	20-1	Diaphragm Case	10	
	20-2	Diaphragm Cover	10	
	21	Diaphragm Stem	10	
	22	Diaphragm Plate	10	
	23	Diaphragm Rubber	10	Change when any damage found
	24	Spring	10	Same as above
	25	Spring Seat	10	
	26	Adjustment Screw	5	
	27	Adjustment Guide	5	
	28	Seat Bearing	5	
	29	Daistat [®] , Daisthread [®]	5	Change on every overhaul
30	Dust Seal, O-Ring, Seal-Packing	5	Same as above	

Control Valve Parts Name and Construction

Parts number on below sketch is the number of the Table "Estimated Life Cycle of Control Valve Parts", page 24.

[Note] Some parts for reverses action type are not shown on the sketch.
See page 14 for details.

【Direct Action Actuator】

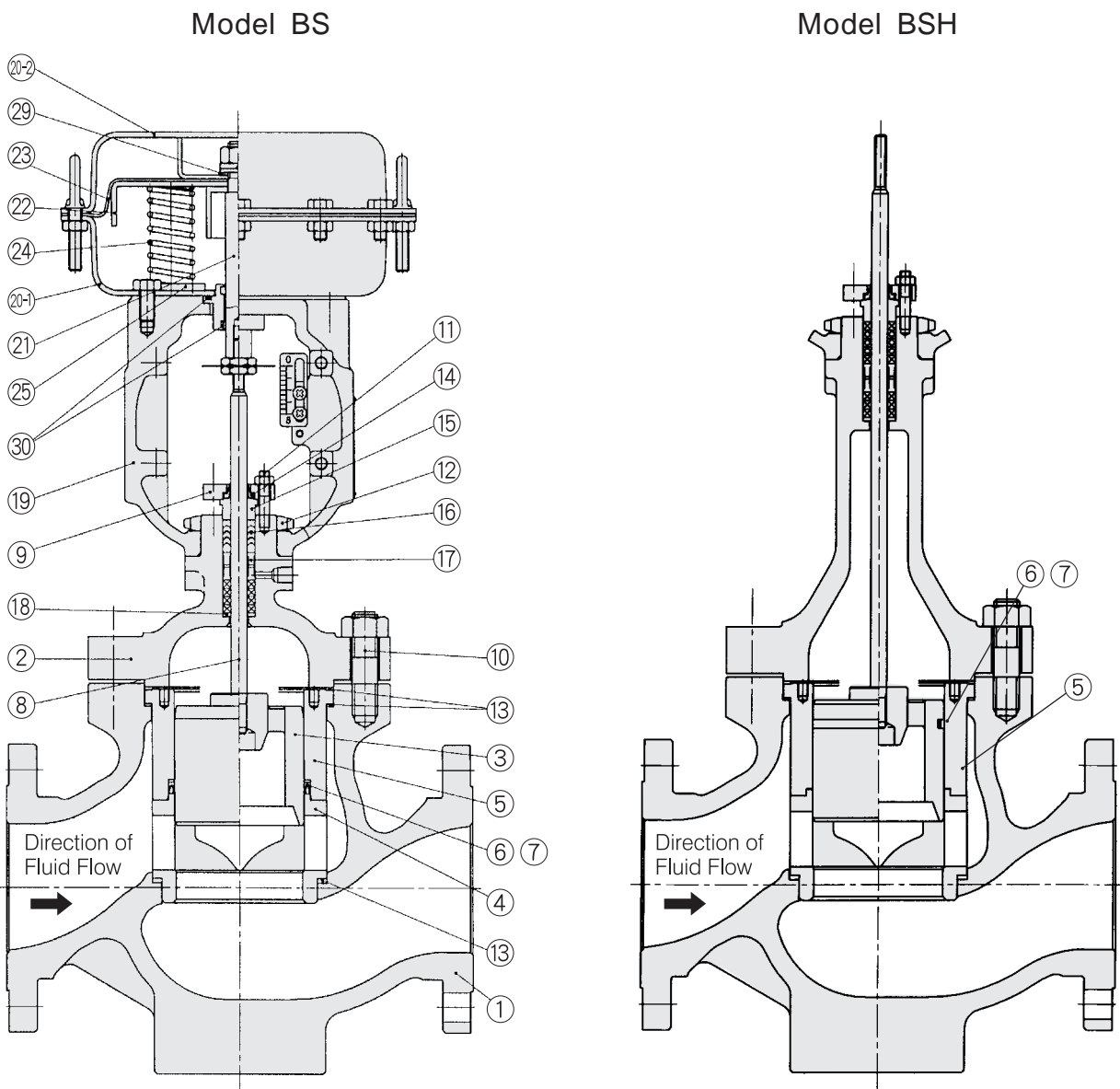

This manual is supplied for information purpose only and should not be considered certified marketability and conformability of this product.

This catalog is supplied for information purpose only and should not be considered certified marketability and conformability of this product.

MOTOYAMA is continuously improving and upgrading its product design, specifications and/or dimensions. Information included herein is subject to change without notice.

A KURIMOTO, LTD. *Company*



MOTOYAMA ENG. WORKS, LTD.

<http://www.motoyama-cp.co.jp/>

■ Head office and Factory

5-2, Ohira Aza Kameoka, Ohira-mura, Kurokawa-gun, Miyagi-ken, 981-3697 Japan

TEL: +81-22-344-4511 / FAX: +81-22-344-4522

■ Overseas Marketing & Sales Dept

5-2, Ohira Aza Kameoka, Ohira-mura, Kurokawa-gun, Miyagi-ken, 981-3697 Japan

TEL: +81-22-344-4546 / FAX: +81-22-208-5020