

# Tidbit® v2 Temp (UTBI-001) Manual



The Tidbit v2 Temp logger is Onset's smallest U-Series logger. Its durable, waterproof case is designed for extended deployments measuring temperature in streams, lakes, oceans, coastal habitats, and soils. The logger's small size allows it to be easily mounted and/or hidden in the field. It is waterproof up to 305 m (1000 feet) and rugged enough to withstand years of use. It has enough memory to record over 42,000 12-bit temperature measurements.

The logger uses an optical USB communications interface (via a compatible shuttle or base station) for launching and reading out the logger. The optical interface allows the logger to be offloaded without compromising the electronics. The USB compatibility allows for easy setup and fast downloads. HOBOWare® 2.2 or later is required for logger operation. Visit [www.onsetcomp.com](http://www.onsetcomp.com) for compatibility information.

## Tidbit v2 Temp

UTBI-001

### Required Items:

- HOBOWare 2.2 or later
- Coupler (COUPLER2-D)
- Optic USB Base Station (BASE-U-4) or HOBO Waterproof Shuttle (U-DTW-1)

### Accessories:

- Black protective boot, 5-pack (BOOT-TIDBIT-BK)
- White protective boot, 5-pack (BOOT-TIDBIT-WH)

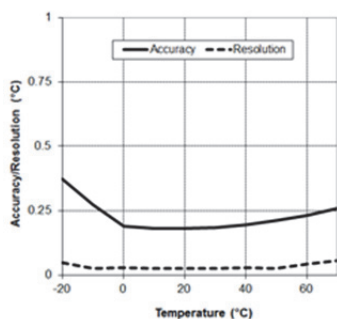

Plot A

## Specifications

### Temperature Sensor

<b>Operation Range*</b>	-20° to 70°C (-4° to 158°F) in air; maximum sustained temperature of 30°C (86°F) in water*
<b>Accuracy</b>	±0.21°C from 0° to 50°C (±0.38°F from 32° to 122°F), see Plot A
<b>Resolution</b>	0.02°C at 25°C (0.04°F at 77°F), see Plot A
<b>Response Time</b>	5 minutes in water; 12 minutes in air moving 2 m/sec; 20 minutes in air moving 1 m/sec (typical to 90%)
<b>Stability (Drift)</b>	0.1°C (0.18°F) per year

### Logger

<b>Real-time Clock</b>	±1 minute per month 0° to 50°C (32° to 122°F)
<b>Battery</b>	3 Volt lithium, non-replaceable
<b>Battery Life (Typical Use)</b>	5 years with 1 minute or greater logging interval
<b>Memory (Non-volatile)</b>	64K bytes memory (approx. 42,000 12-bit temperature measurements)
<b>Weight</b>	19.6 g (0.69 oz)
<b>Dimensions</b>	3.0 × 4.1 × 1.7 cm (1.2 × 1.6 × 0.68 in.); mounting bail 4.6 mm (3/16 in.) diameter hole
<b>Wetted Materials</b>	Epoxy case
<b>Waterproof</b>	To 305 m (1000 ft.)
<b>Logging Interval</b>	Fixed-rate or multiple logging intervals, with up to 8 user-defined logging intervals and durations; logging intervals from 1 second to 18 hours. Refer to HOBOWare software manual.
<b>Launch Modes</b>	Immediate start, delayed start, triggered start
<b>Offload Modes</b>	Offload while logging; stop and offload
<b>Battery Indication</b>	Battery level can be viewed in status screen and optionally logged in datafile. Low battery indication in datafile.
<b>NIST Certificate</b>	Available for additional charge
<b>CE</b>	The CE Marking identifies this product as complying with all relevant directives in the European Union (EU).

\* To guarantee accuracy, the Tidbit v2 Temp must not be used in condensing environments and water temperatures higher than 30C (86F) for more than eight cumulative weeks over the life of the logger. Frequent or prolonged exposure will lead to measurement drift and eventual failure.

## Connecting the Logger

1. Install the logger software on your computer before proceeding.
2. Follow the instructions that came with your base station or shuttle to attach the base station or shuttle to a USB port on the computer.
3. Wipe the logger with a nonabrasive cloth, if necessary, to ensure that the logger's communication LEDs are clean and dry.
4. Attach the coupler to the base station, then insert the logger into the coupler with the communication LEDs facing into the coupler, as shown in the diagram.

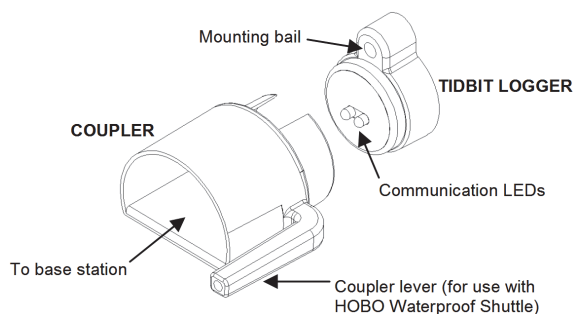

When properly seated, the logger should be nearly flush with the top of the coupler.

5. If you are using the HOBO Waterproof Shuttle, briefly press the coupler lever to put the shuttle into base station mode.
6. If the logger has never been connected to the computer before, it may take a few seconds for the new hardware to be detected by the computer.
7. Use the logger software to launch the logger, check the logger's status, read it out, stop it manually with the software, or let it record data until the memory is full. Or, use the HOBO Waterproof Shuttle to read out and relaunch the logger in the field.

Refer to the software user's guide for complete details on launching, reading out, and viewing data from the logger.

**Important:** USB communications may not function properly at temperatures below 0°C (32°F) or above 50°C (122°F).

**Note:** The logger consumes significantly more battery power when it is "awake" and connected to a base station or shuttle. To conserve power, the logger will go into a low-power (sleep) mode if there has been no communication with your computer for 30 minutes. To wake up the logger, remove the logger from the coupler, wait a moment, then re-insert the logger.

**Note:** The first time you launch the logger, the deployment number will be greater than zero. Onset launches the loggers to test them prior to shipping.

## Operation

An "OK" light (LED) on the front of the logger confirms logger operation. (In brightly lit areas, it may be necessary to shade the logger to see the "OK" light blink.) The following table explains when the "OK" light blinks during logger operation:

When:	The light:
The logger is logging	Blinks once every one to four seconds (the shorter the logging interval, the faster the light blinks); blinks when logging a sample
The logger is awaiting a start because it was configured to start logging At Interval, On Date/Time, or Using Coupler	Blinks once every eight seconds until logging begins

## Triggered Launch

The Tidbit v2 Temp has an optional triggered launch. Launch your logger choosing the Using Coupler option. The magnetically operated reed switch is activated when the Tidbit Coupler is reconnected to the logger for 2 seconds and then removed. The base station and coupler are not necessary to trigger the launch. Any strong magnet placed near the face of the logger will trigger the launch. The Tidbit v2 Temp's red LED light will rapidly flash four times to indicate successful triggered launch.

## Sample and Event Logging

The logger can record two types of data: samples and events. Samples are the sensor measurements recorded at each logging

interval (for example, temperature every minute). Events are independent occurrences triggered by a logger activity, such as Bad Battery or Host Connected. Events help you determine what was happening while the logger was logging.

The logger stores 64K of data, and can record over 42,000 12-bit temperature measurements.

## Deploying and Protecting the Logger

- Depending on water conditions and desired measurement location, the logger should be appropriately weighted, secured, and protected.
- The mounting bail on the logger accepts 1/8 inch (4 mm) diameter nylon cord or other strong cable. If wire is used to secure the logger, make sure the wire loop is snug to the bail. Any slack in the loop may cause excessive wear.
- This logger should not be immersed in any liquid other than fresh or salt water. To do so may damage the epoxy case and void the warranty (refer to the Service and Support section). If you have any questions about chemical resistance, call Onset.
- To clean the logger, rinse it in warm water. Use a mild dishwashing detergent if necessary. Do not use harsh chemicals, solvents, or abrasives, especially on the communications LEDs.

## Battery

The battery in the Tidbit v2 Temp is a non-replaceable 3-Volt lithium battery. The battery life of the logger should be about five years. Actual battery life is a function of the number of deployments, logging interval, and operation/storage temperature of the logger. To obtain a five-year battery life, a logging interval of one minute or greater should be used and the logger should be operated and stored at temperatures between 0° and 25°C (32° and 77°F). Frequent deployments with logging intervals of less than one minute, and continuous storage/operation at temperatures above 35°C, will result in significantly lower battery life. For example, continuous logging at a one-second logging interval will result in a battery life of approximately one month.

The logger can report and log the battery voltage. If the battery falls below 2.7 V, the logger will record a "bad battery" event in the datafile. If the battery fails, dispose of the logger according to local regulations. Do not attempt to open the logger case. The battery is not replaceable, and the logger does not contain any user-serviceable parts. If you open the case, the logger will be unusable, and the warranty will be voided.

**⚠ WARNING:** Do not cut open, incinerate, heat above 100°C (212°F), or recharge the lithium battery. The battery may explode if the logger is exposed to extreme heat or conditions that could damage or destroy the battery case. Do not dispose of the logger or battery in fire. Do not expose the contents of the battery to water. Dispose of the battery according to local regulations for lithium batteries.