

**COMET SYSTEM**

---

**[www.cometsystem.com](http://www.cometsystem.com)**

**Web Sensor P8510**

**Web Sensor P8511**

**Web Sensor P8541**

**USER GUIDE**

**© Copyright: COMET System, s.r.o.**

Is prohibited to copy and make any changes in this manual, without explicit agreement of company COMET System, s.r.o. All rights reserved.

COMET System, s.r.o. makes constant development and improvement of their products. Manufacturer reserves the right to make technical changes to the device without previous notice. Misprints reserved.

Manufacturer is not responsible for damages caused by using the device in conflict with this manual. To damages caused by using the device in conflict with this manual cannot be provide free repairs during the warranty period.

This user manual describes device with firmware version **4-5-8.x**. Manuals for older firmware version are available via technical support.

# Table of contents

Introduction.....	4
General safety rules .....	4
Device description and important notices.....	5
Getting started.....	6
What is needed for operation .....	6
Mounting the device.....	6
Device settings .....	8
Checking functions.....	10
Device setup .....	11
Setup using web interface.....	11
Setup using TSensor software .....	18
Factory defaults.....	18
Communication protocols .....	20
Website.....	20
SMTP – sending e-mails.....	20
SNMP .....	21
Modbus TCP.....	22
SOAP.....	24
Syslog.....	25
SNTP.....	26
Troubleshooting.....	27
I forgot the device IP address.....	27
I cannot connect to the device .....	27
Error or n/a is displayed instead the measured value .....	28
Error2 is displayed on all channels instead the measured value.....	28
I forgot the password for setup.....	28
Factory defaults.....	28
Technical specifications .....	29
Dimensions.....	29
Basic parameters .....	30
Operating terms .....	32
End of operation .....	32
Technical support and service .....	33
Preventive maintenance.....	33
Optional accessories.....	34

## Introduction

*This chapter provides basic information about device. Before starting please read this manual carefully.*

Thermometer Web Sensor P8510 or Web Sensor P8511 and Web Sensor P8541 are used to measure temperature or relative humidity. Temperature can be displayed in °C or °F. Relative humidity have unit %RH. Communication with the device is realized via Ethernet network.

Thermometer Web Sensor P8510 has compact design and measures the temperature in place of installation. Web Sensor P8511 is designed to connect one probe. To Web Sensor P8541 is possible connect up to four probes. Temperature or humidity probes are available as optional accessories.

## General safety rules

*The following summary is used to reduce the risk of injury or damage the device. To prevent injury, please follow instructions in this manual.*



The device can be services only by a qualified person. The device contains no serviceable parts inside.

Don't use the device, if it doesn't work correctly. If you think, that the device is not working correctly, let check it by qualified service person.

It's forbidden to use the device without the cover. Inside the device can be a dangerous voltage and may be risk of electric shock.

Use only the appropriate power supply adapter according to manufacturer specifications and approved according to relevant standards. Make sure, that the adapter does not have damaged cables or covers.

Connect the device only to network parts approved according to relevant standards.

Connect and disconnect the device properly. Don't connect or disconnect Ethernet cable or probes, if the device is powered.

The device may be installed only in prescribed areas. Never expose the device to higher or lower temperatures than is allowed. The device has not improved resistance to moisture. Protect it from dripping or splashing water and do not use at areas with condensation.

Don't use device in potentially explosive environments.

Don't stress the device mechanically.

## Device description and important notices

*This chapter contains information about basic features. Also there are important notices concerning to functional safety.*

Values from the device can be read using an Ethernet connection. The following formats are supported:

- Web pages with user changeable look and XML files
- Modbus TCP protocol
- SNMPv1 protocol
- SOAP protocol

The device can also be used to check measured values and if the limit is exceeded, device sends warning messages. Possible ways to sending warning messages:

- Sending e-mails up to 3 e-mail addresses
- Sending SNMP traps up to 3 configurable IP addresses
- Displaying the alarm status on web page
- Sending messages to Syslog server

The device setup can be made by the TSensor software or web interface. TSensor software can be free downloaded from the manufacturer's website. Also you will find there latest firmware for your device. Do not upload to your device firmware which is not designed for it. Unsupported firmware can damage your device.

Device does not support powering over Ethernet cable (PoE). PoE splitter must be used. Compatible PoE splitter can be purchased as optional accessories. Splitter must have 5V output with approximately 1W.



Reliability of warning messages delivering (e-mail, trap, syslog), depends on actual availability of necessary network services. The device should not be used for critical applications, where malfunction could cause to injury or loss of human life. For highly reliable systems, redundancy is essential. For more information please see standard IEC 61508.



Never connect the device directly to the Internet. If it is necessary connect the device to the Internet, properly configured firewall must be used. Firewall can be partially replaced with the NAT.

## Getting started

*Here you can find information necessary to put newly purchased equipment to operation. This procedure is only informative.*

### What is needed for operation

To install the unit you need to the following equipment. Before installation check if it's available.

- Web Sensor P8510 or Web Sensor P8511, P8541
- power supply adapter 5V/250mA (or compatible PoE splitter)
- RJ45 LAN connection with appropriate cable
- free IP address in your network
- for Web Sensor P8511 one probe. For Web Sensor P8541 up to 4 temperatures probes type DSTR162/C, DSTGL40/C, DSTG8/C or relative humidity probe DSRH

### Mounting the device

- check if the equipment from previous chapter are available
- install the latest version of TSensor software. This software is used to all device settings. TSensor software can be free downloaded from the manufacturer's website. Software can be also supplied on CD. Device configuration can be made using web interface. For web configuration is not TSensor software necessary.
- contact your network administrator to obtain following information for the connection to the network:

IP address:	_____
Gateway:	_____
DNS server IP:	_____
Netmask:	_____

## IE-SNC-P85x1-15

- check if there is no IP address conflict when you connect the device into network for the first time. The device has from factory set the IP address to **192.168.1.213**. This address must be changed according to information from the previous point. When you installing several new devices, connect them to the network one after another.
- connect probes to Web Sensor P8511 or Web Sensor P8541
- connect the Ethernet connector
- connect the power adapter 5V/250mA
- LEDs on LAN connector should blink after connecting the power

Web Sensor P8510 connection:

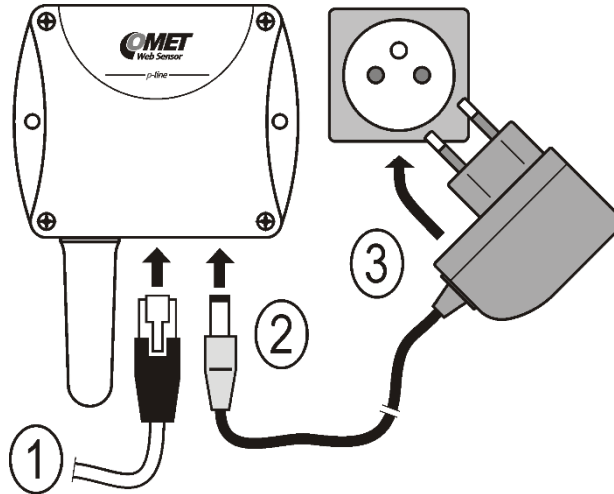

Web Sensor P8511 connection:

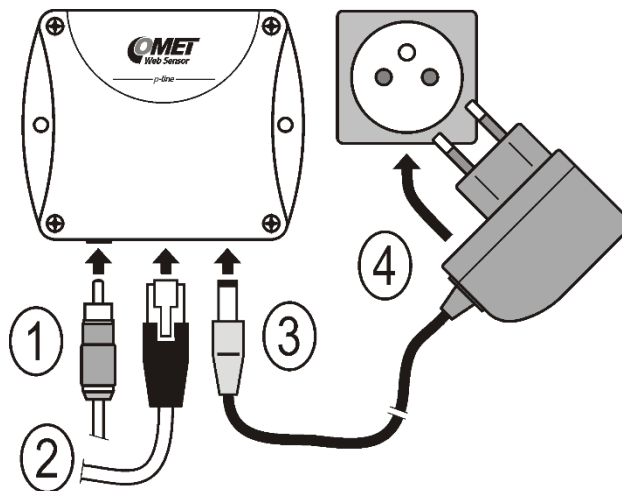

Web Sensor P8541 connection:

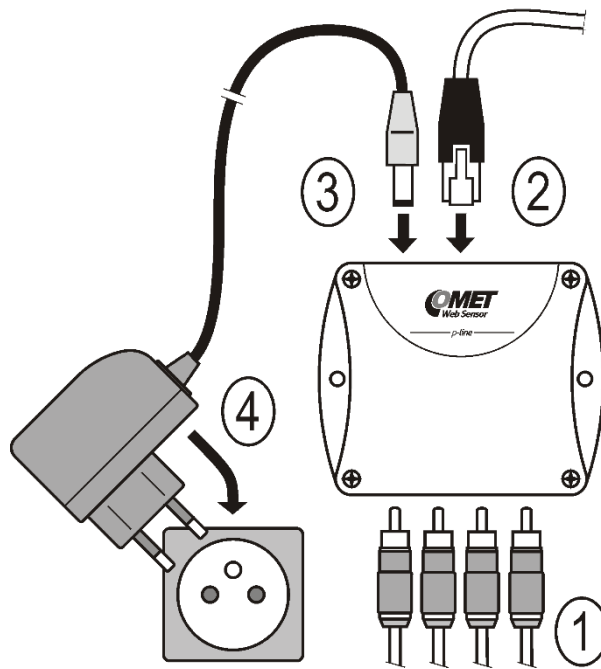

Connect via PoE splitter:

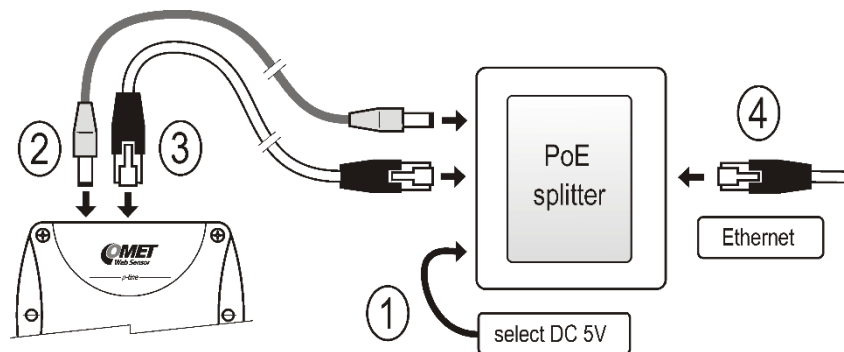

## Device settings

- run configuration software TSensor on your PC
- switch to an **Ethernet** communication interface
- press button **Find device...**

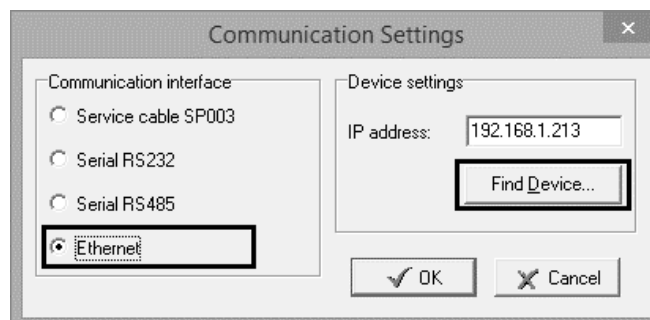



- the window shows all available devices on your network

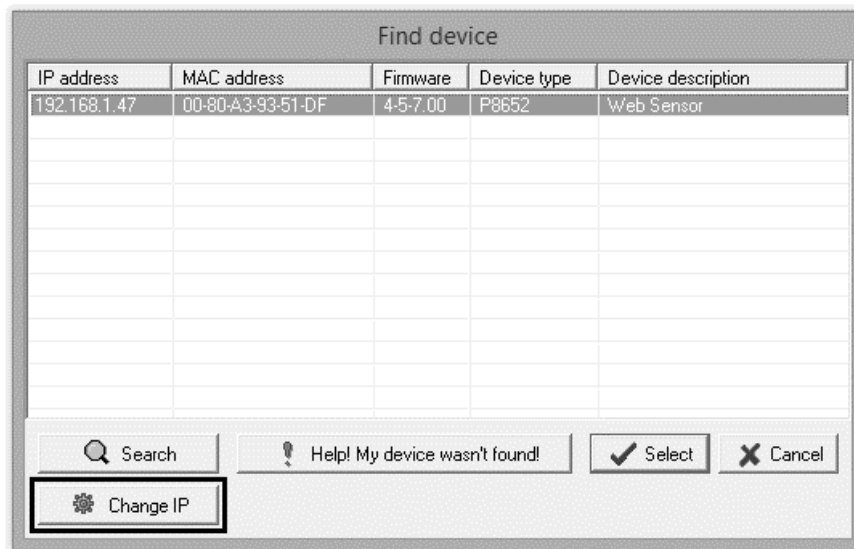

- click to **Change IP address** to set new address according to network administrator instructions. If your device is not listed, then click **Help! My device wasn't found!** Then follow the instructions. MAC address is on product label. The device is factory set to IP **192.168.1.213**.

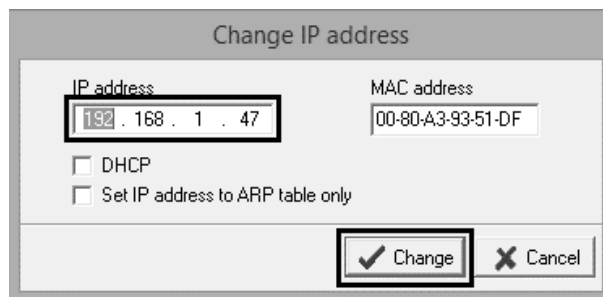

- gateway may not be entered if you want to use the device only in local network. If you set the same IP address which is already used, the device will not work correctly and there will be collisions on the network. If the device detects a collision of IP address then reboot is performed automatically.
- after changing IP address device is restarted and new IP address is assigned. Restart of the device takes about 10 seconds.
- connect to device using TSensor software and check the measured values. If Web Sensor P8511 or Web Sensor P8541 values are not displayed, it's necessary to find probes using button **Search probes (Find probes)**.
- set the other parameters (alarm limits, SMTP server, etc.). Settings are saved after click on button **Save changes**.

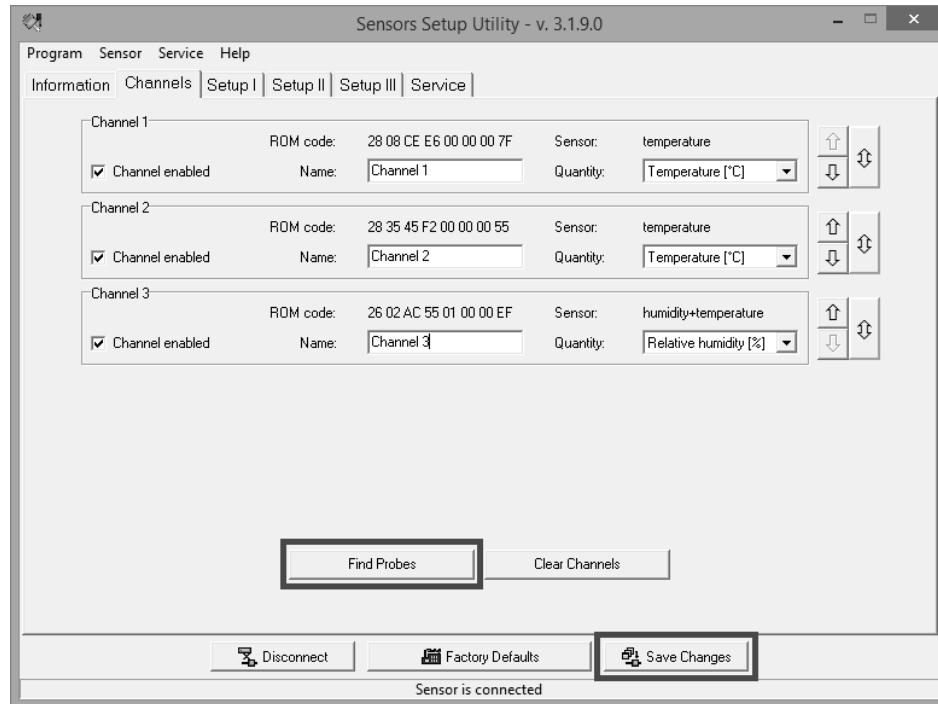

## Checking functions

The last step is to check measured values on the device website. Enter the device IP address into address bar of the web browser. If the default IP address was not changed, then insert **http://192.168.1.213**.

Displayed web page lists actual measured values. If the web pages are disabled, you can see text **Access denied**. If the measured value exceeds the measurement range or probe is not correctly installed, then is shown **Error** message. If the channel is switched off, the web site displayed **n/a** instead of the value.

## Device setup

*This chapter describes basic device configuration. There is a description of settings using web interface.*

### Setup using web interface

Device can be setup using web interface or TSensor software. Web interface can be managed by the web browser. Main page will be shown when you insert device address into address bar of your web browser. There you find actual measured values. Page with history graphs is shown when you click to tile with actual values. Access to device setup is possible via tile **Settings**.

The screenshot shows a web browser window with the address bar containing '192.168.213'. The page title is 'Web Sensor' and the URL is '192.168.213'. The page displays the following information:

- Web Sensor** (s/n: 14969090) Time: 12:15:59 2015-03-11
- Channel 1**: 34.1%RH, alarm none, min: 25.3%RH, max: 34.7%RH
- Channel 2**: 32.9%RH, alarm none, min: 25.3%RH, max: 33.7%RH
- Channel 3**: 26.1°C, alarm none, min: 19.6°C, max: 27.6°C
- Channel 4**: 33.4%RH, alarm none, min: 27.3%RH, max: 33.9%RH
- History** (dot file, comma file)
- Events** (dot file, comma file)
- MinMax mem**
- Events viewer**
- Mobile web**
- Settings** (marked with an asterisk \*)
- About** (marked with a question mark ?)

Copyright © 2015, Comet system s.r.o. All rights reserved.

## General

Device name can be changed using item **Device name**. Measured values are stored into memory according **History storage interval** field. After changing of this interval all history values will be cleared. Changes must be confirmed by **Apply settings** button.

## Network

Network parameters can be obtain automatically from DHCP server using option **Obtain an IP address automatically**. Static IP address is configurable via field **IP address**. It is not necessary setup **Default gateway** while you use device inside one subnet only. **DNS server IP** is required to set for proper function of DNS. Option **Standard subnet mask** sets network mask automatically according A, B or C network class. **Subnet mask** field must be set manually, when network with non-standard range is used. **Periodic restart interval** enables to restart device after selected time since device start.

## Alarm limits

For each measurement channel is possible to set upper and lower limits, time-delay for alarm activation and hysteresis for alarm clearing.

**Back**  
Exit to main menu

**Settings**

**General**  
General device settings

**Network**  
Basic settings of the network interface

**Alarm limits**  
Configuration of the alarm limits

**Channels**  
General settings of the channels

**MinMax memory**  
Timestamps, clear memory

**Maintenance**  
Factory defaults, info, etc.

### Alarm limits

Configuration of the alarm limits. The safe range is between high and low limit. Alarm condition occurs while measured value is out of the safe range for selected time delay. Alarm is cleared if measured value returns to safe range with hysteresis.

**Channel 1 limits**  
Channel name: Channel 1  
Current value: 22.8 °C  
User adjustment: no

High limit [°C]	Low limit [°C]	Hysteresis [°C]	Time delay [sec]
50.0	0.0	1.0	30

**Channel 2 limits**  
Channel name: Channel 2  
Current value: 48.7 %RH  
User adjustment: no

High limit [%RH]	Low limit [%RH]	Hysteresis [%RH]	Time delay [sec]
50.0	0.0	1.0	30

Example of setting the limit to the upper alarm limit:

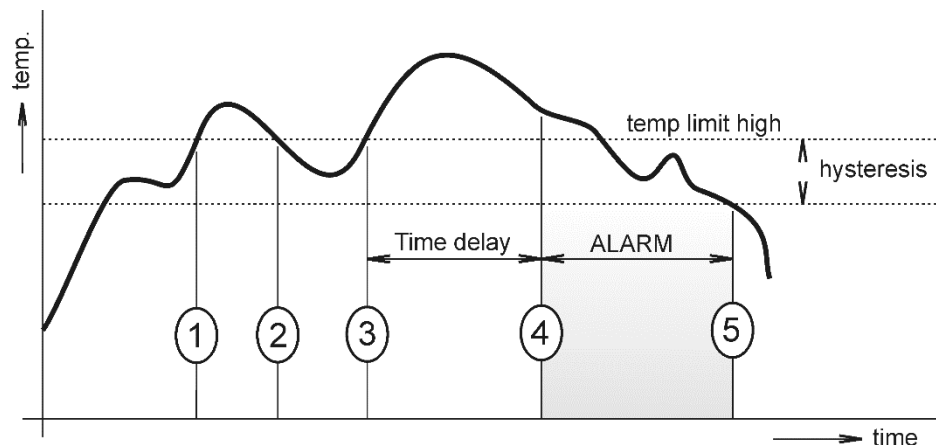

In Point 1 the temperature exceeded the limit. From this time, the time-delay is counting. Because at point 2 the temperature dropped below the limit value before the time delay expired, alarm was not set.

In Point 3 the temperature has risen over limit again. During the time-delay the value does not drop below the set limit, and therefore was in Point 4 caused alarm. At this moment were sent e-mails, traps and set alarm flag on website, SNMP and Modbus.

The alarm lasted up to Point 5, when the temperature dropped below the set hysteresis (temperature limit – hysteresis). At this moment was active alarm cleared and e-mail send.

When alarm occurs, alarm messages will be sent. In case of power failure or device reset (e.g. changing the configuration) will new alarm state evaluated and new alarm messages will be send.

## Channels

Channel can be enabled or disabled for measuring using item **Enabled**. Channel can be renamed (max. 14 characters) and it is possible select unit of measured value according connected probe type. When channel is not used, it is possible copy to it one of other channels – option **Clone channel**. This option is not available at fully occupied device. **Find sensors** button starts searching for connected probes. All changes must be confirmed using **Apply settings** button. History values are cleared after changing of channel settings.

**Settings Channels**

General settings of the channels. Find sensors button starts search for connected probes. Connected probes can be cloned to unused channels. To change order of ROM codes Drag and Drop feature can be used. History values of the channel will be cleared immediately after changing channel settings.

**Channel 1**  
ROM code: 28 23 00 E7 00 00 00 3E  
Sensor: temperature probe

Enabled Channel 1 temperature [°C]

**Channel 2**  
ROM code: 26 6E 90 53 01 00 00 FD  
Sensor: humidity+temperature probe

Enabled Channel 2 humidity [%RH]

Apply settings Find sensors Clear channels Cancel changes

## SOAP protocol

SOAP protocol can be enabled by option **SOAP protocol enabled**. Destination SOAP server can be set via **SOAP server address**. For setup of server port can be used option **SOAP server port**. Device sends SOAP message according selected **Sending interval**. Option **Send SOAP message when alarm occurs** sends message when an alarm on channel occurs or alarm is cleared. These SOAP messages are sent asynchronously to selected interval.

**Settings SOAP**

Setup SOAP protocol for database system. Current measured values are sent as XML files. For more information please read the user guide for database system.

SOAP protocol enabled

SOAP server address http://192.168.1.132/soap

SOAP server port 80

Sending interval 20 Sec

Send SOAP message when alarm occurs

Apply settings Cancel changes

## Email

**Email sending enabled** option allows email features. It is necessary set address of the SMTP server into **SMTP server address** field. Domain name for SMTP server can be used. Default port of the SMTP server can be changed using item **SMTP server port**. SMTP authentication can be enabled using **SMTP authentication** option. When authentication is enabled **Username** and **Password** must be set.

For successfully email sending it is necessary insert **Email sender address**. This address is usually same as username of the SMTP authentication. Into fields **Recipient 1** to **Recipient 3** it is possible set address of email recipients. Option **Short email** enable sending emails in short format. This format is usable when you need to forward emails into SMS messages.

When option **Alarm email repeat sending interval** is enabled and there is active alarm on channel, then emails with actual values are sent repeatedly. **Info email sending interval** option enables sending emails at selected time interval. CSV history file can be sent together with the repeat/info emails. This feature can be enabled by **Alarm and Info emails attachment** option.

It is possible to test email function using button **Apply and test**. This button save a new settings and send a testing email immediately.

<b>General</b> General device settings	Configuration of the alarm emails. Device can send warning email when alarm on measured channel occurs. Email is also sent when alarm condition is cleared.	
<b>Network</b> Basic settings of the network interface	Email sending enabled	<input checked="" type="checkbox"/>
<b>Alarm limits</b> Configuration of the alarm limits	<b>SMTP server configuration</b> For proper email sending it is necessary to setup connection to your SMTP server. SMTP authentication can be used if needed. For information about SMTP server settings please contact your network administrator or ISP.	
<b>Channels</b> General settings of the channels	SMTP server address	<input type="text" value="smtp.example.com"/>
<b>SOAP protocol</b> Setup SOAP protocol for database system	SMTP server port	<input type="text" value="25"/>
<b>Email</b> Alarm emails configuration	SMTP authentication	<input checked="" type="checkbox"/>
<b>Protocols</b> Syslog and ModbusTCP protocol settings	Username	<input type="text" value="sensor@example.com"/>
<b>SNMP</b> SNMPv1 protocol and SNMP Traps	Password	<input type="password" value="••••••••"/>
<b>Time</b> Synchronization with NTP server	<b>Email configuration</b> Setup up to three address for email recipients. Sender address is usually the same as the username of the SMTP authentication.	
<b>WWW and Security</b> Web server and Security configuration	Email sender address	<input type="text" value="sensor@example.com"/>
<b>MinMax memory</b> Timestamps, clear memory	Recipient 1	<input type="text" value="admin@gmail.com"/>
<b>Maintenance</b> Factory defaults, info, etc.	Recipient 2	<input type="text" value="jara.cimrman@live.com"/>
	Recipient 3	<input type="text"/>
	Short email	<input type="checkbox"/>
	Alarm email repeat sending interval	<input type="text" value="1 Hour"/>
	Info email sending interval	<input type="text" value="1 Day"/>
	Alarm and Info emails attachment	<input type="text" value="Comma CSV files"/>
	<input type="button" value="Apply settings"/> <input type="button" value="Apply and test"/> <input type="button" value="Cancel changes"/>	

## Modbus a Syslog protocols

ModbusTCP and Syslog protocol settings are configurable via menu **Protocols**. Modbus server is enabled by default. Deactivation is possible via **Modbus server enabled** option. Modbus port can be changed via **Modbus port** field. Syslog protocol can be enabled using item **Syslog enabled**. Syslog messages are sent to IP address of the Syslog server - field **Syslog server IP address**.

**Settings Protocols**

**General**  
General device settings

**Network**  
Basic settings of the network interface

**Email**  
Alarm emails configuration

**Protocols**  
Syslog and ModbusTCP protocol settings

**SNMP**  
SNMPv1 protocol and SNMP Traps

**Time**  
Synchronization with NTP server

**ModbusTCP protocol**  
Configuration of the ModbusTCP protocol. Current measured values can be read using ModbusTCP protocol. Modbus registers are described inside the user manual.

Modbus server enabled

Modbus port

**Syslog protocol**  
Configuration of the Syslog protocol. Alarm messages can be sent to the Syslog server using UDP protocol.

Syslog enabled

Syslog server IP address

Apply settings Cancel changes

## SNMP

For reading values via SNMP it is necessary to know password - **SNMP read community**. SNMP Trap can be delivered up to three IP address - **IP address of the Trap recipient**. SNMP Traps are sent at alarm or error state on the channel. Trap feature can be enabled by option **Trap enabled**.

**Settings SNMP**

**General**  
General device settings

**Network**  
Basic settings of the network interface

**Protocols**  
Syslog and ModbusTCP protocol settings

**SNMP**  
SNMPv1 protocol and SNMP Traps

**Time**  
Synchronization with NTP server

**WWW and Security**  
Web server and Security configuration

Configuration of the SNMPv1 protocol and SNMP Traps. Current measured values can be read using SNMP protocol. When alarm on channel occurs a warning message (Trap) can be sent to selected IP addresses.

SNMP read community

System location

Trap enabled

IP address of the Trap recipient 1

IP address of the Trap recipient 2

IP address of the Trap recipient 3

Apply settings Cancel changes



## Time

Time synchronization with SNTP server can be enabled by **Time synchronization enabled** option. IP address of the SNTP is necessary to set into **SNTP server IP address** item. List of free NTP servers is available at [www.pool.ntp.org/en](http://www.pool.ntp.org/en). SNTP time is synchronized at UTC format, and due to be necessary set corresponding time offset - **GMT offset [min]**. Time is synchronized every 24 hours by default. Option **NTP synchronization every hour** decrease this synchronization interval to one hour.

The screenshot shows the 'Settings' menu with 'Time' selected. The left sidebar contains: Back (Exit to main menu), General (General device settings), Network (Basic settings of the network interface), SNMP (SNMPv1 protocol and SNMP Traps), Time (Synchronization with NTP server), WWW and Security (Web server and Security configuration), and MinMax memory (Timestamps, clear memory). The main content area is titled 'Time' and includes a note: 'Time can be synchronized according the SNTP server. To correct time is necessary set GMT offset of your time zone. Time synchronisation is required for timestamps inside CSV files.' The configuration options are: 'Time synchronised with server' (yes (at 15:48:10 2015-02-17)), 'Time synchronization enabled' (checked), 'SNTP server IP address' (192.168.1.2), 'GMT offset [min]' (60), and 'NTP synchronization every hour' (unchecked). At the bottom are 'Apply settings' and 'Cancel changes' buttons.

## WWW and security

Security features can be enabled by the **Security enabled** option. When security is enabled it is necessary to set administrator password. This password will be required for device settings. When secured access is required even to actual values reading it is possible to enable **User account only for viewing**. Port of the www server can be changed from the default value 80 using filed **WWW port**. Web pages with actual values are refreshed according to **Web refresh interval** field.

The screenshot shows the 'Settings' menu with 'WWW and Security' selected. The left sidebar contains: Back (Exit to main menu), General (General device settings), Network (Basic settings of the network interface), Time (Synchronization with NTP server), WWW and Security (Web server and Security configuration), MinMax memory (Timestamps, clear memory), and Maintenance (Factory defaults, info, etc.). The main content area is titled 'WWW and Security' and includes a note: 'Configuration of the secure access to the device. Administrator password must be inserted if security is enabled. Administrator password is used for device configuration. User password is used only for measured values viewing.' The configuration options are: 'Security enabled' (unchecked), 'Web server enabled' (checked), 'WWW port' (80), and 'Web refresh interval' (10 Sec). At the bottom are 'Apply settings' and 'Cancel changes' buttons.

## Setup using TSensor software

TSensor software is an alternative to web configuration. Some less important parameters are configurable only by the TSensor software.

Parameter **MTU size** can reduce size of the Ethernet frame. Lowering of this size can solve some communication problems mainly with Cisco network infrastructure. Sensor software can set offset of values at temperature probes. At DSRH humidity probe is possible set correction of the humidity and temperature.

## Factory defaults

**Factory defaults** button set the device into factory configuration. Network parameters (IP address, Subnet mask, Gateway, DNS) are left without changes.

The screenshot shows a web interface with a top navigation bar containing 'Back Exit to main menu', 'Settings', and 'Maintenance'. The left sidebar lists various settings categories: General, Network, Alarm limits, Channels, SOAP protocol, Email, Protocols, SNMP, Time, WWW and Security, MinMax memory, and Maintenance. The main content area is divided into two columns. The right column contains an 'Info' section with device details, an 'Events Logs' section with buttons for 'Alarm events log', 'System events log', and 'Clear events logs', a 'Restart' section with a 'Restart device' button, and a 'Factory defaults' section with a 'Factory defaults' button.

Info	
Device type	P8652
Serial number	07940143
MAC address	00-80-A3-93-4E-3F
Firmware version	4-5-6-0.3307 / 1.50
Build firmware notice	BETA_1
Device uptime	2 h, 21 min, 29 sec
Diagnostic file	<a href="#">192.168.1.47/diag.log</a>

**Events Logs**  
Events logs with the system or alarm messages can be downloaded in CSV file format for further analysis. After request confirmation both logs are cleared together.

**Restart**  
Device will be restarted after dialog confirmation. All history values are cleared after restart. Restarting of the device will take a few seconds.

**Factory defaults**  
Factory defaults button restores device to factory settings. Network parameters like a IP address, subnet mask and gateway IP will not be changed.

Network parameters are changed while you close jumper inside the device. After jumper closing it is necessary connect power supply. Factory defaults have no effect to user correction inside probe.

Factory parameters settings:

Parameter	Value
SMTP server address	example.com
SMTP server port	25
Alarm email repeat sending interval	off
Info email repeat sending interval	off
Repeat email attachment	off
E-mail recipients addresses	cleared
E-mail sender	sensor@IP
SMTP authentication	off
SMTP user/SMTP password	cleared
E-mail sending enabled	off
IP addresses SNMP traps recipients	0.0.0.0
System location	cleared
Password for SNMP reading	public
Sending SNMP Trap	off
Website refresh interval [sec]	10
Website enabled	yes
Website port	80
Security	off
Administrator password	cleared
User password	cleared
Modbus TCP protocol port	502
Modbus TCP enabled	yes
History storage interval [sec]	60
SOAP message when alarm occurs	yes
SOAP destination port	80
SOAP server address	cleared
SOAP sending interval [sec]	60
SOAP protocol enabled	off
Syslog server IP address	0.0.0.0
Syslog protocol enabled	off
SNTP server IP address	0.0.0.0
GMT offset [min]	0
NTP synchronization every hour	off
SNTP synchronization enabled	off
MTU	1400
Periodic restart interval	off
Demo mode	off
Turn on all channels	yes
Upper limit	50
Lower limit	0
Hysteresis – hysteresis for alarm clearing	1
Delay – time-delay of alarm activation [sec]	30
Channel enabled	all channels
Unit on the channel	°C or %RH according used probe
Channel name	Channel X (where X is 1 to 5)
Device name	Web sensor

## Communication protocols

*Short introduction to communication protocols of the device. To use some communication protocols is necessary software, which can use the protocol. This software is not included.*

### Website

The device supports displaying of measured values, history graphs and configuration using web browser. History graphs are based on HTML5 canvas. Web browser must support this feature for proper function of graphs. Firefox, Opera, Chrome or Internet Explorer 9 can be used. If the device has IP address **192.168.1.213** type into your browser **http://192.168.1.213**. Using TSensor software or web interface can be set automatic webpages refresh in interval. The default value is 10sec. Actual measured values can be obtained using XML file **values.xml**.

Values from history can be exported in CSV format. History storage interval can be set using TSensor software or web interface. History is erased after every reboot of the device. Reboot of the device is performed when the power supply is disconnected and also after configuration change.

The device allows you to customize the design of web pages. Details of how to change the design, you can find in the manual appendix. Manual appendix can be obtained from the manufacturer's website.

### SMTP – sending e-mails

When measured values are over the set limits, the device allows send e-mail to a maximum of 3 addresses. E-mail is send when alarm condition on the channel is cleared or a measuring error occurs. It is possible to set repeat interval for email sending. For correct sending of e-mails it is necessary to set address of SMTP server. Domain address can be used as SMTP server address too. For proper function of DNS is required to set DNS server IP address. SMTP authentication is supported but SSL/STARTTLS not. Standard SMTP port 25 is used by default. SMTP port can be changed. Contact your network administrator to obtain configuration parameters of your SMTP server. E-mail sent by the device cannot be answered.

## SNMP

Using SNMP protocol you can read actual measured values, alarm status and alarm parameters. Via SNMP protocol is also possible to get last 1000 measured values from history table. Writing via SNMP protocol is not supported. It is supported **SNMPv1** protocol version only. SNMP used **UDP port 161**. OID keys description can be found in the MIB table, which can be obtained from device website or from your distributor. The password for reading is factory set to **public**. Filed **System location** (OID 1.3.6.1.2.1.1.6 - sysLocation) is blank by default. The changes can be made using web interface. Some SNMP manager software requires add .0 at end of OID key (e.g.: 1.3.6.1.4.1.22626.1.5.2.1.2.0). OID keys:

OID	Description	Type
.1.3.6.1.4.1.22626.1.5.1	Device information	
.1.3.6.1.4.1.22626.1.5.1.1	Device name	String
.1.3.6.1.4.1.22626.1.5.1.2	Serial number	String
.1.3.6.1.4.1.22626.1.5.1.3	Device type	Integer
.1.3.6.1.4.1.22626.1.5.2.ch	Measured value (where ch is channel number)	
.1.3.6.1.4.1.22626.1.5.2.ch.1	Channel name	String
.1.3.6.1.4.1.22626.1.5.2.ch.2	Actual value – text	String
.1.3.6.1.4.1.22626.1.5.2.ch.3	Actual value	Int*10
.1.3.6.1.4.1.22626.1.5.2.ch.4	Alarm on channel (0/1/2)	Integer
.1.3.6.1.4.1.22626.1.5.2.ch.5	High limit	Int*10
.1.3.6.1.4.1.22626.1.5.2.ch.6	Low limit	Int*10
.1.3.6.1.4.1.22626.1.5.2.ch.7	Hysteresis	Int*10
.1.3.6.1.4.1.22626.1.5.2.ch.8	Delay	Integer
.1.3.6.1.4.1.22626.1.5.2.ch.9	Unit	String
.1.3.6.1.4.1.22626.1.5.2.ch.10	Alarm on channel – text	String
.1.3.6.1.4.1.22626.1.5.2.ch.11	Minimal value on channel	String
.1.3.6.1.4.1.22626.1.5.2.ch.12	Maximal value on channel	String
.1.3.6.1.4.1.22626.1.5.3.1.0	SNMP Trap text	String
.1.3.6.1.4.1.22626.1.5.4.1.1.ch.nr	History table value	Int*10

When alarm occurred a warning messages (trap) can be sent to selected IP addresses. Addresses can be set using TSensor software or web interface. Traps are sent via **UDP** protocol on **port 162**. The device can send following traps:

Trap	Description	
0/0	Reset of the device	
6/0	Testing Trap	
6/1	NTP synchronization error	
6/2	E-mail sending error	SMTP server login error
6/3		SMTP authentication error
6/4		Some error occurred during SMTP communication
6/5		TCP connection to server cannot be opened
6/6		SMTP server DNS error
6/7	SOAP message sending error	SOAP file not found inside web memory
6/8		MAC address can't be obtained from address
6/9		TCP connection to server cannot be opened
6/10		Wrong response code from the SOAP server
6/11 – 6/15	Upper alarm on channel	
6/21 – 6/25	Lower alarm on channel	
6/31 – 6/35	Clearing alarm on channel	
6/41 – 6/45	Measuring error	

## Modbus TCP

Device supports Modbus protocol for communication with SCADA systems. Device use Modbus TCP protocol. **TCP port** is set to **502** by default. Port can be changed using TSensor software or web interface. Only two Modbus clients can be connected to device at one moment. Modbus device address (Unit Identifier) can be arbitrary. Modbus write command is not supported. Specification and description of the Modbus protocol is free to download on: [www.modbus.org](http://www.modbus.org).

Supported Modbus commands (functions):

Command	Code	Description
Read Holding Register (s)	0x03	Read 16b register(s)
Read Input Register(s)	0x04	Read 16b register(s)

Modbus device registers. Address could be by 1 higher, depending on type used communication library:

Address [DEC]	Address [HEX]	Value	Type
39970	0x9C22	1st two digits from serial number	BCD
39971	0x9C23	2nd two digits from serial number	BCD
39972	0x9C24	3rd two digits from serial number	BCD
39973	0x9C25	4th two digits from serial number	BCD
39974	0x9C26	Device type	uInt
39975 – 39978	0x9C27 – 0x09C2A	Actual measured value on channel	Int*10
39980 – 39983	0x9C2C – 0x9C2F	Unit on the channel	Ascii
39985 – 39988	0x9C31 – 0x9C34	Channel alarm state	uInt
39990 – 39999	0x9C36 – 0x9C3F	Unused	n/a
40000	0x9C40	Channel 1 temperature	Int*10
40001	0x9C41	Channel 1 alarm status	Ascii
40002	0x9C42	Channel 1 upper limit	Int*10
40003	0x9C43	Channel 1 lower limit	Int*10
40004	0x9C44	Channel 1 hysteresis	Int*10
40005	0x9C45	Channel 1 delay	uInt
40006	0x9C46	Channel 2 temperature	Int*10
40007	0x9C47	Channel 2 alarm status	Ascii
40008	0x9C48	Channel 2 upper limit	Int*10
40009	0x9C49	Channel 2 lower limit	Int*10
40010	0x9C4A	Channel 2 hysteresis	Int*10
40011	0x9C4B	Channel 2 delay	uInt
40012	0x9C4C	Channel 3 temperature	Int*10
40013	0x9C4D	Channel 3 alarm status	Ascii
40014	0x9C4E	Channel 3 upper limit	Int*10
40015	0x9C4F	Channel 3 lower limit	Int*10
40016	0x9C50	Channel 3 hysteresis	Int*10
40017	0x9C51	Channel 3 delay	uInt
40018	0x9C52	Channel 4 temperature	Int*10
40019	0x9C53	Channel 4 alarm status	Ascii
40020	0x9C54	Channel 4 upper limit	Int*10
40021	0x9C55	Channel 4 lower limit	Int*10
40022	0x9C56	Channel 4 hysteresis	Int*10
40023	0x9C57	Channel 4 delay	uInt

Description:

Int*10	registry is in format integer*10 – 16 bits
uInt	registry range is 0-65535
Ascii	character
BCD	registry is coded as BCD
n/a	item is not defined, should be read

Possible alarm states:

no	no alarm
lo	value is lower than set limit
hi	value is higher than set limit

## SOAP

The device allows you to send currently measured values via **SOAP v1.1** protocol. The device sends values in XML format to the web server. The advantage of this protocol is that communication is initialized by the device side. Due to it is not necessary use port forwarding. If the SOAP message cannot be delivered, warning message via SNMP Trap or Syslog protocol is sent. The file with the XSD schema can be downloaded from: <http://cometsystem.cz/schemas/soapP8xxx.xsd>. SOAP message example:

```
Host: 192.168.1.132
Content-Type: text/xml; charset=utf-8
Content-Length: 751
SOAPAction: "http://tempuri.org/InsertP8xxxSample"

<?xml version="1.0" encoding="utf-8"?>
<soap:Envelope xmlns:soap="http://schemas.xmlsoap.org/soap/envelope/"
xmlns:xsi="http://www.w3.org/2001/XMLSchema-instance"
xmlns:xsd="http://www.w3.org/2001/XMLSchema">
  <soap:Body>
    <InsertP8xxxSample xmlns="http://cometsystem.cz/schemas/soapP8xxx.xsd">

      <name>Ethernet Transducer</name>
      <sn>11940986</sn>
      <tmr>60</tmr>
      <kind>4353</kind>

      <c1>
        <v>26.3</v>
        <u>C</u>
        <a>no</a>
        <e>1</e>
      </c1>

      ...
      ...
      ...

      <c5>
        <v>-11000</v>
        <u>n/a</u>
        <a>no</a>
        <e>0</e>
      </c5>

    </InsertP8xxxSample>
  </soap:Body>
</soap:Envelope>
```



Element	Description	
<name>	Device description.	
<sn>	Contains the device serial number (an eight digit number).	
<tmr>	SOAP sending interval [sec].	
<kind>	Device type identification number (code):	
	<b>Device</b>	<b>Device</b>
	P8511	4352
	P8541	4353
	P8510	4354
<v>	Actual measured value (a decimal part of number is separated by a dot). Error on channel is signaled by number <b>-11000</b> or lower.	
<u>	Channel unit. In case of error <b>n/a</b> text is shown.	
<a>	Alarm state, where <b>no</b> – no alarm, <b>hi</b> – high alarm, <b>lo</b> – low alarm.	
<e>	Information about enabled/disabled channel ( <b>1</b> – enabled/ <b>0</b> – disabled)	

Example of the web service for incoming SOAP messages from Web Sensor P85xx. Example uses Apache (2.2.10) web server and PHP (5.2.6). It is required to install and enable SOAP extension for PHP. This example store incoming messages to the hard drive:

```
<?
function InsertP8xxxSample($name, $sn, $tmr, $kind, $c1, $c2, $c3, $c4, $c5) {
    $val1 = "NULL";
    $val2 = "NULL";
    $val3 = "NULL";
    $val4 = "NULL";
    if ($c1->e == "1") $val1 = $c1->v;
    if ($c2->e == "1") $val2 = $c2->v;
    if ($c3->e == "1") $val3 = $c3->v;
    if ($c4->e == "1") $val4 = $c4->v;
    $data = "Time: ".strftime("%y/%m/%d %H:%M:%S", Time()).", CH1: ".$val1.
        ", CH2: ".$val2.", CH3: ".$val3.", CH4: ".$val4."\n";
    $file_write = fopen("soap.log", "a");
    fwrite($file_write, $data);
    fclose($file_write);
}
$server = new SoapServer(null, array('uri' => "http://test-uri/"));
$server->addFunction('InsertP8xxxSample');
$server->handle();
?>
```

## Syslog

The device allows sending text message to selected Syslog server. Events are send using **UDP** protocol on **port 514**. Syslog protocol implantation is according to RFC5424 and RFC5426. Events when Syslog messages are send:

Text	Event
Sensor - fw 4-5-8.x	Reset of the device
NTP synchronization error	NTP synchronization error
Testing message	Test Syslog message
Email login error	E-mail sending error
Email auth error	
Email some error	
Email socket error	
Email dns error	
SOAP file not found	SOAP message sending error
SOAP host error	
SOAP sock error	
SOAP delivery error	
SOAP dns error	
High alarm CHx	Upper alarm on channel
Low alarm CHx	Lower alarm on channel
Clearing CHx	Clearing alarm on channel
Error CHx	Measuring error

## SNTP

The device allows time synchronization with NTP (SNTP) server. SNMP protocol version 3.0 is supported (RFC1305). Time synchronization is made every 24 hours. Time synchronization every hour can be enabled. For time synchronization it is necessary set IP address to the SNTP server. It is also possible set GMT offset for correct time zone. Time is used in graphs and history CSV files. Maximum jitter between two time synchronization is 90sec at 24 hours interval.

## Troubleshooting

*The chapter describes the common problems with thermometer Web Sensor P8510, Web Sensor P8511 and Web Sensor P8541 and methods how to fix these problems. Please read this chapter before you will call technical support.*

### I forgot the device IP address

IP address is factory set to **192.168.1.213**. If you had changed it and forgot new IP address, run the TSensor software and press **Find device...** In the window are displayed all available devices.

### I cannot connect to the device

#### In search window is only IP and MAC address displayed

Other details are marked **N/A**. This problem occurs if IP address of the device is set to another network.

Select the window **Find device** in TSensor software and press **Change IP address**. Follow the software instructions. To assign IP address automatically using DHCP server, set the device IP address to **0.0.0.0**.

#### Device IP address is not displayed in window Find device

In TSensor software menu press **Help! My device was not found!** in window **Find device**. Follow the software instructions. MAC address of the device can be found on product label.

#### The device is not found even after manually setting MAC address

This problem occurs especially in cases when the IP address of the device belongs to another network and also Subnet mask or Gateway are incorrect.

In this case is DHCP server in the network necessary. In TSensor software menu press **Help! My device was not found!** in window **Find device**. As new IP address set **0.0.0.0**. Follow the software instructions. An alternative is to reset device to factory defaults using factory-defaults jumper.

## Error or n/a is displayed instead the measured value

Value **n/a** is shown a shortly after device restart. If the error code or **n/a** is displayed permanently, check if the probes are connected to device correctly. Make sure that probes are not damaged and inside operating range. Than perform new search of probes using TSensor software or web interface.

## Error2 is displayed on all channels instead the measured value

**Error2** indicates short-circuit of measurement bus. Check if correct probes are connected. Probes Pt100/Pt1000/Ni100/Ni1000 cannot be used with this device. Make sure that cables of probes are not damaged.

## I forgot the password for setup

Please reset device to factory defaults. Procedure is described at following point.

## Factory defaults

This procedure restore device to factory settings including network parameters (IP address, Subnet mask, etc.). For factory-defaults follow these steps:

- disconnect the power supply
- unscrew upper cover of the device case
- close the jumper and connect the power
- keep jumper closed for 10sec then remove jumper

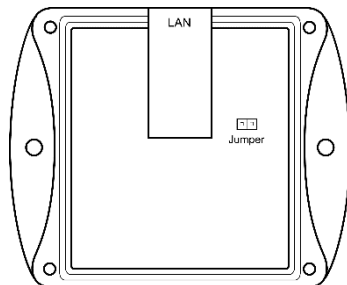

- close the device

## Technical specifications

*Information about technical specifications of the device.*

### Dimensions

Web Sensor P8510:

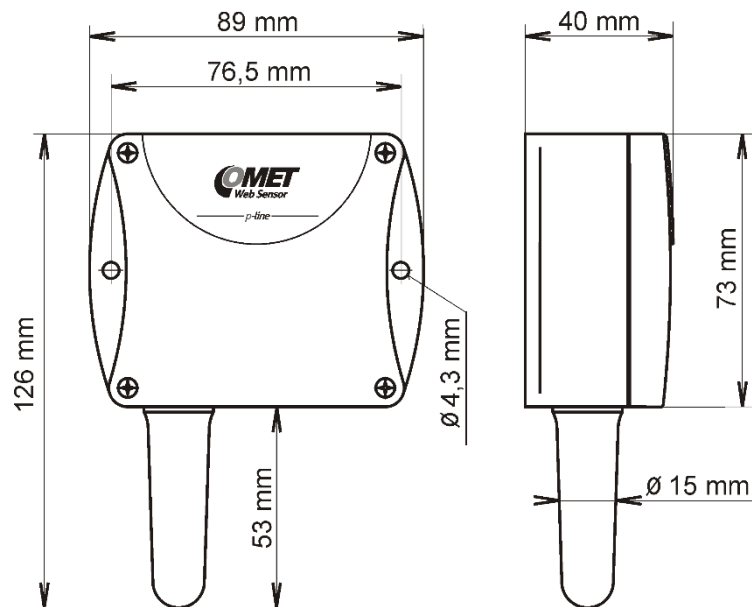

Web Sensor P8511:

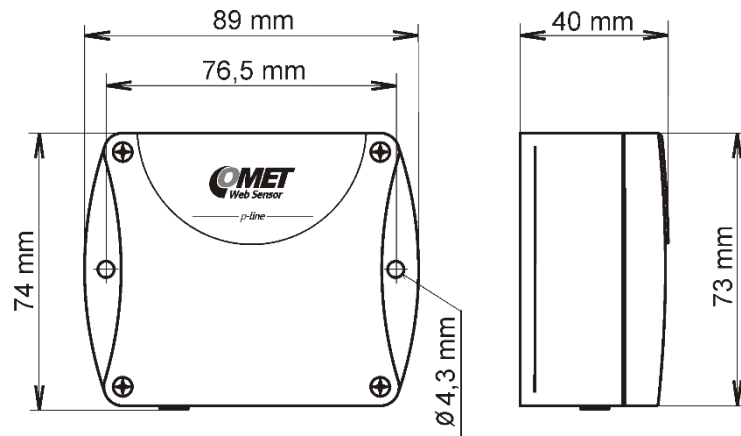

Web Sensor P8541:

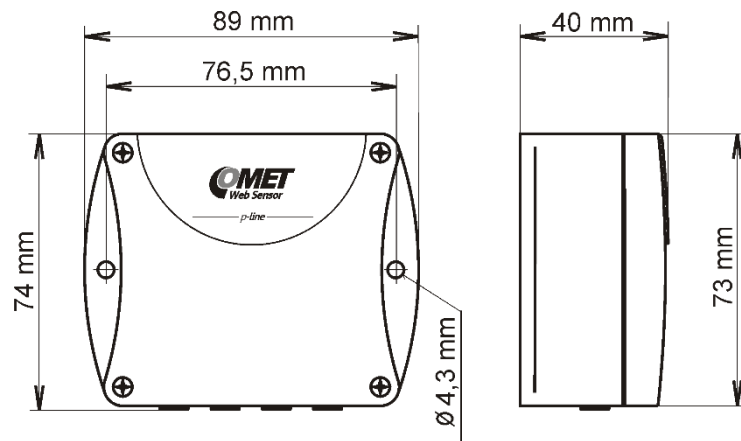

## Basic parameters

Supply voltage:

DC voltage from 4.9V to 6.1V, coaxial connector, 5x 2.1mm diameter, positive pole in the middle, min. 250mA

Consumption:

~ 1W depending on the operating mode

Protection:

IP30 case with electronic

Measuring interval:

2sec

Accuracy P8510:

$\pm 0.8^{\circ}\text{C}$  in temperature range from  $-10^{\circ}\text{C}$  to  $+80^{\circ}\text{C}$

$\pm 2.0^{\circ}\text{C}$  in temperature range from  $-10^{\circ}\text{C}$  to  $-30^{\circ}\text{C}$

Accuracy P8511, P8541 (depending on used probe – e.g. probe DSTG8/C parameters):

$\pm 0.5^{\circ}\text{C}$  in temperature range from  $-10^{\circ}\text{C}$  to  $+85^{\circ}\text{C}$

$\pm 2.0^{\circ}\text{C}$  in temperature range from  $-10^{\circ}\text{C}$  to  $-50^{\circ}\text{C}$

$\pm 2.0^{\circ}\text{C}$  in temperature range from  $+85^{\circ}\text{C}$  to  $+100^{\circ}\text{C}$

Resolution:

$0.1^{\circ}\text{C}$

0.1%RH

P8510 temperature measurement range:

$-30^{\circ}\text{C}$  to  $+80^{\circ}\text{C}$

P8511 and P8541 temperature measurement range (limited by range of used probe):

$-55^{\circ}\text{C}$  to  $+100^{\circ}\text{C}$

Recommended probe for P8511 and P8541:

Temperature probe DSTR162/C max. length 10m

Temperature probe DSTGL40/C max. length 10m

Temperature probe DSTG8/C max. length 10m

Humidity probe DSRH max. length 5m

Number of channels:

P8510 one internal temperature sensor (1 measurement channel)

P8511 one cinch/RCA connector (2 measurement channels)

P8541 four cinch/RCA connectors (4 measurement channels)

Communication port:

RJ45 connector, 10Base-T/100Base-TX Ethernet (Auto-Sensing)

Recommended Connector Cable:

for industrial use is recommended Cat5e STP cable, in less demanding applications can be replaced by Cat5 cable, maximum cable length 100m

Supported protocols:

TCP/IP, UDP/IP, ARP, ICMP, DHCP, TFTP, DNS

HTTP, SMTP, SNMPv1, ModbusTCP, SNTP, SOAPv1.1, Syslog

SMTP protocol:

SMTP authentication – AUTH LOGIN

Encryption (SSL/TLS/STARTTLS) is not supported

Supported web browsers:

Internet Explorer 9 and later, Mozilla Firefox 30 and later, Google Chrome 36 and later, Opera 21 and later. Device should be also compatible with other browsers. Functionality wasn't tested with other web browsers.

Recommended minimum screen resolution:

1024 x 768

Memory:

1000 values for each channel inside non-backup RAM memory

100 values in alarm events log inside non-backup RAM memory

100 values in system events log inside non-backup RAM memory

Case material:

ABS

Mounting the device:

With two holes at the bottom of the unit

Weight:

P8510 ~ 130g, P8511 ~ 125g, P8511 ~ 135g

EMC emission:

EN 55022, Class B

EMC resistance:

EN 61000-4-2, levels 4/8kV, Class A

EN 61000-4-3, intensity of electromagnetic field 3V/m, Class A

EN 61000-4-4, levels 1/0.5kV, Class A

EN 61000-4-6, intensity of electromagnetic field 3V/m, Class A

## **Operating terms**

Temperature and humidity range in case with electronic:

-30°C to +80°C, 0 to 100%RH (no condensation)

Temperature range of recommended probe DSTR162/C for P8511 and P8541:

-30°C to +80°C, IP67

Temperature range of probe DSTGL40/C for P8511 and P8541:

-30°C to +80°C, IP67

Temperature range of probe DSTG8/C for P8511 and P8541:

-50°C to +100°C, IP67

Temperature and humidity range of probe DSRH for P8511 and P8541:

0°C to +50°C, 10 to 90%RH

P8510 working position:

with sensor cover downwards. When mounting in RACK 19" with universal holder MP046 (accessories) then sensor cover can be placed horizontally.

P8511 and P8541 working position:

arbitrary

## **End of operation**



Disconnect the device and dispose it according to current legislation for dealing with electronic equipment. Electronic devices must be professionally destroyed in accordance with EU Directive 2002/96/ES of 27th January 2003.



## **Technical support and service**

Technical support and service is provided by distributor. Contact is included in warranty certificate.

## **Preventive maintenance**

Make sure the cables and probes are not damaged periodically. Recommended calibration interval is 2 years. Recommended calibration interval for device with humidity probe DSRH is 1 year.

## Optional accessories

*This chapter contains list of optional accessories, which can be ordered by extra cost. Manufacturer recommends using only original accessories.*

### Temperature probe DSTR162/C

Temperature probe -30 to +80°C with a digital sensor DS18B20 and with Cinch connector for Web Sensor P8511 and Web Sensor P8541. Accuracy  $\pm 0.5^{\circ}\text{C}$  from -10 to +80°C,  $\pm 2^{\circ}\text{C}$  below -10°C. Length of the plastic case 25mm, diameter 10mm. Guaranteed watertight (IP67), sensor connected to PVC cable with lengths 1, 2, 5 or 10m.

### Temperature probe DSTGL40/C

Temperature probe -30 to +80°C with a digital sensor DS18B20 and with Cinch connector for Web Sensor P8511 and Web Sensor P8541. Accuracy  $\pm 0.5^{\circ}\text{C}$  from -10 to +80°C,  $\pm 2^{\circ}\text{C}$  below -10°C. Steel steel case with length 40mm, diameter 5.7mm. Stainless steel type 17240. Guaranteed watertight (IP67), sensor connected to PVC cable with lengths 1, 2, 5 or 10m.

### Temperature probe DSTG8/C

Temperature probe -50 to +100°C with a digital sensor DS18B20 and with Cinch connector for Web Sensor P8511 and Web Sensor P8541. Maximum temperature of the probe is 125°C. Probe accuracy  $\pm 0.5^{\circ}\text{C}$  from -10 to +85°C, else  $\pm 2^{\circ}\text{C}$ . Steel steel case with length 40mm, diameter 5.7mm. Stainless steel type 17240. Guaranteed watertight (IP67), sensor connected to silicone cable with lengths 1, 2, 5 or 10m.

### Humidity probe DSRH

DSRH is a relative humidity probe with Cinch connector for Web Sensor P8511 and Web Sensor P8541. Relative humidity accuracy is  $\pm 3.5\%RH$  from 10%-90%RH at 25°C. Temperature measuring accuracy is  $\pm 2^{\circ}\text{C}$ . Operating temperature range is 0 to +50°C. Probe length 88mm, diameter 18mm, connected to PVC cable with lengths 1, 2 or 5m.

### Humidity-temperature probe DSRH/C

DSRH/C is compact probe for measurement of relative humidity and temperature. Relative humidity accuracy is  $\pm 3.5\%RH$  from 10%-90%RH at 25°C. Temperature measuring accuracy is  $\pm 0.5^{\circ}\text{C}$ . Operating temperature range is 0 to +50°C. Probe length is 100mm and diameter is 14mm. Probe is designed to be directly mounted to device without cable.

### **Power supply Adapter A1825**

Power supply adapter with CEE 7 plug, 100-240V 50-60Hz/5V DC, 1.2A for Web Sensor P8511 and Web Sensor P8541.

### **Device case holder for RACK 19" MP046**

MP046 is a universal holder for mounting of thermometer Web Sensor P8510 and Web Sensor P8511, P8541 to RACK 19".

### **Probes holder for RACK 19" MP047**

Universal holder for easy mounting probes in RACK 19".

### **Comet database**

Comet database provide a complex solution for data acquisition, alarm monitoring and measured data analyzing from Comet devices. Central database server is based on MS SQL technology. Client-server conception allows to easy and instant access to data. Data are accessible from multiple places by the Database Viewer software. One license of Comet Database includes also one license for Database Viewer.