

# LMI®

# DIAMONDBACK



## DIGITAL INDICATOR USER MANUAL

LMI Corporation  
Linear Measurement Instruments

101 N. Alloy Drive  
Fenton, MI 48430

810-714-5811  
[www.lmicorporation.com](http://www.lmicorporation.com)

## TABLE OF CONTENTS

SECTION	PAGE
1 INTRODUCTION.....	3
1.1 WARRANTY.....	3
1.2 CONTACT INFORMATION.....	3
1.3 AGENCY APPROVALS AND COMPLIANCE.....	3
1.4 PRECAUTIONS.....	4
1.5 PACKAGING CONTENTS.....	4
2 OVERVIEW .....	5
2.1 INDICATOR OVERVIEW AND DIMENSIONS.....	5-8
2.2 OPERATING KEYS OVERVIEW.....	6
2.3 LCD DESCRIPTIONS.....	6
3 BATTERIES .....	9
3.1 BATTERY ICON.....	9
3.2 CHANGING BATTERIES.....	9
4 CHANGING CONTACT TIPS.....	9
4.1 OPTIONAL CONTACT TIPS.....	10
5 INSTALLING LUG .....	10
6 MOUNTING THE DIGITAL INDICATOR .....	10
7 PROTECTIVE BOOT .....	11
7.1 REMOVING THE PROTECTIVE BOOT .....	11
7.2 RE-INSTALLING THE RUBBER CONNECTOR PLUGS.....	11
8 OPERATING PROCEDURES .....	12
8.1 ON/OFF.....	12
8.2 CHANGING +/- SIGN AND COUNTING DIRECTION.....	12
8.3 CHANGING UNITS.....	12
8.4 ZERO/ABS – MEASUREMENT MODES.....	13
8.5 SETTING THE PRESET VALUE.....	13
8.6 TOLERANCE JUDGEMENT MODE.....	14
8.7 SETTING/CHANGING THE TOLERANCE.....	15
8.8 SENDING DATA.....	16
8.9 LOCKING.....	16
9 CONNECTIONS/CABLE SPECIFICATIONS.....	16-19
9.1 WIRELESS OPTION.....	19
10 WIRELESS INDICATOR ADDENDUM.....	20

## SECTION 1: INTRODUCTION

First of all LMI would like to thank you for purchasing a Diamondback Series digital indicator. LMI values every customer and we look forward to working with you and serving your measurement needs. We appreciate your feedback and strive to provide the highest customer satisfaction with every tool we sell.

The LMI Diamondback Series digital indicator is a precise measurement tool that was designed to be used on the shop floor as well as the quality lab. To take full advantage of all the features packed into the Diamondback indicator please read the manual completely. If any problems or questions arise while reading the manual or operating the digital indicator, please feel free to contact LMI Corporation. Keep the manual for future reference and for warranty information.

### 1.1 WARRANTY

It is the goal of LMI Corporation to meet or exceed its customer's expectations toward our products. If the digital indicator displays defective workmanship or material, it will be covered under the warranty up to one year from date of original purchase. During the warranty period we will repair or, at our option, replace at no charge the product, if the product proves to be defective, provided it is returned, shipping prepaid to LMI. The warranty does not apply to the digital indicator if it has been accidentally damaged or misused or serviced or modified by anyone other than LMI Corporation. For any questions or concerns regarding the warranty contact LMI Corporation.

### 1.2 CONTACT INFORMATION

Hours of Operation: Monday through Friday 8am-5pm EST/DST

Phone: 810-714-5811

Fax: 810-714-5711

Website: [www.LMIcorporation.com](http://www.LMIcorporation.com)

EMAIL:

CUSTOMER SERVICES: [customerservice@LMIcorporation.com](mailto:customerservice@LMIcorporation.com)

SALES: [sales@LMIcorporation.com](mailto:sales@LMIcorporation.com)

TECHNICAL SUPPORT: [techsupport@LMIcorporation.com](mailto:techsupport@LMIcorporation.com)

### 1.3 AGENCY APPROVALS AND COMPLIANCE

European Union Directives: The product described in this documentation complies with the EU directives 73/23/EEC (Low Voltage Directive) and 89/336/EEC (EMC Directive) and bears the CE Mark accordingly. The product has been tested and complies with the requirements of EN 61326 (EN55011 1997 Class A) for Emissions and Immunity.

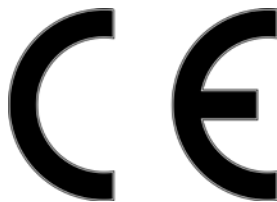

## 1.4 PRECAUTIONS

Read the following precautions to prevent the digital indicator from being damaged and to ensure proper functioning.

### IMPORTANT

- Do not drop or apply excessive force to the indicator
- Do not subject the indicator to blows or knocks
- Do not disassemble or modify the indicator; warranty will be forfeited
- Do not use sharp objects to press the keys; this could damage the keys and void your warranty
- Avoid excessively cold or hot climates
  - Allow sufficient time for the indicator to thermally stabilize if the indicator has moved between environments with different temperatures; Allow approximately 2 hours at room temperature to stabilize
  - Operating temperature: 10 ~ 40 degree C (50 ~ 104 degree F)
  - Storing temperature: -10 ~ 50 degree C (14 ~ 122 degree F)
- Protect data ports with rubber cap when not in use
- Avoid using around high voltage equipment
- Do not apply excessive force to spindle
- Use alcohol and soft cloth to clean spindle
- Do not put oil on spindle
- Dirt or debris will interfere with the movement of the spindle

### Safety and Precautions on LCD and Battery Disposal

- A Liquid Crystal Display (LCD) is used in this product; When disposing, follow the ordinances or regulations of the respective local government
- The Liquid Crystal Display contains irritating substances; Should the substance accidentally come into contact with the eye or skin, rinse with clean, running water; If the substance gets into the mouth, immediately rinse out the mouth, and contact a local physician; DO NOT SWALLOW THE SUBSTANCE.
- Batteries supplied are not rechargeable
- Keep batteries away from heat and fires, which may cause batteries to leak or explode
- Do not mix battery types
- ONLY USE AAA alkaline batteries
- Make sure polarities are correct when installing new batteries
- Remove batteries if indicator will not be used for long periods of time

## 1.5 PACKAGING CONTENTS

The package should be inspected immediately to verify that all of the parts are accounted for and no damage exists. If anything is missing or damaged, contact LMI Corporation immediately. The package should consist of the following:

- LMI Diamondback Digital Indicator
- CD-ROM consisting of a user manual and important USB drivers
- Certificate of Calibration
- (2) AAA Alkaline Batteries

## SECTION 2: OVERVIEW

### 2.1 INDICATOR OVERVIEW AND DIMENSIONS



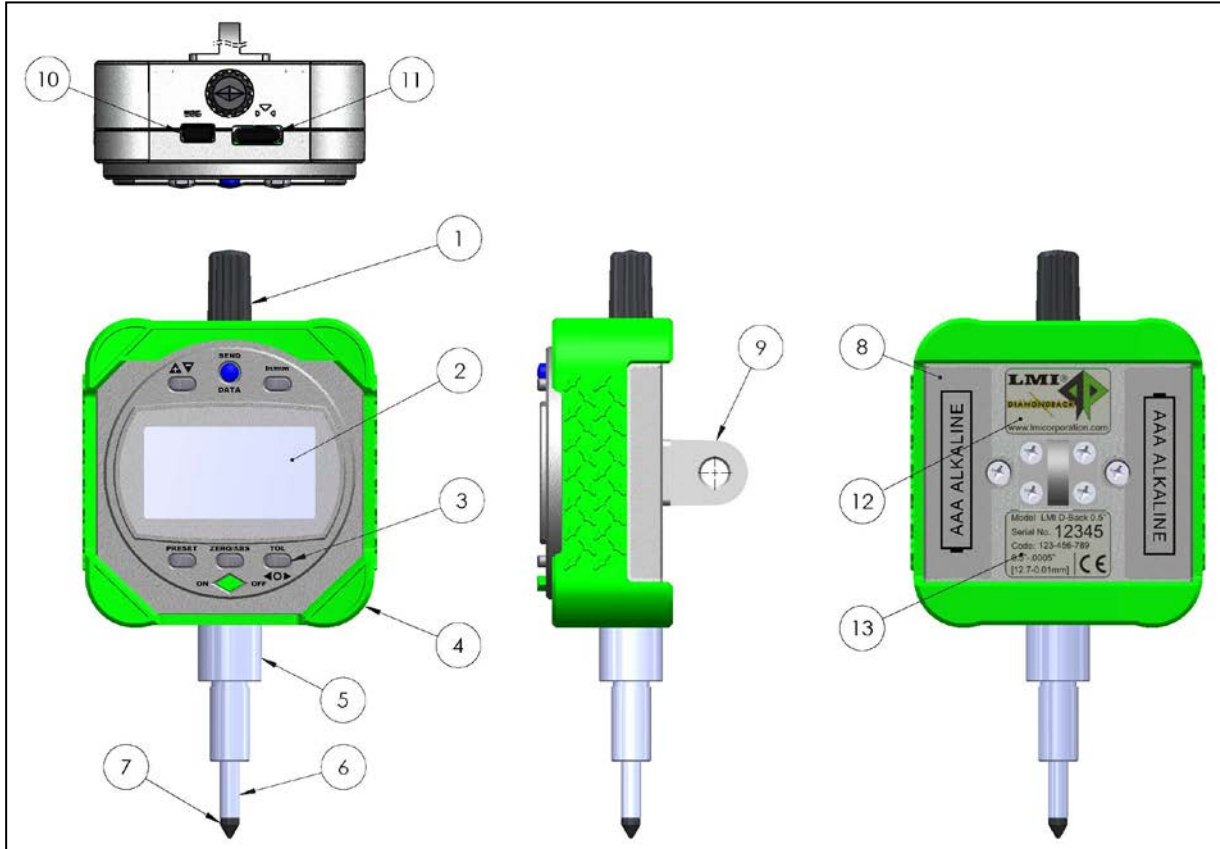

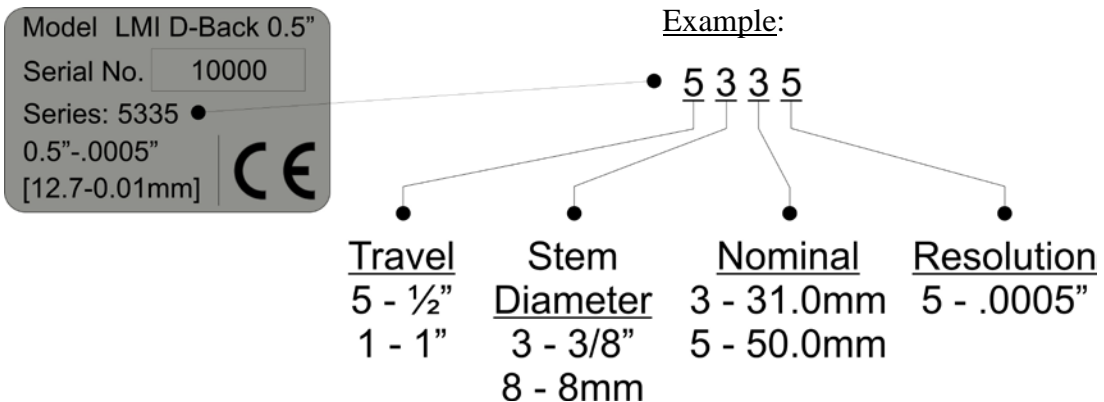

- |                    |                                    |
|--------------------|------------------------------------|
| 1. Top Cap         | 7. Contact Point                   |
| 2. LCD Screen      | 8. Battery Cover (2)               |
| 3. Function Keys   | 9. Mounting Lug (optional)         |
| 4. Protective Boot | 10. USB Port                       |
| 5. Stem            | 11. Serial Port and Digimatic Port |
| 6. Spindle         | 12. Product Label                  |
|                    | 13. Identification Label           |



Here is a break down of the identification label:







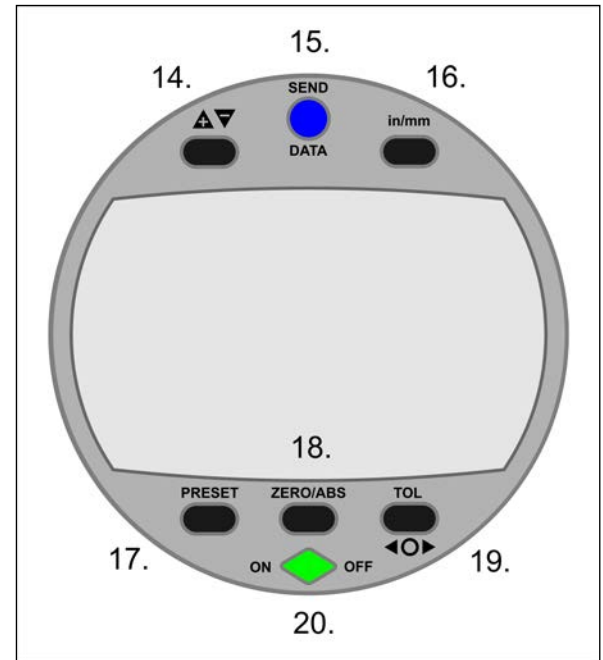

## 2.2 OPERATING KEYS OVERVIEW:

14. +/-: toggles between negative and positive values and changes the counting direction 
15. **SEND DATA**: sends data through the output ports Serial/Digimatic or USB 
16. **in/mm**: toggles between inches and millimeters 
17. **PRESET**: recalls and resets a reference value 
18. **ZERO/ABS**: toggles between ABSsolute and ZERO Mode 
19. **TOL**: toggles tolerance mode and resets tolerance limits 
20. **ON/OFF**: turns the indicator on and off and locks out button functionality 



## 2.3 LCD DESCRIPTION

21. **Directional arrows**, display which direction the indicator is measuring (  ) (i.e. value increases when contact point moves in direction of arrow)
22. **Battery icon**, displays power level of batteries (  )
23. **USB PWR** indicator, appears when a USB connector is plugged in and the indicator is powered by USB port ( **USB PWR** )
24. **Tolerance Symbols**, (only visible in TOL mode) displays greater than, less than or equal to the set tolerance limits (  )
25. **DATA**, appears when data is being sent ( **DATA** )
26. **LOCK**, appears when the indicator is in LOCK mode (  ) Only the On/Off and Send buttons are active
27. +/-, displays whether the value is positive or negative (  )
28. **Underscore**, appears when a digit is selected (  ) (Used to set TOL/PRESET Values)
29. **in**, displays when measuring in inches (displays four digits after the decimal; last digit can only display a 0 and 5) ( **in** )
30. **Numerical values location** (  )
31. **mm**, displays when measuring in millimeters (displays two digits after the decimal) ( **mm** )
32. **ABS**, appears when in ABSOLUTE mode ( **ABS** )
33. **PRESET**, appears when changing the preset value ( **PRESET** )
34. **SET**, appears when resetting a value ( **SET** ) (flashes for a portion of the TOL/PRESET setup operations)
35. **TOL**, appears when in TOLERANCE mode ( **TOL** )

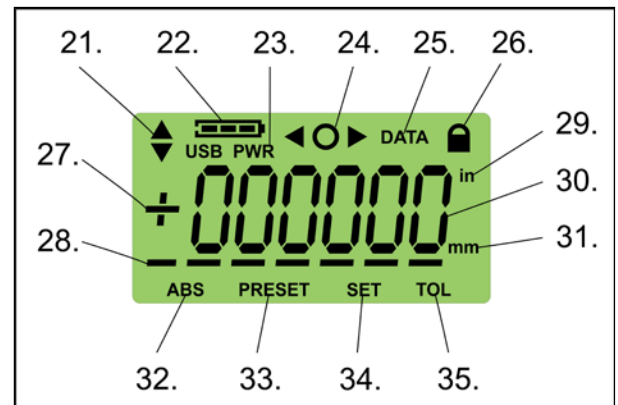

## 1/2" Travel Indicator Dimensions

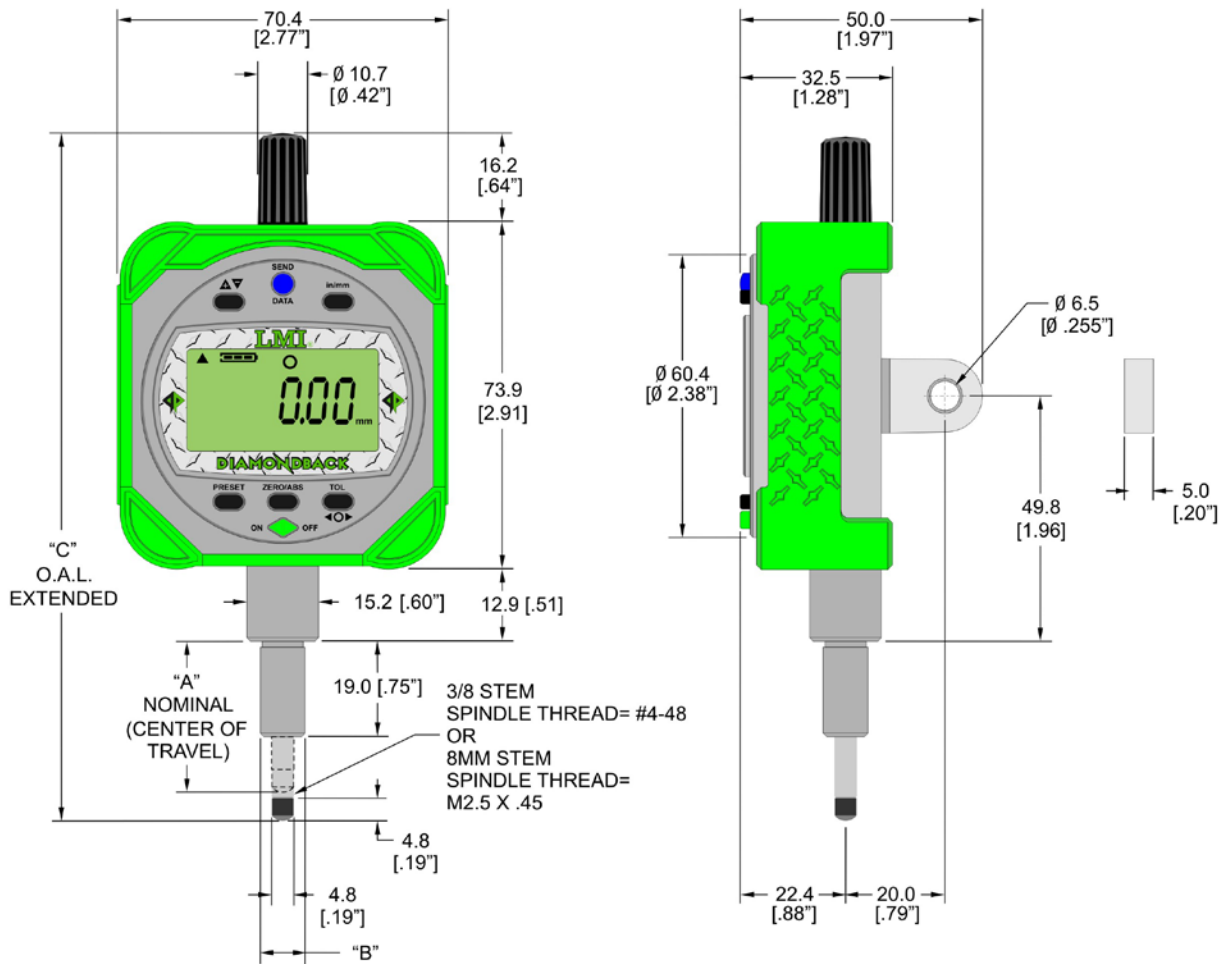

Model	Travel	Resolution	Accuracy	Measuring Force	A	B	C
LMI D-Back 5335	1/2" 12.7mm	.0005" .01mm	.0004" .01mm	1.0N or less	31.0	3/8"	5.77" 146.6mm
LMI D-Back 5355	1/2" 12.7mm	.0005" .01mm	.0004" .01mm	1.0N or less	50.0	3/8"	6.52" 165.6mm
LMI D-Back 5835	1/2" 12.7mm	.0005" .01mm	.0004" .01mm	1.0N or less	31.0	8.0mm	5.77" 146.6mm
LMI D-Back 5855	1/2" 12.7mm	.0005" .01mm	.0004" .01mm	1.0N or less	50.0	8.0mm	6.52" 165.6mm

## 1" Travel Indicator Dimensions

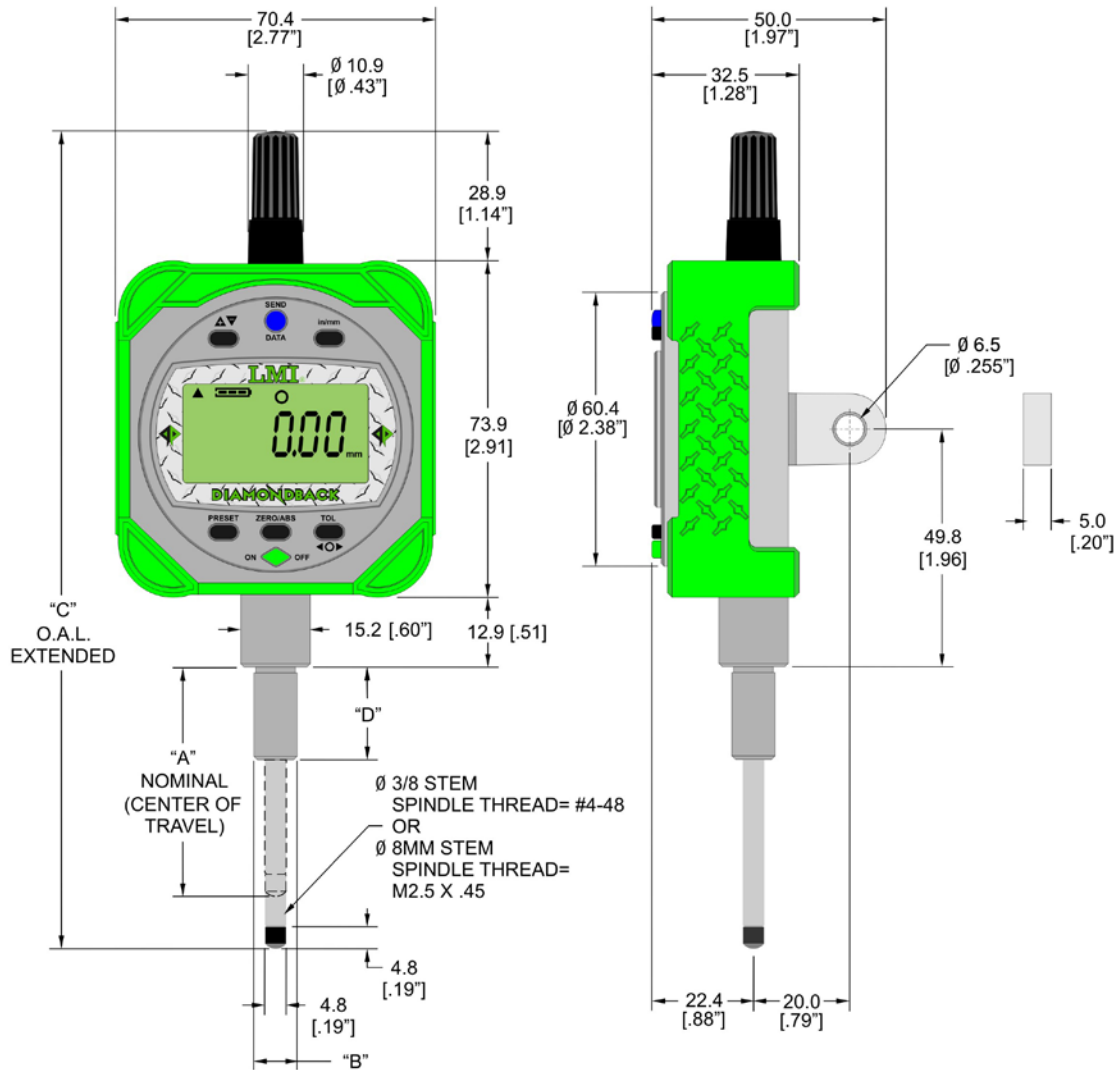

Model	Travel	Resolution	Accuracy	Measuring Force	A	B	C	D
LMI D-Back 1335	1.0" 25.4 mm	.0005" .01mm	.0008" .02mm	1.9N or less	31.0	3/8"	6.27" 159.3mm	.53" 13.3mm
LMI D-Back 1355	1.0" 25.4 mm	.0005" .01mm	.0008" .02mm	1.9N or less	50.0	3/8"	7.02" 178.3mm	.75" 19.0mm
LMI D-Back 1835	1.0" 25.4 mm	.0005" .01mm	.0008" .02mm	1.9N or less	31.0	8.0mm	6.27" 159.3mm	.53" 13.3mm
LMI D-Back 1855	1.0" 25.4 mm	.0005" .01mm	.0008" .02mm	1.9N or less	50.0	8.0mm	7.02" 178.3mm	.75" 19.0mm



## SECTION 3: BATTERIES

### 3.1 BATTERY ICON

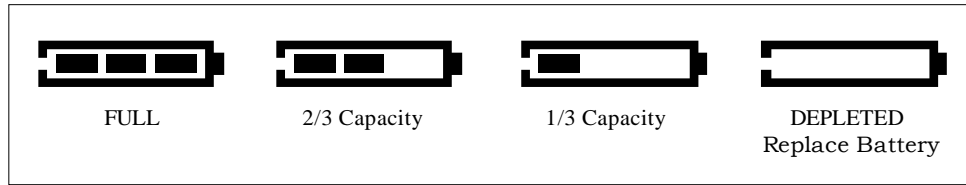

The battery icon indicates the condition of the batteries in the unit. The battery power level is divided into three segments (see illustration above). As the batteries are depleted the display will change as illustrated above. Depleted batteries must be replaced when all indicators have gone from the display. If the indicator is connected with a USB cable; a USB PWR icon will display below the battery icon. The unit is now powered via USB. Batteries are not required in this mode. Note: Data will be lost if USB cable is removed and the batteries are depleted or missing.

### 3.2 CHANGING BATTERIES

When putting in new batteries, the digital indicator will store the tolerance limits, preset values, and the mode the digital indicator was in before the batteries were replaced.

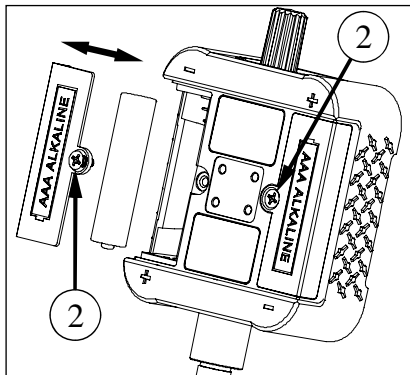

1. Verify that the unit is turned off.
2. Flip the digital indicator over so the LCD is facing down.
3. Using a philips screwdriver, turn screw counterclockwise to release cover.  
**NOTE: Screws will remain attached to cover.**
4. Remove battery cover.
5. Pull out the old batteries and replace them with new AAA alkaline batteries only.
6. Ensure that the polarities are correct, when installing the batteries. Polarity +/- is clearly marked on the unit.

## SECTION 4: CHANGING CONTACT TIPS

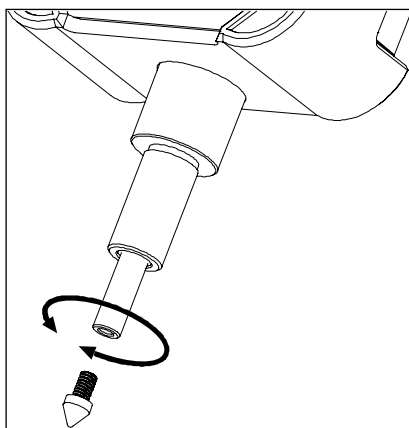



1. Hold the spindle with a pair of pliers and a clean piece of cloth and with another pair of pliers holding the tip; turn the tip counter clock wise to remove.
2. Place the tip on the spindle and turn the tip to the right to tighten. Then hold the spindle with a pair of pliers and a clean piece of cloth and with another pair of pliers holding the tip; tighten the tip to ensure that it is secure. Do not over tighten tip.

## 4.1 OPTIONAL CONTACT TIPS

LMI offers a variety of optional tips to fit the Diamondback Series indicators (LMI 037 Tip shipped standard on all Diamondback models). Each model is designed to be virtually indestructible by using our unique two piece construction. These durable tips come in #4-48UNF and M2.5x0.45 threads.

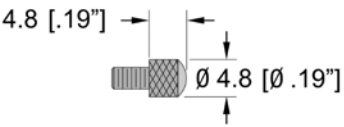
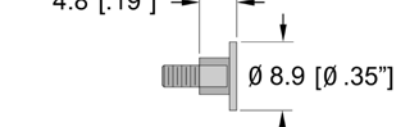
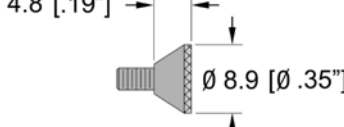
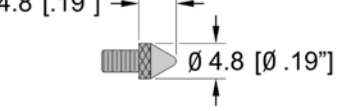
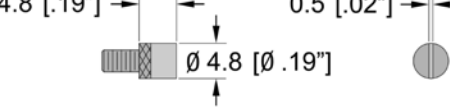
**Caution:** Other commercially available tips will fit the Diamondback Series indicator but they are not robust and should be avoided. If the indicator is dropped the tip may shear off leaving the threaded shank inside the spindle and will require the indicator to be sent in for repair.

 <p>LMI 037 4-48 UNF LMI 037M M2.5 x .45</p>	 <p>LMI 036 4-48 UNF LMI 036M M2.5 x .45</p>	 <p>LMI 038 4-48 UNF LMI 038M M2.5 x .45</p>
 <p>LMI 041 4-48 UNF LMI 041M M2.5 x .45</p>	 <p>LMI 052 4-48 UNF LMI 052M M2.5 x .45</p>	 <p>LMI 053 4-48 UNF LMI 053M M2.5 x .45 NON-MARRING</p>

## SECTION 5: INSTALLING THE LUG

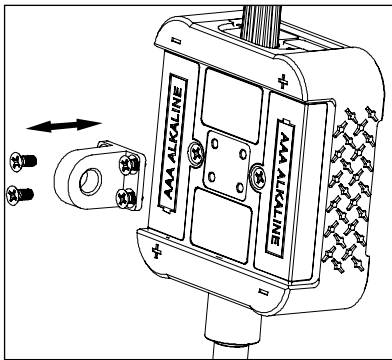

An optional mounting lug (Part no. LMI D-Back Lug) can be purchased for the indicator. To install the lug, turn the indicator so that the LCD is facing down. Align the lug on the recessed area centering the four screw holes. Install the screws in the holes. For pricing or to order the lug, please contact LMI Corporation.

## SECTION 6: MOUNTING THE DIGITAL INDICATOR

Secure the digital indicator by using the back lug or secure the stem using a split mounting block or collet. Do not over tighten the split mounting block; this could cause serious damage to the spindle. Do not apply excessive force to the stem; this will damage the stem and possibly the spindle.

**Attention:** Do not clamp the indicator using a screw directly onto the stem, this will damage the stem and possibly prevent smooth operation of the spindle.

## SECTION 7: PROTECTIVE BOOT

### 7.1 REMOVING THE PROTECTIVE BOOT

It may be necessary at some point to remove the protective rubber boot. Follow the steps below to properly remove the boot. To replace the boot simply reverse the steps.



Step #1 – Unscrew and remove the top cap



Step #2 – Peel back the two top corners of the boot and lift off towards the back of the indicator.

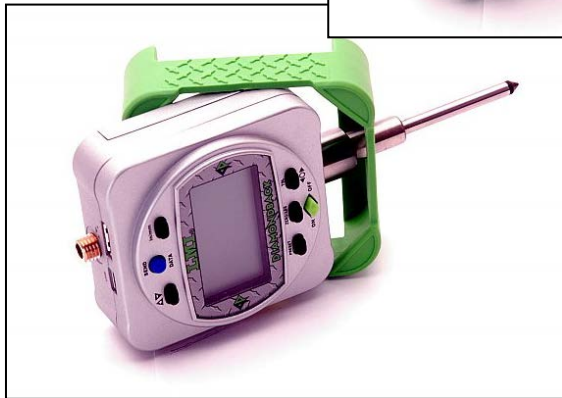

Step #3 – Continue removing the boot from the back while sliding the boot down the stem and off the spindle

### 7.2 RE-INSTALLING THE RUBBER CONNECTOR PLUGS

If a cable is not being used and plugged into the connector ports, the rubber plugs should be re-installed to keep the connectors clean. The rubber plugs were designed to be a tight fit to keep out dirt and grime to give you years of shop floor use. But there is a simple technique to re-install the plugs.

Step #1 – Pull the tab back and line up to the edge of the connector

Step #2 – Push down on top to insert plug, with a wiggle motion to seat the plug



## SECTION 8: OPERATING PROCEDURES

### 8.1 ON/OFF

To turn on the indicator, press and release the ON/OFF button. To turn off the indicator, press and release the ON/OFF button. The digital indicator will turn on in the same mode it was in before it was turned off and the selected values for tolerance and preset will be kept. Except when in a setup mode, such as the mode for setting the preset value, if the digital indicator is turned off, then the digital indicator will enter the mode it was in before it entered the preset value mode.

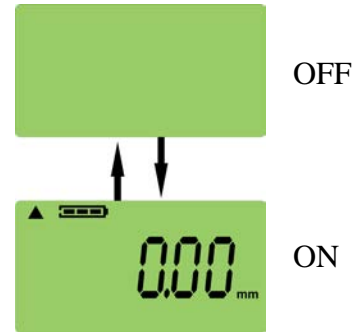

### 8.2 CHANGING +/- SIGN AND COUNTING DIRECTION

To change the positive and negative value, press and release the +/- button and the sign will change to the left of the value. This will also change the counting direction the indicator measures and the arrows indicate the direction of increasing values.

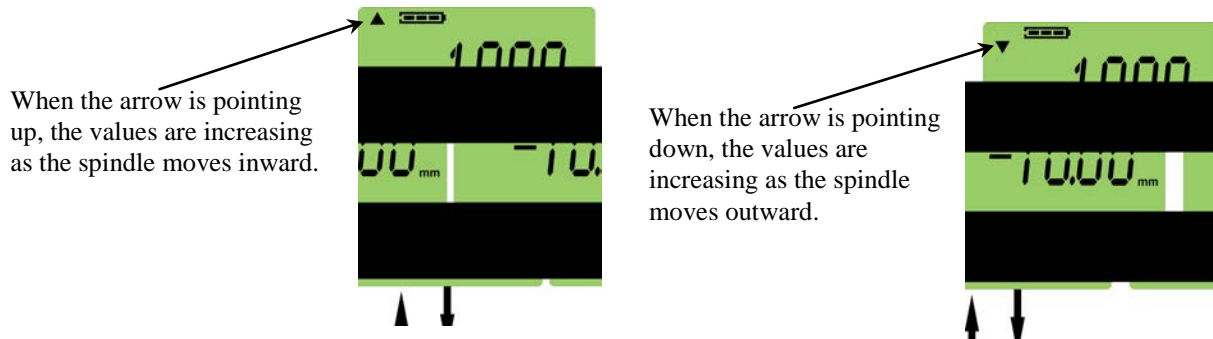

### 8.3 CHANGING UNITS (in/mm)

To the right of the numbers is the unit of measurement. To change the unit of measurement, press and release the in/mm button.

**NOTE:** mm/in have the maximum of six digits.

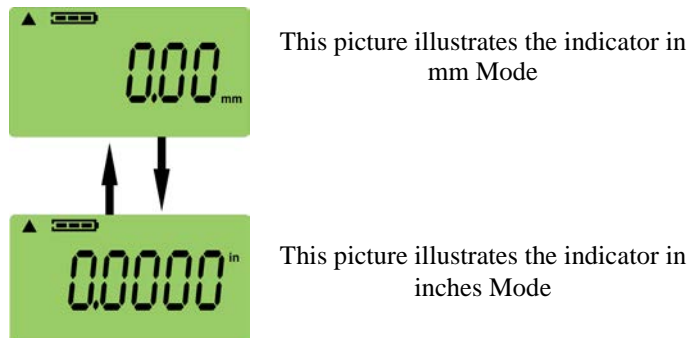

## 8.4 ZERO/ABS – MEASUREMENT MODES

The digital indicator has two modes to take measurements. ZERO Mode (also known as INCRemental Mode) is used to take measurements from a value of zero. ABS or Absolute Mode is used to take measurements from a Preset value.

To enter ZERO Mode, press and release the ZERO/ABS button. The LCD will display all zeros.

To enter ABS Mode, press and release the PRESET button. Press and release the PRESET button will take the current position of the spindle and assign it your Preset value. The ABS icon will appear in the bottom left corner of the LCD. The default Preset value is 10.0mm. To change the Preset see section 8.5. If you switch to ZERO Mode and want to return to your last Preset stem position in ABS Mode press and hold the ZERO/ABS button for 3 seconds.

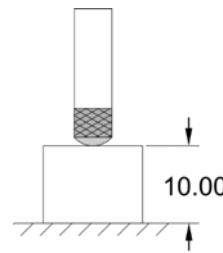

### ZERO Mode



### ABS Mode



**NOTE:** Tolerance Mode can be used with ZERO Mode and ABS Mode

## 8.5 SETTING THE PRESET VALUE

To change the PRESET value, press and hold the PRESET button for 3 seconds. The previous value will be displayed. Press and hold the PRESET button to select the digit you want to change. Press and release the PRESET button to change the value. When finished, press and hold the PRESET button until none of the digits are underscored and SET is flashing. Press and release the PRESET button and the value will be set. Note that if you set the PRESET value to the max (9999.99 mm or 99.9995 in) and the measurement exceeds those values, then the LCD will display “Err-OL”, meaning a character overload.

### EXAMPLE:

For this example, we are going to change the default PRESET value of +10.00 to the new value of +5.00mm.



Press and hold PRESET for 3 seconds. The previous value will display. SET will flash



Press and hold PRESET until the underscore is under the one.



Press and release PRESET until the digit becomes a zero.



Press and hold PRESET until the underscore is under the fourth digit.



Press and release PRESET until the fourth digit becomes a five.



Press and hold PRESET until the underscore is gone and SET starts to flash.



Press and release PRESET. The new value is now 5.00mm.

## 8.6 TOLERANCE JUDGMENT MODE

Tolerance Judgment Mode will display whether the measured value is within the tolerance limits that have been set by the user. The TOL icon will display in the bottom right hand corner of the LCD when in Tolerance Judgment Mode. There are two different ways of viewing the Tolerance Judgment Mode, with and without numerical values. Press and release the TOL button to change the view or turn Tolerance Judgment Mode off. See 8.7 to set the tolerance limits.

### DISPLAYING TOLERANCE JUDGEMENT WITH NUMERICAL VALUES

To display the tolerance judgment with numerical values, press and release the TOL button. The tolerance symbols will appear in the upper middle section of the LCD.

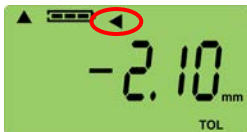

Measured value  
is less than the  
Lower Limit



Measured value is with  
in tolerance



Measured value is  
greater than the  
Upper Limit

### DISPLAYING TOLERANCE JUDGEMENT WITHOUT NUMERICAL VALUES

In order to display the tolerance judgment without numerical values make sure the digital indicator is in TOL mode and is displaying the tolerance with numerical values, then press and release the TOL button and the tolerance brackets will appear.



Measured value  
is less than the  
Lower Limit



Measured value is with  
in tolerance



Measured value is  
greater than the  
Upper Limit

## 8.7 SETTING/CHANGING TOLERANCES LIMITS

To enter the mode that changes the tolerance value, Press and hold the TOL button for 3 seconds. The previously set value will display. The default values are +2.00mm and -2.00 mm. Press and hold the TOL button until the underscore is below the digit you would like to change. Press and release the TOL button to change the value of the digit to the desired value. When you are finished, press and hold the TOL button until none of the digits are underscored and SET is flashing. Press and release the TOL button and the new values will be set. Be aware that there are two values, the first value to be displayed is the Upper Limit and the second value to be displayed is the Lower Limit.

**NOTE:** the Lower Limit cannot be greater than or equal to the Upper Limit. (an error will be displayed if attempted)

### EXAMPLE:

For this example, we are going to change from the default values of +2.00mm and -2.00mm so that the Upper Limit is +3.50mm and the Lower Limit is -3.50mm.

**Note:** Arrow pointing to the right indicates setting the Upper Limit



Press and hold TOL for 3 seconds. The previous Upper Limit will be displayed and SET will flash.



Press and hold TOL until the underscore is under the fourth



Press and release TOL until the fourth digit reads three.



Press and hold TOL until the underscore appears under the fifth digit.



Press and release TOL until the fifth digit reads five.

**Note:** Arrow pointing to the left indicates setting the Lower Limit



1. Press and hold TOL until the underscore is gone. SET will flash.  
2. Press and release TOL and the Lower Limit and arrow icon will display



Press and hold TOL until the underscore is under the fourth digit.



Press and release TOL until the fourth digit reads three.



Press and hold TOL until the underscore is under the fifth digit.



Press and release TOL until the fifth digit reads five.



Press and hold TOL until the underscore is gone. SET will flash.



Press and release TOL and the new Upper and Lower Limits are set

## 8.8 SENDING DATA

The digital indicator can send data by USB, Digimatic, or RS232. The ports to connect the cables are located on top of the indicator. Please see SECTION 9 for specific details on connections.



1. Remove the rubber cap off the connector that is to be used.
2. Plug in the corresponding plug to the connector.
3. Turn on the digital indicator.
4. When ready to send data, press the Send button on the digital indicator.

**NOTE:** When the digital indicator is sending data the DATA symbol will appear until the data is completely sent. The DATA icon will only display when a cable is plugged into the indicator.

## 8.9 LOCKING

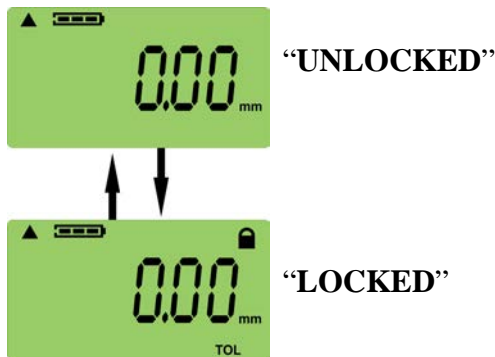

The Lock Mode is very useful to limit the functions once the indicator is properly set up and to avoid any unintentional changes. In the Lock Mode the digital indicator can be turned on/off and send data, but all the other functions will be locked out. To Lock your indicator make sure the unit is power on. Press and hold the ON/OFF button and the Lock icon  will appear in the upper right hand corner. To Unlock, press and hold the ON/OFF button and all the functions will return to each

## 8.10 SCREEN FLIP

The digital indicator LCD screen can be Flipped so that the screen can be read regardless of how the indicator is entered into a part. To Flip/Invert the LCD hold the +/- button down for 3-5 seconds until the screen has Flipped. To Flip the screen back again hold the +/- button for 3-5 seconds.

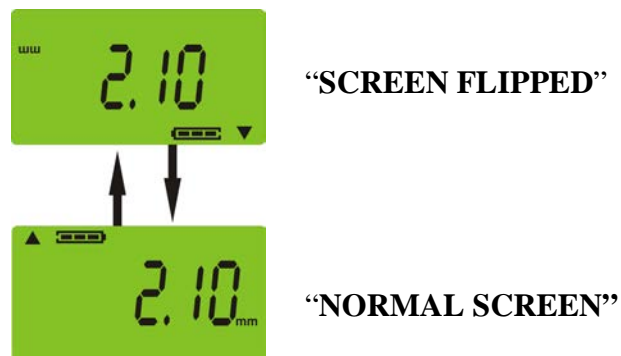

When the screen is flipped, only the reading will flip. No other icons will flip on the LCD screen.<sup>1</sup>

<sup>1</sup> In the normal Screen mode when set to inches the resolution of display on the LCD is 4 decimal places, in the Flip mode the resolution of display is only 3 decimal places.



## SECTION 9: CONNECTIONS/CABLE SPECIFICATIONS

LMI offers a variety of software and hardware solutions to collect data or even multiplex the Diamondback Series indicators. Contact LMI to provide you with the most efficient solution.

There are three methods that can be used for transferring data from the unit to a base unit, such as a PC. The methods for transferring data are USB using the LMI 6026 cable, Digimatic using the LMI 6028 cable and RS232 using the LMI 6027 cable.

Note that the cables are not included, but may be purchased from LMI Corporation. In order to communicate using a USB cable the PC requires a driver to be installed. The drivers may be installed from the CD-ROM that was included or on the LMI's web site [www.lmicorporation.com](http://www.lmicorporation.com).

### CONNECTIONS

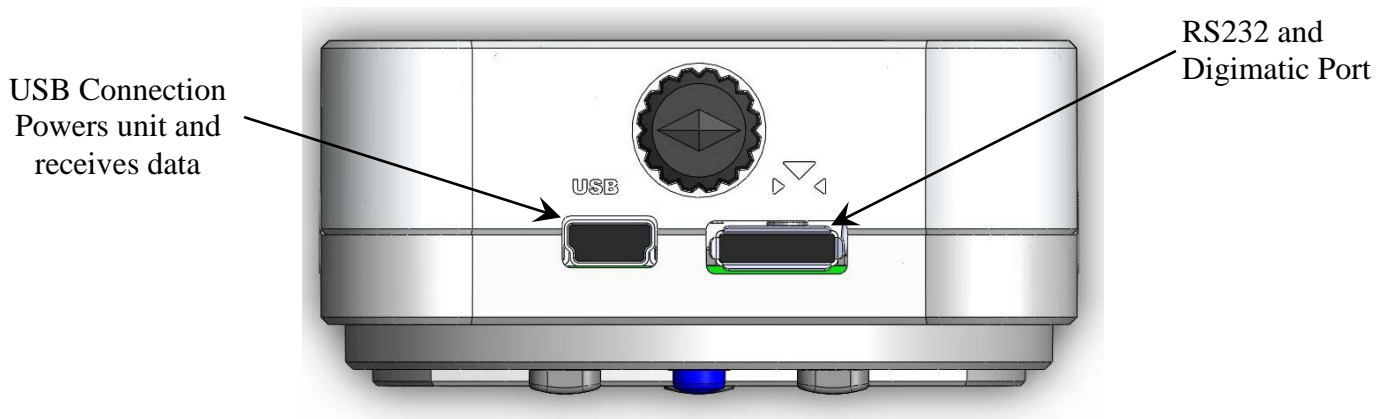

### USB

USB is a virtual COM-Interface. Drivers will be required for the digital indicator to communicate to the PC. To install the drivers, insert the CD-ROM that came with the digital indicator. Click on the Install Drivers tab and click on Install Drivers again. Once the drivers are loaded, the digital indicator will be able to communicate via USB. The drivers will emulate a virtual COM-Port for every indicator that is connected to the PC. The application software communicates to the instrument in exactly the same manner as a normal hardware COM-port.

The default baud rate for using a USB connection through a virtual com port is 57600 bits per second. You can change the baud rate to 9600 bits per second by pressing and holding the SEND button for 5 seconds. The LCD screen will highlight all the characters indicating that the baud rate has been changed. The baud rate will remain changed even after the unit is powered off. Press and hold the SEND button again until the LCD highlights to change the baud rate back to 57600.

Data format: [Reading] followed by Carriage Return i.e. 5.00 {CR}

COM Settings: Baud Rate 57600, parity: none, stop bit: 1, and data bits: 8  
Press and Hold (5 seconds) the SEND button to switch the baud rate to 9600 bps

LMI 6026 Cable  
USB A to MINI USB B

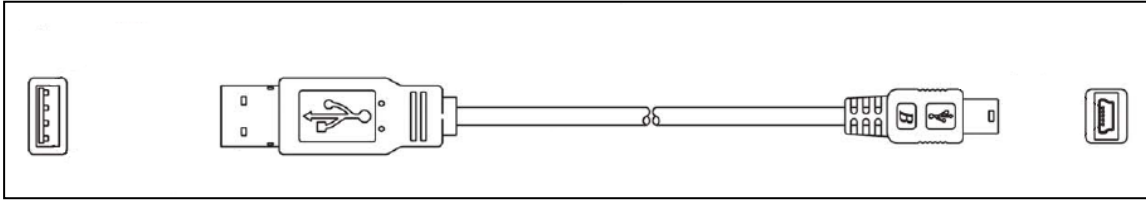

## RS232

The RS232 port is used to connect the digital indicator directly to a PC COM port. For this type of connection, an LMI 6027 cable will be required. The cable will plug into the top right hand port. Align the triangles icons marked on the connector and the indicator. Then plug the D Sub 9 Pin connector into a standard PC COM port.

The default baud rate for communicating to a com port is 57600 bits per second. You can change the baud rate to 9600 bits per second by pressing and holding the SEND button for 5 seconds. The LCD screen will highlight all the characters indicating that the baud rate has been changed. The baud rate will remain changed even after the unit is powered off. Press and hold the SEND button again until the LCD highlights to change the baud rate back to 57600.

Data format: [Reading] followed by Carriage Return i.e. 5.00 {CR}

COM Settings: Baud Rate 57600, parity: none, stop bit: 1, and data bits: 8  
 Press and Hold (5 seconds) the SEND button to switch the baud rate to 9600 bps

LMI 6027  
 DB9 to 10 Pin Indicator Plug

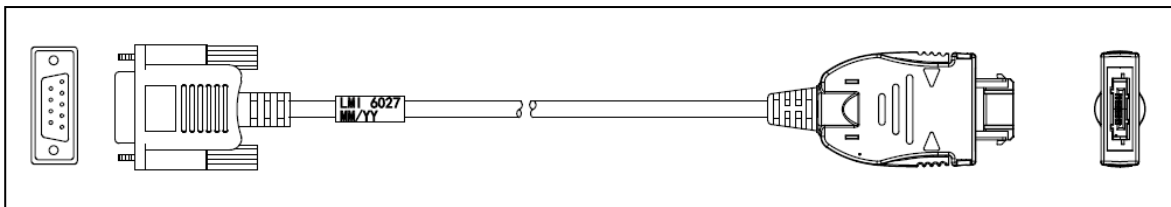

## Digimatic

The Digimatic port is used to connect the digital indicator to a Mitutoyo compatible device. For connecting via Digimatic, an LMI 6028 cable will be required. The cable will plug into the top right hand port. Align the triangles icons marked on the connector and the indicator. Then plug the 10 pin (2 x 5) box header into the Digimatic device. The data conforms to the Mitutoyo Digimatic protocol.

LMI 6028  
 10 Pin (2 x 5) Box Header to 10 Pin Indicator Plug

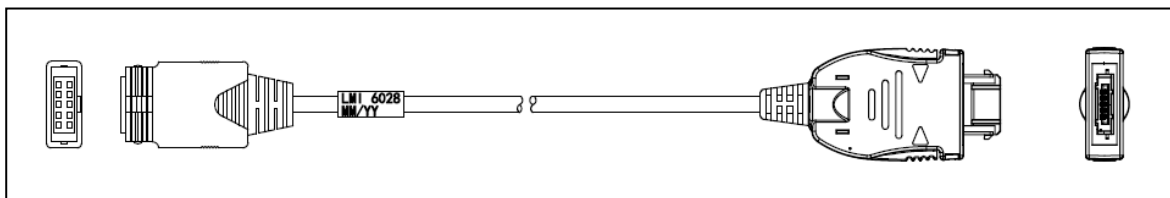

## 9.1 WIRELESS OPTION

An add-on wireless module is available from LMI to send data wirelessly to a PC. The wireless module plugs directly into the serial port on the indicator and attaches to the back of the indicator. The module is battery operated and will last for over 250,000 samples. Contact LMI on how to eliminate the cable and go wireless.

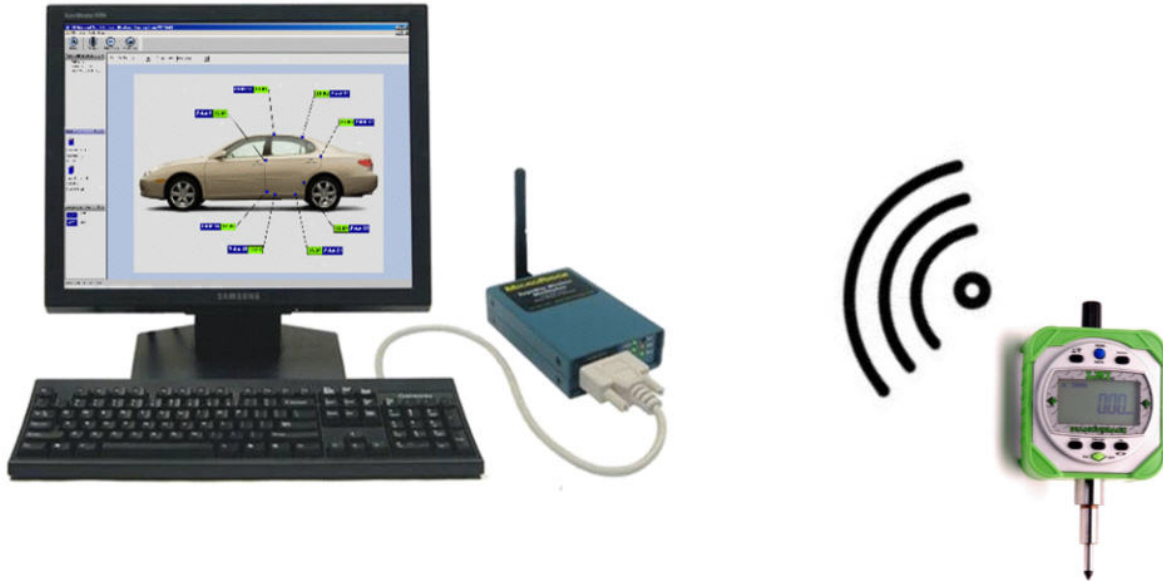

## 9.2 SERIAL COMMANDS

The Digital Indicator can receive serial command from a remote PC following the protocol outlined below. All commands must have [ ] around the command string. All commands are case sensitive.

[REQ] The REQ command will request a reading from the Digital Indicator at its current position. The response string will be the current readings followed by a Carriage Return.

Example Sent: **[REQ]**

Example Response: **[REQ] 5. 53{CR}**

[ZERO] The ZERO command will ZERO the Indicator at its current position.

Example Sent: **[ZERO]**

Example Response: **[ZERO]**

[STRM] The STRM command will set the indicator to stream live data to the local COM Port.

Example Sent: **[STRM]**

Example Response: **[STRM] 8. 04{CR}**

**8. 04{CR}**

**8. 04{CR}**

**8. 04{CR}**

**8. 04{CR}**

**8. 04{CR}**

**8. 04{CR}**

To shut off the STRM command send the [STRM] command again.

## **10.0 WIRELESS INDICATOR ADDENDUM**

The LMI Wireless Digital Indicator can send readings to a PC via a Microridge Mobile Collect USB Base unit. When the blue “SEND DATA” button is pressed the reading is transmitted to the base. The LCD “DATA” icon appears in the upper right hand corner of the LCD during transmission. If the base unit did not receive the reading correctly the message “rF Err” will appear on the LCD.

This LMI wireless gauge is associated to a base unit using the LMI Wireless Utility. By holding in the in/mm button for 3 seconds the unit will display “SEt UP” on the LCD and enter the setup mode. This mode is indicated by the flashing LEFT/RIGHT arrows on the LCD. Hold the in/mm button down for 3 seconds to exit the setup mode. After 5 minutes of inactivity the unit will exit the setup mode automatically. See the section on associating your gauge using the LMI Wireless Utility.

The range of wireless transmission is greatly affected by the environment in which the unit is used. Average distance for good transmissions is approximately 100 feet.

The AAA Alkaline batteries that come with the unit are good for approximately 500,000 data transmissions.