



HARBIN ROPV INDUSTRY DEVELOPMENT CENTER

ROPV R80 S Series User Manual

For Use with the Following ROPV Pressure Vessel Models:

R80 150S R80 250S R80 300S R80 400S R80 450S

Headquarters

Harbin ROPV Industry Development Center

100 Hongqi St.

Xiangfang District

Harbin, China 150036

Tel: +86-451-5515-5144

Fax: +86-451-5515-5124

Email: ropv@ropv.com.cn

Website: www.ropv.com.cn

General Product Description – R80 S Series Side Port Membrane Housing

R80 150S Design Pressure:	150PSI / 1.0Mpa / 10Bar (at 120°F / 49°C)
R80 250S Design Pressure:	250PSI / 1.7Mpa / 17Bar (at 120°F / 49°C)
R80 300S Design Pressure:	300PSI / 2.1Mpa / 21Bar (at 120°F / 49°C)
R80 400S Design Pressure:	400PSI / 2.8Mpa / 28Bar (at 120°F / 49°C)
R80 450S Design Pressure:	450PSI / 3.1Mpa / 31Bar (at 120°F / 49°C)
Min. Operating Temp.:	20°F / -6°C
Max. Operating Temp.:	120°F / 49°C
Factory Test Pressure:	ASME: 1.1x Design Pressure Standard: 1.5x Design Pressure
Burst Pressure:	6X Design Pressure
Operating pH Range:	3 – 11
Cleaning pH Range:	2 – 12 (less than 30 minutes)

General Warning – High Pressure Membrane Housing

ROPV Pressure Vessels are designed to provide safe operation over a long service life if properly installed, operated, and maintained. The vessel may cause loss of life, severe bodily harm, or property damage if not correctly installed, operated, or maintained. Read and understand all guidelines provided in the vessel User Manual. Observe every precaution contained therein. Failure to do so may result in malfunction and potential catastrophic failure. It is recommended that only qualified technicians experienced in servicing hydraulic systems work with this vessel. Misuse, incorrect assembly, or use of damaged/corroded components may result in catastrophic failure.

Vessel Use and Precautions

- Positive pressure up to the design pressure (PSI) of the specific model being used.
- Accommodates standard 8" nominal diameter spiral-wound element.
- The required vessel/element interface hardware is supplied with the vessel. Ensure that an element adapter is installed at each end of the vessel before use.
- Vessel expands under pressure and careful consideration must be taken when installing straps/saddles and system connection piping.
- Installation with the straps/saddles provided is strongly recommended
- Vessel should not support any other system components. Connections should be non-load bearing.
- Periodic inspection of the vessel end closure is recommended to ensure all parts are dry and free of corrosion.
- Failure to understand and follow all precautions may void warranty and result in catastrophic failure of the vessel.

- These guidelines are subject to change. Please check with ROPV to ensure that the User Manual is the latest version for the vessel model being used.
- Mount vessel using strap/saddle hardware provided and span recommended in the engineering drawing.
- Do not over tighten the straps – vessel must be allowed to expand under operation.
- Maximize the connection flexibility to allow for vessel growth under pressure.
- Align the side ports with the system manifold, correcting any misalignment before final installation.
- Provide overpressure protection in the system safety devices.
- Inspect end closures regularly for signs of corrosion. Immediate corrective action and/or replacement is suggested in case of corrosion.
- Relieve system pressure before working on the vessel.
- Do not attempt to over-tighten the Permeate Port connections as this may damage the end closure. One turn past hand tight should be sufficient.
- Ensure that the Trust Cone is installed on the downstream end of the vessel.
- Never operate the vessel in excess of its ratings. This may void the warranty and cause bodily or property damage.
- Do not operate the vessel permeate port over 125PSI.
- Flush the vessel with permeate before system shutdown to reduce the chance of corrosion.
- Do not install the vessel in direct sunlight.
- Operate the vessel within the recommended pH range - Operating pH Range: 3 – 11, Cleaning pH Range: 2 – 12 (less than 30 minutes).

Head Removal

Step 1 Shut Down System and Relieve System Pressure – The system must be shut down and all pressure relieved before conducting any maintenance or repair on the vessel.

Step 2 Disconnect Permeate Piping – The system permeate piping must be carefully removed from the permeate port of the vessel.

Step 3 Inspect End Closure – The end closure should be inspected for any signs of corrosion or damage. Surface corrosion can be removed with a wire brush, while flushing with water. Damaged components should be replaced with approved components from ROPV.

Step 4 Disconnect Locking Screws – Each of the three locking segments is held in place with a single locking screw. The locking screws can be unthreaded using an M6 / 7/32" hex wrench. The locking screws should be unthreaded from the head only, not from the locking segment. The locking screw and locking segment can be removed together.



Step 5 Remove the Locking Segment/Screw Assemblies – The locking segment/screw assemblies should be easily removed from the retaining groove. Should the assemblies be difficult to remove, it may be necessary to rock the head slightly or tap the head inward with a rubber mallet. Be careful when using metal tools, avoiding leveraging against the sidewall of the vessel or scratching the inside surface of the bell area.

Step 6 Remove the Head Assembly with One of the Following Techniques

ROPV Head Removal Tools – A set of head removal tools is available from ROPV. While not necessary for head removal, they have proven an effective and easy way to remove the vessel head without causing any damage to the vessel.

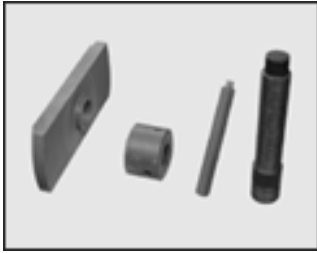

Picture 1

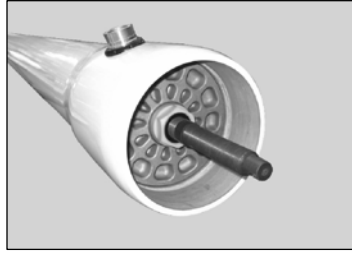

Picture 2

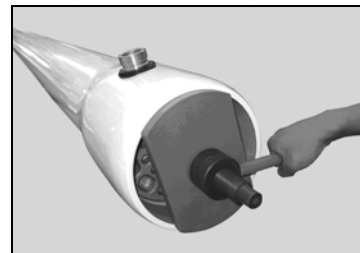

Picture 3

Picture 1 – Detail picture of head removal tools.

Picture 2 – Thread the center piece into the permeate port of the head assembly, to hand tight. Do not over tighten the center piece.

Picture 3 – Position nut, bearing rod, and bearing block as shown. Turn bearing rod clockwise. The head will move with the bearing rod as it moves toward the end of the vessel. You will be able to remove the head once it has cleared the retaining groove area of the vessel.

Alternative Head Removal – It is possible to remove the head assembly without the ROPV head removal tools. A 1" NPT Male threaded piece of PVC (or similar material) pipe should be threaded into the head permeate port to hand tightness. Pull the pipe outward to remove the head. If the vessel has been in operation for an extended time, a slight rocking motion or forceful tug may be required to break the head seal bond. Also, a handle at the end of the pipe will ease head removal – forming a T with the pipe that threads into the permeate port.

Complete Head Assembly with Adapter

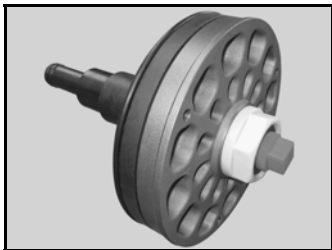

Head Disassembly and Inspection

Step 1 Remove the Head O-ring – Use a non-metallic, rounded tool to start the o-ring out of the o-ring groove. Once a small portion of the o-ring has been lifted out of the groove, use your hand to work the remainder of the o-ring out of the groove. Damaged or cut o-rings must be replaced during re-installation of the head.

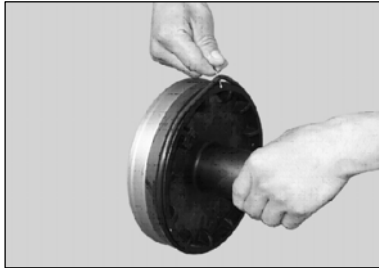

Step 2 Remove Adapter – Grasp the adapter and slowly pull from the bearing plate/permeate port. A slight rotating motion may ease the removal of the adapter. There is a set of double o-rings on the inside diameter of the permeate port that must be inspected for damage once the adapter is removed. Damaged o-rings must be replaced before re-installation.



Step 3 Remove Bearing Plate – Use a wrench to remove the permeate port Locknut. The locknut is reverse threaded (or left hand threaded) and must be turned clockwise to be removed and counter clockwise to be installed. After removing the locknut, the bearing plate and sealing plate can be separated.



Special Note for R400 S / 450 S Users – The head for the R80 400S/450S uses a different head configuration than the other R80 S Series. There is a separate permeate port (not integrated into sealing plate) and flat bearing plate. Once the locknut is removed from the permeate port, you must first remove the bearing plate and then the sealing plate. The sealing plate is not an integral part of the permeate port as with other models shown in the guide.

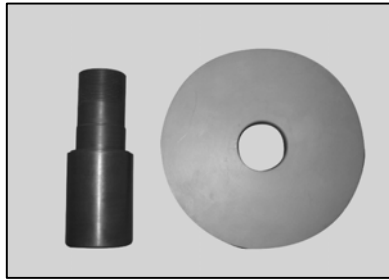

**Sealing Plate and
Permeate Port**

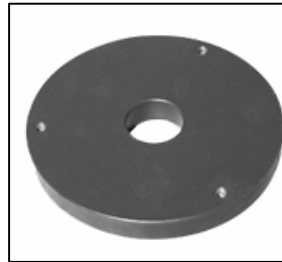

Bearing Plate

Step 4 Clean All Components – All components should be cleaned with a mild soap solution or clean water. The components should be air dried or dried with a lint-free towel.

Step 5 Inspect All Components – All components should be carefully inspected for signs of corrosion and damage. Components exhibiting such should be replaced before re-installation. All o-rings should be carefully inspected for signs of damage. It is recommended that all o-rings be replaced during each complete servicing of the vessel. Failure to do so may cause poor system performance.

Step 6 Inspect Inside Vessel Surface – The inside surface of the vessel should also be inspected once the membrane elements have been removed. Special attention should be paid to identify any scratches, damage or foreign matter. Surface scratches can be repaired by carefully sanding the effected surface with 600-grit sandpaper. A combination of soapy water and fresh water should be used to flush the area during sanding. Clean water should be used to clean the area after sanding. Any extemporaneous matter can be removed with a soft cloth, soapy water, and a clean water flush. Damaged vessels should not be used under any circumstances.

Picture of Disassembled Head Components



Head Reassembly

Step 1 Inspect All Head Components – All head components should be free from scratches, foreign matter, or any sign of damage. Please see Step 6 above for additional information about cleaning head components. Scratched or damaged components should be replaced with ROPV supplied replacement components. All o-rings should be carefully inspected for signs of damage. It is recommended that all o-rings be replaced during each complete servicing of the vessel. Failure to do so may cause poor system performance.

Step 2 Install Permeate Port O-rings - All o-rings should be coated with a thin layer of glycerine before installation. Care should be used to minimize the amount of glycerine applied and any excess should be removed. Petroleum based lubricants should not be used as they may cause membrane damage. Seat one o-ring into each of the two grooves located on the inside diameter of the permeate port.

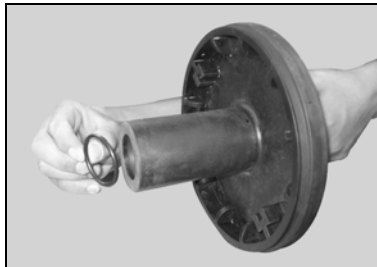

Step 3 Place Bearing Over Permeate Port/Sealing Plate

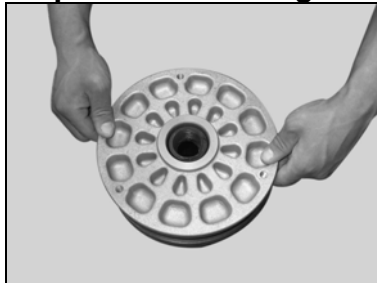

Step 4 Thread Lock Nut Onto Permeate Port – Lock nut should be tightened to hand-tightness using a wrench for a final half-turn. Do not over tighten the Lock Nut – maximum torque guideline: 15Nm. Note that the threads of the Permeate Port are reverse or left-hand threaded.

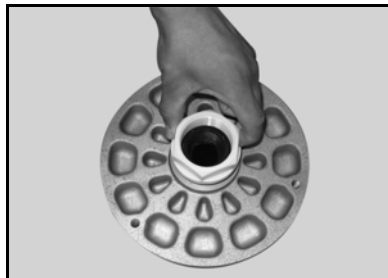

Step 5 Install Permeate Port and Adapter O-rings – All o-rings should be coated with a thin layer of glycerine before installation. Seat one permeate port o-ring into each of the two grooves located at the element end, outside diameter of the adapter.

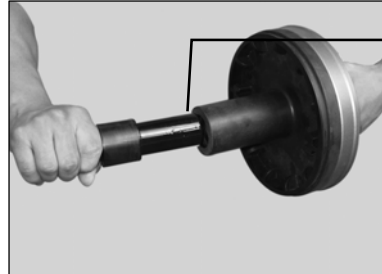

**Location of
Permeate
Port Seals**

Step 6 Install Adapter – The adapter should be pushed into the permeate port until the wider diameter middle section is flush against the end of the permeate port. Simultaneously pushing and turning the adapter will ease installation.

Step 7 Install Head O-ring – All o-rings should be coated with a thin layer of glycerine before installation. Seat the head o-ring into the groove on the outside diameter of the head.

Complete Head Assembly with Adapter

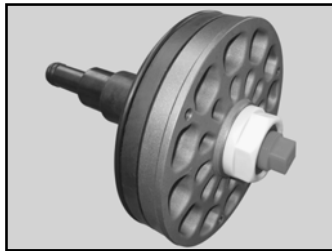

Head Installation

Step 1 Follow All Steps Outlined in the Head Reassembly Section

Step 2 Install Head – Hold the head assembly with both hands, square to the axis of the vessel. Push firmly with both hands until the head is correctly positioned and the retaining groove is visible. It may be necessary to use a rubber mallet to tap the head into its engaged position. The thrust cone must be installed with the head at the downstream end of the vessel.

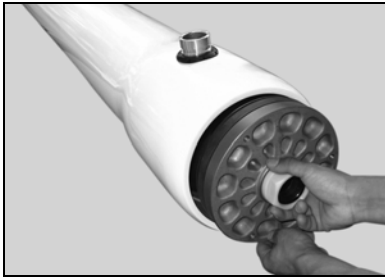

Step 3 Install Locking Kit Segments – Clean and dry the retaining groove. Position the first locking segment so that the end section sits in the retaining groove and the screw aligns with one of the threaded openings in the bearing plate. Use an M6 / 7/32" hex wrench to tighten the screw until snug. Do not over-tighten – maximum torque guideline: 10Nm. Install the two other segments in the same manner. Conduct a final tightness check of each screw after all three segments are installed.

Step 4 Reconnect Permeate Piping – Reconnect the system permeate piping to the permeate port.

Step 5 Conduct Pre-Pressurization Inspection – A thorough pre-pressurization inspection should be conducted, including verifying that the heads are properly installed, system piping connections are in place, elements are installed, adapters are installed, and thrust cone is installed at downstream end of the vessel.

Step 6 Pressurize System

Step 7 Inspect for Leaks – All connections should be free from leaks. Do not operate leaking vessels.

Piping and Mounting Recommendations

Use two flexible Victaulic™ connections with an intermediate section of pipe when possible. This is the preferred method for connecting the feed/concentrate ports to the system piping, especially when system manifold tolerances can not be guaranteed. There is a maximum 0.03" misalignment allowance per port.

Single flexible Victaulic™ connections should only be used when the axial misalignment from the port to the manifold is less than 0.03" per port. Make sure the vessel is centered on the rack when checking for port/manifold alignment.

Using intermediate flexible Victaulic™ connections in the manifold will ease port alignment and vessel installation.

Do not force any connections.

The Header and related piping should be self-supported.

Space strap/saddle locations using "S" dimension shown in model engineering drawing. -4 and longer vessels have a third strap/saddle assembly, to be installed at the center point of the vessel.

Tighten straps to hand tightness plus one turn.

Manifold span should be greater than vessel span to allow for vessel growth under pressure.

R80 S Series Parts List

Part Name	R80150S	R80250S	R80300S	R80400S	R80450S
Shell	8001.1-7	8002.1-7	8003.1-7	8004.1-7	8004.8-14
Bearing Plate	8010.2			8008.2	
Sealing Plate	8011			80510.2	
Plug	8013				
Permeate Port				8064.2	
Permeate Port Locknut	8014.1				
Feed/Conc. Port	8015.1				
Feed/Conc. Port Retaining Ring	80051				
Adapter	8025				
Thrust Ring	8022.1			8022.2	
Strap	8027				
Strap Screw	8029				
Locking Segment Screw	8030				
Screw Spring	8031				
Saddle	8032				
Locking Kit Segment	8033				
Head O-ring	8037				
Sealing Plate O-ring(Inside)				8058	
Permeate Port O-ring	8040				
Permeate Port O-ring(Outside)				8062.1	
Feed/Concentrate Port O-ring	8041				
Adapter O-ring	8043				

ROPV Limited Warranty

Harbin ROPV Industry Development Center (hereinafter called "ROPV") vessels (the "Product") are warranted to the original purchaser (the "Customer") under normal use and if installed, operated and maintained in accordance with applicable User Guides to be free of defects in material and/or workmanship for a period of one (1) year from date of manufacture subject to the following. Any replacement Product or Part will be warranted only for the remainder of the original warranty period or thirty (30) days, whichever is longer.

Exclusions from this Limited Warranty

The warranty shall be void if:

1. defects are not reported during the warranty period.
2. the Product is subject to accident, damage, incorrect installation, mishandling, abuse, misuse, negligence or accident by any other party.
3. problems caused by modification or alteration.
4. chemical exposure or acts of nature.
5. any item manufactured by other companies.
6. wear on replaceable components under normal conditions – seals are excluded from this warranty.

Procedure for Obtaining Warranty Performance

ROPV reserves the right to determine if a reported defect is a breach of this warranty. This may require, at ROPV's discretion, one or more of the following: 1. an inspection or test of the Product and/or the system in which it was installed by an ROPV representative - the customer is responsible for arranging access to the Product. 2. an inspection or test of the product and/or the system in which it was installed by the Customer. 3. an inspection or test of the product and/or the system in which it was installed by third party inspector appointed by ROPV. 4. return of the Product to ROPV's factory for inspection or testing. This is not a statement of limitations for warranty performance and ROPV reserves the right to conduct warranty performance outside of the items shown.

If the Product is found by ROPV to be defective under the terms of this warranty, ROPV will perform one of the following at its option: 1. supply a substantially similar replacement part based on FOB factory terms. 2. conduct a field repair of the Product. 3. issue a credit for the original cost of the Products. This is not a statement of limitations for warranty performance and ROPV reserves the right to conduct warranty performance outside of the items shown.

Products returned to ROPV for inspection or testing must be shipped freight prepaid at the Customer's expense. If a breach of warranty is confirmed, ROPV will bear all costs related to the inspection and testing. If the Product failure is found to be caused by cause other than breach of warranty, all costs related to the inspection and testing of the Product will be borne by the Customer. This includes a USD\$500 per day fee and all related travel expenses.

All reported defects must be submitted to ROPV in writing.

Disclaimer

ROPV makes no expressed or implied warranty other than that specifically set forth in this warranty statement. ROPV disclaims any warranty of merchantability or of fitness for a particular purpose.

ROPV's liability under the terms of this warranty shall not exceed the purchase price of the Product which are claimed to be defective. ROPV shall not be liable for any consequential or incidental damages whatsoever, including but not limited to injuries or damages to person or property, loss of business profits, business interruption, loss of use, cost of removing/installing Products, or the claims of third parties.

Warranties or Representations by Others

No agent, employee, dealer, or other person has any authority to make any warranties or representations concerning ROPV or the Product. ROPV is not responsible for such claims of warranty or representation.

150
PSI

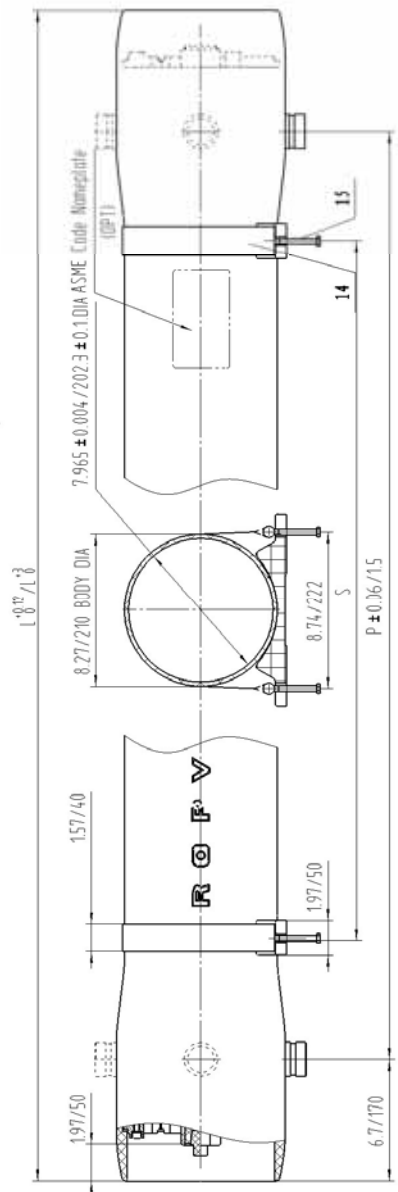
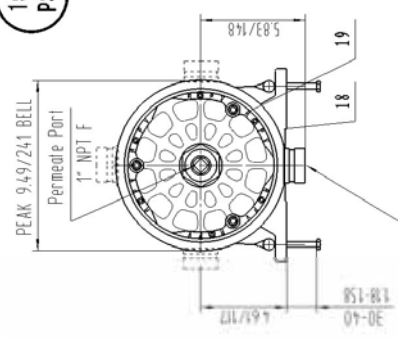

Feed/Conc Port
1.5" IPS Grooved

WARNING:

1. UNIT OF MEASURE INCHES/MM.
2. DRAWING DIMENSIONS ARE FOR REFERENCE ONLY.
3. PRECAUTIONS, USAGE GUIDELINES, AND USER GUIDE INTEGRAL TO DRAWING.
4. SUBJECT TO CHANGE WITHOUT NOTICE.
5. INTERNAL FERMENTE PRESSURE NOT TO EXCEED 125PSI(0.8Mpa).

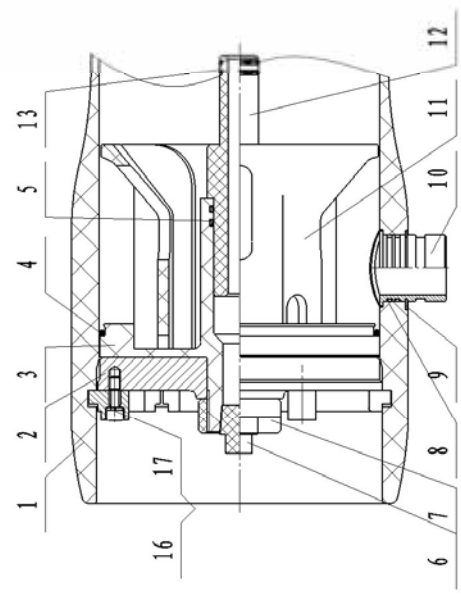

Ref. Part Number	Description	Qty.	Material
1	8001.1-7 Pressure Shell	1	Epoxy FRP
2	8011 Bearing Plate	2	Aluminum Alloy
3	8010.1 Sealing Plate	2	ABS
4	8037 O-Ring	2	EPDM
5	8040 O-Ring	4	EPDM
6	8013 Plug	1	ABS
7	8014.1 Permeate Port Locknut	2	ABS
8	8041 O-Ring	4	EPDM
9	80051 Retaining Ring	2	304SST
10	8015.1 1.5" Feed/Conc. Port	1-4	316L SST
11	8022.1 Thrust Ring	1	ABS
12	8025 Adapter	2	ABS
13	8043 O-Ring	4	EPDM
14	8027 Strap	2-3	304SST
15	8029 Strap Screw	4-6	304SST
16	8031 Screw Spring	6	304SST
17	8030 Locking Segment Screw	6	304SST
18	8032 Saddle	1-3	NI
19	8033 Locking Kit Segment	6	304SST

Shell length code	Shell L. O. A. IN/MM	L. P. IN/MM	Port to port IN/MM	S. Span IN/MM	Approx assembly weight LB/KG
1	8001.1 68.4/1534	47/1194	28/700	28/700	77.6/34.5
2	8001.2 104.4/2550	87/2210	57/1455	57/1455	88.9/39.5
3	8001.3 140.4/3556	127/3226	87/2204	87/2204	101.3/45
4	8001.4 180.4/4552	167/4241	63/1600 ±2	63/1600 ±2	112.5/50
5	8001.5 218.4/5538	207/5258	79/2000 ±2	79/2000 ±2	124.9/55.5
6	8001.6 248.4/6264	247/6274	93/2338 ±2	93/2338 ±2	137.3/61
7	8001.7 300.4/7630	287/7290	113/2865 ±2	113/2865 ±2	149.6/66.5

HARBIN ROPV
INDUSTRY DEVELOPMENT CENTER

DESIGN	JINSHI 01	DATE	2005/01/13	MODEL	R80B 150S
QTY	UTTER KING	DATE	2005/01/14	DWG	R80B15S-00
MARK	YUEJING LI	DATE	2005/01/14	REV	A

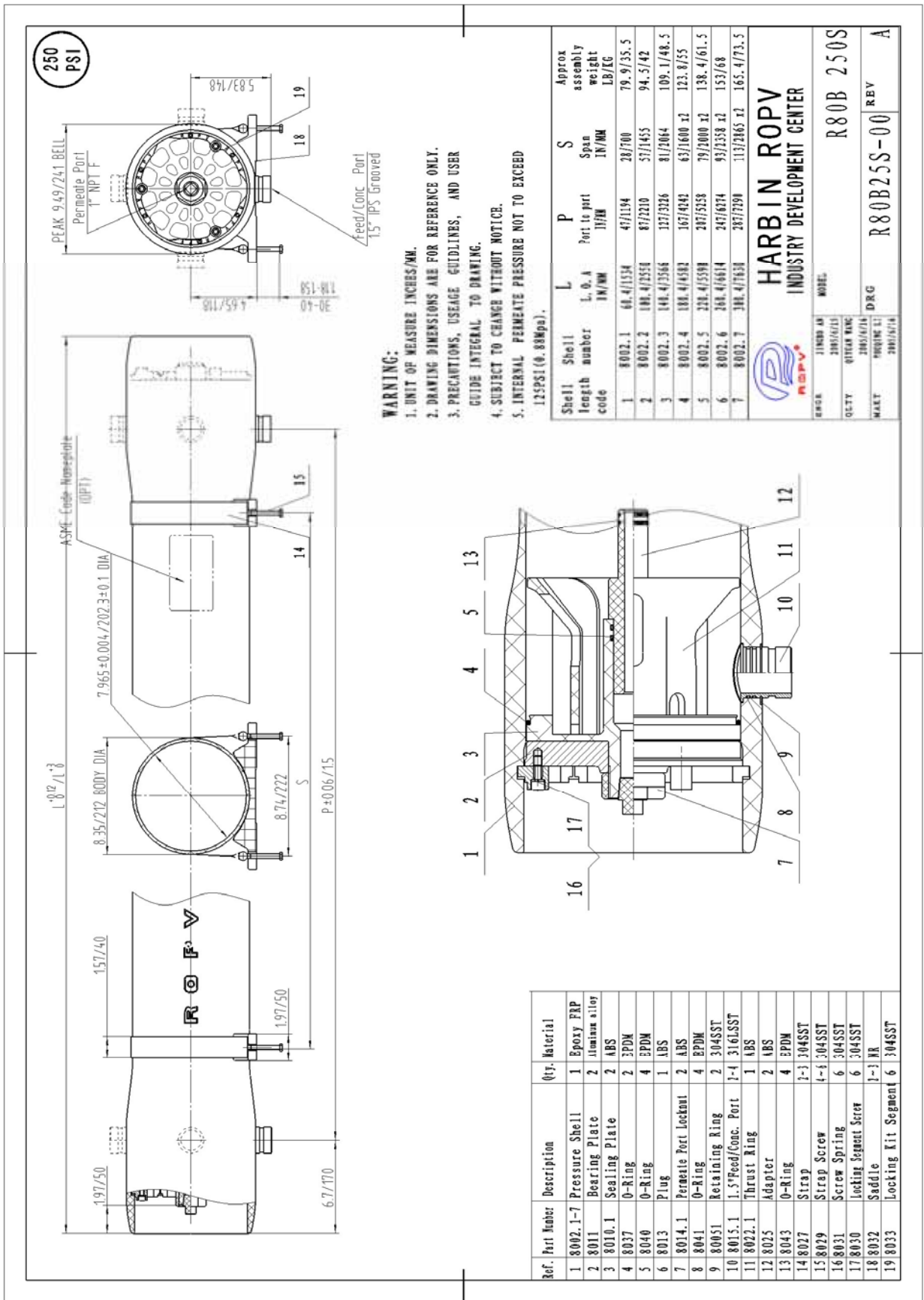

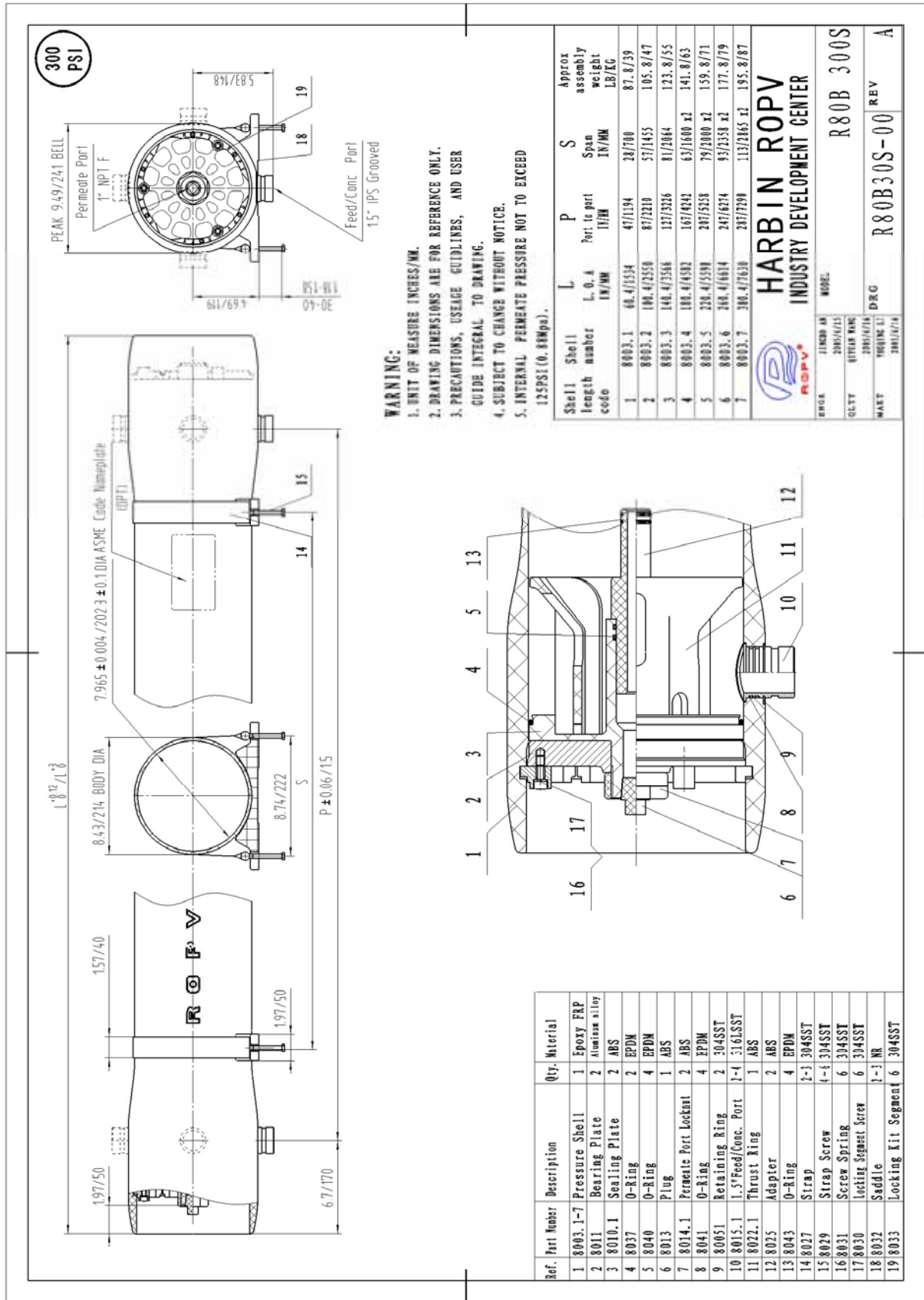

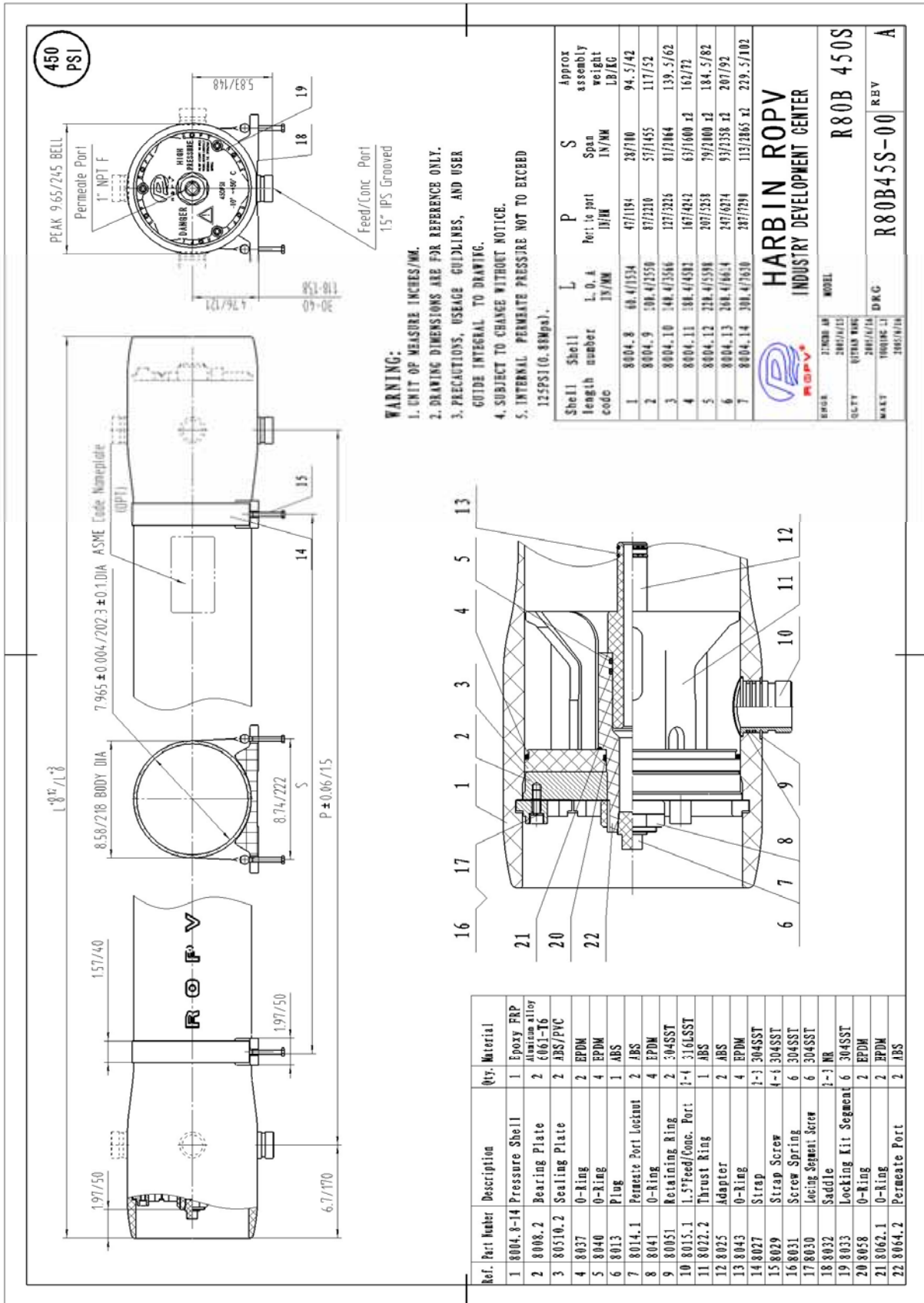

- WARNING:**
1. UNIT OF MEASURE INCHES/MM.
 2. DRAWING DIMENSIONS ARE FOR REFERENCE ONLY.
 3. PRECAUTIONS, USAGE GUIDELINES, AND USER GUIDE INTEGRAL TO DRAWING.
 4. SUBJECT TO CHANGE WITHOUT NOTICE.
 5. INTERNAL PERMEATE PRESSURE NOT TO EXCEED 125PSI (0.86mpa).

Shell length code	Shell number	L, O. A. IN/MM	P, Port. ID IN/MM	S, Span IN/MM	Approx assembly weight LB/KG
1	8004.8	68.4/1734	67/1194	287/100	94.5/42
2	8004.9	108.4/2750	87/2210	577/1455	117/52
3	8004.10	148.4/3766	127/3215	817/2064	139.5/62
4	8004.11	188.4/4782	167/4242	637/1600 ±2	162/72
5	8004.12	228.4/5798	207/5253	797/2000 ±2	184.5/82
6	8004.13	268.4/6814	247/6274	937/2358 ±2	207/92
7	8004.14	308.4/7830	287/7294	1137/2865 ±2	229.5/102

HARBIN ROPV
INDUSTRY DEVELOPMENT CENTER



MODEL		REV	
DATE	DESCRIPTION	DATE	DESCRIPTION
1998/11/11	2002/3/10	2005/1/11	2005/1/11
MAK	1998/11/11	DRG	R80B45S-00
			REV
			A

Ref. Part Number	Description	Qty.	Material
1	8004.8-14 Pressure Shell	1	Epoxy FRP
2	8008.2 Bearing Plate	2	Aluminum alloy
3	80510.2 Sealing Plate	2	6061-T6
4	8037 O-Ring	2	ABS/PVC
5	8040 O-Ring	2	EPDM
6	8013 Plug	1	EPDM
7	8014.1 Permeate Port Locknut	2	ABS
8	8041 O-Ring	4	EPDM
9	80051 Retaining Ring	2	304SS
10	8015.1 L-Feed/Conc. Port	1-1	316LSS
11	8022.2 Thrust Ring	1	ABS
12	8025 Adapter	2	ABS
13	8043 O-Ring	4	EPDM
14	8027 Strap	1-1	304SS
15	8029 Strap Screw	4-1	304SS
16	8031 Screw Spring	6	304SS
17	8030 Locking Segment Screw	6	304SS
18	8032 Saddle	1-1	NR
19	8033 Locking Kit Segment	6	304SS
20	8058 O-Ring	2	EPDM
21	8062.1 O-Ring	2	EPDM
22	8064.2 Permeate Port	2	ABS