

96M4296o

Full-size PICMG CPU Card

User's Manual

Edition 1.2

2009/7/14



Copyright

Copyright 2009, all rights reserved. This document is copyrighted and all rights are reserved. The information in this document is subject to change without prior notice to make improvements to the products.

This document contains proprietary information and protected by copyright. No part of this document may be reproduced, copied, or translated in any form or any means without prior written permission of the manufacturer.

All trademarks and/or registered trademarks contains in this document are property of their respective owners.

Disclaimer

The company shall not be liable for any incidental or consequential damages resulting from the performance or use of this product.

The company does not issue a warranty of any kind, express or implied, including without limitation implied warranties of merchantability or fitness for a particular purpose.

The company has the right to revise the manual or include changes in the specifications of the product described within it at any time without notice and without obligation to notify any person of such revision or changes.

Trademark

All trademarks are the property of their respective holders.

Any questions please visit our website at <http://www.commell.com.tw>

Packing List:

Please check the package content before you starting using the board.

Hardware:

96M4296o Full-size PICMG CPU Card x 1

Cable Kit:

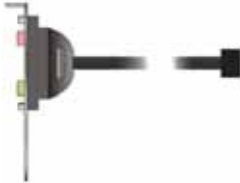

HD Audio Port Cable x 1



PS/2 Keyboard & Mouse Cable x 1



SATA Cable x 2



DVI module with DVI Cable x 1
(96M4296oXDG & 96M4296oXDG2)

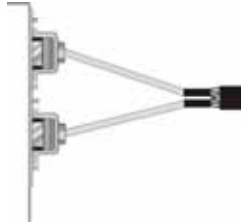

USB Cable x 2



FDD cable x 1



CPU Cooler x 1



40-pin ATA100 IDE cable x 1



ATX cable x 1

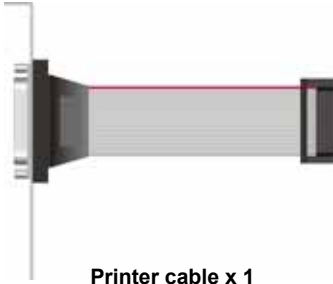

Printer cable x 1
(96M4296oXG2 & 96M4296oXDG2)

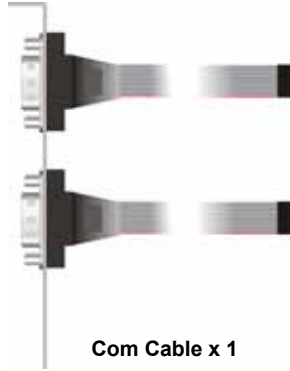

Com Cable x 1
(96M4296oXG2 & 96M4296oXDG2)

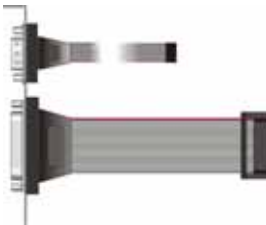

COM & Printer cable x 1
(96M4296oXG & 96M4296oXDG)

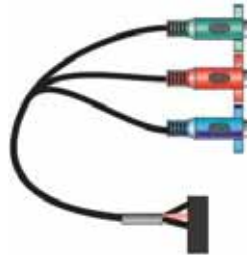

HDTV Port Cable x 1 (Optional)

Printed Matters:

Driver CD x 1 (including User's Manual)

VT-6421_RAID & ICH9M_AHCI disk driver x1

Index

Chapter 1 <Introduction>	7
1.1 <Product Overview>	7
1.2 <Product Specification>	8
1.3 <Mechanical Drawing>	10
1.4 <Block Diagram>	11
Chapter 2 <Hardware Setup>	12
2.1 <Connector Location>	12
2.2 <Connector Reference>	13
2.2.1 <Internal Connectors>	13
2.2.2 <External Connectors>	13
2.3 <Jumper Location & Reference>	14
2.4 <CPU and Memory Setup>	15
2.4.1 <CPU Setup>	15
2.4.2 <Memory Setup>	16
2.5 <CMOS Setup>	17
2.6 <Serial ATA Interface>	18
2.7 <Ethernet Interface>	19
2.8 <Onboard Display Interface>	20
2.8.1 <Analog VGA Interface>	20
2.8.2 <Digital Display>	21
2.8.3 <HDTV Interface>	25
2.8.4 <DVI Interface >	26
2.9 <Integrated Audio Interface>	27
2.10 <GPIO Interface>	29
2.11 <Power and Fan Installation>	30
2.11.1 <Power connectors>	30
2.11.2 <Fan Connectors>	30
2.11.3 <ATX Power Mode>	32
2.12 <Switch and Indicator>	33

Chapter 3 <System Setup>	34
3.1 <OS installation Guide>	34
3.2 <Audio Configuration>	35
3.3 <Video Memory Setup>	36
3.4 <Display Properties Setting>	37
Chapter 4 <BIOS Setup>	39
Appendix A <I/O Port Pin Assignment>	41
A.1 <Serial ATA Port>	41
A.2 <IrDA Port>	41
A.3 <SMBUS Port>	42
A.4 <Serial Port 2>	42
A.5 < RS-232, RS-422, RS-485 & IrDA >	43
A.6 <Parallel Port>	44
A.7 <LAN Port>	44
A.8 <USB Interface>	44
A.9 <DVI Port>	45
A.10 <PS/2 Keyboard & Mouse Port>	45
Appendix B <Flash BIOS>	46
B.1 <Flash Tool>	46
B.2 <Flash BIOS Procedure>	46
Appendix C <System Resources>	47
C.1 <Direct Memory Access (DMA)>	47
C.2 <Direct Memory Access (IRQ)>	47
C.3 <Input /Output (IO)>	48
C.4 <Memory Address Map>	50
Appendix D <Programming GPIO's>	51
Appendix E <Programming Watchdog Timer>	52

(This page is left for blank)

Chapter 1 <Introduction>

1.1 <Product Overview>

96M4296o the new generation of the Full-size PICMG CPU Card, supports Intel Penryn Processor for 667/800/1066 MHz front side bus and features Intel GM45 and ICH9M chipset, integrated GMA 4500MHD graphics, DDR3 memory, REALTEK ALC888 High Definition Audio, Serial ATA and two Intel Gigabit LAN.

Intel Penryn Processor

The board supports Intel Penryn processor with 667/800/1066 MHz front side bus, L2 Cache: All specification depends on the CPU(1M/2M/3M/4M/6M). To provides more powerful performance than before.

New features for Intel GM45 chipset

The board integrates Intel GM45 and ICH9M chipset, to provide new generation of the mobile solution, supports Intel GMA 4500MHD graphics, DDR3 800/1066MHz memory, built-in high-speed mass storage interface of serial ATA, High Definition Audio with 2 channels surrounding sound.

All in One multimedia solution

Based on Intel GM45 and ICH9M chipset, the board provides high performance onboard graphics, 24-bit dual channel LVDS interface, HDTV and 2 channels High Definition Audio, to meet the very requirement of the multimedia application.

Flexible Extension Interface

The board provides one PCI Express mini card (**96M4296oXDG & 96M4296oXDG2 only**), two PCI Express mini card (**96M4296oXG & 96M4296oXG2 only**) one mini-PCI socket and one CF socket.

1.2 <Product Specification>

General Specification

Form Factor	Full-size PICMG CPU Card PICMG version 1.0 (Rev. 2.0), PCI version 2.0 compliant
CPU	Support Intel Penryn Processor Package type: Micro-FCPGA478 (Socket-P) L2 Cache: All specification depends on the CPU (1M/2M/3M/4M/6M) Front side bus: 667/800/1066 MHz
Memory	2 x 800/1066MHz DDRIII 204-pin SO-DIMM up to 8GB
Chipset	Intel® GM45 and ICH9M (828011BM)
BIOS	Phoenix-Award v6.00PG 8Mb SPI flash BIOS
Green Function	Power saving mode includes doze, standby and suspend modes. ACPI version 2.0 and APM version 1.2 compliant
Watchdog Timer	System reset programmable watchdog timer with 1 ~ 255 sec./min. of timeout value
Real Time Clock	Chipset integrated RTC with onboard lithium battery
IDE	UltraATA133 IDE interface supports up to 2 ATAPI devices One 40-pin IDE port onboard with VT-6421
Serial ATA	Intel® ICH9M built-in 3 x SATAII interface up to 300MB/s VIA VT-6421 built-in 2 x SATAI interface up to 150MB/s (support RAID 0,1)

Multi-I/O Port

Chipset	Intel® ICH9M with Winbond® W83627DHG controller
Serial Port	Two RS232 and one jumper selectable RS232/422/485
Parallel Port	One internal bi-direction parallel port with SPP/ECP/EPP mode
Floppy Port	One internal Floppy port
USB Port	8 x Hi-Speed USB 2.0 ports with 480Mbps of transfer rate
IrDA Port	One IrDA compliant Infrared interface supports SIR
K/B & Mouse	PS/2 keyboard and mouse port on bracket
GPIO	One 12-pin Digital I/O connector with 8-bit programmable

VGA Display Interface

Chipset	Intel® GM45 & ICH9M
Memory	Up to 1024MB shared with system memory
Display Type	CRT, LCD monitor with analog display, DVI , HDTV
Connector	External DB15 female connector Onboard 40-Pin LVDS connector Onboard 26-Pin DVI connector (96M4296oXDG/XDG2) Onboard 9-Pin TV-out connector

Ethernet Interface

Chipset	Intel 82574L Gigabit Ethernet controller
Type	Triple speed 10/100/1000Base-T auto-switching Fast Ethernet Full duplex, IEEE802.3U compliant
Connector	External two RJ45 connector with LED on rear I/O panel

Audio Interface

Chipset	Intel® ICH9M with Realtek ALC888 HD Audio Intel High Definition Audio compliance
Interface	2 channels sound output
Connector	Internal 10-pin header for line-in/-out, MIC-in, 4-pin for CD-IN

Solid State Disk Interface

Flash Type	Compact Flash Typell for Compact Flash Card with VT-6421
------------	--

ISA Interface

ISA Bridge	Winbond W83628G & W83629G
Function	I/O & IRQ supported only, no support DMA & bus mastering

Expansive Interface

Mini PCI	Up to 2 x Mini PCI socket (optional) 1 x Mini PCI (standard)
PCI express	Up to 3 x PCI express mini card socket (optional)
Mini card	1 x PCI express mini card socket (96M4296oXDG/96M4296oXDG2) 2 x PCI express mini card socket (96M4296oXG/96M4296oXG2)

Power and Environment

Power Requirement	+5V, +12 DC input & 5V _{SB} Requirement
Dimension	338 (L) x 122 (W) mm
Temperature	Operating within 0 ~ 60 °C (32 ~ 140°F) Storage within -20 ~ 85 °C (-4 ~ 185°F)

Ordering Code

96M4296oXG	Onboard VGA, LVDS, HDTV, IDE, CF, SATA, COM, USB2.0, Mini PCI, HD Audio, 2 x PCI Express mini card, 1 x Gigabit LAN.
96M4296oXG2	Onboard VGA, LVDS, HDTV, IDE, CF, SATA, COM, USB2.0, Mini PCI, HD Audio, 2 x PCI Express mini card, 2 x Gigabit LAN.
96M4296oXDG	Onboard VGA, LVDS, HDTV, IDE, CF, SATA, COM, USB2.0, Mini PCI, HD Audio, DVI, 1 x PCI Express mini card, 1 x Gigabit LAN.
96M4296oXDG2	Onboard VGA, LVDS, HDTV, IDE, CF, SATA, COM, USB2.0, Mini PCI, HD Audio, DVI, 1 x PCI Express mini card, 2 x Gigabit LAN.

1.3 <Mechanical Drawing>

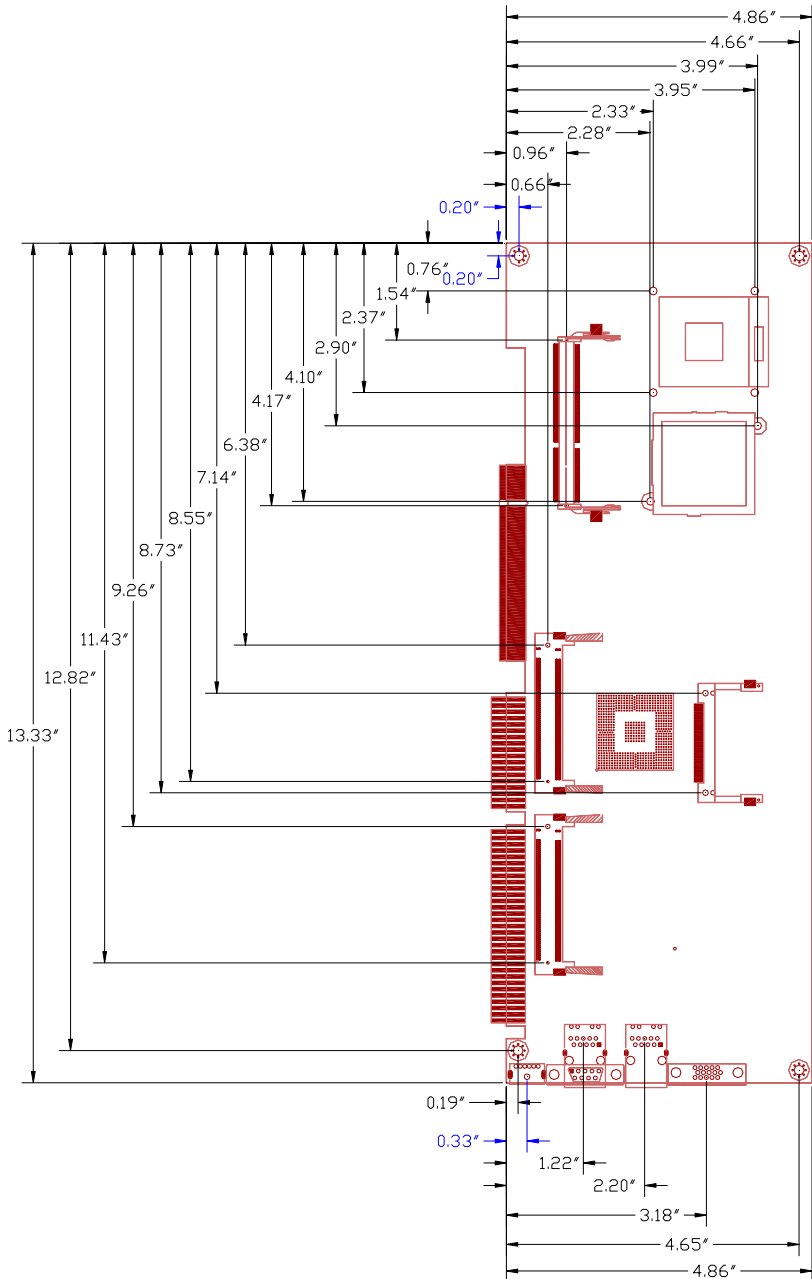

1.4 <Block Diagram>

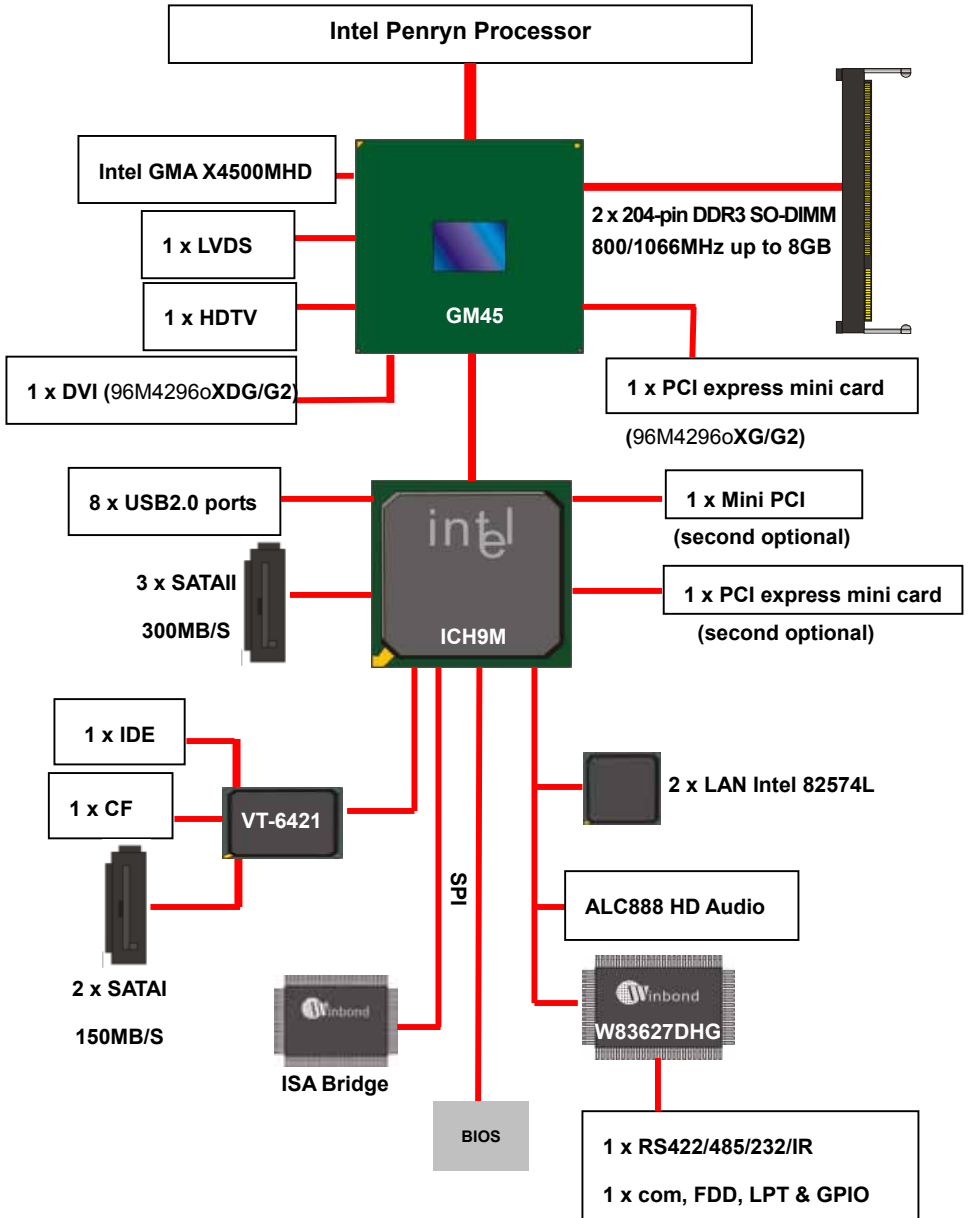

Chapter 2 <Hardware Setup>

2.1 <Connector Location>

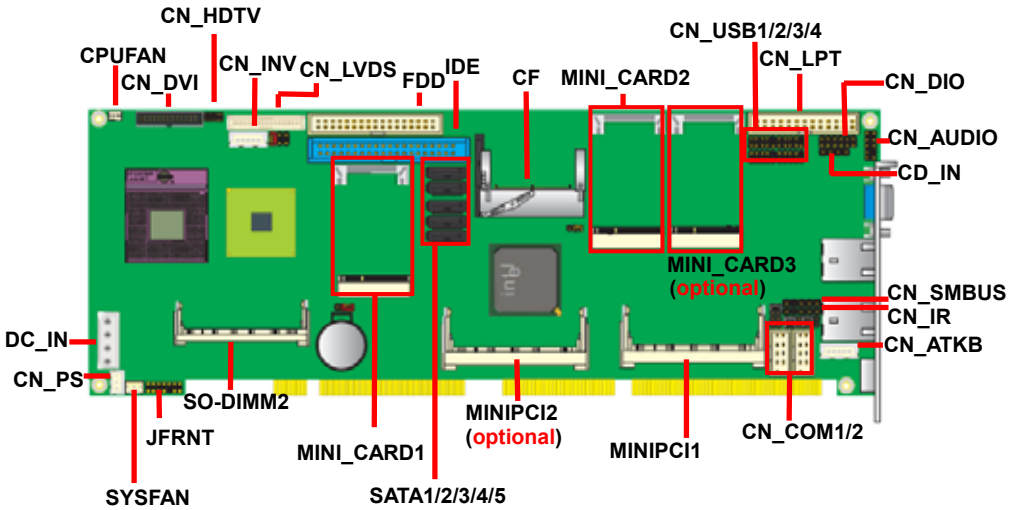

96M4296oXG2 & 96M4296oXDG2

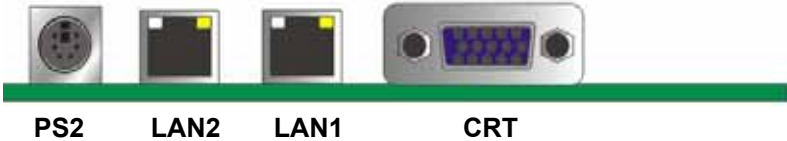

96M4296oXG & 96M4296oXDG



2.2 <Connector Reference>

2.2.1 <Internal Connectors>

Connector	Function	Remark
CPU	Socket 478 for socket-P CPU	
SO-DIMM1/2	204-pin DDR3 SO-DIMM socket	
IDE	40-pin primary IDE connector	
CN_LPT	26-pin LPT port connector	
FDD	34-pin floppy connector	
SATA1/2/3/4/5	7-pin Serial ATA connector	
DC_IN	4-pin AT power supply connector	
CN_PS	3-pin power input connector	
CN_AUDIO	5 x 2-pin audio connector	
CD_IN	4-pin CD-ROM audio input connector	
CN_DIO	6 x 2-pin digital I/O connector	
CN_USB	5 x 2-pin USB connector	
CPUFAN	4-pin CPU cooler fan connector	
SYSFAN	3-pin system cooler fan connector	
CN_DVI	13 x 2-pin DVI interface	(96M4296oXDG/G2)
CN_HDTV	5 x 2-pin HDTV interface	
CN_LVDS	20 x 2-pin LVDS connector	
CN_INV	5-pin LCD inverter connector	
CN_IR	5-pin IrDA connector	
CN_ATKB	5-pin AT keyboard connector	
JFRNT	14-pin front panel switch/indicator connector	
MiniPCI	124-pin Mini-PCI socket Type IIIA	
PCI express mini card	52-pin PCI express mini card socket	
COM 1/2	Serial port 1/2 connector	(96M4296oXG2/XDG2)
COM 2	Serial port 2 connector	(96M4296oXG/XDG)

2.2.2 <External Connectors>

Connector	Function	Remark
CRT	DB15 VGA connector	
PS2	PS2 keyboard & mouse	
RJ45_1/2	RJ45 LAN 1/2 connector	(96M4296oXG2/XDG2)
RJ45_1	RJ45 LAN 1 connector	(96M4296oXG/XDG)
COM 1	Serial port 1 connector	(96M4296oXG/XDG)

2.3 <Jumper Location & Reference>

Jumper	Function
JRTC	CMOS Operating/Clear Setting
JVLCD	Panel Voltage Setting
JAT	Power mode select
JCSEL1/2	CN_COM2 RS-232 RS422 RS485 Setting / CN_IR IrDA Setting

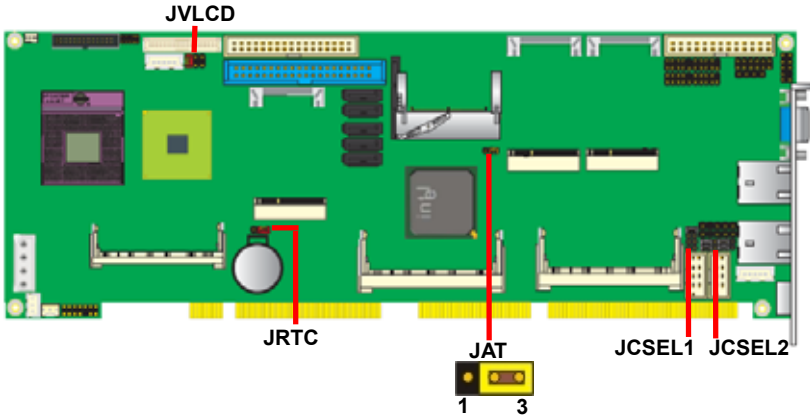

Jumper: **JAT**

Type: onboard 3-pin header

JAT	Mode
1-2	AT Mode
2-3	ATX Mode

Default setting: 2-3

2.4 <CPU and Memory Setup>

2.4.1 <CPU Setup>

The board comes with the socket 478 for Intel Core 2 Duo **socket-P** processor only it supports new generation with 667/800/1066 MHz of front side bus. Please follow the instruction to install the CPU properly.

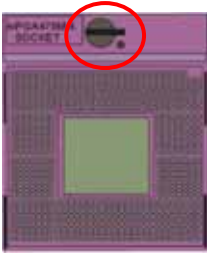

1. Use the flat-type screw drive to unlock the CPU socket



Unlock way

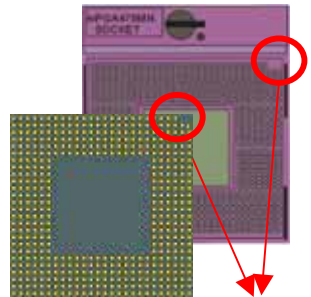

Check point

2. Follow the pin direction to install the processor on the socket

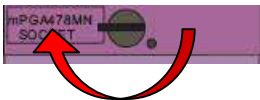

3. Lock the socket

4. Socket P has 478 pins, but is not pin-compatible with Socket P CPU.

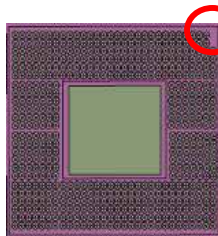

Socket-P CPU
Check point

2.4.2 <Memory Setup>

The board provides two 204-pin DDR3 SO-DIMM to support 800/1066 MHz memory module up to 8GB. Non-ECC, unbuffered memory is supported only, dual channel technology is enabled automatically for higher performance.

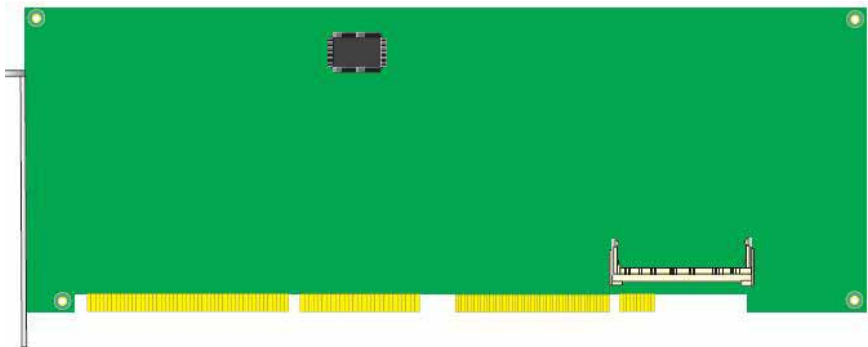
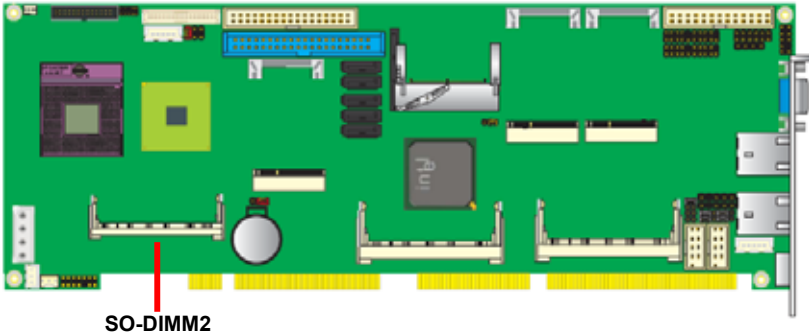

2.5 <CMOS Setup>

The board's data of CMOS can be setting in BIOS. If the board refuses to boot due to inappropriate CMOS settings, here is how to proceed to clear (reset) the CMOS to its default values.

Jumper: JRTC

Type: Onboard 3-pin jump

JRTC	Mode
1-2	Clear CMOS
2-3	Normal Operation

Default setting: 2-3

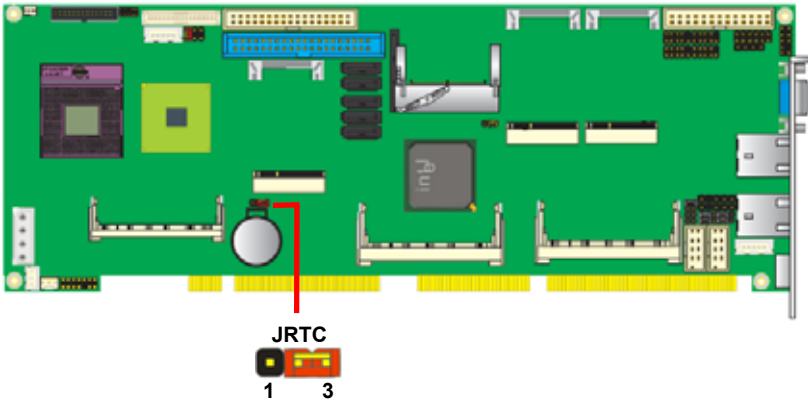

2.6 <Serial ATA Interface>

Based on Intel ICH9M, the board provides three Serial ATAII interfaces with up to 300MB/s of transfer rate and support AHCI.

Based on VIA VT-6421, the board provides two Serial ATAI interfaces with up to 150MB/s of transfer rate and support RAID 0,1.

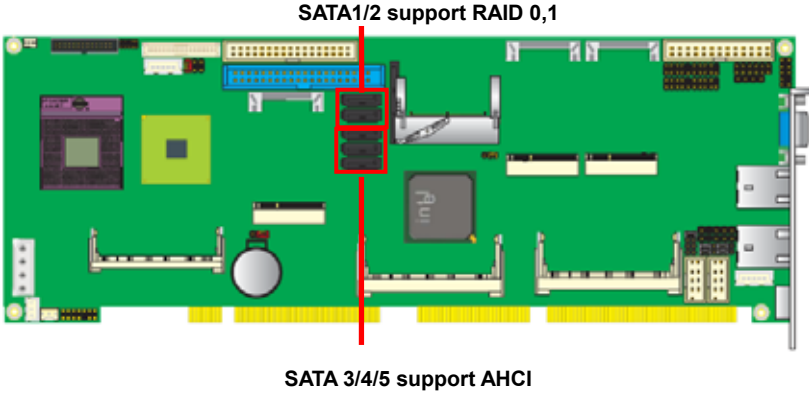

2.7 <Ethernet Interface>

The board integrates with two Intel 82574L Gigabit Ethernet controllers. The Intel Gigabit Ethernet supports triple speed of 10/100/1000Base-T, with IEEE802.3 compliance and Wake-On-LAN supported.

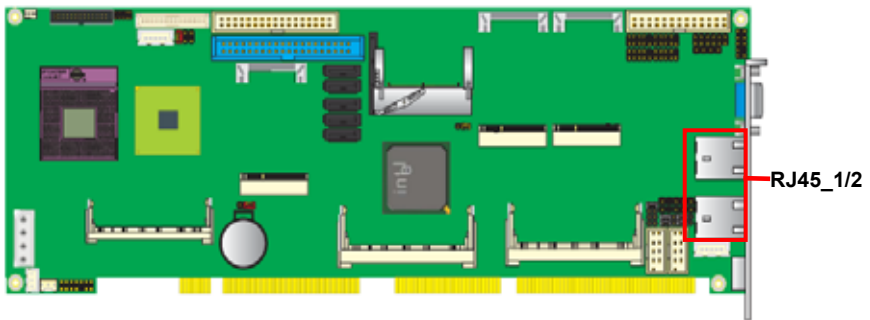

2.8 <Onboard Display Interface>

Based on Intel GM45 chipset with built-in GMA (Graphic Media Accelerator) 4500MHD graphics, the board provides, 40-pin LVDS interface with 5-pin LCD backlight inverter connector. The board provides dual display function with clone mode and extended desktop mode for VGA, LVDS, HDTV and DVI.

2.8.1 <Analog VGA Interface>

Please connect your CRT or LCD monitor with DB15 male connector to the onboard DB15 female connector on rear I/O port.



2.8.2 <Digital Display>

The board provides one 40-pin LVDS connector up to two mode for 18/24-bit single/dual channel panels, supports up to 1920 x 1200 (UXGA) resolution, with LCD backlight inverter connector and jumper for panel voltage setting.

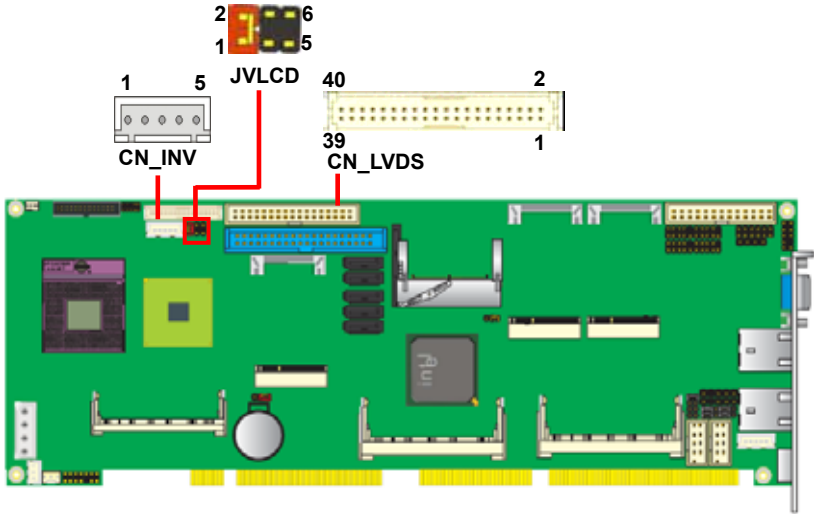

Effective patterns of connection: 1-2 / 3-4 / 5-6



Warning: others cause damages

Connector: **CN_INV**

Type: 5-pin LVDS Power Header

Connector model: **JST B5B-XH-A**

Pin	Description
1	+12V
2	Reserved (Note)
3	GND
4	GND
5	ENABKL

Note: Reserved for MB internal test
Please treat it as NC.

Connector: **JVLCD**

Type: 6-pin Power select Header

Pin	Description
1-2	LCDVCC (3.3V)
3-4	LCDVCC (5V)
5-6	LCDVCC (12V)

Default: 1-2

Connector: **CN_LVDS**

Type: onboard 40-pin connector for LVDS connector

Connector model: **HIROSE DF13-40DP-1.25V**

Pin	Signal	Pin	Signal
2	LCDVCC	1	LCDVCC
4	GND	3	GND
6	ATX0-	5	BTX0-
8	ATX0+	7	BTX0+
10	GND	9	GND
12	ATX1-	11	BTX1-
14	ATX1+	13	BTX1+
16	GND	15	GND
18	ATX2-	17	BTX2-
20	ATX2+	19	BTX2+
22	GND	21	GND
24	ACLK-	23	BTX3-
26	ACLK+	25	BTX3+
28	GND	27	GND
30	ATX3-	29	BCLK-
32	ATX3+	31	BCLK+
34	GND	33	GND
36	DDCPCLK	35	N/C
38	DDCPDATA	37	N/C
40	N/C	39	N/C

96M4296o User's Manual

To setup the LCD, you need the component below:

1. A panel with LVDS interfaces.
2. An inverter for panel's backlight power.
3. A LCD cable and an inverter cable.

For the cables, please follow the pin assignment of the connector to make a cable, because every panel has its own pin assignment, so we do not provide a standard cable; please find a local cable manufacture to make cables.

LCD Installation Guide:

1. Preparing the **96M4296o**, **LCD panel** and the **backlight inverter**.

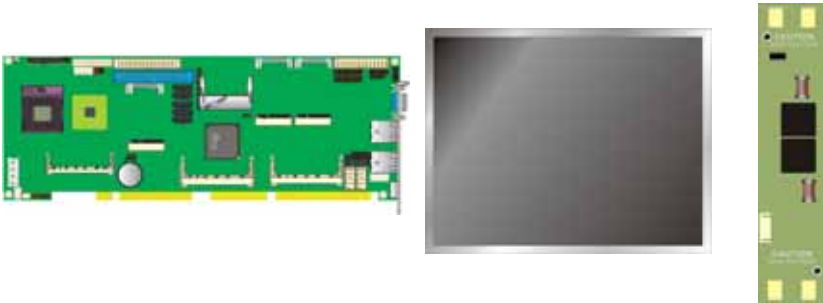

2. Please check the datasheet of the panel to see the voltage of the panel, and set the jumper **JVLCD** to +12V or +5V or +3.3V.
3. You would need a LVDS type cable.



4. To connect all of the devices well.

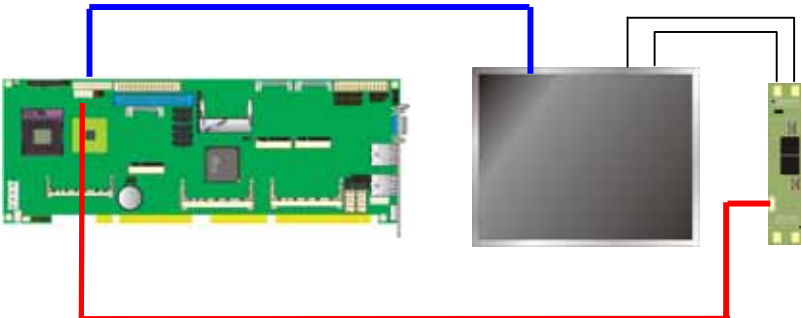

After setup the devices well, you need to select the LCD type in the BIOS.

The panel type mapping is list below:

BIOS panel type selection form (BIOS Version:1.0)			
	18-bit Single channel		24-bit Dual channel
NO.	Output format	NO.	Output format
1	640 x 480	11	1280 x 768
2	800 x 480	12	1280 x 1024
3	800 x 600	13	1600 x 1200
4	1024 x 768	14	1920 x 1080
5	1280 x 800	15	1920 x 1200
	18-bit Dual channel		
6	1280 x 768		
	24-bit Single channel		
7	1024 x 768		
8	1280 x 768		
9	1280 x 800		
10	1366 x 768		

2.8.3 <HDTV Interface>

The board provides an HDTV interface with Intel GM45, supports Composite, S-Video and Component with PAL and NTSC of TV system, and display (clone or extended desktop) function with VGA, LVDS, DVI.

Connector: **CN_HDTV**



Connector type: 10-pin header HDTV connector (pitch = 2.54mm)

Pin Number	Assignment	Pin Number	Assignment
1	GND	2	DACB_L
3	DACC_L	4	GND
5	GND	6	N/C
7	DACA_L	8	GND
9	N/C	10	N/C

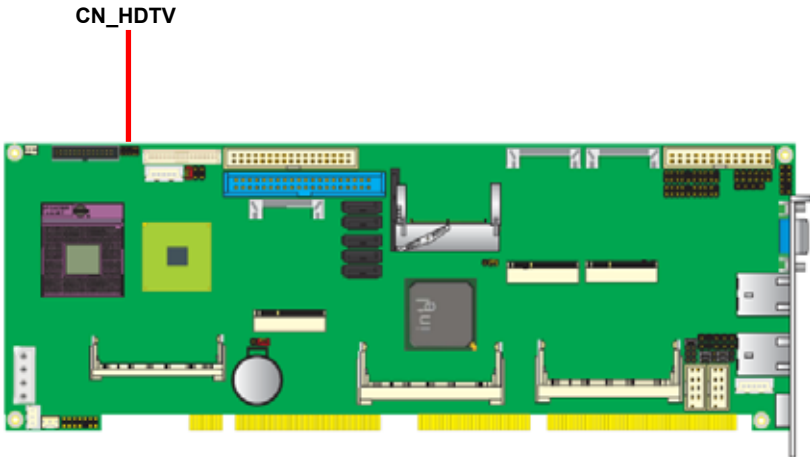

2.8.4 <DVI Interface >

The board also comes with a DVI interface with Chronitel CH7318C for digital video interface.

Connector: **CN_DVI**

Connector type: 26-pin header connector (pitch = 2.00mm)

Pin Number	Assignment	Pin Number	Assignment
1	TX1+	2	TX1-
3	Ground	4	Ground
5	TXC+	6	TXC-
7	Ground	8	PVDD
9	N/C	10	N/C
11	TX2+	12	TX2-
13	Ground	14	Ground
15	TX0+	16	TX0-
17	N/C	18	HPDET
19	DCCDATA	20	DCCCLK
21	GND	22	N/C
23	N/C	24	N/C
25	N/C	26	N/C

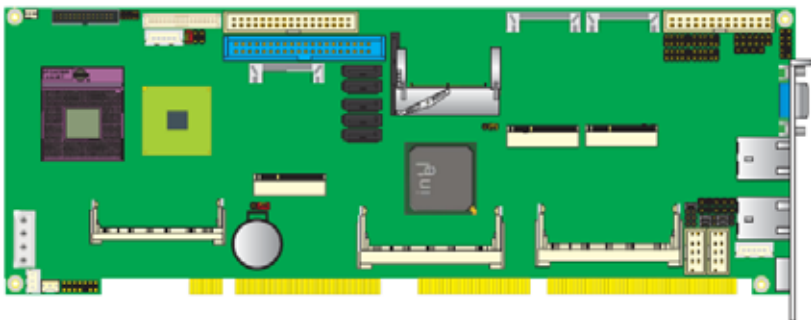

2.9 <Integrated Audio Interface>

The board integrates onboard audio interface with REALTEK ALC888 codec, with Intel next generation of audio standard as High Definition Audio, it offers more sound and other advantages than former HD audio compliance.

The main specifications of ALC888 are:

- **High-performance DACs with 97dB SNR (A-Weighting),**
- **Ten DAC channels support 16/20/24-bit PCM format for 2 sound playback, plus 2 channels of independent stereo sound output (multiple streaming) through the front panel output**
- **High-quality analog differential CD input**
- **Meets performance requirements for Microsoft WLP 3.0 Premium desktop and mobile PCs**

The board provides 2 channels audio speaker out and Mic-In ports for front I/O panel through cable.

Connector: CN_AUDIO

Type: 10-pin (2 x 5) 2.54mm-pitch header



Pin	Description	Pin	Description
1	MIC2_L	2	Ground
3	MIC2_R	4	VCC
5	FP_OUT_R	6	MIC2_JD
7	SENSE_B	8	N/C
9	FP_OUT_L	10	LINE2_JD



Connector: CD_IN

Type: 4-pin header (pitch = 2.54mm)

Pin	Description
1	CD – Left
2	Ground
3	Ground
4	CD – Right

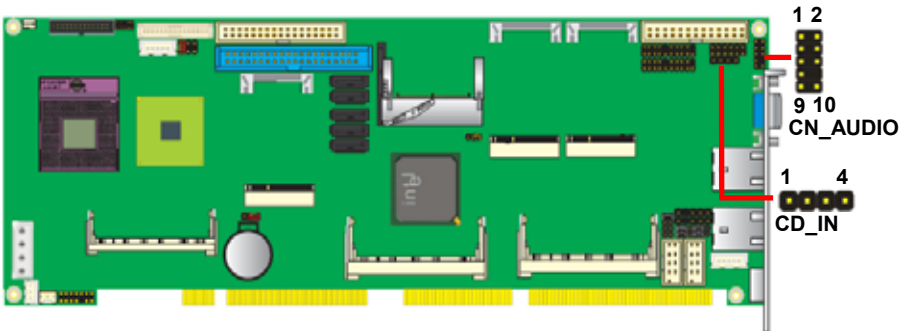

2.10 <GPIO Interface>

The board provides a programmable 8-bit digital I/O interface; you can use this general purpose I/O port for system control like POS or KIOSK.

Connector: **CN_DIO**

Type: 12-pin (6 x 2) 2.0mm-pitch header



Pin	Description	Pin	Description
1	Ground	2	Ground
3	GP10	4	GP14
5	GP11	6	GP15
7	GP12	8	GP16
9	GP13	10	GP17
11	VCC	12	+12V

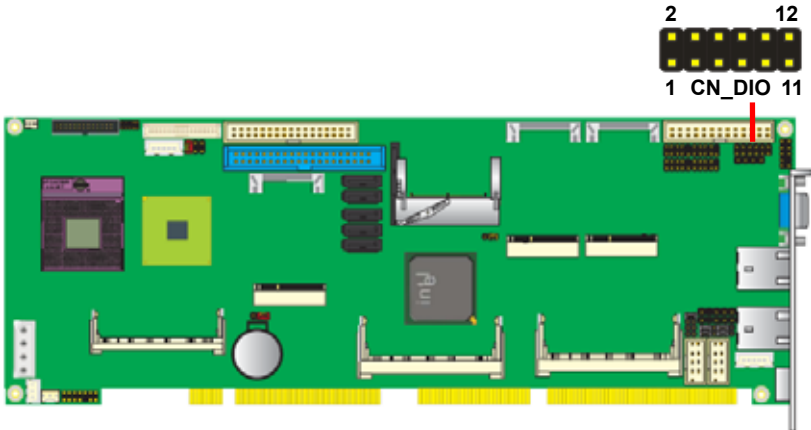

2.11 <Power and Fan Installation>

The board comes with a 4-pin AT power connector for powering the board, three fan connectors for Northbridge, CPU and system. The board also provides a 3-pin ATX function connector. You can just connect the two power connectors without any backplane to work.

2.11.1 <Power connectors>

Connector: **DC_IN**

Type: 4-pin P-type connector for +5V/+12V input

Pin	Description	Pin	Description	Pin	Description	Pin	Description
1	+12V	2	Ground	3	Ground	4	+5V

Connector: **CN_PS**

Type: 3-pin ATX function connector

Pin	Description	Pin	Description	Pin	Description
1	5V Standby	2	Ground	3	Power On

2.11.2 <Fan Connectors>

Connector: **CPUFAN**

Type: 4-pin fan wafer connector

Pin	Description	Pin	Description
1	Ground	2	+12V
3	Fan Speed Detection	4	Fan Control

Connector: **SYSFAN**

Type: 3-pin fan wafer connector

Pin	Description	Pin	Description	Pin	Description
1	Ground	2	+12V	3	Fan Speed Detection

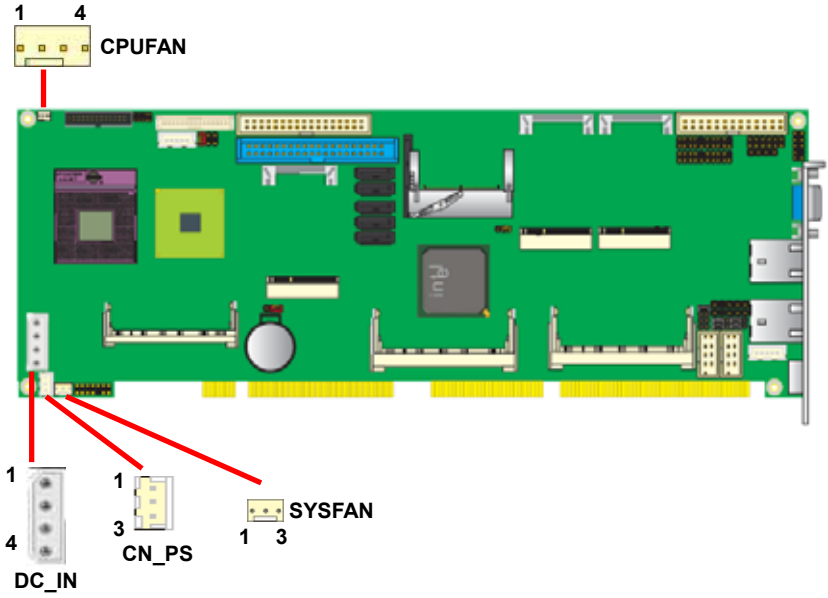

2.11.3 <ATX Power Mode>

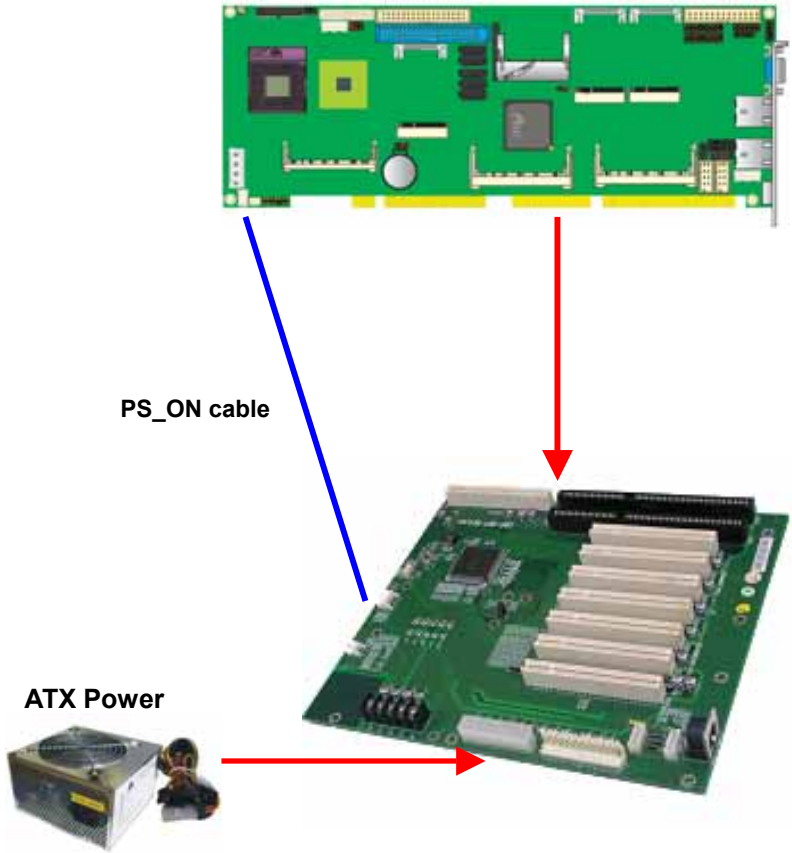

2.12 <Switch and Indicator>

The **JFRNT** provides front control panel of the board, such as power button, reset and beeper, etc. Please check well before you connecting the cables on the chassis.

Connector: **JFRNT**

Type: onboard 14-pin (2 x 7) 2.54-pitch header

Function	Signal	PIN		Signal	Function
IDE LED	HDLED+	1	2	PWRLED+	Power LED
	HDLED-	3	4	N/C	
Reset	Reset+	5	6	PWRLED-	Speaker
	Reset-	7	8	SPK+	
N/C		9	10	N/C	
Power Button	PWRBT-	11	12	N/C	
	PWRBT+	13	14	SPK-	

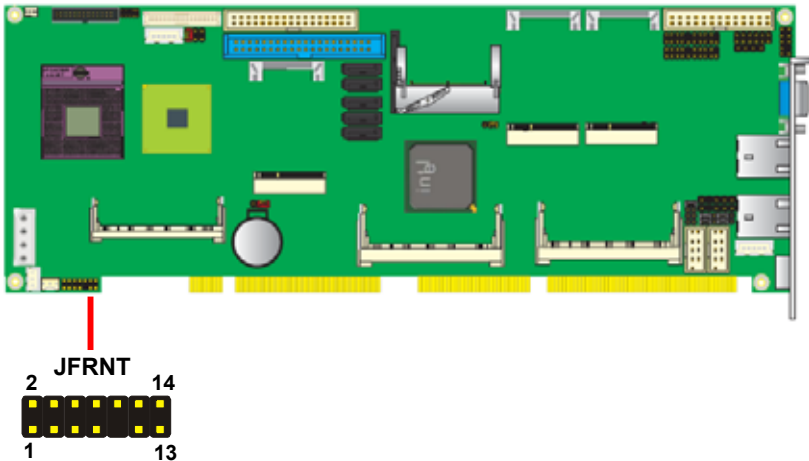

Chapter 3 <System Setup>

3.1 <OS installation Guide>

In this card, the functions IDE, CF and SATA1/2 (RAID 0,1) are driven by VIA VT-6421. To activate and to use these features, users must install drivers when installing OS.

IDE & CF & SATA1/2 built-in with VT-6421

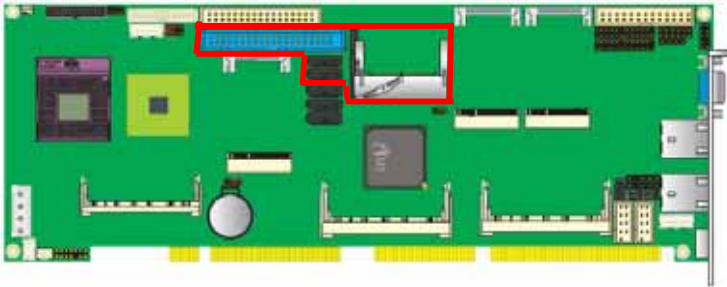

To take windows XP installation as an example, please DO the following steps:

1. Please insert VT-6421 floppy driver disk.
2. Boot the system with windows XP installation CD to start to install OS.
3. When you see the bottom message, said "Press F6 if you need to install a third party SCSI or RAID driver," please DO Press F6. **(Refer to photo A.)**
4. After the system finishes loading all necessary drivers, here comes with a screen message to ask you press "S" to specify additional device to load VT-6421 drivers. **(Refer to photo B.)**
5. Please choose the option of VT-6421 XP driver. **(Refer to photo C.)**
6. Please press "ENTER" to continue installing OS.



Photo A.

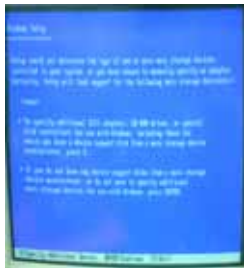

Photo B.



Photo C.

3.2 <Audio Configuration>

The board integrates Intel® ICH9M with REALTEK® ALC888 codec. It can support 2 channels sound under system configuration. Please follow the steps below to setup your sound system.

1. Install REALTEK HD Audio driver.
2. Lunch the control panel and Sound Effect Manager.



3. Select Speaker Configuration



4. Select the sound mode to meet your speaker system.

3.3 <Video Memory Setup>

Based on Intel® GM45 chipset with GMA (Graphic Media Accelerator) 4500MHD, the board supports Intel® DVMT (Dynamic Video Memory Technology) 4.0, which would allow the video memory to be allocated up to 1024MB.

To support DVMT, you need to install the Intel GMA 4500MHD Driver with supported OS.

BIOS Setup:



Total GFX Memory Size:

This item can let you select a static amount of page-locked graphics memory which will be allocated during driver initialization. Once you select the memory amount, it will be no longer available for system memory.

DVMT Mode: This item can let you select graphics memory

3.4 <Display Properties Setting>

Based on Intel GM45 GMCH with GMA 4500MHD (Graphic Media Accelerator), the board supports two DACs for display device as different resolution and color bit. Please install the Intel Graphic Driver before you starting setup display devices.

1. Click right button on the desktop to lunch **display properties**



2. Click **Advanced** button for more specificity setup.



Click **Graphics Properties...** for advanced setup

3. This setup options can let you define each device settings.

Click **Monitor** to setup the CRT monitor for Colors, Resolution and Refresh Rate

Click **Intel(R) Dual Display Clone** to setup the dual display mode as same screen

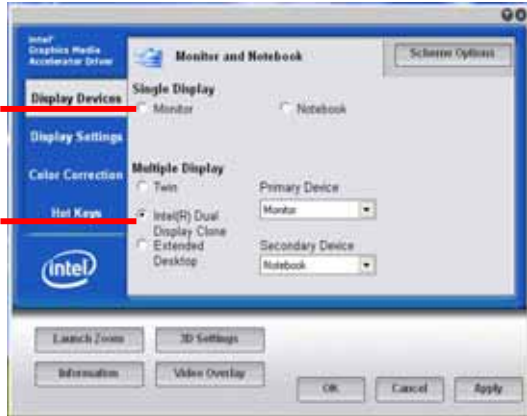

Chapter 4 <BIOS Setup>

The motherboard uses the Award BIOS for the system configuration. The Award BIOS in the single board computer is a customized version of the industrial standard BIOS for IBM PC AT-compatible computers. It supports Intel x86 and compatible CPU architecture based processors and computers. The BIOS provides critical low-level support for the system central processing, memory and I/O sub-systems.

The BIOS setup program of the single board computer let the customers modify the basic configuration setting. The settings are stored in a dedicated battery-backed memory, NVRAM, retains the information when the power is turned off. If the battery runs out of the power, then the settings of BIOS will come back to the default setting.

The BIOS section of the manual is subject to change without notice and is provided here for reference purpose only. The settings and configurations of the BIOS are current at the time of print, and therefore they may not be exactly the same as that displayed on your screen.

To activate CMOS Setup program, press key immediately after you turn on the system. The following message "Press DEL to enter SETUP" should appear in the lower left hand corner of your screen. When you enter the CMOS Setup Utility, the Main Menu will be displayed as **Figure 4-1**. You can use arrow keys to select your function, press <Enter> key to accept the selection and enter the sub-menu.

Figure 4-1 CMOS Setup Utility Main Screen

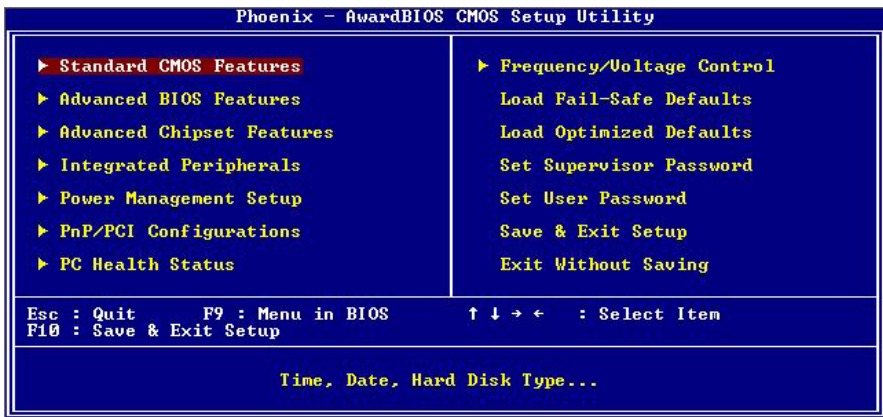

(This page is left for blank)

Appendix A <I/O Port Pin Assignment>

A.1 <Serial ATA Port>

Connector: **SATA1/2/3/4/5**

Type: 7-pin wafer connector

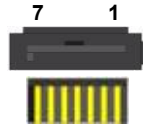

1	2	3	4	5	6	7
GND	SATA_TXP0	SATA_TXN0	GND	SATA_RXN0	SATA_RXP0	GND

A.2 <IrDA Port>

Connector: **CN_IR**

Type: 5-pin header for SIR Ports

Pin	Description
1	VCC
2	N/C
3	IRRX
4	Ground
5	IRTX



JCSEL1 must jump to "IrDA"

A.3 <SMBUS Port>

Connector: **CN_SMBUS**

Type: 5-pin header for SMBUS Ports

Pin	Description
1	V5S
2	N/C
3	SMBDATA
4	SMBCLK
5	Ground



A.4 <Serial Port 2>

Connector: **CN_COM2**

Type: 9-pin box header

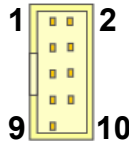

Pin	Description	Pin	Description
1	DCD/422TX-/485-/ +5V	2	RX/422TX+/485+
3	TX/422RX+	4	DTR/422RX-
5	Ground	6	DSR
7	RTS	8	CTS
9	RI /+12V		

A.5 < RS-232, RS-422, RS-485 & IrDA >

Function	JCSEL1	JCSEL2
IrDA		
RS-422		
RS-485		
RS-232		

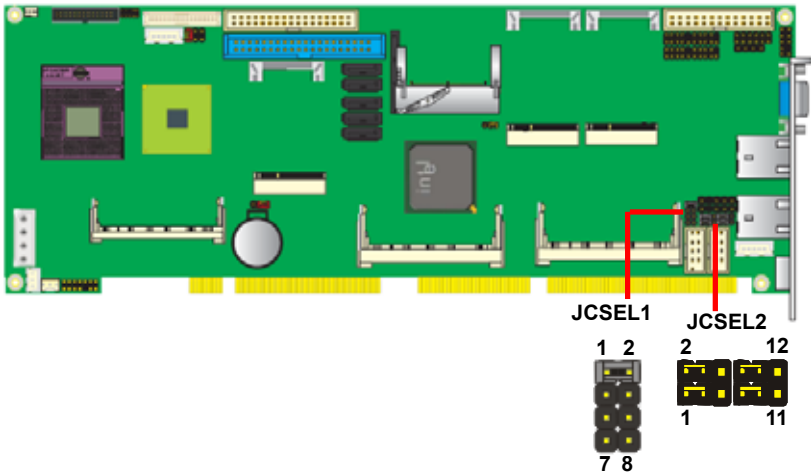

A.6 <Parallel Port>

Connector: **LPT**

Type: 26-Pin box header

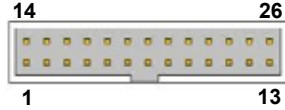

Pin	Description	Pin	Description
1	-PSTB	14	AFD-
2	PRO0	15	ERR-
3	PRO1	16	INT-
4	PRO2	17	SLIN-
5	PRO3	18	Ground
6	PRO4	19	Ground
7	PRO5	20	Ground
8	PRO6	21	Ground
9	PRO7	22	Ground
10	ACK-	23	Ground
11	BUSY	24	Ground
12	PE	25	Ground
13	SLCT	26	N/C

A.7 <LAN Port>

Connector: **RJ45_1/2**

Type: RJ45 connector with LED



Pin	1	2	3	4	5	6	7	8
Description	MI0+	MI0-	MI1+	MI2+	MI2-	MI1-	MI3+	MI3-

A.8 <USB Interface>

Connector: **CN_USB 1/2/3/4**

Type: 10-pin (5 x 2) header for dual USB Ports

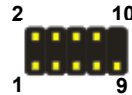

Pin	Description	Pin	Description
1	VCC	2	VCC
3	Data0-	4	Data1-
5	Data0+	6	Data1+
7	Ground	8	Ground
9	Ground	10	N/C

A.9 <DVI Port>

Connector: **CN_DVI**

Type: onboard 26-pin connector for DVI connector



Pin	Description	Pin	Description
1	TDC1+	2	TDC1-
3	GND	4	GND
5	TLC+	6	TLC-
7	GND	8	V5S
9	N/C	10	N/C
11	TDC2+	12	TDC2-
13	GND	14	GND
15	TDC0+	16	TDC0-
17	N/C	18	HPD
19	DVI_DA	20	DVI_SL
21	GND	22	BR
23	BG	24	BB
25	5HSYNC	26	5VSYNC

A.10 <PS/2 Keyboard & Mouse Port>

Connector: **PS2**

Type: 6-pin Mini-DIN connector on bracket

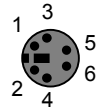

Pin	1	2	3	4	5	6
Description	KBD	MSD	Ground	VCC	KBC	MSC

Note: The PS/2 connector supports standard PS/2 keyboard directly or both PS/2 keyboard and mouse through the PS/2 Y-type cable.

Appendix B <Flash BIOS>

B.1 <Flash Tool>

The board is based on Award BIOS and can be updated easily by the BIOS auto flash tool. You can download the tool online at the address below:

<http://www.phoenix.com/en/home/>

http://www.commell.com.tw/Support/Support_SBC.htm

File name of the tool is "awdfash.exe", it's the utility that can write the data into the BIOS flash chip and update the BIOS.

B.2 <Flash BIOS Procedure>

1. Please make a bootable floppy disk.
2. Get the last .bin files you want to update and copy it into the disk.
3. Copy awardflash.exe to the disk.
4. Power on the system and flash the BIOS. (Example: C:/ awdfash XXX.bin)
5. Restart the system.

Any question about the BIOS re-flash please contact your distributors or visit the web-site at below:

<ftp://ftp.commell.com.tw/COMMELL/support/AWDFLASH.rar>

Appendix C <System Resources>

C.1 <Direct Memory Access (DMA)>

-  2 Standard floppy disk controller
-  4 Direct memory access controller

C.2 <Direct Memory Access (IRQ)>

- (ISA) 0 High precision event timer
- (ISA) 1 Standard 101/102-Key or Microsoft Natural PS/2 Keyboard
- (ISA) 3 Communications Port (COM2)
- (ISA) 4 Communications Port (COM1)
- (ISA) 6 Standard floppy disk controller
- (ISA) 8 High precision event timer
- (ISA) 9 Microsoft ACPI-Compliant System
- (ISA) 13 Numeric data processor
- (PCI) 11 Intel(R) ICH9 Family SMBus Controller - 2930
- (PCI) 16 Intel(R) 82574L Gigabit Network Connection #2
- (PCI) 16 Intel(R) ICH9 Family PCI Express Root Port 1 - 2940
- (PCI) 16 Intel(R) ICH9 Family PCI Express Root Port 5 - 2948
- (PCI) 16 Intel(R) ICH9 Family USB Universal Host Controller - 2937
- (PCI) 16 Mobile Intel(R) 4 Series Express Chipset Family
- (PCI) 17 Intel(R) 82574L Gigabit Network Connection
- (PCI) 17 Intel(R) ICH9 Family PCI Express Root Port 6 - 294A
- (PCI) 18 Intel(R) ICH9 Family USB Universal Host Controller - 2936
- (PCI) 18 Intel(R) ICH9 Family USB2 Enhanced Host Controller - 293C
- (PCI) 19 Intel(R) ICH9 Family USB Universal Host Controller - 2939
- (PCI) 19 Intel(R) ICH9 Family USB Universal Host Controller - 2935
- (PCI) 19 Intel(R) ICH9M/M-E 2 port Serial ATA Storage Controller 1 - 2928
- (PCI) 19 Intel(R) ICH9M/M-E 2 port Serial ATA Storage Controller 2 - 292D
- (PCI) 21 Intel(R) ICH9 Family USB Universal Host Controller - 2938
- (PCI) 21 VIA VT6421 RAID Controller
- (PCI) 22 Microsoft UAA Bus Driver for High Definition Audio
- (PCI) 23 Intel(R) ICH9 Family USB Universal Host Controller - 2934
- (PCI) 23 Intel(R) ICH9 Family USB2 Enhanced Host Controller - 293A

C.3 <Input /Output (IO)>

[00000000 - 0000000F]	Direct memory access controller
[00000000 - 00000CF7]	PCI bus
[00000010 - 0000001F]	Motherboard resources
[00000020 - 00000021]	Programmable interrupt controller
[00000022 - 0000003F]	Motherboard resources
[00000040 - 00000043]	System timer
[00000044 - 0000005F]	Motherboard resources
[00000060 - 00000060]	Standard 101/102-Key or Microsoft Natural PS/2 Keyboard
[00000061 - 00000061]	System speaker
[00000062 - 00000063]	Motherboard resources
[00000064 - 00000064]	Standard 101/102-Key or Microsoft Natural PS/2 Keyboard
[00000065 - 0000006F]	Motherboard resources
[00000070 - 00000073]	System CMOS/real time clock
[00000074 - 0000007F]	Motherboard resources
[00000080 - 00000090]	Direct memory access controller
[00000091 - 00000093]	Motherboard resources
[00000094 - 0000009F]	Direct memory access controller
[000000A0 - 000000A1]	Programmable interrupt controller
[000000A2 - 000000BF]	Motherboard resources
[000000C0 - 000000DF]	Direct memory access controller
[000000E0 - 000000EF]	Motherboard resources
[000000F0 - 000000FF]	Numeric data processor
[00000274 - 00000277]	ISAPNP Read Data Port
[00000279 - 00000279]	ISAPNP Read Data Port
[000002F8 - 000002FF]	Communications Port (COM2)
[00000378 - 0000037F]	Printer Port (LPT1)
[000003B0 - 000003BB]	Mobile Intel(R) 4 Series Express Chipset Family
[000003C0 - 000003DF]	Mobile Intel(R) 4 Series Express Chipset Family
[000003F0 - 000003F5]	Standard floppy disk controller
[000003F7 - 000003F7]	Standard floppy disk controller
[000003F8 - 000003FF]	Communications Port (COM1)
[00000400 - 000004BF]	Motherboard resources
[000004D0 - 000004D1]	Motherboard resources
[00000500 - 0000051F]	Intel(R) ICH9 Family SMBus Controller - 2930

[00000680 - 000006FF]	Motherboard resources
[00000778 - 0000077B]	Printer Port (LPT1)
[00000880 - 0000088F]	Motherboard resources
[00000A79 - 00000A79]	ISAPNP Read Data Port
[00000D00 - 0000FFFF]	PCI bus
[00005000 - 00005FFF]	Intel(R) ICH9 Family PCI Express Root Port 1 - 2940
[00006000 - 00006FFF]	PCI standard PCI-to-PCI bridge
[00007800 - 000078FF]	VIA VT6421 RAID Controller
[00007C00 - 00007C1F]	VIA VT6421 RAID Controller
[00008000 - 0000800F]	VIA VT6421 RAID Controller
[00008400 - 0000840F]	VIA VT6421 RAID Controller
[00008800 - 0000880F]	VIA VT6421 RAID Controller
[00008C00 - 00008C0F]	VIA VT6421 RAID Controller
[00009000 - 00009FFF]	Intel(R) ICH9 Family PCI Express Root Port 6 - 294A
[00009C00 - 00009C1F]	Intel(R) 82574L Gigabit Network Connection
[0000A000 - 0000AFFF]	Intel(R) ICH9 Family PCI Express Root Port 5 - 2948
[0000AC00 - 0000AC1F]	Intel(R) 82574L Gigabit Network Connection #2
[0000B000 - 0000B00F]	Intel(R) ICH9M/M-E 2 port Serial ATA Storage Controller 2 - 292D
[0000B400 - 0000B40F]	Intel(R) ICH9M/M-E 2 port Serial ATA Storage Controller 2 - 292D
[0000B800 - 0000B803]	Intel(R) ICH9M/M-E 2 port Serial ATA Storage Controller 2 - 292D
[0000BC00 - 0000BC07]	Intel(R) ICH9M/M-E 2 port Serial ATA Storage Controller 2 - 292D
[0000C000 - 0000C003]	Intel(R) ICH9M/M-E 2 port Serial ATA Storage Controller 2 - 292D
[0000C400 - 0000C407]	Intel(R) ICH9M/M-E 2 port Serial ATA Storage Controller 2 - 292D
[0000CC00 - 0000CC0F]	Intel(R) ICH9M/M-E 2 port Serial ATA Storage Controller 1 - 2928
[0000D000 - 0000D00F]	Intel(R) ICH9M/M-E 2 port Serial ATA Storage Controller 1 - 2928
[0000D400 - 0000D403]	Intel(R) ICH9M/M-E 2 port Serial ATA Storage Controller 1 - 2928
[0000D800 - 0000D807]	Intel(R) ICH9M/M-E 2 port Serial ATA Storage Controller 1 - 2928
[0000DC00 - 0000DC03]	Intel(R) ICH9M/M-E 2 port Serial ATA Storage Controller 1 - 2928
[0000E000 - 0000E007]	Intel(R) ICH9M/M-E 2 port Serial ATA Storage Controller 1 - 2928
[0000E400 - 0000E41F]	Intel(R) ICH9 Family USB Universal Host Controller - 2936
[0000E800 - 0000E81F]	Intel(R) ICH9 Family USB Universal Host Controller - 2935
[0000EC00 - 0000EC1F]	Intel(R) ICH9 Family USB Universal Host Controller - 2934
[0000F000 - 0000F01F]	Intel(R) ICH9 Family USB Universal Host Controller - 2939
[0000F400 - 0000F41F]	Intel(R) ICH9 Family USB Universal Host Controller - 2938
[0000F800 - 0000F81F]	Intel(R) ICH9 Family USB Universal Host Controller - 2937
[0000FC00 - 0000FC07]	Mobile Intel(R) 4 Series Express Chipset Family

C.4 <Memory Address Map>

[00000000 - 0009FFFF]	System board
[000A0000 - 000BFFFF]	Mobile Intel(R) 4 Series Express Chipset Family
[000A0000 - 000BFFFF]	PCI bus
[000C0000 - 000DFFFF]	PCI bus
[000E0000 - 000EFFFF]	System board
[000F0000 - 000FFFFFF]	System board
[00100000 - 7BC8FFFF]	System board
[7BC90000 - 7BCFFFFFF]	System board
[7BD00000 - 7BDFFFFFF]	System board
[7BD00000 - FEBFFFFFF]	PCI bus
[D0000000 - DFFFFFFF]	Mobile Intel(R) 4 Series Express Chipset Family
[E0000000 - EFFFFFFF]	Motherboard resources
[FD000000 - FD3FFFFFF]	Mobile Intel(R) 4 Series Express Chipset Family
[FD600000 - FD6FFFFFF]	Intel(R) ICH9 Family PCI Express Root Port 1 - 2940
[FD700000 - FD7FFFFFF]	PCI standard PCI-to-PCI bridge
[FD800000 - FD8FFFFFF]	PCI standard PCI-to-PCI bridge
[FDA00000 - FDAFFFFFF]	Intel(R) ICH9 Family PCI Express Root Port 6 - 294A
[FDB00000 - FDBFFFFFF]	Intel(R) ICH9 Family PCI Express Root Port 6 - 294A
[FDBC0000 - FDBDFFFF]	Intel(R) 82574L Gigabit Network Connection
[FDBFC000 - FDBFFFFFF]	Intel(R) 82574L Gigabit Network Connection
[FDC00000 - FDCFFFFFF]	Intel(R) ICH9 Family PCI Express Root Port 5 - 2948
[FDD00000 - FDDFFFFFF]	Intel(R) ICH9 Family PCI Express Root Port 5 - 2948
[FDDC0000 - FDDDFFFF]	Intel(R) 82574L Gigabit Network Connection #2
[FDDFC000 - FDDFFFFFF]	Intel(R) 82574L Gigabit Network Connection #2
[FDE00000 - FDEFFFFFF]	Intel(R) ICH9 Family PCI Express Root Port 1 - 2940
[FDFF4000 - FDFF7FFF]	Microsoft UAA Bus Driver for High Definition Audio
[FDFFD000 - FDFFD0FF]	Intel(R) ICH9 Family SMBus Controller - 2930
[FDFFE000 - FDFFE3FF]	Intel(R) ICH9 Family USB2 Enhanced Host Controller - 293A
[FDFFF000 - FDFFF3FF]	Intel(R) ICH9 Family USB2 Enhanced Host Controller - 293C
[FEB00000 - FEBFFFFFF]	Mobile Intel(R) 4 Series Express Chipset Family
[FEC00000 - FEC00FFF]	System board
[FED00000 - FED000FF]	System board

Appendix D <Programming GPIO's>

The GPIO's can be programmed with the MSDOS debug program using simple IN/ OUT commands. The following lines show an example how to do this.

GPIO0.....GPIO7 bit0.....bit7

-o 2E 87

-o 2E 87 ;Enter configuration

-o 2E 07

-o 2F 09 ;Enable GPIO's function

-o 2E 30

-o 2F 02 ;Enable GPIO's configuration

-o 2E F0

-o 2F xx ;Set GPIO's as input/output; set '1' for input,'0'for output

-o 2E F1

-o 2F xx ;If set GPIO's as output, in this register its value can be set

Optional:

-o 2E F2

-o 2F xx ; Data inversion register; '1' inverts the current value of the bits,'0' leaves them as they are

-o 2E 30

-o 2F 01 ; Active GPIO's

For further information, please refer to Winbond W83627DHG datasheet.

Appendix E <Programming Watchdog Timer>

The watchdog timer makes the system auto-reset while it stops to work for a period.

The integrated watchdog timer can be setup as system reset mode by program.

Time-out Value Range

- 1 to 255

- Second or Minute

Program Sample

Watchdog timer setup as system reset with 5 second of timeout

2E, 87	
2E, 87	
2E, 07	
2F, 08	Logical Device 8
2E, 30	
2F, 01	Activate
2E, F5	
2F, 00	Set as Second*
2E, F6	
2F, 05	Set as 5

* Minute: bit 3 = 1; Second: bit 3 = 0

You can select Timer setting in the BIOS, after setting the time options, the system will reset according to the period of your selection.