

OWNER'S MANUAL

KOHLER COURAGE SV710-740

KOHLER COURAGE PRO SV810-840

VERTICAL CRANKSHAFT



KOHLER
ENGINES

Safety Precautions

To ensure safe operation please read the following statements and understand their meaning. Also refer to your equipment owner's manual for other important safety information. This manual contains safety precautions which are explained below. Please read carefully.

WARNING

Warning is used to indicate the presence of a hazard that *can* cause *severe* personal injury, death, or substantial property damage if the warning is ignored.

CAUTION



Caution is used to indicate the presence of a hazard that *will* or *can* cause *minor* personal injury or property damage if the caution is ignored.

NOTE

Note is used to notify people of installation, operation, or maintenance information that is important but not hazard-related.



For Your Safety!

These precautions should be followed at all times. Failure to follow these precautions could result in injury to yourself and others.

 WARNING

Explosive Fuel can cause fires and severe burns.
Do not fill the fuel tank while the engine is hot or running.



Explosive Fuel!

Gasoline is extremely flammable and its vapors can explode if ignited. Store gasoline only in approved containers, in well ventilated, unoccupied buildings, away from sparks or flames. Do not fill the fuel tank while the engine is hot or running, since spilled fuel could ignite if it comes in contact with hot parts or sparks from ignition. Do not start the engine near spilled fuel. Never use gasoline as a cleaning agent.

 WARNING

Rotating Parts can cause severe injury.
Stay away while engine is in operation.



Rotating Parts!

Keep hands, feet, hair, and clothing away from all moving parts to prevent injury. Never operate the engine with covers, shrouds, or guards removed.

 WARNING

Hot Parts can cause severe burns.
Do not touch engine while operating or just after stopping.

Hot Parts!

Engine components can get extremely hot from operation. To prevent severe burns, do not touch these areas while the engine is running, or immediately after it is turned off. Never operate the engine with heat shields or guards removed.

 CAUTION

Electrical Shock can cause injury.
Do not touch wires while engine is running.

Electrical Shock!

Never touch electrical wires or components while the engine is running. They can be sources of electrical shock.

California Proposition 65 Warning
<i>Engine exhaust from this product contains chemicals known to the State of California to cause cancer, birth defects, or other reproductive harm.</i>



Safety Precautions (Cont.)

 WARNING

Accidental Starts can cause severe injury or death. Disconnect and ground spark plug leads before servicing.



Accidental Starts!

Disabling engine. Accidental starting can cause severe injury or death. Before working on the engine or equipment, disable the engine as follows: 1) Disconnect the spark plug lead(s). 2) Disconnect negative (-) battery cable from battery.

 WARNING

Carbon Monoxide can cause severe nausea, fainting or death. Avoid inhaling exhaust fumes, and never run the engine in a closed building or confined area.

Lethal Exhaust Gases!

Engine exhaust gases contain poisonous carbon monoxide. Carbon monoxide is odorless, colorless, and can cause death if inhaled. Avoid inhaling exhaust fumes, and never run the engine in a closed building or confined area.

 WARNING

Explosive Gas can cause fires and severe acid burns. Charge battery only in a well ventilated area. Keep sources of ignition away.

Explosive Gas!

Batteries produce explosive hydrogen gas while being charged. To prevent a fire or explosion, charge batteries only in well ventilated areas. Keep sparks, open flames, and other sources of ignition away from the battery at all times. Keep batteries out of the reach of children. Remove all jewelry when servicing batteries.

Before disconnecting the negative (-) ground cable, make sure all switches are OFF. If ON, a spark will occur at the ground cable terminal which could cause an explosion if hydrogen gas or gasoline vapors are present.

Congratulations – You have selected a fine four-cycle, twin cylinder, air-cooled engine. Kohler designs long life strength and on-the-job durability into each engine...making a Kohler engine dependable...dependability you can count on. Here are some reasons why:

- Efficient overhead valve design, and pressure lubrication provide maximum power, torque, and reliability under all operating conditions.
- Dependable, maintenance-free electronic ignition ensures fast, easy starts time after time.
- Kohler engines are easy to service. All routine service areas (like the dipstick and oil fill, air cleaner, spark plugs, and carburetor) are easily and quickly accessible.
- Parts subject to the most wear and tear (like the cylinder liner and camshaft) are made from precision formulated cast iron.
- Every Kohler engine is backed by a worldwide network of over 10,000 distributors and dealers. Service support is just a phone call away. Call 1-800-544-2444 (U.S. & Canada) for Sales & Service assistance.

To keep your engine in top operating condition, follow the maintenance procedures in this manual.

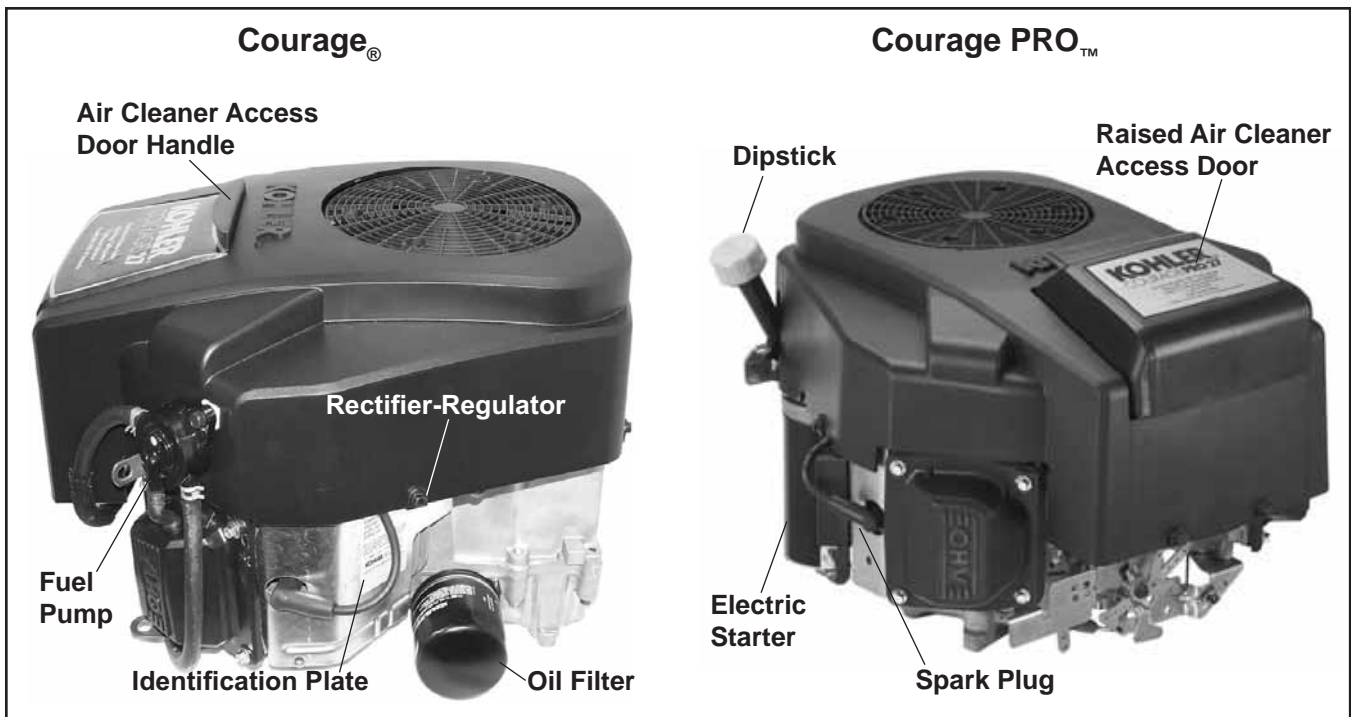

Figure 1. Typical Courage® and Courage PRO™ Series Vertical Shaft Engines.

Oil Recommendations

Using the proper type and weight of oil in the crankcase is extremely important. So is checking oil daily and changing oil regularly. Failure to use the correct oil, or using dirty oil, causes premature engine wear and failure.

Oil Type

Use high quality detergent oil of API (American Petroleum Institute) service class SG, SH, SJ or higher. Select the viscosity based on the air temperature at the time of operation as shown in the following table.

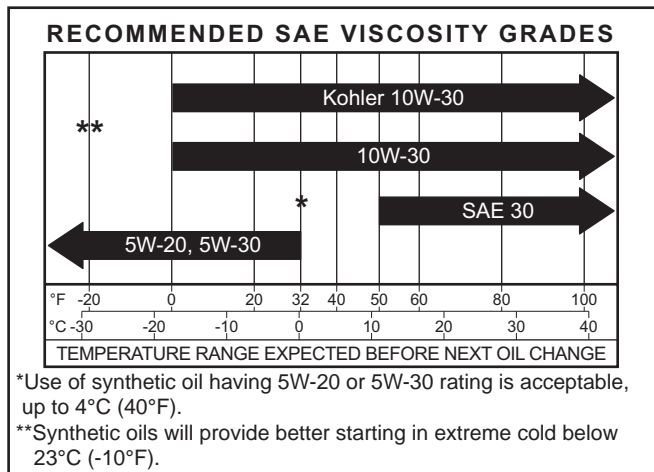

Figure 2. Viscosity Grades Table.

NOTE: Using other than service class SG, SH, SJ or higher oil or extending oil change intervals longer than recommended can cause engine damage.

NOTE: Synthetic oils meeting the listed classifications may be used with oil changes performed at the recommended intervals. However to allow piston rings to properly seat, a new or rebuilt engine should be operated for at least 50 hours using standard petroleum based oil before switching to synthetic oil.

A logo or symbol on oil containers identifies the API service class and SAE viscosity grade. See Figure 3.



Figure 3. Oil Container Logo.

Refer to Maintenance Instructions beginning on page 7 for detailed oil check, oil change, and oil filter change procedures.

Fuel Recommendations

⚠ WARNING: Explosive Fuel!

Gasoline is extremely flammable and its vapors can explode if ignited. Store gasoline only in approved containers, in well ventilated, unoccupied buildings, away from sparks or flames. Do not fill the fuel tank while the engine is hot or running, since spilled fuel could ignite if it comes in contact with hot parts or sparks from ignition. Do not start the engine near spilled fuel. Never use gasoline as a cleaning agent.

General Recommendations

Purchase gasoline in small quantities and store in clean, approved containers. A container with a capacity of 2 gallons or less with a pouring spout is recommended. Such a container is easier to handle and helps eliminate spillage during refueling.

Do not use gasoline left over from the previous season, to minimize gum deposits in your fuel system and to ensure easy starting.

Do not add oil to the gasoline.

Do not overfill the fuel tank. Leave room for the fuel to expand.

Fuel Type

For best results use only clean, fresh, unleaded gasoline with the pump sticker octane rating of 87 or higher. In countries using the Research method, it should be 90 octane minimum.

Unleaded gasoline is recommended as it leaves less combustion chamber deposits and reduces harmful exhaust emissions. Leaded gasoline is not recommended.

Gasoline/Alcohol blends

Gasohol (up to 10% ethyl alcohol, 90% unleaded gasoline by volume) is approved as a fuel for Kohler engines. Other gasoline/alcohol blends including E20 and E85 are not to be used and not approved. Any failures resulting from use of these fuels will not be warranted.

Gasoline/Ether blends

Methyl Tertiary Butyl Ether (MTBE) and unleaded gasoline blends (up to a maximum of 15% MTBE by volume) are approved as a fuel for Kohler engine. Other gasoline/ether blends are not approved.

Engine Identification Numbers

When ordering parts, or in any communication involving an engine, always give the **Model, Specification, and Serial Numbers** of the engine.

The engine identification numbers appear on a decal (or decals) affixed to the engine shrouding. Include letter suffixes, if there are any.

Record your engine identification numbers on the identification label (Figure 4) for future reference.

KOHLER[®]

IMPORTANT ENGINE INFORMATION
 THIS ENGINE MEETS U.S. EPA PH2 AND EC STAGE II (SN:4) EMISSION REGS FOR SI SORE. NOT FOR SALE IN CALIFORNIA UNLESS PREEMPT PER SEC. 209 (e) (1) OF CAA.

FAMILY

TYPE APP
DISPL. (CC)
MODEL NO.
SPEC. NO.
SERIAL NO.
BUILD DATE
OEM PROD. NO.

 N11236

EMISSION COMPLIANCE PERIOD:
 EPA: CARB:
 CERTIFIED ON:
 REFER TO OWNER'S MANUAL FOR HP RATING, SAFETY, MAINTENANCE AND ADJUSTMENTS
 1-800-544-2444 KohlerEngines.com
 KOHLER CO. KOHLER, WISCONSIN USA

KOHLER[®]

IMPORTANT ENGINE INFORMATION
 THIS ENGINE MEETS U.S. EPA PH2 AND CA 2008 AND LATER EXH EMISSION REGS FOR SI SORE. USING DELEGATED ASSEMBLY FOR AFTERTREATMENT.

FAMILY

TYPE APP
DISPL. (CC)
MODEL NO.
SPEC. NO.
SERIAL NO.
BUILD DATE
OEM PROD. NO.

 N11236

EMISSION COMPLIANCE PERIOD:
 EPA: CARB:
 CERTIFIED ON:
 REFER TO OWNER'S MANUAL FOR HP RATING, SAFETY, MAINTENANCE AND ADJUSTMENTS
 1-800-544-2444 KohlerEngines.com
 KOHLER CO. KOHLER, WISCONSIN USA

Figure 4. Engine Identification Label.

The Emission Compliance Period referred to on the Emission Control or Air Index label indicates the number of operating hours for which the engine has been shown to meet Federal and CARB emission requirements. The following table provides the Engine Compliance Period (in hours) associated with the category descriptor found on the certification label.

Emission Compliance Period (Hours)

EPA	Category C 250 hours	Category B 500 hours	Category A 1000 hours
CARB	Moderate 125 hours	Intermediate 250 hours	Extended 500 hours

Refer to certification label for engine displacement.

Exhaust Emission Control System for models SV710-SV840 is EM for U.S. EPA and Europe; PAIR for California Tier III.

Operating Instructions

Also read the operating instructions of the equipment this engine powers.

Pre-Start Checklist

- Check oil level. Add oil if low. Do not overfill.
- Check fuel level. Add fuel if low.
- Check cooling air intake areas and external surfaces of engine. Make sure they are clean and unobstructed.
- Check that the air cleaner components and all shrouds, equipment covers, and guards are in place and securely fastened.
- Check that any clutches or transmissions are disengaged or placed in neutral. This is especially important on equipment with hydrostatic drive. The shift lever must be exactly in neutral to prevent resistance which could keep the engine from starting.



WARNING: Lethal Exhaust Gases!

Engine exhaust gases contain poisonous carbon monoxide. Carbon monoxide is odorless, colorless, and can cause death if inhaled. Avoid inhaling exhaust fumes, and never run the engine in a closed building or confined area.

Cold Weather Starting Hints

1. Be sure to use the proper oil for the temperature expected. See Figure 2 on page 4.
2. Declutch all possible external loads.
3. Be sure the battery is in good condition. A warm battery has much more starting capacity than a cold battery.
4. Use fresh winter grade fuel. NOTE: Winter grade gasoline has higher volatility to improve starting. Do not use gasoline left over from summer.

Starting

1. Place the throttle control **midway** between the **slow** and **fast** positions. Place the choke control into the **on** position.
2. Start the engine by activating the key switch. Release the switch as soon as the engine starts.

NOTE: Do not crank the engine continuously for more than 10 seconds at a time. If the engine does not start, allow a 60 second cool down period between starting attempts. Failure to follow these guidelines can burn out the starter motor.

NOTE: If the engine develops sufficient speed to disengage the starter but does not keep running (a false start), engine rotation must be allowed to come to a complete stop before attempting to restart the engine.

If the starter is engaged while the flywheel is rotating, the starter pinion and flywheel ring gear may clash, resulting in damage to the starter.

If the starter does not turn the engine over, shut off starter immediately. Do not make further attempts to start the engine until the condition is corrected. Do not jump start using another battery (refer to Battery). See your Kohler Engine Service Dealer for service assistance.

3. **For a Cold Engine** – Gradually return the choke control to the **off** position after the engine starts and warms up.

The engine/equipment may be operated during the warm-up period, but it may be necessary to leave the choke partially on until the engine warms up.

4. **For a Warm Engine** – Return choke to **off** position as soon as engine starts.

Stopping

1. Remove the load by disengaging all PTO driven attachments.
2. **For Engines without a Shutdown Solenoid:** Move the throttle to the **slow** or **low** idle position. Allow the engine to run at idle for 30-60 seconds; then stop the engine.

For Engines Equipped with a Shutdown Solenoid: Position the throttle control between half and full throttle; then stop the engine.

Battery

A 12 volt battery is normally used. Refer to the operating instructions of the equipment this engine powers for specific battery requirements.

If the battery charge is not sufficient to crank the engine, recharge the battery.

Operating

Angle of Operation

This engine will operate continuously at angles up to 25°. Check oil level to assure crankcase oil level is at the **FULL** or “F” mark on the dipstick.

Refer to the operating instructions of the equipment this engine powers. Because of equipment design or application, there may be more stringent restrictions regarding the angle of operation.

NOTE: Do not operate this engine continuously at angles exceeding 25° in any direction. Engine damage could result from insufficient lubrication.

Cooling

NOTE: If debris builds up on the grass screen or other cooling areas, stop the engine immediately and clean. Operating the engine with blocked or dirty air intake and cooling areas can cause extensive damage due to overheating. See Clean Air Intake/Cooling Area.

Maintenance Instructions

Maintenance, repair, or replacement of the emission control devices and systems, which are being done at the customers expense, may be performed by any non-road engine repair establishment or individual. Warranty repairs must be performed by an authorized Kohler service outlet.



WARNING: Accidental Starts!

Disabling engine. Accidental starting can cause severe injury or death. Before working on the engine or equipment, disable the engine as follows: 1) Disconnect the spark plug lead(s). 2) Disconnect negative (-) battery cable from battery.

Maintenance Schedule

These required maintenance procedures should be performed at the frequency stated in the table. They should also be included as part of any seasonal tune-up.

Frequency	Maintenance Required
Daily Or Before Starting Engine	<ul style="list-style-type: none"> • Fill fuel tank. • Check oil level. • Check air cleaner for dirty¹, loose, or damaged parts. • Check air intake and cooling areas, clean as necessary¹.
Every 25 Hours	<ul style="list-style-type: none"> • Service precleaner element¹.
Every 50 Hours	<ul style="list-style-type: none"> • Check air cleaner element, clean or replace as necessary¹.
Annually or Every 100 Hours	<ul style="list-style-type: none"> • Replace air cleaner element and precleaner¹. • Change oil and oil filter (more frequently under severe conditions). • Remove cooling shrouds and clean cooling areas¹. • Replace fuel filter. • Check spark plug condition and gap.
Every 300 Hours	<ul style="list-style-type: none"> • Have valve lash checked/adjusted².
Every 500 Hours	<ul style="list-style-type: none"> • Have bendix starter drive serviced². • Have solenoid shift starter disassembled and cleaned².

¹Perform these maintenance procedures more frequently under extremely dusty, dirty conditions.

²Have a Kohler Engine Service Dealer perform these services.

Check Oil Level

The importance of checking and maintaining the proper oil level in the crankcase cannot be overemphasized. Check oil **BEFORE EACH USE** as follows:



WARNING: Hot Parts!

Engine components can get extremely hot from operation. To prevent severe burns, do not touch these areas while the engine is running, or immediately after it is turned off. Never operate the engine with heat shields or guards removed.

Engine Speed

NOTE: Do not tamper with the governor setting to increase the maximum engine speed. Overspeed is hazardous and will void the engine warranty. The maximum allowable high idle speed for these engines is 3675 RPM, no load.

1. Make sure the engine is stopped, level, and is cool so the oil has had time to drain into the sump.
2. Clean the area around and the underside of the oil fill cap/dipstick before removing it. This will help keep dirt, debris, and other foreign matter out of the engine.

3. Remove the oil fill cap/dipstick; wipe oil off.

For engines with a press-on style dipstick:

Reinsert the dipstick into the tube and press all the way down. See Figure 5.

For engines with a thread-on style dipstick:

Reinsert the dipstick into the oil fill tube and thread the dipstick in completely. See Figures 5 and 6.

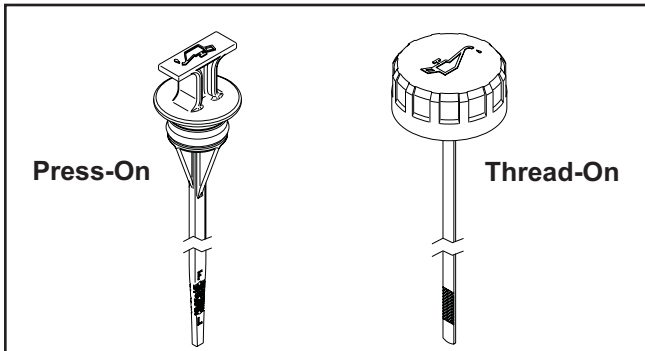

Figure 5. Dipstick Styles.

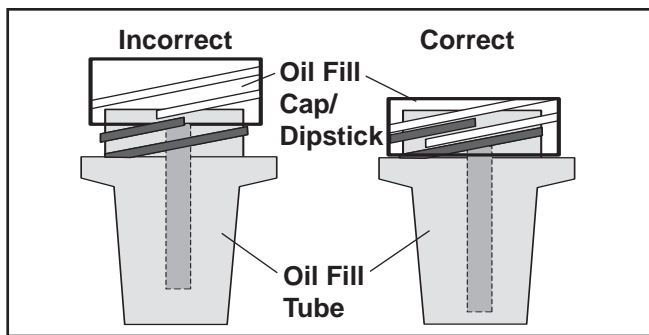

Figure 6. Thread-on Oil Fill Cap/Dipstick.

4. Remove the oil fill cap/dipstick and check oil level. The oil level needs to be within the operating range. See Figure 7. If low, add oil of the proper type, up to the full mark. If oil is above the "F" or FULL mark, drain oil to reach proper level. Reinstall the oil fill cap/dipstick.

NOTE: To prevent extensive engine wear or damage, always maintain the proper oil level in the crankcase. Never operate the engine with the oil level above the "F" or FULL mark, or below the "L" or LOW mark on the dipstick.

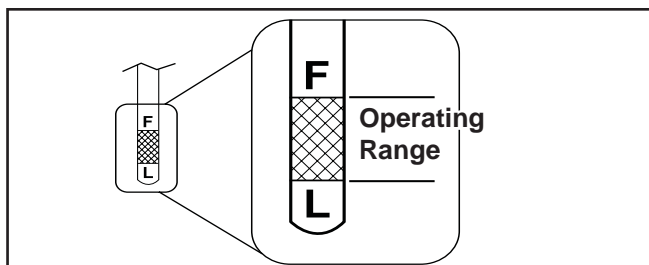

Figure 7. Oil Level Marks on Dipstick (Typical).

Oil Sentry™

Some engines are equipped with an optional Oil Sentry™ oil pressure switch. If the oil pressure drops below an acceptable level, the Oil Sentry™ will either shut off the engine or activate a warning signal, depending on the application.

NOTE: Make sure the oil level is checked **BEFORE EACH USE** and is maintained up to the **FULL** or "F" mark on the dipstick. This includes engines equipped with Oil Sentry™.

Change Oil and Oil Filter

Change the oil and oil filter **annually** or every **100 hours** of operation (more frequently under severe conditions). Refill with service class SG, SH, SJ, or higher oil as specified in the Viscosity Grades table (Figure 2) on page 4. Always use a genuine Kohler oil filter. Use chart below to determine part number to order.

Oil Filter Part No.	Length
12 050 01-S	2-1/2"
52 050 02-S	3-3/8"

Change the oil while the engine is still warm. The oil will flow more freely and carry away more impurities. Make sure the engine is level when filling, checking, or changing the oil.

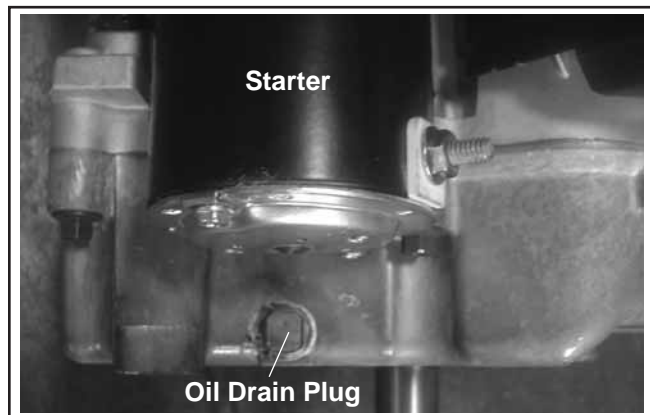

Figure 8. Oil Drain Plug.



Figure 9. Oil Filter Location.

Change the oil and oil filter as follows.

1. The drain plug is located on the starter side of the oil pan. See Figure 8. Clean the area around the oil drain plug and the oil fill cap/dipstick.
2. Remove the drain plug and the oil fill cap/dipstick.
3. Allow the oil to drain and then reinstall the drain plug. Tighten **13.6 N·m (10 ft. lb.)**.
4. Remove the old filter and wipe off the filter adapter with a clean cloth.
5. Place a new replacement filter in a shallow pan with the open end up. Pour new oil, of the proper type, in through the threaded center hole. Stop pouring when the oil reaches the bottom of the threads. Allow a minute or two for the oil to be absorbed by the filter material.
6. Apply a thin film of clean oil to the rubber gasket on the new oil filter.
7. Install the new oil filter to the filter adapter. Hand tighten the filter until the rubber gasket contacts the adapter, then tighten the filter an additional **3/4-1 turn**.
8. Fill the engine with the proper oil to the **FULL** or **"F"** mark on the dipstick. Always check the oil level with the dipstick before adding more oil.
9. Reinstall the oil fill cap/dipstick and tighten securely.
10. Start the engine and check for oil leaks. Recheck oil level before placing the engine into service. Stop the engine, correct any leaks, and allow a minute for the oil to drain down, then recheck the level on the dipstick.

NOTE: To prevent extensive engine wear or damage, always maintain the proper oil level in the crankcase. Never operate the engine with the oil level above the **"F"** or **FULL** mark, or below the **"L"** or **LOW** mark or on the dipstick.

Service Precleaner and Air Cleaner Element

These engines are equipped with a replaceable, high density paper air cleaner element. Some engines are also equipped with an oiled, foam precleaner which surrounds the paper element. See Figures 10 and 11. Two different capacity air cleaner systems are available.

Check the air cleaner **daily or before starting the engine**. Check for a buildup of dirt and debris around the air cleaner system. Keep this area clean. Also check for loose or damaged components. Replace all bent or damaged air cleaner components.

NOTE: Operating the engine with loose or damaged air cleaner components could allow unfiltered air into the engine causing premature wear and failure.

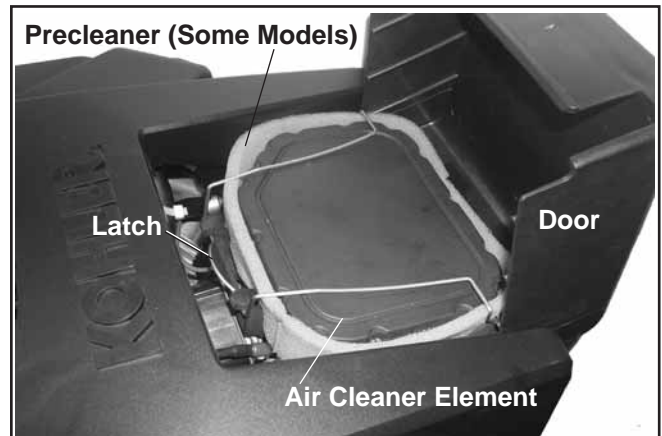

Figure 10. Courage Air Cleaner System.

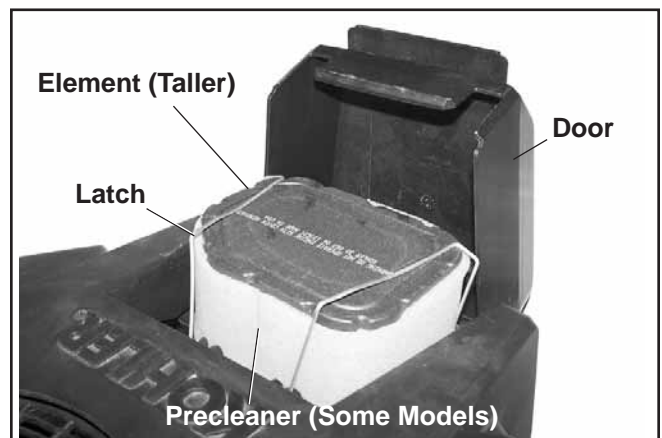

Figure 11. Courage PRO Air Cleaner System.

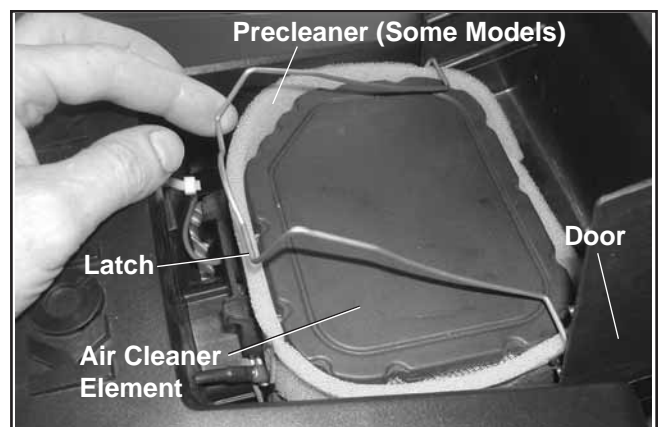

Figure 12. Unhooking Latch (Courage).

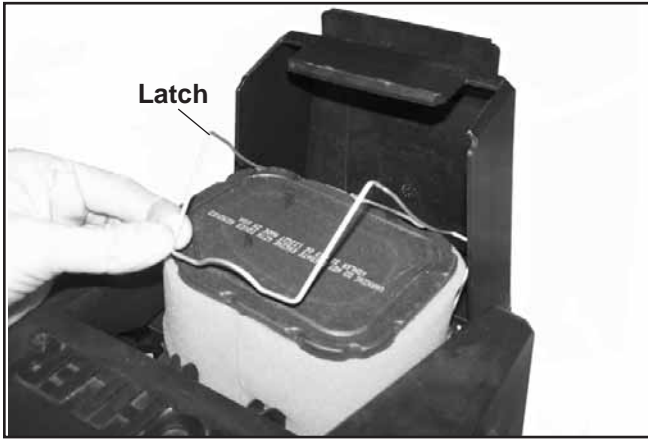

Figure 13. Unhooking Latch (Courage PRO).

Service Precleaner

If so equipped, wash and reoil the precleaner every **25 hours** of operation (more often under extremely dusty or dirty conditions). Replace the precleaner **annually** or every **100 hours**.

1. Open the door on the blower housing to access the air cleaner element and precleaner. See Figures 10 and 11.
2. Unhook the latch and remove the precleaner from the air cleaner element, or remove as an assembly for servicing. Make sure the base and the sealing area is clean before reassembly is performed. See Figures 12 and 13.
3. Wash the precleaner in warm water with detergent. Rinse the precleaner thoroughly until all traces of detergent are eliminated. Squeeze out excess water (do not wring). Allow the precleaner to air dry.
4. Saturate the precleaner with new engine oil. Squeeze out all excess oil.
5. Reinstall the precleaner over the paper element and secure with the latch.
6. Close and latch the door.
7. When precleaner replacement is necessary order genuine Kohler Parts.

32 083 05-S Precleaner	37 mm (1.45 in.) high
32 083 08-S Precleaner (PRO)	71 mm (2.79 in.) high

Service Paper Element

Check the paper element every **50 hours** of operation, (more often under extremely dusty or dirty conditions). Clean or replace the element as necessary. Replace the air cleaner element **annually**, or every **100 hours**.

1. Open the door on the blower housing to access the air cleaner element. See Figures 9 and 10.
2. Unhook the latch and remove the air cleaner element and precleaner (if equipped). See Figure 12 and 13.
3. Remove the precleaner (if so equipped) from the paper element. Service the precleaner as described in Precleaner Service.
4. Gently tap the paper element to dislodge dirt. **Do not wash the paper element or use pressurized air**, as this will damage the element. Replace a dirty, bent, or damaged element with a genuine Kohler part. Handle the new element carefully; do not use if the sealing surfaces are bent or damaged.

32 083 03-S Element	44 mm (1.73 in.) high
32 083 06-S Element (PRO)	78 mm (3.07 in.) high

5. Clean the air cleaner base as required and check condition.
6. Reinstall the precleaner (if equipped) over the paper air cleaner element and install on the base. Secure with the latch.
7. Close and latch the door.

Clean Air Intake/Cooling Areas

To ensure proper cooling, make sure the grass screen, cooling fins, and other external surfaces of the engine are kept clean at all times.

Every **100 hours** of operation (more often under extremely dusty, dirty conditions), remove the blower housing and other cooling shrouds. Clean the cooling fins and external surfaces as necessary. Make sure the cooling shrouds are reinstalled.

NOTE: Operating the engine with a blocked grass screen, dirty or plugged cooling fins, and/or cooling shrouds removed, will cause engine damage due to overheating.

Ignition System

These engines use an electronic Capacitive Discharge (CD) ignition system. Other than periodically checking/replacing the spark plugs, no maintenance, timing, or adjustments are necessary or possible with this system.

Check Spark Plugs

Every 100 hours of operation, remove the spark plugs, check condition, and reset the gap or replace with new plugs as necessary. The standard Courage spark plug is a Champion® RC12YC (Kohler Part No. 12 132 02-S). RFI compliant engines use a Champion® XC12YC (Kohler Part No. 25 132 14-S) spark plug. A high-performance spark plug, Champion® Platinum 3071 (Kohler Part No. 25 132 12-S) is standard on Courage PRO models. Equivalent alternate brand plugs can also be used.

1. Before removing the spark plug, clean the area around the base of the plug to keep dirt and debris out of the engine.
2. Remove the plug and check its condition. Replace the plug if worn or reuse is questionable.

NOTE: Do not clean the spark plug in a machine using abrasive grit. Some grit could remain in the spark plug and enter the engine causing extensive wear and damage.

3. Check the gap using a wire feeler gauge. Adjust the gap to **0.76 mm (0.030 in.)** by carefully bending the ground electrode. See Figure 14.
4. Reinstall the spark plug into the cylinder head. Torque the spark plug to **24.4-29.8 N·m (18-22 ft. lb.)**.

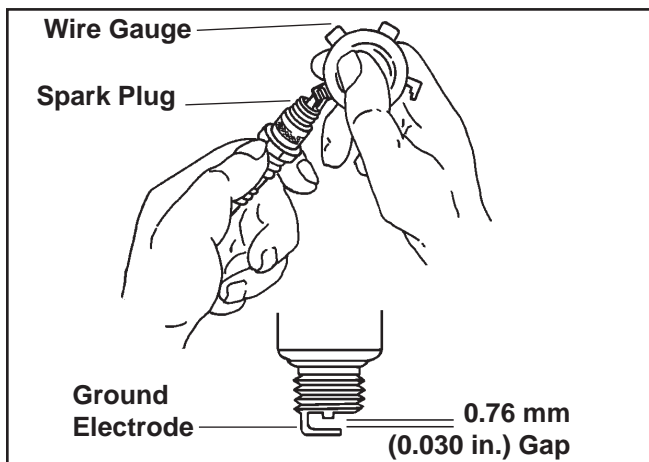

Figure 14. Servicing Spark Plug.

Battery Charging



WARNING: Explosive Gas!

Batteries produce explosive hydrogen gas while being charged. To prevent a fire or explosion, charge batteries only in well ventilated areas. Keep sparks, open flames, and other sources of ignition away from the battery at all times. Keep batteries out of the reach of children. Remove all jewelry when servicing batteries.

Before disconnecting the negative (-) ground cable, make sure all switches are OFF. If ON, a spark will occur at the ground cable terminal which could cause an explosion if hydrogen gas or gasoline vapors are present.

Fuel System

Fuel Filter

Some engines are equipped with an in-line fuel filter. Periodically inspect the filter and replace with a genuine Kohler filter every **100 operating hours**.

Fuel Line

In compliance with CARB Tier III Emission Regulations, these engines use Low Permeation SAE 30 R7 rated fuel line; certified to meet CARB requirements. Standard fuel line may not be used. Order replacement hose by part number through a Kohler Engine Service Dealer.



Figure 15. Low Permeation Fuel Line.

Carburetor Troubleshooting and Adjustments

In compliance with government emission standards, the carburetor is calibrated to deliver the correct fuel-to-air mixture to the engine under all operating conditions. The high speed mixture is set at the factory and cannot be adjusted. The low idle fuel adjustment screw (if equipped) is also set at the factory and normally does not require adjustment. See Figure 16. Engines in this series depending on the model and application, may also be equipped with a Governed Idle System.

If the engine is equipped with a Governed Idle System, refer to **Models with Governed Idle System** when performing any carburetor adjustment, as an additional step to the listed procedure(s) is required.

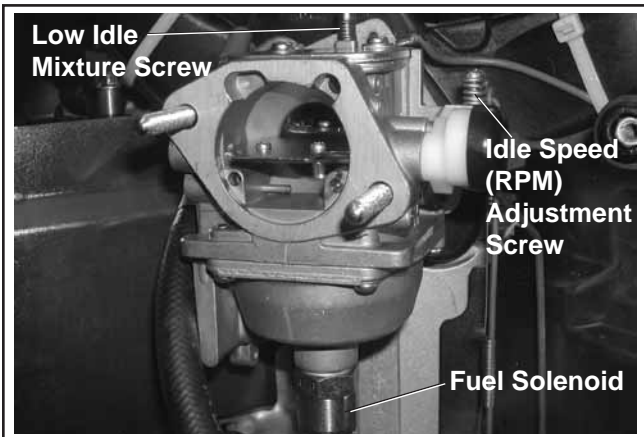

Figure 16. Carburetor Details.

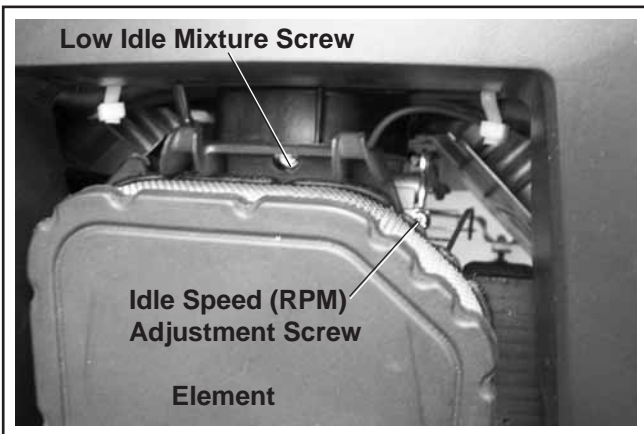

Figure 17. Carburetor Adjustment Access Locations (Latch Removed For Clarity).

Troubleshooting

If engine troubles are experienced that appear to be fuel system related, check the following areas before adjusting the carburetor.

- Make sure the fuel tank is filled with clean, fresh gasoline.
- Make sure the fuel tank cap vent is not blocked and that it is operating properly.
- If the fuel tank is equipped with a shut-off valve, make sure it is open.
- If the engine is equipped with an in-line fuel filter, make sure it is clean and unobstructed. Replace the filter if necessary.
- Make sure fuel is reaching the carburetor. This includes checking the fuel lines and fuel pump for restrictions or faulty components, replace as necessary.
- Make sure the air cleaner element is clean and all air cleaner element components are fastened securely.

If, after checking the items listed above, the engine is hard to start, runs roughly, or stalls at low idle speed, it may be necessary to adjust or service the carburetor.

Adjust Carburetor

NOTE: Some engines may have a fixed (capped) idle fuel adjusting screw or limiter cap. On these engines, do not attempt steps 1 and 2 below. Proceed directly to Step 3. On limiter equipped models, adjustment can only be performed within the limits allowed by the cap.

1. **Idle Fuel Adjustment:** with the engine stopped, turn the low idle fuel adjusting screw in (clockwise) until it bottoms lightly. See Figures 16 and 17.

NOTE: The tip of the low idle fuel adjusting screw is tapered to critical dimensions. Damage to the needle tip and the seat in carburetor body will result if the needle is forced.

2. **Preliminary Settings:** Turn the adjusting screw **out (counterclockwise)** from lightly bottomed 2-1/4 turns.
3. Start the engine and run at half throttle for 5 to 10 minutes to warm up. The engine must be warm before making final settings (step 4).
4. **Low Idle Speed (RPM) Setting:** Place the throttle control into the **idle** or **slow** position. Set the low idle speed to 1200 RPM* (± 75 RPM) by turning the low idle speed adjusting screw in or out. Check the speed using a tachometer.

*NOTE: The actual low idle speed depends on the application – refer to equipment manufacturer's recommendations. The recommended low idle speed for basic engines is 1200 RPM. To ensure best results when setting the low idle fuel needle, the low idle speed must not exceed 1200 RPM (± 75 RPM).

5. If proper operation is not restored after adjusting, carburetor servicing by an authorized Kohler Engine Service Dealer may be required.

Models with Governed Idle System

An optional governed idle control system is supplied on some engines. The purpose of this system is to maintain a desired idle speed regardless of ambient conditions (temperature, parasitic load, etc.) that may change. Engines with this feature contain a small secondary spring connected between the governor lever and the lower adjustment tab of the main bracket. See Figure 18.

The system requires an additional procedure for setting the idle speed. If speed adjustments are required proceed as follows.

1. Make any necessary speed or control adjustments following the appropriate instructions covered in this section.
2. Move the throttle control to the idle position. Hold the governor lever away from the carburetor, or hold the throttle lever so it is tight against the idle speed adjusting screw, to negate the governor activation. See Figure 19. Check the speed with a tachometer and adjust it to 1500 RPM.
3. Release the governor lever and allow the engine to return to the governed idle speed. Check it with a tachometer against the equipment manufacturers recommended idle speed. Governed Idle Speed (RPM) is typically 300 RPM (approximate) higher than the low idle speed. If adjustment is necessary, bend the adjusting tab on the speed control assembly to set. See Figure 18.

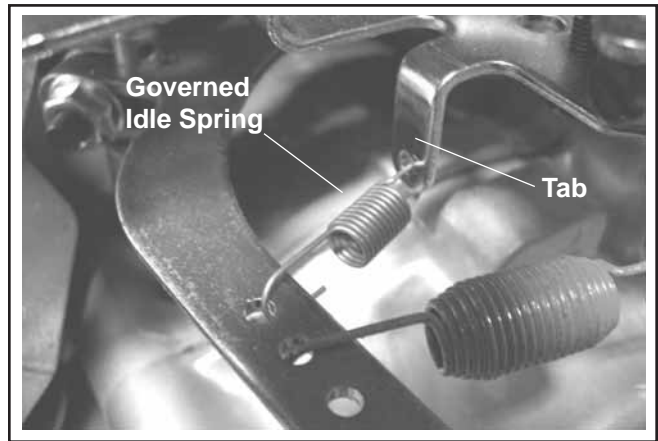

Figure 18. Governed Idle Spring Location.



Figure 19. Holding Throttle Lever Against Idle Stop Screw.

Troubleshooting

When troubles occur, be sure to check the simple causes which, at first, may seem too obvious to be considered. For example, a starting problem could be caused by an empty fuel tank. Some common causes of engine troubles are listed in the following table.

Do not attempt to service or replace major engine components, or any items that require special timing or adjustment procedures. Have your Kohler Engine Service Dealer do this work.

Possible Cause Problem	No Fuel	Improper Fuel	Dirt In Fuel Line /System	Dirty Grass Screen	Incorrect Oil Level	Engine Overloaded	Dirty Air Cleaner	Faulty Spark Plug
Will Not Start	•	•	•		•	•	•	•
Hard Starting		•	•			•	•	•
Stops Suddenly	•		•	•	•	•	•	•
Lacks Power		•	•	•	•	•	•	•
Operates Erratically		•	•	•		•	•	•
Knocks or Pings		•		•		•		•
Skips or Misfires		•	•	•			•	•
Backfires		•	•			•	•	•
Overheats		•	•	•	•	•	•	
High Fuel Consumption						•	•	•

Storage

If the engine will be out of service for two months or more, use the following storage procedure:

1. Clean the exterior surfaces of the engine.

2. Change the oil and filter while the engine is still warm from operation. See Change Oil and Oil Filter on page 8.

- The fuel system must be completely emptied, or the gasoline must be treated with a stabilizer to prevent deterioration. If you choose to use a stabilizer, follow the manufacturer's recommendations, and add the correct amount for the capacity of the fuel system. Fill the fuel tank with clean, fresh gasoline. Run the engine for 2-3 minutes to get stabilized fuel into the carburetor. Close fuel shut off valve when unit is being stored or transported.

To empty the system, run the engine until the tank and system are empty.

- Remove the spark plugs. Add one tablespoon of engine oil into each spark plug hole. Install plugs, but do not connect the plug leads. Crank the engine two or three revolutions.
- Store the engine in a clean, dry place.

Parts Ordering

The engine Specification, Model, and Serial Numbers are required when ordering replacement parts from your Kohler Engine Service Dealer. These numbers are found on the identification plate which is affixed to the engine shrouding. Include letter suffixes if there are any. See Engine Identification Numbers on page 5.

Always insist on genuine Kohler parts. All genuine Kohler parts meet strict standards for fit, reliability, and performance.

Major Repair

Major repair information is available in Kohler Engine Service Manuals. This type of repair generally requires the services of a trained mechanic and the use of special tools and equipment. Kohler Engine Service Dealers have the facilities, training, and genuine Kohler replacement parts necessary to perform this service.

For the nearest Sales & Service location:

- visit our website www.kohlerengines.com
- call 1-800-544-2444 (U.S. & Canada)
- look in the yellow pages under Engines-Gasoline

Model Designation

Model SV730 for example: S designates Courage engine, V designates vertical crankshaft, and 730 indicates the numerical model designation. A letter suffix designates a specific version as follows:

Suffix	Designates
S	Electric Start

Courage® SV710-740 Specifications

Model:	SV710	SV715	SV720
Bore:	83 (3.27)	83 (3.27)	83 (3.27)
Stroke:	67 (2.64)	67 (2.64)	67 (2.64)
Displacement:	725 (44.2)	725 (44.2)	725 (44.2)
Power (@ 3600 RPM):	14.9 (20*)	16.4 (22*)	17.2 (23*)
Compression Ratio:	9:1	9:1	9:1
Weight:	41.2 (91)	41.2 (91)	41.2 (91)
Oil Capacity (w/filter) - approximate, determined by oil filter used:	1.6-1.8 L (1.7-1.9 U.S. qt.)		
Lubrication:	Combination Pressure/Splash Lube w/full Flow Filter		

Model:	SV725/SV730	SV735	SV740
Bore:	83 (3.27)	83 (3.27)	83 (3.27)
Stroke:	67 (2.64)	67 (2.64)	67 (2.64)
Displacement:	725 (44.2)	725 (44.2)	725 (44.2)
Power (@ 3600 RPM):	17.9(24*)/18.6 (25*)	19.3 (26*)	20.1(27*)
Compression Ratio:	9:1	9:1	9:1
Weight:	41.2 (91)	41.2 (91)	41.2 (91)
Oil Capacity (w/filter) - approximate, determined by oil filter used:	1.6-1.8 L (1.7-1.9 U.S. qt.)		
Lubrication:	Combination Pressure/Splash Lube w/full Flow Filter		

Exhaust Emission Control System for models SV710-SV740 is EM for U.S. EPA and Europe; PAIR for California Tier III.

*Horsepower ratings exceed Society of Automotive Engineers Small Engine Test Code J1940. Actual engine horsepower is lower and affected by, but not limited to, accessories (air cleaner, exhaust, charging, cooling, fuel pump, etc.), application, engine speed and ambient operating conditions (temperature, humidity, and altitude). Kohler reserves the right to change product specifications, design, and standard equipment without notice and without incurring obligation.

COURAGE® SV710-740 ENGINE LIMITED WARRANTY

Kohler Co. warrants to the original retail consumer that each new COURAGE® engine sold by Kohler Co. will be free from manufacturing defects in materials or workmanship in normal residential homeowner service for a period of two (2) years from date of purchase, provided it is operated and maintained in accordance with Kohler Co.'s instructions and manuals. If used commercially the COURAGE® engine is covered by a 90 day* limited warranty.

The warranty period begins on the date of purchase by the original retail consumer or commercial end user. "Residential homeowner service" means residential use by a retail consumer. "Commercial use" means all other uses, including use for commercial, or rental purposes. Once in commercial use, the engine will thereafter be considered a commercial use engine for the purposes of this warranty.

Our obligation under this warranty is expressly limited, at our option, to the replacement or repair at Kohler Co., Kohler, Wisconsin 53044, or at a service facility designated by us of such parts as inspection shall disclose to have been defective.

EXCLUSIONS:

Mufflers on engines used commercially (non-residential) are warranted for 90 days from date of purchase.

This warranty does not apply to defects caused by casualty or unreasonable use, including faulty repairs by others and failure to provide reasonable and necessary maintenance.

The following items are not covered by this warranty:

Engine accessories such as fuel tanks, clutches, transmissions, power-drive assemblies, and batteries, unless supplied or installed by Kohler Co. These are subject to the warranties, if any, of their manufacturers.

KOHLER CO. AND/OR THE SELLER SHALL NOT BE LIABLE FOR SPECIAL, INDIRECT, INCIDENTAL, OR CONSEQUENTIAL DAMAGES OF ANY KIND, including but not limited to labor costs or transportation charges in connection with the repair or replacement of defective parts.

IMPLIED OR STATUTORY WARRANTIES, INCLUDING WARRANTIES OF MERCHANTABILITY OR FITNESS FOR A PARTICULAR PURPOSE, ARE EXPRESSLY LIMITED TO THE DURATION OF THIS WRITTEN WARRANTY. We make no other express warranty, nor is any one authorized to make any on our behalf.

Some states do not allow limitations on how long an implied warranty lasts, or the exclusion or limitation of incidental or consequential damages, so the above limitation or exclusion may not apply to you.

This warranty gives you specific legal rights, and you may also have other rights which vary from state to state.

TO OBTAIN WARRANTY SERVICE:

Purchaser must bring the engine to an authorized Kohler service facility. To locate the nearest facility, visit our website, www.kohlerengines.com, and click on DEALER LOCATOR to use the locator function, consult your Yellow Pages or telephone 1-800-544-2444.

ENGINE DIVISION, KOHLER CO., KOHLER, WISCONSIN 53044

*With the exception of countries governed by the European Union (EU), where a one (1) year warranty is required for commercial/professional use.

Courage PRO™ SV810-840 Specifications

Model:	SV810.....	SV820
Bore:	mm (in.).....83 (3.27).....	83 (3.27)
Stroke:	mm (in.).....67 (2.64).....	67 (2.64)
Displacement:	cm ³ (in ³).....725 (44.2).....	725 (44.2)
Power (@ 3600 RPM):.....	kW (HP).....14.9 (20*).....	17.2 (23*)
Compression Ratio:.....	9:1.....	9:1
Weight:	kg (lb.).....41.2 (91).....	41.2 (91)
Oil Capacity (w/filter) - approximate, determined by oil filter used: -----	1.6-1.8 L (1.7-1.9 U.S. qt.) -----	
Lubrication: -----	Combination Pressure/Splash Lube w/full Flow Filter -----	

Model:	SV830.....	SV840
Bore:	mm (in.).....83 (3.27).....	83 (3.27)
Stroke:	mm (in.).....67 (2.64).....	67 (2.64)
Displacement:	cm ³ (in ³).....725 (44.2).....	725 (44.2)
Power (@ 3600 RPM):.....	kW (HP).....18.6 (25*).....	20.1(27*)
Compression Ratio:.....	9:1.....	9:1
Weight:	kg (lb.).....41.2 (91).....	41.2 (91)
Oil Capacity (w/filter) - approximate, determined by oil filter used: -----	1.6-1.8 L (1.7-1.9 U.S. qt.) -----	
Lubrication: -----	Combination Pressure/Splash Lube w/full Flow Filter -----	

Exhaust Emission Control System for models SV810-SV840 is EM for U.S. EPA and Europe; PAIR for California Tier III.

*Horsepower ratings exceed Society of Automotive Engineers Small Engine Test Code J1940. Actual engine horsepower is lower and affected by, but not limited to, accessories (air cleaner, exhaust, charging, cooling, fuel pump, etc.), application, engine speed and ambient operating conditions (temperature, humidity, and altitude). Kohler reserves the right to change product specifications, design, and standard equipment without notice and without incurring obligation.

COURAGE PROTM SV810-840 ENGINE LIMITED WARRANTY

Kohler Co. warrants to the original retail consumer that each new COURAGE PROTM engine sold by Kohler Co. will be free from manufacturing defects in materials or workmanship in normal residential homeowner service for a period of two (2) years from date of purchase, provided it is operated and maintained in accordance with Kohler Co.'s instructions and manuals. If used commercially the COURAGE PROTM engine is covered by a one (1) year limited warranty.

The warranty period begins on the date of purchase by the original retail consumer or commercial end user. "Residential homeowner service" means residential use by a retail consumer. "Commercial use" means all other uses, including use for commercial, or rental purposes. Once in commercial use, the engine will thereafter be considered a commercial use engine for the purposes of this warranty.

Our obligation under this warranty is expressly limited, at our option, to the replacement or repair at Kohler Co., Kohler, Wisconsin 53044, or at a service facility designated by us of such parts as inspection shall disclose to have been defective.

EXCLUSIONS:

Mufflers on engines used commercially (non-residential) are warranted for one (1) year from date of purchase.

This warranty does not apply to defects caused by casualty or unreasonable use, including faulty repairs by others and failure to provide reasonable and necessary maintenance.

The following items are not covered by this warranty:

Engine accessories such as fuel tanks, clutches, transmissions, power-drive assemblies, and batteries, unless supplied or installed by Kohler Co. These are subject to the warranties, if any, of their manufacturers.

KOHLER CO. AND/OR THE SELLER SHALL NOT BE LIABLE FOR SPECIAL, INDIRECT, INCIDENTAL, OR CONSEQUENTIAL DAMAGES OF ANY KIND, including but not limited to labor costs or transportation charges in connection with the repair or replacement of defective parts.

IMPLIED OR STATUTORY WARRANTIES, INCLUDING WARRANTIES OF MERCHANTABILITY OR FITNESS FOR A PARTICULAR PURPOSE, ARE EXPRESSLY LIMITED TO THE DURATION OF THIS WRITTEN WARRANTY. We make no other express warranty, nor is any one authorized to make any on our behalf.

Some states do not allow limitations on how long an implied warranty lasts, or the exclusion or limitation of incidental or consequential damages, so the above limitation or exclusion may not apply to you.

This warranty gives you specific legal rights, and you may also have other rights which vary from state to state.

TO OBTAIN WARRANTY SERVICE:

Purchaser must bring the engine to an authorized Kohler service facility. To locate the nearest facility, visit our website, www.kohlerengines.com, and click on DEALER LOCATOR to use the locator function, consult your Yellow Pages or telephone 1-800-544-2444.

ENGINE DIVISION, KOHLER CO., KOHLER, WISCONSIN 53044

KOHLER CO.
FEDERAL AND CALIFORNIA EMISSION CONTROL SYSTEMS
LIMITED WARRANTY
SMALL OFF-ROAD ENGINES

The U.S. Environmental Protection Agency (EPA), the California Air Resources Board (CARB), and Kohler Co. are pleased to explain the Federal and California Emission Control Systems Warranty on your small off-road equipment engine. In California beginning in 2006 "emissions" means both exhaust and evaporative emissions. For California, engines produced in 2006 and later must be designed, built and equipped to meet the state's stringent anti-smog standards. In other states, 1997 and later model year engines must be designed, built and equipped, to meet the U.S. EPA regulations for small non-road engines. The engine must be free from defects in materials and workmanship which cause it to fail to conform with U.S. EPA standards for the first two years of engine use from the date of sale to the ultimate purchaser. Kohler Co. must warrant the emission control system on the engine for the period of time listed above, provided there has been no abuse, neglect or improper maintenance.

The emission control system may include parts such as the carburetor or fuel injection system, the ignition system, and catalytic converter. Also included are the hoses, belts and connectors and other emission related assemblies.

Where a warrantable condition exists, Kohler Co. will repair the engine at no cost, including diagnosis (if the diagnostic work is performed at an authorized dealer), parts and labor.

MANUFACTURER'S WARRANTY COVERAGE

Engines produced in 2006 or later are warranted for two years in California. In other states, 1997 and later model year engines are warranted for two years. If any emission related part on the engine is defective, the part will be repaired or replaced by Kohler Co. free of charge.

OWNER'S WARRANTY RESPONSIBILITIES

- (a) The engine owner is responsible for the performance of the required maintenance listed in the owner's manual. Kohler Co. recommends that you retain all receipts covering maintenance on the engine, but Kohler Co. cannot deny warranty solely for the lack of receipts or for your failure to assure that all scheduled maintenance was performed.
- (b) Be aware, however, that Kohler Co. may deny warranty coverage if the engine or a part has failed due to abuse, neglect, improper maintenance or unapproved modifications.
- (c) For warranty repairs, the engine must be presented to a Kohler Co. service center as soon as a problem exists. Call 1-800-544-2444 or access our website at: www.kohlerengines.com, for the names of the nearest service centers. The warranty repairs should be completed in a reasonable amount of time, not to exceed 30 days.

If you have any questions regarding warranty rights and responsibilities, you should contact Kohler Co. at 1-920-457-4441 and ask for an Engine Service representative.

COVERAGE

Kohler Co. warrants to the ultimate purchaser and each subsequent purchaser that the engine will be designed, built and equipped, at the time of sale, to meet all applicable regulations. Kohler Co. also warrants to the initial purchaser and each subsequent purchaser, that the engine is free from defects in materials and workmanship which cause the engine to fail to conform with applicable regulations for a period of two years.

Engines produced in 2006 or later are warranted for two years in California. For 1997 and later model years, EPA requires manufacturers to warrant engines for two years in all other states. These warranty periods will begin on the date the engine is purchased by the initial purchaser. If any emission related part on the engine is defective, the part will be replaced by Kohler Co. at no cost to the owner. Kohler Co. is liable for damages to other engine components caused by the failure of a warranted part still under warranty.

Kohler Co. shall remedy warranty defects at any authorized Kohler Co. engine dealer or warranty station. Warranty repair work done at an authorized dealer or warranty station shall be free of charge to the owner if such work determines that a warranted part is defective.

Listed below are the parts covered by the Federal and California Emission Control Systems Warranty. Some parts listed below may require scheduled maintenance and are warranted up to the first scheduled replacement point for that part. The warranted parts include the following if they were present in the engine purchased:

- Oxygen sensor (if equipped)
- Intake manifold (if equipped)
- Exhaust manifold (if equipped)
- Catalytic muffler (if equipped)
- Thermal reactor muffler (if equipped)
- Ignition module(s) with high tension lead
- Gaseous fuel regulator (if equipped)
- Electronic control unit (if equipped)
- Carburetor or fuel injection system
- Fuel metering valve (if equipped)

Continued on next page.

- Fuel lines, fuel line fittings and clamps (if equipped)
- Spark advance module (if equipped)
- Crankcase breather
- Air Injection System (if equipped)
 - Air pump or pulse valve assembly (if equipped)
 - Control/distribution valve (if equipped)
 - Distribution manifold (if equipped)
 - Air hoses (if equipped)
 - Vacuum lines (if equipped)
- Air filter, fuel filter, and spark plugs (only to first scheduled replacement point)
- Evaporative System (if equipped)
 - Canister (if equipped)
 - Canister filter (if equipped)
 - Vapor hose (if equipped)
 - Orifice connector (if equipped)
 - Fuel tank (if equipped)
 - Fuel cap (if equipped)
 - Primer bulb canister (if equipped)

LIMITATIONS

This Emission Control Systems Warranty shall not cover any of the following:

- (a) repair or replacement required because of misuse or neglect, improper maintenance, repairs improperly performed or replacements not conforming to Kohler Co. specifications that adversely affect performance and/or durability and alterations or modifications not recommended or approved in writing by Kohler Co.,
- (b) replacement of parts and other services and adjustments necessary for required maintenance at and after the first scheduled replacement point,
- (c) consequential damages such as loss of time, inconvenience, loss of use of the engine or equipment, etc.,
- (d) diagnosis and inspection fees that do not result in eligible warranty service being performed, and
- (e) any add-on or modified part, or malfunction of authorized parts due to the use of add-on or modified parts.

MAINTENANCE AND REPAIR REQUIREMENTS

The owner is responsible for the proper use and maintenance of the engine. Kohler Co. recommends that all receipts and records covering the performance of regular maintenance be retained in case questions arise. If the engine is resold during the warranty period, the maintenance records should be transferred to each subsequent owner. Kohler Co. reserves the right to deny warranty coverage if the engine has not been properly maintained; however, Kohler Co. may not deny warranty repairs solely because of the lack of repair maintenance or failure to keep maintenance records.

Normal maintenance, replacement or repair of emission control devices and systems may be performed by any repair establishment or individual; however, **warranty repairs must be performed by a Kohler authorized service center**. Any replacement part or service that is equivalent in performance and durability may be used in non-warranty maintenance or repairs, and shall not reduce the warranty obligations of the engine manufacturer.

KOHLER[®] ENGINES

FOR SALES AND SERVICE INFORMATION
IN U.S. AND CANADA, CALL **1-800-544-2444**

KohlerEngines.com

ENGINE DIVISION, KOHLER CO., KOHLER, WISCONSIN 53044

FORM NO.:	32 590 01-B
ISSUED:	9/05
REVISED:	2/09

LITHO IN U.S.A.



1P32 590 01-B



6 50531 51365 6