

PAPCE



PORTABLE AIR POLLUTION CONTROL EQUIPMENT



User's Manual

Models PP-500 •
PP-500XP

U.S. Patents 6,143,048 6,264,711B1

Smith Eastern Corporation

10630-S Riggs Hill Road • Jessup, Maryland 20794-9425 USA
301.497.7600 • 800.937.HVLP (4857) • Fax 301.497.7613
papce@airverter.com • www.airverter.com

Compliance • Quality • Performance • Reliability

Please Read User's Manual *BEFORE*
Using This Equipment

**WHEN IN THE PROXIMITY OF HAZARDOUS FUGITIVE EMISSIONS
USE PROPER PERSONAL SAFETY EQUIPMENT INCLUDING
RESPIRATOR, GOGGLES AND SAFETY CLOTHING.**

WARNING

**THIS EQUIPMENT IS OPERATED WITH HIGH VOLTAGE ELECTRICITY.
ALWAYS TURN THE MACHINE "OFF" AND DISCONNECT POWER
PRIOR TO MAINTENANCE OR REPAIR.**

WARRANTY

Smith Eastern Corporation warrants to the Purchaser that Portable Air Pollution Control Equipment (PAPCE) is free from defects in material or workmanship under normal use and service for a period of twelve (12) months from the date of shipment.

Should any failure appear during this period, Smith Eastern shall, if given prompt written notice by the Purchaser, correct such nonconformity by repair or replacement of the nonconforming part, F.O.B. Smith Eastern's repair facility. Repair parts are warranted for ninety (90) days from the date of shipment, but repairs or replacements to original equipment shall not renew or extend the warranty period of such equipment.

Equipment and parts furnished by Smith Eastern but manufactured by others shall be limited to the warranty offered by the manufacturer thereof.

Smith Eastern reserves the right to limit this warranty in cases of misuse or abuse. Any modifications to equipment or recommended procedures will void the warranty.

The foregoing warranty is exclusive and in lieu of other warranties of quality or performance, expressed, implied or statutory, including any warranties of merchantability or of fitness for a particular purpose.

ABOUT PAPCE

PAPCE is a California South Coast Air Quality Management District (SCAQMD) approved portable suction-type control device to capture fugitive vapor, mist, gases, fumes, odors, and other liquid and solid particulate matter from spraying, sanding, grinding, and welding operations.

The adjustable filter arrangement allows maximum flexibility in the positioning of filters for optimum performance to suit a wide variety of applications. The articulating, self-supporting duct arms and tabletop downdraft containment system provide maximum flexibility in a portable particulate capture device.

Closing dampers in the twin Flexible Ducts directs all suction through the tabletop containment system. Additionally all energy can be directed through one duct for maximum suction over a smaller containment area. When the tabletop system is not in use all suction is directed through the Flexible Ducts.

UNCRATING, ARM INSTALLATION AND POWER SUPPLY VERIFICATION

Uncrate unit being careful not to damage the casters, duct support arms and collection Hood.

A. Verify all parts have been shipped and are not damaged

1. Ducts, Support Arms and Collection Hoods
2. Intake Filters (packaged in Table-top area)
3. Large Particulate Filter (Filter Compartment)
4. Pocket Filter (Filter Compartment)
5. HEPA Filter (Filter Compartment)
6. Carbon Filter (Filter Compartment)
7. Filter Frame

B. Verify unit is correctly wired for your power supply. Unless otherwise specified at time of order, PAPCEs are wired for 440v 3-phase.

C. Remove All Filters.

D. The unit is shipped without a cord-cap or plug. This is the responsibility of the receiving party. Consult a qualified electrician to determine the correct cord-cap for your facility. Have a qualified electrician install the cord-cap.

E. Plug in unit and switch on; verify motor turns clockwise when viewed from filter compartment. If motor does not turn clockwise wiring must be changed to conform to your power supply. Call 1-800-937-4857 if you need assistance.

F. Remove wrappings from filters and install according to Filter Installation instructions below.

G. Attach Support Arms and Ducts to the Swivel Mounts (see instructions on Attaching Swivel Mounts and Support Arms).

FILTER INSTALLATION

Filters should be installed as follows:

A. For most applications, including painting, an Intake Filter should be attached to each Intake Hood (attached using the Velcro dots installed on the Hood).

B. **For welding applications, do not use Intake Filters.** Intake Filters are made of polyester and could ignite.

C. Install filters in the filter compartment **left to right** as follows:

1. Carbon Filter (remove wrapping)
2. HEPA Filter
3. Pocket Filter
4. Large Particulate Filter (Pre-Filter) - The pre-filter should be installed with the less dense side of the filter to the right and the more dense side of the filter to the left.



Figure 1

ATTACHING SWIVEL MOUNTS AND SUPPORT ARMS

1. For shipping the Swivel Bases are each in their own cardboard box with the mounting bolts enclosed in a plastic bag.
2. Securely mount the Swivel Base and Gasket using the hardware provided. The Swivel Base consists of two parts that allow the upper section of the swivel to move separately from the lower section. The Swivel Base has a rubber-band-style boot. The boot is used to slip over the groove between the upper and lower sections so air will not be drawn from the groove. The swivel should rotate freely after the arm and duct are installed.
3. The metal support structure for the arm is folded for shipment. Carefully unfold the structure and ensure it moves freely. Put the arm back in its folded position, as it will be easier to mount to the Swivel Base. CAUTION: Do not get fingers caught between arm support tubes.
4. There are (2) bolts, nuts, & (6) washers on the arm's Base Plate. Remove these components. These bolts are not tightened on the Base Plate for easy removal.

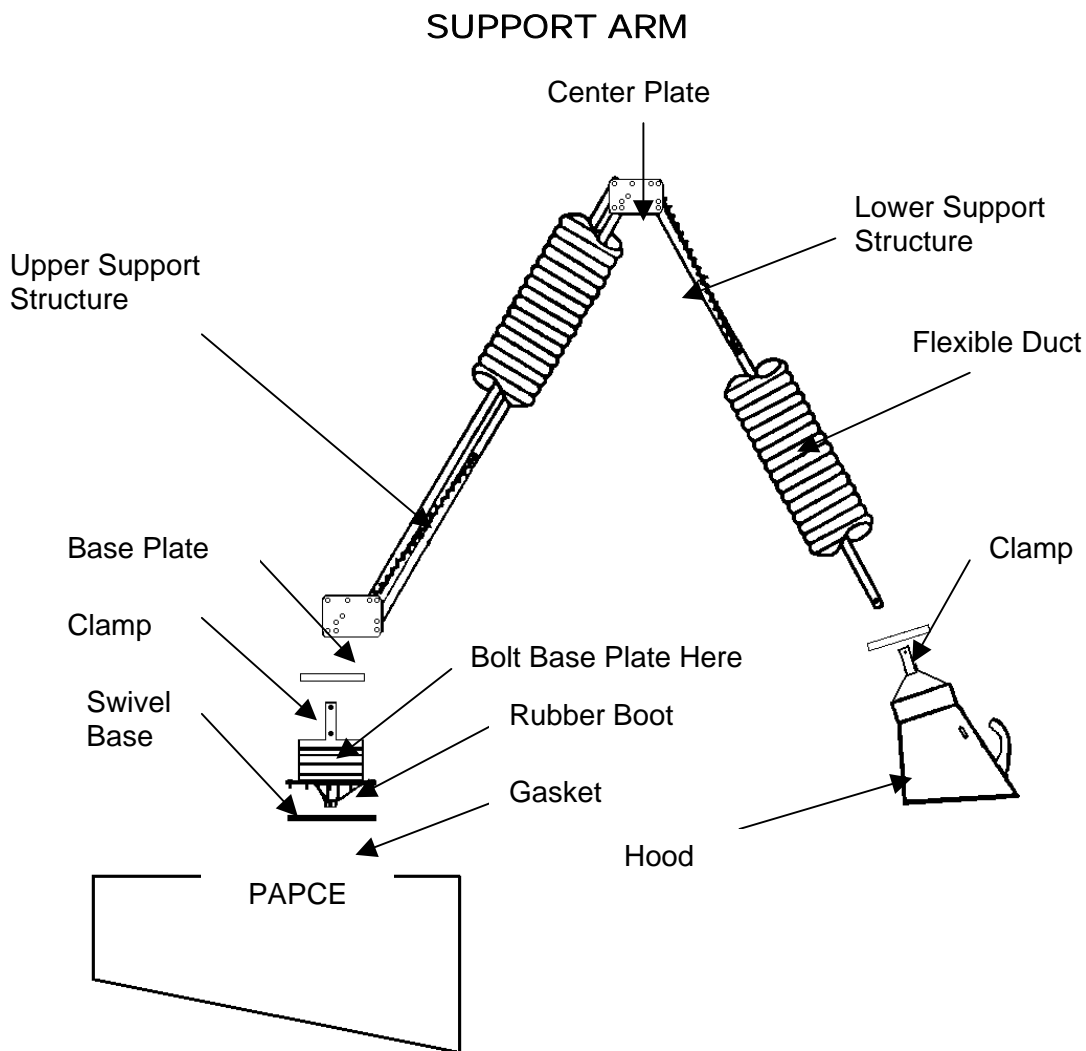

Figure 2

ATTACHING SWIVEL MOUNTS AND SUPPORT ARMS (continued)

- The Base Plate has multiple holes for many mounting configurations. You will use holes 1 & 8 for mounting the arm to the PAPCE. Bolt the Base Plate/arm to the swivel base using the hardware and holes 1 & 8. Tighten the hardware snugly.

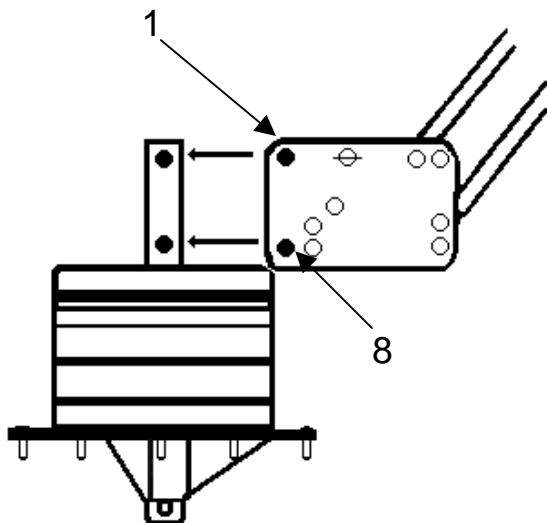

Figure 3

- Extend the arm out by pulling on the lower support structure. If the arm does not stay in place, slightly tighten the friction pivots located on the Base Plate and the Center Plate. These pivots use brown friction washers. There are (2) pivots located on the Base Plate and the Center Plate. Simply adjust the pivot points until the arm holds itself. Final pivot adjustment is to be done at the end of assembly.
- Slide the Flexible Duct over the arm and attach the duct to the swivel base by using the clamp provided. **DO NOT ALLOW THE FLEXIBLE DUCT TO GO OVER THE GROOVE OR THE RUBBER BOOT THAT COVERS THE GROOVE ON THE SWIVEL BASE.**
- Mount the Hood using the hardware supplied with the Hood. Please note how the hardware is positioned so the Hood will move easily and stay at that point. Your Hood has a built-in damper. Sometimes the damper blade can be loose and may tend to close

during use. Tighten the small screw on the damper lever so the damper will stay in its desired position, yet will move so the damper can be controlled.

- The Hood has (2) pivot joints so the Hood can be moved up, down, left, and right, independent of the arm. The hardware that mounted the Hood to the Hood arm bar should be adjusted so the Hood can move side to side and hold its position
- Final arm adjustment is based upon the arm holding itself in any position and not drifting. This will require the tightening or loosening of each of the pivot points located on the Base Plate, Center Plate, Hood arm bar, and Hood. The goal is to have the arm move as easily as possible and hold its position at the release point. The arm may need readjustment from time to time, dependent upon usage.
- DO NOT OVER TIGHTEN THE FRICTION PIVOT JOINTS AS DAMAGE CAN OCCUR TO THE FRICTION WASHERS. IT IS ALWAYS BETTER TO TIGHTEN THE JOINTS A LITTLE AT A TIME TO GAIN THE DESIRED MOVEMENT.**

OPERATION INTAKE HOODS

Position Intake Hood(s) in close proximity to work area (ideally within 12-18 inches) for source capturing and extraction of welding smoke, dust, paint overspray and hazardous airborne fumes.



Welding Fumes Extraction



Spraying Toward Filter Hoods

Certain applications may prevent the operator from positioning the intakes within 12-18 inches of the work (such as aircraft wheel wells). In these cases position the Hoods to create the best possible airflow.

Ensure dampers are fully opened for maximum efficiency.

The Intake Filters (PP-016) are flammable. **Remove the Intake Filters (PP-016) from Hood(s) before using for welding fume extraction.**

TABLETOP

When using the tabletop downdraft system, ensure the duct dampers are fully closed for maximum suction through the tabletop unit.

Position small parts so that the operator will be painting toward the tabletop.



Spraying On The Tabletop

FILTER EFFICIENCY

1. The Magnehelic Gauge allows the operator to monitor filter efficiency by measuring the pressure differential across the filters.
 - a. Readings of twice the amount recorded when filters are new indicate clogged filters. For instance, if the Magnehelic Gauge reads 2 when the filters are new, a reading of 4 would indicate the filters should be replaced for optimum performance.
 - b. The Magnehelic Gauge should be "zeroed" if required with zero adjustment screw in the front of the gauge (plastic cover should not be removed).
 - c. As the Intake Filters (PP-016) are outside the area measured by the Magnehelic Gauge, these filters should be changed frequently, depending on the volume of paint sprayed.

BLOWER OPERATION

1. The distance between the Blower and Inlet Cone is critical to effective and safe operation of the PAPCE unit. The unit is adjusted at the factory to the proper distance.
2. The user should periodically inspect the unit to ensure the Blower remains firmly attached to the Motor shaft and has not shifted its position on the shaft.

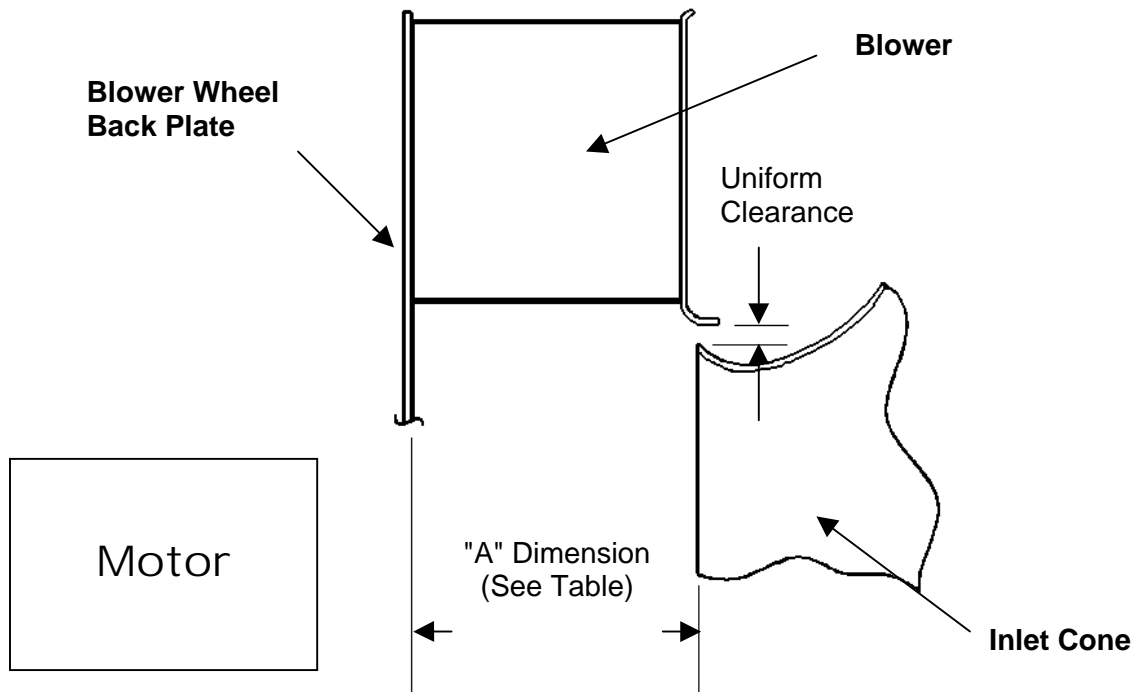

Wheel-to-Inlet Cone Clearances	
Blower Wheel Size	"A" Dimension
16	2.30 in.

ILLUSTRATED PARTS BREAKDOWN
SUPPORT ARM AND FLEXIBLE DUCT
(Models PP-500 and PP-500XP)

PP-025-10
10 Ft. X 7 In. Support Arm With
Flexible Duct and Hood

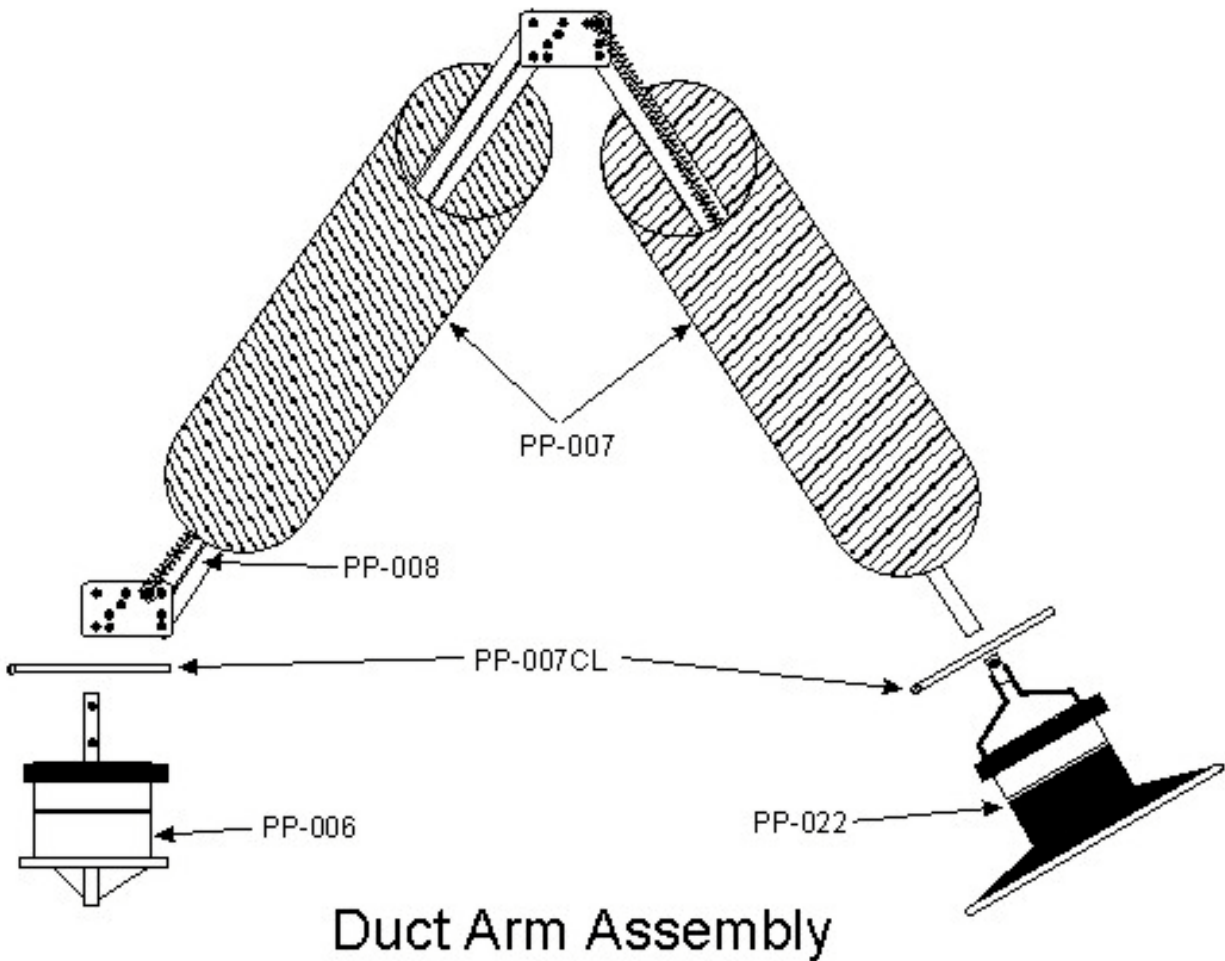

ILLUSTRATED PARTS BREAKDOWN PP-500

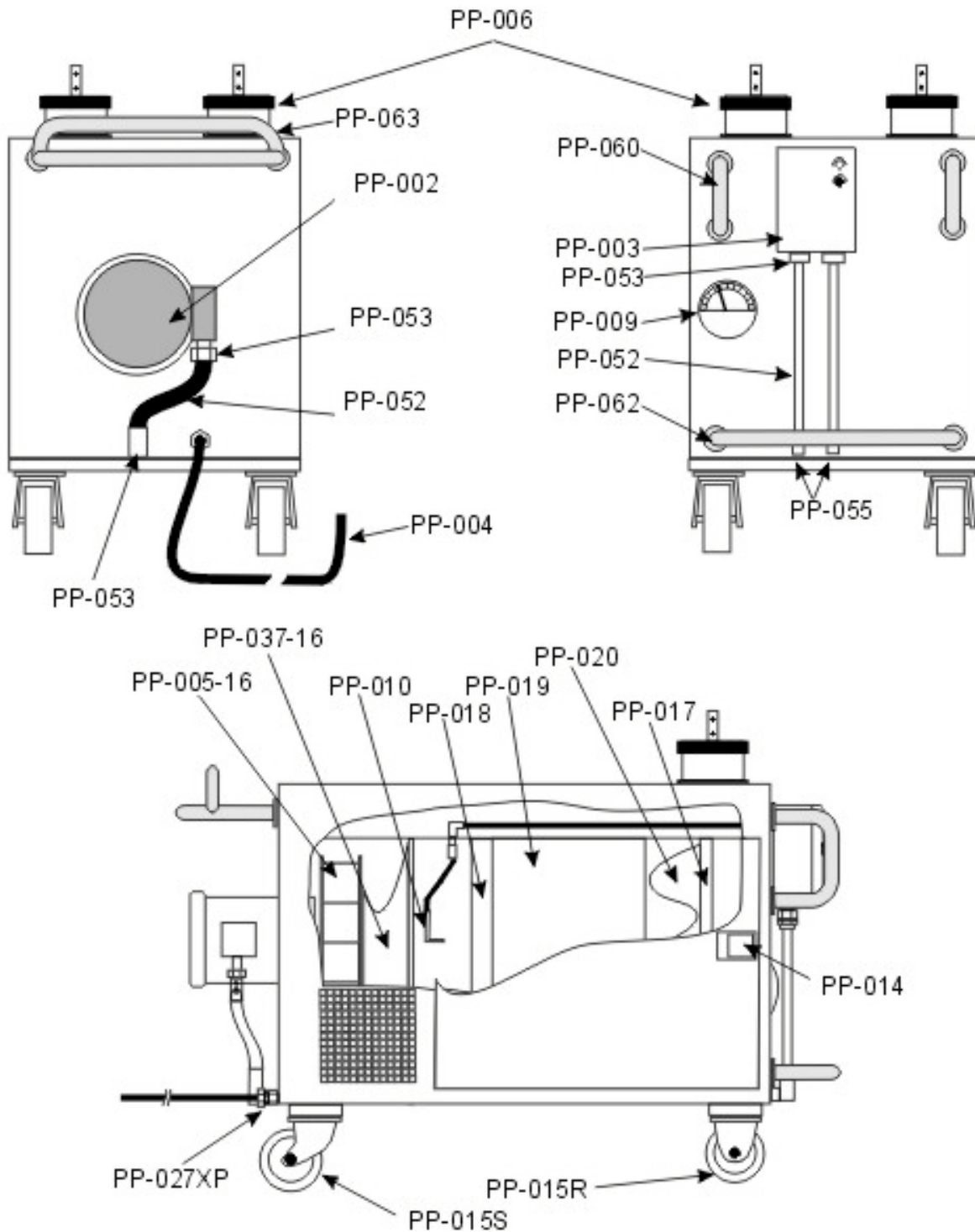

ILLUSTRATED PARTS BREAKDOWN PP-500XP

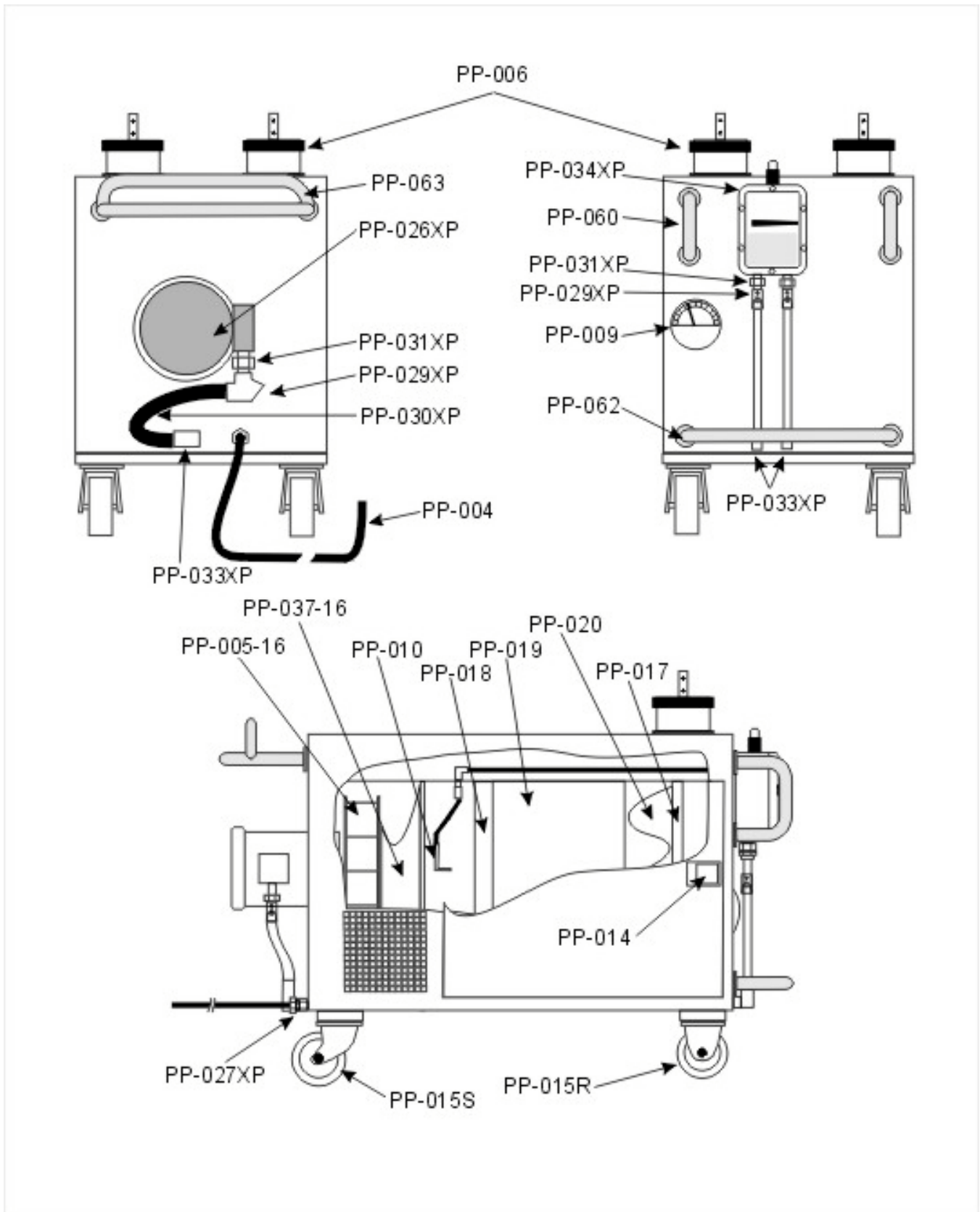

COMPONENTS

INTAKE AND LARGE PARTICULATE FILTERS (PRE-FILTERS)

The Large Particulate Filter media is 100% polyester. The dual-stage, layered media has a less dense layer on the air-entering side and a denser layer on the air-leaving side. This density pattern prevents face loading as larger particles are trapped in the front layer and smaller particles in the back layer.

Applications include:

1. Paint Overspray
2. Sanding Dust
3. Oil Mist
4. Adhesive Overspray

Construction and Performance Data	
Media Size	24" x 24" x 1"
Media	100% Polyester
Resistance @ 400 FPM	.20" W.G.
Paint Holding Capacity	2.7 lbs. Per Sq. Ft.

POCKET FILTERS

Construction: The Pocket Filters are made from two layers of 100% polyester fibers.

- The first layer of the dual-layer media is constructed of a blend of small denier fibers, tightly needled to achieve high efficiency. A heavy tack on the air leaving side holds particulates in the filter to prevent them from blowing downstream.
- The second layer is constructed of a saturated bond web utilizing a halogen-free binder system tightly needled to achieve high efficiency.
- Polyester media is moisture resistant. It is not affected by humidity - up to 100%, or sensible moisture. The pockets are

completely self-supporting in a V-shape configuration.

Self-Sealing Design: The pockets are sewn to 10-gauge wire internal support frames with the media extending beyond the frames to form a built-in gasket.

Long Service Life: The dual-layer media design in a multi-pocket configuration results in very high particulate holding capacity for long service life. The filters are ideal for difficult operating conditions, such as turbulent air flow or heavy dirt loading.

Construction and Performance Data	
Media Size	24" x 24" x 6"
Media	Dual Layer 100% Polyester
Resistance @ 400 FPM	.83" W.G.

HEPA FILTER

HEPA filters used in these units are designed for use where higher airflow velocities occur offering the user a wide range of advantages, including:

- Higher air flow with no increase in resistance.
- Higher velocities deliver up to 500 FPM while maintaining the highest efficiencies.

The filter has only .72" W.G. resistance at 1100 CFM, compared to 1.0" W.G. of standard HEPA filters. The filter has more media area in the

same amount of space, as do standard HEPA filters. This was accomplished through the use of a specially designed separator to allow up to 65% more media to be installed in a 24" x 24" x 11-1/2" area.

The result for the user is a filter that lasts longer and will operate at a higher capacity than typical HEPA filters.

Performance Data		
DIMENSIONS H x W x D	99.97% @ .3 Micron	
	CAPACITY (CFM) @ Initial Pressure Drop	
24 x 24 x 11-1/2	1.0"	1.35"
	1500	2000

ACTIVATED CARBON FILTER

Carbon Filters are designed for odor removal only. They are not for particulate collection. Odor removal is a direct function of the amount of carbon exposed to the air stream.

The Activated Carbon Filter has 1 1/3 pounds of carbon per square foot in a 2" thick pad (600 grams per sq. ft. of filter face area). Each filter is sealed to prevent adsorption from occurring prior to installation.

Carbon filters are designed for light to moderate odor conditions in multi-stage filtration systems where other filters are installed upstream from the carbon filters.

Other filters are necessary to remove particulate contaminants from the air to prevent coating the microscopic carbon pore structure.

Performance Data - 2" Filter	
<small>Based on ASHRAE Standard 52.1-1992. Tolerances conform to ARI Standard 850.84</small>	
Recommended Final Resistance	1.2" W.G.
Activity Rating	Minimum 60% on carbon tetrachloride at 251C.
UL Classification	UL Class 2 According to UL Standard 900
Recommended Temperature Limit	120 F (491 C).

DYWER MAGNEHELIC GAUGE

(Used in All Models)

CATALOG DATA

Range, Inches of Water:	0-8.0
Minor Divisions:	.20
Ambient temperature range:	20° to 140° F.
Rated total pressure:	-20" Hg. to 15 psig.+
Overpressure:	Relief plug opens at approximately 25 psig.
Connections:	1/8" NPT female high and low pressure taps duplicated - one pair side and one pair back.
Accuracy:	Plus or minus 2% of full scale (3% on - 0 and 4% on - 00 ranges), throughout range at 70°F.
Weight:	1 lb. 2 oz.

BALDOR 5 HP ELECTRIC MOTOR

(Used in Model PP-500)

CATALOG DATA

CATALOG ITEM: VM3613T	"C" DIMENSION: 16.56
HORSEPOWER: 5	EFF @ FULL LOAD: 85.5
RPM: 3450	VOLT CODE: E
NEMA FRAME: 184TC	SHIPPING WEIGHT: 98
TYPE: 3628M	MULTIPLIER SYM: L1

MOTOR DATA

VOLTAGE: 208-230/460	ENCLOSURE: TEFC
FULL LOAD AMPS: 13.2-12/6	MOUNTING: F1
PHASE: 3	BASE: N
HERTZ: 60	D.E. BEARING: 6206
POLES: 02	O.D.E. BEARING: 6205
CODE: 02	ROTATION: R
DESIGN: B	SPEC NUMBER: 36A03X100
SERVICE FACTOR: 1.15	RATING: 40C

RATING - NOMINALS

Rated Output	5 HP
Volts	208-230/460
Full Load Amps	13.2-12/6
Speed	3450
Hertz	60
Phase	3
NEMA Design Code	B
LR KVA Code	K
Efficiency	87.5
Power Factor	92
Service Factor	1.15
Rating - Duty	40C AMB-CONT

CHARACTERISTICS

Break Down Torque	32
Locked-Rotor Torque	27
Starting Current	56
No-Load Current	1.8
Line-line Resistance @ 25 Degrees C	2.4
Temperature Rise, in degrees C @ FL	N/A

LOAD CHARACTERISTICS - TESTED

% of Rated Load	25	50	75	100	125	150	S.F.
Power Factor	64	83	89	92	93	94	93
Efficiency	82.7	87.8	88.4	87.8	86.5	84.7	87
Speed (rpm)	3565	3533	3498	3462	3421	3378	3437
Line Amperes	2.3	3.3	4.6	5.9	7.3	8.9	6.7

BALDOR 5 HP EXPLOSION PROOF ELECTRIC MOTOR

(Used in Model PP-500XP)

CATALOG DATA

CATALOG ITEM: VM7072T	"C" DIMENSION: 18.87
HORSEPOWER: 5	EFF @ FULL LOAD: 85.5
RPM: 3450	VOLT CODE: E
NEMA FRAME: 184TC	SHIPPING WEIGHT: 98
TYPE: X3628M	MULTIPLIER SYM: L1

MOTOR DATA

VOLTAGE: 208-230/460	ENCLOSURE: XPFC
FULL LOAD AMPS: 13.2-12/6	MOUNTING: F1
PHASE: 3	BASE: N
HERTZ: 60	D.E. BEARING: 6206
POLES: 02	O.D.E. BEARING: 6205
CODE: 02	ROTATION: R
DESIGN: B	SPEC NUMBER: 36E396X100
SERVICE FACTOR: 1.00	RATING: 40C

RATING - NOMINALS

Rated Output	5
Volts	208-230/460
Full Load Amps	13.2-12/6
Speed	3450
Hertz	60
Phase	3
NEMA Design Code	B
LR KVA Code	K
Efficiency	85.5
Power Factor	93
Service Factor	1.15
Rating - Duty	40C AMB-CONT

CHARACTERISTICS

Break Down Torque	29
Locked-Rotor Torque	22
Starting Current	47
No-Load Current	1.4
Line-line Resistance @ 25 Degrees C	2.86
Temperature Rise, in Degrees C @ FL	N/A

LOAD CHARACTERISTICS - TESTED

% of Rated Load	25	50	75	100	125	150	S.F.
Power Factor	75	88	93	94	95	95	95
Efficiency	80.2	85.8	86.5	85.7	84.3	82.2	84.9
Speed (rpm)	3555	3517	3475	3431	3386	3332	3404
Line Amperes	2.1	3.2	4.5	5.8	7.2	8.7	6.8

CROUSE-HINDS MANUAL LINE STARTER AND ENCLOSURE

(Used in Model PP-500XP)

Cl. I, Div. 1 & 2 Groups C,D	Explosion Proof
Cl. II, Div. 1, Groups E,F,G	Dust-Ignition Proof
Cl. II, Div. 2, Group F,G	Raintight
Cl. III	Wet Locations
NEMA 3,7CD,9EFG,I2	

FEATURES

- Operating Handle may be padlocked in either "ON" or "OFF" positions
- Bodies have bottom drilled and tapped entrances for power conduits plus one at the top for control conduit.

CERTIFICATIONS & COMPLIANCES

- | | | |
|---|--------------------------------|---------------------------|
| • NEC/CEC: | • <u>Volt</u> | • <u>RMS Symm-Amperes</u> |
| • Class I, Division 1 & 2; Groups C,D | • 240 | • 65,000 |
| • Class II, Division 1; Groups E,F,G | • 480 | • 50,000 |
| • Class II, Division 2; Groups F,G | • 600 | • 25,000 |
| • Class III | | |
| • UL Standards UL 698 | • CSA Standard: C22.2 No. 14 | |
| • UL Subject 2062 - High AIC rating (interrupting Capacity) | • NEMA/EEMAC: 3, 7CD, 9EFG, 12 | |

STANDARD MATERIALS

- Body and covers and toggle operator - copper-free aluminum
 - Cover bolts, washer and retractile springs - stainless steel
 - Operating shaft - stainless steel
 - Interior parts - sheet steel, electrogalvanized
- *National Electrical Code is a Registered Trademark of the National Fire Protection Association.

TROUBLESHOOTING

Problem	Probable Cause	Remedy
Unit Fails To Start	<ol style="list-style-type: none"> 1. Improper Power Connection 2. Breaker Tripped 3. Improper/Faulty Electrical Connection 	<ol style="list-style-type: none"> 1. Ensure Motor Starter Wired For Correct Current 2. Reset Breaker 3. Repair/Replace Electrical Connections.
Unit Stops Running	<ol style="list-style-type: none"> 1. Incorrect Power Supply 2. Overload Relay Heaters Failed 3. Breaker Tripped 	<ol style="list-style-type: none"> 1. Ensure Unit Connected To Correct Power Supply 2. Replace Overload Relay Heaters 3. Reset Breaker
No/Low Air Flow	<ol style="list-style-type: none"> 1. Blower Rotating In Wrong Direction 2. Filter Clogged 3. Ducts Blocked 	<ol style="list-style-type: none"> 1. Ensure Unit Is Wired Correctly For Clockwise Rotation 2. Replace Clogged Filter 3. Remove Blockage
Loud Clanking Noises	<ol style="list-style-type: none"> 1. Object Obstructing Rotation Of Blower 2. Blower Misaligned 	<ol style="list-style-type: none"> 1. Remove Object To Allow Blower To Rotate Freely 2. Adjust Blower To Proper Position On Motor Shaft

AirVerte[®]