



Reyrolle  
Protection  
Devices

## 7SG11 Argus 1-6

Overcurrent Relay

Answers for energy

**SIEMENS**

# Contents

## Technical Manual Chapters

1. User Manual
2. Technical Reference
3. 1 Diagrams and Parameters
4. Argus 2 Diagrams and Parameters
5. Argus 4 Diagrams and Parameters
6. Argus 6 Diagrams and Parameters

The copyright and other intellectual property rights in this document, and in any model or article produced from it (and including any registered or unregistered design rights) are the property of Siemens Protection Devices Limited. No part of this document shall be reproduced or modified or stored in another form, in any data retrieval system, without the permission of Siemens Protection Devices Limited, nor shall any model or article be reproduced from this document unless Siemens Protection Devices Limited consent.

While the information and guidance given in this document is believed to be correct, no liability shall be accepted for any loss or damage caused by any error or omission, whether such error or omission is the result of negligence or any other cause. Any and all such liability is disclaimed.

# 7SG11 Argus

Overcurrent Protection Relays

## Document Release History

This document is issue 2010/02. The list of revisions up to and including this issue is:

Pre release

2010/02	Document reformat due to rebrand
2006/08	Fourth issue: VA Tech references replaced by Siemens Protection Devices Ltd
2006/03	Third issue: Additional modifications, software revision histories updates
2004/05	Second issue:- Improved CBF function, additional metering , Modbus protocol, extended timers added
2002/12	First issue

## Software Revision History

Since introduction in 1995, Argus overcurrent relays have undergone a number of modifications to improve functionality and features provided. The content of this manual is directly applicable to the software versions listed below. When used with other versions minor variations may be noticed. A detailed release history for each type is given in the appropriate Diagrams and Parameters document.

Argus 1 and Argus 2	2434H80023 R10	release date November 2005
Argus 2-500	2434H80040 R8	release date November 2005
Argus 4 and Argus 6	2716H80005 R5	release date March 2005

## Hardware Release History

Since introduction in 1995, Argus overcurrent relays have undergone a number of minor changes to hardware. The content of this manual is directly applicable to Argus hardware in Epsilon cases produced since March 2002. When used with earlier versions, minor variations may be noticed. A detailed release history for each type is given in the appropriate Diagrams and Parameters document.

The copyright and other intellectual property rights in this document, and in any model or article produced from it (and including any registered or unregistered design rights) are the property of Siemens Protection Devices Limited. No part of this document shall be reproduced or modified or stored in another form, in any data retrieval system, without the permission of Siemens Protection Devices Limited, nor shall any model or article be reproduced from this document unless Siemens Protection Devices Limited consent.

While the information and guidance given in this document is believed to be correct, no liability shall be accepted for any loss or damage caused by any error or omission, whether such error or omission is the result of negligence or any other cause. Any and all such liability is disclaimed.

## Contents

Section 1: Relay Description .....	4
1.1 Overview .....	4
1.2 Hardware .....	4
1.3 Functionality .....	6
Section 2: Operation Guide .....	12
2.1 User Interface Operation .....	12
2.2 Operation using Reydisp Evolution (IEC 60870-5-103 comms only) .....	15
Section 3: Installation .....	16
3.1 Unpacking, Storage and Handling .....	16
3.2 Recommended Mounting Position .....	16
3.3 Relay Dimensions .....	16
3.4 Wiring .....	16
3.5 Fixings .....	17
3.6 Ancillary Equipment .....	17
Section 4: Commissioning .....	18
4.1 Before Testing .....	18
4.2 Tests .....	19
4.3 Putting into Service .....	27
4.4 Commissioning Record Tables .....	28
Section 5: Testing and Maintenance .....	35
5.1 Periodic Tests .....	35
5.2 Maintenance .....	35
5.3 Troubleshooting .....	35
5.4 Defect Report .....	37

## List of Figures

Figure 1-1	Overcurrent Characteristics .....	7
Figure 2-1	Menu Structure for Argus 1, 2, 4 and 6 Relays.....	13
Figure 4-1	Directional Earth Fault Boundary System Angles .....	23
Figure 4-2	Directional Phase Fault Boundary System Angles .....	23
Figure 4-3	Secondary Injection Test Circuit .....	33
Figure 4-4	Directional Test Circuit .....	33
Figure 4-5	Two-out-of-three Directional Test Circuit .....	33
Figure 4-6	Phase to Earth Primary Injection Test Circuit .....	33
Figure 4-7	Phase to Phase Primary Injection Test Circuit .....	33
Figure 4-8	Resultant Applied Voltages and Currents for a Simulated Earth Fault Condition using Load Current .....	34

## List of Tables

Table 3-1	Wire crimp sizes .....	17
Table 4-1	IDMTL Timing Characteristic (Time in Seconds) .....	20
Table 4-2	Connections for Directional Polarity .....	22
Table 4-3	Limits of Operate Pick-up Relay Angle Boundaries .....	23
Table 4-4	Pick-up/Drop-off Results.....	28
Table 4-5	Timing Characteristic Results .....	28
Table 4-6	Lowset setting results .....	28
Table 4-7	Highset 1 setting results .....	29
Table 4-8	Highset 2 setting results .....	29
Table 4-9	Lowset timing results .....	29
Table 4-10	Highset 1 timing results .....	29
Table 4-11	Highset 2 timing results .....	29
Table 4-12	Pick-up/Drop-off Results for SEF/REF .....	30
Table 4-13	SEF/REF Timing Results.....	30
Table 4-14	Pick-up/Drop-off Results for CBF Level Detector .....	30
Table 4-15	Circuit Breaker Fail Timing Results .....	30
Table 4-16	Directional Boundaries of Operation.....	31
Table 4-17	Auto-reclose Sequences and settings .....	31
Table 4-18	Primary Injection Results.....	32
Table 5-1	Troubleshooting Guide .....	35

## Section 1: Relay Description

### 1.1 Overview

The Argus range of overcurrent protection combines the power and flexibility of microprocessor technology with decades of experience in the field of overcurrent protection and auto-reclose. A wide range of protection elements are supplemented by advanced features such as control, metering, data storage and fibre-optic based communications.

#### Features

- IDMTL phase overcurrent stage (50/51)
- 3 DTL phase overcurrent stages (50)
- IDMTL earth-fault stage (50N/51N)
- 3 DTL earth-fault stages (50N)
- 2 instantaneous and DTL SEF/REF stages with harmonic rejection (50N)
- Trip circuit supervision (74TC)
- Circuit breaker failure protection (50BF)
- Single pole, three pole and four pole variants
- True RMS measurement
- Status inputs with independent pick-up and drop-off timers and logic inversion to reduce scheme engineering
- Flexible supply voltage ranges
- Low AC/DC burden
- Eight independent settings groups
- Self, hand and electrical reset contacts
- Extensive fault, sequence of event and disturbance recorder
- IEC60870-5-103 fibre-optic communications
- Modbus RTU communications
- Continuous self-supervision of operation and power supply

### 1.2 Hardware

#### 1.2.1 Case

The Argus relay is housed in a drawout case designed for either panel mounting or modular 19" racking systems.

The case is 4U (177 mm) high and will be of size 4, size 6 or size 8 width.

The chassis of the Argus can be withdrawn from the case by pulling on the handles provided. Shorting contacts ensure that CT circuits and normally closed contacts remain short-circuited. All output contacts will be disconnected before any input contacts in order to prevent maloperation.

The rear terminals are designed to take two wires terminated using ring crimps and are secured using M4 screws.

#### 1.2.2 Front Cover

After the Argus has been commissioned it is sealed by fixing a clear plastic cover over the front. This allows the user to see the entire front of the relay, but only allows access to the ▼ and ► buttons, allowing all of the menus to be viewed but not changed. The only 'action' which is permitted is to reset the Fault Data Display, latched output relays and the trip LED by using the **TEST/RESET** function of the ► button.

#### 1.2.3 User Interface / Fascia

The user interface is designed to provide a user friendly method of entering settings and retrieving data from the Argus relay.

#### Relay Information

The Reyrolle logo appears in the top left corner of the Argus.

At the top right an information label is provided which contains the range name (Argus 1, Argus 2, Argus 4 or Argus 6), model number, serial number and nominal ratings of energising quantities.

## Liquid Crystal Display

A 2 line, 16 character backlit liquid crystal display (LCD) is used to present settings, instruments and fault data in a textual format. The display backlighting is turned off to conserve power if no pushbuttons are pressed for 5 minutes. After an hour, the whole display is de-activated, except in the case of the instruments, which remain visible permanently.

### 'Protection Healthy' LED

This green LED indicates that DC volts have been applied to the Argus and that the relay is operating correctly. If a permanent fault is detected by the internal watchdog, then this LED will continuously flash.

### 'Starter' LED

This self-resetting yellow LED indicates that any pole is measuring current above the IDMTL/DTL current setting.

### 'Trip' LED

This latching red LED indicates that a trip, as defined by customer setting, has occurred. Such a trip may have been issued by any of the protection functions. The user will be given more detailed information concerning the trip from the LCD screen.

After being energised the LED can be reset by pressing the **TEST/RESET** key, or by energising a status input which has been programmed to reset latched relays and the trip LED.

### 'CB Open' LED

*Argus 4 and Argus 6 only.*

This green LED indicates that the circuit breaker is open.

### 'CB Closed' LED

*Argus 4 and Argus 6 only.*

This red LED indicates that the circuit breaker is closed.

## Keypad

Five keys are provided to control the functions of the Argus by moving around the menu display. They are labelled: **▲**, **▼**, **ENTER**, **CANCEL** and **▶**. The **▶** key is also labelled **TEST/RESET**.

Only two push buttons are accessible when the front cover is in place. These are the **▼** and **▶** buttons which allow the user to view all displays, including settings, but not to change setting values.

## 1.2.4 Current and Voltage Inputs

### Current Inputs

Two types of current input are incorporated within the Argus range. One type of input is used for phase fault and earth fault protection, while the other is used for sensitive earth fault and restricted earth fault protection. The current inputs can be configured for operation with either 1A or 5A transformers. The appropriate connections are required on the terminal blocks and the CT rating must be set as required.

### Voltage Inputs

*Argus 2 and Argus 6 only* - Voltage inputs are used for setting the direction of the overcurrent elements and up to 4 voltage inputs are provided.

In most models voltage inputs for the phase voltages must be connected phase-phase, while a separate open-delta VT must provide the neutral voltage. In some models, however, the option is given to connect 3 voltage inputs in a star configuration.

Each voltage input is capable of being connected to VTs with a nominal 63.5V or 110V secondary voltage.

## 1.2.5 Status Inputs and Output Relays

Four configurations of digital I/O are available:

- 1 status input, 7 output relays (3 changeover, 4 normally open)
- 3 status inputs, 5 output relays (3 changeover, 2 normally open)
- 5 status inputs, 11 output relays (3 changeover, 8 normally open)

- 9 status inputs, 7 output relays (3 changeover, 4 normally open)

Single pole Argus relays are only available with 1 status input and 7 output relays.

### Status Inputs

Status inputs can be programmed to perform one or more of the following functions:

- Switch to an alternative settings group
- Trigger the storage of a waveform record
- Trigger a textual fault record
- Trigger operation of the  $I^2$  summation and trip count features
- Inhibit operation of any one or more protection functions
- Monitor the health of the tripping circuit
- Synchronise the real-time clock
- Reset of latched output contacts
- Reset of counter instruments
- Start an auto-reclose sequence
- Register a general alarm
- Initiate an external circuit breaker fail condition

Additionally, each input can be independently programmed to operate with time delayed pick-up and/or time delayed drop-off. The status inputs have a default pick-up delay setting of 20ms which provides security against operation in the presence of an a.c. input voltage. If instantaneous operation is preferred then the pick-up delay should be set to zero.

It is also possible to invert the operation of a status input. If an input is configured to be inverted, then any function assigned to that input becomes active upon de-energisation of the input.

### Output Relays

Outputs are user programmable to operate from any or all of the protection characteristics. In addition they can be programmed to generate outputs from the  $I^2$  summation alarm, the trip counter alarm, the status inputs and the self-monitoring feature (watchdog). In their normal mode of operation, output contacts remain energised for the duration of fault current, but with a user programmable minimum time. Alternatively, outputs can be programmed to operate as latching contacts if required. Latched output relays can be reset either by pressing the **TEST/RESET** button, by sending an appropriate communications command or electrically via a status input. A trip test feature is provided to operate the output contacts.

## 1.2.6 Auxiliary Supply

A d.c. voltage of the appropriate level must be supplied onto the correct terminals on the rear of the case.

## 1.2.7 Communications

A pair of fibre-optic ST<sup>TM</sup> (BFOC/2.5) bayonet connectors, optimised for glass-fibre, are fitted to the rear of the case – one transmit and one receive. These are used as the standard interface for all communications with the Argus. An alternative RS485 option is available.

The Argus is supplied using IEC 60870-5-103 as its default communications. Modbus is available via a setting in the communications menu.

## 1.2.8 Terminals

These are of a modular design. Depending on the model either 1, 2 or 3 terminal blocks will be fitted with 28 terminals per block. All inputs and outputs (except for the serial communications interface) are made through these connectors.

# 1.3 Functionality

## 1.3.1 Protection

Argus provides comprehensive overcurrent protection with programmable input and output matrix. In addition 8 setting groups enable a flexible approach to protection settings.

Up to four current measuring inputs are available in the Argus relays and these may be phase-fault overcurrent, earth-fault overcurrent or SEF/REF depending on the model.



### 1.3.1.1 Phase-fault and Earth-fault Overcurrent

Phase-fault and earth-fault inputs each have four independent overcurrent elements. Each has a current setting and timing characteristic as illustrated in Figure 1-1.

The principal overcurrent element is selectable between IDMTL (inverse definite minimum time lag) and DTL (definite time lag) characteristics. Four IDMTL curves are available, namely normal inverse (NI), very inverse (VI), extremely inverse (EI) and long time inverse (LTI). The IDMTL algorithms operate correctly for developing faults where current varies with time.

Two independent highsets and an independent lowset are included with shaped instantaneous characteristics and DTL. The instantaneous outputs are designed for transient free operation where high values of system X/R are experienced.

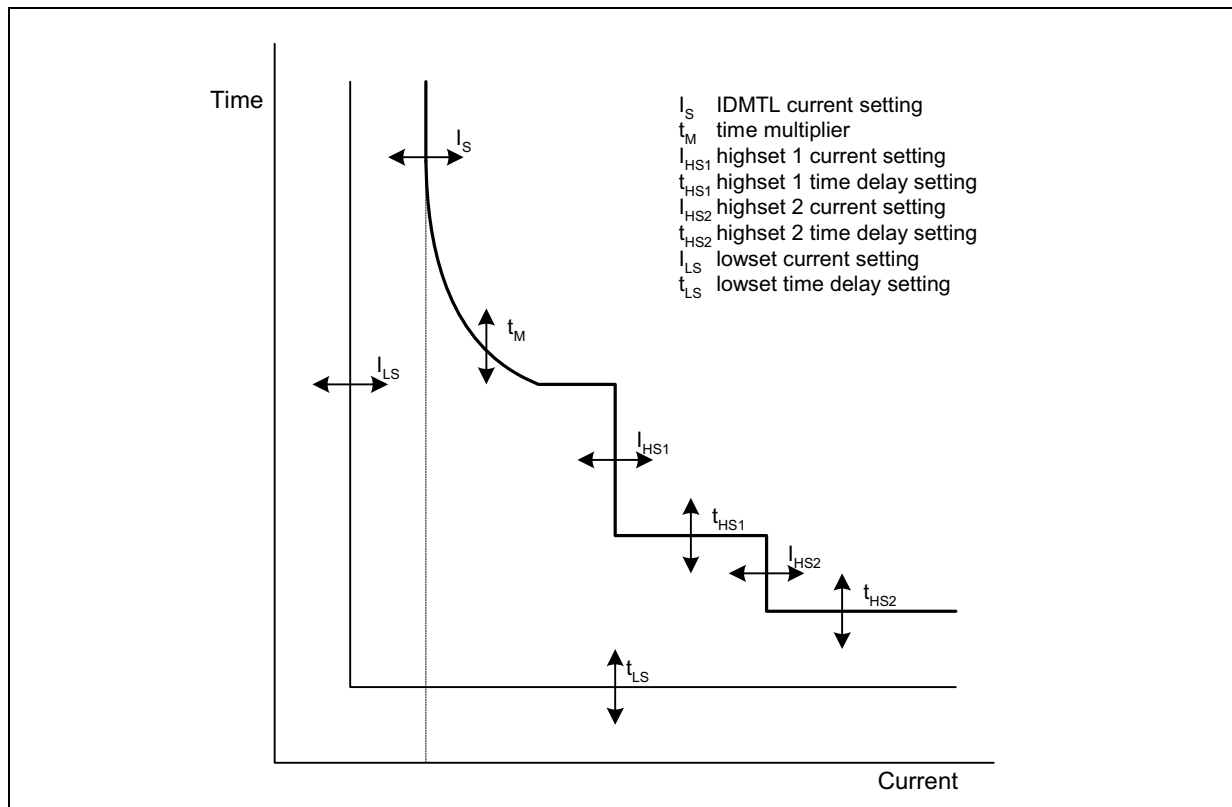


Figure 1-1 Overcurrent Characteristics

### 1.3.1.2 Sensitive Earth-fault/Restricted Earth-fault

Sensitive earth-fault and restricted earth-fault protection schemes are achieved with identical internal functionality. They incorporate filtering for rejection of second, third and higher harmonics of the power system frequency.

Two DTL timers and a lowset characteristic are provided. The lowset does not have an independent current setting in this case. The delayed reset function operates on the two DTL timers.

### 1.3.1.3 Directional Control

*Argus 2 and Argus 6 only.*

Directional elements are available for phase-fault and earth-fault as an ordering option. Bi-directional elements provide independent characteristic, current and time settings for each direction of each overcurrent stage. In models with three phase-fault directional elements, single-phase or two-out-of-three directional decisions are available.

In most models, the phase fault characteristic angles are selectable from +30° and +45°; the earth-fault characteristic angle is selectable from 0°, -15°, -45° and -65°.

In Argus 2 models with voltage and power measurement, the phase-fault and earth-fault characteristic angles are selectable to any angle between -90° and +90° in 1° steps.

#### 1.3.1.4 Voltage Protection

*Certain Argus 2 models only.*

A three-phase voltage element with definite time delay is provided which can be used to provide a trip or alarm output, or can be set to block any of the overcurrent elements. The element can be set to undervoltage or overvoltage with variable hysteresis. Overcurrent blocking occurs from each phase independently, but a common trip output is provided.

#### 1.3.1.5 Cold Load Pickup

*Argus 4 and Argus 6 only.*

The Argus can apply higher current settings with longer time delays, after the circuit breaker has been open for a programmable time. On closing of the circuit breaker these higher settings are applied for a programmable time or until the measured current has fallen to normal levels.

#### 1.3.1.6 Circuit Breaker Fail

The circuit breaker fail function operates by monitoring the current following a trip signal and issues an alarm if the current does not cease within a specified time interval. A two-stage time delayed output can be used to operate output contacts to retrip the same circuit breaker, using a second trip coil, or to backtrip an upstream circuit breaker.

The CBF timer 1 starts to operate following a trip output from any one of the protection algorithms or an external input, providing there is current above the circuit breaker fail current setting. An output is issued after the CBF timer 1 delay. If current is still above the setting, CBF timer 2 then begins to operate and will issue a second output after the CBF timer 2 delay.

### 1.3.2 Control

#### 1.3.2.1 Autoreclose

*Argus 4 and Argus 6 only.*

Integrated auto-reclose is available as an ordering option. The Argus incorporates a 5 trip/4 close auto-reclose sequence that can be initiated by an internal or external signal. For each type of protection trip - phase-fault, earth-fault, SEF or external - a separate sequence of instantaneous and delayed trips is available. Programmable dead times and reclaim times with a wide setting range and integrated sequence co-ordination enable virtually all distribution auto-reclose schemes to be achieved.

### 1.3.3 Plant Monitoring

#### 1.3.3.1 Trip Circuit Supervision

An Argus relay can monitor its associated trip circuit by configuring one of its status inputs using the 'Trip Circuit Fail' setting and connecting the input into the trip circuit (refer to the applications guide for details of how this is achieved). Indication is then given instantaneously of 'Trip Circuit Failure' should a fault be detected, this display also identifies which input has detected the fault. Since the status inputs can be programmed to operate output contacts, an alarm output can also be generated from the trip circuit supervision feature.

#### 1.3.3.2 Circuit Breaker Maintenance

The  $I^2$  summation feature and the trip counter provide circuit breaker condition monitoring. Alarm outputs with programmable settings are available for both features.

This information is accessed either from the front panel or via the communications interface. The values of current used for the  $I^2$  summation are those measured at the time of issuing a trip signal. An  $I^2$  sum is generated for each phase element and the highest value is used for alarm and display purposes. It is also possible to initiate the  $I^2$  summation algorithm from an external tripping device via the status input if required.

The trip count and the  $I^2$  summation count can be reset by either of two methods:

- when viewing the appropriate instrument screen and pressing the **TEST/RESET** button
- in the settings menu using appropriate reset setting

### 1.3.4 Measurements

Analogue values can be displayed in primary or secondary quantities on the LCD screen. In addition the values can be obtained via the communications port.

### Available Instruments

- Primary current – RMS values on a phase-by-phase basis, indicated by upper case letters, e.g. A, B, C, E, SE (sensitive earth)
- Secondary current – RMS values on a phase-by-phase basis, indicated by lower case letters, e.g. a, b, c, e, se
- Primary phase voltages \*
- Primary phase-phase voltages \*
- Secondary voltages \*
- Apparent power and power factor \*
- Real and reactive power \*
- WHr forward and reverse \*
- VarHr forward and reverse \*
- Rolling and Max demand Ia, Ib, Ic
- Rolling and Max demand W\*
- Rolling and Max demand Var\*
- Direction \*
- Autoreclose status \*
- Output contacts
- Status inputs
- Trip circuit healthy/failure
- Trip counters
- I<sup>2</sup> summation
- Number of waveform and event records stored
- Time and date
- Starters
- Power on counter

\* Instruments marked \* are not available in all models – consult ordering information and the appropriate 'Diagrams and Parameters' document.

Note: The rolling demand measurements can be configured to measure over a rolling window with the following ranges:

OFF, 0.25, 0.5... 1.0, 1.5... 5.0, 6.0... 12.0, 16.00... 24.0 hours

### General Alarm Screens

The Argus has an independent display function that provides up to five General Alarm screens, each of which may be programmed by the user to display a message associated with an external alarm. Within the System Configuration Menu, each General Alarm message can be text edited by the user to display up to 13 characters. Also, each General Alarm can be user mapped to any status input, via the Status Configuration Menu, so that on energisation of that input the associated alarm message is automatically displayed. Where more than one General Alarm is raised then the display will scroll right to left to show all energised screens sequentially, with screens separated by a '+' sign. If required, more than one alarm may be mapped to a single status input, allowing long messages to be displayed.

### Default Instrumentation Screens

The menu presentation of the various instruments allows the user to view a single screen at a time. However, for in-service use, it is desirable that a small number, of high interest, user selectable, screens are presented automatically by default without user intervention e.g. Ammeter display of the Primary Load Currents and in addition the TRIP Count.

The screens of interest to the user, e.g. those required to be presented to a visiting engineer for record purposes, can be selected by the user by pressing ENTER when viewing the required screen. A 'Screen Set As Default' message will be flashed up and ' ' will appear at top right of that screen. To cancel a screen default, scroll to that screen and press ENTER, 'Screen Cleared As Default' will be flashed up and the ' ' symbol will be cleared.

If no button is pressed for the duration of the user set "Default Time Delay", then each Default Screen is displayed in turn, for five seconds each. If any General Alarm is raised, then the General Alarm screen is presented in the Default Screen sequence. The General Alarm screen, which has a scrolling display will present one pass of its display. Any key press while in default screens will result in a return to the "Relay Identifier" screen at the top of the menu structure.

### 1.3.5 System Data

Data records are available in three forms: fault records, waveform records and event records.

### 1.3.5.1 Time Stamping

All records are stamped with time and date using the Argus' real-time clock feature. If the Argus is de-energised then a capacitor provides a back-up supply to the real-time clock for a limited period. Time and date can be set either via the fascia using appropriate commands in the System Configuration Menu, or via the communications interface. In the latter case, Argus relays connected in a communications network can be synchronised by a global command.

Synchronising pulses can be received via a status input. To use this feature one of the status inputs must be assigned to the 'Clock Sync' feature in the Status Configuration Menu. Additionally the 'Clock Sync Period' setting in the System Configuration Menu should be set either to 'Seconds' or to 'Minutes' as appropriate, depending on the period of the synchronising signals expected from the controlling device. If 'Seconds' are selected then energisation of the selected status input will result in the clock being synchronised to the nearest second with milliseconds set to zero. If 'Minutes' are selected then the clock is synchronised to the nearest minute with seconds and milliseconds set to zero.

### 1.3.5.2 Fault Records

The last 5 fault records are available from the Argus fascia with time and date of trip, measured quantities and type of fault.

When issuing a trip output under fault conditions the Argus illuminates its TRIP LED, stores a fault record and displays the fault indication screen. The fault indication screen displays a summary of the fault record, giving immediate, simple information on what has occurred. It displays date (DD/MM), time (HH:MM:SS) and the poles which were picked up when the trip signal was issued, for example:

```
25/04 17:25:51
TRIP A E
```

This display is held until the **TEST/RESET** button is pressed, upon which the LED turns off and any latched output relays are reset. The Argus enters 'Fault Data Display Mode' at which point the fault indication screen is replaced with a more detailed scrolling fault data display.

```
Fault 1
<<<fault data>>>
```

This shows date and time of fault, the active settings group at the point of trip, plus, for each pole the elements picked up and the current measured at the time of trip. The information scrolls along the bottom line of the display. External alarms are also shown in the fault record.

e.g. 12/05/04 15:32:47.2525 G1 PHASE A LS <IDMTL> HS1 HS2 IA = 12.32xIn...

The fault record is viewed in the 'Fault Data Display Mode' of the menu display system and can be viewed again at a later date. Fault records are stored for the previous five faults. The five displays are numbered from 1 to 5 with fault 1 indicating the most recent record. It is necessary to define a 'fault' for these purposes. Depending on the application, some of the protection outputs may be used for alarm purposes rather than for tripping. In such cases it would be undesirable for the Argus to light its TRIP LED and give fault indication.

Therefore, a 'Fault Trigger' setting is included to allow the fault condition to be defined by selecting any combination of output relays as tripping outputs. The TRIP LED and the fault record storage will be triggered when any of the selected output relays are energised. Note that a trip output can still be generated even if the 'fault trigger' setting is not used, but no trip indication is given. Fault records are stored in non-volatile memory.

### 1.3.5.3 Disturbance Recorder

The waveform record feature stores analogue and digital information for all current inputs, status inputs and output relays. On some relays voltage signals are also stored. The 'Waveform Trigger' setting is used to enable the waveform record feature. Waveform storage is triggered by operation of any function selected in the 'waveform trigger' setting. In addition, a record can be triggered remotely via a status input or via the serial communications interface. Waveforms are stored in a 1 second, rolling 'time window'. The 1 second data window has a settable pre-fault triggering capability. There is capacity to store five waveform records, with any new record over-writing the oldest. All records are time and date stamped. Waveform records are stored in RAM with a capacitor providing back-up during breaks in auxiliary supply.

The waveform record store can be erased when viewing the "waveforms" instrument screen and pressing the **TEST/RESET** button.

### 1.3.5.4 Sequence of Event Records

The Argus event recorder feature allows the time tagging of any change of state. Each event is logged with the full date and time and actual event condition every 2.5msec. The following events are logged:

- Change of setting (though not the actual setting changes). Also indication of which group of settings is active
- Change of state of output relays
- Change of state of status inputs
- Change of state of any protection characteristic
- Trip indication reset
- Trip test
- Trip supply failure
- Circuit Breaker maintenance alarms
- Circuit breaker failure

The event storage buffer holds 500 records. When the event buffer is full, then any new record overwrites the oldest.

Event records are stored in RAM with a capacitor providing back-up during breaks in auxiliary supply.

The event record store can be erased when viewing the “events stored” instrument screen and pressing the **TEST/RESET** button.

### 1.3.6 General

#### Multiple Settings Groups

Argus relays provide eight alternative settings groups, making it possible to edit one group while the protection algorithms operate using another ‘active’ group. The Argus can then be switched from one group of settings to another to suit alterations in the power system configuration. A change of group can be achieved either locally at the fascia, remotely via a communications interface command or by energisation of a status input. On models with a voltage element, this can also be used to change settings group.

For setting group change by status input, the ‘Settings Group Select’ setting is used to configure any one (or more) of the status inputs to select a settings group. The selected group is then made active if the status input is energised and remains active for as long as the input remains energised.

If multiple status inputs are energised, the lower (or lowest) number status input takes precedence. For instance, if status input 1 activates settings group 5 and status input 3 activates settings group 2, and both status inputs are energised, the Argus would operate in settings group 5.

#### Self Monitoring

The Argus incorporates a number of self-monitoring features listed below, each of which initiates a reset sequence that can be used to generate an alarm output. In addition, the Protection Healthy LED gives visual indication.

- Power supply watchdog
- Microprocessor watchdog
- Program memory test using CRC

Any failure is detected with sufficient time warning so that the microprocessor can be shut down in a safe and controlled manner.

#### Password Feature

The programmable password feature enables the user to enter a 4 character alpha-numeric code. As soon as the user attempts to change a setting the password is requested before any setting alterations are allowed. Once the password has been validated, the user is said to be “logged on” and any further changes can be made without re-entering the password. If no more changes are made within 1 hour then the user will automatically be “logged out”, re-enabling the password feature. Note that the password validation screen also displays a numerical code. If the password is lost or forgotten, authorised personnel can communicate this code to Siemens Protection Devices Limited, and the password can be retrieved. The Argus is supplied with the password set to “NONE” which means the feature is de-activated.

## Section 2: Operation Guide

### 2.1 User Interface Operation

The basic settings/displays flow diagram is shown in Figure 2-1. This diagram shows the main modes of display: Linesman Mode (Argus 4 and 6 only), Settings Mode, Instrument Mode and Fault Data Mode.

When the Argus leaves the factory all data storage areas are cleared and the settings set to default values as specified in the Argus Overcurrent Technical Reference document. When the Argus is first powered-on the screen will display the default relay identifier and 'Factory Settings'. The identifier can be changed to a user definable identifier or code if the user prefers. Once any setting changes have been made the 'Factory Settings' text will be replaced by 'Relay Settings'.

On each subsequent power-on the screen that was showing before the last power-off will be displayed.

The menu system is navigated as shown in Figure 2-1. Note, however that some sub-menus and screens are relevant to certain models only and will not always appear. This is indicated in the diagram. The exact list of settings and instruments available in each model is given in the appropriate Diagrams and Parameters document.

The five keys have the following functions:

Up (▲), down (▼) and right (▶) keys – used to navigate the menu system

**ENTER** key – when a setting is being displayed this key will enter edit mode for the setting (see section 2.1.1). When in edit mode pressing **ENTER** will accept the setting change. When an instrument is being displayed pressing **ENTER** will toggle the instruments default screen status on and off (see section 2.1.2.1).

**CANCEL** key – when a setting is being edited this key will cancel the edit without changing the setting. At all other positions **CANCEL** will move back up the menu system (in the direction of the main menu).

**TEST/RESET** key – when the main menu is visible **TEST/RESET** will briefly light all LEDs in order to test their operation. After a trip occurs and the summary fault record is being displayed **TEST/RESET** will reset the trip LED and any hand reset contacts before displaying the scrolling fault display. When an instrument which records a count is being displayed (e.g. number of CB operations) pressing **TEST/RESET** will allow the count to be reset (see section 2.1.2.2). At all other times the right (▶) function of this key is available for menu navigation.

#### 2.1.1 Settings

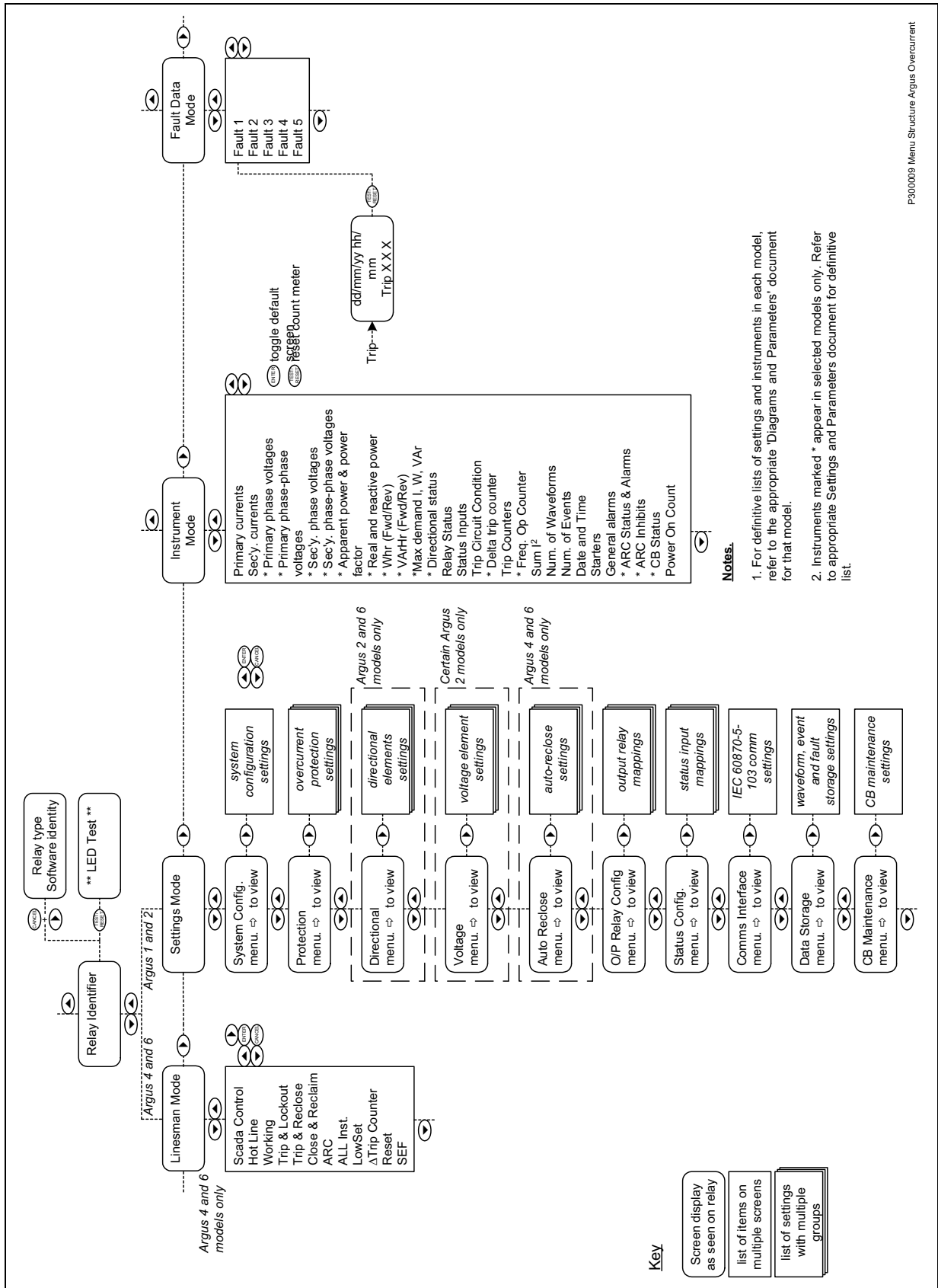
While a setting (or other editable value – e.g. in Linesman mode) is being displayed on the screen the **ENTER** key can be pressed to edit the setting value. If the Argus is password protected the user will be asked to enter the password as described below. If an incorrect password is entered editing will not be permitted.

While a setting is being edited flashing characters indicate the edit field. Pressing the up (▲) and down (▼) keys will increment and decrement the value of the field within the valid limits of the setting. If the up and down keys are held on the rate of scrolling will increase.

On a multi-field setting (e.g. text settings or CT ratios) pressing the right (▶) key will move the edit point to the next field.

Once editing is complete pressing **ENTER** stores the new setting value into the non-volatile memory. **The setting change is effective immediately** unless any protection element is operating (above setting) in which case the change becomes effective when no elements are operating.

If during editing the **CANCEL** key is pressed the edit mode is exited, the setting change is discarded and the original value is redisplayed.



P300009 Menu Structure Argus Overcurrent

Eight settings groups are stored within the Argus. Only one of these is active at a time and only one can be displayed at a time. Some settings have a common value across all groups. If a setting has different values across the groups this is indicated by G<sub>n</sub> in the top left of the display while the setting is being displayed, where n is the number of the current display group.

The active group can be switched from one to another using the 'Active Group' setting in the 'System Config.' sub-menu. Similarly, the current display group is controlled by the 'Display Group' setting.

#### 2.1.1.1 Password Entry

If, at any point, a password is required the screen will display 'Enter password' and a four-character field. The password is entered, as described for settings changes above. On pressing **ENTER**, if the password is correct, the user is "logged in" and editing will be allowed. The user will remain logged in for an hour after the last key press after which he/she will be "logged out" and the password must be re-entered for further changes.

To change the password the 'Change Password' setting in the 'System Config.' sub-menu should be edited. If an attempt is made to change the password the user will first be logged out and will have to log in again (to prove authenticity). After changing the setting the user will be asked to confirm the password by re-entering it.

If no password has been set, the text 'NOT ACTIVE' will be shown as the setting value of the 'Change Password' setting. If a password has been set the setting value will be shown as either a 7 or 8 digit number. If the password is forgotten, this 7 or 8 digit number can be communicated to Siemens Protection Devices Limited, by an authorised person and the password can be decoded.

If a password has been set it can be removed by entering the text 'NONE' into the 'Change Password' setting.

#### 2.1.1.2 Yes/No Confirmation

Some settings require further confirmation of change using Yes/No confirmation. When the confirmation screen appears the edit field will be flashing 'N' (for 'No'). Use the up (▲) or down (▼) key to change the field to 'Y' (for 'Yes') and then press **ENTER** to confirm the change. Pressing **CANCEL**, or pressing **ENTER** without changing the field to 'Y' will abort the change.

### 2.1.2 Instruments

While an instrument is being displayed it will be updated regularly.

#### 2.1.2.1 Default Instruments

When an instrument is being displayed, pressing **ENTER** toggles its "default instrument" status on and off.

A default instrument is one that is displayed automatically by the Argus after no keys have been pressed for a period. A number of default instruments can be set in which case they will be cycled in turn for 5 seconds each. The period before the default instruments are displayed is controlled by the 'Default Screen Time' setting in the 'System Config.' menu.

If an instrument is set as a default instrument this is indicated by a '□' in the top right corner of the display.

While a default instrument is being displayed, pressing any key (except **TEST/RESET**) will revert the display to that being displayed before the default instrument was activated.

#### 2.1.2.2 Resetting Counts

Some instruments show count or summation values, e.g. Trip Count, Sum of I<sup>2</sup>. These can be reset using settings within the relevant sub-menus. Pressing the **TEST/RESET** key while the appropriate instrument is displayed will also reset them. You will be asked to confirm this using a Yes/No confirmation (as described in section 2.1.1.2 but **TEST/RESET** can also be used to confirm, rather than pressing **ENTER**).

### 2.1.3 Fault Displays

As shown in Figure 2-1, the occurrence of a fault (as defined by the 'Fault Trigger' setting) will cause the red trip LED to be lit and the trip display will be shown. This gives the date (DD/MM) and time (HH:MM:SS) of fault and the poles that were active at the time of trip.

**Example: -**

12/05 17:25:51
TRIP A E

Pressing the **TEST/RESET** key will extinguish the trip LED, reset latched output relays and change the display to the scrolling fault display, giving a more detailed fault record. On the top line of this display the fault number (1 to 5) is displayed. The bottom line gives the date and time of trip (DD/MM/YY HH:MM:SS.ssss), the active group and then for each pole of the Argus relay:



- Current at time of trip
- The voltage at time of trip (certain Argus 2 models only)
- Forward or reverse direction of current flow (directional relays only)
- Elements which were active (above setting) at time of trip
- Elements that operated for the trip to occur are indicated by <...> around the element

**Example: -**

Fault 1 <<<fault data>>>
-----------------------------

where 'fault data' is: 25/02/01 17:25:51.2525 G1 PHASE A LS IDMTL <HS1> HS2 IA = 12.32xIn ...

This information scrolls along the bottom line of the display.

This record can be viewed again later in the Fault Data displays. The five most recent faults are stored, with the oldest being lost when a new fault occurs. The five faults are numbered from 1 to 5 with fault 1 being the most recent.

## 2.1.4 Software Information

The identity of the software present in the Argus can be displayed as follows:

Ensure that the 'Relay Identifier' is displayed on the LCD (if necessary press the **CANCEL** key until it shows). Press and hold the **CANCEL** key, then press the **TEST/RESET** key, then release the **CANCEL** key and **TEST/RESET** key together.

The software article numbers and revisions will now be displayed on the LCD. Press any key to return to the 'Relay Identifier'.

## 2.1.5 Operation with Front Cover Fitted

When the clear plastic cover is fitted only the down (▼) and right (▶)/**TEST/RESET** keys are accessible using through-cover buttons. These buttons are recessed to prevent inadvertent operation of the keys.

Referring to Figure 2-1, it can be seen that all areas of the menu can be accessed using the ▼ and ▶ keys but that settings cannot be changed since the **ENTER** key is not accessible. Counter instruments can be reset while viewing them by pressing **RESET**, then using ▼ and **RESET** to confirm.

## 2.2 Operation using Reydisp Evolution (IEC 60870-5-103 comms only)

Reydisp Evolution provides the means to achieve the following:

- Get (upload) a settings file from the Argus
- Download a settings file to the Argus
- Change individual settings
- Get the active group number
- Set the active group number
- Monitor for events and display them spontaneously
- Upload the complete events file from the Argus
- Clear the events file
- Upload waveform records from the Argus
- Trigger waveform recording
- Clear waveform records
- Continuously display instruments i.e. meters, counters, relay status, ARC status etc.
- Get system data (hardware and software details) from the relay
- Reset all flags
- Send commands to the relay. Allows user to access the command set of the Argus which includes synchronise the clock, change settings group, trip and close circuit breakers, enable and disable auto-reclose functions and protection elements

The Reydisp Evolution software can be used with all Argus and Modular II protection relays supplied by Siemens Protection Devices Limited.

Use of the Reydisp Evolution software is menu driven, with the settings, events, waveforms, instruments and commands all being available in separate menus.

The settings are displayed in the same order as on the relay fascia.

## Section 3: Installation

### 3.1 Unpacking, Storage and Handling

On receipt, remove the Argus from the container in which it was received and inspect it for obvious damage. It is recommended that the Argus relay not be removed from the case. To prevent the possible ingress of dirt, the sealed polythene bag should not be opened until the Argus is to be used.

If damage has been sustained, a claim should immediately be made against the carrier, also inform Siemens Protection Devices Limited.

When not required for immediate use, the Argus should be returned to its original carton and stored in a clean, dry place.

The Argus relay contains static sensitive devices. These devices are susceptible to damage due to static discharge and for this reason it is essential that the correct handling procedure is followed.

The Argus relay's electronic circuits are protected from damage by static discharge when it is housed in its case. When the relay has been withdrawn from the case static handling procedures should be observed as follows: -

- Before removing the Argus from its case the operator must first physically touch the case to ensure that he/she is at the same potential.
- The Argus relay must not be handled by any of the terminals on the rear of the chassis
- Argus relays must be packed for transport in an anti-static container
- Ensure that anyone else handling the Argus is at the same potential

As there are no user serviceable parts in the Argus relay, then there should be no requirement to remove any modules from the chassis. If any modules have been removed or tampered with, then the guarantee will be invalidated. Siemens Protection Devices Limited reserves the right to charge for any subsequent repairs.

### 3.2 Recommended Mounting Position

The Argus uses a liquid crystal display (LCD) which is used in programming and for operation. The LCD has a viewing angle of  $\pm 70^\circ$  and is back-lit. However, the best viewing position is at eye level and this is particularly important when using the built-in instrumentation features.

The LCD contrast will normally be correct for all positions and environments, however it can be adjusted if required using the adjustment screw mounted through the fascia to the upper right of the LCD.

The Argus relay should be mounted on the circuit breaker or panel to allow the operator the best access to the functions.

### 3.3 Relay Dimensions

The following drawings are available which give panel cut out and mounting details. Refer to the appropriate Diagrams and Parameters part of the documentation for a cross-reference of case sizes and models.

- 2995X10004 Overall Dimensions and Panel Drilling for Epsilon E4 Case
- 2995X10006 Overall Dimensions and Panel Drilling for Epsilon E6 Case
- 2995X10008 Overall Dimensions and Panel Drilling for Epsilon E8 Case

### 3.4 Wiring

The Argus should be wired according to the scheme requirements, with reference to the appropriate wiring diagram. Refer to the appropriate Diagrams and Parameters part of the documentation for a cross-reference of wiring diagrams and models.

#### 3.4.1 Communications

Fibre-optic ST<sup>TM</sup> (BFOC/2.5) bayonet connectors – 2 per Argus. Glass fibre is recommended for all but the shortest distances.

When installing fibre ensure that the fibre's bend radii comply with the recommended minimum for the fibre used – typically 50mm is acceptable for single fibres.

An option for RS485 electrical interface is available. A maximum of 256 devices can be connected using 120 ohm screened twisted pair wire ie Belden 3105A, or similar, terminated with a suitable flat blade or pin connector. The last device in the circuit must be terminated with the termination link as show in section P20008-Diagrams & Parameters, this connects the internal 120 ohm terminating resistor.

## 3.5 Fixings

### 3.5.1 Crimps

Davico ring tongue with 90 deg bend

**Table 3-1 Wire crimp sizes**

Wire Size	Davico
0.25 to 1.6 mm <sup>2</sup>	DVR1-4 (90deg)
1.0 to 2.6 mm <sup>2</sup>	DVR2-4 (90deg)

### 3.5.2 Panel Fixing Screws

Kit ZA0005-062 comprising of:

- Screw Pan Head M4x10mm (Black) ZB5364-101 2off
- Nut M4 2103F11040 2off
- Lock washer 2104F70040 2off

Two kits are required for the R4, R6 and R8 case sizes.

## 3.6 Ancillary Equipment

The Argus can be interrogated locally or remotely by making connection to the fibre optic terminals on the rear of the case. For local interrogation a portable PC with a fibre to RS232 modem is required. The PC must be capable of running Microsoft Windows 98 or greater, and it must have a standard RS232 port, a USB- RS232 adaptor, or a suitable PCMC1A RS232 adaptor can be used in order to drive the modem. The Reydisp communications package can then be used to interrogate the relay using the IEC 60870-5-103 protocol. For remote communications more specialised equipment is required see *Section 4: Communications Interface* in the *Technical Reference* section of this manual.

## Section 4: Commissioning

### 4.1 Before Testing

#### 4.1.1 Test Equipment

500V Insulation resistance test set.

1. Secondary injection current source rated 10A or greater
2. Time interval meter
3. Primary injection equipment
4. A d.c. supply with nominal voltage within the working range of the Argus d.c. auxiliary supply rating
5. A d.c. supply with nominal voltage within the working range of the Argus d.c. status input rating

Additionally for Argus 2 and 6 relays, the following equipment is required

Variable voltage source

6. Phase shifting transformer
7. Phase Sequence Indicator

Alternatively, items 1, 2, 4, 5, 6 and 7 can be replaced by a computer programmable V & I source universal test set

Additional equipment for general tests and for testing the communications channel:-

Portable PC with an RS232 to fibre-optic converter and suitable interface cable or via RS485 input. Printer to operate from the above PC (Optional).

#### Use of PC to Facilitate Testing

The functions of Reydisp Evolution (see section 2.2) can be used during the commissioning tests to assist with test procedures or to provide documentation recording the test and test parameters. One method is to clear both the waveform and event records before each test is started, then, after the tests, upload from the Argus the settings, events and waveform files generated as a result of application of the tests. These can then be saved off to retain a comprehensive record of all tests. This method is particularly useful when auto-reclose sequences are being checked.

When testing is completed then the event and waveform records should be cleared and the settings file checked to ensure that the required in-service settings are being applied.

#### 4.1.2 Precautions

Before electrical testing commences the equipment should be isolated from the current transformers and the CTs should be short-circuited in line with the local site procedures. The tripping and alarm circuits should also be isolated where practical. The provision and use of secondary injection test sockets on the panel simplifies the test procedure.

Ensure that the correct d.c. auxiliary supply voltage and polarity is applied. See the relevant scheme diagrams for the relay connections.

Check that the nominal secondary current rating of the current transformers has been correctly set on the P/F Rating, E/F Rating and SEF Rating settings in the System Config. menu of the relay.

#### 4.1.3 Applying Settings

The settings for the particular application should be applied before any secondary testing occurs. If they are not available then the Argus has default settings that can be used for pre-commissioning tests. Refer to the appropriate Diagrams and Parameters document for the default settings. Note that the tripping and alarm contacts must be programmed correctly before any scheme tests are carried out.

Argus relays feature eight alternative settings groups. In applications where more than one settings group is to be used then it may be necessary to test the Argus in more than one configuration.

**Note.** One group may be used as a 'Test' group to hold test-only settings that can be used for regular maintenance testing, eliminating the need for the Test Engineer to interfere with the actual in-service settings in the normally active group. This Test group may also be used for functional testing where it is necessary to disable or change settings to facilitate testing.

When using settings groups it is important to remember that the Argus need not necessarily be operating according to the settings that are currently being displayed. There is an 'Active Settings Group' on which the Argus operates and an 'Edit/View Group' which is visible on the display and which can be altered. This allows the settings in one group to be altered while the protection continues to operate on a different unaffected group. The 'Active Settings Group' and the 'Edit/View Group' are selected in the 'System Configuration Menu'.

Elsewhere in the settings menu system, those settings that can be altered for different groups are indicated by the symbols G1, G2 etc. in the top left of the display. All other settings are common to all groups.

## 4.2 Tests

### 4.2.1 Inspection

Ensure that all connections are tight and correct to the wiring diagram and the scheme diagram. Record any deviations. Check that the Argus is correctly programmed and that it is fully inserted into the case. Refer to Section 2: Operation Guide for information on programming the Argus.

### 4.2.2 Insulation Tests

Connect together all of the C.T. terminals and measure the insulation resistance between these terminals and all other terminals connected together and to earth.

Connect together the terminals of the DC auxiliary supply circuit and measure the insulation resistance between these terminals and all other terminals connected together and to earth.

Connect together the terminals of the DC status input circuits and measure the insulation resistance between these terminals and all other terminals connected together and to earth.

Connect together the terminals of the output relay circuits and measure the insulation resistance between these terminals and all other terminals connected together and to earth.

*Argus 2 and Argus 6 only:*

Connect together all of the V.T. terminals and measure the insulation resistance between these terminals and all other terminals connected together and to earth.

Satisfactory values for the various readings depend upon the amount of wiring concerned. Where considerable multi-core wiring is involved a reading of 2.5 to 3.0 megohms can be considered satisfactory. For short lengths of wiring higher values can be expected. A value of 1.0 megohm should not be considered satisfactory and should be investigated.

Remove temporary connections.

### 4.2.3 Secondary Injection Tests

Select the required configuration and settings for the application.

Note that the Argus may be connected as either a 1A or a 5A rated device. The user should check this before commencing secondary testing.

For all high current tests it must be ensured that the test equipment has the required rating and stability and that the Argus is not stressed beyond its thermal limit.

#### 4.2.3.1 IDMTL/DTL Characteristics

*Argus 2 and Argus 6 only:* If the Argus is to be employed for directional protection then all 'Directional Control' settings should be set to 'OFF' during the following tests.

##### **Pick-up and Drop-off**

This test checks the accuracy of the current setting for the main overcurrent characteristic. Note that SEF/REF poles are considered later.

Inject single phase current into one of the current inputs. Slowly increase the current until the I>Is LED (yellow) operates and record the pick-up current in Table 4-4. Reduce the current until the LED goes out and record this as the Drop-off level. Repeat this test for each pole.

Check that all measured Pick-up current levels are within  $105\% \pm 4\%$  of the applied setting. Check that the Drop-off levels are  $\geq 95\%$  of the measured Pick-up value.

**Note.** Depending upon the applied settings a TRIP could occur if the current is on for longer than the operating time. This may be undesirable while measuring Pick-up and Drop-off levels. The 'Fault Trigger' setting (in the data storage menu) can be used to disable tripping indication temporarily during this test, also the Low and High Set elements may need to be temporarily turned 'OFF' in order to prevent unwanted instantaneous operations.

### Timing

This test checks the accuracy of the main time delay characteristic (IDMTL/DTL). Select the current setting, characteristic type and time multiplier setting as required. Then inject current at multiples of the setting.

The correct output contact must be programmed for the phase fault and earth fault elements. A time interval meter must be connected to the correct terminals. The timer should be started by the source and stopped by the trip contacts. Each pole should be tested. A secondary injection timing test circuit is illustrated in Figure 4-3.

Table 4-1 shows theoretical values for each characteristic curve with a time multiplier of 1.0. Record the actual results in Table 4-5 and check that the measured times lie within  $\pm 5\%$  or  $\pm 30\text{ms}$  of nominal time.

**Table 4-1 IDMTL Timing Characteristic (Time in Seconds)**

Curve	2 xIs	5 xIs
NI	10.03	4.28
VI	13.50	3.38
EI	26.67	3.33
LTI	120.00	30.00
DTL	-	-

#### 4.2.3.2 Lowset and Highsets

Phase Fault poles can have up to two highsets and one lowset, also the Earth fault can have up to two highsets and one lowset. The following tests should be applied to each element in the scheme.

The low/high set under test should be programmed to operate an output contact, which can then be monitored to detect operation of the element.

*Argus 2 and Argus 6 only:* If the Argus is to be employed for directional protection then all 'Directional Control' settings should be set to 'OFF' during the following tests.

#### Pick-up and Drop-off

Programme the current setting for the low/high set characteristic to the required level and set its time delay to 0.00 sec. Inject a level of current below the setting and increase the current until the output contact operates. Record the Pick-up level for each pole in Table 4-6, Table 4-7 or Table 4-8 and confirm that in each case it occurs within  $\pm 5\%$  of the applied setting.

For high levels of current the thermal limit of the Argus must not be exceeded. Refer to the performance specification for the Argus, which defines the thermal limits. Manual testing runs the risk of exceeding the thermal limit. When manually testing a high setting it is not considered necessary to establish the exact pick-up level and the following procedure is recommended to ensure that the thermal limit is not exceeded:-

1. Switch on the test supply and quickly raise the current to just below 95% of the set value and then switch off the test supply immediately. Switch back on and then off in quick succession to prove non-operation. Do this five times with a delay between each test of about 10 seconds.

Test similarly at 105% of setting to prove operation. Switch off, reset the trip indication and then switch on and off five times quickly to prove operation for each injection.

If a computer test set is being used then the pick-up level and timing can be measured provided that the automatic test is set up to apply pulses of current to avoid exceeding the thermal limit.

### Timing

The operating time should be tested with a current of 5 times setting applied and with the required time delay set. Output contacts for the Low/Highsets must be programmed and a time interval meter connected to the correct terminals.

The timer should be started by the source and stopped by the Low/Highset contacts. Each phase should be tested.

Record the results in Table 4-9, Table 4-10 and Table 4-11 and confirm that the measured delays are within  $\pm 5\%$  of the set values.

### 4.2.3.3 SEF/REF

#### Pick-up and Drop-off

For Argus relays with the SEF/REF element fitted then the current setting should be checked for this pole. This can be achieved in the same manner as the IDMTL/DTL Characteristic Pick-up/Drop-off tests.

Record the results in Table 4-12. Confirm that the measured Pick-up level is within  $\pm 5\%$  of the set value and that Drop-off occurs at  $\geq 95\%$  of the measured Pick-up value.

#### Timing

The timers used in the SEF/REF mode are operated sequentially. Separate contacts must be configured for timer 1 and timer 2 in order that operation of each timer is checked.

Set the operating time on timer 1 to the required time and connect a time interval meter to the contact configured for timer 1. Inject a current at least three times the setting and record the time.

Set the operating time on timer 2 to the required time and connect a time interval meter to the contact configured for timer 2. Inject a current at least three times the setting and record the time. The operating time is the addition of time 1 and time 2. Subtract time 1 from time 1+2 to get the operating time for timer 2.

Note that the SEF/REF pole has an additional available timer that is referred to as the lowset delay, this should be tested if required by the application.

Record the results in Table 4-13 and confirm that the measured delays are within  $\pm 5\%$  of the set values.

### 4.2.3.4 Circuit Breaker Fail

To measure the pick up level, temporarily set a status input to operate the external CBF function then invert the input, this enables the element. The delay time should be set to zero. Inject current and record the pick up level in Table 4-14.

The 2-stage circuit breaker failure feature should be tested if required by the application. If only one of the stages is to be used then only CBF delay 1 need be tested.

In order to test both stages of the CBF feature then the two CBF delays should be programmed to operate separate output contacts other than the main trip output. They should also be programmed with their appropriate delays and current level setting.

CBF delay 1 is initiated by the main trip output and current above the setting, after timing out it generates a trip output of its own and also initiates the CBF delay 2 which subsequently generates a final trip output.

Connect the main trip output to start a time interval meter. Connect the output from CBF delay 1 to stop both the timer and the current source. Inject current of 2x setting into any pole and record the first CBF time delay in Table 4-15.

Connect the CBF delay 1 output to start the time interval meter. Connect the output from CBF delay 2 to stop both the timer and the current source. Inject current of 2x setting into any pole and record the second CBF time delay.

Check that the measured delays are within  $\pm 5\%$  of the set values.

### 4.2.3.5 Directional Tests

*This applies to Argus 2 and Argus 6 relays only*

The following tests deal specifically with directional functionality. Note that there are a number of variants of directional Argus relays with various combinations of directional and non-directional poles. These tests should only be applied to those poles that are directionalised.

Note also that the directional response for each characteristic (eg IDMTL, highset, etc) is programmable and may be selected as either Non-directional, Forward, Reverse or TRI-state depending on the requirements of the scheme. For the following tests the 'Directional Control' settings should be set to the required settings.

#### Directional Polarity Check

This test checks for correct polarity of the directional circuits.

In the Instruments menu display; indication is provided on the output states of the directional elements, i.e. whether they see forward current, reverse current or neither for each pole. This display is an aid to commissioning testing. If the Argus is allowed to trip during testing then this display will be interrupted and replaced by the fault data display screen. If this normal operation interferes with testing then temporarily change the 'Fault Trigger' setting so that no fault indication will be given if the Argus trips.

1. Check the direction of each pole in turn by connecting to the appropriate terminals. Table 4-2 shows the polarising quantity for each pole. Figure 4-4 shows a directional test circuit for one type of Argus 2.

**Table 4-2 Connections for Directional Polarity**

Overcurrent pole	Polarising voltage
Phase A	$V_{BC}$
Phase B	$V_{CA}$
Phase C	$V_{AB}$
Earth-fault	$3V_0$

2. Inject rated current and apply rated voltage at the CA (MTA) phase angle setting. Then, for each pole, monitor the directional display in the instrument menu and check that indication of forward current (FWD) is displayed.

3. Repeat all of the above with the current connections reversed. Indication should now be given of reverse (REV) current flow.

4. To check the direction of the earth fault element on the Argus AG2xx series or the AG2xx-5xx series when connected Ph-Ph, the  $3V_0$  must then be applied to the residual voltage input.

To check the direction of the earth fault element on the AG2xx-5xx series of relays when connected Ph-N remove the voltage from the phase under test, keeping the voltage healthy on the other two phases. Where only single phase equipment is available then reverse voltage must be applied to the phase under test.

For all of the above tests inject residual current at the MTA into the earth fault input to confirm correct directional operation.

### Boundary of Operation

The purpose of this test is to ensure that the operating angles are correct for the forward and reverse zones of each pole. Note that if a pole is programmed to operate in one direction only then only the angles for that operating zone need be checked. Check that the required directional settings have been correctly applied, including the characteristic angles.

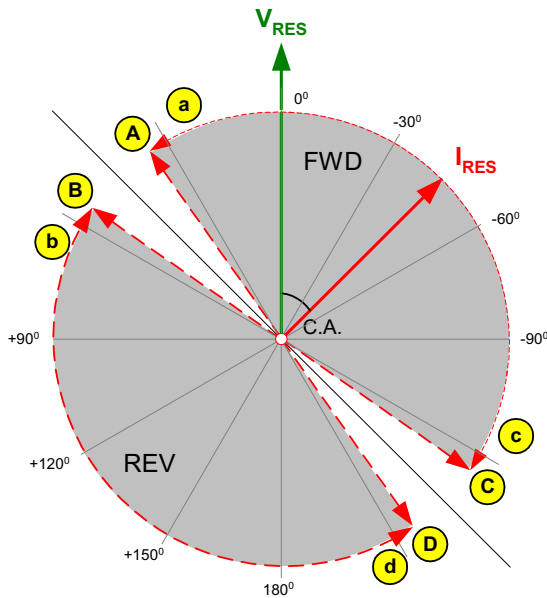
Each directional operate zone has two boundaries of operation, at leading and lagging boundaries of I with respect to V. To find the boundaries of operation for a particular pole, inject current and volts at the characteristic angle and check that 'FWD' is indicated. Then adjust the phase angle to find the lagging drop-off boundary (ie I lags V giving a negative angle), the 'FWD' indicator disappears at the drop-off angle. Set the angle back until the 'FWD' indicator reappears and adjust the phase angle to find the leading drop-off angle (positive angle).

To measure pick-up angles set the applied phase angle to be in the reverse zone and reduce the phase angle until 'FWD' is displayed. Do for both leading and lagging boundaries.

The reverse zone boundaries can be found in a similar fashion. Initially inject at the characteristic angle plus  $180^\circ$  and check that 'REV' is indicated. Then find the pick-up and drop-off angles at the leading and lagging boundaries.

Find the boundaries of the operate zones for each pole and record them in Table 4-16. If the test equipment is not accurate enough to measure the boundary then an all or nothing test could be applied to verify the correct direction indication.





Apply residual voltage either directly to input or by reducing voltage of faulted phase.

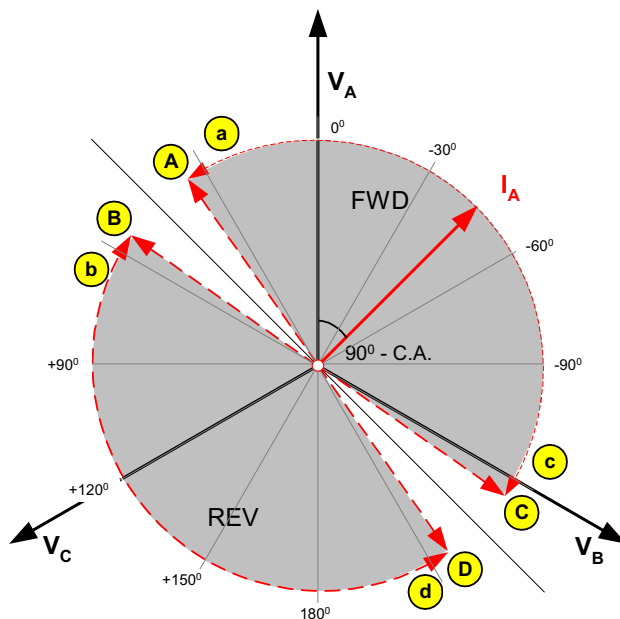
Adjust the phase angle of the residual current relative to the voltage:

Verify directional pick-up and drop off at points A, B, C and D

Alternatively,

Verify correct directional indication at points a, b, c and d (C.A +80°, +100°, -80°, -100°)

Figure 4-1 Directional Earth Fault Boundary System Angles



With balanced 3-phase system quantities:

Adjust the phase angle of the currents relative to the voltages:

Verify directional pick-up and drop off at points A, B, C and D

Alternatively,

Verify correct directional indication at points a, b, c and d (C.A +80°, +100°, -80°, -100°)

Figure 4-2 Directional Phase Fault Boundary System Angles

Table 4-3 Limits of Operate Pick-up Relay Angle Boundaries

Pole	CA	Direction	Operate (PU) limits (I wrt V)	
A,B,C	+45	forward lag	-37.5	-47.5
		forward lead	127.5	137.5
		reverse lead	-42.5	-52.5
		reverse lag	132.5	142.5
	+30	forward lag	-52.5	-62.5
		forward lead	112.5	122.5
E/F	-45	forward lag	-127.5	-137.5
		forward lead	37.5	47.5
		reverse lead	-132.5	-142.5
		reverse lag	42.5	52.5
	-65	forward lag	-147.5	-157.5
		forward lead	17.5	27.5

E/F		reverse lead	-57.5	-67.5
		reverse lag	117.5	127.5
	0	forward lag	-82.5	-92.5
		forward lead	82.5	92.5
		reverse lead	-87.5	-97.5
		reverse lag	87.5	97.5
	-15	forward lag	-97.5	-107.5
		forward lead	67.5	77.5
		reverse lead	-102.5	-112.5
		reverse lag	72.5	82.5

		reverse lead	-152.5	-162.5
		reverse lag	22.5	32.5
	-90	forward lag	-172.5	-182.5
		forward lead	-7.5	2.5
		reverse lead	-177.5	-187.5
		reverse lag	-2.5	7.5

### General Tests

Voltage sensitivity can be tested if required by injecting current of twice setting at the Characteristic Angle. The voltage should then be increased from zero until operation of the directional element is indicated. Operation should occur at less than 2V for phase fault and less than 3.3V for earth fault.

In Argus relays where the two-out-of-three gate function is available and is enabled then this feature can be checked. Provide a reference voltage  $V_{BC}$  and inject current at the characteristic angle into the A pole and check that no 'FWD' operation occurs. Repeat injecting 'FWD' operate currents into two poles simultaneously and the Argus should operate. (This test can be carried out as shown in Figure 4-5. A single phase voltage is applied across two inputs with the third in reverse, and a single phase current at characteristic angle is injected through all three poles in series. This applies one pole 'FWD' and the other two poles 'REV'; reverse the current direction to give two poles 'FWD' and one pole 'REV'.

Further tests may be required to check that the directional control settings have been correctly applied where these are complex. Similarly, if different threshold and delay settings have been applied for forward and reverse operation then these should be tested. Such additional tests should be specified according to the particular requirements of the scheme.

### 4.2.4 Auto Reclose Sequences

*These tests apply to Argus 4 and Argus 6 relays only*

The Auto Reclose sequences to be applied in-service should be set up and proved for each of the fault types. As detailed in section 4.1.1 it is suggested that a portable Personal Computer (PC), with Reydisp Evolution installed, be connected to the Argus via an RS232 to Fibre Optic Modem and Fibre optic cables. This will greatly facilitate the testing and documentation of the results of the various tests applied to the Scheme.

Reydisp Evolution can display the complete chronological event record generated by a full multi-shot Auto Reclose sequence for post test analysis (it is often difficult on site to keep track of protection and circuit breaker operations during a sequence test). The analysis function provided on the event record display enables the user to make time difference comparisons between two events. This allows, for example, accurate measurement of the Reclose delay (Dead time), or the Reclaim delay, without external equipment. The following information can be easily measured from a single Sequence event record: -

- Instantaneous Protection element operate times
- Circuit Breaker first Trip time
- Protection Starter element reset time
- Reclose (Dead Time) delay
- Circuit Breaker Close time
- Delayed Protection operate times
- Subsequent Circuit Breaker Trip and Close times
- Subsequent Reclose delays
- Reclaim delay
- Overall sequence time
- Status Interlock timing

Also the Waveform Record display for each trip enables time measurements to be made between the analogue waveforms and the digital (binary) traces of the Status inputs and output relays. Measurement of the relative timing of the a.c. current waveforms and the Circuit Breaker Status contacts provides valuable data on the condition of the Circuit Breaker operate times

In addition the Instruments provided by the Argus can be continuously monitored via Reydisp during a test sequence providing information on the state of the Argus and Circuit Breaker during a test sequence.

The sequence provided by the Argus in response to a permanent fault should be checked to ensure that the programmed sequence is as given for a Phase Fault and is also applicable to Earth Fault and/or Sensitive Earth Fault.

If the scheme requires the Argus to provide Auto Reclose initiated by a Status input then the SA Sequence should be checked. The response to a Transient fault should be checked.

Record the results of the sequence test in Table 4-17.

#### 4.2.5 Status Inputs

The operation of the status input(s) can be monitored on the 'Status Input' display shown in 'Instruments Mode'. Inject the required supply voltage into each status input and check for correct operation. Depending on the application, each status input may be programmed to perform a specific function; each status should be checked to prove that its mapping and functionality is as set.

Where the pick-up and/or drop-off timers associated with a status input are set to user scheme required delays these delays should be checked either as part of the scheme logic or individually. To check a status pick-up time delay, temporarily map the status to an output relay that has a normally open contact. Use an external timer and time the interval between status energisation and closure of the output contacts.

To measure the drop-off delay, map to an output relay that has a normally closed contact, time the interval between status de-energisation and closure of the output contacts.

**Note.** The time measured will include an additional delay, typically less than 20ms, due to the response time of the status input and the operate time of the output relay.

#### 4.2.6 Output Relays

A minimum of five output relays is provided. Three of these have change over contacts; the remainder have normally open contacts. Each contact can be tested individually by the trip test feature, which causes each output relay to be pulsed for the user-programmable minimum dwell time, or they can be checked during commissioning by testing the feature to which they are assigned.

**Note.** A quick method of energising an output relay permanently, so that wiring can be checked, is to temporarily map the output relay being tested to the 'Protection Healthy' signal – as this is permanently energised the mapped relay will be held energised and normally open contacts will be closed. Remember to deselect the output relays from the 'Protection Healthy' signal following the test.

#### 4.2.7 Primary Injection Tests

Primary injection tests are essential to check the ratio and polarity of the transformers as well as the secondary wiring.

##### 4.2.7.1 Primary Current Tests

Use the circuit shown in Figure 4-6 to check the current transformer ratio and the C.T. connections for phase to earth fault current. Inject a current of sufficient magnitude for the Argus relay ammeters to display. These levels should be compared with the ammeters connected in series with the Argus. The secondary current is:-

$$I_s = \frac{\text{Primary current}}{\text{CT ratio}}$$

Use the circuit shown in Figure 4-7 to check the current transformer ratio and the C.T. connections for phase to phase fault. Record the results in Table 4-18.

##### 4.2.7.2 Primary Directional Tests

*This applies to Argus 2 and Argus 6 relays only*

##### General

If the Argus being commissioned is directional then the voltage circuits should be tested to ensure correct polarity. It is recommended that the Argus be connected to the C.T.'s and V.T.'s with the polarity as shown in the Diagrams and Parameters section of this manual.

With the polarity connections shown, Argus relays will indicate 'FORWARD' direction of current when power is flowing away from the switchboard busbar and 'REVERSE' when flowing into the busbar.

For an outgoing feeder, 'FORWARD' is the normal direction of power flow and for an incoming circuit, 'FORWARD' is opposite to the normal direction of power. However, normal application of directional protection is

to initiate a trip when fault current flows away from the busbar. (For an incomer, this requires a parallel supply source).

In both cases therefore, the 'FORWARD' direction is the trip direction for normal applications.

Argus 2 and 6 protection elements can be programmed to trip either NON directional, FORWARD, REVERSE or both (TRI-STATE operation). The FWD and REV (TRI-STATE operation) settings can be user programmed independently to different sets of setting values.

### Phase Directional Element

Using a phase-sequence indicator, first check that the phase sequence of the voltages at the Argus are correct i.e. A-B-C and see by inspection that the phasing of the connections to the Argus is correct.

If system has reverse Phase rotation i.e. A-C-B this will affect the Phase Fault directional elements only.

For correct phasing of Type 1 Directional Relays i.e. AG2 – XXX series,

reverse  $V_{bc}$  i.e. connect voltage  $V_b$  to terminal 83 and  $V_c$  to terminal 82.

For correct phasing of Type 2 Directional Relays i.e. AG –5XX series,

connect as shown in figures 4 – 10 /11/12/13 for normal A-B-C rotation; no wiring changes are necessary as the required adjustment is performed internally by the Relay in response to the Phase rotation setting change given below.

change the rotation setting in [SystemConfig:Phase Rotation](#) from A-B-C to A-C-B.

Setting to A-C-B automatically changes 'Forward' to 'Reverse' and visa-versa.

Earth Fault connections remain unchanged, i.e. connections as shown.

Check the magnitudes of the voltage transformer voltages.

Pass a three phase load current of 20% or more of the current transformer rating in a known direction. From the 'Instruments Display Mode' check that the Argus correctly indicates either 'FORWARD' or 'REVERSE', in line with the direction of flow of the primary current.

If the flow of current is such that the Argus should operate, see that in fact it does operate. Note that it may be necessary to reduce the current setting to a level below the available three phase load current. Reverse the connections to the current coils and see that the Argus restrains.

If the flow of current is such that the Argus should restrain, see that in fact it does restrain, then reverse the connections to the current coils and see that it operates.

This test is based on the assumption that the load current has a normal power factor. If, however, the power factor is very low, leading or lagging, difficulties may be encountered. For example, a very low leading power factor with power in the forward direction may cause a quadrature connected protection to restrain.

When the test is complete all connections must be restored to normal. If any settings have been changed in proving the direction restore them to the original settings and repeat secondary injection testing as considered necessary.

### Earth Directional Element

If the application includes a directional earth element, polarised in the normal fashion from the open delta winding of a voltage transformer, then the following procedure should be followed:-

Disconnect the A phase primary input to the voltage transformer. Where primary fuses exist this can be done by removing the A phase fuse.

Short circuit the A phase main secondary winding. This should be done on the load side of the V.T. secondary circuit protection (eg fuse or miniature circuit breaker - MCB).

Short circuit and disconnect the current transformer secondary winding connections on the B and C phases.

Energise the circuit with primary load current (eg  $\geq 20\%$  of  $I_n$ ).

If the load power is flowing away from the busbars, then the directional earth fault element should indicate operation in the forward zone. Check that this is the case. Reverse the connections either to the current or voltage input and check for operation in the reverse zone.

If the load power is flowing toward the busbars, then the opposite results should be expected.

Finally, de-energise the circuit, restore normal connections, replace the A phase primary fuse and remove the shorting connections from the A phase V.T. and from the B and C phase C.T. connections.

Figure 4-8 shows the test set-up and the resultant applied voltages and currents for a simulated earth fault condition using load current.

### 4.3 Putting into Service

After tests have been performed satisfactorily the Argus should be put back into service as follows:-

Remove all test connections.

Where possible the Argus settings should be down loaded to a computer and a printout of the settings produced. This should then be compared against the required settings. It is important that the correct settings group is active if more than one group has been programmed.

Reset all event, waveform and fault records and reset all counters.

Replace all secondary circuit fuses and links, or close m.c.b's.

## 4.4 Commissioning Record Tables

These tables should be completed during commissioning as a record of the commissioning tests.

Relay Type \_\_\_\_\_ Serial Number \_\_\_\_\_  
 Substation \_\_\_\_\_ Feeder Identity \_\_\_\_\_  
 Tester \_\_\_\_\_ Date \_\_\_\_\_

### 4.4.1 Secondary Injection Tests

#### 4.4.1.1 Overcurrent

##### IDMTL/DTL Characteristic

**Table 4-4 Pick-up/Drop-off Results**

Pole	Pick-up setting	Measured pick-up	Pick-up error ( $\pm 4\%$ of 105%)	Measured drop-off	Drop-off error ( $\geq 95\%$ of pick-up)
Phase A					
Phase B					
Phase C					
E/F					

**Table 4-5 Timing Characteristic Results**

Pole	Characteristic (NI, VI, EI, LTI, DTL)	2x Is		5x Is	
		Delay	Error ( $\pm 5\%$ or $\pm 30$ ms)	Delay	Error ( $\pm 5\%$ or $\pm 30$ ms)
Phase A					
Phase B					
Phase C					
E/F					

#### Lowset and Highsets

**Table 4-6 Lowset setting results**

Pole	Lowset setting	Measured pick-up	Error ( $\pm 5\%$ of setting)
Phase A			
Phase B			
Phase C			
E/F			

**Table 4-7 Highset 1 setting results**

Pole	Highset 1 setting	Measured pick-up	Error (±5% of setting)
Phase A			
Phase B			
Phase C			
E/F			

**Table 4-8 Highset 2 setting results**

Pole	Highset 2 setting	Measured pick-up	Error (±5% of setting)
Phase A			
Phase B			
Phase C			
E/F			

**Table 4-9 Lowset timing results**

Pole	Lowset delay setting	Measured delay	Error (±5% or ±30 ms of setting)
Phase A			
Phase B			
Phase C			
E/F			

**Table 4-10 Highset 1 timing results**

Pole	Highset 1 delay setting	Measured delay	Error (±5% or ±30 ms of setting)
Phase A			
Phase B			
Phase C			
E/F			

**Table 4-11 Highset 2 timing results**

Pole	Highset 2 delay setting	Measured delay	Error (±5% or ±30 ms of setting)
Phase A			
Phase B			
Phase C			
E/F			

**SEF/REF****Table 4-12 Pick-up/Drop-off Results for SEF/REF**

Pole	Pick-up setting	Measured pick-up	Error (±5% of setting)	Measured drop-off	Error (≥95% of Pick-up)
SEF/REF					

**Table 4-13 SEF/REF Timing Results**

Delay	Delay setting	Measured delay	Error (±5% or ±30 ms of setting)
Timer 1			
Timer 1+2			
Timer 2			
Lowset			

**4.4.1.2 Circuit Breaker Fail****Table 4-14 Pick-up/Drop-off Results for CBF Level Detector**

Pole	Pick-up setting	Measured pick-up	Error (±5% of setting)	Measured drop-off	Error (≥95% of Pick-up)
Phase A					
Phase B					
Phase C					
E/F					

**Table 4-15 Circuit Breaker Fail Timing Results**

CBF delay	Delay setting	Measured delay	Error (±5% or ±30 ms of setting)
Delay 1			
Delay 2			



#### 4.4.1.3 Directional Tests

These tests apply to Argus 2 and Argus 6 relays only

**Table 4-16 Directional Boundaries of Operation**

Pole	CA (M.T.A.)	Forward				Reverse			
		Lag (point C)		Lead (point A)		Lag (point B)		Lead (point D)	
		Pick-up	Drop-off	Pick-up	Drop-off	Pick-up	Drop-off	Pick-up	Drop-off
A									
B									
C									
E/F									

#### 4.4.2 Autoreclose Sequences

These tests apply to Argus 4 and Argus 6 relays only

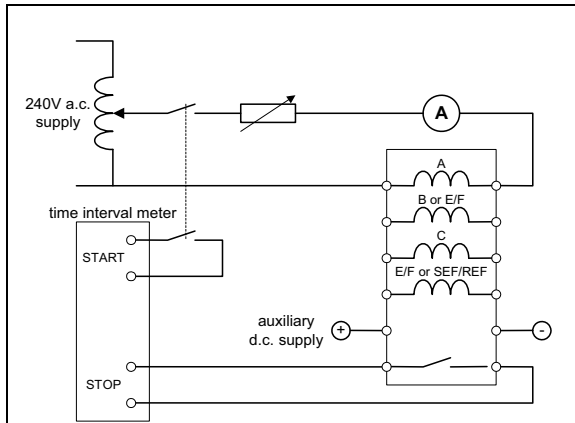
**Table 4-17 Auto-reclose Sequences and settings**

Sequence setting	Phase-fault	Earth-fault	SEF	Status
ARC IN/OUT				
Line Check trip				
Protection Trip 1				
Reclose delay 1				
Protection Trip 2				
Reclose delay 2				
Protection Trip 3				
Reclose delay 3				
Protection Trip 4				
Reclose delay 4				
Protection Trip 5	<b>Delayed</b>	<b>Delayed</b>	<b>Delayed</b>	
Shots to Lockout				
Highset 1 Trips to Lockout				
Highset 2 Trips to Lockout				
Transient fault				

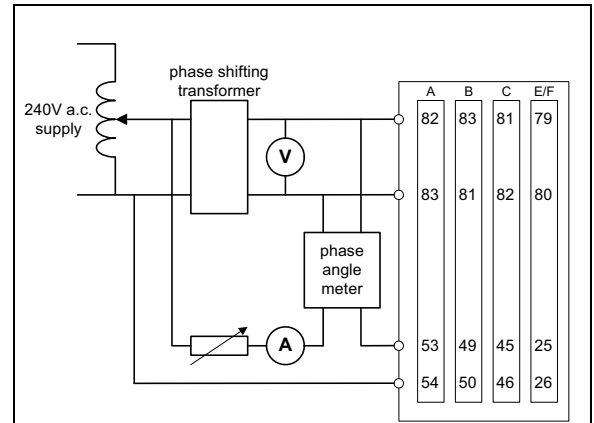
### 4.4.3 Primary Injection Tests

**Table 4-18 Primary Injection Results**

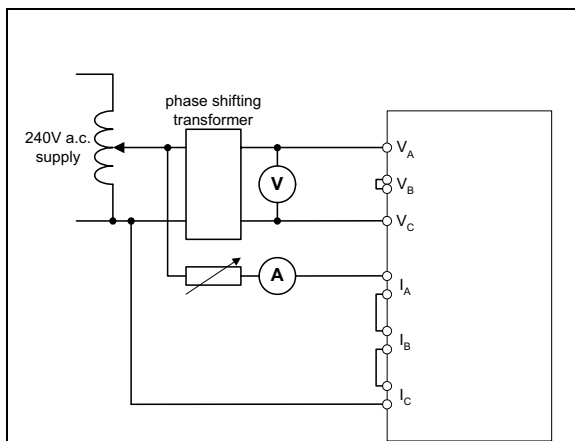
Phase injected	Primary current	Secondary current			
		A	B	C	E
A-B					
B-C					
B-E					



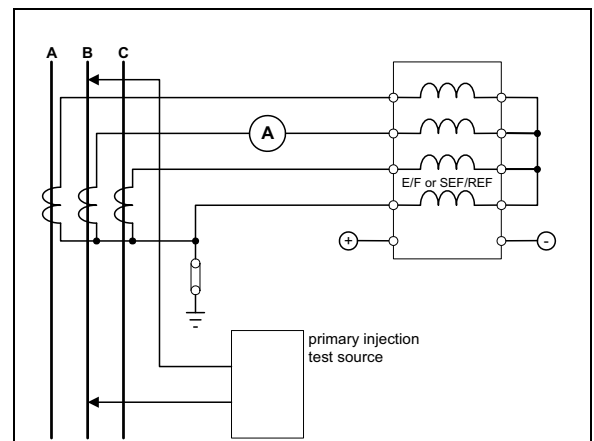
**Figure 4-3 Secondary Injection Test Circuit**



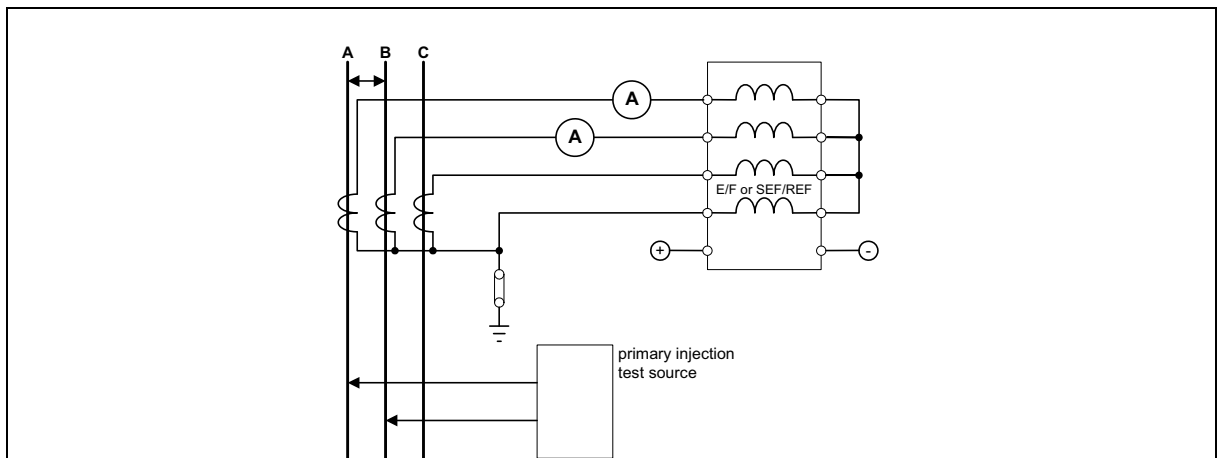
**Figure 4-4 Directional Test Circuit**



**Figure 4-5 Two-out-of-three Directional Test Circuit**



**Figure 4-6 Phase to Earth Primary Injection Test Circuit**



**Figure 4-7 Phase to Phase Primary Injection Test Circuit**

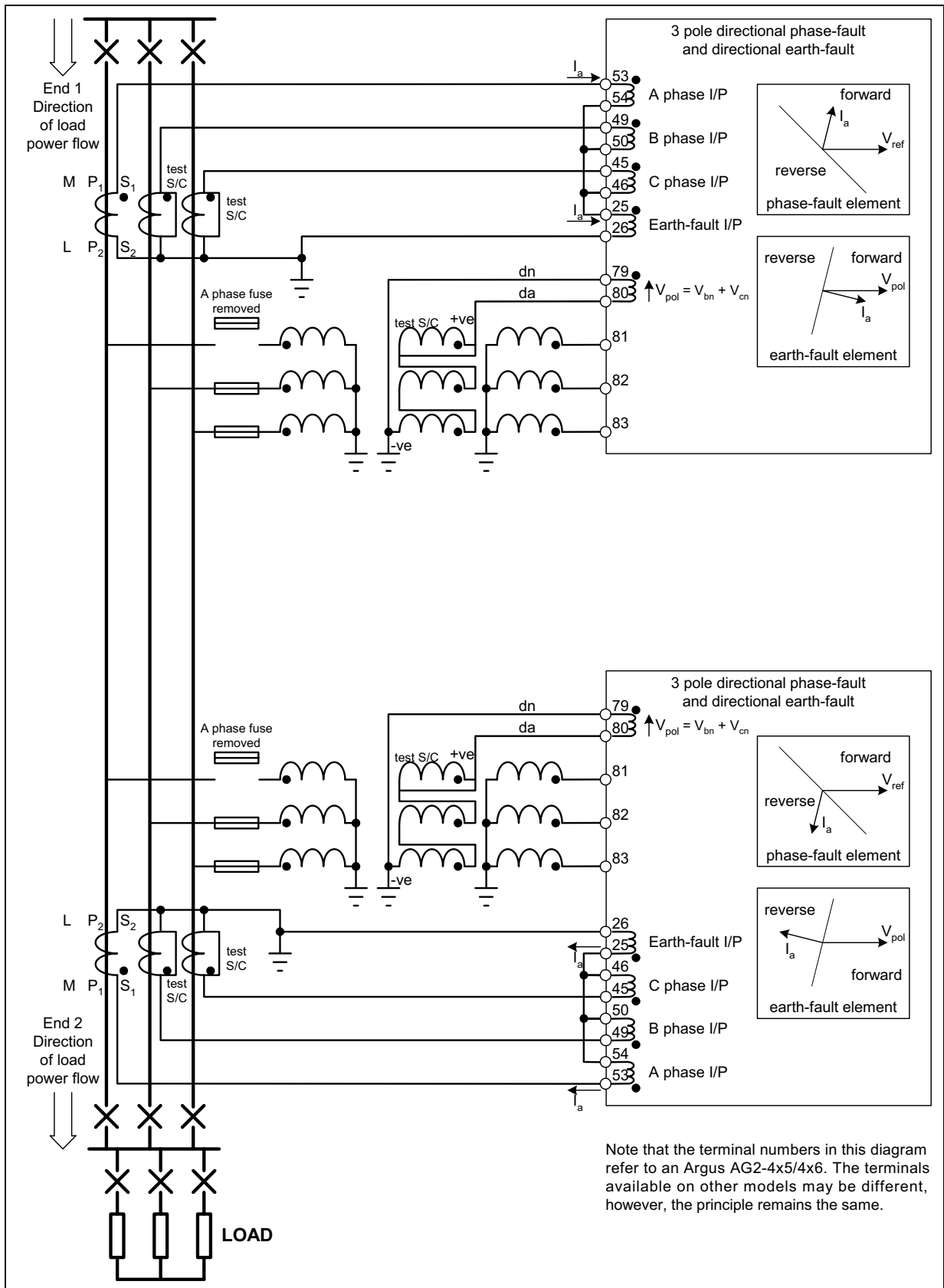


Figure 4-8 Resultant Applied Voltages and Currents for a Simulated Earth Fault Condition using Load Current

## Section 5: Testing and Maintenance

Argus relays are maintenance free, with no user serviceable parts.

### 5.1 Periodic Tests

During the life of the Argus, it should be checked for operation during the normal maintenance period for the site on which the product is installed. It is recommended the following checks/tests are carried out:-

1. Visual inspection of the metering display
2. Operation of output contacts
3. Secondary injection of each element

### 5.2 Maintenance

Failure of the Argus will be indicated by the 'Protection Healthy' LED being off or flashing. A message may also be displayed on the LCD. In the event of failure Siemens Protection Devices Limited. (or one of its agents) should be contacted – see defect report sheet in section 0.

If removal of the Argus from its case is required, the procedure described in section 3.1 should be followed.

### 5.3 Troubleshooting

Table 5-1 Troubleshooting Guide

Observation	Action
Relay does not power up.	Check that the correct auxiliary DC voltage is applied and that the polarity is correct.
Relay won't accept the password.	<p>The Password being entered is wrong. Enter correct password.</p> <p>If correct password has been forgotten, note down the Numeric Code which is displayed at the Change Password screen e.g.</p> <div style="border: 1px solid black; padding: 5px; width: fit-content; margin: 10px auto;"> <p style="text-align: center;">Change password = 1234567</p> </div> <p>To retrieve the password communicate this code to a Siemens Protection Devices Limited</p>
Protection Healthy LED flashes	General failure. Contact Siemens Protection Devices Limited.
LCD screen flashes continuously.	<p>The LCD has many possible error messages which when displayed will flash continuously. These indicate various processor card faults.</p> <p>General failure. Contact Siemens Protection Devices Limited.</p>
Backlight is on but no text can be seen.	Adjust the contrast.
Scrolling text messages are unreadable.	Adjust the contrast.
Relay displays one instrument after another with no user intervention.	<p>Default instruments are enabled. Remove all instruments from the default list and only add those which are required.</p> <div style="border: 1px solid black; padding: 5px; width: fit-content; margin: 10px auto;"> <p style="text-align: center;">A= 120A B= 123A <input type="checkbox"/> C= 108A E= 5A</p> </div> <p>The '☐' indicates that the instrument is a default instrument. Press ENTER to deselect it.</p> <p>(See section 2.1.2.1 Default Instruments).</p>
The LCD is stuck at the 'General Alarms' screen and is displaying 'Trip Circuit Failure Sx'. (x = 1...5)	The trip circuit failure feature is enabled and is expecting a healthy status input signal. Energise the correct Status Input, or disable the trip circuit feature if it is not required.

Observation	Action
Cannot communicate with the relay.	<p>Check that all of the communications settings match those used by Reydisp Evolution. E.g. Protocol set to IEC 60870-5-103</p> <p>Check that the Tx and Rx fibre-optic cables are connected correctly.</p> <p>( Tx → Rx and Rx → Tx ).</p> <p>Check that all cables, modems and fibre-optic cables work correctly.</p> <p>Set the line idle setting to Light On. Examine the Tx port on the back of the relay, with the fibre removed, and check that it is glowing red. If it is not then the communications board on the case may not be aligned correctly with the processor card socket.</p> <p>Contact a VA TECH representative.</p> <p>(WARNING : DO NOT LOOK AT THE FIBRE-OPTIC TRANSMITTER FOR A PROLONGED TIME).</p>
Relays will not communicate in a ring network.	<p>Check that the Data Echo setting on all relays is set to ON.</p> <p>Check that all relays are powered up.</p> <p>Check that all relays have unique addresses.</p>
Status inputs do not work.	<p>Check that the correct DC voltage is applied and that the polarity is correct.</p> <p>Check that the status input settings such as the Pick-up and Drop-off timers and the status inversion function are correctly set.</p>
Relay instrument displays show small currents or voltages even though the system is dead.	<p>This is normal. The relay is displaying calculation noise. This will not affect any accuracy claims for the relay.</p>

If the above checklist does not help in correcting the problem please contact Siemens Protection Devices Limited

## DEFECT REPORT

Please copy this sheet and use it to report any defect that may occur.

Customers Name & Address:			Contact Name:		
			Telephone No:		
			Fax No:		
Supplied by:			Date when installed:		
Site:			Circuit:		
Software Version:		Article No:		Report Required: Y/N	
Date Found:	During Commissioning:	During Maintenance:	From a System Fault:	Other, please state:	
Product Name:			Serial No:		
Copy any message displayed by the relay:					
Describe Defect:					
Describe any other action taken:					
Signature:		Please print name:		Date:	
For Siemens Protection Devices Limited use only:					
Date Received:	Contact Name:	Reference No:	Date Acknowledged:	Date of Reply:	Date Cleared:

To report a problem, please return this completed form to:

Siemens Protection Devices Limited  
 PO Box 8, Hebburn, Tyne & Wear, NE31 1TZ. England.  
 Telephone: +44 (0)191 401 7901  
 Fax: +44 (0)191 401 5575

# 7SG11Argus

Overcurrent Protection Relays

## Document Release History

This document is issue 2010/02 The list of revisions up to and including this issue is:

Pre release

2010/02	Document reformat due to rebrand
2008/11	Sixth issue: Instrumentation claims updated.
2007/02	Fifth issue: Thermal withstand and O/C operate claims updated to new std.
2006/03	Fourth issue: O/C Element reset levels updated
2006/03	Third issue: Editorial modifications, software revision histories updated.
2004/05	Second issue: Modification of CBF feature, DTL timers extended, CT Failure added, Auto Reclose sequence settings modified. Modbus protocol included and additional metering included.
2002/12	First issue

## Software Revision History


--	--	--

The copyright and other intellectual property rights in this document, and in any model or article produced from it (and including any registered or unregistered design rights) are the property of Siemens Protection Devices Limited. No part of this document shall be reproduced or modified or stored in another form, in any data retrieval system, without the permission of Siemens Protection Devices Limited, nor shall any model or article be reproduced from this document unless Siemens Protection Devices Limited consent.

While the information and guidance given in this document is believed to be correct, no liability shall be accepted for any loss or damage caused by any error or omission, whether such error or omission is the result of negligence or any other cause. Any and all such liability is disclaimed.



# Contents

<b>Section 1: Performance Specification</b> .....	<b>6</b>
1.1 General.....	6
1.1.1  Conformity.....	6
1.1.2 Reference.....	6
1.1.3 Dimensions and Weights.....	6
1.2 Energising Quantities.....	7
1.2.1 Characteristic Energising Quantities.....	7
1.2.2 Auxiliary Energising Quantity.....	8
1.3 Output Contacts.....	9
1.4 Functional Performance.....	9
1.4.1 Phase-fault Overcurrent Protection.....	9
1.4.2 Earth-fault Overcurrent Protection.....	11
1.4.3 Sensitive/Restricted Earth-fault Protection.....	11
1.4.4 Directional Characteristics.....	11
1.4.5 Circuit Breaker Fail.....	12
1.4.6 Auto-reclose.....	13
1.4.7 Instrumentation.....	13
1.4.8 Communication Interface.....	13
1.4.9 Real Time Clock.....	13
1.5 Environmental Performance.....	13
1.5.1 General.....	13
1.5.2 Immunity.....	14
1.5.3 Emissions.....	15
1.5.4 Mechanical.....	15
<b>Section 2: Functional Description</b> .....	<b>20</b>
2.1 Introduction.....	20
2.1.1 Models.....	21
2.1.2 Document Organisation.....	21
2.2 Configuration.....	22
2.2.1 Settings Groups.....	22
2.2.2 System Frequency.....	22
2.2.3 Current and Voltage Inputs.....	23
2.2.4 Identifier.....	24
2.2.5 General Alarms.....	24
2.2.6 Direction Tags.....	24
2.2.7 Real Time Clock.....	25
2.2.8 Default Instruments.....	25
2.2.9 Password.....	25
2.3 Phase-fault and Earth-fault Overcurrent.....	26
2.3.1 Delay Characteristic element.....	26
2.3.2 Instantaneous elements.....	27
2.3.3 Flashing (Pecking) Fault Protection.....	29
2.4 Sensitive Earth-fault and Restricted Earth-fault.....	30
2.4.1 High Impedance Restricted Earth-fault Scheme.....	31
2.5 Primary Equipment Fail Protection.....	31
2.5.1 Circuit Breaker (Trip) Fail Protection.....	31
2.5.2 Close Fail.....	32
2.5.3 Current Transformer Failure.....	32
2.5.4 Trip Circuit Supervision - for details see sections 2.10 and 3.8.....	33
2.6 Cold Load Protection.....	33
2.7 Directional Control.....	34
2.7.1 Polarisation.....	34
2.7.2 Two-out-of-three Gate.....	35
2.7.3 Voltage Memory.....	35
2.8 Voltage Protection.....	36
2.9 Auto-Reclose.....	37
2.9.1 Auto Reclose Sequences.....	38
2.9.2 Control Inputs.....	43
2.9.3 Frequent Operations Counter.....	44

2.9.4	Hot (Live) Line Working.....	44
2.10	Trip Circuit Supervision.....	45
2.11	Status inputs and Relay Outputs.....	45
2.12	Communications.....	47
2.13	Data Storage.....	47
2.13.1	Event Storage.....	47
2.13.2	Fault Data Record.....	47
2.13.3	Waveform (Disturbance) Records.....	48
2.13.4	Maximum Demand Function.....	49
2.14	Maintenance.....	50
2.14.1	Circuit Breaker Operations.....	50
2.14.2	Output Relay Test.....	51
2.14.3	Internal Supervision.....	52
2.15	Linesman Mode.....	52
<b>Section 3:</b>	<b>Application Notes.....</b>	<b>54</b>
3.1	Selection of Characteristics.....	54
3.1.1	Reset Delay.....	54
3.2	Directional Protection.....	54
3.2.1	Parallel or Ring Feeder Protection.....	54
3.3	Sensitive Earth-fault Protection.....	55
3.4	Blocking Schemes.....	56
Busbar Zone Protection.....	57	
3.5	High Impedance Restricted Earth-fault Protection.....	58
3.6	Circuit Breaker Fail Protection.....	60
3.7	Auto-reclose Applications.....	60
3.7.1	Reclose Time Setting.....	60
3.7.2	Reclaim Time Setting.....	60
3.7.3	Shots to Lockout Setting.....	61
3.7.4	Sequence Auto-reclosing.....	61
3.8	Trip Circuit Supervision.....	61
3.9	Output Relays.....	62
3.10	Post-fault Analysis.....	62
3.10.1	Events, Fault and Waveform Records.....	62
3.10.2	Fault triggers.....	62
3.10.3	Waveform triggers.....	63
3.10.4	ReyDisp (IEC 60870-5-103).....	63
<b>Section 4:</b>	<b>Communication Interface.....</b>	<b>64</b>
4.1	Introduction.....	64
4.1.1	Comms Protocol Setting.....	64
4.2	IEC 60870-5-103.....	64
4.2.1	Physical Connection.....	64
4.2.2	Medium.....	64
4.2.3	Recommended cable.....	64
4.2.4	Network Topology.....	65
4.2.5	Settings.....	65
4.2.6	IEC Class II Measurands.....	65
4.2.7	IEC Class II Update period.....	65
4.2.8	IEC Class II scaling.....	65
4.2.9	Baud Rate.....	65
4.2.10	Comms Parity.....	65
4.2.11	Relay Address.....	65
4.2.12	Line Idle.....	65
4.2.13	Data Echo.....	66
4.2.14	Modems.....	66
4.2.15	Connecting a Modem to the Relay(s).....	66
4.2.16	Setting the Remote Modem.....	66
4.2.17	Connecting to the Remote Modem.....	67
4.3	Introduction – Modbus RTU.....	68
4.3.1	Medium.....	68
4.3.2	Recommended cable.....	68
4.3.3	Network Topology.....	68

4.3.4	Settings .....	69
4.3.5	Comms Protocol .....	69
4.3.6	Baud Rate .....	69
4.3.7	Comms Parity .....	69
4.3.8	Relay Address .....	69
4.3.9	Line Idle .....	69
4.3.10	Data Echo .....	69
4.3.11	Glossary .....	70

## List of Figures

Figure 1.5-1	IDMTL Curves (Time Multiplier=1).....	16
Figure 1.5-2	Overcurrent Starter Operate Time to Contact .....	17
Figure 1.5-3	Instantaneous Highset Operate Time to Contact .....	17
Figure 1.5-4	Instantaneous Lowset Operate Time to Contact .....	17
Figure 1.5-5	Sensitive Earth-fault Frequency Response (Is = 5 mA) .....	18
Figure 1.5-6	Sensitive Earth-fault Operate Time to Contact .....	18
Figure 1.5-7	Directional Timing Characteristic .....	19
Figure 2.1-1	Overview of Argus Relay Protection Functions .....	20
Figure 2.3-1	Functional Diagram – Characteristic Phase-fault Overcurrent Element.....	27
Figure 2.3-2	Functional Diagram – Characteristic Earth-fault Overcurrent Element .....	27
Figure 2.3-3	Functional Diagram – Instantaneous Phase-fault Overcurrent Elements .....	28
Figure 2.3-4	Functional Diagram – Instantaneous Earth-fault Overcurrent Elements .....	28
Figure 2.4-1	Functional Diagram – Sensitive Earth-fault/Restricted Earth-fault Elements .....	30
Figure 2.5-1	Functional Diagram – Circuit Breaker Fail .....	32
Figure 2.5-2	Functional Diagram – Current Transformer Fail .....	33
Figure 2.7-1	Functional Diagram – Phase-fault Directional Element .....	35
Figure 2.7-2	Functional Diagram – Earth-fault Directional Element.....	35
Figure 2.8-1	Functional Diagram – Undervoltage/Overvoltage Element .....	37
Figure 2.11-1	Status Input Logic .....	46
Figure 2.11-2	Output Relay Logic.....	46
Figure 3.2-1	Parallel Feeder Protection .....	55
Figure 3.4-1	Blocking scheme giving fast fault clearance .....	56
Figure 3.4-2	Busbar Zone Protection with Circuit Breaker Fail using Non-directional Relays. For use on Single-source Feed Networks .....	57
Figure 3.4-3	Busbar Zone Protection with Circuit Breaker Fail Employing Bi-Directional relays. For use on fully Interconnected Networks with Remote Supply Sources.....	58
Figure 3.5-1	Balanced and Restricted Earth-fault protection of Transformers .....	59
Figure 3.5-2	Restricted Earth-fault Secondary Circuit.....	59
Figure 3.5-3	Composite Overcurrent and Restricted Earth-fault Protection .....	59
Figure 3.8-1	Engineering Recommendations S.15 H6 Trip Circuit Supervision scheme .....	61
Figure 3.8-2	Engineering Recommendations S.15 H5 Trip Circuit Supervision scheme .....	62
Figure 4.2-1	Communication to Argus Relay using Sigma 4 (Local Connection).....	67
Figure 4.2-2	Communication to Argus Relay using Sigma 4 and Modem .....	67
Figure 4.2-3	Communication to Multiple Argus Relays from Control System and Laptop with Sigma 3 and Fibre-optic Ring Network .....	67
Figure 4.2-4	Communication to Multiple Argus Relays from Control System and Laptop with Sigma 1 and Fibre-optic Star Network .....	68
Figure 4.3-1	Communication to Argus Relay using Sigma 4 (Local Connection).....	69
Figure 4.3-2	Communication to Multiple Argus Relays from Control System and Laptop with Sigma 1 and Fibre-optic Star Network .....	70
Figure 4.3-3	Communication to Argus Relay using RS485 – RS232 converter (Local Connection).....	70
Figure 4.3-4	Communication to Argus Relay using RS485/RS232 converter (Multidrop Connection).....	70

## List of Tables

Table 2-1	Overview of Functional Description Sections .....	21
Table 2-2	Settings Group Settings.....	22

Table 2-3	System Frequency Setting .....	23
Table 2-4	Current and Voltage Input Settings .....	23
Table 2-5	Identifier Setting .....	24
Table 2-6	General Alarm Settings .....	24
Table 2-7	Direction Settings .....	25
Table 2-8	Real Time Clock Settings .....	25
Table 2-9	Default Instrument Setting .....	25
Table 2-10	Password Setting .....	26
Table 2-11	Phase-fault and Earth-fault Overcurrent Settings .....	28
Table 2-12	Flashing Fault Setting.....	29
Table 2-13	Sensitive Earth-fault / Restricted Earth-fault Settings .....	30
Table 2-14	Circuit Breaker Fail Settings .....	32
Table 2-15	Current Transformer Fail Settings .....	33
Table 2-16	Cold Load Pickup Settings .....	34
Table 2-17	Directional Settings .....	35
Table 2-18	Voltage Protection Settings .....	37
Table 2-19	Auto-reclose from Internal Elements - Settings .....	40
Table 2-20	Auto-reclose from External Trip Settings .....	42
Table 2-21	Auto-reclose Commands Settings .....	44
Table 2-22	Live Line Working Setting .....	45
Table 2-23	Trip Circuit Supervision Settings .....	45
Table 2-24	General Output Relay and Status Input Settings .....	46
Table 2-25	List of Entries for Fault Data Records.....	47
Table 2-26	Data Storage Settings .....	49
Table 2-27	Circuit Breaker Maintenance Settings .....	51
Table 2-28	Output Relay Test Setting .....	51
Table 2-29	Internal Supervision Setting.....	52
Table 2-30	Linesman Mode Setting.....	53
Table 2-31	Linesman Mode Settings and Commands.....	53
Table 4-1	Communications Settings.....	66
Table 4-2	Communications Settings.....	69

## Section 1: Performance Specification

### 1.1 General

#### 1.1.1 CE Conformity

This product is CE compliant to the following applicable EU directives.

Electromagnetic Compatibility Directive

CE 89/336/EEC

Compliance to the European Commission Directive on EMC is claimed via testing to the Harmonised Product Standard:- EN 50263:2000

Low voltage Directive

CE 73/23/EEC

Compliance to the European Commission Directive on LVD is claimed via testing to the Harmonised Product Standard:- EN 60255-5:2000

#### 1.1.2 Reference

These products comply with the requirements of the IEC 60255-xx series and IEC 60068 standards and specifically with IEC 60255-3 and IEC 60255-12.

##### 1.1.2.1 Accuracy Reference Conditions

This product has been tested under the following conditions, unless specifically stated otherwise.

Parameter	Value	
Current settings	100 % $I_n$	
Time multiplier	1.0	
Current input	IDMTL	2 to 30 $xI_s$
	DTL	5 $xI_s$
Voltage input	110 V	
Auxiliary supply	nominal	
Frequency	nominal	
Ambient temperature	20 °C	

#### 1.1.3 Dimensions and Weights

##### Dimensions

Parameter	Value	
Width	E4 case	103 mm
	E6 case	155 mm
	E8 case	206 mm
Height	177 mm	
Depth behind panel (including clearance for wiring)	237 mm	
Projection (from front of panel)	32 mm	

See appropriate case outline and panel drilling drawing, as specified in Diagrams and Parameters document, for complete dimensional specifications.

### Weights

Parameter	Value	
Net weight	Argus 1, E4 case	3.3 kg
	Argus 1, E6 case	4.8 kg
	Argus 2, E4 case	3.3 kg
	Argus 2, E8 case	6.6 kg
	Argus 4, E6 case	4.8 kg
	Argus 6, E8 case	6.6 kg

## 1.2 Energising Quantities

### 1.2.1 Characteristic Energising Quantities

Parameter	Value
Nominal frequency	50, 60 Hz

#### 1.2.1.1 AC Current

#### Nominal Current and Measuring Range

	Nominal	Measuring Range	
$I_n$	1, 5 A	Phase and earth	$80 \times I_n$
		SEF/REF	$2 \times I_n$

Note. 1 A and 5 A nominal inputs are user selectable on each model.

#### Thermal Withstand

Overload Period	Overload Current			
	Phase and earth		SEF/REF	
	1A	5A	1A	5A
continuous	$3.0 \times I_n$		$2.0 \times I_n$	
10 minutes	$3.5 \times I_n$			
5 minutes	$4.0 \times I_n$			
3 minutes	$5.0 \times I_n$			
2 minutes	$6.0 \times I_n$			
3 seconds	57.7 A	202 A	37.5 A	202 A
2 seconds	70.7 A	247 A	46 A	247 A
1 second	100 A	350 A	65 A	350 A
1 cycle	177 A	618 A	115 A	618 A

#### Burden

Attribute	Value			
	Phase and earth		SEF/REF	
	1A	5A	1A	5A
AC Burden	$\leq 0.05 \text{ VA}$	$\leq 0.2 \text{ VA}$	$\leq 0.2 \text{ VA}$	$\leq 0.4 \text{ VA}$
Impedance	$\leq 0.05 \ \Omega$	$\leq 0.01 \ \Omega$	$\leq 0.2 \ \Omega$	$\leq 0.02 \ \Omega$

## 1.2.1.2 AC Voltage

Argus 2 and Argus 6 relays only

**Nominal Voltage and Range**

	Nominal	Operating Range
$V_n$	110 V	250 V continuous

**Burden**

	Attribute	Value
	AC Burden	< 0.1 VA at 110 V

## 1.2.2 Auxiliary Energising Quantity

**Auxiliary Power Supply**

	Nominal	Operating Range
$V_{AUX}$	24, 30, 48 V	18 to 60 VDC
	110, 220 V	88 to 280 VDC 100 to 130 VAC

**Burden**

	Attribute	Value	
	DC Burden	Quiescent (typical)	3 W
		Maximum	10 W

**Status (Digital) Inputs**

	Nominal	Operating Range
$V_{ST}$	30, 34 V	18 to 37.5 VDC
	48, 54 V	37.5 to 60 VDC
	110, 125	87.5 to 137.5 VDC
	220, 250	175 to 280 VDC

When relays with 48/54V status inputs are supplied for 110/125 V or 220/250 V working, external dropper resistors will be supplied listed in the table below. This will enable the status input performance specified below for the 48/54V status inputs to be achieved on 110/125 V or 220/250 V.

Nominal Operating Voltage	Resistor Value; Rating
110, 125 V	2K7 $\pm$ 5 %; 2.5 W
220, 250 V	8K2 $\pm$ 5 %; 6.0 W

**Performance**

Attribute	Value	
Minimum DC current for operation	$V_{ST} = 30 - 54 \text{ V}$	10 mA
	$V_{ST} = 110 - 250 \text{ V}$	< 5 mA
Reset/Operate voltage ratio	$\geq 90 \%$	
Typical response time	5 ms (10ms for ARGUS 2 type II)	
Typical response time when programmed to energise an output relay contact	< 15 ms	
Recommended Minimum pulse duration	40 ms with setting of 20ms PU delay for a.c. rejection	

Each status input has associated timers which can be programmed to give time delayed pick-up and time delayed drop-off. These timers have default settings of 20ms, thus providing rejection and immunity to an AC input signal.

Status inputs will not respond to the following:-

- 250V RMS 50/60Hz applied for two seconds through a 0.1 $\mu$ F capacitor.
- Discharge of a 10 $\mu$ F capacitor charged to maximum DC auxiliary supply voltage.

The status inputs with nominal voltage of 30 V to 54 V meet the requirements of ESI 48-4 ESI 1.

### Low Burden Status Inputs

Optionally, low burden status inputs are available directly rated for 110/125Vd.c. or 220/250Vd.c. without dropper resistors. These inputs do not meet the ESI 48-4 ESI 1 requirements. Where necessary a single external dropper resistor in parallel can be fitted to meet ESI 48-4 ESI 1 requirements.

### Low Burden Status Input performance

	Nominal	Operating Range	Typical burden
	110, 125	87.5 to 137.5 V DC	1.75 mA to 3.0 mA
	220, 250	175 to 280 V DC	1.75 mA to 3.0 mA

110/125 V minimum pick-up voltage typically 50 – 60 V d.c.

220/250 V minimum pick-up voltage typically 100 – 120 V d.c.

## 1.3 Output Contacts

Contact rating to IEC 60255-0-20

Attribute		Value
Carry continuously		5 A AC or DC
Make and carry (L/R ≤ 40 ms and V ≤ 300 V)	for 0.5 s	20 A AC or DC
	for 0.2 s	30 A AC or DC
Break (≤ 5 A and ≤ 300 V)	AC resistive	1250 VA
	AC inductive	250 VA at p.f. ≤ 0.4
	DC resistive	75 W
	DC inductive	30 W at L/R ≤ 40ms 50 W at L/R ≤ 10ms
Minimum number of operations		1000 at maximum load
Minimum recommended load		0.5 W at minimum of 10mA or 5V

## 1.4 Functional Performance

### 1.4.1 Phase-fault Overcurrent Protection

A time-delayed characteristic (IDMTL, DTL) and 3 instantaneous/DTL characteristics (Lowset, Highset 1 and Highset 2) are provided.

#### 1.4.1.1 Time Delayed Characteristic

#### Operate Level

	Attribute	Value
$I_s$	Setting range	0.05, 0.1...2.50 xIn
$I_{op}$	Operate level	105 % $I_s$ , ± 4% or 1 % In
	Reset level	95 % $I_{op}$ ± 5% or 1 % In
	Repeatability	± 5 %
	Variation	-10 °C to +55 °C ≤ 5 %
		47 Hz to 52 Hz 57 Hz to 62 Hz harmonics to 550 Hz ≤ 5 %

#### Operate Time

	Attribute	Value
	Starter operate time	See Figure 1.5-2, ± 5 ms
<i>char</i>	Characteristic setting range	NI (IEC type A), VI (IEC type B), EI (IEC type C), LTI, DTL



	Attribute	Value
$T_m$	Time multiplier setting range	0.025, 0.050...1.600
$t_d$	Delay setting range	0.00, 0.01...20.00, 20.5 ...100, 101 ... 300 s
$t_{op}$	Operate time char = NI, VI, EI, LTI	$t = \frac{K}{\left[\frac{I}{I_s}\right]^\alpha - 1} \times T_m, \pm 5 \% \text{ absolute or } \pm 30 \text{ ms,}$ where $I$ = applied current, for char = NI : $K = 0.14, \alpha = 0.02$ (IEC type A) VI : $K = 13.5, \alpha = 1.0$ (IEC type B) EI : $K = 80.0, \alpha = 2.0$ (IEC type C) LTI : $K = 120.0, \alpha = 1.0$
	char = DTL	$t_d, \pm 1 \% \text{ or } \pm 10 \text{ ms}$
	Repeatability	$\pm 1 \% \text{ or } \pm 10 \text{ ms}$
	Overshoot time	< 40 ms
	Disengaging time	< 42 ms
	Reset setting	INST, 1, 2...60 s
	Variation 47 Hz to 52 Hz 57 Hz to 62 Hz harmonics to 550 Hz	$\leq 5 \%$

Figure 1.5-1 shows the operate times for the four IDMTL curves with a time multiplier of 1. Figure 1.5-2 shows the instantaneous operate times for the principal overcurrent starter. These operate times apply to non-directional characteristics. Where directional control is applied then the directional element operate time (section 1.4.4) should be added to give total maximum operating time.

#### 1.4.1.2 Lowset, Highset 1, Highset 2

##### Operate Level

	Attribute	Value
$I_s$	Setting range	0.05, 0.1...2.5, 3.0...52.5 x $I_n$
$I_{op}$	Operate level	100 % x $I_s, \pm 5 \% \text{ or } 1 \% I_n$
	Reset level	95 % $I_{op} \pm 5 \% \text{ or } 1 \% I_n$
	Repeatability	$\pm 5 \%$
	Transient overreach (X/R $\leq 100$ )	$\leq 5 \%$
	Variation -10 °C to +55 °C 47 Hz to 52 Hz 57 Hz to 62 Hz harmonics to 550 Hz	$\leq 5 \%$
		$\leq 5 \%$

##### Operate Time

	Attribute	Value
$t_{start}$	Starter operate time	see Figure 1.5-3 and Figure 1.5-4, $\pm 5 \text{ ms}$
$t_d$	Delay setting	0.00, 0.01...20.00, 20.5 ...100, 101 ... 300 s
$t_{op}$	Operate time	$t_d + t_{start}, \pm 1 \% \text{ or } \pm 10 \text{ ms}$
	Repeatability	$\pm 1 \% \text{ or } \pm 10 \text{ ms}$
	Overshoot time	< 40 ms
	Disengaging time	< 42 ms
	Variation 47 Hz to 52 Hz 57 Hz to 62 Hz harmonics to 550 Hz	$\leq 5 \%$

Figure 1.5-3 and Figure 1.5-4 show the instantaneous highset and lowset outputs. These instantaneous operate times i.e. delay setting  $t_d = 0.005$  apply to non-directional characteristics. Where directional control is applied then the directional element operate time (section 1.4.4) should be added to give total maximum operating time.

## 1.4.2 Earth-fault Overcurrent Protection

A main characteristic (IDMTL, DTL) and 3 DTL characteristics (Lowset, Highset 1 and Highset 2) are provided.

### 1.4.2.1 Time Delayed Characteristic

Specification as for phase-fault overcurrent (section 1.4.1.1).

### 1.4.2.2 Lowset, Highset 1, Highset 2

Specification as for phase-fault overcurrent (section 1.4.1.2).

## 1.4.3 Sensitive/Restricted Earth-fault Protection

A single element with three timing characteristics (lowset, DTL1 and DTL2) is provided.

### Operate Level

	Attribute	Value
$I_s$	Current setting	0.005, 0.010...0.960 $\times I_n$
$I_{op}$	Operate level	100 % $I_s$ , $\pm 5\%$ or 1 % $I_n$
	Reset level	95 % $I_{op}$ , $\pm 5\%$ or 1 % $I_n$
	Repeatability	$\pm 1\%$
	Variation	-10 °C to +55 °C
		47 Hz to 52 Hz
		57 Hz to 62 Hz
		$\leq 5\%$
		$\leq 5\%$

Note. SEF relays are required to suppress 2<sup>nd</sup>, 3<sup>rd</sup> and higher harmonics and have a frequency response at minimum setting as shown in Figure 1.5-5.

### Operate Time

	Attribute	Value
$t_{lowset}$ , $t_{DTL1}$ , $t_{DTL2}$	Delay setting (lowset, DTL1, DTL2)	0.00, 0.01...20.00, 20.5 ...100, 101 ... 300 s
	Operating time	lowset
		DTL1
		DTL2
		$t_{lowset}$ , $\pm 1\%$ or $\pm 10$ ms
		$t_{DTL1}$ , $\pm 1\%$ or $\pm 10$ ms
		$t_{DTL1} + t_{DTL2}$ , $\pm 1\%$ or $\pm 10$ ms
	Repeatability	$\pm 1\%$ or $\pm 10$ ms
	Overshoot time	< 40 ms
	Disengaging time	< 42 ms
	Variation	47 Hz to 52 Hz
		57 Hz to 62 Hz
		$\leq 5\%$

Figure 1.5-6 shows the sensitive earth fault starter output. This instantaneous operate time applies to non-directional characteristics. Where directional control is applied then the directional element operate time (section 1.4.4) should be added to give total maximum operating time.

## 1.4.4 Directional Characteristics

*Applies to Argus 2 and Argus 6 relays only.*

Directional characteristics can be applied to phase-fault overcurrent elements, earth-fault overcurrent elements and single-pole sensitive earth-fault models.

Two types of directional element exist, referred to below as type I and type II. On a particular model the type of element in the relay can be identified from the range of the angle setting as listed below: -

**Operate Angle**

	Attribute		Value
$\theta_s$	Angle setting	Phase-fault	type I: +30, +45 ° type II: -90, -89...0, +1...+90 °
		Earth-fault	type I: 0, -15, -45, -65 ° (see note below) type II: -90, -89...0, +1...+90 °
CA	Characteristic angle (I with respect to V)	type I at 50 Hz, type II	$\theta_s, \pm 5^\circ$
		type I at 60 Hz	Phase-fault: $+25 \pm 5^\circ$ or $+40 \pm 5^\circ$ Earth-fault: $0 \pm 5^\circ, -13 \pm 5^\circ, -46 \pm 5^\circ$ or $-67 \pm 5^\circ$
	Operating angle	forward	CA - $87.5^\circ \pm 5^\circ$ to CA + $87.5^\circ \pm 5^\circ$
		reverse	(CA - $180^\circ$ ) - $87.5^\circ \pm 5^\circ$ to (CA - $180^\circ$ ) + $87.5^\circ \pm 5^\circ$
	Variation in characteristic angle	10°C to +55°C	$\pm 5^\circ$
		47 Hz to 52 Hz	type I: $\pm 2.5^\circ$ per 5 Hz variation
		57 Hz to 62 Hz	type II: $\pm 2.5^\circ$

Note. Some models are available in which the -65 ° setting is replaced by a -90 ° setting.

**Operate Threshold**

	Attribute		Value
	Minimum levels for operation	I	> 5 % I <sub>n</sub>
		V (p/f)	> 2 V
		V (e/f)	> 3.3 V

**Operate Time**

	Attribute	Value
	Operate time	type I: typically 20 ms at characteristic angle type II: typically 40 ms at characteristic angle
	Reset time	type I: typically 20 ms at characteristic angle type II: typically 40 ms at characteristic angle

See Figure 1.5-7.

**1.4.5 Circuit Breaker Fail****Operate Level**

	Attribute	Value
$I_s$	Phase Fault setting	Off, 0.05, 0.1 ... 1.0 x I <sub>n</sub>
$I_s$	Earth Fault Setting	Off, 0.05, 0.1 ... 1.0 x I <sub>n</sub>
$I_s$	SEF Setting	Off, 0.05, 0.1 ... 1.0 x I <sub>n</sub>
$I_{op}$	Operate Level	100 % $I_s \pm 5\%$ or 1 % I <sub>n</sub>
	Reset Level	95 % $I_{op}, \pm 5\%$ or 1 % I <sub>n</sub>
	Repeatability	$\pm 1\%$
	Variation	47 Hz to 52 Hz 57 Hz to 62 Hz harmonics to 550 Hz $\leq 5\%$

**Operate Time**

	Attribute	Value
$t_{CBF1},$ $t_{CBF2}$	Delay setting (retrip, backtrip)	0.00, 0.01...20.00, 20.5 ...100, 101 ... 300 s

Attribute	Value
Operating time	retrip $t_{CBF1}, \pm 1 \% \text{ or } \pm 10 \text{ ms}$
	backtrip $t_{CBF1} + t_{CBF2}, \pm 1 \% \text{ or } \pm 10 \text{ ms}$
Repeatability	$\pm 1 \% \pm 10 \text{ ms}$
Overshoot time	< 40 ms
Disengaging time	< 42 ms

### 1.4.6 Auto-reclose

Integrated with the Overcurrent, Low Set, Delay and High Set 1 and High Set 2 elements.

Attribute	Value
Number of reclose shots	up to 4 (separate for phase-fault, earth-fault, SEF and external)
Timers	Reclose DTL 1, 2, 3, 4; Reclaim time (separate for phase-fault, earth-fault, SEF and external)
Timer ranges	0.20, 0.21...2.0, 2.1...20, 21...300, 360...3600, 3900...14400 s
Time accuracy, all timers	setting $\pm 1 \% \text{ or } 10 \text{ ms}$
Repeatability	$\pm 1 \%$

### 1.4.7 Instrumentation

Voltage, power and power factor instruments are available on Argus 2 type II models only.

	Instrument Value	Reference	Typical accuracy	Claimed accuracy
$I$	Current	$I \geq 0.1 \times I_n$	$\pm 1 \% I_n$	$\pm 3 \% I_n$
$V$	Voltage	$V \geq 0.8 \times V_n$	$\pm 1 \% V_n$	$\pm 3 \% V_n$
	Power, real and apparent	$V = V_n, I \geq 0.1 \times I_n, pf \geq 0.8$		$\pm 3 \% P_n$ , where $P_n = V_n \times I_n$
$pf$	Power factor	$V = V_n, I \geq 0.1 \times I_n, pf \geq 0.8$		$\pm 0.05$

### 1.4.8 Communication Interface

Attribute	Value
Physical layer	Fibre-optic (option EIA RS-485)
Connectors	ST <sup>TM</sup> (BFOC/2.5) (RS-485 electrical 4mm terminal)
Recommended fibre	62.5/125 $\mu\text{m}$ glass fibre with ST <sup>TM</sup> connector
Launch power (into recommended fibre)	-16 dBm
Receiver sensitivity	-24 dBm
Protocol	IEC 60870-5-103 or MODBUS RTU

'ST' is the registered trade mark of AT&T Co.

### 1.4.9 Real Time Clock

Attribute	Value
Accuracy	$\pm 50 \text{ ppm}$ (equivalent to $\pm 180 \text{ ms per hour}$ )

## 1.5 Environmental Performance

### 1.5.1 General

#### 1.5.1.1 Temperature

IEC 60068-2-1/2

Type	Level
Operating range	-10 °C to +55 °C
Storage range	-25 °C to +70 °C

## 1.5.1.2 Humidity

IEC 60068-2-3

Type	Level
Operational test	56 days at 40 °C and 95 % relative humidity

## 1.5.1.3 Insulation

IEC 60255-5

Type	Level
Between any terminal and earth	2.0 kV AC RMS for 1 min
Between independent circuits	
Across normally open contacts	1.0 kV AC RMS for 1 min

## 1.5.1.4 IP Ratings

Type	Level
Installed with cover on	IP 51
Installed with cover removed	IP 30

## 1.5.2 Immunity

## 1.5.2.1 Auxiliary DC Supply Variation

Quantity	Value
Allowable superimposed ac component	≤ 12% of DC voltage
Allowable breaks/dips in supply (collapse to zero from nominal voltage)	≤ 20ms

## 1.5.2.2 High Frequency Disturbance

IEC 60255-22-1 Class III

Type	Level	Variation
Common (longitudinal) mode	2.5 kV	≤ 3 %
Series (transverse) mode	1.0 kV	

## 1.5.2.3 Electrostatic Discharge

IEC 60255-22-2 Class III

Type	Level	Variation
Contact discharge	8.0 kV	≤ 5 %

## 1.5.2.4 Radiated Radio Frequency Interference

IEC 60255-22-3 Class III

Type	Level	Variation
20 MHz to 1000 MHz	10 V/m	≤ 5 %

## 1.5.2.5 Fast Transients

IEC 60255-22-4 Class IV

Type	Level	Variation
5/50 ns 2.5 kHz repetitive	4kV	≤ 3 %

## 1.5.2.6 Surge Immunity

IEC 60255-22-5

Type	Level	Variation
Between all terminals and earth, or between any two independent circuits	4.0 kV, 1.2/50 $\mu$ s or 8/20 $\mu$ s	$\leq 5\%$

## 1.5.2.7 Conducted Radio Frequency Interference

IEC 60255-22-6

Type	Level	Variation
0.15 to 80 MHz	10 V	$\leq 5\%$

## 1.5.3 Emissions

## 1.5.3.1 Radiated Radio Frequency Interference

IEC 60255-25

Type	Limits at 10 m, Quasi-peak
30 to 230 MHz	40 dB( $\mu$ V)
230 to 10000 MHz	47 dB( $\mu$ V)

## 1.5.3.2 Conducted Radio Frequency Interference

IEC 60255-25

Type	Limits	
	Quasi-peak	Average
0.15 to 0.5 MHz	79 dB( $\mu$ V)	66 dB( $\mu$ V)
0.5 to 30 MHz	73 dB( $\mu$ V)	60 dB( $\mu$ V)

## 1.5.4 Mechanical

## 1.5.4.1 Vibration (Sinusoidal)

IEC 60255-21-1 Class I

Type	Level	Variation
Vibration response	0.5 gn	$\leq 5\%$
Vibration endurance	1.0 gn	

## 1.5.4.2 Shock and Bump

IEC 60255-21-2 Class I

Type	Level	Variation
Shock response	5 gn, 11 ms	$\leq 5\%$
Shock withstand	15 gn, 11 ms	
Bump test	10 gn, 16 ms	

## 1.5.4.3 Seismic

IEC 60255-21-3 Class I

Type	Level	Variation
Seismic response	1 gn	$\leq 5\%$

## 1.5.4.4 Mechanical Classification

Type	Level
Durability	$> 10^6$ operations

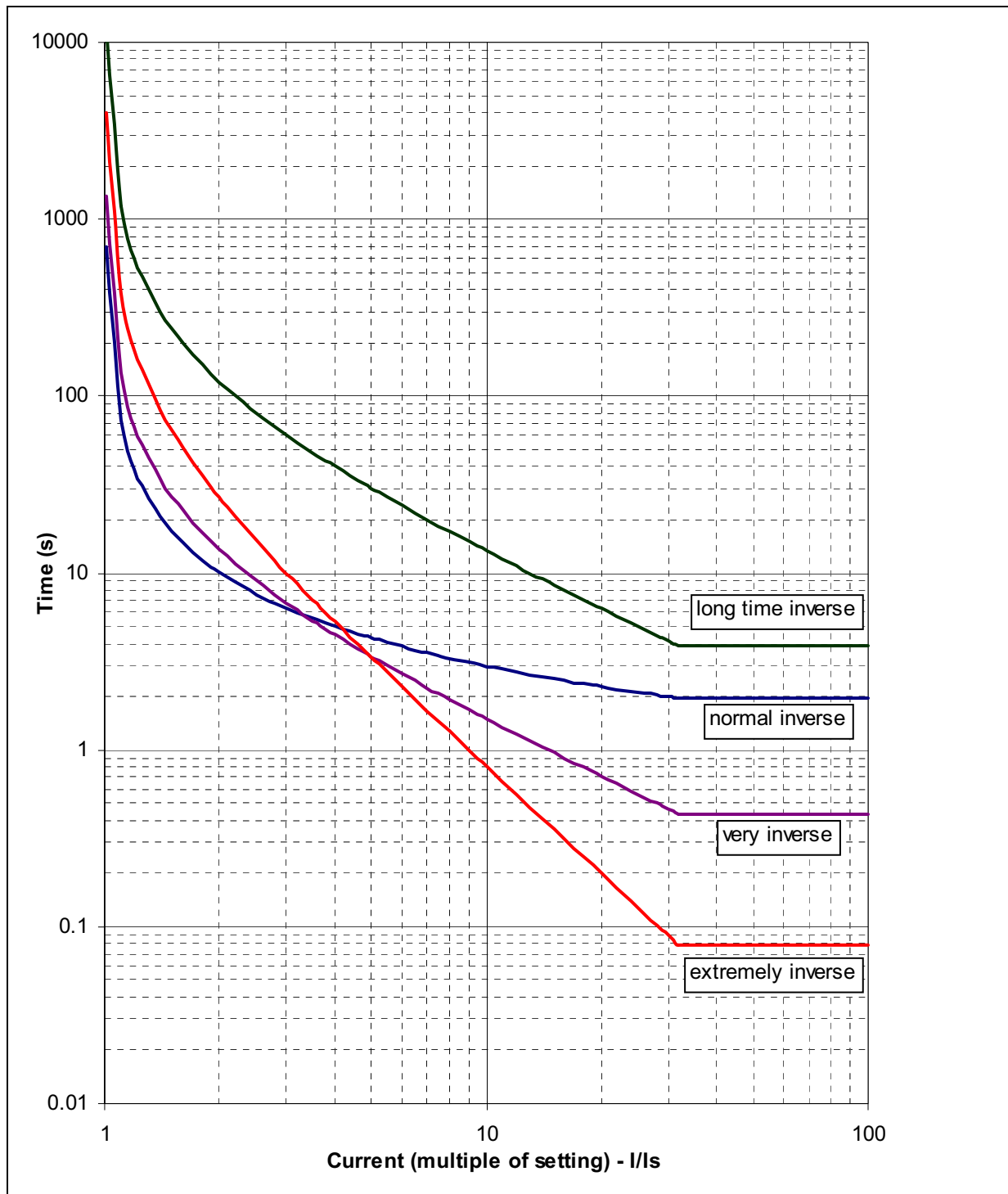


Figure 1.5-1 IDMTL Curves (Time Multiplier=1)

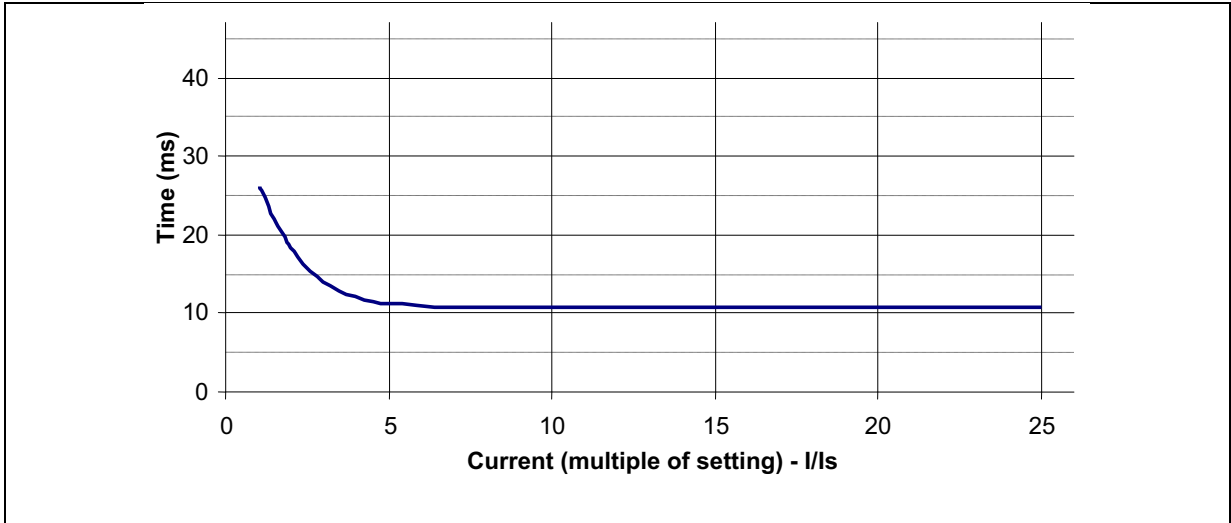


Figure 1.5-2 Overcurrent Starter Operate Time to Contact

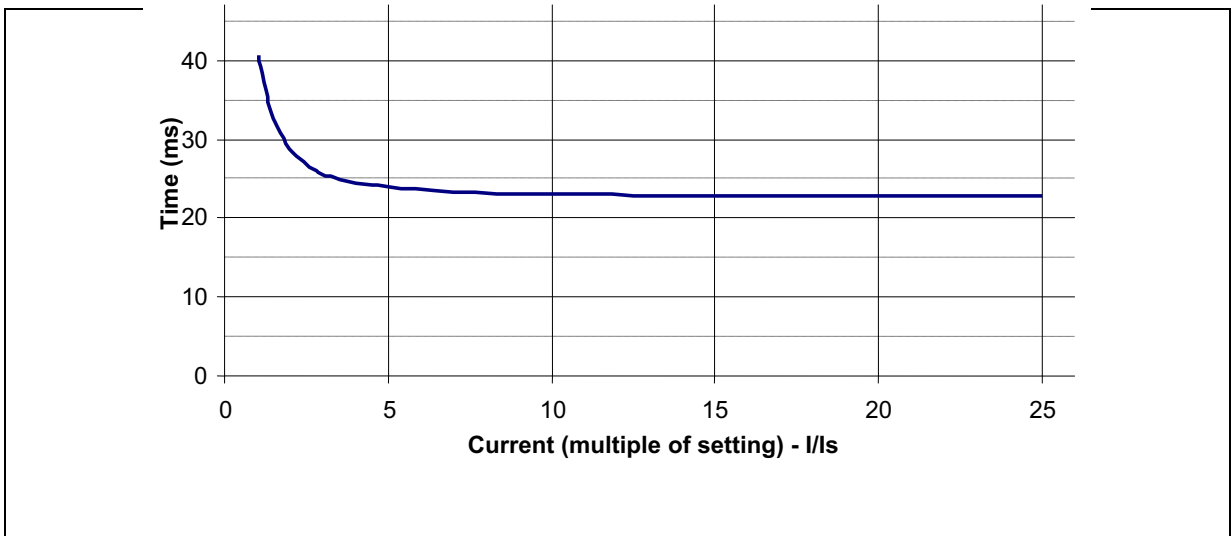


Figure 1.5-3 Instantaneous Highset Operate Time to Contact

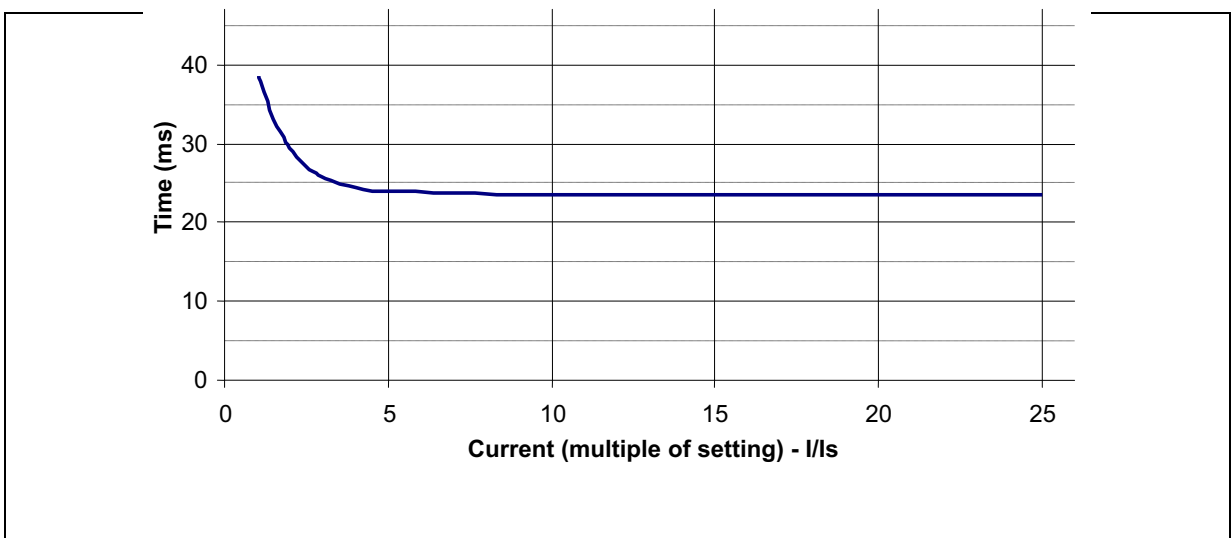


Figure 1.5-4 Instantaneous Lowset Operate Time to Contact



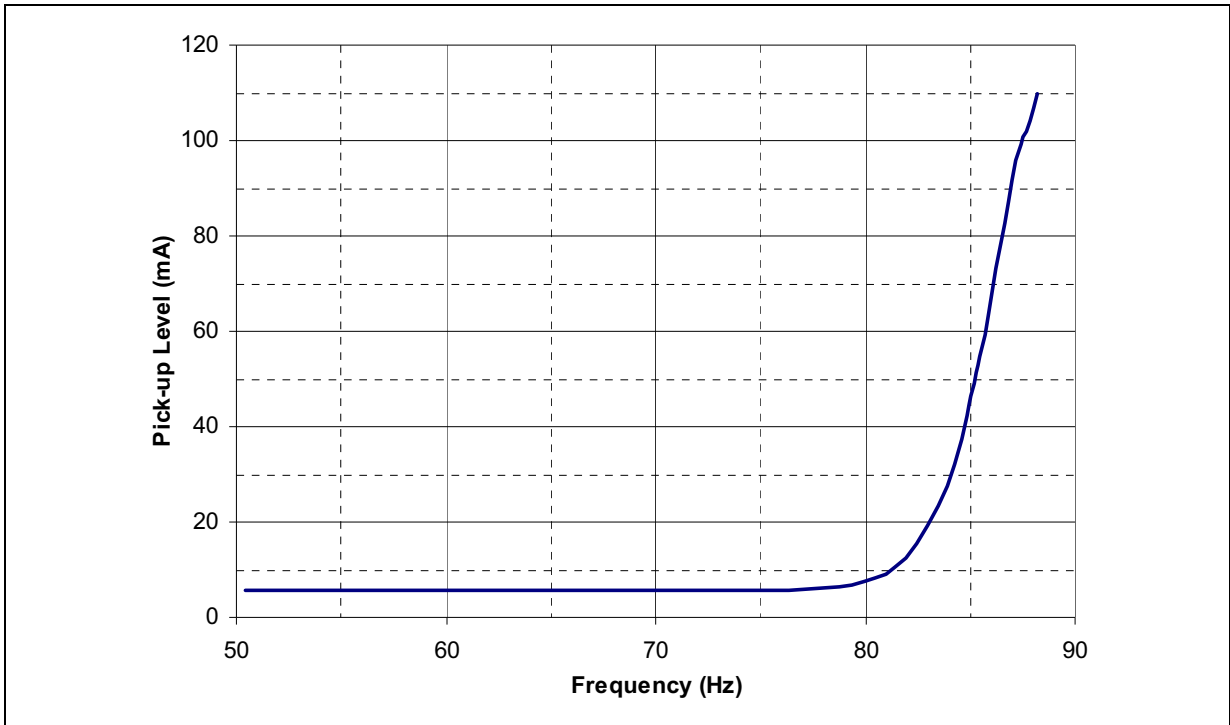


Figure 1.5-5 Sensitive Earth-fault Frequency Response ( $I_s = 5 \text{ mA}$ )

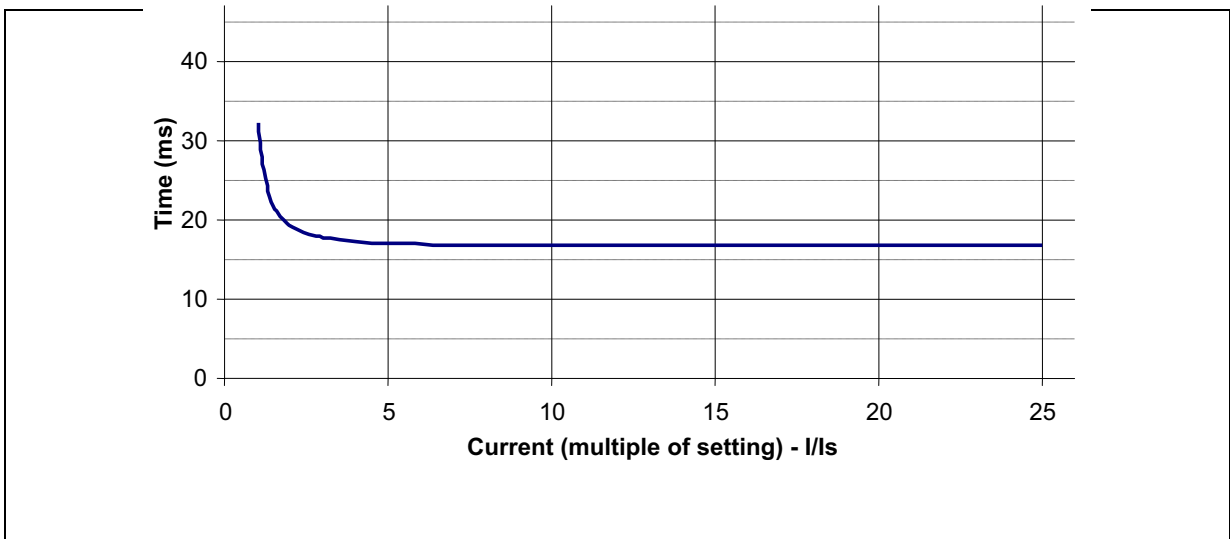


Figure 1.5-6 Sensitive Earth-fault Operate Time to Contact

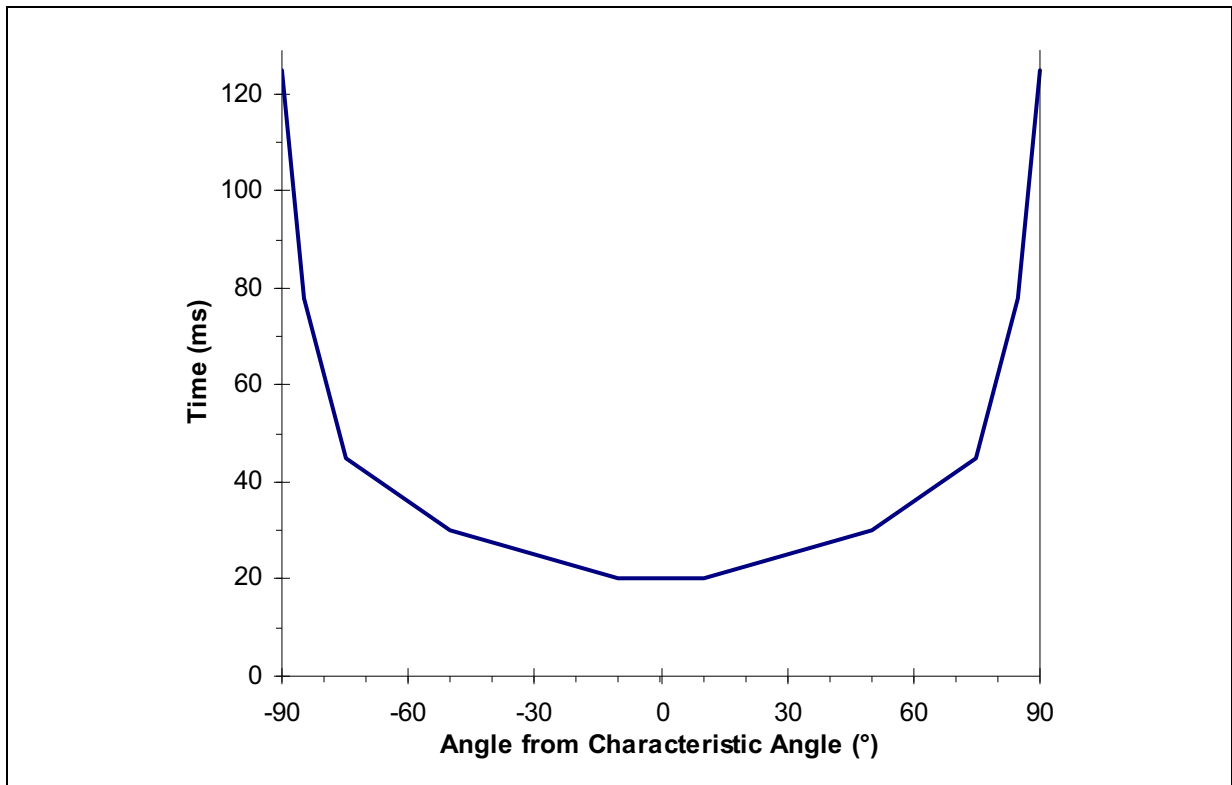


Figure 1.5-7 Directional Timing Characteristic

## Section 2: Functional Description

### 2.1 Introduction

The Argus overcurrent relays incorporate a range of protection elements and functions that, together with the integrated control, automation, display and communication functions, provide comprehensive protection for application in distribution substations or backup protection on transmission feeders.

The protective functions that can be provided are shown in Figure 2.1-1, together with the analogue and digital input signals and outputs.

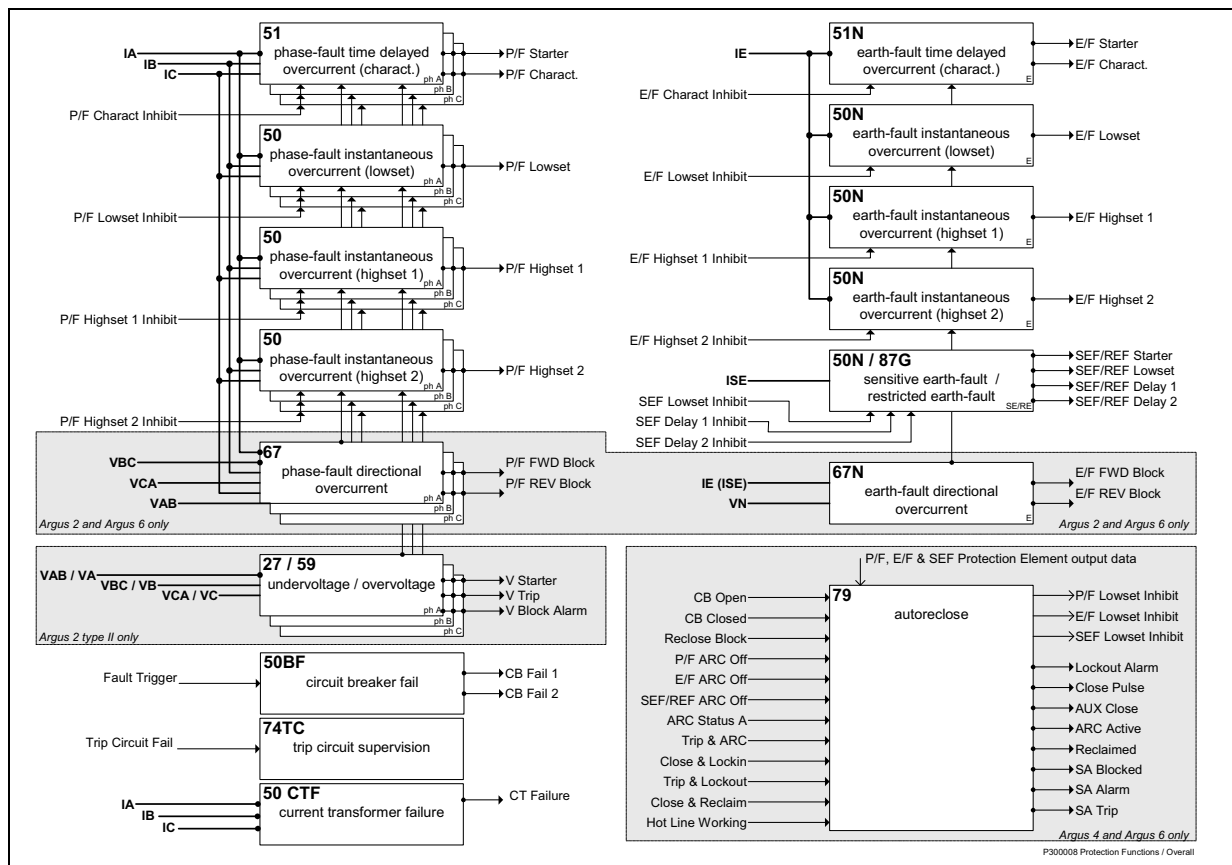


Figure 2.1-1 Overview of Argus Relay Protection Functions

Scaled analogue inputs are derived via input transformers. Control/inhibit input signals and output relays can be user mapped to be raised from any one, or more, status inputs; similarly, protection, alarm and control element outputs can be user mapped to output relays. The user can thus create an individual Input/Output matrix mapping specific to each installation. Each status input can be set to be inverted and/or latched and have pick-up and drop-off delay times set. Each output relay may be individually set to be latched (Hand Reset).

The flexibility of this input/output mapping coupled to the Protection and Control functions and Settings Group selection enables users to integrate scheme functions into the ARGUS Relay to produce a sophisticated protective device

Each of the functions shown in Figure 2.1-1 is described in the relevant sections below.

## 2.1.1 Models

A variety of Argus overcurrent protection models is available. Different combinations of the functions shown in Figure 2.1-1 are provided in each model to achieve different protective requirements.

Four series of relays are provided within the range:

- Argus 1 – overcurrent protection
- Argus 2 – directional overcurrent protection
- Argus 4 – overcurrent protection and integrated autoreclose
- Argus 6 – directional overcurrent protection and integrated autoreclose

Two types of current input circuits are used in the Argus range. One is used for phase-fault (P/F) and earth-fault (E/F) protection. The second type provides harmonic filtering and is used for sensitive earth-fault (SEF) and restricted earth-fault (REF) protection.

Two types of directional/voltage inputs are used in the Argus 2 series. Type I provides a fixed set of characteristic angles; type II allows any angle to be set and provides a voltage protection element and voltage and power measurands. Argus 6 series relays all have a type I voltage input.

The Diagrams and Parameters document for each series lists explicitly the functions that are provided within each model.

## 2.1.2 Document Organisation

The remainder of Section 2: Functional Description is organised as follows:

**Table 2-1 Overview of Functional Description Sections**

Section		Principal Setting Menus	Description
2.2	Configuration	<u>System Config.</u>	Configuration of Argus for system requirements: system frequency, CT/VT ratios, identifiers, password etc.
2.3	Phase-Fault and Earth-fault Overcurrent	<u>Protection</u>	51 phase-fault time delayed overcurrent (charact.) 50 phase-fault instantaneous overcurrent (lowset) 50 phase-fault instantaneous overcurrent (highset 1) 50 phase-fault instantaneous overcurrent (highset 2) 51N earth-fault time delayed overcurrent (charact.) 50N earth-fault instantaneous overcurrent (lowset) 50N earth-fault instantaneous overcurrent (highset 1) 50N earth-fault instantaneous overcurrent (highset 2)
2.4	Sensitive Earth-fault and Restricted Earth-fault	<u>Protection</u>	50N sensitive earth-fault, or 87G restricted earth-fault
2.5	Circuit Breaker Fail	<u>Protection</u>	50BF circuit breaker fail
2.6	Cold Load Protection	<u>System Config. + Auto-reclose</u>	Application of different settings group when energising a cold load.
2.7	Directional	<u>Directional</u>	67 phase-fault directional overcurrent 67N earth-fault directional overcurrent
2.8	Voltage Protection	<u>Voltage</u>	27/59 undervoltage/overvoltage protection
2.9	Auto-reclose	<u>Auto-reclose</u>	79 auto-reclose
2.10	Trip Circuit Supervision	<u>Status Config.</u>	74TC trip circuit supervision
2.11	Status Inputs and Relay Outputs	<u>Status Config. + O/P Relay Config.</u>	Pick-up and drop-off timers, inversion, latching and minimum energise time.
2.12	Communications	<u>Communications</u>	Communication with PC or control system.
2.13	Data Storage	<u>Data Storage</u>	Event, fault and waveform records.
2.14	Maintenance	<u>CB Maintenance</u>	Assistance for maintenance of circuit breakers, protection schemes and the Argus relay.
2.15	Linesman	<u>Linesman Mode</u>	Enables easy enabling/disabling of protection and auto-reclosing for line work.

### Notes

1. Within Section 2: Functional Description the following notational and formatting conventions are used:

- Item in menu structure: Item
- Setting: sub-menu:setting\_name
- Setting value: value
- Alternatives: [1st] [2nd] [3rd]

2. The purpose of this document is to describe the capabilities and functionality of the Argus Overcurrent Protection relays. The User Manual document describes how to set up and operate the Argus: apply configuration, settings and passwords, view instruments and set default instruments, and retrieve fault data.

## 2.2 Configuration

This section provides advice for configuring the Argus relay via the Settings.MODE.:System.Config.: menu to suit the overall requirements of the system and the protection scheme: e.g. system frequency, CT/VT ratios, identifiers, user alarm text, date & time, password, etc.

### 2.2.1 Settings Groups

Settings groups are used to parameterise the protection and configuration of the Argus relay. Eight Groups each containing a completely independent set of setting values can be stored in the relay, only the designated Group as set in System.Config.:Active.Setting.Group.=G<sub>n</sub> will be active i.e. applied, at a time. Examples of uses for settings groups: i.e. summer and winter settings, cold load settings, alternative settings values to cover special temporary situations, test settings, embedded generation in/out settings etc.

Some settings are common across all groups e.g. Relay Identifier etc. Settings that can be set to a unique value in each group have a setting description beginning with G<sub>n</sub>, where *n* is the number of the Group currently being displayed e.g. G1 . The settings in any Group can be accessed for editing via System.Config.:Settings.group.Edit/View.=G<sub>n</sub> including the currently Active Group; it is, however, strongly recommended that editing of settings is only done in a setting group that it is off-line i.e. not-active.

To assist in the parameterisation of different settings groups, where only a few settings differ, after entering user settings into one group the completed set of setting values can be copied from that group to another using the System.Config.:Copy.Group.From.G<sub>n</sub>to.G<sub>x</sub> setting, note that settings cannot be copied to the currently active group. Necessary settings changes may then be implemented.

Any group as set in Status.Config.:Settings.Group.Select can be selected dynamically, while the Relay is in-service, by raising the designated status input. When that status input is cleared, the settings group reverts to the previously active group, as specified by another status input or System.Config.:Active.Settings.Group. If more than one status input is raised at the same time, the group associated with the lowest number status input takes precedence. e.g. Status 2 - Group 8 takes precedence over Status 3 - Group 2. Change of group takes typically 15 ms but less than 17.5 ms.

Argus 2 - 500 series relays with a type II voltage input can also be programmed to change settings group on the operation of the voltage element, forcing a group change regardless of any starters which may be raised. This function can be used to set-up the Argus 2 to implement Voltage Controlled Overcurrent operation. Change of group takes typically 40 ms but less than 50 ms.

**Table 2-2 Settings Group Settings**

Sub-menu: **System Config.**

Setting name	Range ( <b>bold</b> = default)	Units	Notes
<b>Active Settings Group</b>	1,2...8		
<b>Settings Group Edit/View</b>			
<b>Copy Group</b>	From 1,2...8 to 1,2...8		

Sub-menu: **Status Config.**

Setting name	Range ( <b>bold</b> = default)	Units	Notes
<b>Settings Group Select</b>	_, 1, 2...8 for each status input (and Vop) (default: _ _ _ _ _ _ _ _ _ _)		<i>Argus 2 type II relays can change settings group from operation of the voltage element.</i>

### 2.2.2 System Frequency

The relay can be user set for nominal 50 Hz or 60 Hz operation using System.Config.:Power.System.Frequency.

**Table 2-3 System Frequency Setting**Sub-menu: **System Config.**

Setting name	Range ( <b>bold = default</b> )	Units	Notes
<b>Power System Frequency</b>	<b>50, 60</b>	Hz	

## 2.2.3 Current and Voltage Inputs

### Input Type Selection

On 3-pole models and 4-pole models with an SEF/REF input, the user can set the 'pole B' current input to be either the phase-fault B input (P/F) or an earth-fault input (E/F) using the System Config.:Set Pole B Type setting. When the input is set to P/F all settings related to the earth-fault will be hidden from view.

When an SEF/REF input is provided, its designation can be set to show 'SEF' or 'REF' using the System Config.:Earth Fault Mode Select setting. This changes only the text identifier which appears in various locations within the menu system, not the functionality of the element.

### Phase Rotation

The setting System Config.:Phase Rotation allows the user to select the applicable system phase rotation.

### Ratings and CT/VT Ratios

The current input for each pole can be user selected for operation from a 1A or 5A CT secondary. The appropriate connections are made on the relay terminals. The appropriate rating should be set using the System Config.:P/F [E/F] [SEF/REF] Rating (In) settings to allow the Argus to correctly calculate the measured current for display purposes. This setting will not affect the Protection Menu setting's display if they are displayed as xIn, however see Current Display Bases below.

CT and VT ratios can be set, allowing the relay to calculate primary currents and voltages for display.

VT settings appear on Argus 2 relays with type II directional elements only. In addition to the VT ratio setting a VT connection setting allows a three phase-earth VT to be used, with the relay calculating the neutral voltage internally.

### Current Display Bases

The System Config.:Current Display setting allows the overcurrent protection settings to be displayed in primary amps, secondary amps, or xIn i.e. multiple of relay nominal current. The user can thus enter settings in the most convenient units. The Argus will perform the necessary conversion if the display units are changed.

**Note.** For the Argus to correctly calculate these values, the nominal CT Secondary Ratings and CT Ratios must be correctly entered, see above.

**Table 2-4 Current and Voltage Input Settings**Sub-menu: **System Config.**

Setting name	Range ( <b>bold = default</b> )	Units	Notes
<b>Set Pole B Type</b>	<b>P/F, E/F</b>		<i>Some Argus 1 and 2 models only</i>
<b>Earth Fault Mode Select</b>	<b>SEF, REF</b>		<i>Models with SEF only</i>
<b>Phase Rotation</b>	<b>A-B-C, A-C-B</b>		<i>Argus 2 (type II) only</i>
<b>P/F Rating (In)</b> <b>E/F Rating (In)</b> <b>SEF/REF Rating (In)</b>	<b>1, 5</b>	A	
<b>P/F CT Ratio</b> <b>E/F CT Ratio</b> <b>SEF/REF CT Ratio</b>	<b>5, 10, 15...300...10000 : 1, 5</b>		
<b>VT Connection</b>	<b>Ph-N, Ph-Ph</b>		
<b>VT Primary</b>	0, 1...9 for each of 6 digits (default: <b>11000</b> )	V	<i>Argus 2 (type II) only</i>
<b>VT Secondary</b>	40.0, 40.1...70.0, 70.5... <b>110.0</b> ...150.0	V	
<b>Current Display</b>	<b>xIn, PRIMARY, SECONDARY</b>		

Setting name	Range ( <b>bold</b> = default)	Units	Notes
<b>Export power / lag VAR Sign</b>	<del>+ve/+ve</del> , +ve/-ve, -ve/+ve, -ve/-ve,		

## 2.2.4 Identifier

User defined identifying text can be programmed into the relay using the System Config::Set Identifier setting. This text is displayed on the title screen of the Argus and is used in communications with ReyDisp to identify the Argus relay.

**Table 2-5 Identifier Setting**

Sub-menu: **System Config.**

Setting name	Range ( <b>bold</b> = default)	Units	Notes
<b>Set Identifier</b>	ABCDEFGHIJKLMN <strong>OPQRSTU</strong> WXYZ1234567890 -+/ (default = <b>ARGUS n</b> e.g. <b>ARGUS 1</b> )		<i>Up to 16 characters</i>

## 2.2.5 General Alarms

General Alarms are user-defined text messages displayed on the LCD when mapped status inputs are raised. Up to five general alarms can be programmed, however this is limited by the number of status inputs on the device. Each general alarm can be triggered from one or more status inputs, as programmed by the appropriate setting.

The System Config::SET Alarm n setting (where *n* is the alarm number) allows the user to programme a text message which is displayed on the LCD when the associated status inputs are raised, as set by Status Config::Alarm n. The general alarm will also generate an event. If it is wished to operate an output contact for the alarm this can be programmed using the status input to output relay mapping (section 2.11).

If multiple alarms are active simultaneously the messages are linked in series in a rolling display on the LCD, separated by a '+' character. If it is necessary to display alarm messages longer than 13 characters then a status input may be mapped to multiple alarms, in which case a longer message will result.

All general alarms raised when a Fault Trigger is generated will be logged into the Fault Data record, transient general alarms will thus be latched and displayed at the end of the scrolling 'Fault Data' screen, see section 2.13.2

**Table 2-6 General Alarm Settings**

Sub-menu: **System Config.**

Setting name	Range ( <b>bold</b> = default)	Units	Notes
<b>SET Alarm 1</b> <b>SET Alarm 2</b> ... <b>SET Alarm 5</b>	ABCDEFGHIJKLMN <strong>OPQRSTU</strong> VWXYZ 1234567890 -+/ ( <b>ALARM n</b> )		<i>Up to 13 characters per name</i>

Sub-menu: **Status Config.**

Setting name	Range ( <b>bold</b> = default)	Units	Notes
<b>Gn Alarm 1</b> <b>Gn Alarm 2</b> ... <b>Gn Alarm 5</b>	mappable to any status input (default= _____)		<i>Default - not mapped to any status</i>

## 2.2.6 Direction Tags

*Argus 2 and Argus 6 only*

User defined text names for the Forward and Reverse directions can be applied to assist in identification of fault direction. For example, 'FWD' could be renamed 'FEEDER X', and 'REV' renamed 'BUSBAR Y'.

Note: Directional Relay convention is such that current flowing away from a busbar flows in the Forward direction.

These identifiers are used in the fault records to identify the direction of the fault.

**Table 2-7 Direction Settings**Sub-menu: **System Config.**

Setting name	Range ( <b>bold = default</b> )	Units	Notes
<b>FWD Name Tag</b>	ABCDEFGHIJKLMN <strong>OP</strong> QRSTU VWXYZ1234567890 -+/ <b>(FWD)</b>		<i>Argus 2 and Argus 6 only Up to 13 characters per name</i>
<b>REV Name Tag</b>	ABCDEFGHIJKLMN <strong>OP</strong> QRSTU VWXYZ1234567890 -+/ <b>(REV)</b>		

## 2.2.7 Real Time Clock

The date and time can be programmed and then maintained by the internal real time clock. The clock is also maintained for 2-3 week while the relay is de-energised. Additionally, in order to maintain synchronism within a substation, all Argus relays can be synchronised to the nearest second or minute using a mapped status input or via the IEC 60870-5-103 protocol Time Synchronising Frame.

The System Config.:Clock Sync. From Status setting specifies whether the clock will be synchronised to the nearest minute or second when the status input is activated.

**Table 2-8 Real Time Clock Settings**Sub-menu: **System Config.**

Setting name	Range ( <b>bold = default</b> )	Units	Notes
<b>Calendar – Set Date</b>	DD/MM/YY ( <b>01/01/00</b> )		
<b>Clock - Set Time</b>	HH:MM:SS ( <b>00:00:00</b> )		<i>When user presses 'ENTER' after editing, seconds are zeroed and clock begins counting.</i>
<b>Clock Sync. From Status</b>	<b>Minutes</b> , Seconds		

Sub-menu: **Status Config.**

Setting name	Range ( <b>bold = default</b> )	Units	Notes
<b>Gn Clock Sync</b>	_, 1 for each status input (default: _ _ _ _ _ _ _ _)		<i>Default - not mapped to any status</i>

## 2.2.8 Default Instruments

When a user stops accessing the keypad e.g. on leaving the Sub/Station the relay will, after a user set delay, automatically switch to default metering whereby the user selected default instruments are displayed in turn at 5 seconds intervals without user intervention. The time before this occurs is programmable with the System Config.:Default Screen Time setting.

The user can select/deselect the instruments to be displayed in the default metering cycle by going to the Instrument MODE., scrolling down to the required default instrument and using the **ENTER** key. This is described in detail in the User Manual document, section 1.3.4.

This function enables the user to set the relay to automatically return to displaying ammeters and other instruments such as ARC Status or Counters. Therefore, essential data is presented to visiting engineers without the need to negotiate the relay's HMI menu structure

**Table 2-9 Default Instrument Setting**Sub-menu: **System Config.**

Setting name	Range ( <b>bold = default</b> )	Units	Notes
<b>Default Screen Time</b>	10 sec, 60 sec, <b>5 min</b> , 1 hour		

## 2.2.9 Password

All settings on Argus relays can be password protected. The default password is 'NONE' making the password protection 'not active' therefore all settings can be edited without the relay requesting a password. If a password is set by the user then, before a setting can be changed, the set password must be entered. This allows access for further settings changes to be made without the need to re-enter the password each time. If the user then leaves



the relay keypad untouched for an hour the password protection is re-enabled. The Password setting is changed using the System Config.:Change Password setting. The user set password is also required to be entered for setting changes or commands performed via the communications link.

Note: if the password is lost/forgotten it can be recovered if the code number shown in the password screen is communicated to Siemens Protection Devices Limited.

**Table 2-10 Password Setting**

Sub-menu: **System Config.**

<u>Setting name</u>	<u>Range (bold = default)</u>	<u>Units</u>	<u>Notes</u>
<b>Change Password</b>	ABCDEFGHIJKLMN OPQRSTUVWXYZ 1234567890 -+/ <b>(NOT ACTIVE)</b>		4 characters

## 2.3 Phase-fault and Earth-fault Overcurrent

Argus relays can have up to three phase-fault poles and an earth-fault pole. Each pole has four overcurrent elements which can be used with the starters in blocking and protection schemes.

Phase-fault and earth-fault poles each have a delayed characteristic plus three instantaneous/definite time delay elements. In the directionally controlled Argus 2 and Argus 6 relays each phase-fault and earth-fault delay characteristic, lowset and highset 1 & 2 elements can be independently programmed via their directional control settings to non-directional, forward directional, reverse directional or bi-directional (tri-state) operation via the appropriate directional control setting, e.g. Protection:P/F Charact. Dir Control for the phase-fault delay characteristic element.

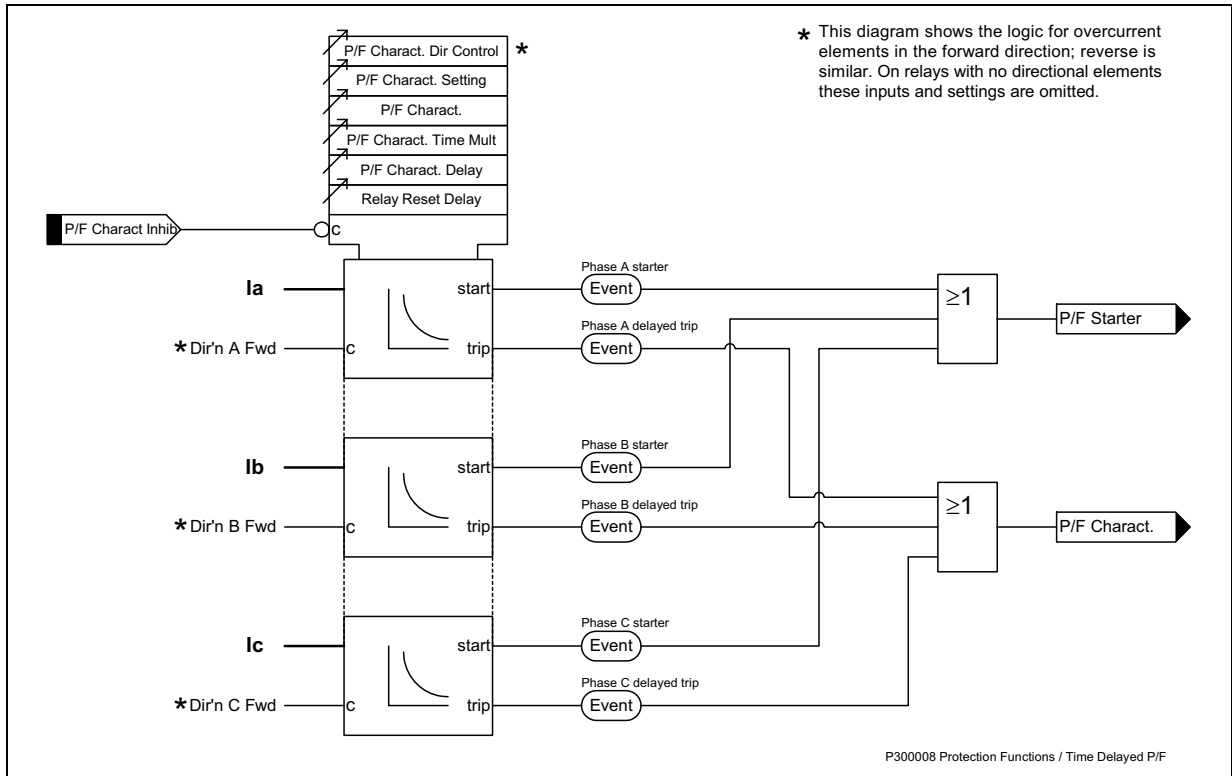
The operation start of each element can be inhibited from a mapped status input, set via the STATUS CONFIG MENU, to allow comprehensive blocking schemes to be developed. Furthermore, on Argus 2 relays with type II directional elements, the voltage element output can be set to raise inhibits.

The current input signals are sampled at a frequency of 1600 Hz (32 times per 50 Hz cycle) giving a flat frequency response between 47 Hz and 550 Hz, higher harmonics are also included in the r.m.s. calculation. This makes Argus ideal for applications where true RMS accuracy of measurement and timing must be maintained in the presence of high harmonic content in the current waveform e.g. protection of lines carrying variable speed motor loads or for capacitor bank protection.

### 2.3.1 Delay Characteristic element

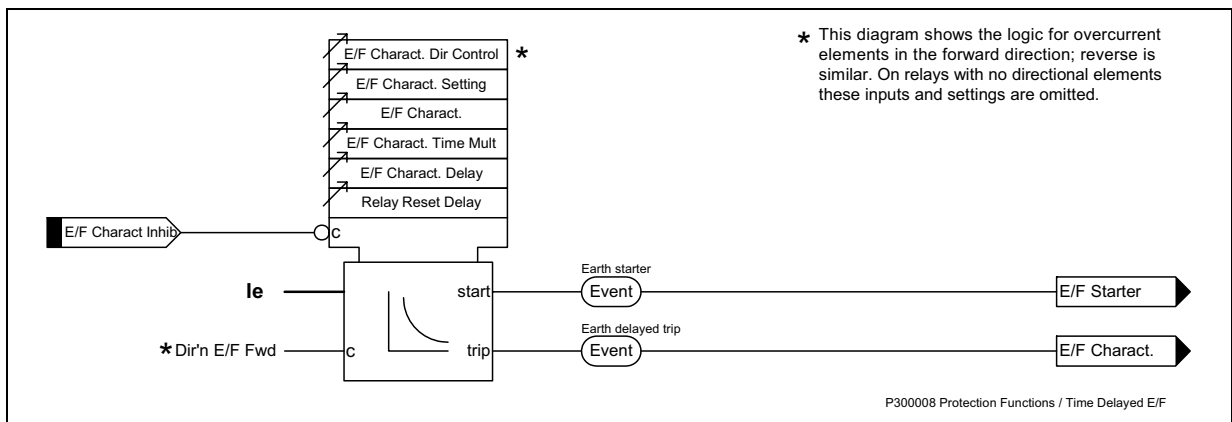
The Protection:P/F Charact. Setting enables the current level for the delay characteristic starter to be set. The Delay characteristic Protection:P/F Charact. Setting can be selected from Inverse Definite Minimum Time (IDMT) characteristic type Normal Inverse (NI) (IEC type A), Very Inverse (VI) (IEC type B), Extremely Inverse (EI) (IEC type C) and Long Time Inverse (LTI), or alternatively a Definite Time Lag (DTL) can be chosen. The time multiplier to be applied to the delay characteristic curve is set using the Protection:P/F Charact. Time Mult setting; if DTL has been selected this setting is replaced by the Protection:P/F Charact. Delay setting.

Each phase has an independent current-timing element and the algorithms integrate accurately for developing faults where current magnitude in each pole varies with time. Outputs are programmed using the 'O/P Relay Config.:P/F Starter' and 'O/P Relay Config.:P/F Charact.' settings for starter pick-up and delayed trip respectively.



**Figure 2.3-1 Functional Diagram – Characteristic Phase-fault Overcurrent Element**

The earth-fault pole similarly has its own delayed overcurrent element with its own starter setting and selectable IDMT/DTL characteristic.



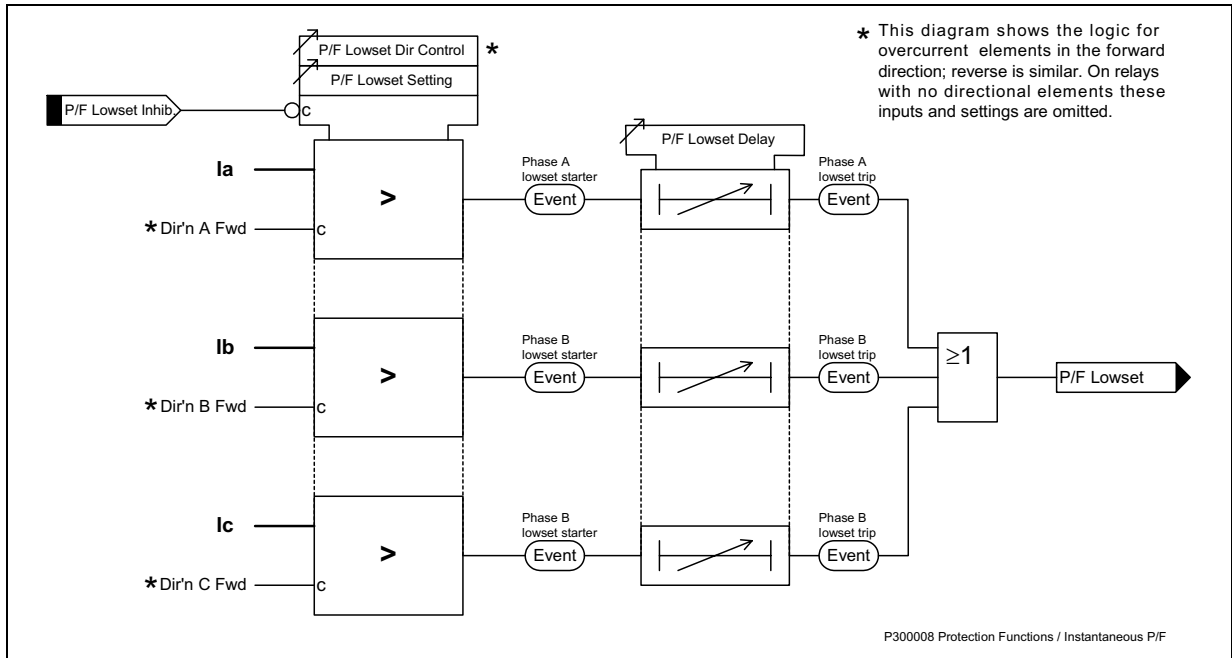
**Figure 2.3-2 Functional Diagram – Characteristic Earth-fault Overcurrent Element**

### 2.3.2 Instantaneous elements

There are three separate instantaneous elements per pole: Lowset, Highset 1 and Highset 2. The setting range of each element allows it to be set and used either as a lowset or highset protection, or for overcurrent monitoring. For each element common settings are used by each of the three phase fault poles of the relay, each element has an 'OFF' setting. Each element has a shaped instantaneous characteristic plus follower time delay which can be used to provide time grading margins, sequence co-ordination grading, or for scheme logic. The instantaneous elements have transient free, low overreach, operation under conditions of high values of system X/R.

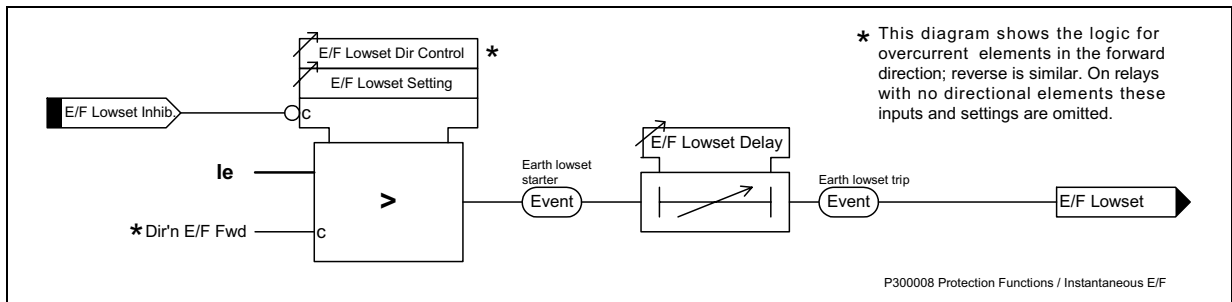
Figure 2.3-2 and the following text describe the operation of the Lowset element, Highset 1 and Highset 2. Each of these elements is identical in operation.

Each instantaneous element has its own directional control setting Protection:P/F Lowset Dir Control. A current level setting Protection:P/F Lowset Setting sets the pickup level, which can be followed by a time delay, Protection:P/F Lowset Delay, the element output is mapped Q/P Relay Config.:P/F Lowset.



**Figure 2.3-3 Functional Diagram – Instantaneous Phase-fault Overcurrent Elements**

The earth-fault pole similarly has its own Instantaneous Lowset, Highset1 and Highset2 overcurrent elements with their own starter settings and selectable DTL characteristic.



**Figure 2.3-4 Functional Diagram – Instantaneous Earth-fault Overcurrent Elements**

**Table 2-11 Phase-fault and Earth-fault Overcurrent Settings**

Sub-menu: **Protection**

Setting name	Range ( <b>bold = default</b> )	Units	Notes
<b>Gn P/F [E/F] Charact. Dir Control</b>	<b>OFF</b> , FWD, REV, TRI		<i>Argus 2 and Argus 6 only.</i>
<b>Gn P/F [E/F] Charact. Setting</b>	0.05, 0.10, 0.15... <b>1.00</b> ...2.50	xln	<i>see note 1 below</i>
<b>Gn P/F [E/F] Charact.</b>	<b>NI</b> , VI, EI, LTI, DTL		
<b>Gn P/F [E/F] Charact. Time Mult</b>	0.025, 0.050... <b>1.000</b> ...1.600	xt	<i>see note 1 below</i>
<b>Gn P/F [E/F] Charact. Delay</b>	0.00, 0.01... <b>5.00</b> ...20.00, 20.5 ...100, 101 ... 300	sec	
<b>Gn P/F [E/F] Lowset Dir Control</b>	<b>OFF</b> , FWD, REV, TRI		<i>Argus 2 and Argus 6 only.</i>
<b>Gn P/F [E/F] Lowset Setting</b>	OFF, 0.05, 0.10... <b>1.00</b> ...3.00, 3.5, 4.0...52.5	xln	<i>see note 1 below</i>
<b>Gn P/F [E/F] Lowset Delay</b>	<b>0.00</b> , 0.01...20.00, 20.5 ...100, 101 ... 300	sec	
<b>Gn P/F [E/F] Highset 1 Dir Control</b>	<b>OFF</b> , FWD, REV, TRI		<i>Argus 2 and Argus 6 only.</i>
<b>Gn P/F [E/F] Highset 1Setting</b>	OFF, 0.05, 0.10...3.00, 3.5, 4.0... <b>10.0</b> ...52.5	xln	<i>see note 1 below</i>

Setting name	Range ( <b>bold = default</b> )	Units	Notes
Gn P/F [E/F] Highset 1 Delay	<b>0.00</b> , 0.01...20.00, 20.5 ...100, 101 ... 300	sec	
Gn P/F [E/F] Highset 2 Dir Control	<b>OFF</b> , FWD, REV, TRI		<i>Argus 2 and Argus 6 only.</i>
Gn P/F [E/F] Highset 2 Setting	<b>OFF</b> , 0.05, 0.1...3.00, 3.5, 4.0...52.5	xIn	<i>see note 1 below</i>
Gn P/F [E/F] Highset 2 Delay	<b>0.00</b> , 0.01...20.00, 20.5 ...100, 101 ... 300	sec	

Sub-menu: **O/P Relay Config.**

Setting name	Range ( <b>bold = default</b> )	Units	Notes
Gn P/F [E/F] Starter	_, 1 for each output contact (default: _____)		<i>see note 1 below</i>
Gn P/F [E/F] Charact. Gn P/F [E/F] Lowset Gn P/F [E/F] Highset 1 Gn P/F [E/F] Highset 2	_, 1 for each output relay R1 – R11 (default: <b>1</b> _____)		<i>default settings - all protections energise output relay 2</i>

Sub-menu: **Status Config.**

Setting name	Range ( <b>bold = default</b> )	Units	Notes
Gn P/F [E/F] Charact. Inhib. Gn P/F [E/F] Lowset Inhib. Gn P/F [E/F] Highset 1 Inhib. Gn P/F [E/F] Highset 2 Inhib.	_, 1 for each status input S1 – S11 and Vstart (default: _____)		<i>Argus 2 type II relays only, each element can be set to be inhibited from the voltage element starter.</i>

Note 1. If the directional control is set to tri-state, these settings will be duplicated for forward and reverse directions. The settings for the forward direction are indicated by an 'F' following the group number (e.g. GnF P/F Charact.), while the settings for the reverse direction are indicated by an 'R' (e.g. GnR P/F Charact.).

Note 2. The above table shows the settings for phase-fault elements, with the text for earth-fault indicated by square brackets, e.g. Protection:Gn P/F Charact. Dir Control becomes Protection:Gn E/F Charact. Dir Control.

### 2.3.3 Flashing (Pecking) Fault Protection

Flashing Faults are characterised by a series of short pulses of fault current which are intermittent, if the IDMT/DTL element characteristic has an instantaneous reset then it may not operate. In order to detect and operate for such faults the relay has a setting that enables the user to set the Protection:Relay Reset Delay. This setting modifies the reset-mode of the IDMT/DTL protection algorithm such that after the fault current has disappeared the current time totals are held. For faults that re-appear within the Relay Reset Delay time the current-time integration continues from the last value reached. Where the fault current does not reappear within the Relay Reset Delay time then the integrator will reset to zero and any subsequent fault will start a new integration of current-time. Thus for flashing faults where the fault current pulses reappear within the set reset time, up to 60 seconds after the end of the last pulse, the delayed characteristic will operate on the summation of the fault current-time.

Where auto-reclose is not required after a delay protection trip i.e. sequence = 2I + 1D, then the Relay Reset-Delay time setting should be set to 60sec. Where a delay protection trip is to be followed by auto-reclose + delay protection then this setting may be left at the default value of instantaneous or set to a time which is less than the reclose delay between consecutive delay protection operations. Setting times as above will provide flashing fault coverage and still allow grading between relays in series on the system.

If this function is not required the Relay Reset Delay time can be set to 'INST'.

**Table 2-12 Flashing Fault Setting**

Sub-menu: **Protection**

Setting name	Range ( <b>bold = default</b> )	Units	Notes
Gn Relay Reset Delay	<b>INST</b> , 1,2...60	sec	

## 2.4 Sensitive Earth-fault and Restricted Earth-fault

This element can be used for either sensitive earth-fault or high-impedance restricted earth-fault protection schemes. The two applications are not possible simultaneously – the user must select which is required. The restricted earth-fault scheme is described in section 2.4.1 below.

The element includes a software filter for rejection of second, third and higher harmonics of the power system frequency. The instantaneous element, set using *Protection:SEF/REF Current Setting*, provides a starter output. Two sequential DTL follower timers (*Protection:SEF/REF 1st Time Delay* and *Protection:SEF/REF 2nd Time Delay*) plus an additional timer (*Protection:SEF/REF Lowset Delay*) are provided; all use the same *Protection:SEF/REF Current Setting*. The delayed reset function (section 2.3.3) is applied on each of the two DTL timers.

Each of the three timing elements has an output, mapped by a setting. Each timing element can be inhibited from a status input, mapped by a setting, see Figure 2.4-1.

In multi-pole directional Argus models the SEF element is non-directional. In single-pole directional SEF models the directional control setting applies to all the SEF Protection elements.

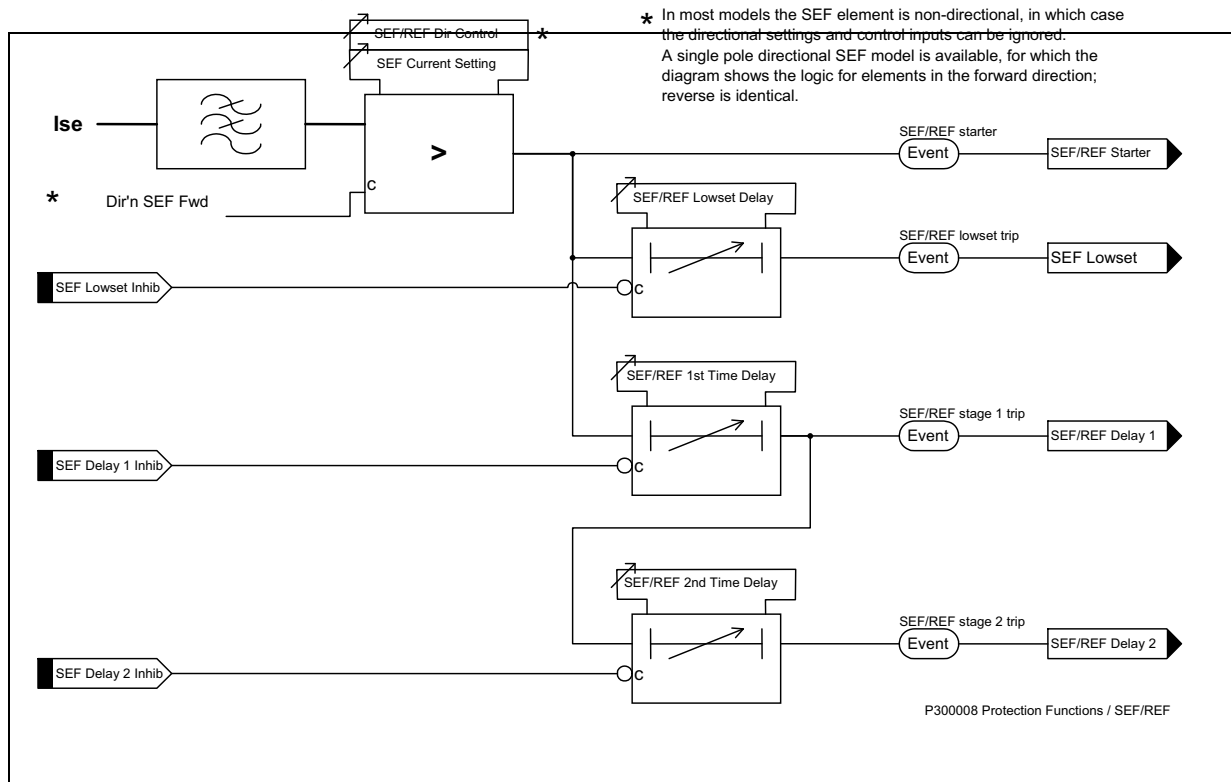


Figure 2.4-1 Functional Diagram – Sensitive Earth-fault/Restricted Earth-fault Elements

Table 2-13 Sensitive Earth-fault / Restricted Earth-fault Settings

Sub-menu: **Protection**

Setting name	Range ( <b>bold = default</b> )	Units	Notes
Gn SEF Dir Control	<b>OFF</b> , FWD, REV, TRI		Argus 2 Single-pole dir'n. SEF only.
Gn SEF/REF Current Setting	0.005, 0.010... <b>0.050</b> ...0.960	xIn	see note 1 below
Gn SEF/REF 1st Time Delay	0.00, 0.01... <b>5.00</b> ...20.00, 20.5 ...100, 101 ... 300 s	sec	
Gn SEF/REF 2nd Time Delay	OFF, 0.00, 0.01... <b>5.00</b> ...20.00, 20.5 ...100, 101 ... 300 s	sec	
Gn SEF/REF Lowset Delay	<b>0.00</b> , 0.01...20.00, 20.5 ...100, 101 ... 300 s	sec	

Sub-menu: **O/P Relay Config.**

Setting name	Range ( <b>bold = default</b> )	Units	Notes – see note 1 below

Setting name	Range ( <b>bold = default</b> )	Units	Notes – see note 1 below
<b>Gn SEF/REF Starter</b>	<b>_</b> , 1 for each output contact (default: _____ )		
<b>Gn SEF/REF Delay 1</b> <b>Gn SEF/REF Delay 2</b> <b>Gn SEF/REF Lowset</b> <b>GnF SEF/REF Block</b> <b>GnR SEF/REF Block</b>	<b>_</b> , 1 for each output contact (default: <b>_ 1</b> _____ )		<i>see note 1 below</i> <i>default settings – all Protection elements energise the Trip output relay 2.</i>

Sub-menu: **Status Config.**

Setting name	Range ( <b>bold = default</b> )	Units	Notes
<b>Gn SEF/REF Delay 1 Inhib.</b> <b>Gn SEF/REF Delay 2 Inhib.</b> <b>Gn SEF/REF Lowset Inhib.</b>	<b>_</b> , 1 for each status input (default: _____ )		

Note 1. On the single-pole directional SEF model, if the directional control is set to tri-state these settings will be duplicated for forward and reverse directions. The settings for the forward direction are indicated by an 'F' following the group number (e.g. GnF\_SEF\_Current\_Setting), while the settings for the reverse direction are indicated by an 'R' (e.g. GnR\_SEF\_Current\_Setting).

## 2.4.1 High Impedance Restricted Earth-fault Scheme

Externally mounted power resistors, connected in series with the relay, are required to set the stability voltage  $V_S$ . See Section 3: Application Notes for the theory and formulae required to calculate the  $I_S$  and  $V_S$  settings and resistor values. A non-linear resistor may also be required to protect the scheme wiring and current transformers against transient over-voltages at high fault levels.

## 2.5 Primary Equipment Fail Protection

### 2.5.1 Circuit Breaker (Trip) Fail Protection

Provides 50CBF Trip Fail two-stage time delay with Phase, Earth and SEF current level detectors.

If the Circuit Breaker (CB) fails to respond to a Trip output and fault current continues to flow, then the ARGUS Circuit Breaker Fail (CBF) function can be set to automatically issue a graded, time-delayed, CBF 1 output (Re-trip) then, if that fails, a second CBF 2 output (Back Trip to an up-stream CB).

Any Protection element or Status input for which a Trip output is required must be mapped to an output relay which in turn is mapped to 'Fault Trigger'. When 'Fault Trigger' is raised this enables the CBF current level detectors that check for cessation of current flow in each pole. If and while any current exceeds setting, specified by Protection:P/F CB Fail Setting, Protection:E/F CB Fail Setting or Protection:SEF CB Fail Setting, then CBF Time delay 1 timer, specified by Protection:CB Fail Time Delay 1, runs. On time-out the CB Fail 1 output is raised, this can be mapped to another output relay to provide a re-trip output.

A second CBF timer, specified by Protection:CB Fail Time Delay 2, then starts and runs if and while current exceeds setting. On time-out CB Fail 2 output is raised, this can be mapped to a different output relay to provide a Back-trip output.

NB:- If CBF is to be applied then a current setting should be entered for all poles i.e. P/F & E/F & SEF settings. Typical settings will be below the protection settings applicable for each pole; phase fault setting can normally be above maximum Load current. The CBF scheme will then run until all currents fall below the set detector levels. If any CBF current setting is set to OFF i.e. Zero current, then, once enabled, the CBF function will run until all currents are zero. Grading time margins and settings will be typically 200ms for CB Fail Time delay 1, and 200ms for CB Fail Time delay 2.

If CBF is not required then CBF Time delay 1 and CBF Time delay 2 should be set to OFF i.e. Infinity.

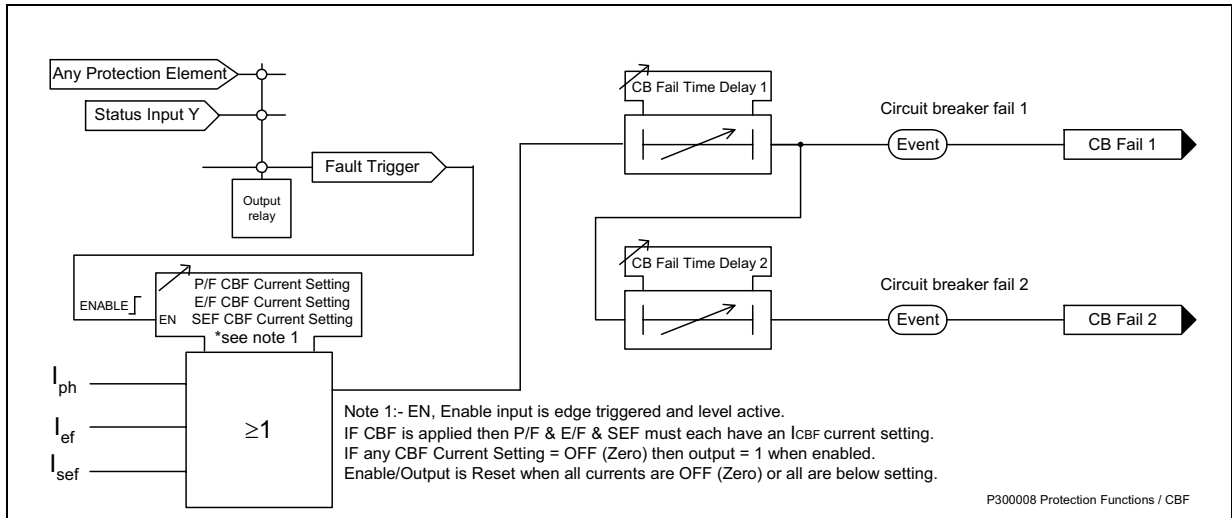


Figure 2.5-1 Functional Diagram – Circuit Breaker Fail

Table 2-14 Circuit Breaker Fail Settings

Sub-menu: **Protection**

Setting name	Range ( <b>bold = default</b> )	Units	Notes
Gn P/F CB Fail Setting	<b>OFF</b> , 0.05, 0.1 ... 1.00	xIn	
Gn E/F CB Fail Setting	<b>OFF</b> , 0.05, 0.1 ... 1.00	xIn	
Gn SEF CB Fail Setting	<b>OFF</b> , 0.005 ... 0.96	xIn	
Gn CB Fail Time Delay 1	<b>OFF</b> , 0.00, 0.01...20.00, 20.5	sec	
Gn CB Fail Time Delay 2	...100, 101 ... 300 s		

Sub-menu: **O/P Relay Config.**

Setting name	Range ( <b>bold = default</b> )	Units	Notes
Gn CB Fail 1	<b>1</b> , 1 for each output contact		
Gn CB Fail 2	(default: _____)		

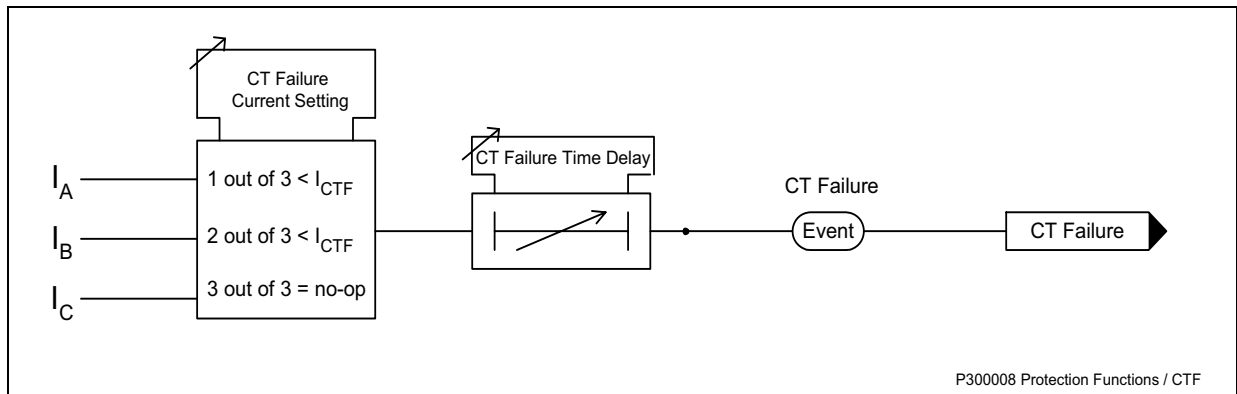
### 2.5.2 Close Fail

Argus 4 and Argus 6 only

Circuit breaker close operation is also monitored. The relay checks the status of the CB at the end of each close pulse. If the CB has not closed then the relay locks out due to CB close fail, and any sequence is terminated.

### 2.5.3 Current Transformer Failure

The current flowing from each of the Phase Current Transformers is monitored. If one or two of the three input currents falls below the CT Supervision current setting for more than the CT Failure time delay then CT Failure is raised. If all three input currents fall below the setting CT Failure is not raised.



**Figure 2.5-2 Functional Diagram – Current Transformer Fail**

**Table 2-15 Current Transformer Fail Settings**

Sub-menu: **Protection**

Setting name	Range ( <b>bold = default</b> )	Units	Notes
<b>Gn CT Failure Setting</b>	<b>OFF</b> , 0.05, 0.1 ... 1.00	xIn	
<b>Gn CT Failure Delay</b>	<b>OFF</b> , 0.00, 0.01...20.00, 20.5 ...100, 101 ... 300 s	sec	

Sub-menu: **O/P Relay Config.**

Setting name	Range ( <b>bold = default</b> )	Units	Notes
<b>Gn CT Failure</b>	<b>_</b> , 1 for each output contact (default: _____)		

## 2.5.4 Trip Circuit Supervision - for details see sections 2.10 and 3.8

## 2.6 Cold Load Protection

*Argus 4 and Argus 6 only*

A cold load protection function is provided to cater for closing onto the type of load that, after being de-energised for some time, on energisation takes a high level of current for an extended period.

The System Config.:Cold Load Pickup Group setting allows the user to select the setting group number to which the relay will switch after the circuit breaker has been open for longer than the user-set Auto-reclose: Cold Load Enable time. This cold load group's overcurrent settings will normally be set higher and the time characteristics will be set slower than the normally-active group's settings. The relay will switch to the nominated cold load group n and then when the circuit breaker is closed will apply that group's overcurrent and auto-reclose settings until the user-set Autoreclose: Cold Load Reset time expires, then revert to the normally-active group.

The Relay can be set up to revert to the normally active group sooner if the load current falls and remains below the cold load group's Protection:P/F Highset 2 Setting for longer than the Protection:P/F Highset 2 Delay timer. Phase-fault highset 2 in the set cold load group operates as an under-current element. This element's setting should be set, 5% or more, below the normally-active group's phase-fault overcurrent element settings. This prevents the relay from changing back, from the cold load group to the normally active group, before the cold load inrush current has fallen below the normally active group's P/F starter settings, so that when the relay reverts to the normally-active group settings the relay does not then operate and give a trip output. The cold load group's phase-fault highset 2 element will be picked up during cold load inrush conditions and should not be user mapped to the trip relay.

Selecting the cold load group's Phase Fault highset 2 to OFF will de-select this fast revert mode, reversion will then only occur at the end of the cold load reset delay.

At the end of the cold load reset delay, if the current is still above the HS2 setting, or any starter is picked up, the relay will issue a trip and lockout. It will then revert to the normally-active group settings.

Automatic cold load pick-up can be disabled by setting the Auto-reclose: Cold Load Enable time delay to OFF. This still allows Cold Load Group n to be selected via a mapped Status Input.



**Table 2-16 Cold Load Pickup Settings**Sub-menu: **System Config.**

Setting name	Range ( <b>bold = default</b> )	Units	Notes
<b>Cold Load Pickup Group</b>	1,2... <b>8</b>		

Sub-menu: **Auto-reclose**

Setting name	Range ( <b>bold = default</b> )	Units	Notes
<b>Cold Load Enable</b>	<b>OFF</b> , 0.20...2.0, 2.1...20, 21...300, 360...3600, 3900...14400	sec	
<b>Cold Load Reset</b>	0.20...2.0, 2.1...20, 21...300, 360... <b>600</b> ...3600, 3900...14400	sec	

## 2.7 Directional Control

*Argus 2 and Argus 6 only*

Each phase-fault and earth-fault delay characteristic, lowset and highset elements can be independently programmed to non-directional, forward directional, reverse directional or bi-directional (tri-state) operation. The SEF/REF element on most Argus 2 and Argus 6 models is not normally directional, however, a single-pole directional SEF model is available.

Figure 1.5-7 illustrates the directional operating characteristic relative to the characteristic angle (CA), historically known as the maximum torque angle. This is the phase angle of the fault current relative to the polarising voltage reference for which the directional detector gives maximum sensitivity in the forward operate zone. The reverse operate zone is an exact mirror image of the forward zone. The directional element is referred to as 'tri-state' because conditions will occur for which neither the forward nor the reverse element should operate.

If a protection element is programmed by the user to be non-directional then only non-directional overcurrent settings will be presented. The element will operate independently of the output of the directional detector and operation will occur for current above setting regardless of phase angle.

If a protection element is programmed for forward directional mode then the forward zone overcurrent settings will be presented and operation will only occur for fault current falling within the forward operate zone. Conversely, if a protection element is programmed for reverse directional mode then the reverse zone overcurrent settings will be presented and operation will only occur for fault current falling within the reverse operate zone.

Where the tri-state option is selected an element will operate for fault current above its setting in either direction. Different overcurrent settings can be programmed for forward and reverse operation. In addition, the forward and reverse trip output signals can be issued to different output contacts.

Directional relays can be applied to directional blocking schemes. Both phase and/or earth fault blocking outputs can be generated for forward or for reverse direction faults, e.g. `Protection:P/F FWD Block` specifies relays which will operate for a phase-fault in the forward direction.

Blocking inputs can be received via the status inputs, each of which can be programmed to inhibit operation of any overcurrent protection element - see section 2.2.

### 2.7.1 Polarisation

#### Phase-fault

Voltage polarisation is achieved for the phase-fault elements using the quadrature voltage whereby each phase current is compared to the voltage between the other two phases, i.e.

$$I_A \sim V_{BC} \quad I_B \sim V_{CA} \quad I_C \sim V_{AB}$$

Two types of directional element exist, referred to here as type I and type II. On a relay with type I directional elements the phase-fault characteristic angles can be user programmed to either +30° or +45° using the `Protection:P/F Charact Angle` setting. On a relay with type II elements, any characteristic angle between -90° and +90° can be selected. The characteristic angle setting should be matched to the approximate expected nominal angle of system fault, i.e. the source impedance angle.

#### Earth-fault

Voltage polarisation is also used for earth fault elements, comparing the earth fault current  $I_e$  ( $3I_0$ ) against the system residual voltage  $V_n$  ( $3V_0$ ).

In relays with type I directional elements the residual voltage is obtained from the open delta connection of the tertiary windings of the line-N voltage transformers. The earth-fault characteristic angles can be user programmed to **0°**, **-15°**, **-45°** or **-65°** using the Protection:E/F Charact Angle setting.

In relays with type II directional elements an open delta tertiary winding can be used or alternatively the relay will itself calculate the residual voltage internally from the three applied phase-earth voltages. With these relays any characteristic angle between -90° and +90° can be selected. The characteristic angle setting should be matched to the expected nominal angle of system fault.

Note that when type I directional Argus relays are used on 60Hz systems the nominal characteristic angles will change slightly, typically P/F by less than +5° and E/F by less than -5°.

### 2.7.2 Two-out-of-three Gate

This feature is applicable to relays with three directional phase-fault poles. It provides the means of achieving absolute discrimination, between two directional overcurrent protection relays, in power system applications where +1 : -2 : +1 fault current distribution can occur.

When the Directional:2-Out-Of-3 Gate Logic setting is set to ON, the directional elements will only operate for the majority direction, e.g. if phase A and C detect forward current flow and phase B detects reverse current flow, phase A and C will operate forwards, while phase B will be inhibited.

### 2.7.3 Voltage Memory

In the condition of a 3 phase fault where the polarising voltage collapses the relay can maintain the Forward or Reverse direction for each pole for up to 0.5 s. The Directional:Voltage Memory setting is used to set the amount of time the relay will hold the memory of the direction.

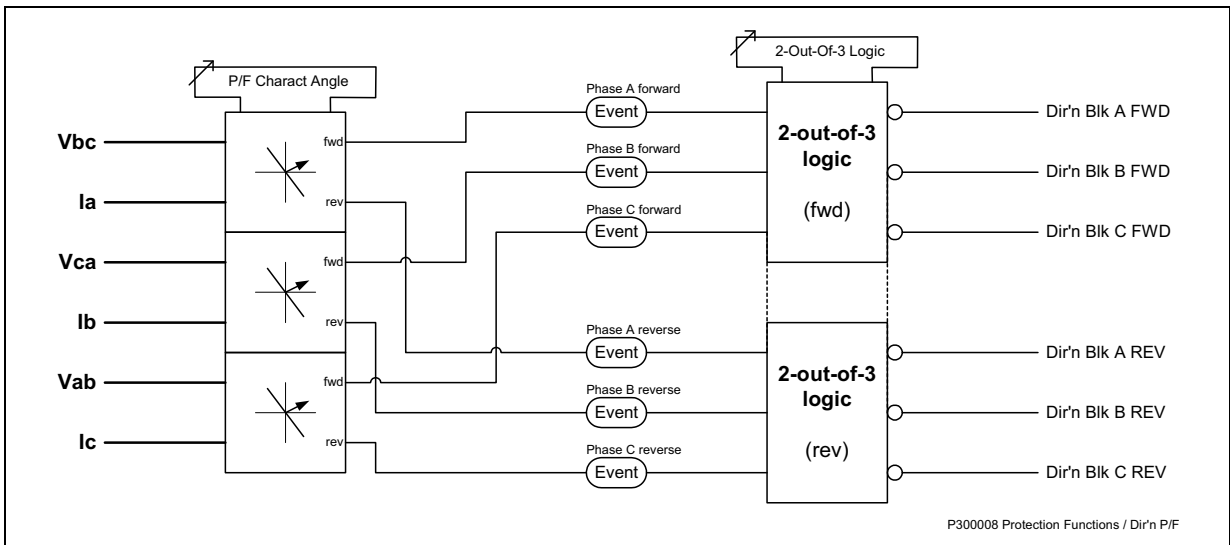


Figure 2.7-1 Functional Diagram – Phase-fault Directional Element

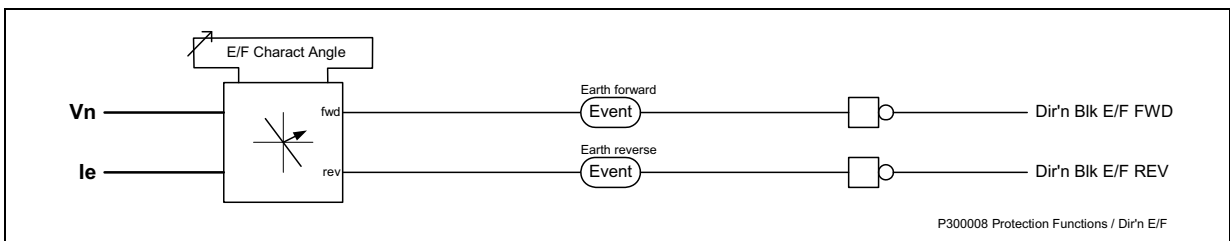


Figure 2.7-2 Functional Diagram – Earth-fault Directional Element

Table 2-17 Directional Settings

Sub-menu: **Directional**

Setting name	Range ( <b>bold = default</b> )	Units	Notes
--------------	---------------------------------	-------	-------

Setting name	Range ( <b>bold</b> = default)	Units	Notes
<b>2-Out-Of-3 Gate Logic</b>	<b>OFF</b> , ON		
<b>P/F Charact Angle</b>	+30, <b>+45</b>	°	Type I element.
	-90, -89... <b>+45</b> ...+90	°	Type II element.
<b>E/F Charact Angle</b>	0, <b>-15</b> , -45, -65	°	Type I element.
	-90, -89... <b>-15</b> ...+90	°	Type II element.
<b>SEF Charact Angle</b>	0, <b>-15</b> , -45, -65	°	Type 1 only
<b>Voltage Memory</b>	OFF, 0.1 ... 0.5	sec	

Sub-menu: **O/P Relay Config.**

Setting name	Range ( <b>bold</b> = default)	Units	Notes
<b>Gn P/F FWD Block</b> <b>Gn P/F REV Block</b> <b>Gn E/F FWD Block</b> <b>Gn E/F REV Block</b>	_, 1 for each output contact (default: _____)		
<b>Gn SEF FWD Block</b> <b>Gn SEF REV Block</b>	_, 1 for each output contact (default: _____)		Argus 2 single-pole directional SEF only.

## 2.8 Voltage Protection

Argus 2 (type II) models only

A single three-phase voltage element with definite time delay is provided. The Voltage:V.Operation setting allows the element to be set for overvoltage or undervoltage operation. When set to undervoltage an additional blocking threshold (Voltage:V.Block.Threshold) prevents inadvertent operation when the system is de-energised.

An instantaneous output is driven from the level detector (Voltage:V.Ph-Ph.Setting)/(Voltage:V.Ph-N.Setting), with a follower definite time delay Voltage:V.Delay driving the Voltage:V.Trip output. These outputs can be set by the Voltage:V.Q/P.Phases setting to operate from any phase operation, or only when all phase elements operate.

The Voltage:V.Hysteresis setting specifies the percentage above or beneath the (Voltage:V.Ph-Ph.Setting)/(Voltage:V.Ph-N.Setting), setting at which the element resets. For example, an element with Voltage:V.Operation set to Overvoltage, Voltage:V.Setting of 100 V and Voltage:V.Hysteresis of 1 % will nominally operate above 100 V and reset below 99 V. If Voltage:V.Operation is set to Undervoltage, the element will operate below 100 V and reset above 101 V.

The voltage elements are set in terms of the directly measured voltage. If used for phase-phase connection the voltage elements will be phase-phase; if used for phase-neutral connection the voltage elements will be phase-neutral.

The voltage elements provide pole-by-pole outputs that can be used to block the appropriate overcurrent element using the Status.Config.:P/F.xxx.Inhibit settings. Note that if used with phase-phase connection of the voltage inputs, the Vab element will block the phase A overcurrent element, Vbc will block phase B overcurrent and Vca will block phase C overcurrent.

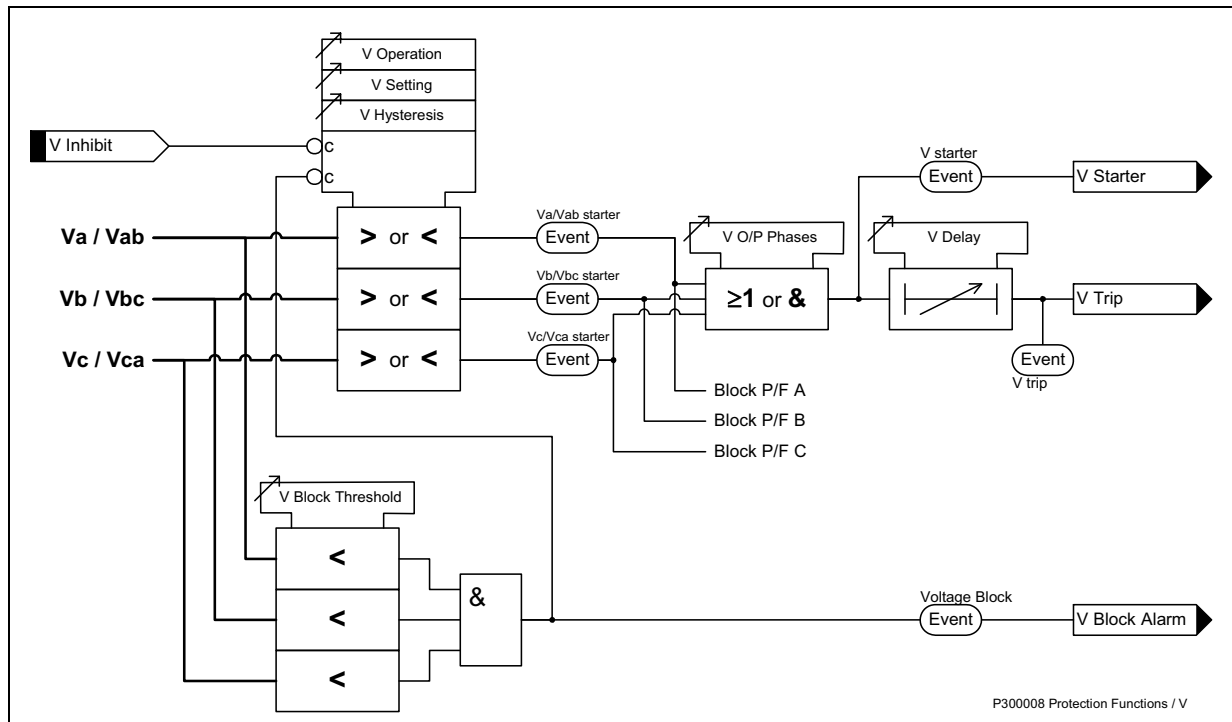


Figure 2.8-1 Functional Diagram – Undervoltage/Overvoltage Element

Table 2-18 Voltage Protection Settings

Sub-menu: **Voltage**

Setting name	Range ( <b>bold = default</b> )	Units	Notes
<b>Gn V Operation</b>	<b>OFF</b> , O/V, U/V		
<b>Gn V Setting (Ph-N)</b> <b>Gn V Setting (Ph-Ph)</b>	5.0, 5.5... <b>80.0</b> ...200.0	V	Setting indicates whether phase-phase or phase-neutral is in use – set by <u>System Config.:VT Connection</u>
<b>Gn V Delay</b>	<b>0.00</b> , 0.01...20,20.5... 100.0,101.0...600.0	sec	
<b>Gn V Hysteresis</b>	1,2...90	%	
<b>Gn V Block Threshold</b>	OFF,1,2... <b>5</b> ...100	V	
<b>Gn V O/P Phases</b>	<b>Any One</b> , All		

Sub-menu: **O/P Relay Config.**

Setting name	Range ( <b>bold = default</b> )	Units	Notes
<b>Gn V Starter</b> <b>Gn V Trip</b> <b>Gn V Block Alarm</b>	_, 1 for each output contact (default: _____)		

Sub-menu: **Status Config.**

Setting name	Range ( <b>bold = default</b> )	Units	Notes
<b>Gn V Inhibit</b>	_, 1 for each status input (default: _____)		

## 2.9 Auto-Reclose

Argus 4 and Argus 6 only.

Approximately 90% of all overhead line faults are transient (non-damage) arcing Phase(s) to Earth faults induced by lightning or due to other transient initiation. Use of a sequence of Instantaneous (Lowset) trips followed by Delayed trips e.g. 2I + 1D with line Dead-Times (Reclose Delays) ensures that such transient faults are cleared quickly before consequential permanent damage to the plant can occur and hence, after the line has been dead for a short time (1 – 5 s) to allow arc by-products and ionised air to disperse, the healthy line can be reclosed and

the system restored. The Delay trips ensure that, if the instantaneous trips do not clear the fault i.e. it is permanent, grading of the protections in series on the system occurs and the protection closest to the fault will trip and isolate the fault.

## 2.9.1 Auto Reclose Sequences

The AUTO\_RECLOUSE\_MENU enables the user to programme independent auto-reclose sequences for phase-fault, earth-fault, sensitive earth-fault, and/or auto-reclose initiation from an external protection trip via a status input mapped to STATUS\_CONFIG:ARC\_Status\_A (SA). For each sequence the user can select the optimum sequence settings i.e. each trip can be selected to be either INSTantaneous or DELAYed with different Dead Times before Reclosure for each shot. The User can set the required Sequence and number of Instantaneous trips and Delayed trips to LockOut, the number of shots (Recloses) to LockOut, the number of High Set 1 Instantaneous trips to LockOut and the number of High Set 2 trips to LockOut, allowed to achieve maximum retention/availability of the power system. After each trip the relay determines its next course of action using the User settings. The correct Auto-Reclose delay and Protection Characteristic response is applied after each trip in response to the type of fault cleared, thus the correct sequence is applied at each stage of a developing fault.

Note:- in the AUTO\_RECLOUSE:P/F\_Protection\_Trip: settings, INST refers to Instantaneous LowSet and not to instantaneous HighSet. Also all protection elements operate in parallel, therefore, the first non-inhibited element, that is mapped to trip, to time out will generate a trip output. The Delay and HighSet elements 1 & 2 can be used together to provide a composite characteristic with IDMTL/DTL operation at low fault levels and higher speed operation at higher fault levels to grade with fuses etc.

Sequence Co-ordination of the Instantaneous (Lowset) and Delayed protection operation of two relays in series on a feeder is automatically provided if the upstream Lowset Instantaneous has a grading delay set. Grading between both relays' Lowsets will be maintained and both upstream and downstream protections will keep their shot counters in-step throughout a sequence; the upstream protection will apply the same sequence of INST/DELAY protection, grading with the downstream CB on each shot and not tripping, thus the downstream CB performs all the necessary trips to clear the fault.

To monitor the Circuit Breaker position the relay uses two Status inputs, mapped to the STATUS\_CONFIG:CB\_Open and STATUS\_CONFIG:CB\_Closed settings, and Fault current monitoring to determine if the circuit breaker is open or closed. If the CB is closed, or its state indeterminate due to interlock failure producing conflicting inputs, a reclose Close pulse output will be inhibited, but a Manual Close & Reclaim or Remote Close & Reclaim Close pulse output is always allowed.

The AUTO-RECLOUSE:P/F ARC, AUTO-RECLOUSE:E/F ARC, AUTO-RECLOUSE:SEF ARC and AUTO-RECLOUSE:SA ARC - IN/OUT settings enable auto-reclose to be independently selected ON or OFF for each fault type. When ARC is set to IN (On) i.e. switched into service, each setting can be overridden to OUT (Off) via a raised mapped status input STATUS\_CONFIG:P/F ARC Off etc., or by being set to Off via the communications link commands. Overall All ARC On/Off may also be set via the Relay's Linesman\_Mode:ARC\_ON/OFF setting (see section 2.14.2) or via a communications link AutoReclose OFF command.

At significant stage points during an auto reclose sequence the relay logs and sends named events via the communications link, with raised or cleared status as applicable. These named events greatly assist the user in the process of determining the timing and exact sequence of events and the relay's response to system fault conditions. The relay also indicates the status and progress of the auto reclose sequence via its ARC Status and ARC Inhibits Instruments.

### 2.9.1.1 Protection and Auto Reclose Sequences

The following clauses describe the functionality of each setting in the Auto Reclose Menu for the Phase Fault sequence. Identical settings and comments apply to the Earth Fault, Sensitive Earth Fault, and External Arc Start via Status ARC start (SA) sequences. Each Settings Group G1, G2...G8 can have different Auto Reclose sequence settings, or none, applied by the User.

#### **Gn Line Check Trip = ON/OFF**

The Auto-reclose:Line Check Trip setting allows this function to be enabled (ON) or dis-enabled (OFF) and is applied to all Groups (G1 to G8) and all Sequences i.e. P/F, E/F, SEF & SA.

With Auto-reclose:Line Check Trip = ON, if the circuit breaker is closed via a Close pulse from the relay in response to a raised 'Local Close & Reclaim' or a 'Remote Close & Reclaim' command raised via a mapped status input, or communications command, or from the Linesman menu Linesman\_Mode:Close & Reclaim (section 2.14.2); then the Line Check Trip (switch on to fault) function is activated and remains activated until the Reclaim Timer resets.

The Line Check function ensures that if the circuit breaker is closed onto a permanent fault, or if the circuit breaker closes onto a healthy line but a fault then develops within the Auto-reclose:Reclaim Time setting, that the relay will perform only one trip to Lockout, The relay will trip but it will not reclose nor go through an auto reclose sequence.

The protection applied for Line Check Trip can be set independently for P/F, E/F, SEF/REF and/or SA, to either INST (Instantaneous Lowset) or to DELAYED (Delayed + HS1 + HS2), by the relevant Auto-reclose:Line Check Trip settings.

An example of this setting's use is that after a lockout state is reached the user can set Line Check Trip to OFF so that when the Circuit Breaker is then manually closed onto a permanent fault the relay is forced to go through an auto reclosing sequence to ensure that sectionalising/grading occurs to isolate a permanently faulted section of the system. After successful isolation Auto-reclose:Line Check Trip should be set back to ON.

### **P/F ARC = IN/OUT**

Auto-reclose:P/F ARC setting,

If set to IN (on) the relay will perform a full Phase Fault AutoReclose sequence,

If set to OUT (off) the relay will perform a one Trip to Lockout sequence applying the first programmed protection trip characteristic unless this is overridden by any applied inhibit controls.

The first protection trip characteristic in a sequence will typically be set to INST i.e. Instantaneous Lowset, therefore, if P/F ARC is set to OUT (off) the relay will not grade with other Protections in the system to isolate a permanent fault. However, the relay can be re-configured to perform one delayed Trip to Lockout by raising P/F Lowset Inhib., preventing the Instantaneous Lowset from operating, thus allowing the IDMT Characteristic etc. to grade.

P/F Lowset can be Inhibited by a raised status input mapped in Status Config:P/F Lowset Inhib., or P/F INST ON/OFF can be set via the communications link commands. All Inst. Lowset ON/OFF may also be set via the relay's Linesman Mode:Inst. Lowset ON/OFF setting (see section 2.15) or via a communications link P/F Instantaneous ON/OFF command.

### **Protection Trips 1 to 4**

The Protection characteristic applied for each of the first four trips in a sequence can be user set to INST Instantaneous (LowSet) or composite delayed + HighSet1 + HighSet2 characteristic, as specified by the Auto-reclose:P/F Protection Trip 1.(2)(3)(4) settings. Any combination of inst (I) & Delayed (D) trips is allowed e.g. 2I + 2D, or I+D+I+D, or 2D + 2I etc.. However, the fifth trip in any sequence, if allowed by the user, will always apply the composite delayed + HS1 + HS2 characteristic to attempt to retain as much of the system in service as possible.

The two highset elements can be applied as trip elements with the delayed characteristic to provide a composite characteristic, or used as independent elements. The Auto-reclose:P/F HS1 Trips To Lockout and Auto-reclose:P/F HS2 Trips To Lockout settings may be set to limit the number of high current trips, or, if set to 1 to truncate a P/F sequence to Lockout if the HS1 or HS2 fault level setting is exceeded.

### **Reclose Delay (Dead time) and Close Routine**

The Reclose delay or line Dead Time, is basically the length of time the Circuit Breaker is open before being reclosed. An auto reclose sequence may have more than one Reclose delay.

After the first and subsequent trips, when the Circuit Breaker has opened and all starters and External ARC Start SA are cleared, the relay checks the reason for that Trip and determines its next state.

If the relay determines that it is not to go to Lockout but is to proceed to perform the next set step in the Auto-Reclose sequence, the relay applies the Reclose Delay (dead time) specified by the Auto-reclose:P/F Reclose DTL [1][2][3][4] settings, the Auto Reclose sequence commences and an 'Arc Active' event and alarm is raised, this may be mapped by the user to an output relay as defined by the O/P Relay Config:ARC Active setting. The output remains raised until the sequence has successfully reclaimed, or a lockout occurs, at which time the 'Arc Active' event and alarm output is cleared.

After the Reclose Delay the relay enters the Reclose routine and checks that Reclose Block is not raised before issuing a close pulse via the output relay output contacts specified by the O/P Relay Config.:Close Pulse setting. Note: If any ARC INHIBIT is raised before or at any time during a Reclose Delay or during the Reclose Block time the relay will go to Lockout.

A raised status input mapped to Status Config:Reclose Block can be used to prevent autoreclosing if external conditions do not allow an immediate close of the circuit breaker e.g. if a motor wound circuit breaker close spring needs additional time to recharge or if the system is out of synchronism, etc. External blocking contacts can be wired in parallel. If all the reclose block inputs are not cleared within the 5 second reclose-block time delay the relay will go to Lockout. If all the reclose block inputs are cleared at any time within the 5 secs reclose-block time delay then the close pulse will be issued, thus the autoreclose close pulse may be held back by up to 5 secs after the end of the reclose delay.

The Close Pulse duration is set using the Auto-reclose:Close Pulse setting. The close pulse will be truncated either when the Status Config:CB Open and Status Config:CB Closed status inputs show that the CB has closed, or if the CB closes onto a fault and any protection starter picks up. Thus the close pulse may be left set to the default of 2 seconds without racing conflicts being created. The relay will not issue a Close pulse to a closed CB.

The relay also provides an Auxiliary Close output that can be mapped to an output relay by O/P Relay Config.:AUX Close which will be energised for 200 ms before the end of the close pulse. This output can be used to energise an external relay with a heavy duty break contact, connected in series with the close coil of the CB, to prevent output contact damage for a stuck circuit breaker condition. It can replace the anti-pumping timer.

If at the end of the close pulse the circuit breaker has not closed, then the relay will raise a CB FAIL alarm then Lockout (section 2.5.2). If at the end of the close pulse, the circuit breaker has successfully closed then the relay will start the Reclaim Delay timer.

### Reclaim

After the Circuit Breaker has been successfully reclosed the relay goes into the Reclaim state for the duration of the Reclaim delay, set by the Auto-reclose:Reclaim Time setting.

If within the Reclaim Delay a new fault occurs and a protection starter picks up, or if an external Arc Start SA input is raised, then the relay will continue the existing Protection/Auto reclose sequence as programmed.

If within the final Reclaim Delay a new fault occurs and a protection starter picks up, or if an external Arc Start SA input is raised, then the relay will apply the programmed last shot Protection characteristic, if any protection element operates a trip output will be issued then the relay will go to Lockout.

If the Reclaim Delay times out without another fault occurring then the relay will Reclaim i.e. reset, the sequence shot counter will be reset to zero and any subsequent fault will start a full new sequence.

At the start of a Reclaim Delay a 'Reclaim raised' event is generated. At the end of a successful Reclaim Delay a 'Reclaimed cleared' event is issued and an output is raised, this may be mapped by the user to any output relay using the O/P Relay Config.:Reclaimed setting.

### Lockout

Lockout is a state where the relay truncates the current sequence or operation and resets leaving the Circuit Breaker Open and no further action is taken. The relay goes to the Lockout state when it reaches the last trip of a sequence without being able to clear a permanent fault or if conditions are such that a sequence or operation is truncated without completion. It is not necessary to reset the relay's Lockout state to be able to close the circuit breaker.

The number of Reclose attempts in any sequence before the relay locks out can be set by the User by the Auto-reclose:P/F Shots To Lockout setting. A sequence of up to four Close shots (five Trips) to Lockout may be set by the User. When Lockout is reached a Lockout event is issued and an output is raised as defined by the O/P Relay Config.:Lockout Alarm setting.

The Auto-reclose:LO Recovery delay inhibits all Close & Reclaim commands, from a status input or communications command, for a set time delay after lockout. The delay can be user selected to OFF, or to a set time delay. If set the delay prevents an operator from repeatedly quickly closing onto a permanent fault, allowing the Plant to cool between closes preventing overheating / overstressing.

**Table 2-19 Auto-reclose from Internal Elements - Settings**

Sub-menu: **Auto-reclose**

Setting name	Range ( <b>bold</b> = default)	Units	Notes
<b>Gn Line Check Trip</b>	<b>ON, OFF</b>		<i>Common setting, applies to all Sequences in that group</i>
<b>Gn Seq Edit/View</b>	'ALL', 'P/F Sequence', 'E/F Sequence', 'SEF/REF Sequence', 'SA Sequence'		<i>The settings below relating to P/F are repeated for E/F and SEF. This setting allows the user to display a subset of them only. Default depends on relay type. 'ALL' shows all settings</i>
<b>Gn P/F [E/F][SEF] ARC</b>	<b>IN, OUT</b>		<i>These settings are for phase-fault elements; earth-fault (and where appropriate SEF) protection, have duplicate sets e.g. 'Gn P/F ARC' becomes 'Gn E/F ARC' or 'Gn SEF ARC'.</i>
<b>Gn P/F [E/F][SEF] Line Check Trip</b>	<b>INST, DELAYED</b>		
<b>Gn P/F [E/F][SEF] Protection Trip 1</b>	<b>INST, DELAYED</b>		
<b>Gn P/F [E/F][SEF] Reclose DTL 1</b>	0.20, 0.21...2.0, 2.1... <b>3.0</b> ...20,21... 300, 360...3600, 3900...14400	sec	
<b>Gn P/F [E/F][SEF] Protection Trip 2</b>	<b>INST, DELAYED</b>		

Setting name	Range ( <b>bold</b> = default)	Units	Notes
Gn P/F [E/F][SEF] Reclose DTL 2	as Reclose DTL 1	sec	
Gn P/F [E/F][SEF] Protection Trip 3	INST, <b>DELAYED</b>		
Gn P/F [E/F][SEF] Reclose DTL 3	as Reclose DTL 1	sec	
Gn P/F [E/F][SEF] Protection Trip 4	INST, <b>DELAYED</b>		
Gn P/F [E/F][SEF] Reclose DTL 4	as Reclose DTL 1	sec	
Gn P/F [E/F][SEF] Shots To Lockout	1, 2, 3, <b>4</b>		<i>For 4 reclose shots, 5 trips are issued – the fifth trip is always delayed.</i>
Gn P/F [E/F] HS1 Trips to Lockout	1, 2, 3, 4, <b>5</b>		<i>Not applicable to SEF sequence</i>
Gn P/F [E/F] HS2 Trips to Lockout	1, 2, 3, 4, <b>5</b>		
<b>Reclaim Time</b>	0.20, 0.21... <b>2.0</b> , 2.1...20,21...300, 360...3600, 3900...14400	sec	<i>Common setting across all Groups applies to all Sequences</i>
<b>Close Pulse</b>	1.0, 1.1... <b>2.0</b> ...10.0	sec	<i>Common setting across all Groups</i>
<b>Manual Close Delay</b>	<b>OFF</b> , 1, 2, 3, 4, 5, 6, 7, 8, 9, 10	sec	<i>Common setting across all Groups</i>
<b>LO Recovery</b>	as 'Reclaim Time'	sec	<i>Common setting across all Groups</i>



Sub-menu: **O/P Relay Config.**

Setting name	Range ( <b>bold = default</b> )	Notes
<b>Gn Lockout Alarm</b>	_ or <b>1</b> for each output contact (default: _____ <b>1</b> )	<i>Default output = relay 7</i>
<b>Gn Close Pulse</b>	_ or <b>1</b> for each output contact (default: _____ <b>1</b> _____)	<i>Default output = relay 4</i>
<b>Gn AUX Close</b>	_ or <b>1</b> for each output contact (default: _____)	<i>Default output = None</i>
<b>Gn ARC Active</b>		
<b>Gn Reclaimed</b>		

Sub-menu: **Status Config.**

Setting name	Range ( <b>bold = default</b> )	Notes
<b>Gn CB Open</b>	_ or <b>1</b> for each status input (default: _____ <b>1</b> _____)	<i>Default input = 6</i>
<b>Gn CB Closed</b>	_ or <b>1</b> for each status input (default: _____ <b>1</b> _____)	<i>Default input = 7</i>
<b>Gn Reclose Block</b>	_ or <b>1</b> for each status input (default: _____)	<i>Default input = None</i>
<b>Gn P/F ARC Off</b>		
<b>Gn E/F ARC Off</b> <b>Gn SEF/REF ARC Off</b>		

## 2.9.1.2 External Protection Reclose Sequence

In addition to the relay's internal protection and auto-reclose sequences a programmable auto-reclose sequence and back-up protection functions for an external protection is provided.

The external protection trip is sensed on a status input, as set in the Status Config.:ARC Status A setting. This will typically be energised from the trip output, or starter output, of an external protection device e.g. a distance protection or sensitive earth-fault relay. The Argus 4/6 will then provide a separate auto-reclose sequence, with the external protection providing the fault detection and tripping functions. Up to four close shots (five trips) to lockout may be set with independent reclose delays.

The Auto-reclose:SA Trips to Block setting causes an output to be raised after a set number of trips in a sequence as set in the O/P Relay Config.:SA Blocked setting. This is intended to allow blocking of the external protection. For example, the Argus can provide the auto-reclose sequences and back-up IDMT protection to a distance protection. The distance relay could be allowed to trip twice, it can then be blocked and the IDMT protection of the Argus allowed to grade with other inverse protection relays to clear the fault.

Back-up protection is also provided by timers, as set by the O/P Relay Config.:Backup Alarm SA and O/P Relay Config.:Backup Trip SA settings, which run consecutively. When ARC Status A is raised, the Backup Alarm timer starts running, on time-out a SA Alarm is given and the Backup Trip timer then starts running, on its time-out the relay gives a SA Trip output. Both timers stop & reset when ARC Status A is cleared. This two stage back-up protection, therefore, has the external protection settings, e.g. Impedance or SEF levels. The timers provide a protection trip when the SA sequence has progressed to the point at which the external protection is blocked and the fault level falls below the overcurrent protection settings. For example; a five pole protection scheme can be engineered, with a 3P + E Argus 4 relay and a separate SEF relay, where the P/F, E/F, and SEF protection each have independent auto-reclose sequences.

Outputs from the alarm and trip are set using the O/P Relay Config.:SA Alarm and O/P Relay Config.:SA Trip settings.

All other settings relating to this function are as for the internal sequences described above, with the exception of line check trip. When the Auto-reclose:SA Line Check Trip setting is set to Delayed, the delay used is that given by the two stage back-up alarm and back-up trip times.

**Table 2-20 Auto-reclose from External Trip Settings**Sub-menu: **Protection**

Setting name	Range ( <b>bold = default</b> )	Units	Notes
<b>Gn Backup Alarm SA</b>	0.00, 0.01... <b>10.00</b> ...20.00	sec	
<b>Gn Backup Trip SA</b>	0.00, 0.01... <b>10.00</b> ...20.00	sec	

Sub-menu: **Auto-reclose**

Setting name	Range ( <b>bold</b> = default)	Units	Notes
<b>Gn SA ARC</b>	<b>IN, OUT</b>		If set to <i>OUT</i> and an SA input occurs then the relay will go to <i>LOCKOUT</i> .
<b>Gn SA Line Check Trip</b>	<b>INST, DELAYED</b>		
<b>Gn SA Reclose DTL 1</b> <b>Gn SA Reclose DTL 2</b> <b>Gn SA Reclose DTL 3</b> <b>Gn SA Reclose DTL 4</b>	0.20, 0.21...2.00, 2.1, 2.2... <b>3.0</b> ...20.0, 21, 22...300, 360, 420...3600, 3900, 4200...14400	sec	
<b>Gn SA Shots To Lockout</b>	<b>1, 2, 3, 4</b>		
<b>Gn SA Trips To Block</b>	<b>1, 2, 3, 4, 5</b>		

Sub-menu: **O/P Relay Config.**

Setting name	Range ( <b>bold</b> = default)	Notes	
<b>Gn SA Blocked</b>	<b>_</b> or <b>1</b> for each output contact (default: _____)	Default output = None	
<b>Gn SA Alarm</b>			
<b>Gn SA Trip</b>	<b>_</b> or <b>1</b> for each output contact (default: <b>_ 1</b> _____)	Default output = relay 2	

Sub-menu: **Status Config.**

Setting name	Range ( <b>bold</b> = default)	Notes	
<b>Gn ARC Status A</b>	<b>_</b> or <b>1</b> for each status input (default: _____)	Default input = None	

## 2.9.2 Control Inputs

The user enters the protection settings and auto-reclose sequence settings into the relay to set-up the required sequence for the different fault types, however, the operation of these functions may be modified or controlled by the programming inputs. These inputs may be via status inputs from external scheme logic and include blocking and CB Status inputs, or SCADA Control commands from the remote operator via the Communications link, or local commands via the Linesman Mode menu.

The Argus 2 and Argus 6 provide the following command set:

### Trip and Lockout

When this command is raised (edge triggered) any existing auto-reclose sequence is aborted, a defined trip pulse is issued and the relay then goes to lockout.

### Local Close and Reclaim

It is desirable that an Engineer should not be standing close to a Circuit Breaker when it is being closed, it could close onto a fault which could cause it to fail. This function inserts a Health and Safety time delay between the initiation by the operator of a Local Close & Reclaim command to the relay and the relay sending an output to the CLOSE circuit of the Circuit Breaker.

When a 'Local Close & Reclaim' command input (edge triggered) is raised the relay executes a 'CLOSE IN XX s' countdown timer before issuing the CLOSE pulse. The delay is set by the User in the Auto-reclose:Manual Close Delay setting, default OFF, to define the delay between the Command initiation being received by the relay and the CLOSE pulse being issued by the relay, thus allowing time for the operator to move away from the vicinity of the Circuit Breaker before it operates to close and make the circuit live.

When the CB is open and a CLOSE & RECLAIM command is raised, the relay jumps to the 'ARC Status' screen in which is displayed the count down timer 'CLOSE IN xx s' where the time 'xx s' is counted down from the User set Manual Close Delay value. On reaching the count of zero the CLOSE pulse is issued and the screen then shows the RECLAIM timer counting down after which 'RECLOSE SUCCESS' is displayed. Note:- the Manual Close delay starts when the mapped Status input is raised, clearing it and raising it again restarts the timer each time.

Application Note:- This function allows the normal panel mounted Circuit Breaker Control switch to initiate, via the relay, the delayed closing of the Circuit breaker thus removing complexity from the implementation of this Health and Safety feature.

If the CB is open the relay enables line check, then issues a defined close pulse and enters the reclaim delay. If

the CB closes onto a fault, or a fault occurs during the reclaim delay time, then the relay performs the programmed one trip to lockout.

The relay will not issue a close pulse to a circuit breaker that is indicating that it is closed, i.e. the double command status inputs CB Open is cleared and CB Closed is raised. If a Don't Believe It (DBI) condition exists, e.g. CB Open and CB Closed are both raised then the relay will issue the close pulse.

### Remote Close and Reclaim

When this command is raised (edge triggered) if the CB is open the relay enables line check, then immediately issues a defined close pulse and enters the reclaim delay. There is no delay, as for Local Close & Reclaim, since there are tight 'Time allowed to live' limits on SCADA commands.

If the CB closes onto a fault, or a fault occurs during the reclaim delay time, then the relay performs the programmed one trip to lockout.

The relay will not issue a close pulse to a circuit breaker that is indicating that it is closed, i.e. the double command status inputs CB Open is cleared and CB Closed is raised. If a Don't Believe It (DBI) condition exists, e.g. CB Open and CB Closed are both raised the relay will issue the close pulse.

### Trip and Auto-reclose

When this command is raised (edge triggered) the relay immediately issues a trip pulse then, after the first phase-fault reclose delay, it enables line check then issues a close pulse to reclose the circuit breaker and enters reclaim. If the CB closes onto a fault, or a fault develops during reclaim, then the relay will perform the line check one trip to lockout. This command is typically used for a routine test of the Trip and Close operations of the Circuit Breaker.

### Close and Lock-in

When this command is raised (edge triggered) if the CB is open the relay immediately issues a defined close pulse and then inhibits all Protection and Autoreclose functions. This allows the circuit breaker to be operated as a switch without protection trip functions.

**Table 2-21 Auto-reclose Commands Settings**

Sub-menu: **Auto-reclose**

Setting name	Range ( <b>bold = default</b> )	Units	Notes
<b>Manual Close Delay</b>	<b>OFF</b> , 1, 2...10	sec	

Sub-menu: **Status Config.**

Setting name	Range ( <b>bold = default</b> )	Units	Notes
<b>Gn Trip &amp; ARC</b>	_, 1 for each status input (default: _____)		
<b>Gn Close &amp; Lockin</b>	_, 1 for each status input (default: _____ <b>1</b> _)		
<b>Gn Local Close &amp; Reclaim</b>	_, 1 for each status input (default: _____ <b>1</b> )		
<b>Gn Remote Close Reclaim</b>	_, 1 for each status input (default: _____)		

## 2.9.3 Frequent Operations Counter

Argus 4 & 6 relays incorporate a Frequent Operations Counter (FOC) which operates to prevent cyclical operations caused by multiple fault re-occurrences or by setting interactions between AutoReclosers at different points in the system in response to a permanent fault. While the FOC is exceeded it will act to truncate and modify a sequence to break the cyclical operation. The FOC also acts to limit the number of Circuit Breaker operations per hour to the value set by the User.

For further details see section 2.14.1.4.

## 2.9.4 Hot (Live) Line Working

When maintenance is being performed on an overhead line, or new equipment is being added, it can be inconvenient or impractical to make the line dead. Live line working can be performed using special tools and equipment. When live line working is being performed all auto-reclose sequences should be inhibited and any fault must force an instantaneous Trip to Lockout.

The hot line working mode is enabled from a status input (as defined by the [Status Config.:Hot Line Working](#) setting), from the relay's [Linesman Mode](#) (section 2.15), or via the IEC communications link. For hot line working to be disabled none of these inputs can be on.

In the hot line working mode, if fault current above any starter setting is seen, the relay will give a single instantaneous trip and lockout overriding all protection/auto-reclose settings and inhibits.

**Table 2-22 Live Line Working Setting**

Sub-menu: **Status Config.**

Setting name	Range ( <b>bold = default</b> )	Units	Notes
<b>Gn Hot Line Working</b>	<b>_, 1</b> for each status input (default: _____)		

## 2.10 Trip Circuit Supervision

One, or more, trip circuits can be monitored by connecting a status input in each trip circuit to be supervised, e.g. as shown in the application diagram

Figure 3.8-1 & 3-9 The inputs are specified with the [Status Config.:Trip Circuit Fail](#) setting.

If all mapped status inputs are energised (raised) then the trip circuits are considered healthy. If any trip circuit loses auxiliary supply, or becomes high resistance or open-circuit, then the wired status input will be de-energised (cleared) and a trip circuit fail alarm and indication raised.

Local indication will be in the form of a message on the LCD, e.g. 'Trip Circuit FAIL S1+3' if the trip circuits associated with status inputs 1 and 3 have failed.

By mapping each trip circuit fail status input to a changeover contact an alarm output can also be generated from the normally-closed contact. A suitable pick-up delay should be set on the status input. More details about the application of trip circuit supervision are given in the Application Notes - Section 3.8.

**Table 2-23 Trip Circuit Supervision Settings**

Sub-menu: **Status Config.**

Setting name	Range ( <b>bold = default</b> )	Units	Notes
<b>Gn Trip Circuit Fail</b>	<b>_, 1</b> for each status input (default: _____)		

## 2.11 Status inputs and Relay Outputs

The status inputs and relay outputs are all user-programmable. The settings related to each function are described in the relevant section of this document. The relevant Diagrams and Parameters document for each Argus series provides matrix diagrams that allow user mappings of the status inputs and output relays to be recorded.

It is possible to map status inputs to directly operate relay outputs, using the [O/P Relay Config.:Status n](#) settings.

The operation of the status inputs and output relays is described below and shown in Figure 2.11-1 and Figure 2.11-2 respectively.

### Hand Reset Output Relays

Relay outputs are self-resetting by default; however, each relay output can be individually set to hand reset. In this case, the relay latches on operation and can be released by using the TEST/RESET key on the relay fascia (from the [Identifier](#) screen), by the communications link, or by energising a status input - as mapped by [O/P Relay Config.:Reset Flags & Outputs](#).

### Pulsed Output Relays

*Argus 4 and Argus 6 only.*

Output relays can be set as pulsed by the [O/P Relay Config.:Pulsed Relays](#) setting. Rather than remaining energised for the period that any mapped output signal is activated, a pulsed output relay will be energised for the minimum energise time, see Table 2-24, and will then be de-energised. It will remain de-energised until the output signal is deactivated and reactivated, whereupon another pulsed output will occur.

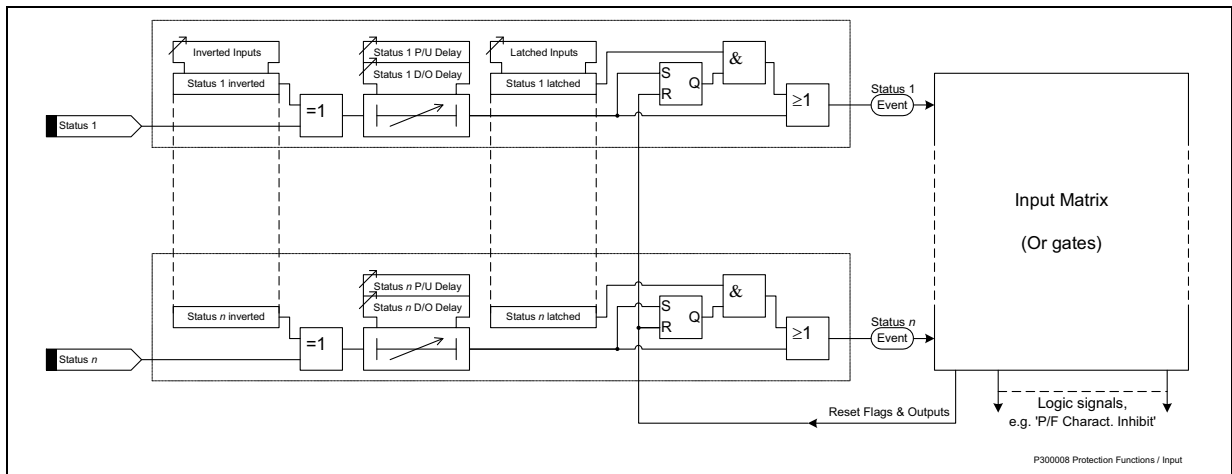
**Output Relay Minimum Energise Time**

All relay outputs can have their minimum energise time set by the O/P Relay Config.:Min O/P Energise Time.

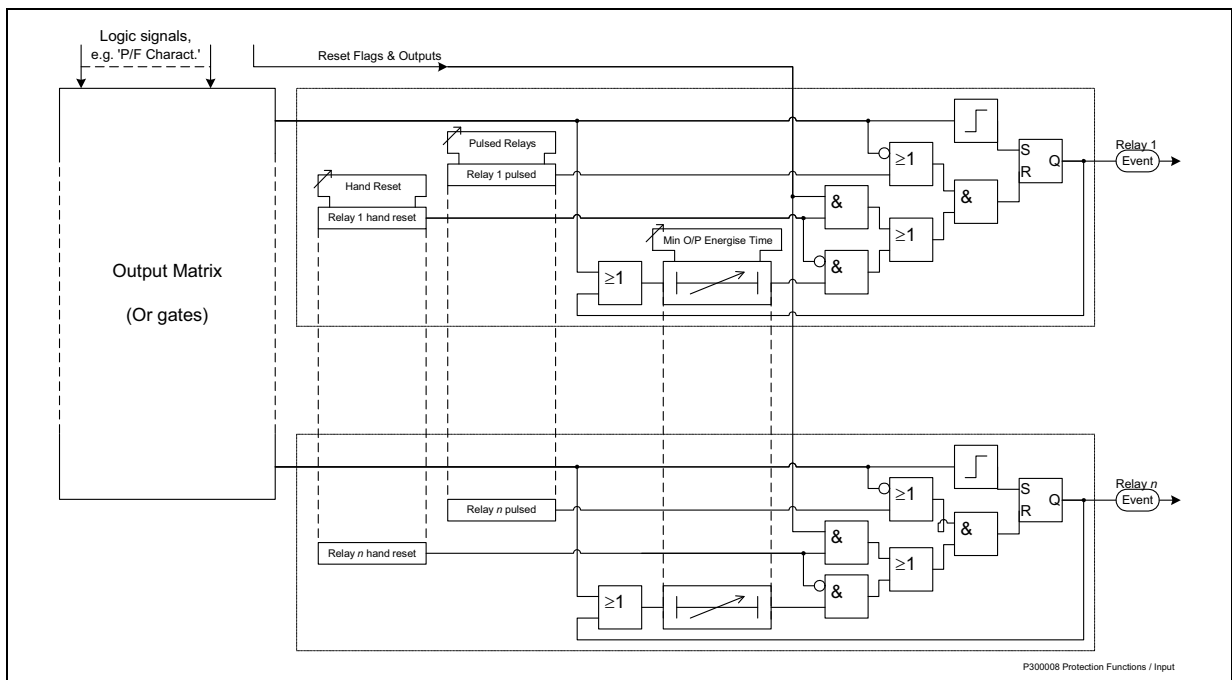
**Status Input Inversion and Delays**

Each status input can be set to inverted action i.e. the internal signal is raised when the input is de-energised and cleared when energised, using the Status Config.:Inverted Inputs setting.

Each status input can also be programmed with a pick-up and drop-off delay, using the Status Config.:Status n P/U Delay and Status Config.:Status n D/O Delay settings. The pick-up and drop-off delays are applied following the inversion, i.e. pick-up delay applies to the input becoming active, while drop-off applies to it becoming inactive.



**Figure 2.11-1 Status Input Logic**



**Figure 2.11-2 Output Relay Logic**

**Table 2-24 General Output Relay and Status Input Settings**

Sub-menu: **O/P Relay Config.**

Setting name	Range ( <b>bold = default</b> )	Units	Notes
<b>Gn Status 1</b>	_, 1 for each output contact (default: _ _ _ _ _)		<i>n is the number of status inputs present</i>
<b>Gn Status 2</b>			
...			
<b>Gn Status n</b>			

Setting name	Range ( <b>bold = default</b> )	Units	Notes
<b>Gn Hand Reset</b>			
<b>Gn Pulsed Relays</b>			<i>Argus 4 and Argus 6 only.</i>
<b>Min O/P Energerise Time</b>	<b>100</b> , 150...500	ms	

Sub-menu: **Status Config.**

Setting name	Range ( <b>bold = default</b> )	Units	Notes
<b>Inverted Inputs</b>	_, 1 for each status input (default: _ _ _ _ _)		
<b>Latched inputs</b>			<i>Argus 4 and Argus 6 only.</i>
<b>Gn Status 1 P/U Delay</b> <b>Gn Status 1 D/O Delay</b> <b>Gn Status 2 P/U Delay</b> <b>Gn Status 2 D/O Delay</b> ... <b>Gn Status n P/U Delay</b> <b>Gn Status n D/O Delay</b>	0.00, 0.01, 0.02...2.0, 2.1...20, 21... 300, 360...3600, 3900...14400d	sec	<i>Default settings of 0.02 for pick-up and 0.01 for drop-off are applied to give AC rejection. n is the number of status inputs present.</i>
<b>Gn Reset Flag &amp; Outputs</b>	_, 1 for each status input (default: _ _ _ _ _)		

## 2.12 Communications

All settings and information relating to communications with the Argus, are given in Section 4: Communication Interface.

## 2.13 Data Storage

Argus relays store three types of data to assist the user in fault evaluation i.e. events, waveforms and faults.

### 2.13.1 Event Storage

When an event occurs a date and time tagged entry is added to the storage buffer. Some of the events that can be stored are indicated in the function diagrams throughout this functional description section. Up to 500 events are stored in a rolling buffer, with the oldest events overwritten. The buffer can be cleared using the Data Storage:Clear All Events setting.

All events can be obtained through the communications link and are displayed in the Reydisp Evolution package in chronological order, allowing the user to see the sequence of events surrounding a trip. They are also made available spontaneously to a compliant control system.

For a complete listing of events available in each model refer to the appropriate Diagrams and Parameters document.

### 2.13.2 Fault Data Record

A Fault Data Record is a time-tagged textual record of the conditions at the instant of a Fault Trigger e.g. Trip, Table 2-25 shows all possible entries in a fault record. Details are included of all operated or operating protection elements, magnitudes and directions of currents in each pole at the time of trip.

A Fault Data record is triggered when any output relay, as designated in the Data Storage:Gn Fault Trigger setting, operates in combination with any protection element, or a status input mapped to a Fault Trigger output relay is raised. To trigger a Fault Data record from an external protection device connect its trip output to a status input which is mapped to a Data Storage:Gn Fault Trigger output relay.

**Note.** Unless an output relay is set=1 in the Data Storage:Fault Trigger setting then no fault data record will be stored when a protection function assigned to that output relay operates.

Up to 5 faults are stored in a rolling buffer, with oldest faults overwritten. All Fault Data records can be cleared if Data Storage:Clear All Faults is set to YES.

**Table 2-25 List of Entries for Fault Data Records**

Type	Fault Record Entry	Description
Date & Time	dd/mm/yy hh:mm:ss.ss	Time stamp

Type	Fault Record Entry	Description
Group	Gn	Active setting group at time of trip, where <i>n</i> is the group number
Poles	PHASE A, PHASE B, PHASE C, EARTH FAULT, SEF, REF	
	Direction	FWD (or user tag) REV (or user tag)
Elements	LS	Lowset
	DTL	Time-delayed characteristic (set to DTL)
	IDMTL	Time-delayed characteristic (set to IDMTL)
	HS1	Highset 1
	HS2	Highset 2
	TIMER 1	SEF/REF 1 <sup>st</sup> time delay
	TIMER 2	SEF/REF 2 <sup>nd</sup> time delay
	EXTERNAL TRIP	Trip generated externally and monitored through status input
	CB FAIL 1	Circuit breaker fail re-trip
	CB FAIL 1 + 2	Circuit breaker fail back-trip
	<XX>	Element shown e.g. '< IDMTL >' raised the fault trigger
	Current	IA=xxx
IB=xxx		Current of phase B is xxx
IC=xxx		Current of phase C is xxx
IE=xxx		Current of earth-fault pole is xxx
ISE=xxx		Current of sensitive or restricted earth-fault pole is xxx
Voltage	VA=xxx	Voltage of phase A is xxx
	VB=xxx	Voltage of phase B is xxx
	VC=xxx	Voltage of phase C is xxx
	VN=xxx	Neutral displacement voltage is xxx
Auto-reclose	TRIP & RECLOSE	Autoreclose following trip
	HOT LINE LOCKOUT	Recloser locked out following trip, due to hot line working active
	TRIP & LOCKOUT	Recloser locked out following trip
	LINE CHECK TRIP	Trip due to switch onto fault
	SA TRIP	External trip
General Alarms	(user defined text tag)	A user-defined text tag can be programmed, e.g. 'BUCHHOLZ TRIP'. Multiple Alarms are concatenated with '+' symbols

### Example

'12/05/04 17:25:51.2525 G1 PHASE A LS IDMTL <HS1> HS2 IA = 12.32xIn, PHASE B LS IDMTL HS1 HS2 IB = 12.23xIn, PHASE C LS IC=0.78xIn, EARTH FAULT LS IDMTL IE=0.27xIn', BUCHHOLZ TRIP

This specifies the date and time of the trip and that settings group 1 was active at the time of trip. On phase A the lowset, delayed characteristic, and highsets 1 and 2 were picked up. Phase A highset 1 issued the trip/fault trigger. Phase A current was 12.32 xIn. On phase B the lowset, delayed characteristic, highset 1 and highset 2 were picked up with a current of 12.23 xIn. On phase C the lowset element was picked up with a current of 0.78 xIn. The earth-fault lowset and delayed characteristic elements were picked up with a current of 0.27 xIn, and a General alarm 'BUCHHOLZ TRIP' was raised. Basically a Phase A to B fault with some Earth fault component, Phase C unfaulted.

### 2.13.3 Waveform (Disturbance) Records

Waveform Record storage is a digital graphical record of analogue current (and for Argus 2 type II voltage) inputs, status inputs and relay outputs.

Each record is one second in length and is triggered from a protection element operating or from a status input as designated in the [Data Storage:Waveform Trig](#) setting. This allows the user to specify one or more trigger methods:

phase fault (P/F), earth-fault (E/F), SEF, Status input (STA) and/or Voltage element operation. When status input trigger is selected, the inputs used are specified by the Status Config:Waveform Trig setting.

**Note.** Unless the correct settings are applied as described above then no waveform record may be stored in the event of a fault.

When storage is triggered some pre-trigger waveform may be stored, the percentage of which is specified by the Data Storage:Waveform Pre-Trigger setting. Suggested setting is 80% pre-trigger.

Up to 5 waveforms are stored in a rolling buffer, oldest waveforms are overwritten by new. The waveform storage can be cleared if Data Storage:Clear All Waveforms is set to YES.

### 2.13.4 Maximum Demand Function

This feature enables the relay to perform an average and maximum demand function of the following measured quantities:

IA

IB

IC

Watts – AG2-5\* only

VARs – AG2-5\* only

There are two user configurations for this feature: -

The first is a rolling window which measures the average quantities over a rolling window of 'n' minutes. i.e. as new values are added old values are removed from the sum – the average is calculated constantly.

The second method is a fixed window where the sum is reset at the start of the window and incremented with new values until the end of the window period. Upon reaching the end of the window the average is calculated and a new window started.

The average and maximum quantities are reported with new instruments, one for each quantity, i.e. one screen would show:

IA MAX = 300.0 ROLL = 176.0	or	IA MAX = 300.0 FIXED = 176.0
--------------------------------	----	---------------------------------

The display depends upon the window type. The size of the window can be set by the user with the Data Storage:Demand Window = xxxx minutes setting. The maximum quantities do not have any relationship to the window and will report the maximum quantities since the last user reset of this function. Resetting the quantities can be done either from the setting 'Maximum Demand Reset', the instruments screen, or via an IEC60870 comms command.

**Table 2-26 Data Storage Settings**

Sub-menu: **Status Config.**

Setting name	Range ( <b>bold = default</b> )	Units	Notes
<b>Gn Waveform Trig</b>	_, 1 for each status input (default: <b>_____</b> )		<i>The trigger must also be set to <u>STAtus</u> in the Data Storage menu.</i>

Sub-menu: **Data Storage**

Setting name	Range ( <b>bold = default</b> )	Units	Notes
<b>Gn Fault Trigger</b>	_, 1 for each output contact (default: <b>_ 1 _____</b> )		
<b>Gn Waveform Trig</b>	_, 1 for each of P/F, E/F, SEF, <u>STAtus</u> , V (default: <b>_____ all Off</b> )		<i>'V' applies only to Argus 2 type II.</i>
<b>Gn Waveform Pre-Trigger</b>	OFF, <b>10</b> , 20...100	%	<i>Suggested setting 80%</i>
<b>Clear All Waveforms</b>	<b>NO</b> , YES Self-resetting		<i>Yes/No confirmation required</i>
<b>Clear All Events</b>			
<b>Clear All Faults</b>			
<b>Demand Window Type</b>	<b>OFF</b> , ROLLING, FIXED		



Setting name	Range ( <b>bold = default</b> )	Units	Notes
<b>Demand Window</b>	5, 10, <b>15</b> .. 60, 90 .. 300, 360 .. 1440	mins	
<b>Maximum Demand Reset</b>	<b>NO</b> , YES Self-resetting		Yes/No confirmation required

Sub-menu: **CB Maintenance.**

Setting name	Range ( <b>bold = default</b> )	Units	Notes
<b>Energy Meter Reset</b>	<b>NO</b> , YES Self-resetting		V' applies only to Argus 2 type II. Yes/No confirmation required

## 2.14 Maintenance

This section covers features to assist in the maintenance of circuit breakers, the protection scheme and the Argus relay itself.

### 2.14.1 Circuit Breaker Operations

Trip counts and  $I^2$  summation occur for each internal or external trip, as specified by Data Storage:Fault Trigger, see section 2.13.2.

#### 2.14.1.1 Trip Counter

A trip counter is provided which increments on each trip command issued.

A suitable maintenance limit value can be chosen from the circuit breaker manufacturer's data and entered into the CB Maintenance:Trip Counter Alarm setting. When the alarm setting is exceeded, the output relays mapped by O/P Relay Config.:Trip Counter Alarm are raised.

The count can be reset using CB Maintenance:Trip Counter Reset, or when viewing the counter's instrument.

#### 2.14.1.2 Sum of $I^2$

Circuit breaker contact wear increases with energy broken, therefore  $I^2$  summation provides a good estimation for maintenance purposes. A suitable maintenance limit value can be chosen from the circuit breaker manufacturer's data and entered into the CB Maintenance: $I^2$  Alarm setting.

The current flowing at the time of trip is added to individual summations for each phase. If any of these exceed the alarm setting, the output relays mapped by O/P Relay Config.: $I^2$  Alarm are raised. An instrument shows the largest  $I^2$  summation of the three phases.

The summation can be reset using CB Maintenance: $I^2$  Reset, or when viewing the summation instrument.

#### 2.14.1.3 Delta Trip Counter

*Argus 4 and Argus 6 only*

This provides an additional counter, which can be reset independently of the Trip Counter described above. This can then be used, for example, for recording trip operations between visits to a substation.

Its operation is similar to the Trip Counter above, however a different limit setting (CB Maintenance: $\Delta$  Trip Counter Alarm) and output (O/P Relay Config.: $\Delta$  Trip Alarm) are provided.

The delta trip counter can be reset using CB Maintenance: $\Delta$  Trip Counter Reset and when viewing the counter's instrument, also by a status input mapped by Status Config.: $\Delta$  Trip Counter Reset.

#### 2.14.1.4 Frequent Operations Counter

*Argus 4 and Argus 6 only*

Argus 4 and 6 relays incorporate a Frequent Operations Counter (FOC) which logs the number of trip operations in each minute-window in a rolling window of one hour. When the total number of trip operations in one hour reaches or exceeds that set by the user in the CB Maintenance:Freq Op Counter Alarm setting then all protection and auto-reclose settings are replaced by a Delay (+HS1+HS2 if applicable) characteristic and one trip to lockout operation. The normally active protection and sequence settings are suspended until the total number of operations decrements to below the counter setting as the rolling one hour window drops off the high trip count minute-windows.

The standing number of FOC trips and the FOC Alarm level are displayed in the Instruments:Freq Op Counter. The FOC counter can be reset using CB Maintenance:Freq Op Counter Reset, when viewing the counter's instrument, or by raising a status input mapped to Status Config:FOC Reset.

**Table 2-27 Circuit Breaker Maintenance Settings**

Sub-menu: **CB Maintenance**

Setting name	Range ( <b>bold = default</b> )	Units	Notes
<b>Δ Trip Counter Reset</b>	<b>NO</b> , YES		<i>Argus 4 and Argus 6 only.</i>
<b>Δ Trip Counter Alarm</b>	<b>OFF</b> , 1, 2...999		
<b>Trip Counter Reset</b>	<b>NO</b> , YES		
<b>Trip Counter Alarm.</b>	<b>OFF</b> , 1, 2...999		
<b>Freq Op Counter Reset.</b>	<b>NO</b> , YES		<i>Argus 4 and Argus 6 only.</i>
<b>Freq Op Counter Alarm</b>	<b>OFF</b> , 1, 2...999		
<b>ΣI<sup>2</sup> Reset</b>	<b>NO</b> , YES		
<b>ΣI<sup>2</sup> Alarm</b>	<b>OFF</b> , 10, 11...100, 110... 20000, 21000...100000	MA <sup>2</sup>	

Sub-menu: **O/P Relay Config.**

Setting name	Range ( <b>bold = default</b> )	Units	Notes
<b>Gn ΔTrip Alarm</b>			<i>Argus 4 and Argus 6 only.</i>
<b>Gn Counter Alarm</b>	_, 1 for each output contact (default: _____)		
<b>Gn ΣI<sup>2</sup> Alarm</b>			
<b>Gn FOC Alarm</b>			<i>Argus 4 and Argus 6 only.</i>

Sub-menu: **Status Config.**

Setting name	Range ( <b>bold = default</b> )	Units	Notes
<b>Gn ΔTrip Counter Reset</b>			<i>Argus 4 and Argus 6 only.</i>
<b>Gn Counter Reset</b>	_, 1 for each status input (default: _____)		
<b>Gn FOC Reset</b>			<i>Argus 4 and Argus 6 only.</i>
<b>Gn ΣI<sup>2</sup> Update</b>			

## 2.14.2 Output Relay Test

The output relay test allows the Argus to simulate a particular element operation, e.g. P/F Highset 1, and energise all output contacts that would normally be energised from that element output. This is useful during commissioning/routine tests, so that wiring and operational checks can be performed without the need for secondary injection.

The required element is selected from the list available in the CB Maintenance:O/P Relay Test setting. Scroll to that setting, press ENTER, select the required element name using the up or down keys, press ENTER to select, a confirmation screen ' \*\* O/P Test \*\* Are You Sure ? N ' will be shown, confirm by using the up or down key to change to ' Y ' and press ENTER. An active countdown timer will then be shown in a ' \*\* TRIP TEST IN\*\* , \*\* xx SECONDS \*\* ' screen. The counter decrements from 10 seconds to zero, then all output relays mapped to that element are energised for 100ms, then a message TRIP TEST FINISHED is briefly displayed.

The time delay before output relay energisation allows personnel to leave the vicinity of the circuit breaker before a live system trip test is performed.

**Table 2-28 Output Relay Test Setting**

Sub-menu: **CB Maintenance**

Setting name	Range ( <b>bold = default</b> )	Units	Notes
--------------	---------------------------------	-------	-------

<u>Setting name</u>	<u>Range (bold = default)</u>	<u>Units</u>	<u>Notes</u>
<b>O/P Relay Test</b>	<b>OFF</b> , Protection Healthy, all P/F, E/F, SEF overcurrent element outputs all voltage elements, all mapped status, Alarms, counters, hand & pulsed relays, Lockout alarm, Close pulse, Aux Close, ARC active, Reclaimed, SA Blocked, SA Alarm, SA Trip,		<b>YES / NO confirmation is required.</b>

### 2.14.3 Internal Supervision

The Argus relay applies comprehensive supervision of its internal operation, both hardware and software. In the event of any failure all outputs are de-energised and the relay is shut down in a controlled manner. Supervision includes a power supply watchdog, code execution watchdog, memory checks by checksum, memory addressing checks and processor and ADC health checks.

While the relay is healthy an output can be given as specified by the Output Relay:Prot. Healthy, setting. By allocating this output to a normally closed contact, i.e. any output relays 1 to 3, an alarm can be generated by relay de-energisation or Protection Healthy failure. Note: relay withdrawal will also generate an alarm as all normally closed contacts have 'CT' shorting contacts which close when the relay is withdrawn from its case.

If an internal failure is detected a relevant identifying message will be displayed if possible and the Argus will reset and restart in an attempt to restore normal operation, this will result in de-energisation of the protection healthy contact and flashing of the protection healthy LED. Reset takes about 2 - 3 seconds.

Each time power is applied to the relay or the relay resets, internal Power On and Reset counters are incremented; the total count is shown in Instruments:Power On Count. An alarm level can be set in the CB Maintenance:Power On Count Alarm and an output will be raised if the count is exceeded, this can be mapped to an output relay Output Relay:Power On Count. This can be useful in tracing problems with substation batteries or relays. The count can be reset either from the Instrument display by pressing TEST/RESET, use up /down keys to confirm ' Y ', press TEST/RESET again; or, from the CB Maintenance menu using the ENTER and up /down keys to select ' Y ' and confirm.

**Table 2-29 Internal Supervision Setting**

Sub-menu: **O/P Relay Config.**

<u>Setting name</u>	<u>Range (bold = default)</u>	<u>Units</u>	<u>Notes</u>
<b>Gn Prot. Healthy</b>	_, 1 for each output contact (default: 1 _____)		
<b>Gn PowerOn Count</b>	_, 1 for each output contact (default: 1 _____)		

Sub-menu: **CB Maintenance**

<u>Setting name</u>	<u>Range (bold = default)</u>	<u>Units</u>	<u>Notes</u>
<b>Power On Count Reset</b>	<b>NO</b> , YES		<b>YES / NO confirmation is required.</b>
<b>Power On Count Alarm</b>	<b>OFF</b> , 1, 2...999		

## 2.15 Linesman Mode

*Argus 4 and Argus 6 only*

Linesman mode is a special mode available on Argus 4 and Argus 6 relays which provides a limited command set that is intended to allow a user (Linesman) simple access to enable and disable various features when working on the line, particularly for live line working.

Access to a selected set of settings from various parts within the menu system is provided in the Linesman Mode menu, together with some commands. These settings differ slightly from other settings in that they are not password protected and can be accessed and changed using the right (►) key, this allows them to be set with the relay front cover in place.

The linesman mode is easily reached from the top of the menu tree using the down (▼) key.

If the linesman mode is not required it can be hidden using System Config:Linesman Display, which is password protected. This setting allows a controlling setting such as SEF\_OFF to be set and then hidden such that it cannot accidentally, or easily, be turned back on again

**Table 2-30 Linesman Mode Setting**

Sub-menu: **System Config.**

Setting name	Range ( <b>bold</b> = default)	Units	Notes
<b>Linesman Display</b>	<b>VISIBLE</b> , HIDDEN		<i>If attempts are made to access Linesman mode when it is set to <b>Hidden</b> the Display will show 'Linesman Display ' hidden'</i>

**Table 2-31 Linesman Mode Settings and Commands**

Setting name	Range ( <b>bold</b> = default)	Units	Note:- <u>YES</u> / <u>NO</u> confirmation required.
<b>Scada Control</b>	OFF, <b>ON</b>		
<b>Hot Line Working</b>	<b>OFF</b> , ON		<i>Set to <b>ON</b> for live line working. When set 'On', detection of a fault causes an instantaneous trip and lockout.</i>
<b>Trip &amp; Lockout</b>	<b>NO</b> , YES		<i>Normally set to <u>NO</u>, set to '<u>YES</u>' and confirm <u>Y</u> to carry out command.</i>
<b>Trip &amp; Reclose</b>			
<b>Close &amp; Reclaim</b>			
<b>ARC</b>	OFF, <b>ON</b>		
<b>Inst. Lowset</b>	<b>OFF</b> , ON		
<b>Trip Counter Reset</b>	<b>NO</b> , YES		
<b>SEF</b>	OFF, <b>ON</b>		

## Section 3: Application Notes

### 3.1 Selection of Characteristics

In most applications, especially where the relay must grade with other IDMTL relays on the system, the characteristic curve is selected to be the same type as the others - e.g. most relays have normal inverse curves type A to IEC 60255-3 and this would be the usual choice on the Argus relay. Extremely inverse curves type C to IEC 60255-3 are often used to grade with fuses or moulded case circuit breakers. Operating times become slower higher up the system due to the required grading margins between characteristics and VI and NI characteristics are needed. Long Time Inverse can be used for thermal protection.

The Argus relay measures true RMS values of current and for this reason can be used to protect capacitor banks or other circuits where harmonics are significant.

Each pole has four independent overcurrent stages and each stage may be instantaneous or time lagged. When grading with fuses, these characteristics may be combined to give a composite curve to correctly co-ordinate.

The use of an instantaneous element is common on transformer protection to give fast clearance of terminal faults. In some instances, such as a feeder that is cabled from a substation and then becomes an overhead line, the highset can be selected to operate only for cable faults and can be utilised to block auto-reclosing.

Argus relays can be supplied with sensitive earth-fault or restricted earth-fault functions. Refer to the VA TECH Reyrolle ACP Application Guide on REF for details.

#### 3.1.1 Reset Delay

The increasing use of plastic insulated cables, both conventionally buried and aerial bundled conductor, have given rise to the number of flashing intermittent faults on distribution systems. At the fault position the plastic melts and temporarily reseals the faulty cable for a short time after which the insulation fails again. The same phenomenon has occurred in compound-filled joint boxes where an internal flashover temporarily reseals.

The repeating process of the fault often causes electromechanical disc relays to “ratchet” up and eventually trip the faulty circuit if the reset time of the relay was longer than the time between successive flashes. Early electronic IDMTL relays with instantaneous reset features were not at all effective in dealing with this condition and only tripped after the flashing fault had developed into a solid permanent fault.

To overcome this the Argus relay has a reset that can be user programmed to be either instantaneous or delayed from 1 to 60 seconds in 1-second steps. Where Argus relays are used to protect cable feeders, it is recommended that a 60 second reset delay be used.

On overhead line networks, particularly where reclosers are incorporated in the protected system, instantaneous resetting is desirable to ensure that, on multiple shot reclosing schemes, correct grading between the source relays and the relays associated with the reclosers is maintained.

### 3.2 Directional Protection

Argus 2 and Argus 6 relays incorporate discrete directional elements with comprehensive selection so that each of the 4 current measuring devices can be selected to be either non-directional, forward directional, reverse directional or bi-directional. In the bi-directional mode, separate sets of settings can be assigned to the forward and reverse elements. For example, the IDMTL function could be set to be 100% 0.4 time multiplier in the forward direction and 15% 0.1 time multiplier in the reverse direction. Similarly, each of the Low Set and High Set elements can have different current and time settings in each direction and each of the elements can be mapped to any output relay(s).

Convention dictates that forward direction refers to power flow away from the busbar, while reverse direction refers to power flowing towards the busbar.

#### 3.2.1 Parallel or Ring Feeder Protection

Consider the network shown in Figure 3.2-1.

Circuit breakers at E and G would have Argus 2/6 relays installed, set to bi-directional. The E & G reverse IDMTL elements must be set to grade with the forward settings on the load circuit breaker relays and the C & D forward element settings; the E & G forward IDMTL elements are set more sensitive, i.e. with lower current and time multiplier settings to detect feeder faults.

For a fault as shown, close to the load substation, the currents at breakers C and D will have similar levels and their associated Argus relays will have prospective operate times of the same order. For the anti-clockwise fault current flow through C, G FWD must be set to be faster than E REV which in turn must be faster than C (FWD). Relay G will thus Trip first on FWD settings to stop the back feed of the fault, leaving D (FWD) to operate to clear the fault and the un-faulted Feeder C maintains power to the load.

If the fault occurred on feeder C, then clockwise fault current will flow through D, E FWD must be set to be faster than G REV which in turn must be faster than D. Relay E will thus Trip first on FWD settings to stop the back feed of the fault, leaving C (FWD) to operate to clear the fault and the un-faulted Feeder D (FWD) maintains power to the load.

Relays at C and D at the main substation could be set to non-directional but by setting them to be directional, the bi-directional function enables different settings to be applied for feeder and busbar faults. At A and B, bi-directional relays enable sensitive settings to be applied to the forward direction to detect transformer faults whilst reverse settings can be graded with forward settings at C and D.

By using a single bi-directional Argus relay, with different settings for forward and reverse directions, complex ring circuits can be set to grade correctly whether fault current flows in a clockwise or counter clockwise direction, i.e. only one relay must be used where normally two relays are required. The same applies to Generator circuits.

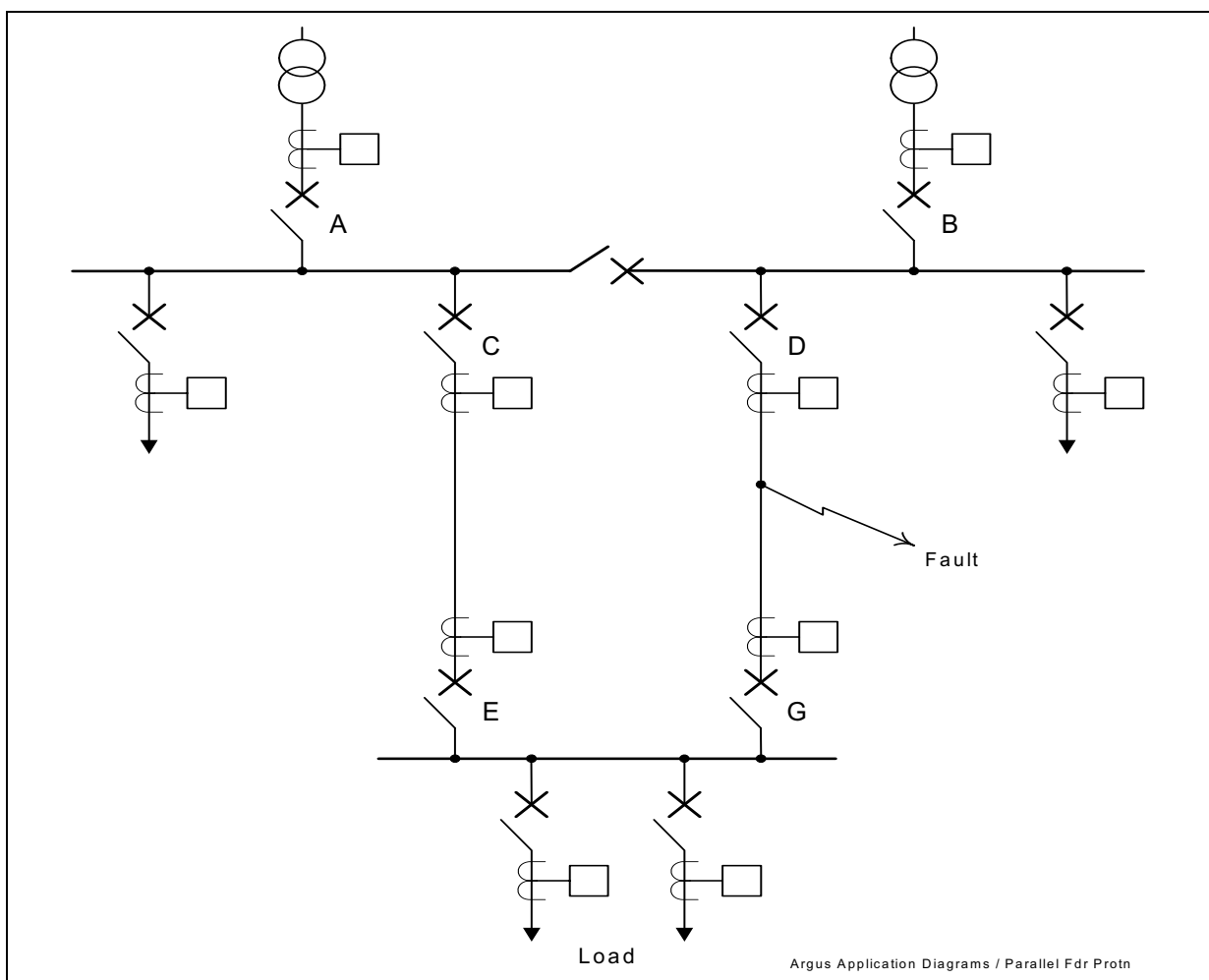


Figure 3.2-1 Parallel Feeder Protection

### 3.3 Sensitive Earth-fault Protection

Where sensitive earth-fault settings are required, the setting must be above any line charging current levels that can be detected by the relay.

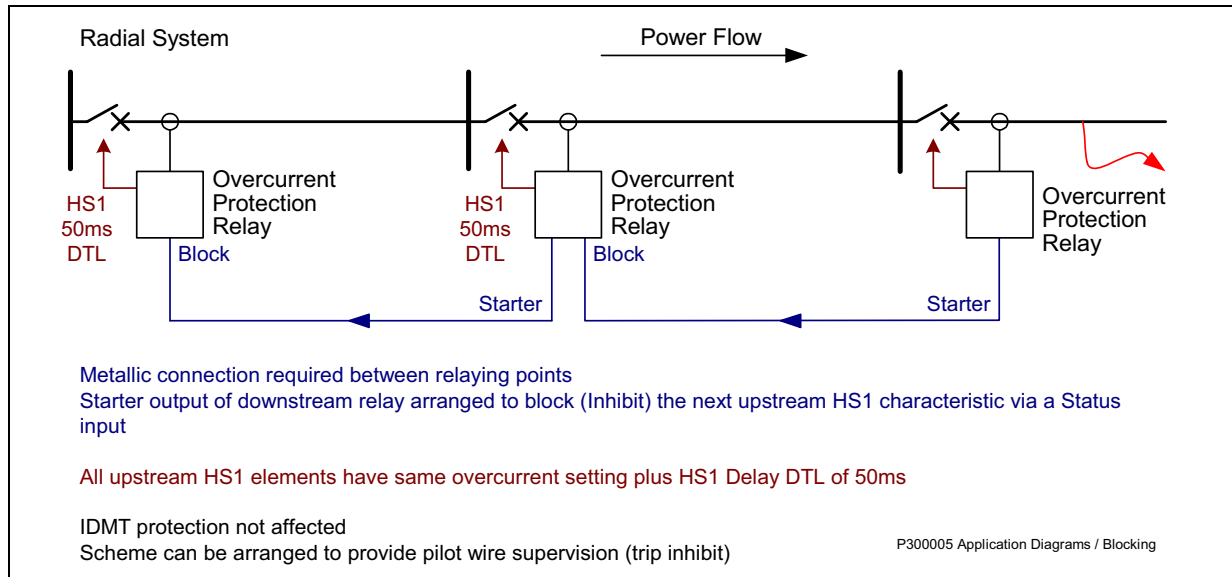
On occurrence of an out of zone earth fault the elevation of sound phase voltage to earth in a non-effectively earthed system can result in a zero sequence current of up to 3 times phase charging current flowing through the relay location.

The step change from balanced 3-phase charging currents to this level of zero sequence current includes transients. It is recommended to allow for a transient factor of 2 to 3 when determining the limit of charging

current. Based on the above considerations the minimum setting of a relay in a resistance earthed power system is 6 to 9 times the charging current per phase.

### 3.4 Blocking Schemes

Where substations in a radial network are physically close, such as on the MV system in a power station, and pilot cables can be economically run between switchboards, the times set on a particular relay and an upstream relay can be made identical. This reduces the fault clearance time by eliminating the grading margin delay. To achieve this, the Overcurrent starter contact of the downstream relay is connected via pilot wires to Block (inhibit) the upstream relay. Grading is ensured by this blocking feature provided that the upstream tripping time is set to be longer, with margin, than the time taken for the downstream blocking signal input to be raised. Figure 3.4-1 illustrates the scheme.



**Figure 3.4-1 Blocking scheme giving fast fault clearance**

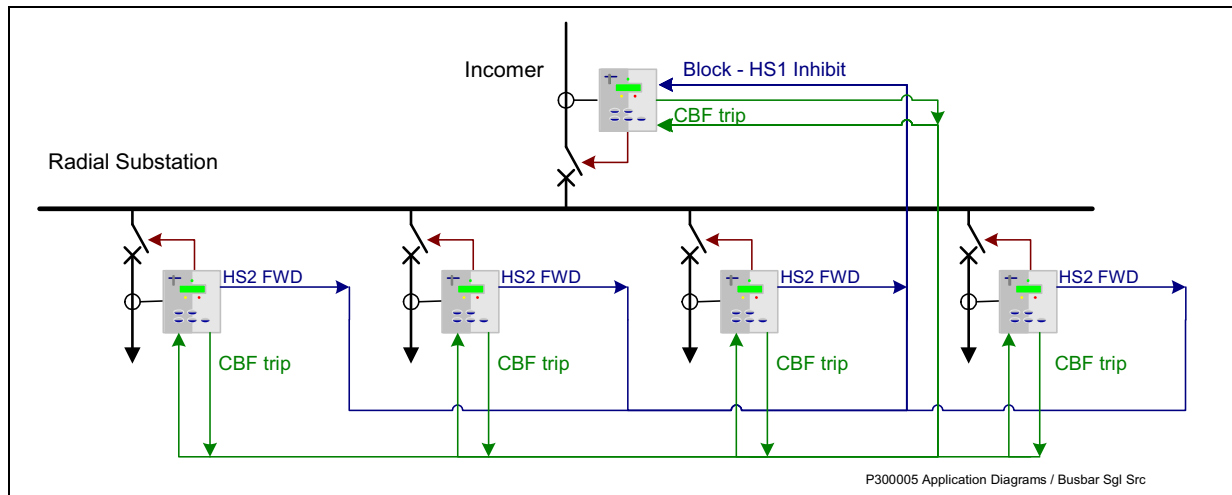
This example shows the use of a “starter” output to block a Highset protection function for a circuit breaker nearer to the source. Type tests have shown that with a time delay as low as 40ms on the upstream Highset function that grading is ensured preventing the upstream relay instigating a trip. For security reasons a minimum time delay of 50ms is recommended, typically 100ms can be used. The Blocking Status input used to inhibit the HighSet function should have 10ms Pick-up and Zero Drop-off delay settings to give fast operation but a.c. pick-up rejection.

The example, shown in Figure 3.4-1, also proposes the use of IDMTL functions grading in the normal manner as back-up protection for a down stream circuit, e.g. due to failure of the circuit breaker to clear a fault.

The combination of blocked lowset or Highset function and IDMTL back-up ensures fast operation for a circuit fault and, provided the IDMTL grading has been correctly calculated and set, will also provide back-up protection.

### Busbar Zone Protection

On a radial substation with a defined incomer a simple logic busbar protection can be applied if each circuit is equipped with an Argus relay, Figure 3.4-2. As above, the Instantaneous Lowset or Highset elements in all relays can be set to the same setting, with the Incomers having 50ms grading delays set. For a fault on any feeder the instantaneous starter contact sends a blocking signal to inhibit operation of the high-speed protection on the incomer (see Figure 3.4-2). This inexpensive logic type protection has been widely applied and has an excellent operating record. However, if any of the outgoing circuits can feed power back on to the busbars, as can happen in an interconnected network, then simple non-directional busbar blocking protection cannot be applied.



**Figure 3.4-2 Busbar Zone Protection with Circuit Breaker Fail using Non-directional Relays. For use on Single-source Feed Networks**

Where a Busbar fault can be back fed via a feeder then directional Argus relays can be installed on each circuit and employed as shown in Figure 3.4-3.

Phase and Earth Fault HighSet 1 elements (HS1) are applied to perform the busbar fault trip function and in all relays, both Feeder and Incomer, are set to the same current setting, above the maximum load current but beneath the minimum fault current, and with a minimum, typically 100ms, grading delay. Each HSI output is mapped to trip its associated Circuit Breaker, therefore, if no block signal is raised then all circuits with current above HS1 setting will be tripped.

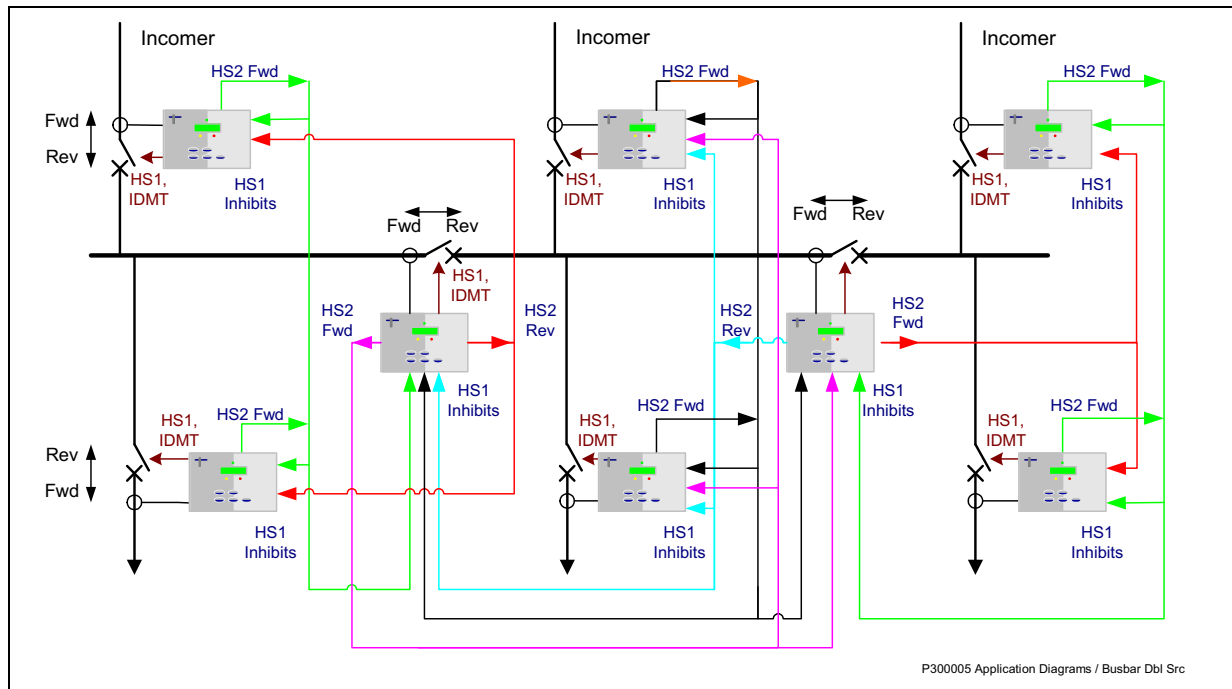
Phase and Earth Fault HighSet 2 Forward elements (HS2) in all relays, both Feeder and Incomer, are set to the same setting and Forward with no delay (instantaneous) and are connected to the block (Inhibit) control line of the HS1 elements on all relays. Thus for faults outside the zone busbar protection all HS1 instantaneous elements will be inhibited. The forward IDMTL function is set to trip a faulted feeder in accordance with the system grading requirement.

With Argus relays a busbar fault trip initiation needs to be delayed by only 50ms, this is sufficient to enable a feeder circuit relay fast start output contact to block the incomer circuit relay should the fault be on a feeder.

Adoption of this philosophy will result in fast clearances of busbar faults coupled with through fault stability.

If Circuit Breaker fail is required then this must be mapped out from each relay into all other relays on the busbar, each relay must accept an external Trip input energised from any other relay; or the CBF outputs must be connected in parallel to a separate common Trip circuit for all Circuit Breakers.





**Figure 3.4-3 Busbar Zone Protection with Circuit Breaker Fail Employing Bi-Directional relays. For use on fully Interconnected Networks with Remote Supply Sources**

If bus coupler and bus section circuit breakers are equipped with CTs and suitable VTs are available, then bi-directional Argus relays can be fitted to those circuits. Suitable steering of blocking and tripping signals can ensure that in the event of a busbar fault only the minimum plant is disconnected from the system. Figure 3.4-3 shows a typical example of this. If there are no CTs on the bus sections/couplers, a staged tripping logic can still be established to achieve the same result, although in a little longer time.

### 3.5 High Impedance Restricted Earth-fault Protection

The SEF/REF element of the Argus can be used to provide high impedance balanced or restricted earth-fault protection as shown in Figure 3.5-1. The SEF/REF starter output is used to provide an instantaneous trip output from the relay.

A separate Siemens Protection Devices Limited. Publication is available covering the calculation procedure for REF protection.

To summarise the calculation:

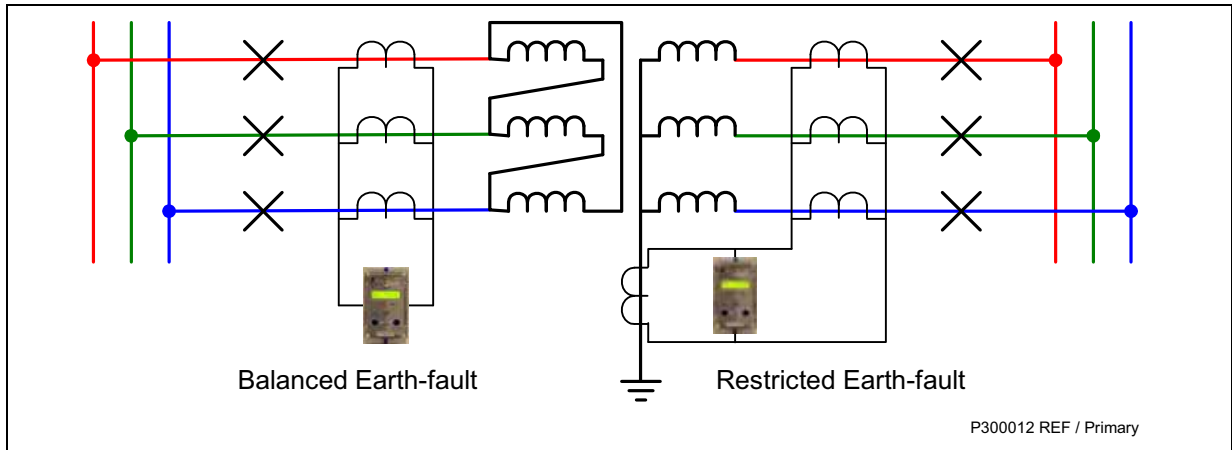
The relay Stability (operating)  $V_s$  voltage is calculated using worst case lead burden to avoid relay operation for through-fault conditions where one of the CTs may be fully saturated. The required fault setting (primary operate current) of the protection is chosen; typically, this is between 10 % and 25 % of the protected winding rated current. The relay setting current is calculated based on the secondary value of the operate current, note, however, that the summated CT magnetising current @  $V_s$  must be subtracted to obtain the required relay operate current setting.

Since the relay operate current setting and stability/operating voltage are now known, a value for the series resistance can now be calculated.

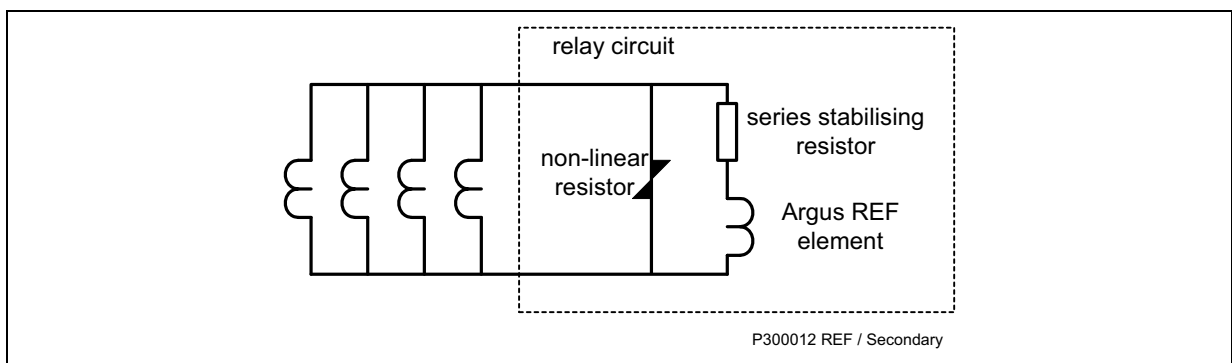
A check is made as to whether a Non-Linear Resistor is required to limit scheme voltage during internal fault conditions – typically where the calculated voltage is in excess of 2kV.

The required thermal ratings for external circuit components are calculated.

Figure 3.5-2 shows the secondary wiring circuit, including the non-linear resistor, if required.

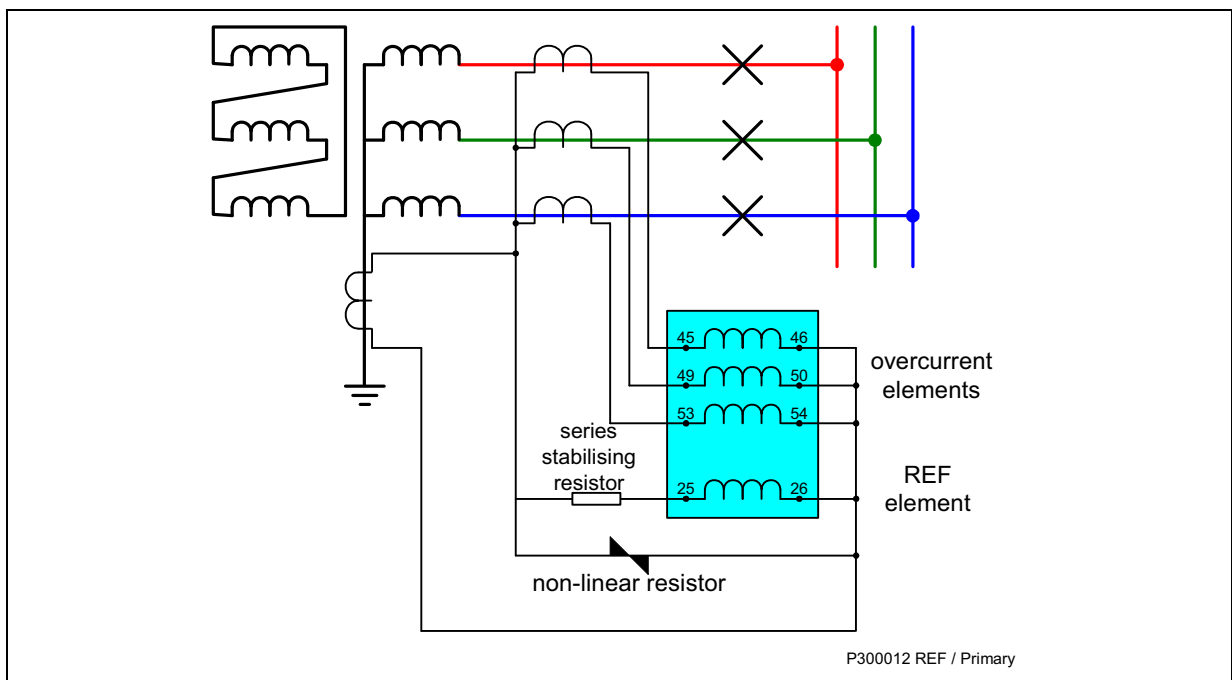


**Figure 3.5-1** Balanced and Restricted Earth-fault protection of Transformers



**Figure 3.5-2** Restricted Earth-fault Secondary Circuit

Composite overcurrent and REF protection can be provided using a multi-element relay as Figure 3.5-3.



**Figure 3.5-3** Composite Overcurrent and Restricted Earth-fault Protection

## 3.6 Circuit Breaker Fail Protection

The Argus relay incorporates a two-stage circuit breaker fail feature. If a designated trip relay operates and the circuit breaker fails to open, the protection algorithm continues to run for as long as current, above the starter level or CBF level detector setting, continues to flow and a continuous trip output is given. This combination of conditions is programmed to start a definite time lag feature designated "CB Fail 1". This function can be programmed to energise an output relay when the C.B. fail time delay is completed. At the same time operation of this timer starts a second time lag feature designated "CB Fail 2" and if the trip outputs already initiated do not stop the current flow through the relay, another relay can be programmed through the output matrix to trip a further breaker e.g. a bus section circuit breaker.

### Schemes

These timers support schemes as follows:

- Single stage CB fail, where all adjacent upstream infeeds are tripped after DTL1 on detection of a CB fail occurrence.
- Two stage CB fail, where stage 1 DTL outputs attempt to re-trip the faulted CB in stage 1 time delay and when this fails the stage 2 time delayed output trips the relevant adjacent infeeds.

The circuit breaker fail feature can also be used to implement a multi-stage tripping scheme. A typical example of this is illustrated in Figure 3.4-2.

### Setting Calculation

The time delay setting applied to the CB fail protection must be in excess of:

the longest CB operate time + relay reset time + a safety margin

Typically, 80 ms + 42 ms + 50 ms = 175ms (approximately)

## 3.7 Auto-reclose Applications

*Argus 4 and Argus 6 only.*

Automatic circuit reclosing is extensively applied to overhead line circuits where a high percentage of faults that occur are of a transient nature and cause no permanent damage to connected plant. The benefits of auto-reclosing are:

- Reduce to a minimum the loss of supply to the customer.
- Allows greater automation of the network with relevant cost savings.
- Instantaneous fault clearance is possible thereby minimising fault damage.

### 3.7.1 Reclose Time Setting

The reclose time is defined as the time between the auto-reclose scheme being energised and the operation of the output contacts that energise the circuit breaker closing circuit. Selection of the optimum time setting is influenced by the recloser characteristics, the type of load supplied, and the nature of the fault.

The recloser mechanism reset time and closing time (interval between energisation of the mechanism and the making of the contacts) or the recloser duty cycle make up the minimum reclose time imposed by the recloser.

Where the connected plant consists of a motor circuit, the motor type must be taken into consideration as regards the requirements of the auto-reclose scheme. Synchronous machines require a reclose time sufficiently long enough to ensure operation of their undervoltage protection, i.e. should not be reconnected. Whilst for induction motors the interruption period needs to be short to enable them to coast until reconnection of the supply.

For overhead lines applications the reclose time must be long enough to allow the ionised air to disperse. Factors that affect the de-ionisation time are the system voltage, cause of the fault, and weather conditions.

### 3.7.2 Reclaim Time Setting

The reclaim time is defined as the time window following a successful closing operation within which if a fault occurs the current reclose sequence will continue. After the Reclaim time if a fault occurs a new sequence will start. Under repetitive fault conditions a long reclaim time in excess of the interval between successive faults may cause unnecessary lockout and interruption of supply.

### 3.7.3 Shots to Lockout Setting

There are no strict guidelines for setting this parameter but a few factors need to be taken into consideration. The recloser design should be taken into account and the system conditions should be examined as to the nature of typical faults. If there is a sufficient percentage of semi-permanent faults which could be burnt away, e.g. fallen branches, a multi shot scheme would be appropriate. Alternatively, if there is a likelihood of permanent faults, a single shot scheme would provide a higher quality of supply.

### 3.7.4 Sequence Auto-reclosing

In Argus 4 & 6 auto-reclose Relays, the low-set overcurrent stage functions as the Instantaneous trip.

Complex sequences may be user programmed to give the best fault clearance strategy.

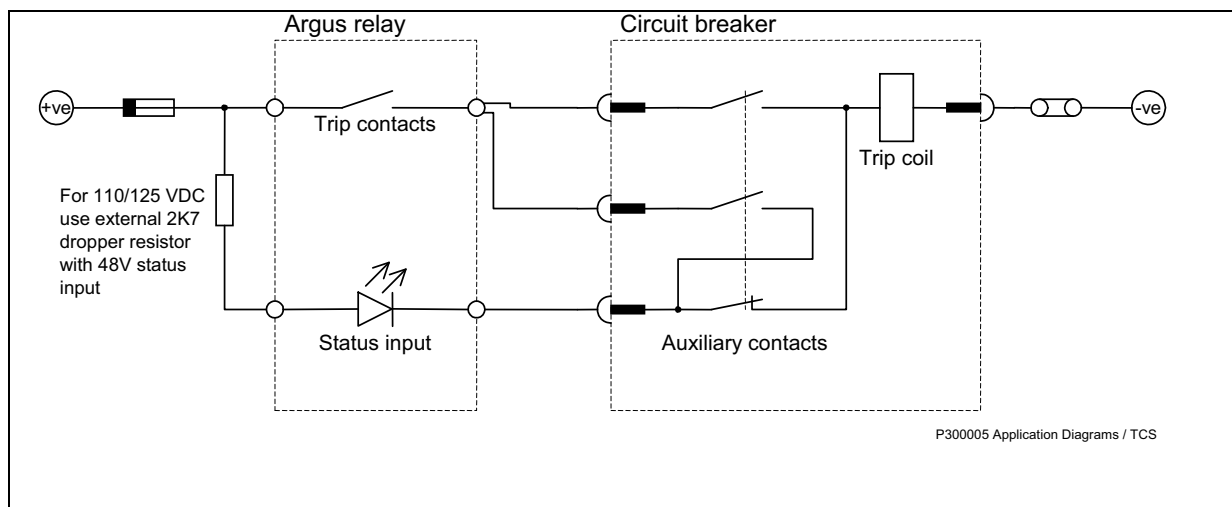
The Argus 4 and 6 relays provide auto-reclosing with sequence co-ordination of the Instantaneous low-set characteristics and Shot Counters. The source low-set is time delayed (i.e. time delayed instantaneous and grading and Sequence Co-ordination with a downstream instantaneous recloser is ensured. Typically, an auto-reclose sequence set to 2 Instantaneous Trips plus one Delayed Trip will restore supplies for 90% of fault conditions.

## 3.8 Trip Circuit Supervision

The Argus relay can be used to supervise one or more trip circuits, via status inputs, with the associated circuit breaker open or closed. A low value of d.c. current is passed through the entire trip circuit to monitor the auxiliary supply, the trip coil, its auxiliary switch, the C.B. secondary isolating contacts and the relevant wiring/links. If the circuit develops a fault and monitoring current flow ceases, the normally energised status input drops off and if it is user programmed to operate one of the output relays, then this relay gives a contact output to signal Trip Circuit Fail. In addition, the LCD display on the Argus relay will indicate "Trip Circuit FAIL".

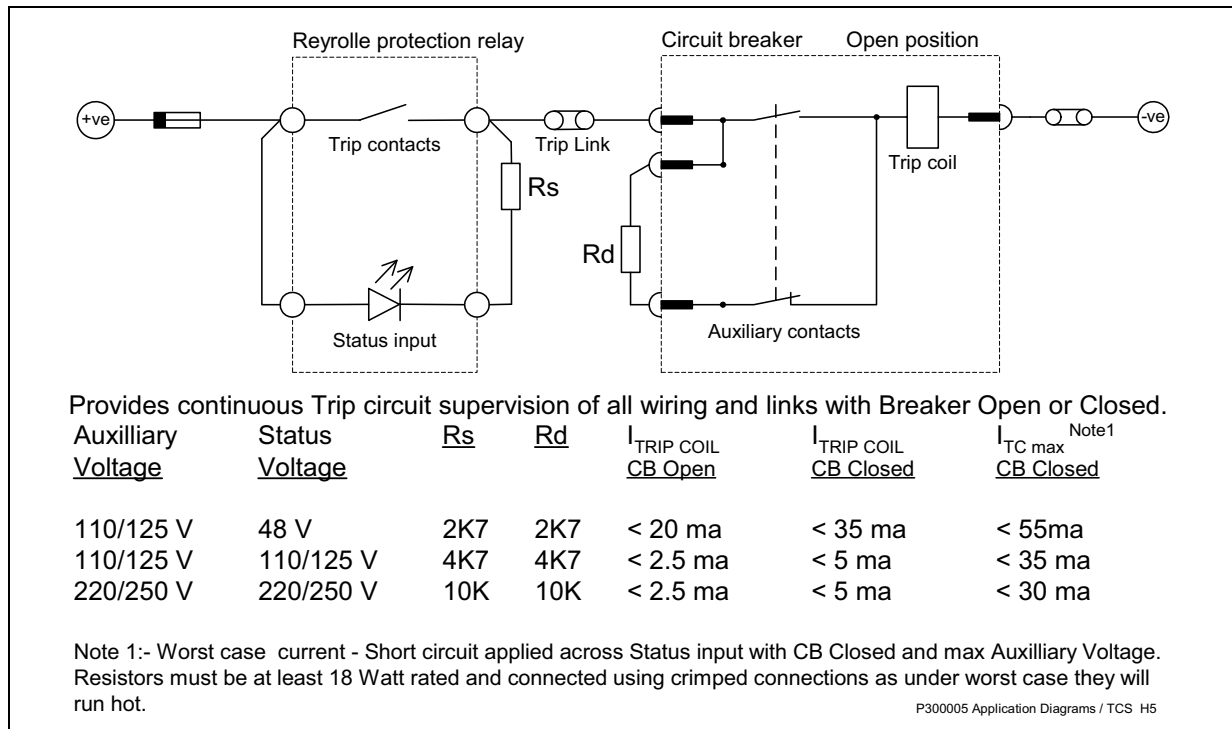
To avoid giving spurious alarm messages while the circuit breaker is operating, the status input should be programmed to have a 400 ms drop-off delay.

Schemes, based on the Electricity Association H6/H5 schemes, are shown below.



**Figure 3.8-1 Engineering Recommendations S.15 H6 Trip Circuit Supervision scheme**

This scheme provides continuous Trip Circuit Supervision of trip coil with circuit breaker Open or Closed. It does not, however, provide pre-closing supervision of the connections and links between the tripping contacts and the circuit breaker.



**Figure 3.8-2 Engineering Recommendations S.15 H5 Trip Circuit Supervision scheme**

This scheme provides continuous, high security, Trip Circuit Supervision of all wiring and links with circuit breaker Open or Closed. Note a TCS Alarm will be generated if the trip contact is latched.

## 3.9 Output Relays

The output relays in the Argus range can be programmed to be self or hand reset. In the hand reset mode, a status input can be programmed to electrically reset the hand reset output relays. In Figure 3.2-1, if the transformers at A and B are, for example, 132 / 33kV or 132 / 11kV and, on the 132kV side there are no local circuit breakers but motor operated isolators, then the reverse characteristic elements can be programmed to operate a hand reset output relay. This relay can be wired to give an intertrip signal and initiate isolator operation. In due course, this output relay can be remotely reset by a status input.

## 3.10 Post-fault Analysis

Argus overcurrent protection relays provide extensive information for post-fault analysis; however, to use this effectively the Argus must be correctly set when put into service. This section describes measures that should be taken to ensure the correct data is captured in the event of a fault.

### 3.10.1 Events, Fault and Waveform Records

Fault records provide textual information on the source of the trip within the Argus, i.e. the element that tripped and any elements that were picked up at the time of trip. This gives the first indication of the type of fault.

However, the fault record should be examined in coordination with the event records to see the full sequence of events leading to a trip. It is possible to identify developing and flashing faults using the event records.

If a waveform record is available, the current waveforms (and voltage waveforms in some models) allow the type of fault to be easily identified. However, the waveform record lasts only 1 second, whereas the event records will cover many seconds or minutes. If a fault is of a flashing nature this will be apparent from the event records, while the waveform record may show only the final overcurrent leading to trip.

### 3.10.2 Fault triggers

In order to generate a fault record it is important that the fault trigger is correctly set. A fault will be recorded if any element trips and it is mapped to an output relay that is defined as a fault trigger relay. Therefore, any output relay that trips a circuit breaker should be set as a fault trigger relay using the `Data Storage:Fault Trigger` setting. In addition, if it is required to record a fault for any other element, an output relay driven by that element should also be defined as a fault trigger relay.

### 3.10.3 Waveform triggers

In order to generate a waveform record on occurrence of a fault it is important that the waveform trigger is correctly set. Each type of fault (phase-fault, earth-fault or SEF) for which it is required to record a waveform must be set using the Data Storage:Waveform Trig setting. This setting also allows waveform triggering to be enabled from external sources using the status inputs. If external waveform triggering is required the status input must also be correctly set using the Status Config:Waveform Trig setting.

When the source of waveform triggers has been selected consideration should be given to the pre-trigger recording. Each waveform is 1 second long, therefore, for a delayed element, the current could be present for a few hundred milliseconds (or over 1 second) before a trip occurs. Following the trip output it is likely that the current will continue to be present for one to two hundred milliseconds before the circuit breaker interrupts the current.

The Data Storage:Waveform Pre-Trigger setting allows a percentage, typically 80%, of the 1 second to be allocated to pre-trigger recording. The user should consider the application, the likely fault type, and the area of greater interest (inception of fault or post-trip waveform) when applying this setting,

### 3.10.4 ReyDisp (IEC 60870-5-103)

The Reydisp Evolution software allows the recorded data (events, fault records, waveform records) to be uploaded from the Argus to a PC for analysis. When saving data it is important to save the applied settings at the time of trip, in order to correctly interpret the data.

#### **Get All Data**

The ReyDisp 'Get All Data' command allows all data to be easily uploaded from the Argus.

If this command is selected ReyDisp will ask the user to specify a directory name (which will be created if it does not exist) and will then upload all events, all 5 fault records, all 5 waveform records and all settings from all 8 settings groups.

This ensures that all necessary data is available for post-fault analysis.

## Section 4: Communication Interface

### 4.1 Introduction

Argus relays can communicate with controlling systems using either IEC60870-5-103 or MODBUS communications protocols. The protocol is selectable in the relay settings menu.

#### 4.1.1 Comms Protocol Setting

The relay protocol can be selected from a default setting of IEC60870-5-103 to Modbus RTU whichever is required. The `Communications Interface:Comms Protocol` setting should match that of any communicating device.

### 4.2 IEC 60870-5-103

Argus relays can communicate with control and automation systems, or with PCs running ReyDisp software, to provide operational information, post-fault analysis and settings interrogation and editing. This section describes how to use the IEC 60870-5-103 compliant Informative Communication Interface with a control system or interrogating computer. Appropriate software within the control system or on the interrogating computer (e.g. ReyDisp Evolution) is required to access the interface.

This section specifies connection details provided in the Argus relays. For further information regarding the interface reference should be made to the separate Informative Communications Interface manual (reference 434/TM/5), which covers all Reyrolle products. See website [www.siemens.com/energy](http://www.siemens.com/energy)

The same communications interface is used to provide control system connections and for dialogue communications by the protection engineer. An appropriate IEC 60870-5-103 control system interface will be required for the former application, while the latter is provided by ReyDisp Evolution software.

#### 4.2.1 Physical Connection

The Argus complies with the physical requirements of IEC 60870-5-103 using fibre-optics however it is possible to apply more flexible, but non-compliant, settings for connection to PCs etc.

#### 4.2.2 Medium

The communicating medium is optical fibre. The device communicating with the Argus should have a fibre-optic interface, preferably optimised for 62.5/125 µm glass fibre. If the communicating device, e.g. a PC, has an RS232C electrical interface, a fibre-optic to RS232 converter is required.

##### 4.2.2.1 Sigma Fibre-optic to RS232 Converters

Siemens Protection Devices Limited, can provide a range of fibre-optic to RS232 converter devices:

- Sigma 1 – a panel mounting fibre-optic star coupler, for up to 29 slaves. An RS232 port is available at the front of the device. By default, communication is to the master fibre connections on the rear, however communication is automatically switched to the front RS232 port when a communicating programme is activated on it. Each fibre-optic port can be individually selected between 'Light On' and 'Light Off' (see section 0).
- Sigma 3 – a panel mounting fibre-optic to RS232 converter. Two RS232 ports are available, one at the rear for connection to a modem, and one at the front for connection to a local PC. By default the rear port is active, however, communication is automatically switched to the front port when a communicating programme is activated on it. The fibre-optic port can be selected between 'Light On' and 'Light Off' (see section 0).
- Sigma 4 – a loose fibre-optic to RS232 converter.

Full details of the above devices can be found by referring to the website [www.siemens.com/energy](http://www.siemens.com/energy)

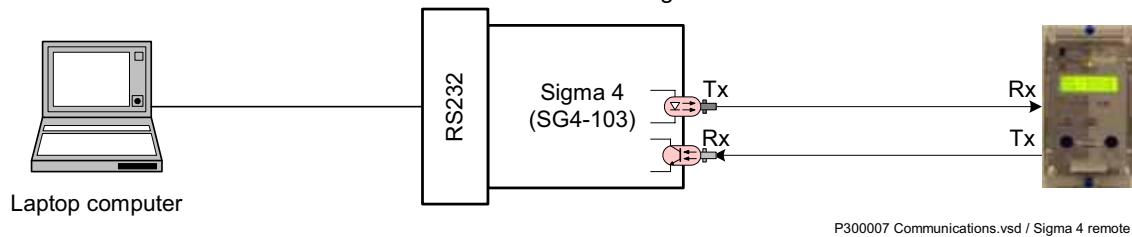
#### 4.2.3 Recommended cable

Selection of fibre-optic cable is important. Fibres must be terminated with ST<sup>TM</sup> (BFOC/2.5) connectors.

The recommended type is 62.5/125µm glass fibre. Communication distances over 1 km are achievable using this type of fibre.

## 4.2.4 Network Topology

Communication networks can be connected either in star or ring format.



## 4.2.5 Figure 4.2-1 Settings

Communication parameters of Communications Interface:Comms Baud Rate, Communications Interface:Comms Parity and Communications Interface: Line Idle should match those of the communicating device.

## 4.2.6 IEC Class II Measurands

Class II measurands can be sent as either ASDU 3 (reports 1 current channel) or ASDU 9 (reports 9 channels, Ia, Ib, Ic, Va, Vb, Vc, P, Q). The values are returned as a fraction of a nominal value ie 1A, 63.5v. The Communications Interface:IEC Class II Measurand setting should be set as appropriate for each system.

## 4.2.7 IEC Class II Update period

The class II measurand is updated in the relay at a period dependant on the Communications Interface:Class 2 Update Period setting. This ranges from instantaneous (constantly updated) to every 60s (updated every minute).

## 4.2.8 IEC Class II scaling

The measurands returned are fractions of nominal system quantities. The maximum range of the measurand can be set either 1.2 or 2.4 times the nominal. Values that exceed this range will be returned as the maximum value and flagged overflow. Note using 2.4 times scaling will double the range but half the resolution per bit. The Communications Interface: IEC Class II Scaling setting should be set as appropriate for each system.

## 4.2.9 Baud Rate

Rates of 19200, 9600, 4800, 2400, 1200, 600, 300, 150, 110 and 75 bits per second are provided. However, only 19200 and 9600 are defined in IEC 60870-5-103, the additional rates are provided for local or modem communications.

The Communications Interface:Comms Baud Rate setting should match that of the communicating device, e.g. P.C.

## 4.2.10 Comms Parity

IEC 60870-5-103 defines transmission as using Even parity, however, in some instances an alternative may be required. The Communications Interface:Comms Parity setting allows parity of None to be selected. This setting should match that of the communicating device, e.g. PC.

## 4.2.11 Relay Address

Each relay on a network must have a unique address, between 1 and 254, as set by the Communications Interface:Relay Address setting. A relay with the default address of 0 will not be able to communicate.

## 4.2.12 Line Idle

The IEC60870-5-103 protocol defines a line idle state of Light On. Binary '0' is represented by light on, binary '1' is represented by light off, and when a device is not communicating it idles with the light on (sending '0'). This allows detection of a broken fibre condition. When the line is idling, a binary '0' should be received constantly. If binary '1' is received constantly, then no light is being received, hence the fibre may be broken.

The Communications Interface: Line Idle setting must be set to be either on or off to be compatible with the communicating device connected to the relay.



### 4.2.13 Data Echo

Argus relays may be connected in a ring, e.g. as shown in Fig.4.3. The optical ring architecture requires data to be passed from one relay to the next, therefore, when using this method, all relays in the ring must have the Communications Interface>Data Echo setting to On.

For Argus with individual connections (e.g. Figure 1.5-1 **Error! Reference source not found.**), or connected in a star topology (e.g. Figure 4), the setting should be set to Off.

**Table 4-1 Communications Settings**

Sub-menu: **Communications Interface**

Setting name	Range ( <b>bold</b> = default)	Units	Notes
<b>Comms Protocol</b>	<b>IEC 60870-5-103</b> , MODBUS-RTU		
<b>IEC Class 2 Measurand</b>	<b>ASDU 3</b> , ASDU 9		
<b>Class 2 Update Period</b>	<b>INST</b> , 1, 2 .. 60	Sec	
<b>IEC Class 2 Scaling</b>	<b>1.2x</b> , 2.4x		
<b>Comms Baud Rate</b>	75, 110, 150, 300, 600, 1200, 2400, 4800, 9600, <b>19200</b>	baud	
<b>Comms Parity</b>	NONE, <b>EVEN</b>		
<b>Relay Address</b>	<b>0</b> , 1...254		
<b>Line Idle</b>	LIGHT ON, <b>LIGHT OFF</b>		
<b>Data Echo</b>	<b>OFF</b> , ON		

### 4.2.14 Modems

The communications interface has been designed to allow data transfer via modems. However, IEC 60870-5-103 defines the data transfer protocol as an 11 bit format of 1 start, 1 stop, 8 data and even parity, which is a mode most commercial modems do not support. High performance modems will support this mode.

### 4.2.15 Connecting a Modem to the Relay(s)

RS232C defines devices as being either Data Terminal Equipment (DTE) e.g. computers, or data Communications Equipment (DCE), e.g. modems, where one is designed to be connected to the other. In this case, two DCE devices (the modem and the fibre-optic converter) are being connected together, so a null terminal connector is required, which switches various control lines. The fibre-optic converter is then connected to the relay network Tx to Relay Rx and Rx to Relay Tx.

### 4.2.16 Setting the Remote Modem

The exact settings of the modem are dependent on the type of modem. Although most modems support the basic Hayes 'AT' command format, different manufacturers use different commands for the same functions. In addition, some modems use DIP switches to set parameters, others are entirely software configured.

Before applying the following settings, the modem's factory default settings should be applied, to ensure it is in a known state.

Several factors must be considered to allow remote dialling to the relays. The first is that the modem at the remote end must be configured as auto answer. This will allow it to initiate communications with the relays. Next, the user should set the data configuration at the local port, i.e. baud rate and parity, so that communication will be at the same rate and format as that set on the relay and the error correction is disabled.

Auto-answer usually requires two parameters to be set. The auto-answer setting should be switched on and the number of rings after which it will answer selected. The Data Terminal Ready (DTR) settings should be forced on. This tells the modem that the device connected to it is ready to receive data.

The parameters of the modem's RS232C port are set to match those set on the relay, set baud rate and parity to be the same as the settings on the relay and number of data bits to be 8 and stop bits 1. Note, although the Argus may be able to communicate with the modem at say 19200 bps, the modem may only be able to transmit over the telephone lines at 14400 bps. Therefore, a baud rate setting on which the modem can transmit should be chosen. In this example, a baud rate of 9600 should be chosen.

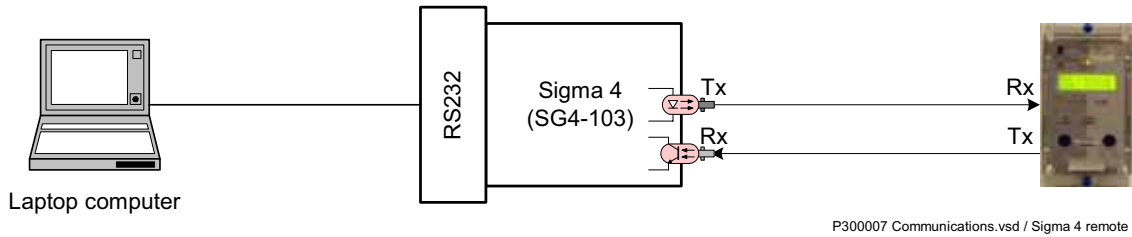
As the modems are required to be transparent, simply passing on the data sent from the controller to the device and vice versa, error correction and buffering should be turned off.

If possible Data Carrier Detect (DCD) should be forced on, as this control line will be used by the Fibre-optic converter.

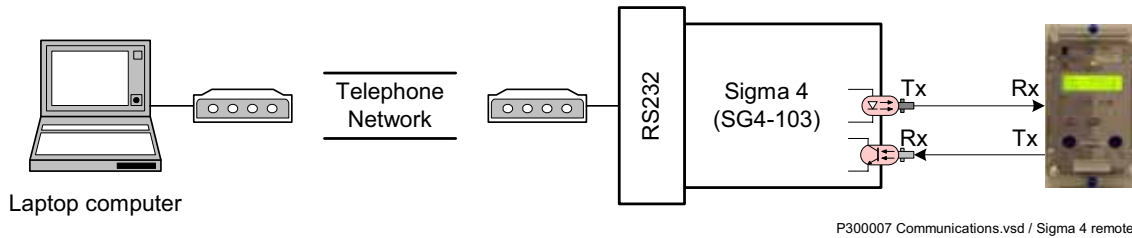
Finally, these settings should be stored in the modem's memory for power on defaults.

### 4.2.17 Connecting to the Remote Modem

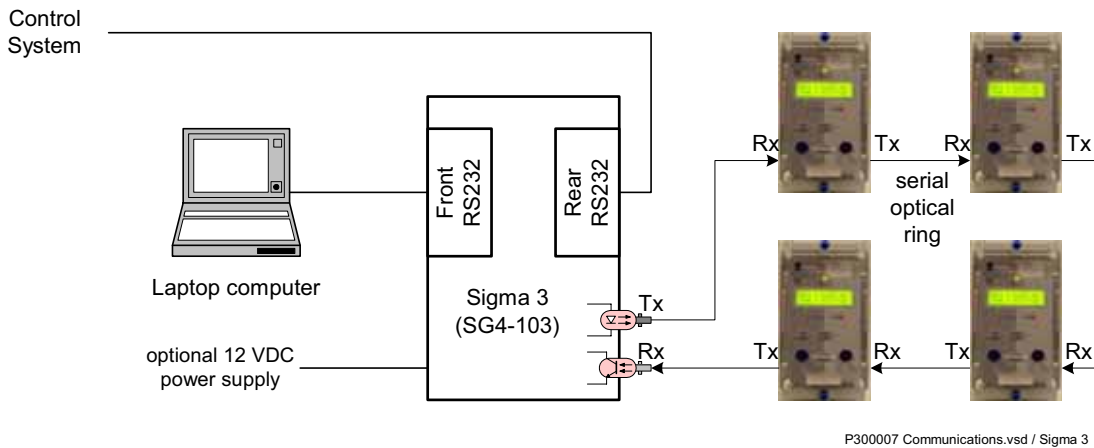
Once the remote modem has been configured correctly it should be possible to dial up the modem and make connection to the relay. As the settings on the remote modem are fixed the local modem should negotiate with it on connection choosing suitable matching settings. If it cannot do this, the local modem should be set with settings equivalent to those of the remote modem as described above.



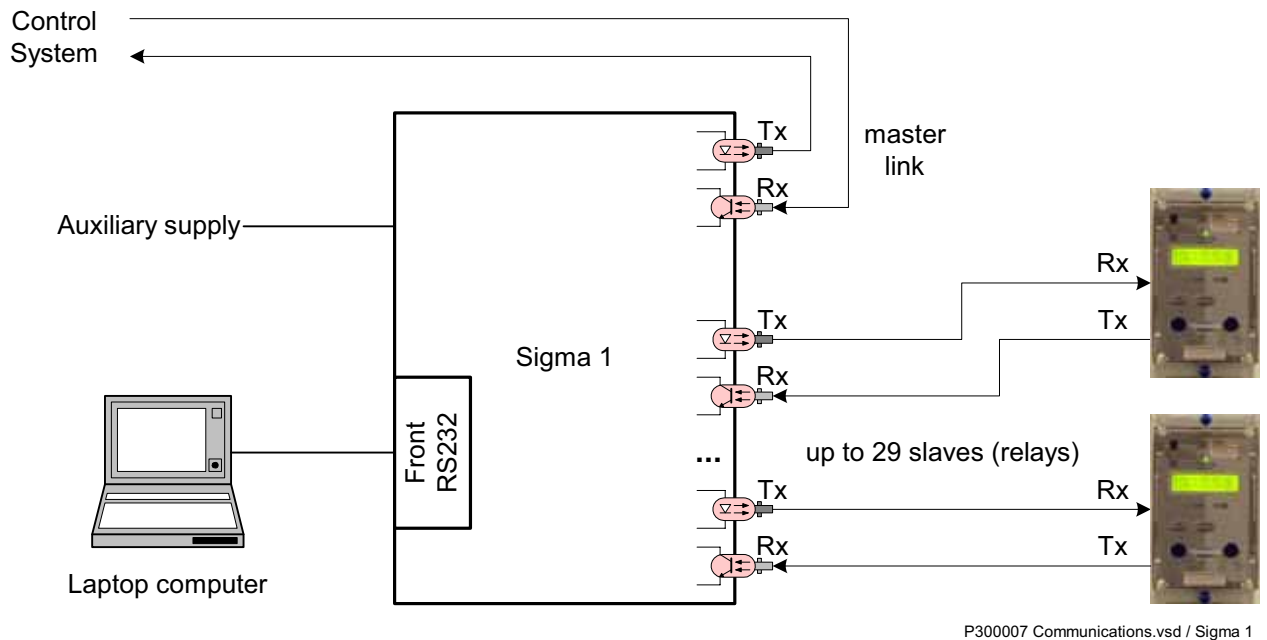
**Figure 4.2-1 Communication to Argus Relay using Sigma 4 (Local Connection)**



**Figure 4.2-2 Communication to Argus Relay using Sigma 4 and Modem**



**Figure 4.2-3 Communication to Multiple Argus Relays from Control System and Laptop with Sigma 3 and Fibre-optic Ring Network**



**Figure 4.2-4 Communication to Multiple Argus Relays from Control System and Laptop with Sigma 1 and Fibre-optic Star Network**

## 4.3 Introduction – Modbus RTU

This section describes how to use the Modbus Interface with a compliant control system. For further information regarding the interface, reference should be made to the Argus Modbus implementation report 434/TIR/14 available on website [www.siemens.com/energy](http://www.siemens.com/energy)

The same communications interface is used to provide control system connections.

The Argus complies with the physical requirements of Modbus using fibre-optics or an RS485 interface.

### 4.3.1 Medium

The communicating medium is optical fibre or electrical RS485. The device communicating with the Argus should have an interface optimised for 62.5/125  $\mu$ m glass fibre-optics, or RS485 electrical connection.

#### 4.3.1.1 Sigma Fibre-optic to RS232 Converters

See previous section 4.2.2.1.

### 4.3.2 Recommended cable

Selection of fibre-optic cable is important. Fibres must be terminated with ST<sup>TM</sup> (BFOC/2.5) connectors. The recommended type is 62.5/125 $\mu$ m glass fibre. Communication distances over 1 km are achievable using this type of fibre.

The RS485 electrical interface can be connected using 120 ohm screened twisted pair wire i.e. Belden 9841 or equivalent.

### 4.3.3 Network Topology

Fibre optical communication networks can be connected singularly or in a star configuration. Modbus does not support a fibre optic ring configuration.

RS485 electrical connection can be used in a single or multi-drop configuration. The last device must be terminated correctly.

Figure 4.2-1 & Figure 4.2-4 illustrate typical network arrangements.

#### 4.3.4 Settings

Communication parameters of Communications Interface:Comms Baud Rate, Communications Interface:Comms Parity and Communications Interface:Line Idle should match those of the communicating device.

#### 4.3.5 Comms Protocol

See previous section 4.1.1

#### 4.3.6 Baud Rate

Rates of 19200, 9600, 4800, 2400, 1200, 600, 300, 150, 110 and 75 bits per second are provided.

The Communications Interface:Comms Baud Rate setting should match that of the communicating device,

#### 4.3.7 Comms Parity

The Communications Interface:Comms Parity setting allows parity of Even or None to be selected. This setting should match that of the communicating device.

#### 4.3.8 Relay Address

Each relay on a network must have a unique address, between 1 and 247, as set by the Communications Interface:Relay Address setting. A relay with the default address of 0 will not be able to communicate. The actual number of devices will be limited to 32 devices on any one RS485 connection.

#### 4.3.9 Line Idle

If the communication medium is fibre-optic the Communications Interface:Line Idle setting defines the quiescent state. When set as Light On binary '0' is represented by light on, binary '1' is represented by light off and vice versa for Light Off mode. While in Light On mode and the device is not communicating it maintains the Light On mode to allow breaks in the cable to be detected. These potential breaks would not be detected when the device mode is set to Light Off.

This must be set to OFF when connected to the RS485 electrical connection.

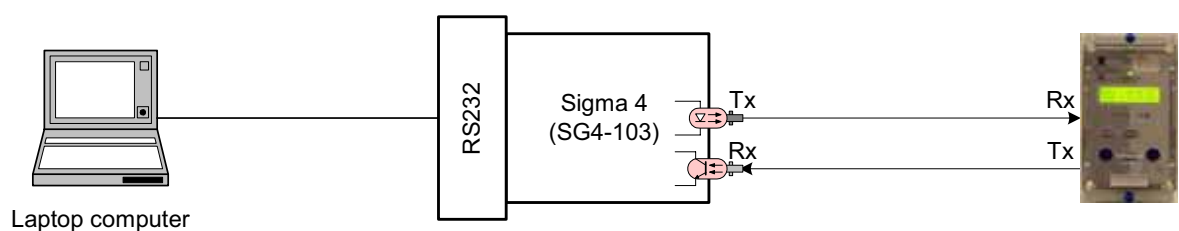
#### 4.3.10 Data Echo

All relays must have the Communications Interface:Data Echo setting to OFF.

**Table 4-2 Communications Settings**

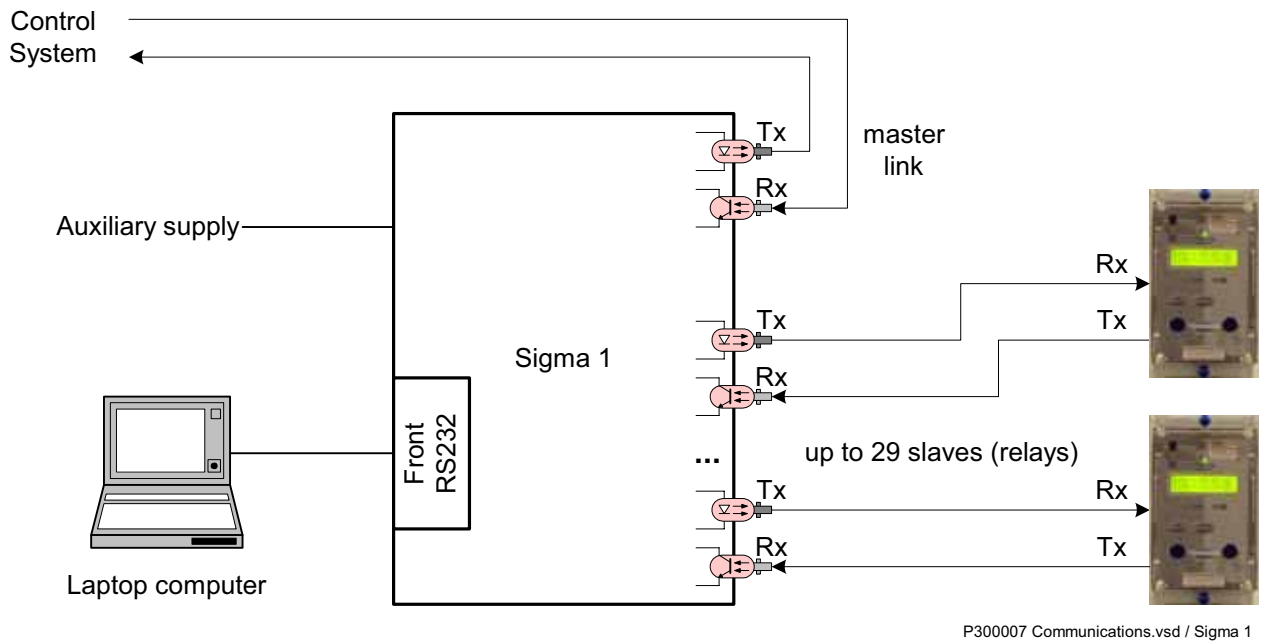
Sub-menu: **Communications Interface**

Setting name	Range ( <b>bold = default</b> )	Units	Notes
<b>Comms Protocol</b>	<b>IEC 60870-5-103</b> , MODBUS-RTU		
<b>Comms Baud Rate</b>	75, 110, 150, 300, 600, 1200, 2400, 4800, 9600, <b>19200</b>	baud	
<b>Comms Parity</b>	NONE, <b>EVEN</b>		
<b>Relay Address</b>	<b>0</b> , 1...254		
<b>Line Idle</b>	LIGHT ON, <b>LIGHT OFF</b>		
<b>Data Echo</b>	<b>OFF</b> , ON		

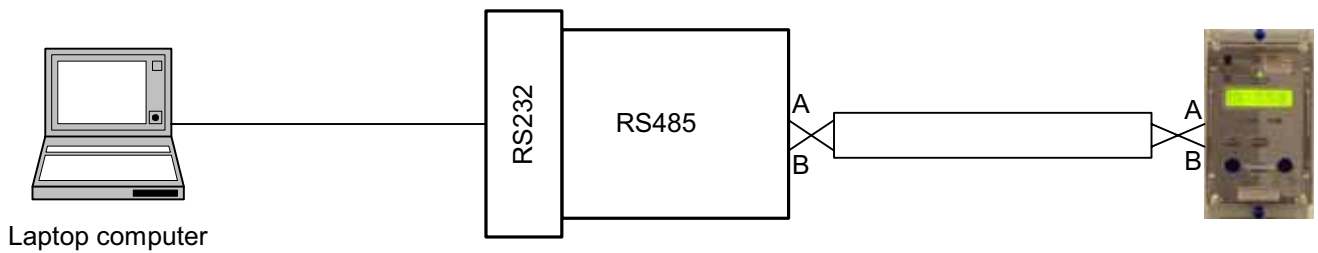


P300007 Communications.vsd / Sigma 4 remote

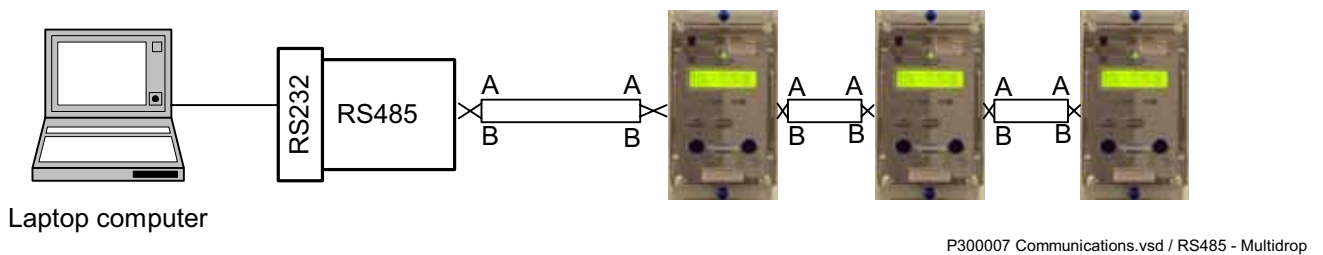
**Figure 4.3-1 Communication to Argus Relay using Sigma 4 (Local Connection)**



**Figure 4.3-2 Communication to Multiple Argus Relays from Control System and Laptop with Sigma 1 and Fibre-optic Star Network**



**Figure 4.3-3 Communication to Argus Relay using RS485 – RS232 converter (Local Connection)**



**Figure 4.3-4 Communication to Argus Relay using RS485/RS232 converter (Multidrop Connection)**

### 4.3.11 Glossary

**Baud Rate**

See bits per second.

**Bit**

The smallest measure of computer data.

**Bits Per Second (BPS)**

Measurement of data transmission speed.

**Data Bits**

A number of bits containing the data. Sent after the start bit.

**Half-Duplex Asynchronous Communications**

Communications in two directions, but only one at a time.

**Hayes 'AT'**

Modem command set developed by Hayes Microcomputer products, Inc.

**Modem**

MOdulator / DEModulator device for connecting computer equipment to a telephone line.

**Parity**

Method of error checking by counting the value of the bits in a sequence, and adding a parity bit to make the outcome, for example, even.

**Parity Bit**

Bit used for implementing parity checking. Sent after the data bits.

**RS232C**

Serial Communications Standard. Electronic Industries Association Recommended Standard Number 232, Revision C.

**Start Bit**

Bit (logical 0) sent to signify the start of a byte during data transmission.

**Stop Bit**

Bit (logical 1) sent to signify the end of a byte during data transmission.

# 7SG11Argus

Overcurrent Protection Relays

## Document Release History

This document is issue 2010/02. The list of revisions up to and including this issue is:

Pre release

2010/02	Document reformat due to rebrand
2006/03	Third issue: Editorial modifications, software revision histories updated
2004/05	Second issue: Modification of CBF feature, software release updated, Modbus protocol included, connection diagram for new models
2002/12	First issue

The copyright and other intellectual property rights in this document, and in any model or article produced from it (and including any registered or unregistered design rights) are the property of Siemens Protection Devices Limited. No part of this document shall be reproduced or modified or stored in another form, in any data retrieval system, without the permission of Siemens Protection Devices Limited, nor shall any model or article be reproduced from this document unless Siemens Protection Devices Limited consent.

While the information and guidance given in this document is believed to be correct, no liability shall be accepted for any loss or damage caused by any error or omission, whether such error or omission is the result of negligence or any other cause. Any and all such liability is disclaimed.

## Software Release History

The software listed below is used in one of more types Argus relay. The list of software revisions applying to Argus 1, up to and including this document issue is:

Nov 2005	2434H80023 R10	Highset and Lowset setting steps revised between 2.5xIn and 3.0xIn
July 2005	2434H80023 R9	ACD bit in IEC 60870 library corrected
Mar 2005	2434h80023 R8	CBF logic modified, timer will run while trip is being issued and I > ICBF
Aug 2004	2434H80023 R7	Modification to "checking settings" screen at switch on. Corrected "CT Failure" setting display when configured to show PRIMARY/SECONDARY Amps. ASDU4 measurands return value 0 correctly.
April 2004	2434H80023 R6	Minimum setting for P/F – E/F elements now 0.05 xIn
Jan 2004	2434H80023 R5	Additional features: Modbus added Additional features: CT Failure function added Minor change: IEC60870 Class 2 measurands
Sep 2003	2434H80023 R4	Additional features: CBF Level detectors added Minor change: DTL timers extended to 5 minutes
Mar 2003	2434H80023 R3	Minor change: Time synch via IEC870
Nov 2002	2434H80023 R2	Minor change: communications with Reydisp
Jun 2002	2434H80023 R1	Minor change: power on alarm added
Feb 2002	2434H80022 R3	Additional features: CB fail (all models).
Oct 2001	2434H80022 R2	Additional features: external trip via status input. Minor change: SEF 2 <sup>nd</sup> stage can be disabled.
Feb 2001	2434H80022 R1	Additional features: general alarms, status input inversion, resettable instruments, output relay pulse length setting, 10 second delay on trip test. Additional features: CB fail, trip circuit supervision (single-pole models).
Jan 2000	2434H80021 R5	Minor change: current meter averaging.
Jul 1999	2434H80021 R4	Minor change: status group select
May 1999	2434H80021 R3	Additional features: default instruments
Mar 1998	2434H80020 R1	Additional features: new expansion board (8SI). Additional features: clock synchronisation using status input
Sep 1997	2434H80019 R4	Minor change: settings displayed in ReyDisp
Jul 1997	2434H80019 R3	Additional features: status input pick-up and drop-off delays added. Additional features: CB fail, trip circuit supervision (all expanded I/O models). Minor change: separate settings for P/F, E/F and SEF current ratings. Minor change: sum of I <sup>2</sup> setting range.
Apr 1997	2434H80018 R2	Additional features: CB fail, trip circuit supervision (some models). Additional features: reset of latched output relays by status input.
Jan 1997	2434H80024...7 R2	Minor change: event numbers.
Oct 1996	2434H80024...7 R1	Additional features: new status input functions: setting group select, all algorithms can be inhibited. Additional features: first version with I/O expansion card (4SI+4OR).
Mar 2000	2434H80002...7 R17	Minor change: current meter averaging.
Mar 1998	2434H80002...7 R16	Minor change: real time clock.
Jan 1997	2434H80002...7 R15	Minor change: settings group changes delayed until no protection elements are operating.



Oct 1996	2434H80002...7 R13	Minor change:	communications parity setting added.
Jul 1996	2434H80002...7 R12	Minor change:	user must press enter after factory defaults applied.
Jun 1996	2434H80002...7 R10	Minor change:	sum of I <sup>2</sup> setting range.
		Minor change:	output relay minimum energise time reduced from 200 to 100 ms.
		Minor change:	'factory defaults' display.
Apr 1996	2434H80002...7 R8	Minor change:	fault record text for characteristic element.
		Minor change:	copy group setting default.
		Minor change:	fault record text for characteristic element.
Apr 1996	2434H80002...7 R7	Minor change:	relay information provided in communications.
		Minor change:	communication baud rates.
Apr 1996	2434H80002...7 R6	Minor change:	IDMTL starter drop-off, and relay reset timer.
		First release	

## Hardware Release History

The Argus hardware is used in many different relays. The list of hardware revisions applying to Argus 1, up to and including this document issue is:

Feb 2004	Additional model:	4 pole variant with 3 status inputs and 5 output relays
Mar 2002	Appearance change:	modification to grey fascia design – logo, dark grey band, buttons and label.
Jan 2002	External change:	SMA fibre-optic connectors replaced by ST <sup>TM</sup> (BFOC/2.5) by default.
Jul 1999	Appearance change:	introduction of grey fascia design to replace existing black fascia.
Jul 1999	External change:	introduction of Epsilon case and terminal blocks
Mar 1998	Additional features:	introduction of new expansion board (8SI).
Apr 1997	Internal change:	introduction of additional memory
Oct 1996	Additional features:	introduction of I/O expansion card (4SI+4OR).
Nov 1995	First release	

## Contents

<b>Software Release History</b> .....	<b>2</b>
<b>Hardware Release History</b> .....	<b>4</b>
<b>Contents</b> .....	<b>5</b>
<b>List of Figures</b> .....	<b>5</b>
<b>Section 1: Variants</b> .....	<b>6</b>
<b>Section 2: Settings</b> .....	<b>11</b>
<b>Section 3: IEC 60870-5-103 &amp; Modbus RTU Definitions</b> .....	<b>16</b>
3.1 IEC 60870-5-103 Definitions .....	16
3.2 Modbus RTU Definitions .....	23
<b>Section 4: Application Diagrams</b> .....	<b>29</b>

## List of Figures

Figure 2-1 Status Input and Output Relay Programming Matrix .....	15
Figure 4-1 Typical Connection for Earth-fault Protection .....	29
Figure 4-2 Typical Connection for Sensitive Earth-fault Protection .....	30
Figure 4-3 Typical Connection for 3 Phase-fault Protection .....	30
Figure 4-4 Typical Connection for 2 Phase-fault and Earth-fault Protection .....	31
Figure 4-5 Typical Connection for 2 Phase-fault and Sensitive Earth-fault Protection .....	31
Figure 4-6 Typical Connection for 3 Phase-fault and Earth-fault Protection .....	32
Figure 4-7 Typical Connection for 2 Phase-fault, Earth-fault and Sensitive Earth-fault Protection .....	32
Figure 4-8 Typical Connection for 3 Phase-fault and Sensitive Earth-fault Protection .....	33
Figure 4-9 Typical Connection for 3 Phase-fault and Earth-fault Protection – 1A or 5A Version .....	33

## Section 1: Variants

This document applies to the Argus relays listed in the following MLFB Structure & table.

The MLFB Structure references the complete number for each relay:

- 7SG11nn-nxxnn-nxA0

where n is a digit and x is a letter.

The table uses two references for most relays, each of which is valid:

- an 'Order code' of the form AGn-nnn, and
- a 'Type' of the form DCDnnnX

where n is a digit and X is a letter.

Protection	Application Diagram	I/O	Order code / Type				
			30/48 aux.		110/220 aux.		
			30V status	48V status	48V status	110V status	220V status
Single phase-fault or earth-fault	Figure 4-1	1 SI 7 OR	DCD111A	<b>AG1-101</b> DCD113A	<b>AG1-102</b> DCD114A	DCD115A	DCD116A
Sensitive earth-fault	Figure 4-2	1 SI 7 OR	DCD121A	<b>AG1-103</b> DCD123A	<b>AG1-104</b> DCD124A	DCD125A	DCD126A
3 phase-fault, or 2 phase-fault and earth-fault	Figure 4-3	1 SI 7 OR	DCD311A	<b>AG1-301</b> DCD313A	<b>AG1-302</b> DCD314A	DCD315A	DCD316A
	Figure 4-4	5 SI 11 OR	DCD311B	<b>AG1-311</b> DCD313B	<b>AG1-312</b> DCD314B	DCD315B	DCD316B
		9 SI 7 OR	DCD311C	<b>AG1-321</b> DCD313C	<b>AG1-322</b> DCD314C		DCD315C
2 phase-fault and SEF	Figure 4-5	1 SI 7 OR	DCD321A	<b>AG1-303</b> DCD323A	<b>AG1-304</b> DCD324A		DCD325A
		5 SI 11 OR	DCD321B	<b>AG1-313</b> DCD323B	<b>AG1-314</b> DCD324B		
		9 SI 7 OR	DCD321C	<b>AG1-323</b> DCD323C	<b>AG1-324</b> DCD324C		
3 phase-fault and earth-fault	Figure 4-6	1 SI 7 OR	DCD411A	<b>AG1-401</b> DCD413A	<b>AG1-402</b> DCD414A	DCD415A	DCD416A
		5 SI 11 OR	DCD411B	<b>AG1-411</b> DCD413B	<b>AG1-412</b> DCD414B	DCD415B	DCD416B
		9 SI 7 OR	DCD411C	<b>AG1-421</b> DCD413C	<b>AG1-422</b> DCD414C	DCD415C	DCD416C
3 phase-fault and earth-fault 1A		3 SI 5 OR		<b>AG1-431</b>	<b>AG1-433</b>		
3 phase-fault and earth-fault 5A		3 SI 5 OR		<b>AG1-432</b>	<b>AG1-434</b>		
3 phase-fault and SEF, or 2 phase-fault, earth-fault and SEF	Figure 4-8	1 SI 7 OR	DCD421A	<b>AG1-403</b> DCD423A	<b>AG1-404</b> DCD424A	DCD425A	DCD426A
	Figure 4-7	5 SI 11 OR	DCD421B	<b>AG1-413</b> DCD423B	<b>AG1-414</b> DCD424B	DCD425B	DCD426B
		9 SI 7 OR	DCD421C	<b>AG1-423</b> DCD423C	<b>AG1-424</b> DCD424C	DCD425C	DCD426C

# Ordering Information – 7SG111 Argus 1

Product description	Variants	Order No.
<p>Nondirectional O/C relay</p> <p>Over current and earth fault protection for radial feeders, capacitor banks and industrial and commercial plant.</p>	<p><u>Number of elements</u> Single pole relay</p> <p><u>Auxiliary supply /binary input voltage</u> 24/30/48 V DC auxiliary, 30 V binary input 110/220 V DC auxiliary, 30 V binary input 24/30/48 V DC auxiliary, 48 V binary input 110/220 V DC auxiliary, 48 V binary input <sup>1)</sup> 110/220 V DC auxiliary, 110 V low burden binary input 110/220 V DC auxiliary, 220 V low burden binary input</p> <p><u>Type of elements</u> Single pole phase-fault or single pole earth-fault Single pole sensitive/restricted earth-fault (SEF/REF)</p> <p><u>Nominal current</u> 1/ 5 A</p> <p><u>I/O range</u> 1 Binary Inputs / 7 Binary Outputs (incl. 3 changeover)</p> <p><u>Communication interface</u> Fibre optic (ST-connector) / IEC 60870-5-103 or Modbus RTU RS485 interface / IEC 60870-5-103 or Modbus RTU</p> <p><u>Housing size</u> Case size E4 (4U high)</p>	<p>7 S G 1 1 1 <input type="checkbox"/></p> <p style="text-align: right;">0 <input type="checkbox"/> A 0</p> <p style="text-align: right;">1    A    0    1    2</p> <p style="text-align: right;">B    C</p>

<sup>1)</sup> High burden 110V & 220V binary inputs compliant with ESI48-4 ESI 1 available via external dropper resistors with 48V binary input version for 1 binary input and 110 V application, order resistor box VCE:2512H10066 in addition  
for 1 binary input and 220 V application, order resistor box VCE:2512H10068 in addition  
Refer to website for application note about ESI48-4 compliance.

## Ordering Information – 7SG113 Argus 1

Product description	Variants	Order No.
Nondirectional O/C relay Over current and earth fault protection for radial feeders, capacitor banks and industrial and commercial plant.	<p><u>Number of elements</u> Three pole relay</p> <p><u>Auxiliary supply /binary input voltage</u>            24/30/48 V DC auxiliary, 30 V binary input            110/220 V DC auxiliary, 30 V binary input            24/30/48 V DC auxiliary, 48 V binary input            110/220 V DC auxiliary, 48 V binary input <sup>1)</sup>            110/220 V DC auxiliary, 110 V low burden binary input            110/220 V DC auxiliary, 220 V low burden binary input</p> <p><u>Type of elements</u>            3 pole phase-fault or            2 pole phase-fault and earth-fault            2 pole phase-fault and sensitive/restricted earth-fault (SEF/REF)</p> <p><u>Nominal current</u> 1/ 5 A</p> <p><u>I/O range</u>            1 Binary Input / 7 Binary Outputs (incl. 3 changeover)            5 Binary Inputs / 11 Binary Outputs (incl. 3 changeover)            9 Binary Inputs / 7 Binary Outputs (incl. 3 changeover)</p> <p><u>Communication interface</u>            Fibre optic (ST-connector) / IEC 60870-5-103 or Modbus RTU            RS485 interface / IEC 60870-5-103 or Modbus RTU</p> <p><u>Housing size</u> Case size E6 (4U high)</p>	<p>7 S G 1 1 1 □ □ □ □ □ □ 0 □ A 0</p>

<sup>1)</sup> High burden 110V & 220V binary inputs compliant with ESI48-4 ESI 1 available via external dropper resistors with 48V binary input version  
for 1 binary input and 110 V application, order resistor box VCE:2512H10066 in addition  
for 5 binary inputs and 110 V application, order resistor box VCE:2512H10065 in addition  
for 9 binary inputs and 110 V application, order resistor box VCE:2512H10064 in addition  
for 1 binary input and 220 V application, order resistor box VCE:2512H10068 in addition  
for 5 binary inputs and 220 V application, order resistor box VCE:2512H10067 in addition  
for 9 binary inputs and 220 V application, order two resistor boxes VCE:2512H10067 in addition  
Refer to website for application note about ESI48-4 compliance.

## Ordering Information – 7SG114 Argus 1

Product description	Variants	Order No.
<p>Nondirectional O/C relay</p> <p>Over current and earth fault protection for radial feeders, capacitor banks and industrial and commercial plant.</p>	<p><b>Number of elements</b> Four pole relay</p> <p><b>Auxiliary supply /binary input voltage</b>                      24/30/48 V DC auxiliary, 30 V binary input                      110/220 V DC auxiliary, 30 V binary input                      24/30/48 V DC auxiliary, 48 V binary input                      110/220 V DC auxiliary, 48 V binary input <sup>1)</sup>                      110/220 V DC auxiliary, 110 V low burden binary input                      110/220 V DC auxiliary, 220 V low burden binary input</p> <p><b>Type of elements</b>                      3 pole phase-fault and earth-fault                      3 pole phase-fault and sensitive/restricted earth-fault (SEF/REF) or                      2 pole phase-fault and earth fault and sensitive/restricted earth-fault (SEF/REF)</p> <p><b>Nominal current</b> 1/ 5 A</p> <p><b>I/O range</b>                      1 Binary Input / 7 Binary Outputs (incl. 3 changeover)                      5 Binary Inputs / 11 Binary Outputs (incl. 3 changeover)                      9 Binary Inputs / 7 Binary Outputs (incl. 3 changeover)</p> <p><b>Communication interface</b>                      Fibre optic (ST-connector) / IEC 60870-5-103 or Modbus RTU                      RS485 interface / IEC 60870-5-103 or Modbus RTU</p> <p><b>Housing size</b> Case size E6 (4U high)</p>	<p>7 S G 1 1 1 □ □ □ □ 0 □ A 0</p> <p style="text-align: right;">↑ ↑ ↑ ↑ ↑ ↑ ↑ ↑ ↑ ↑ ↑ ↑ ↑</p> <p style="text-align: right;">4 0 1 2 3 4 5</p> <p style="text-align: right;">E F A 1 2 D</p>

<sup>1)</sup> High burden 110V & 220V binary inputs compliant with ESI48-4 ESI 1 available via external dropper resistors with 48V binary input version  
 for 1 binary input and 110 V application, order resistor box VCE:2512H10066 in addition  
 for 5 binary inputs and 110 V application, order resistor box VCE:2512H10065 in addition  
 for 9 binary inputs and 110 V application, order resistor box VCE:2512H10064 in addition  
 for 1 binary input and 220 V application, order resistor box VCE:2512H10068 in addition  
 for 5 binary inputs and 220 V application, order resistor box VCE:2512H10067 in addition  
 for 9 binary inputs and 220 V application, order two resistor boxes VCE:2512H10067 in addition  
 Refer to website for application note about ESI48-4 compliance

# Ordering Information – 7SG115 Argus 1

Product description	Variants	Order No.
<p>Nondirectional O/C relay</p> <p>Over current and earth fault protection for radial feeders, capacitor banks and industrial and commercial plant.</p>	<p><u>Number of elements</u> Four pole relay (fixed I/O)</p> <p><u>Auxiliary supply /binary input voltage</u> 24/30/48 V DC auxiliary, 30 V binary input 110/220 V DC auxiliary, 30 V binary input 24/30/48 V DC auxiliary, 48 V binary input 110/220 V DC auxiliary, 48 V binary input <sup>1)</sup> 110/220 V DC auxiliary, 110 V low burden binary input 110/220 V DC auxiliary, 220 V low burden binary input</p> <p><u>Type of elements</u> 3 pole phase-fault and earth-fault</p> <p><u>Nominal current</u> 1A 5A</p> <p><u>I/O range</u> 3 Binary Input / 5 Binary Outputs (incl. 2 changeover)</p> <p><u>Communication interface</u> Fibre optic (ST-connector) / IEC 60870-5-103 or Modbus RTU RS485 interface / IEC 60870-5-103 or Modbus RTU</p> <p><u>Housing size</u> Case size E4 (4U high)</p>	<p>7 S G 1 1 1 □ □ □ □ □ 0 □ A 0</p> <p style="text-align: right;">↑    ↑    ↑    ↑    ↑    ↑    ↑</p> <p style="text-align: right;">5    0    1    2    3    4    5</p> <p style="text-align: right;">E    B    C</p> <p style="text-align: right;">3    1    2</p> <p style="text-align: right;">C</p>

<sup>1)</sup> High burden 110V & 220V binary inputs compliant with ESI48-4 ESI 1 available via external dropper resistors with 48V binary input version for 5 binary inputs and 110 V application, order resistor box VCE:2512H10065 in addition for 5 binary inputs and 220 V application, order resistor box VCE:2512H10067 in addition  
Refer to website for application note about ESI48-4 compliance



## Section 2: Settings

Relay Type \_\_\_\_\_

Serial Number \_\_\_\_\_

Substation \_\_\_\_\_

Feeder Identity \_\_\_\_\_

### Notes on Tables

All settings found in the Argus 1 relay types are listed below. Within the list some settings (indicated with greyed cells) are not always visible, for the following reasons:

- Depending on the version of the relay, a particular function and hence its related settings may not be present, e.g. on a 2 phase-fault and SEF relay any settings related to earth-fault will not be present.
- Depending on the value of some settings, other settings will be hidden, e.g. if the main characteristic is set to DTL, rather than an IDMT characteristic, the time multiplier setting will be hidden and replaced by a time delay setting.

Some settings in the tables show text in square brackets, e.g. '[SEF/REF] Current Setting'. This indicates different text that may be displayed, depending on the value of other settings, i.e. 'SEF Current Setting' or 'REF Current Setting' dependent on the value of the 'Earth Fault Mode Select' setting.

The second column in the tables ('Ref') provides a reference to the section in the Technical Reference (publication P20007 issue 2004/02) that describes the setting.

The third column is left blank to allow users to complete the table with applied settings.

### System Config. Menu

Setting name	Ref	Applied value
Active Settings Group	2.2.1	
Settings Group Edit/View	2.2.1	
Copy Group	2.2.1	
Power System Frequency	2.2.2	Hz
Set Pole B Type	2.2.3	
Earth Fault Mode Select	2.2.3	
P/F Rating (In)	2.2.3	A
E/F Rating (In)	2.2.3	A
[SEF/REF] Rating (In)	2.2.3	A
P/F CT Ratio	2.2.3	
E/F CT Ratio	2.2.3	
[SEF/REF] CT Ratio	2.2.3	
Current Display	2.2.3	
Set Identifier	2.2.4	
Set Alarm 1	2.2.5	
Set Alarm 2	2.2.5	
Set Alarm 3	2.2.5	

Setting name	Ref	Applied value
Set Alarm 4	2.2.5	
Set Alarm 5	2.2.5	
Calendar – Set Date	2.2.7	
Clock - Set Time	2.2.7	
Clock Sync. From Status	2.2.7	
Default Screen Timer	2.2.8	
Change Password	2.2.9	

### Protection Menu

Setting name	Ref	Applied value
Gn P/F Charact. Setting	2.3.1	xIn
Gn P/F Charact.	2.3.1	
Gn P/F Charact. Time Mult	2.3.1	
Gn P/F Charact. Delay	2.3.1	sec
Gn P/F Lowset Setting	2.3.2	xIn
Gn P/F Lowset Delay	2.3.2	sec
Gn P/F Highset1 Setting	2.3.2	xIn
Gn P/F Highset1 Delay	2.3.2	sec

Setting name	Ref	Applied value
Gn P/F Highset2 Setting	2.3.2	xIn
Gn P/F Highset2 Delay	2.3.2	sec
Gn E/F Charact. Setting	2.3.1	xIn
Gn E/F Charact.	2.3.1	
Gn E/F Charact. Time Mult	2.3.1	
Gn E/F Charact. Delay	2.3.1	sec
Gn E/F Lowset Setting	2.3.2	xIn
Gn E/F Lowset Delay	2.3.2	sec
Gn E/F Highset1 Setting	2.3.2	xIn
Gn E/F Highset1 Delay	2.3.2	sec
Gn E/F Highset2 Setting	2.3.2	xIn
Gn E/F Highset2 Delay	2.3.2	sec
Gn [SEF/REF] Current Setting	2.4	
Gn [SEF/REF] 1st Time Delay	2.4	sec
Gn [SEF/REF] 2nd Time Delay	2.4	sec
Gn [SEF/REF] Lowset Delay	2.4	sec
Gn CB Fail Time Delay1	2.5	sec
Gn CB Fail Time Delay2	2.5	sec
Gn P/F CB Fail Setting	2.5	xIn
Gn E/F CB Fail Setting	2.5	xIn
Gn SEF CB Fail Setting	2.5	xIn
Gn CT Failure Setting	2.5.3	xIn
Gn CT Failure Delay	2.5.3	sec
Gn Relay Reset Delay	2.3.3	sec

**Output Relay Configuration Menu**

See also Figure 2-1 on page 15 for the programming matrix.

Setting name	Ref	Applied value
Gn Prot. Healthy	2.14.3	
Gn P/F Starter	2.3.1	
Gn P/F Charact.	2.3.1	
Gn P/F Lowset	2.3.2	
Gn P/F Highset1	2.3.2	
Gn P/F Highset2	2.3.2	

Setting name	Ref	Applied value
Gn E/F Starter	2.3.1	
Gn E/F Charact.	2.3.1	
Gn E/F Lowset	2.3.2	
Gn E/F Highset1	2.3.2	
Gn E/F Highset2	2.3.2	
Gn [SEF/REF] Starter	2.4	
Gn [SEF/REF] Delay1	2.4	
Gn [SEF/REF] Delay2	2.4	
Gn [SEF/REF] Lowset	2.4	
Gn Status 1	2.11	
Gn Status 2	2.11	
Gn Status 3	2.11	
Gn Status 4	2.11	
Gn Status 5	2.11	
Gn Status 6	2.11	
Gn Status 7	2.11	
Gn Status 8	2.11	
Gn Status 9	2.11	
Gn CB Fail 1	2.5	
Gn CB Fail 2	2.5	
Gn CT Failure	2.5.3	
Gn Counter Alarm	2.14.1	
Gn ΣI <sup>2</sup> Alarm	2.14.1	
Gn Power On Count	2.14.3	
Gn Hand Reset	2.11	
Min O/P Energise Time	2.11	ms

**Status Configuration Menu**

See also Figure 2-1 on page 15 for the programming matrix.

Setting name	Ref	Applied value
Settings Group Select	2.2.1	
Inverted Inputs	2.11	
Gn P/F Charact. Inhibit	2.3.1	
Gn P/F Lowset Inhibit	2.3.2	

Setting name	Ref	Applied value
Gn P/F Highset1 Inhibit	2.3.2	
Gn P/F Highset2 Inhibit	2.3.2	
Gn E/F Charact. Inhibit	2.3.1	
Gn E/F Lowset Inhibit	2.3.2	
Gn E/F HighSet 1 Inhibit	2.3.2	
Gn E/F HighSet 2 Inhibit	2.3.2	
Gn [SEF/REF] Delay1 Inhibit	2.4	
Gn [SEF/REF] Delay2 Inhibit	2.4	
Gn [SEF/REF] Lowset Inhibit	2.4	
Gn Trip Circuit Fail	2.10	
Gn Waveform Trig	2.13.3	
Gn $\Sigma I^2$ Update	2.14.1	
Gn Reset Flag & Outputs	2.11	
Gn Clock Sync.	2.2.7	
Gn Status 1 P/U Delay	2.11	sec
Gn Status 1 D/O Delay	2.11	sec
Gn Status 2 P/U Delay	2.11	sec
Gn Status 2 D/O Delay	2.11	sec
Gn Status 3 P/U Delay	2.11	sec
Gn Status 3 D/O Delay	2.11	sec
Gn Status 4 P/U Delay	2.11	sec
Gn Status 4 D/O Delay	2.11	sec
Gn Status 5 P/U Delay	2.11	sec
Gn Status 5 D/O Delay	2.11	sec
Gn Status 6 P/U Delay	2.11	sec
Gn Status 6 D/O Delay	2.11	sec
Gn Status 7 P/U Delay	2.11	sec
Gn Status 7 D/O Delay	2.11	sec
Gn Status 8 P/U Delay	2.11	sec
Gn Status 8 D/O Delay	2.11	sec
Gn Status 9 P/U Delay	2.11	sec
Gn Status 9 D/O Delay	2.11	sec
Gn Alarm 1 * see note below	2.2.5	

Setting name	Ref	Applied value
Gn Alarm 2 * see note below	2.2.5	
Gn Alarm 3 * see note below	2.2.5	
Gn Alarm 4 * see note below	2.2.5	
Gn Alarm 5 * see note below	2.2.5	

\* The text of these setting names reflects the value applied to the 'Set Alarm *n*' settings in the 'System Config.' menu.

#### Comms Interface Menu

Setting name	Ref	Applied value
Comms Protocol	4.1.1	
IEC Class 2 Measurand	4.2.6	
Class 2 Update Period	4.2.7	sec
IEC Class 2 Scaling	4.2.8	
Comms Baud Rate	4.2.9	baud
Comms Parity	4.2.10	
Relay Address	4.2.11	
Line Idle	4.2.12	
Data Echo	4.2.13	

#### Data Storage Menu

Setting name	Ref	Applied value
Gn Fault Trigger	2.13.2	
Gn Waveform Trig	2.13.3	
Gn Waveform Pre-trigger	2.13.3	%
Clear All Waveforms	2.13.3	
Clear All Events	2.13.1	
Clear All Faults	2.13.2	
Demand Window Type	2.13.4	
Demand Window	2.13.4	
Maximum Demand Reset	2.13.4	

**CB Maintenance Menu**

<u>Setting name</u>	<u>Ref</u>	<u>Applied value</u>
Trip Counter Reset	2.14.1	
Trip Counter Alarm	2.14.1	
$\Sigma I^2$ Reset	2.14.1	
$\Sigma I^2$ Alarm	2.14.1	
Power On Count Reset	2.14.3	
Power On Count Alarm	2.14.3	
O/P Relay Test	2.14.2	

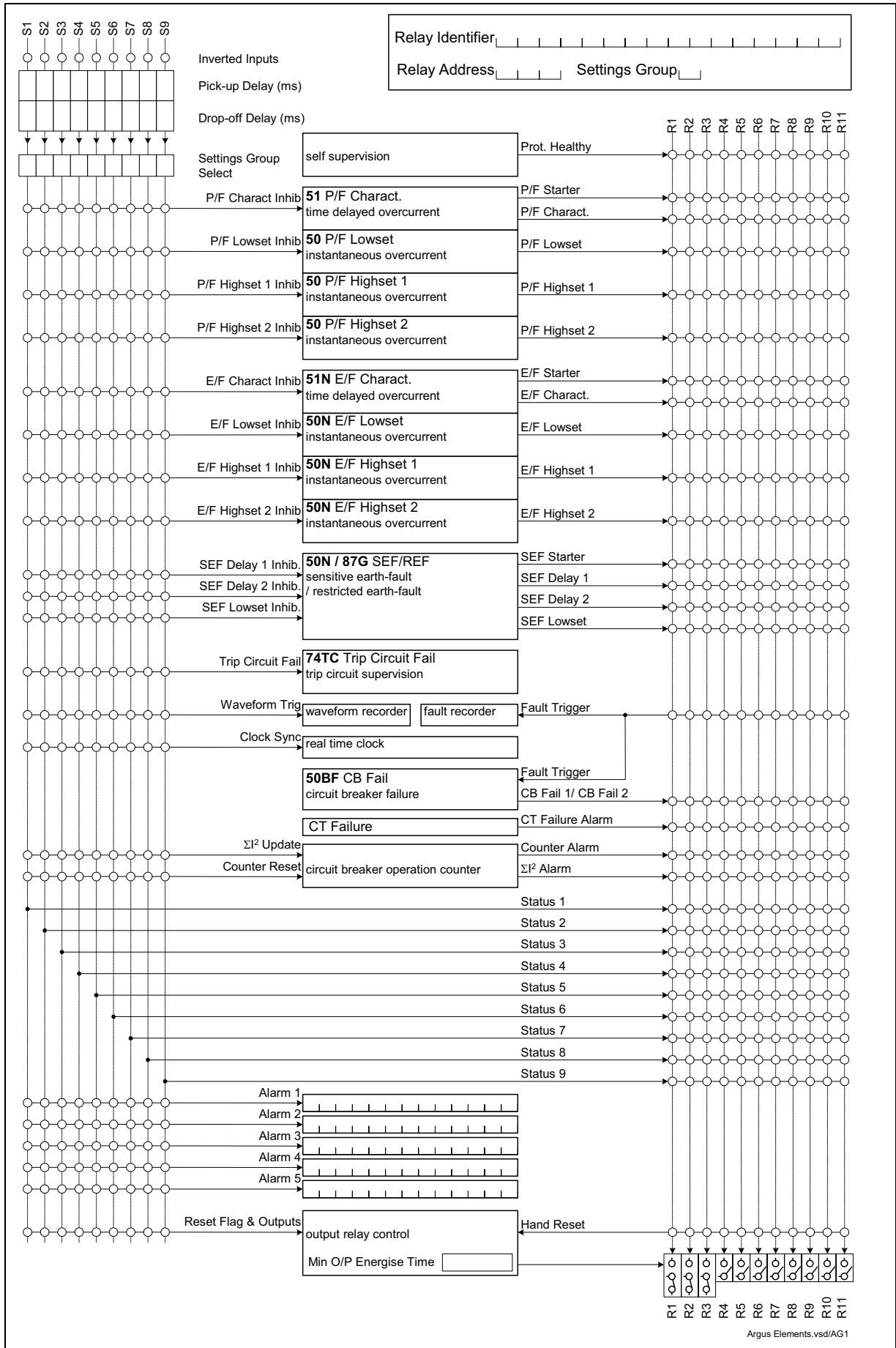


Figure 2-1 Status Input and Output Relay Programming Matrix

## Section 3: IEC 60870-5-103 & Modbus RTU Definitions

### 3.1 IEC 60870-5-103 Definitions

The following tables give information on the IEC 60870-5-103 protocol. A detailed description of all protocol information is available in report no 434/TM/5/13 which can be accessed on the [www.siemens.com/energy](http://www.siemens.com/energy) in publications section under technical reports, "communications interface manual".

**Table Showing Function Type Numbers Used**

Function Type	Description
160	IEC Overcurrent Protection
164	Reyrolle Overcurrent Protection
254	IEC Generic
255	IEC Global

#### Cause of Transmission

The cause of transmission (COT) column of the 'Information Number and Function' table lists possible causes of transmission for these frames. The following abbreviations are used:

**Table Showing Permitted Cause of Transmission Numbers**

Cause of Transmission (COT)	Description
1	Spontaneous Events
2	Cyclic
3	Reset Frame Count Bit (FCB)
4	Reset Communication Unit (CU)
5	Start Restart
6	Power On
7	Test Mode
8	Time Synchronisation
9	General Interrogation
10	Termination of General Interrogation
11	Local Operation
12	Remote Operation
20	Positive Command Acknowledge
21	Negative Command Acknowledge
31	Transmission of Disturbance Data

#### Information Number and Function

The following tables list information number and function definitions together with a description of the message and function type and cause of transmission that can result in that message. Not all definitions are available on all relay types – this is dependent on functionality.

<b>KEY</b>	<b>FUN</b>	Function Type (defined in IEC60870-5-103 section 7.2.5.1)
	<b>INF</b>	Information Number (defined in IEC60870-5-103 section 7.2.5.2)
	<b>TYP</b>	ASDU Type (defined in IEC60870-5-103 sections 7.3.1 and 7.3.2)
	<b>GI</b>	Event supports General Interrogation x = supported (defined in IEC60870-5-103 section 7.2.5.2)
	<b>COM</b>	Type of command single (ON only) or double (ON/OFF) (defined in IEC60870-5-103 section 7.2.5.2)
	<b>COT</b>	Cause of Transmission (defined in IEC60870-5-103 section 7.2.3, table 5)
	<b>DIR</b>	Direction of event - Raised Only (RO), Raised/Cleared (RC) or Double Point Travelling, Cleared, Raised or Unknown (DBI)
	<b>x</b>	Supported, - Not supported.

Table Showing Command Information (INF) Numbers

FUN	INF	Description	GI	TYP	COT	DIR	Argus 1
160	2	Reset FCB	-	5	3	RO	x
160	3	Reset CU	-	5	4	RO	x
160	4	Start/Restart	-	5	5	RO	x
160	5	Power On	-	5	6	RO	x
160	16	ARC in progress	x	1	1, 9, 12, 20, 21	RC	
160	19	LEDs reset	-	1	1, 7, 11, 12, 20, 21	RO	x
160	21	Trip Test	x	1	1, 9	RC	x
160	22	Settings changed	x	1	1, 9, 11, 12	RC	x
160	23	Setting G1 selected	x	1	1, 9, 11, 12, 20, 21	RC	x
160	24	Setting G2 selected	x	1	1, 9, 11, 12, 20, 21	RC	x
160	25	Setting G3 selected	x	1	1, 9, 11, 12, 20, 21	RC	x
160	26	Setting G4 selected	x	1	1, 9, 11, 12, 20, 21	RC	x
160	27	Input 1	x	1	1, 9	RC	x
160	28	Input 2	x	1	1, 9	RC	x
160	29	Input 3	x	1	1, 9	RC	x
160	30	Input 4	x	1	1, 9	RC	x
160	36	Trip circuit fail	x	1	1, 9	RC	x
160	46	Group Warning	x	1	1, 9	RC	
160	47	Alarm	x	1	1, 9	RO	
160	64	A-starter	x	2	1, 9	RC	x
160	65	B-starter	x	2	1, 9	RC	x
160	66	C-starter	x	2	1, 9	RC	x
160	67	E-starter	x	2	1, 9	RC	x
160	68	General trip	-	2	1	RO	x
160	69	A-general trip	-	2	1	RO	x
160	70	B-general trip	-	2	1	RO	x
160	71	C-general trip	-	2	1	RO	x
160	84	General starter	x	2	1, 9	RC	x
160	85	Circuit breaker fail 1	-	2	1	RO	x
160	91	P/F-general HS trip	-	2	1	RO	x
160	92	E/F-general trip	-	2	1	RO	x

FUN	INF	Description	GI	TYP	COT	DIR	Argus 1
160	93	E/F-general HS trip	-	2	1	RO	x
160	128	CB on by auto reclose	-	1	1	DP	
160	130	Reclose blocked	x	1	1, 9	RC	
160	144	Measurand I <sup>1</sup>	-	3.1	2,7	-	x
160	148	Measurand I <sub>L1,2,3</sub> , V <sub>L1,2,3</sub> , P, Q	-	9	2,7	-	x
164	0	Data lost	-	1	1	RO	x
164	1	A-lowset starter	-	2	1	RC	x
164	2	B-lowset starter	-	2	1	RC	x
164	3	C-lowset starter	-	2	1	RC	x
164	4	E-lowset starter	-	2	1	RC	x
164	5	A-lowset trip	-	2	1	RO	x
164	6	B-lowset trip	-	2	1	RO	x
164	7	C-lowset trip	-	2	1	RO	x
164	8	E-lowset trip	-	2	1	RO	x
164	9	A-delayed trip	-	2	1	RO	x
164	10	B-delayed trip	-	2	1	RO	x
164	11	C-delayed trip	-	2	1	RO	x
164	12	E-delayed trip	-	2	1	RO	x
164	13	A-HS1 trip	-	2	1	RO	x
164	14	B-HS1 trip	-	2	1	RO	x
164	15	C-HS1 trip	-	2	1	RO	x
164	16	E-HS1 trip	-	2	1	RO	x
164	17	A-HS2 trip	-	2	1	RO	x
164	18	B-HS2 trip	-	2	1	RO	x
164	19	C-HS2 trip	-	2	1	RO	x
164	20	E-HS2 trip	-	2	1	RO	x
164	21	SEF/REF starter	x	2	1, 9	RC	x
164	23	SEF/REF lowset trip	-	2	1	RC	x
164	24	SEF/REF stage 1 trip	-	2	1	RC	x
164	25	SEF/REF stage 2 trip	-	2	1	RC	x
164	26	A-HS1 starter	-	2	1	RC	x
164	27	B-HS1 starter	-	2	1	RC	x
164	28	C-HS1 starter	-	2	1	RC	x

<sup>1</sup> One of Ia, Ib, Ic, Id depending on relay type



FUN	INF	Description	GI	TYP	COT	DIR	Argus 1
164	29	E-HS1 starter	-	2	1	RC	x
164	30	A-HS2 starter	-	2	1	RC	x
164	31	B-HS2 starter	-	2	1	RC	x
164	32	C-HS2 starter	-	2	1	RC	x
164	33	E-HS2 starter	-	2	1	RC	x
164	34	Circuit breaker open	x	1	1, 9	RO	
164	35	Setting G5 selected	x	1	1, 9, 11, 12, 20, 21	RC	x
164	36	Setting G6 selected	x	1	1, 9, 11, 12, 20, 21	RC	x
164	37	Setting G7 selected	x	1	1, 9, 11, 12, 20, 21	RC	x
164	38	Setting G8 selected	x	1	1, 9, 11, 12, 20, 21	RC	x
164	39	Circuit breaker fail 2	-	2	1	RO	x
164	41	CB close fail	x	1	1, 9	RO	
164	43	CB DBI state	x	1	1, 9	RO	
164	44	External Trip	-	2	1	RO	x
164	45	Input 5	x	1	1, 9	RC	x
164	46	Input 6	x	1	1, 9	RC	x
164	47	Input 7	x	1	1, 9	RC	x
164	48	Input 8	x	1	1, 9	RC	x
164	49	Input 9	x	1	1, 9	RC	x
164	51	Output 1	x	1	1, 9, 12, 20, 21	RC	x
164	52	Output 2	x	1	1, 9, 12, 20, 21	RC	x
164	53	Output 3	x	1	1, 9, 12, 20, 21	RC	x
164	54	Output 4	x	1	1, 9, 12, 20, 21	RC	x
164	55	Output 5	x	1	1, 9, 12, 20, 21	RC	x
164	56	Output 6	x	1	1, 9, 12, 20, 21	RC	x
164	57	Output 7	x	1	1, 9, 12, 20, 21	RC	x
164	58	Output 8	x	1	1, 9, 12, 20, 21	RC	x
164	59	Output 9	x	1	1, 9, 12, 20, 21	RC	x
164	60	Output 10	x	1	1, 9, 12, 20, 21	RC	x
164	61	Output 11	x	1	1, 9, 12, 20, 21	RC	x
164	62	Forward A	x	2	1, 9	RC	
164	63	Reverse A	x	2	1, 9	RC	
164	64	Forward B	x	2	1, 9	RC	
164	65	Reverse B	x	2	1, 9	RC	
164	66	Forward C	x	2	1, 9	RC	
164	67	Reverse C	x	2	1, 9	RC	
164	68	Forward E	x	2	1, 9	RC	
164	69	Reverse E	x	2	1, 9	RC	

FUN	INF	Description	GI	TYP	COT	DIR	Argus 1
164	70	Trip count alarm	x	1	1, 9	RC	x
164	70	Trip count alarm	x	4	1, 9	-	x
164	71	CB maintenance alarm	x	1	1, 9	RC	x
164	71	CB maintenance alarm	x	4	1, 9	-	x
164	72	Frequent operations exceeded	x	1	1, 9	RC	
164	73	Delta Trip Counter Alarm	x	1	1, 9	RC	
164	79	Voltage Block	x	1	1, 9	RC	
164	80	Waveform stored	-	1	1, 12, 20, 21	RO	x
164	81	Remote control interrupted	-	1	1	RO	x
164	82	Trip and Lockout	-	1	1, 12, 20, 21	RO	
164	83	Close and Reclaim	-	1	1, 12, 20, 21	RO	
164	84	Trip And Reclose	-	1	1, 12, 20, 21	RO	
164	85	Circuit breaker closed	x	1	1, 9	RO	
164	86	Close And Lockin	-	1	1, 12, 20, 21	RO	
164	87	Reclose delay	x	1	1, 9	RC	
164	88	Reclaim	x	1	1, 9	RC	
164	89	Lockout	x	1	1, 9	RC	
164	90	Forward SEF	x	2	1, 9	RC	
164	91	Reverse SEF	x	2	1, 9	RC	
164	92	Power On Counter Alarm	x	1	1, 9	RC	x
164	97	CT Failure	x	1	1, 9	RC	x
164	100	Cold load pickup	x	1	1, 9, 12, 20, 21	RC	
164	101	Cold load trip	-	2	1	RO	
164	102	Line check trip	-	2	1	RO	
164	103	ARC start A	x	1	1, 9	RC	
164	104	A backup time	-	1	1	RC	
164	105	A backup trip	-	1	1	RC	
164	106	External trip block	x	1	1, 9	RC	
164	110	SEF off	x	1	1, 9, 12, 20, 21	RC	
164	111	All ARC off	x	1	1, 9	RC	
164	112	P/F ARC off	x	1	1, 9, 12, 20, 21	RC	
164	113	E/F ARC off	x	1	1, 9, 12, 20, 21	RC	
164	114	SEF ARC off	x	1	1, 9, 12, 20, 21	RC	
164	115	All inst off	x	1	1, 9, 12, 20, 21	RC	
164	116	P/F inst off	x	1	1, 9, 12, 20, 21	RC	
164	117	E/F inst off	x	1	1, 9, 12, 20, 21	RC	

FUN	INF	Description	GI	TYP	COT	DIR	Argus 1
164	118	SEF inst off	x	1	1, 9, 12, 20, 21	RC	
164	119	Hot line working	x	1	1, 9, 12, 20, 21	RC	
164	120	Scada Control	x	1	1, 9	RC	
164	121	General alarm 1	x	1	1, 9	RC	x
164	122	General alarm 2	x	1	1, 9	RC	x
164	123	General alarm 3	x	1	1, 9	RC	x
164	124	General alarm 4	x	1	1, 9	RC	x
164	125	General alarm 5	x	1	1, 9	RC	x
164	131	Va/Vab starter	x	2	1, 9	RC	
164	132	Vb/Vbc starter	x	2	1, 9	RC	
164	133	Vc/Vca starter	x	2	1, 9	RC	
164	170	V starter	x	2	1, 9	RC	
164	182	V trip	-	2	1	RO	
164	190	Voltage Memory A	x	1	1, 9	RC	
164	191	Voltage Memory B	x	1	1, 9	RC	
164	192	Voltage Memory C	x	1	1, 9	RC	
164	240	Ia Fault Current	x	4	1, 9	-	x
164	241	Ib Fault Current	x	4	1, 9	-	x
164	242	Ic Fault Current	x	4	1, 9	-	x
164	243	Ie Fault Current	x	4	1, 9	-	x
164	244	Isef Fault Current	x	4	1, 9	-	x
164	245	Va Fault Voltage	x	4	1, 9	-	
164	246	Vb Fault Voltage	x	4	1, 9	-	
164	247	Vc Fault Voltage	x	4	1, 9	-	
164	248	Vn Fault Voltage	x	4	1, 9	-	
255	0	Time Synchronisation	-	6	8	-	x
255	0	End of General Interrogation	-	8	10	-	x

Table Showing Command Information (INF) Numbers

FUN	INF	Description	COM	TYP	COT	Argus 1
160	16	Auto-recloser ON/OFF	ON/OFF	20	20	
160	19	Reset Flag & Outputs	ON	20	20	x

FUN	INF	Description	COM	TYP	COT		Argus 1
160	23	Settings Group 1 Select	ON	20	20		x
160	24	Settings Group 2 Select	ON	20	20		x
160	25	Settings Group 3 Select	ON	20	20		x
160	26	Settings Group 4 Select	ON	20	20		x
164	35	Settings Group 5 Select	ON	20	20		x
164	36	Settings Group 6 Select	ON	20	20		x
164	37	Settings Group 7 Select	ON	20	20		x
164	38	Settings Group 8 Select	ON	20	20		x
164	51	Energise Output 1	ON	20	20		x
164	52	Energise Output 2	ON	20	20		x
164	53	Energise Output 3	ON	20	20		x
164	54	Energise Output 4	ON	20	20		x
164	55	Energise Output 5	ON	20	20		x
164	56	Energise Output 6	ON	20	20		x
164	57	Energise Output 7	ON	20	20		x
164	58	Energise Output 8	ON	20	20		x
164	59	Energise Output 9	ON	20	20		x
164	60	Energise Output 10	ON	20	20		x
164	61	Energise Output 11	ON	20	20		x
164	80	Trigger Waveform Storage	ON	20	20		x
164	82	Trip and Lockout	ON	20	20		
164	83	Close and Reclaim	ON	20	20		
164	84	Trip And Reclose	ON	20	20		
164	86	Close And Lockin	ON/OFF	20	20		
164	100	Cold load pickup	ON/OFF	20	20		
164	110	SEF	ON/OFF	20	20		
164	112	P/F ARC Inhibit	ON/OFF	20	20		
164	113	E/F ARC Inhibit	ON/OFF	20	20		
164	114	SEF ARC Inhibit	ON/OFF	20	20		
164	115	Instantaneous	ON/OFF	20	20		
164	116	P/F Instantaneous	ON/OFF	20	20		
164	117	E/F Instantaneous	ON/OFF	20	20		
164	118	SEF Instantaneous	ON/OFF	20	20		

FUN	INF	Description	COM	TYP	COT		Argus 1
164	119	Hot line working	ON/OFF	20	20		
164	129	Reset Energy Meters	ON/OFF	20	20		
164	130	Reset Maximum Demand	ON/OFF	20	20		x
255	0	Initiate General Interrogation	-	7	9	-	x
255	0	Time Synchronisation	-	6	8		x

Note: Events listing a GI cause of transmission can be raised and cleared; other events are raised only.

## 3.2 Modbus RTU Definitions

The following tables give information for MODBUS RTU access to IEC 60870-5-103 protocol data. A detailed description of all protocol information is available in report no 434/TM/5/13 which can be accessed on the [www.reyrolle-protection.com](http://www.reyrolle-protection.com) in publications section under technical reports, "communications interface manual".

The tables below detail the MODBUS address map, listing data points that are available and the functions supported for access. **Please note, not all addresses will apply to all models.**

To configure MODBUS a new setting has been added to the communications sub-menu to select the protocol to use, either IEC60870-5-103 or MODBUS-RTU. After selecting MODBUS, set the remaining parameters, baud rate, parity, station (slave) address, line idle and data echo as appropriate.

When an electrical RS485 module is connected to the Argus relay, the **Line Idle** and **Data Echo** settings must both be set to **OFF**.

**Table showing Coil Addresses**

MODBUS Address	IEC FUN	IEC INF	Description	COM	AG 1
00016	160	16	Autoreclose	ON/OFF	
00019	160	19	Reset Flag & Outputs *	ON	x
00023	160	23	Settings Group 1 Select	ON	x
00024	160	24	Settings Group 2 Select	ON	x
00025	160	25	Settings Group 3 Select	ON	x
00026	160	26	Settings Group 4 Select	ON	x
01059	164	35	Settings Group 5 Select	ON	x
01060	164	36	Settings Group 6 Select	ON	x
01061	164	37	Settings Group 7 Select	ON	x
01062	164	38	Settings Group 8 Select	ON	x
01075	164	51	Energise Output 1	ON	x
01076	164	52	Energise Output 2	ON	x
01077	164	53	Energise Output 3	ON	x
01078	164	54	Energise Output 4	ON	x

<b>MODBUS Address</b>	<b>IEC FUN</b>	<b>IEC INF</b>	<b>Description</b>	<b>COM</b>	<b>AG 1</b>
01079	164	55	Energise Output 5	ON	x
01080	164	56	Energise Output 6	ON	x
01081	164	57	Energise Output 7	ON	x
01082	164	58	Energise Output 8	ON	x
01083	164	59	Energise Output 9	ON	x
01084	164	60	Energise Output 10	ON	x
01085	164	61	Energise Output 11	ON	x
01104	164	80	Trigger Waveform Storage *	ON	x
01106	164	82	Trip and Lockout*	ON	
01107	164	83	Close and Reclaim*	ON	
01108	164	84	Trip and Reclose*	ON	
01110	164	86	Close and Lockin*	ON/OFF	
01124	164	100	Cold Load Pickup	ON/OFF	
01134	164	110	SEF	ON/OFF	
01136	164	112	PF ARC Inhibit	ON/OFF	
01137	164	113	EF ARC Inhibit	ON/OFF	
01138	164	114	SEF ARC Inhibit	ON/OFF	
01139	164	115	Instantaneous	ON/OFF	
01140	164	116	P/F Instantaneous	ON/OFF	
01141	164	117	E/F Instantaneous	ON/OFF	
01142	164	118	SEF Instantaneous	ON/OFF	
01143	164	119	Hot Line Working	ON/OFF	
01154	164	130	Reset Maximum Demand *	ON	

Table Showing Inputs

<b>MODBUS Address</b>	<b>FUN</b>	<b>INF</b>	<b>Description</b>	<b>AG 1</b>
10016	160	16	Auto Reclose Active	
10021	160	21	Trip Test	x
10022	160	22	Settings changed	x
10023	160	23	Setting G1 selected	x
10024	160	24	Setting G2 selected	x
10025	160	25	Setting G3 selected	x
10026	160	26	Setting G4 selected	x
10027	160	27	Input 1	x
10028	160	28	Input 2	x
10029	160	29	Input 3	x
10030	160	30	Input 4	x

<b>MODBUS Address</b>	<b>FUN</b>	<b>INF</b>	<b>Description</b>	<b>AG 1</b>
10036	160	36	Trip circuit fail	x
10046	160	46	Group Warning	
10047	160	47	Alarm	
10064	160	64	A-starter	x
10065	160	65	B-starter	x
10066	160	66	C-starter	x
10067	160	67	E-starter	x
10084	160	84	General starter	x
10128	160	128	CB on by auto recluse	
10130	160	130	Reclose blocked	
11045	164	21	SEF/REF starter	x
11058	164	34	Circuit breaker open	
11059	164	35	Setting G5 selected	x
11060	164	36	Setting G6 selected	x
11061	164	37	Setting G7 selected	x
11062	164	38	Setting G8 selected	x
11065	164	41	CB close fail	
11067	164	43	CB DBI state	
11069	164	45	Input 5	x
11070	164	46	Input 6	x
11071	164	47	Input 7	x
11072	164	48	Input 8	x
11073	164	49	Input 9	x
11075	164	51	Output1	x
11076	164	52	Output2	x
11077	164	53	Output3	x
11078	164	54	Output4	x
11079	164	55	Output5	x
11080	164	56	Output6	x
11081	164	57	Output7	x
11082	164	58	Output8	x
11083	164	59	Output9	x
11084	164	60	Output10	x
11085	164	61	Output11	x
11086	164	62	Forward A	
11087	164	63	Reverse A	
11088	164	64	Forward B	
11089	164	65	Reverse B	
11090	164	66	Forward C	

<b>MODBUS Address</b>	<b>FUN</b>	<b>INF</b>	<b>Description</b>	<b>AG 1</b>
11091	164	67	Reverse C	
11092	164	68	Forward E	
11093	164	69	Reverse E	
11094	164	70	Trip count alarm	x
11095	164	71	CB maintenance alarm	x
11096	164	72	Frequent operations exceeded	
11097	164	73	Delta Trip Counter Alarm	
11103	164	79	Voltage Block	
11109	164	85	Circuit breaker closed	
11111	164	87	Reclose Delay	
11112	164	88	Reclaim	
11113	164	89	Lockout	
11114	164	90	Forward SEF	
11115	164	91	Reverse SEF	
11116	164	92	Power On Counter Alarm	x
11121	164	97	CT Failure	x
11124	164	100	Cold load pickup	
11127	164	103	ARC start A	
11130	164	106	External trip block	
11134	164	110	SEF off	
11135	164	111	All ARC off	
11136	164	112	P/F ARC off	
11137	164	113	E/F ARC off	
11138	164	114	SEF ARC off	
11139	164	115	All inst off	
11140	164	116	P/F inst off	
11141	164	117	E/F inst off	
11142	164	118	SEF inst off	
11143	164	119	Hot line working	
11144	164	120	Scada Control	
11145	164	121	General alarm 1	x
11146	164	122	General alarm 2	x
11147	164	123	General alarm 3	x
11148	164	124	General alarm 4	x
11149	164	125	General alarm 5	x
11155	164	131	Va/Vab starter	
11156	164	132	Vb/Vbc starter	
11157	164	133	Vc/Vca starter	
11194	164	170	V starter	



MODBUS Address	FUN	INF	Description	AG 1
11214	164	190	Voltage Memory A	
11215	164	191	Voltage Memory B	
11216	164	192	Voltage Memory C	

Table Showing Input Registers

MODBUS Address	Description	Size (Words)	Scaling	Units Scaled	AG 1
30001	Number Of Events In Store	1	1	-	x
30002	Latest Event Record	8	-	-	x
30101	IA (PRIMARY)	2	1000	A	x
30103	IB (PRIMARY)	2	1000	A	x
30105	IC (PRIMARY)	2	1000	A	x
30107	IE (PRIMARY)	2	1000	A	x
30109	ISEF/REF (PRIMARY)	2	1000	A	x
30111	Ia (SECONDARY)	2	1000	A	x
30113	Ib (SECONDARY)	2	1000	A	x
30115	Ic (SECONDARY)	2	1000	A	x
30117	Ie (SECONDARY)	2	1000	A	x
30119	Isef/ref (SECONDARY)	2	1000	A	x
30121	Ia (xIn)	2	1000	xIn	x
30123	Ib (xIn)	2	1000	xIn	x
30125	Ic (xIn)	2	1000	xIn	x
30127	Ie (xIn)	2	1000	xIn	x
30129	Isef/ref (xIn)	2	1000	xIn	x
30131	A Direction	8	-	-	
30139	B Direction	8	-	-	
30147	C Direction	8	-	-	
30155	E Direction	8	-	-	
30163	Relay Status	8	-	-	x
30171	Status Inputs	8	-	-	x
30179	Trip Circuit Fail	8	-	-	x
30187	Trip Counter	2	1	-	x
30189	Delta Trip Count	2	1	-	
30191	Frequent Operation Counter	2	1	-	
30193	Sum of I <sup>2</sup>	2	100	MA <sup>2</sup>	x
30195	Number of Waveforms	2	1	-	x
30197	Number of Events	2	1	-	x
30199	Number of Faults	2	1	-	x
30201	Time	8	-	-	x
30209	Date	8	-	-	x
30217	Starters	8	-	-	x
30257	General Alarms	8	-	-	x
30265	Power On/Resets	8	-	-	x
30273	ARC Status	8	-	-	
30281	ARC Inhibits	8	-	-	



## Section 4: Application Diagrams

The following pages contain example application diagrams for a variety of connections, showing various hardware options.

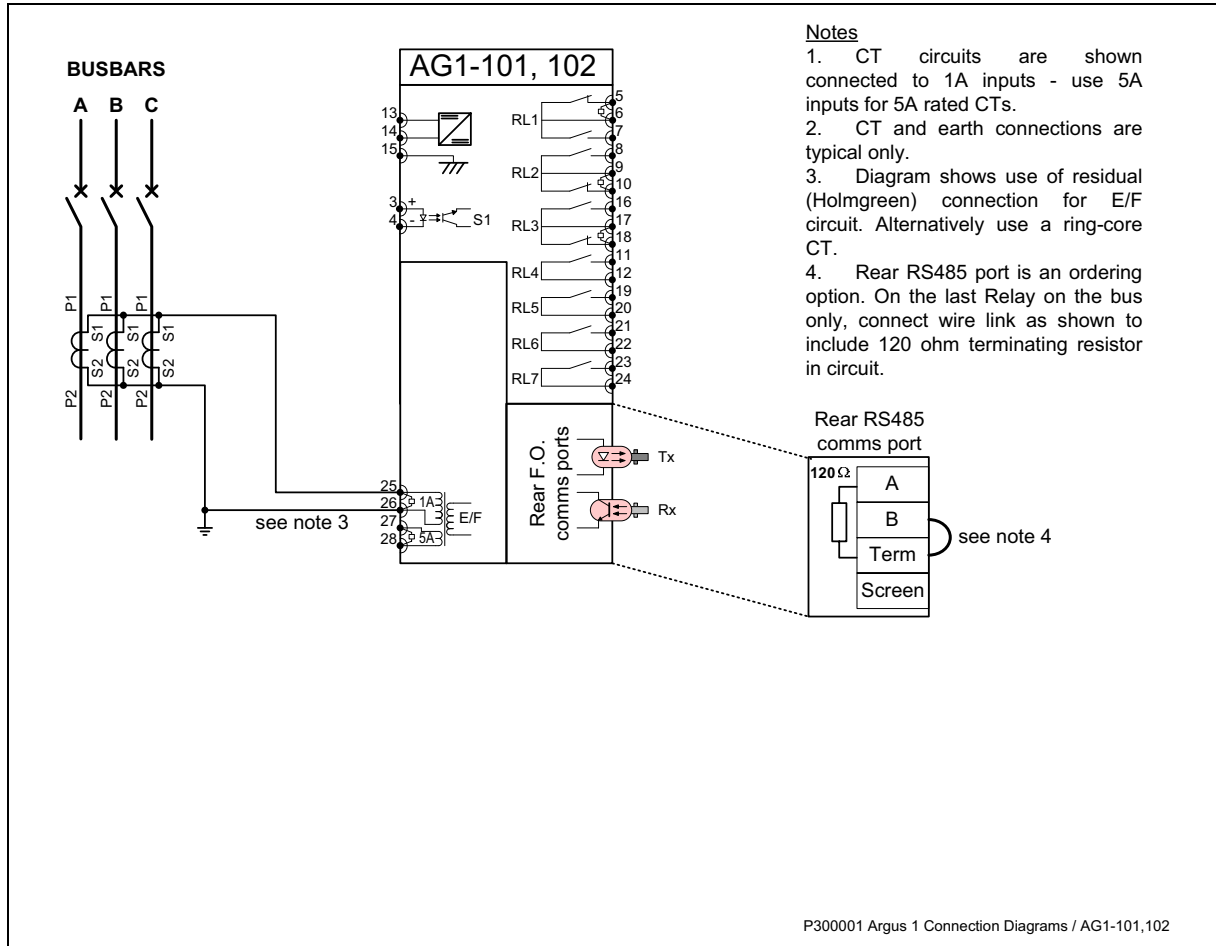


Figure 4-1 Typical Connection for Earth-fault Protection

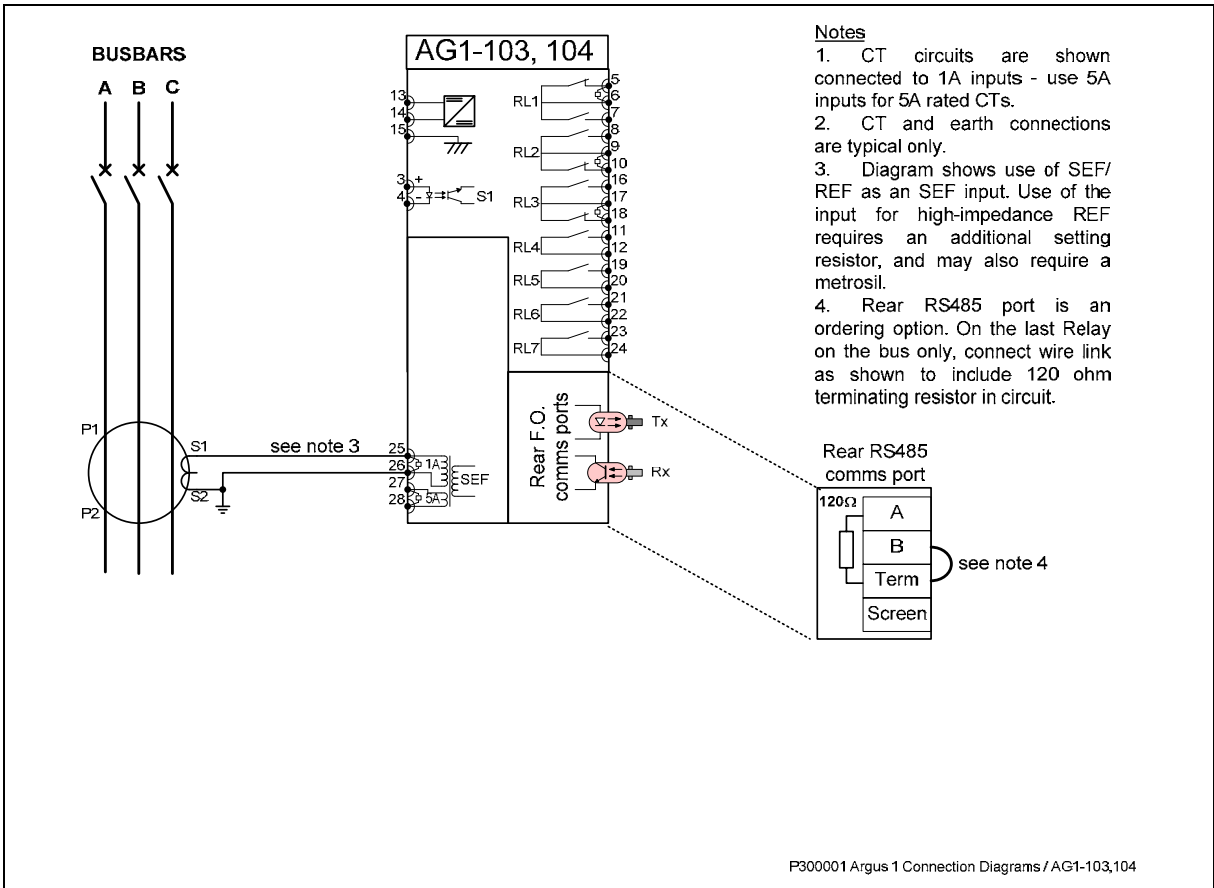


Figure 4-2 Typical Connection for Sensitive Earth-fault Protection

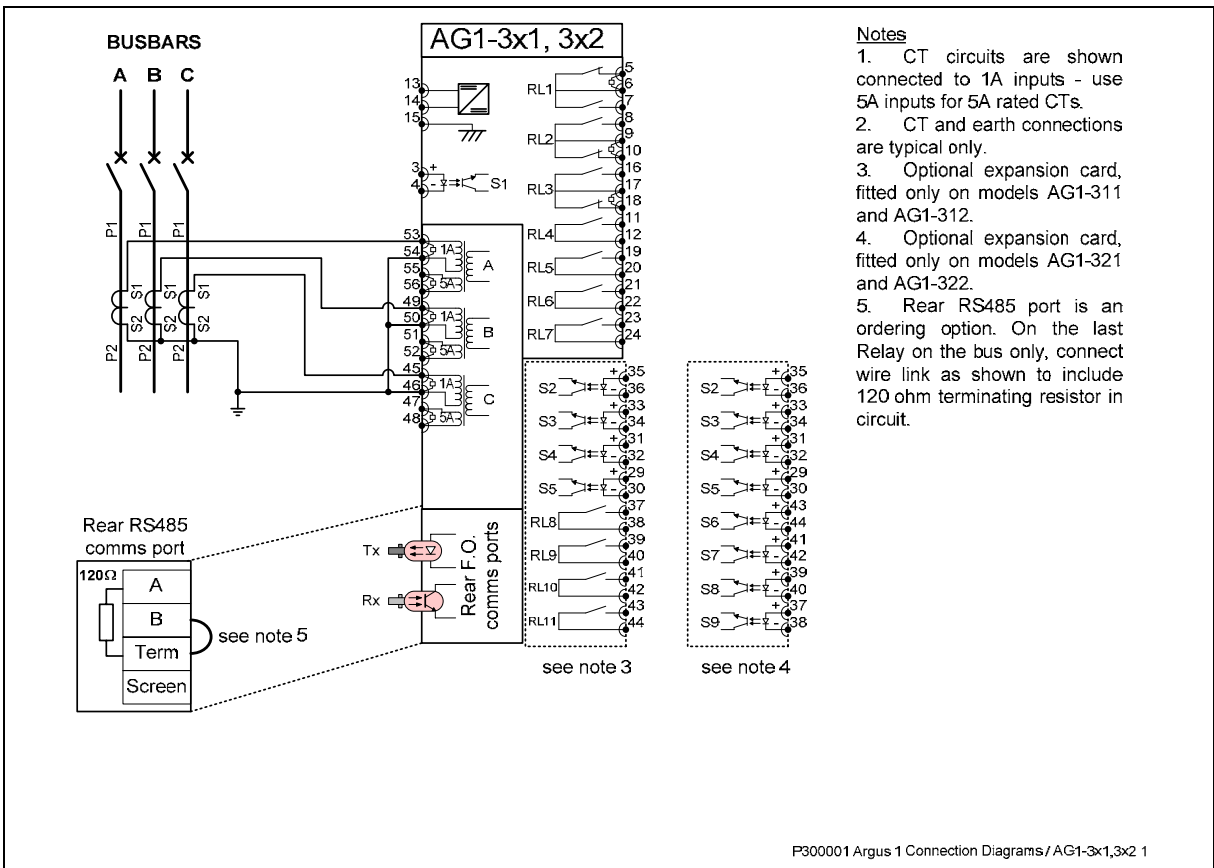


Figure 4-3 Typical Connection for 3 Phase-fault Protection

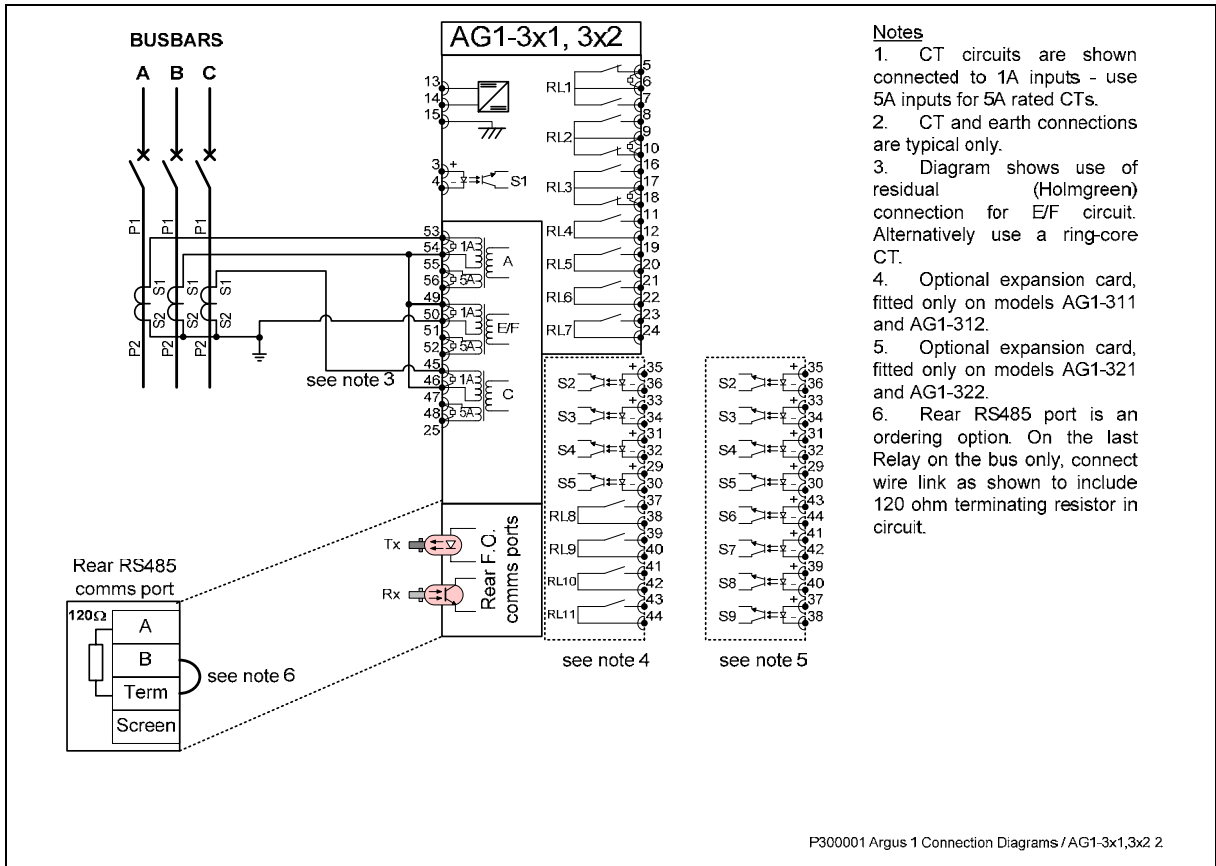


Figure 4-4 Typical Connection for 2 Phase-fault and Earth-fault Protection

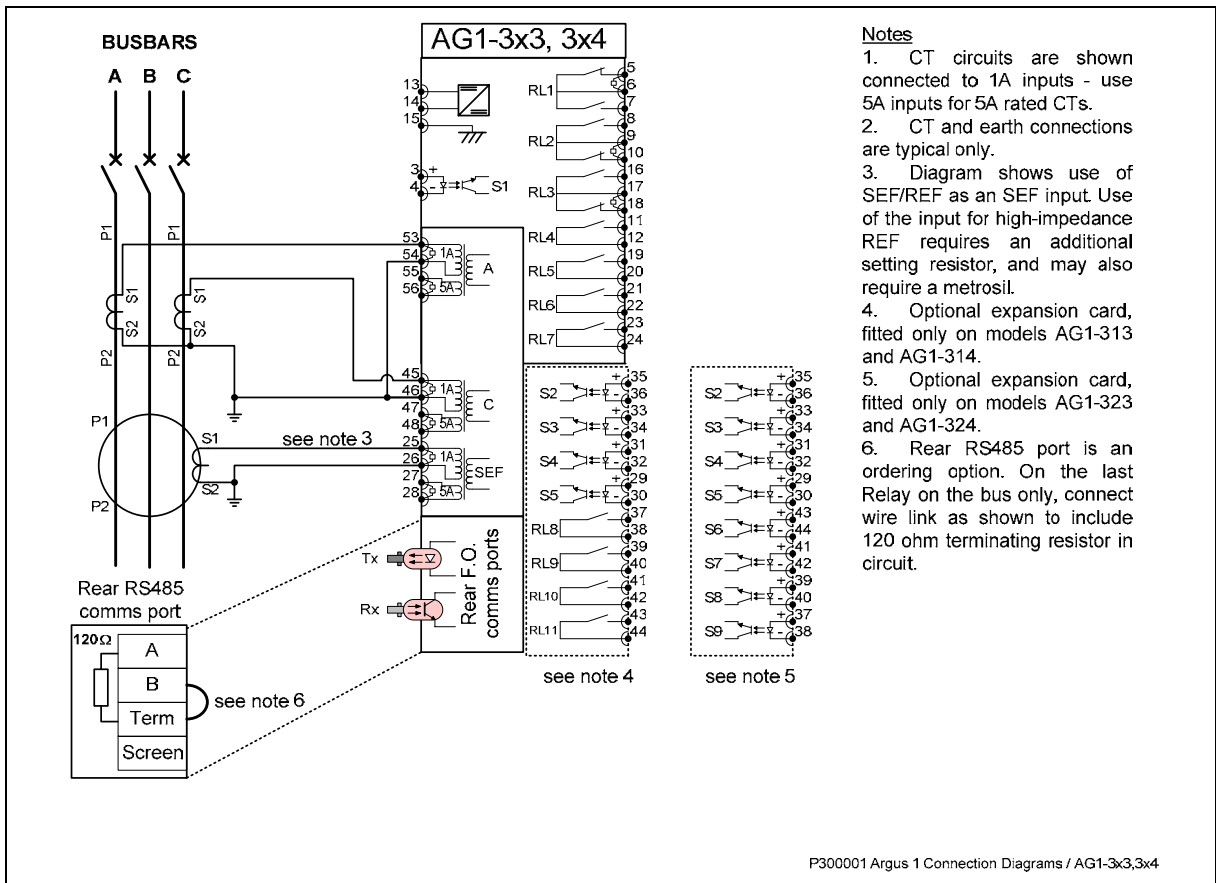


Figure 4-5 Typical Connection for 2 Phase-fault and Sensitive Earth-fault Protection

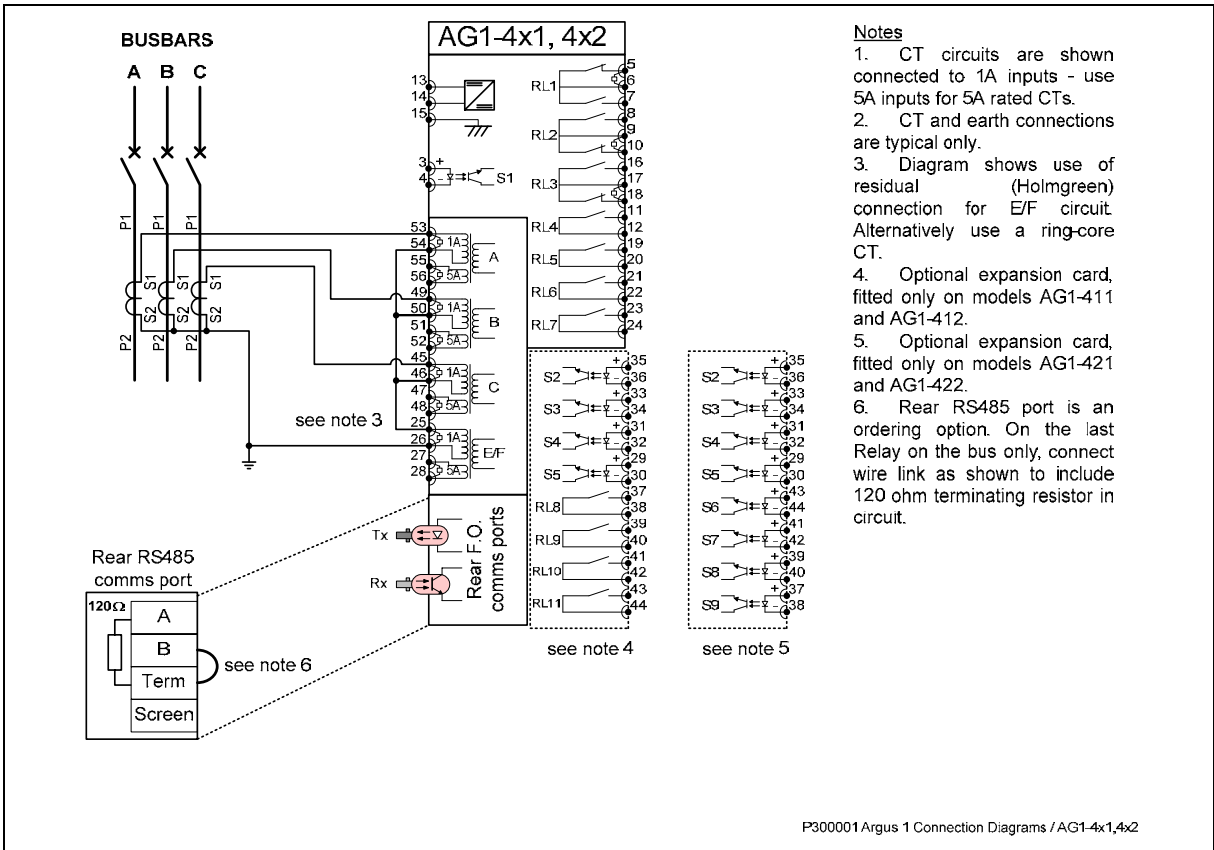


Figure 4-6 Typical Connection for 3 Phase-fault and Earth-fault Protection

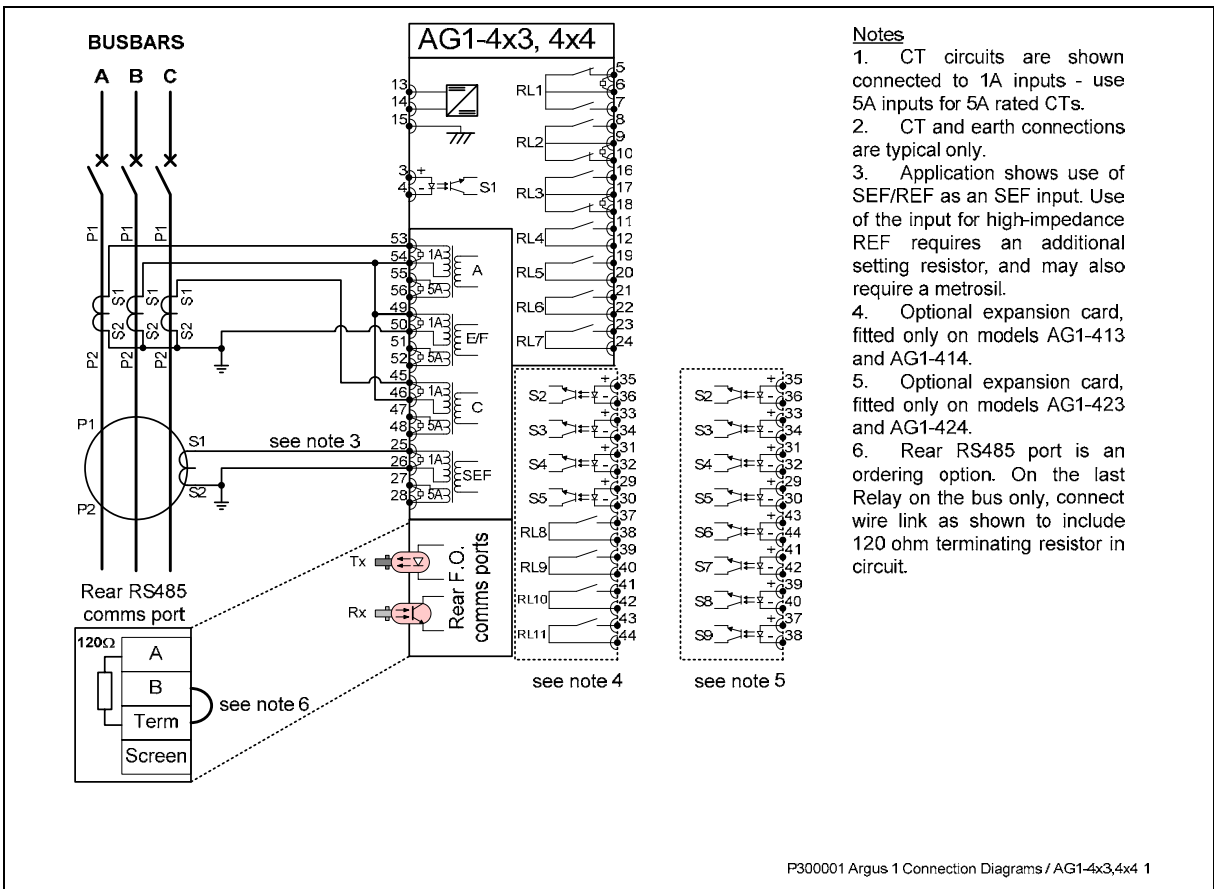


Figure 4-7 Typical Connection for 2 Phase-fault, Earth-fault and Sensitive Earth-fault Protection

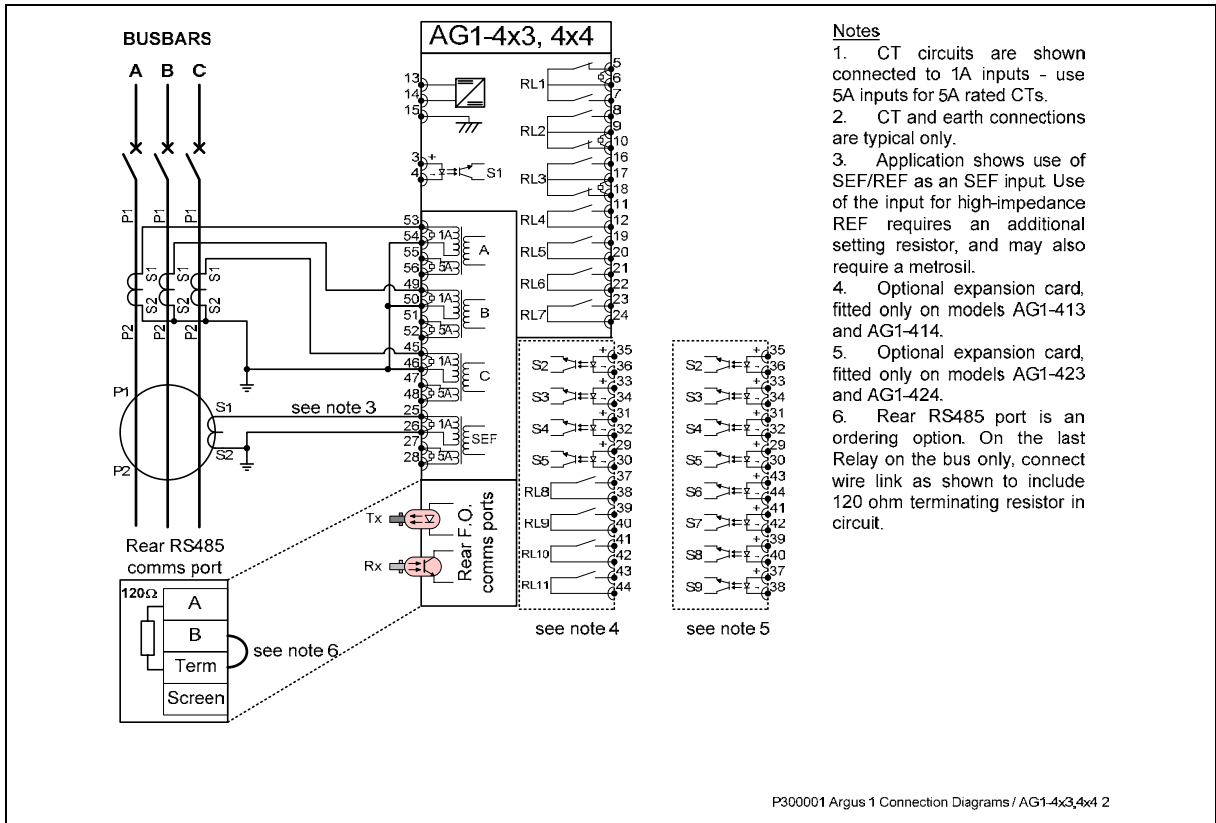


Figure 4-8 Typical Connection for 3 Phase-fault and Sensitive Earth-fault Protection

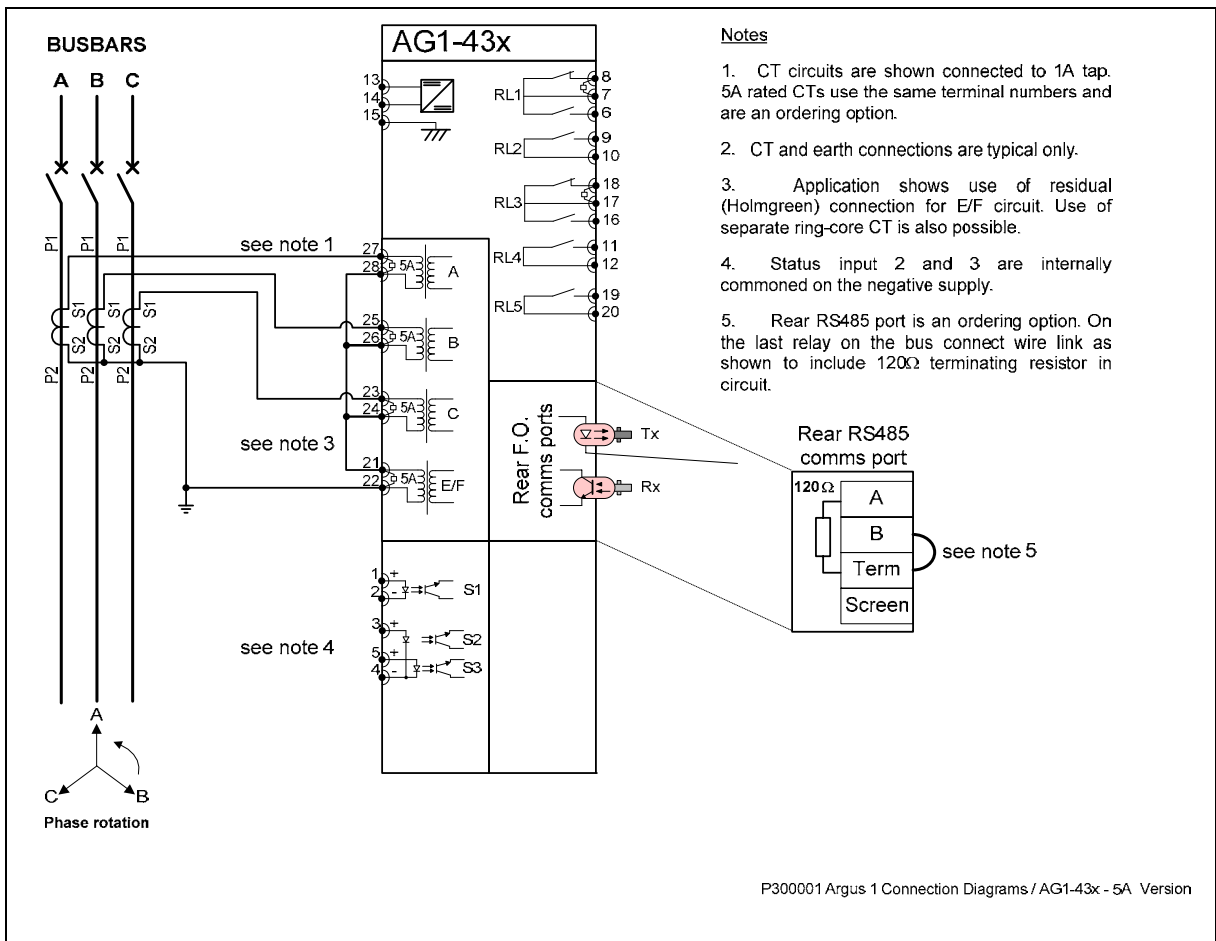


Figure 4-9 Typical Connection for 3 Phase-fault and Earth-fault Protection – 1A or 5A Version

# 7SG11Argus

Overcurrent Protection Relays

## Document Release History

This document is issue 2010/02. The list of revisions up to and including this issue is:

Pre release

2010/02	Document reformat due to rebrand
2006/03	Third issue: Editorial modifications, software revision histories updated
2004/05	Second issue: Addition of CBF, Demand metering settings and Modbus RTUprotocol
2002/12	First issue

The copyright and other intellectual property rights in this document, and in any model or article produced from it (and including any registered or unregistered design rights) are the property of Siemens Protection Devices Limited. No part of this document shall be reproduced or modified or stored in another form, in any data retrieval system, without the permission of Siemens Protection Devices Limited, nor shall any model or article be reproduced from this document unless Siemens Protection Devices Limited consent.

While the information and guidance given in this document is believed to be correct, no liability shall be accepted for any loss or damage caused by any error or omission, whether such error or omission is the result of negligence or any other cause. Any and all such liability is disclaimed.



## Software Release History

The software listed below is used in one of more types of Argus relay. The list of software revisions applying to Argus 2, up to and including this document issue is:

Nov 2005	2434H80040 R8	Highset and Lowset setting steps revised between 2.5xIn and 3.0xIn
July 2005	2434H80040 R7	ACD bit in IEC 60870 library corrected
Mar 2005	2434H80040 R6	CBF logic modified, timer will run while trip is being issued and I > ICBF Level
Aug 2004	2434H80040 R5	Modification to "checking settings" screen at switch on. Corrected "CT Failure" setting display when configured to show PRIMARY/SECONDARY Amps. ASDU4 measurands return value 0 correctly.
April 2004	2434H80023 R6	Minor change: Min P/F, E/F settings now 0.05 x In
Jan 2004	2434H80023 R5	Additional features: Modbus added Additional features: CT Failure function added
Sep 2003	2434H80023 R4	Minor change: IEC60870 Class 2 measurands Additional features: CBF Level detectors added
Mar 2003	2434H80023 R3	Minor change: DTL timers extended to 5 minutes
Nov 2002	2434H80023 R2	Minor change: Time synch via IEC870
Jun 2002	2434H80023 R1	Minor change: communications with ReyDisp
Feb 2002	2434H80022 R3	Minor change: power on alarm added
Oct 2001	2434H80022 R2	Additional features: CB fail (all models). Additional features: external trip via status input.
Feb 2001	2434H80022 R1	Minor change: SEF 2 <sup>nd</sup> stage can be disabled. Additional features: general alarms, status input inversion, resettable instruments, output relay pulse length setting, 10 second delay on trip test.
Apr 2000	2434H80021 R6	Additional features: CB fail, trip circuit supervision (single-pole models).
Jan 2000	2434H80021 R5	Additional features: New model variants
Jul 1999	2434H80021 R4	Minor change: current meter averaging.
May 1999	2434H80021 R3	Minor change: status group select
Mar 1998	2434H80020 R1	Additional features: default instruments Additional features: new expansion board (8SI). Additional features: clock synchronisation using status input Additional features: new directional SEF model and -90° characteristic angle available for E/F and SEF
Sep 1997	2434H80019 R4	Minor change: settings displayed in ReyDisp
Jul 1997	2434H80019 R3	Additional features: status input pick-up and drop-off delays added. Additional features: CB fail, trip circuit supervision (all expanded I/O models).
Apr 1997	2434H80018 R2	Minor change: separate settings for P/F, E/F and SEF current ratings. Minor change: sum of I <sup>2</sup> setting range. First release

### Argus 2-5xx software release history

April 2004	2434H80040 R4	Minor change: Min P/F, E/F settings now 0.05 x In
Jan 2004	2434H80040 R3	Additional Features: Added CT Failure functionality Maximum Demand Added for Ia, Ib, Ic, W, Vars General Alarms added to scrolling fault screen

		Settings added to configure the IEC60870 class2 measurands Added WHr and VArHr meters. Add setting to configure sign convention for export/import of power. Vb and Vn now displayed in fault screens in 3P+SEF variant. Vop can change setting group when starter is energised. MODBUS added. Added Ia,Ib,Ic,Ie,Isef,Va,Vb,Vc,Vn ASDU4 measurands for fault information. Timers extended to 300s CBF Level detectors added
Jul 2003	2434H80040 R2	Minor change: Sampling buffer modified
Apr 2003	2434H80040 R1	First Release

## Hardware Release History

The Argus hardware is used in many different relays. The list of hardware revisions applying to Argus 2, up to and including this document issue is:

Dec 2002	Additional features:	introduction of new models with star connected VTs
Mar 2002	Appearance change:	modification to grey fascia design – logo, dark grey band, buttons and label.
Jan 2002	External change:	SMA fibre-optic connectors replaced by ST <sup>TM</sup> (BFOC/2.5) by default.
Jul 1999	Appearance change:	introduction of grey fascia design to replace existing black fascia.
Jul 1999	External change:	introduction of Epsilon case and terminal blocks
Mar 1998	Additional features:	introduction of new expansion board (8SI).
Apr 1997	First release	

## Contents

<b>Software Release History .....</b>	<b>2</b>
<b>Hardware Release History .....</b>	<b>3</b>
<b>Contents .....</b>	<b>4</b>
<b>List of Figures .....</b>	<b>4</b>
<b>Section 1: Variants .....</b>	<b>5</b>
<b>Section 2: Settings .....</b>	<b>10</b>
<b>Section 3: IEC 60870-5-103 &amp; Modbus RTU Definitions .....</b>	<b>17</b>
3.1 IEC 60870-5-103 Definitions .....	17
3.2 Modbus RTU Definitions .....	24
<b>Section 4: Application Diagrams .....</b>	<b>30</b>

## List of Figures

Figure 2-1 Status Input and Output Relay Programming Matrix .....	16
Figure 4-1 Typical Connection for Directional Earth-fault Protection .....	30
Figure 4-2 Typical Connection for Directional Sensitive Earth-fault Protection .....	31
Figure 4-3 Typical Connection for 3 Directional Phase-fault Protection .....	31
Figure 4-4 Typical Connection for 2 Directional Phase-fault and Sensitive Earth-fault Protection .....	32
Figure 4-5 Typical Connection for 2 Directional P/F and Directional E/F Protection .....	32
Figure 4-6 Typical Connection for 2 Phase-fault and Directional Earth-fault Protection .....	33
Figure 4-7 Typical Connection for 3 Directional P/F and Directional E/F Protection .....	33
Figure 4-8 Typical Connection for 3 Directional Phase-fault and Sensitive Earth-fault Protection .....	34
Figure 4-9 Typical Connection for 3 Phase-fault and Directional Earth-fault Protection .....	34
Figure 4-10 Typical Connection of Type AG2-5xx Dir P/F and Dir E/F with Star-connected VT .....	35
Figure 4-11 Typical Connection of Type AG2-5xx Dir P/F and Dir E/F with Open-delta VT .....	35
Figure 4-12 Typical Connection of Type AG2-5xx Dir P/F and SEF with Star-connected VT .....	36
Figure 4-13 Typical Connection of Type AG2-5xx Dir P/F Dir E/F and SEF with Star-connected VT .....	36
Figure 4-14 Typical Connection of Type AG2-5xx Dir P/F, Dir E/F and SEF with Open-delta VT .....	37

## Section 1: Variants

This document applies to the Argus relays listed in the following MLFB Structure & table.

The MLFB Structure references the complete number for each relay:

- 7SG11nn-nxxnn-nxA0

where n is a digit and x is a letter.

The table uses two references for most relays, each of which is valid:

- an 'Order code' of the form AGn-*nnn*, and
- a 'Type' of the form DCD*nnn*X

where n is a digit and X is a letter.

Protection	Application Diagram	I/O	Order code / Type				
			30/48 aux.		110/220 aux.		
			30V status	48V status	48V status	110V status	220V status
Directional earth-fault	Fig. 4-1	1 SI 7 OR	DCD211A	<b>AG2-101</b> DCD213A	<b>AG2-102</b> DCD214A	DCD215A	DCD216A
Directional sensitive earth-fault	Fig. 4-2	1 SI 7 OR	DCD221A	<b>AG2-103</b> DCD223A	<b>AG2-104</b> DCD224A	DCD225A	DCD226A
3 directional phase-fault	Fig. 4-3	5 SI 11 OR	DCD611B	<b>AG2-311</b> DCD613B	<b>AG2-312</b> DCD614B	DCD615B	DCD616B
		9 SI 7 OR	DCD611C	<b>AG2-321</b> DCD613C	<b>AG2-322</b> DCD614C	DCD615C	DCD616C
2 directional phase-fault and SEF	Fig. 4-4	5 SI 11 OR	DCD621B	<b>AG2-313</b> DCD623B	<b>AG2-314</b> DCD624B	DCD625B	DCD626B
		9 SI 7 OR	DCD621C	<b>AG2-323</b> DCD623C	<b>AG2-324</b> DCD624C	DCD625C	DCD626C
2 directional phase-fault and directional earth-fault	Fig. 4-5	5 SI 11 OR	DCD631B	<b>AG2-315</b> DCD633B	<b>AG2-316</b> DCD634B	DCD635B	DCD636B
		9 SI 7 OR	DCD631C	<b>AG2-325</b> DCD633C	<b>AG2-326</b> DCD634C	DCD635C	DCD636C
2 phase-fault and dir'n. earth-fault	Fig. 4-6	5 SI 11 OR	DCD641B	<b>AG2-317</b> DCD643B	<b>AG2-318</b> DCD644B	DCD645B	DCD646B
		9 SI 7 OR	DCD641C	<b>AG2-327</b> DCD643C	<b>AG2-328</b> DCD644C	DCD645C	DCD646C
3 directional phase-fault and directional earth-fault	Fig. 4-7	5 SI 11 OR	DCD811B	<b>AG2-411</b> DCD813B	<b>AG2-412</b> DCD814B	DCD815B	DCD816B
		9 SI 7 OR	DCD811C	<b>AG2-421</b> DCD813C	<b>AG2-422</b> DCD814C	DCD815C	DCD816C
3 directional phase-fault and SEF	Fig. 4-8	5 SI 11 OR	DCD821B	<b>AG2-413</b> DCD823B	<b>AG2-414</b> DCD824B	DCD825B	DCD826B
		9 SI 7 OR	DCD821C	<b>AG2-423</b> DCD823C	<b>AG2-424</b> DCD824C	DCD825C	DCD826C
3 phase-fault and directional earth-fault	Fig. 4-9	5 SI 11 OR	DCD831B	<b>AG2-415</b> DCD833B	<b>AG2-416</b> DCD834B	DCD835B	DCD836B
		9 SI 7 OR	DCD831C	<b>AG2-425</b> DCD833C	<b>AG2-426</b> DCD834C	DCD835C	DCD836C
3 directional phase-fault and directional earth-fault under/overvoltage Voltage and power measurements	Fig. 4-10 Fig. 4-11	5 SI 11 OR	DCD911B	<b>AG2-511</b> DCD913B	<b>AG2-512</b> DCD914B	DCD915B	DCD916B
		9 SI 7 OR	DCD911C	<b>AG2-521</b> DCD913C	<b>AG2-522</b> DCD914C	DCD915C	DCD916C
3 dir'n. phase-fault and SEF, or 2 dir'n. P/F, dir'n. E/F and SEF and under/overvoltage Voltage and power measurements	Fig. 4-12 to Fig. 4-14	5 SI 11 OR	DCD921B	<b>AG2-513</b> DCD923B	<b>AG2-514</b> DCD924B	DCD925B	DCD926B
		9 SI 7 OR	DCD921C	<b>AG2-523</b> DCD923C	<b>AG2-524</b> DCD924C	DCD925C	DCD926C

## Ordering Information – 7SG1121 Argus 2

Product description	Variants	Order No.
<p>Directional O/C relay</p> <p>Ideal for directional overcurrent and earth fault protection of solid ring systems utilising the fully independent bi-directional feature.</p>	<p><b>Number of elements</b> Single pole relay</p> <p><b>Auxiliary supply/binary input voltage</b>                      24/30/48 V DC auxiliary, 30 V binary input                      110/220 V DC auxiliary, 30 V binary input                      24/30/48 V DC auxiliary, 48 V binary input                      110/220 V DC auxiliary, 48 V binary input <sup>1)</sup>                      110/220 V DC auxiliary, 110 V low burden binary input                      110/220 V DC auxiliary, 220 V low burden binary input</p> <p><b>Type of elements</b>                      Single pole earth-fault directional                      Single pole earth-fault directional                      Single pole sensitive/restricted directional earth-fault (SEF/REF)                      Single pole sensitive/restricted directional earth-fault (SEF/REF)</p> <p><b>Nominal current</b> 1/5 A</p> <p><b>I/O range</b> 1 Binary Input / 7 Binary Outputs (incl. 3 changeover)</p> <p><b>Communication interface</b>                      Fibre optic (ST-connector) / IEC 60870-5-103 or Modbus RTU                      RS485 interface / IEC 60870-5-103 or Modbus RTU</p> <p><b>Directional measurement characteristic angle (CA)</b>                      0°, -15°, -45°, -65° for earth faults                      0°, -15°, -45°, -90° for earth faults</p> <p><b>Housing size</b> Case size E4 (4U high)</p>	<p>7 S G 1 1 2 □ □ □ □ □ □ □ A 0</p> <p>↑ ↑ ↑ ↑ ↑ ↑ ↑ ↑</p> <p>1</p> <p>0</p> <p>1</p> <p>2</p> <p>3</p> <p>4</p> <p>5</p> <p>G</p> <p>G</p> <p>H</p> <p>H</p> <p>A</p> <p>0</p> <p>1</p> <p>2</p> <p>2</p> <p>3</p> <p>2</p> <p>3</p> <p>C</p>

<sup>1)</sup> High burden 110V & 220V binary inputs compliant with ESI48-4 ESI 1 available via external dropper resistors with 48V binary input version for 1 binary input and 110 V application, order resistor box VCE:2512H10066 in addition for 1 binary input and 220 V application, order resistor box VCE:2512H10068 in addition Refer to website for application note about ESI48-4 compliance

## Ordering Information – 7SG1123 Argus 2

Product description	Variants	Order No.	
<b>Directional O/C relay</b>  Ideal for directional overcurrent and earth fault protection of solid ring systems utilising the fully independent bi-directional feature.	<u>Number of elements</u> Three pole relay	7 S G 1 1 2 □ □ □ □ □ □ □ □ A 0	
	<u>Auxiliary supply/binary input voltage</u> 24/30/48 V DC auxiliary, 30 V binary input 110/220 V DC auxiliary, 30 V binary input 24/30/48 V DC auxiliary, 48 V binary input 110/220 V DC auxiliary, 48 V binary input 1) 110/220 V DC auxiliary, 110 V low burden binary input 110/220 V DC auxiliary, 220 V low burden binary input	3  0 1 2 3 4 5	
	<u>Type of elements</u> 3 pole phase-fault directional 2 pole phase-fault directional and sensitive/restricted earth-fault (SEF/REF) 2 pole phase-fault directional and earth-fault directional or 2 pole phase-fault directional and earth-fault 2 pole phase-fault directional and earth-fault directional or 2 pole phase-fault directional and earth-fault 2 pole phase-fault and earth-fault directional 2 pole phase-fault and earth-fault directional	K  L  L  M M	1 E 1 E  4 E 5 E  2 D 3 D
	<u>Nominal current</u> 1/ 5 A	A	
	<u>I/O range</u> 5 Binary Inputs / 11 Binary Outputs (incl. 3 changeover) 9 Binary Inputs / 7 Binary Outputs (incl. 3 changeover)	1 2	
	<u>Communication interface</u> Fibre optic (ST-connector) / IEC 60870-5-103 or Modbus RTU RS485 interface / IEC 60870-5-103 or Modbus RTU	1 2	
	<u>Directional measurement characteristic angle (CA)</u> +30°, +45° for phase faults 0°, -15°, -45°, -65° for earth faults 0°, -15°, -45°, -90° for earth faults +30°, +45° for phase faults and 0°, -15°, -45°, -65° for earth faults +30°, +45° for phase faults and 0°, -15°, -45°, -90° for earth faults	1 2 3 4 5	
	<u>Housing size</u> Case size E6 (4U high) Case size E8 (4U high)		D E

1) High burden 110V & 220V binary inputs compliant with ESI48-4 ESI 1 available via external dropper resistors with 48V binary input version for 5 binary inputs and 110 V application, order resistor box VCE:2512H10065 in addition for 9 binary inputs and 110 V application, order resistor box VCE:2512H10064 in addition for 5 binary inputs and 220 V application, order resistor box VCE:2512H10067 in addition for 9 binary inputs and 220 V application, order two resistor boxes VCE:2512H10067 in addition Refer to website for application note about ESI48-4 compliance

## Ordering Information – 7SG1124 Argus 2

Product description	Variants	Order No.
<p>Directional O/C relay</p> <p>Ideal for directional overcurrent and earth fault protection of solid ring systems utilising the fully independent bi-directional feature.</p>	<p><b>Number of elements</b> Four pole relay</p> <p><b>Auxiliary supply/binary input voltage</b>                      24/30/48 V DC auxiliary, 30 V binary input                      110/220 V DC auxiliary, 30 V binary input                      24/30/48 V DC auxiliary, 48 V binary input                      110/220 V DC auxiliary, 48 V binary input <sup>1)</sup>                      110/220 V DC auxiliary, 110 V low burden binary input                      110/220 V DC auxiliary, 220 V low burden binary input</p> <p><b>Type of elements</b>                      3 pole phase-fault directional and sensitive/restricted earth-fault (SEF/REF)                      3 pole phase-fault directional and earth-fault directional or 3 pole phase-fault directional and earth-fault                      3 pole phase-fault directional and earth-fault directional or 3 pole phase-fault directional and earth-fault                      3 pole phase-fault and earth-fault directional                      3 pole phase-fault and earth-fault directional</p> <p><b>Nominal current</b> 1/ 5 A</p> <p><b>I/O range</b>                      5 Binary Inputs / 11 Binary Outputs (incl. 3 changeover)                      9 Binary Inputs / 7 Binary Outputs (incl. 3 changeover)</p> <p><b>Communication interface</b>                      Fibre optic (ST-connector) / IEC 60870-5-103 or Modbus RTU                      RS485 interface / IEC 60870-5-103 or Modbus RTU</p> <p><b>Directional measurement characteristic angle (CA)</b>                      +30°, +45° for phase faults                      0°, -15°, -45°, -65° for earth faults                      0°, -15°, -45°, -90° for earth faults                      +30°, +45° for phase faults and 0°, -15°, -45°, -65° for earth faults                      +30°, +45° for phase faults and 0°, -15°, -45°, -90° for earth faults</p> <p><b>Housing size</b>                      Case size E6 (4U high)                      Case size E8 (4U high)</p>	<p>7 S G 1 1 2 □ □ □ □ □ □ □ A 0</p>

<sup>1)</sup> High burden 110V & 220V binary inputs compliant with ESI48-4 ESI 1 available via external dropper resistors with 48V binary input version for 5 binary inputs and 110 V application, order resistor box VCE:2512H10065 in addition for 9 binary inputs and 110 V application, order resistor box VCE:2512H10064 in addition for 5 binary inputs and 220 V application, order resistor box VCE:2512H10067 in addition for 9 binary inputs and 220 V application, order two resistor boxes VCE:2512H10067 in addition Refer to website for application note about ESI48-4 compliance

## Ordering Information – 7SG1125 Argus 2

Product description	Variants	Order No.
<p>Directional O/C relay</p> <p>Ideal for directional overcurrent and earth fault protection of solid ring systems utilising the fully independent bi-directional feature, includes additional voltage protection and energy metering.</p>	<p><b>Number of elements</b> Four pole relay (numeric VT)</p> <p><b>Auxiliary supply/binary input voltage</b> 24/30/48 V DC auxiliary, 30 V binary input 110/220 V DC auxiliary, 30 V binary input 24/30/48 V DC auxiliary, 48 V binary input 110/220 V DC auxiliary, 48 V binary input <sup>1)</sup> 110/220 V DC auxiliary, 110 V low burden binary input 110/220 V DC auxiliary, 220 V low burden binary input</p> <p><b>Type of elements</b> 3 pole phase-fault directional and earth-fault directional 3 pole phase-fault directional and sensitive/restricted earth fault (SEF/REF) or 2 pole phase-fault directional and earth fault directional and sensitive/restricted earth-fault (SEF/REF)</p> <p><b>Nominal current</b> 1/5 A and 63/110 V AC</p> <p><b>I/O range</b> 5 Binary Inputs / 11 Binary Outputs (incl. 3 changeover) 9 Binary Inputs / 7 Binary Outputs (incl. 3 changeover)</p> <p><b>Communication interface</b> Fibre optic (ST-connector) / IEC 60870-5-103 or Modbus RTU RS485 interface / IEC 60870-5-103 or Modbus RTU</p> <p><b>Directional measurement characteristic angle (CA)</b> -90° to +90° in steps of 1°</p> <p><b>Housing size</b> Case size E8 (4U high)</p>	<p>7 S G 1 1 2 □ □ □ □ □ □ □ A 0</p> <p style="font-size: 2em;">↑ ↑ ↑ ↑ ↑ ↑ ↑ ↑</p> <p>5</p> <p>0</p> <p>1</p> <p>2</p> <p>3</p> <p>4</p> <p>5</p> <p>R</p> <p>S</p> <p>D</p> <p>1</p> <p>2</p> <p>1</p> <p>2</p> <p>6</p> <p>E</p>

<sup>1)</sup> High burden 110V & 220V binary inputs compliant with ESI48-4 ESI 1 available via external dropper resistors with 48V binary input version for 5 binary inputs and 110 V application, order resistor box VCE:2512H10065 in addition for 9 binary inputs and 110 V application, order resistor box VCE:2512H10064 in addition for 5 binary inputs and 220 V application, order resistor box VCE:2512H10067 in addition for 9 binary inputs and 220 V application, order two resistor boxes VCE:2512H10067 in addition Refer to website for application note about ESI48-4 compliance



## Section 2: Settings

Relay Type \_\_\_\_\_

Serial Number \_\_\_\_\_

Substation \_\_\_\_\_

Feeder Identity \_\_\_\_\_

### Notes on Tables

All settings found in the Argus 2 relay types are listed below. Within the list some settings (indicated with greyed cells) are not always visible, for the following reasons:

- Depending on the version of the relay, a particular function and hence its related settings may not be present, e.g. on a 2 phase-fault and SEF relay any settings related to earth-fault will not be present.
- Depending on the value of some settings, other settings will be hidden, e.g. if the main characteristic is set to DTL, rather than an IDMT characteristic, the time multiplier setting will be hidden and replaced by a time delay setting.

Some settings in the tables show text in square brackets, e.g. '[SEF/REF] Current Setting'. This indicates different text that may be displayed, depending on the value of other settings, i.e. 'SEF Current Setting' or 'REF Current Setting' dependent on the value of the 'Earth Fault Mode Select' setting.

The second column in the tables ('Ref') provides a reference to the section in the Technical Reference (publication P20007 issue 2004/02) that describes the setting.



The third column is left blank to allow users to complete the table with applied settings.















### System Config. Menu











Setting name	Ref	Applied value
Active Settings Group	2.2.1	
Settings Group Edit/View	2.2.1	
Copy Group	2.2.1	
Power System Frequency	2.2.2	Hz
Set Pole B Type	2.2.3	
Earth Fault Mode Select	2.2.3	
Phase Rotation	2.2.3	
P/F Rating (In)	2.2.3	A
E/F Rating (In)	2.2.3	A
[SEF/REF] Rating (In)	2.2.3	A
P/F CT Ratio	2.2.3	
E/F CT Ratio	2.2.3	
[SEF/REF] CT Ratio	2.2.3	
VT Connection	2.2.3	
VT Primary	2.2.3	
VT Secondary	2.2.3	

Setting name	Ref	Applied value
Current Display	2.2.3	
Export Power/Lag VAr Sign	2.2.3	
Set Identifier	2.2.4	
Set Alarm 1	2.2.5	
Set Alarm 2	2.2.5	
Set Alarm 3	2.2.5	
Set Alarm 4	2.2.5	
Set Alarm 5	2.2.5	
FWD Name Tag	2.2.6	
REV Name Tag	2.2.6	
Calendar – Set Date	2.2.7	
Clock - Set Time	2.2.7	
Clock Sync. From Status	2.2.7	
Default Screen Time	2.2.8	
Change Password	2.2.9	

**Protection Menu**

For non-directional settings use the Gn[] settings, ignoring the forward () notation.

Setting name	Ref	Applied value
Gn P/F Charact. Dir Control	2.3.1	
Gn[  ] P/F Charact. Setting	2.3.1	xIn
Gn[  ] P/F Charact.	2.3.1	
Gn[  ] P/F Charact. Time Mult	2.3.1	
Gn[  ] P/F Charact. Delay	2.3.1	sec
Gn <sup>R</sup> P/F Charact. Setting	2.3.1	xIn
Gn <sup>R</sup> P/F Charact.	2.3.1	
Gn <sup>R</sup> P/F Charact. Time Mult	2.3.1	
Gn <sup>R</sup> P/F Charact. Delay	2.3.1	sec
Gn P/F Lowset Dir Control	2.3.2	
Gn[  ] P/F Lowset Setting	2.3.2	xIn
Gn[  ] P/F Lowset Delay	2.3.2	sec
Gn <sup>R</sup> P/F Lowset Setting	2.3.2	xIn
Gn <sup>R</sup> P/F Lowset Delay	2.3.2	sec
Gn P/F Highset1 Dir Control	2.3.2	
Gn[  ] P/F Highset1 Setting	2.3.2	xIn
Gn[  ] P/F Highset1 Delay	2.3.2	sec
Gn <sup>R</sup> P/F Highset1 Setting	2.3.2	xIn
Gn <sup>R</sup> P/F Highset1 Delay	2.3.2	sec
Gn P/F Highset2 Dir Control	2.3.2	
Gn[  ] P/F Highset2 Setting	2.3.2	xIn
Gn[  ] P/F Highset2 Delay	2.3.2	sec
Gn <sup>R</sup> P/F Highset2 Setting	2.3.2	xIn
Gn <sup>R</sup> P/F Highset2 Delay	2.3.2	sec
Gn E/F Charact. Dir Control	2.3.1	
Gn[  ] E/F Charact. Setting	2.3.1	xIn
Gn[  ] E/F Charact.	2.3.1	
Gn[  ] E/F Charact. Time Mult	2.3.1	
Gn[  ] E/F Charact. Delay	2.3.1	sec
Gn <sup>R</sup> E/F Charact. Setting	2.3.1	xIn
Gn <sup>R</sup> E/F Charact.	2.3.1	

Setting name	Ref	Applied value
Gn <sup>R</sup> E/F Charact. Time Mult	2.3.1	
Gn <sup>R</sup> E/F Charact. Delay	2.3.1	sec
Gn E/F Lowset Dir Control	2.3.2	
Gn[  ] E/F Lowset Setting	2.3.2	xIn
Gn[  ] E/F Lowset Delay	2.3.2	sec
Gn <sup>R</sup> E/F Lowset Setting	2.3.2	xIn
Gn <sup>R</sup> E/F Lowset Delay	2.3.2	sec
Gn E/F Highset1 Dir Control	2.3.2	
Gn[  ] E/F Highset1 Setting	2.3.2	xIn
Gn[  ] E/F Highset1 Delay	2.3.2	sec
Gn <sup>R</sup> E/F Highset1 Setting	2.3.2	xIn
Gn <sup>R</sup> E/F Highset1 Delay	2.3.2	sec
Gn E/F Highset2 Dir Control	2.3.2	
Gn[  ] E/F Highset2 Setting	2.3.2	xIn
Gn[  ] E/F Highset2 Delay	2.3.2	sec
Gn <sup>R</sup> E/F Highset2 Setting	2.3.2	xIn
Gn <sup>R</sup> E/F Highset2 Delay	2.3.2	sec
Gn SEF/REF Dir Control	2.4	xIn
Gn[  ] SEF/REF Current Setting	2.4	xIn
Gn[  ] SEF/REF 1st Time Delay	2.4	sec
Gn[  ] SEF/REF 2nd Time Delay	2.4	sec
Gn[  ] SEF/REF Lowset Delay	2.4	sec
Gn <sup>R</sup> SEF/REF Current Setting	2.4	xIn
Gn <sup>R</sup> SEF/REF 1st Time Delay	2.4	sec
Gn <sup>R</sup> SEF/REF 2nd Time Delay	2.4	sec
Gn <sup>R</sup> SEF/REF Lowset Delay	2.4	sec
Gn CB Fail Time Delay1	2.5	sec
Gn CB Fail Time Delay2	2.5	sec
Gn P/F CB Fail Setting	2.5	xIn
Gn E/F CB Fail Setting	2.5	xIn
Gn SEF CB Fail Setting	2.5	xIn
Gn CT Failure Setting	2.5.3	xIn
Gn CT Failure Delay	2.5.3	sec

Setting name	Ref	Applied value
Gn Relay Reset Delay	2.3.3	sec

### Directional Menu

Setting name	Ref	Applied value
Gn 2-Out-Of-3 Gate Logic	2.7	
Gn P/F Charact. Angle	2.7	
Gn E/F Charact. Angle	2.7	
Gn SEF Charact. Angle	2.7	
Voltage Memory	2.7.3	

### Voltage Menu

*Argus 2 type 2 only*

Setting name	Ref	Applied value
Gn V Operation	2.8	
Gn V [ph-n/ph-ph] Setting	2.8	
Gn V Delay	2.8	
Gn V Hysteresis	2.8	
V Block Threshold	2.8	
V O/P Phases	2.8	

### Output Relay Configuration Menu

See also Figure 2-1 on page 16 for the programming matrix. For non-directional settings use the Gn [F] settings, ignoring the forward (F) notation.

Setting name	Ref	Applied value
Gn Prot. Healthy	2.14.3	
Gn [F] P/F Starter	2.3.1	
Gn [R] P/F Starter	2.3.1	
Gn [F] P/F Charact.	2.3.1	
Gn [R] P/F Charact.	2.3.1	
Gn [F] P/F Lowset	2.3.2	
Gn [R] P/F Lowset	2.3.2	
Gn [F] P/F Highset1	2.3.2	
Gn [R] P/F Highset1	2.3.2	
Gn [F] P/F Highset2	2.3.2	
Gn [R] P/F Highset2	2.3.2	

Setting name	Ref	Applied value
Gn [F] E/F Starter	2.3.1	
Gn [R] E/F Starter	2.3.1	
Gn [F] E/F Charact.	2.3.1	
Gn [R] E/F Charact.	2.3.1	
Gn [F] E/F Lowset	2.3.2	
Gn [R] E/F Lowset	2.3.2	
Gn [F] E/F Highset1	2.3.2	
Gn [R] E/F Highset1	2.3.2	
Gn [F] E/F Highset2	2.3.2	
Gn [R] E/F Highset2	2.3.2	
Gn [F] SEF/REF Starter	2.4	
Gn [F] SEF/REF Delay 1	2.4	
Gn [F] SEF/REF Delay 2	2.4	
Gn [F] SEF/REF Lowset	2.4	
Gn [R] SEF/REF Starter	2.4	
Gn [R] SEF/REF Delay 1	2.4	
Gn [R] SEF/REF Delay 2	2.4	
Gn [R] SEF/REF Lowset	2.4	
Gn P/F FWD Block	2.7	
Gn P/F REV Block	2.7	
Gn [E/F / SEF] FWD Block	2.7	
Gn [E/F / SEF] REV Block	2.7	
Gn V Starter	2.8	
Gn V Trip	2.8	
Gn V Block Alarm	2.8	
Gn Status 1	2.11	
Gn Status 2	2.11	
Gn Status 3	2.11	
Gn Status 4	2.11	
Gn Status 5	2.11	
Gn Status 6	2.11	
Gn Status 7	2.11	
Gn Status 8	2.11	

Setting name	Ref	Applied value
Gn Status 9	2.11	
Gn CB Fail 1	2.5	
Gn CB Fail 2	2.5	
Gn CT Failure	2.5.3	
Gn Counter Alarm	2.14.1	
Gn $\Sigma I^2$ Alarm	2.14.1	
Gn PowerOn Count	2.14.3	
Gn Hand Reset	2.11	
Min O/P Energise Time	2.11	ms

### Status Configuration Menu

See also Figure 2-1 on page 16 for the programming matrix.

Setting name	Ref	Applied value
Settings Group Select	2.2.1	
Inverted Inputs	2.11	
Gn P/F Charact. Inhibit	2.3.1	
Gn P/F Lowset Inhibit	2.3.2	
Gn P/F Highset1 Inhibit	2.3.2	
Gn P/F Highset2 Inhibit	2.3.2	
Gn E/F Charact. Inhibit	2.3.1	
Gn E/F Lowset Inhibit	2.3.2	
Gn E/F HighSet 1 Inhibit	2.3.2	
Gn E/F HighSet 2 Inhibit	2.3.2	
Gn SEF/REF Delay 1 Inhibit	2.4	
Gn SEF/REF Delay 2 Inhibit	2.4	
Gn SEF/REF Lowset Inhibit	2.4	
Gn V Inhibit	2.8	
Gn Trip Circuit Fail	2.10	
Gn Waveform Trig	2.13.3	
Gn $\Sigma I^2$ Update	2.14.1	
Gn Reset Flag & Outputs	2.11	
Gn Clock Sync.	2.2.7	

Setting name	Ref	Applied value
Gn Status 1 P/U Delay	2.11	sec
Gn Status 1 D/O Delay	2.11	sec
Gn Status 2 P/U Delay	2.11	sec
Gn Status 2 D/O Delay	2.11	sec
Gn Status 3 P/U Delay	2.11	sec
Gn Status 3 D/O Delay	2.11	sec
Gn Status 4 P/U Delay	2.11	sec
Gn Status 4 D/O Delay	2.11	sec
Gn Status 5 P/U Delay	2.11	sec
Gn Status 5 D/O Delay	2.11	sec
Gn Status 6 P/U Delay	2.11	sec
Gn Status 6 D/O Delay	2.11	sec
Gn Status 7 P/U Delay	2.11	sec
Gn Status 7 D/O Delay	2.11	sec
Gn Status 8 P/U Delay	2.11	sec
Gn Status 8 D/O Delay	2.11	sec
Gn Status 9 P/U Delay	2.11	sec
Gn Status 9 D/O Delay	2.11	sec
Gn Alarm 1 * see note below	2.2.5	
Gn Alarm 2 * see note below	2.2.5	
Gn Alarm 3 * see note below	2.2.5	
Gn Alarm 4 * see note below	2.2.5	
Gn Alarm 5 * see note below	2.2.5	

\* The text of these setting names reflects the value applied to the 'Set Alarm *n*' settings in the 'System Config.' menu.

### Comms Interface Menu

Setting name	Ref	Applied value
Comms Protocol	4.1.1	
IEC Class 2 Measurand	4.2.6	
Class 2 Update	4.2.7	sec
IEC Class 2 Scaling	4.2.8	
Comms Baud Rate	4.2.9	baud
Comms Parity	4.2.10	

Setting name	Ref	Applied value
Relay Address	4.2.11	
Line Idle	4.2.12	
Data Echo	4.2.13	

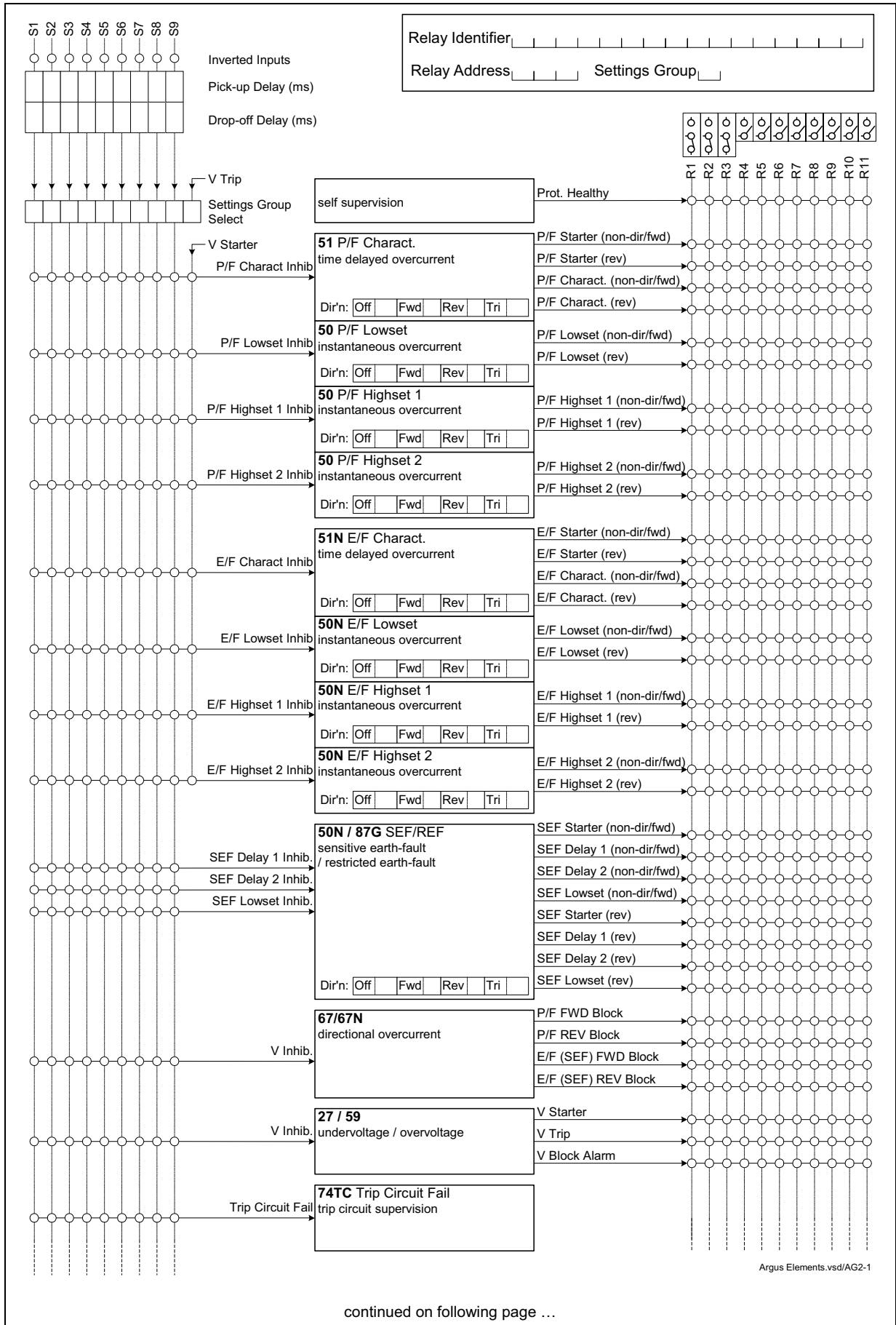
#### Data Storage Menu

Setting name	Ref	Applied value
Gn Fault Trigger	2.13.2	
Gn Waveform Trig	2.13.3	
Gn Waveform Pre-trigger	2.13.3	%
Clear All Waveforms	2.13.3	
Clear All Events	2.13.1	
Clear All Faults	2.13.2	
Demand Window Type	2.13.4	
Demand Window	2.13.4	

Setting name	Ref	Applied value
Maximum Demand Reset	2.13.4	

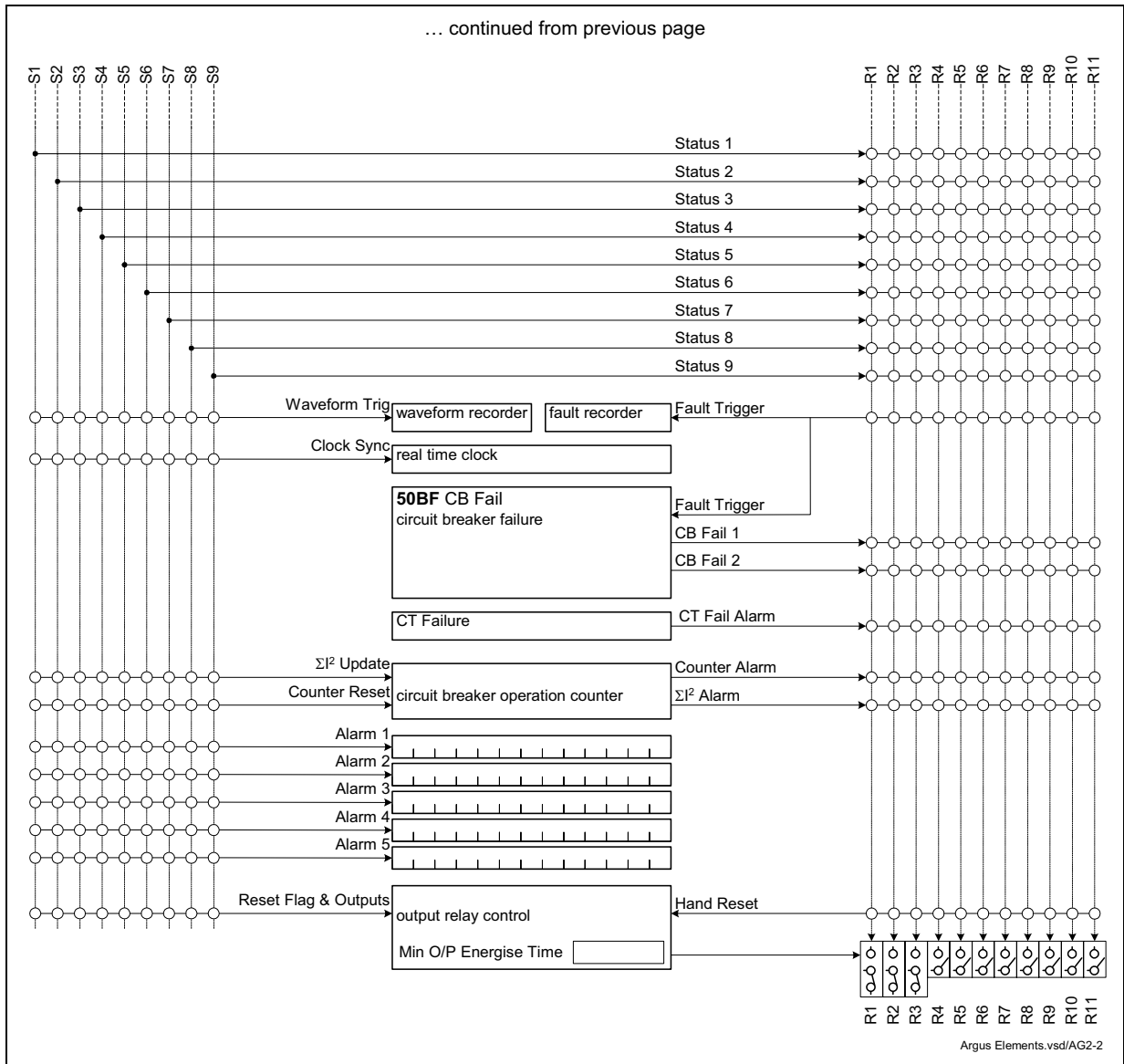
#### CB Maintenance Menu

Setting name	Ref	Applied value
Trip Counter Reset	2.14.1	
Trip Counter Alarm	2.14.1	
$\Sigma I^2$ Reset	2.14.1	
$\Sigma I^2$ Alarm	2.14.1	
Power On Count Reset	2.14.3	
Power On Count Alarm	2.14.3	
Energy Meter Reset	2.14.1	
O/P Relay Test	2.14.2	



Argus Elements.vsd/AG2-1

continued on following page ...



**Figure 2-1 Status Input and Output Relay Programming Matrix**

## Section 3: IEC 60870-5-103 & Modbus RTU Definitions

### 3.1 IEC 60870-5-103 Definitions

The following tables give information on the IEC 60870-5-103 protocol. A detailed description of all protocol information is available in report no 434/TM/5/13 which can be accessed on the [www.reyrolle-protection.com](http://www.reyrolle-protection.com) in publications section under technical reports, "communications interface manual".

**Table Showing Function Type Numbers Used**

Function Type	Description
160	IEC Overcurrent Protection
164	Reyrolle Overcurrent Protection
254	IEC Generic
255	IEC Global

#### Cause of Transmission

The cause of transmission (COT) column of the 'Information Number and Function' table lists possible causes of transmission for these frames. The following abbreviations are used:

**Table Showing Permitted Cause of Transmission Numbers**

Cause of Transmission (COT)	Description
1	Spontaneous Events
2	Cyclic
3	Reset Frame Count Bit (FCB)
4	Reset Communication Unit (CU)
5	Start Restart
6	Power On
7	Test Mode
8	Time Synchronisation
9	General Interrogation
10	Termination of General Interrogation
11	Local Operation
12	Remote Operation
20	Positive Command Acknowledge
21	Negative Command Acknowledge
31	Transmission of Disturbance Data

#### Information Number and Function

The following tables list information number and function definitions together with a description of the message and function type and cause of transmission that can result in that message. Not all definitions are available on all relay types – this is dependent on functionality.

<b>KEY</b>	<b>FUN</b>	Function Type (defined in IEC60870-5-103 section 7.2.5.1)
	<b>INF</b>	Information Number (defined in IEC60870-5-103 section 7.2.5.2)
	<b>TYP</b>	ASDU Type (defined in IEC60870-5-103 sections 7.3.1 and 7.3.2)
	<b>GI</b>	Event supports General Interrogation x = supported (defined in IEC60870-5-103 section 7.2.5.2)
	<b>COM</b>	Type of command single (ON only) or double (ON/OFF) (defined in IEC60870-5-103 section 7.2.5.2)
	<b>COT</b>	Cause of Transmission (defined in IEC60870-5-103 section 7.2.3, table 5)
	<b>DIR</b>	Direction of event - Raised Only (RO), Raised/Cleared (RC) or Double Point Travelling, Cleared, Raised or Unknown (DBI)
	<b>x</b>	Supported, - Not supported.



Table Showing Command Information (INF) Numbers

FUN	INF	Description	GI	TYP	COT	DIR	AG 2	AG 2 - 500
160	2	Reset FCB	-	5	3	RO	x	x
160	3	Reset CU	-	5	4	RO	x	x
160	4	Start/Restart	-	5	5	RO	x	x
160	5	Power On	-	5	6	RO	x	x
160	16	ARC in progress	x	1	1, 9, 12, 20, 21	RC		
160	19	LEDs reset	-	1	1, 7, 11, 12, 20, 21	RO	x	x
160	21	Trip Test	x	1	1, 9	RC	x	x
160	22	Settings changed	x	1	1, 9, 11, 12	RC	x	x
160	23	Setting G1 selected	x	1	1, 9, 11, 12, 20, 21	RC	x	x
160	24	Setting G2 selected	x	1	1, 9, 11, 12, 20, 21	RC	x	x
160	25	Setting G3 selected	x	1	1, 9, 11, 12, 20, 21	RC	x	x
160	26	Setting G4 selected	x	1	1, 9, 11, 12, 20, 21	RC	x	x
160	27	Input 1	x	1	1, 9	RC	x	x
160	28	Input 2	x	1	1, 9	RC	x	x
160	29	Input 3	x	1	1, 9	RC	x	x
160	30	Input 4	x	1	1, 9	RC	x	x
160	36	Trip circuit fail	x	1	1, 9	RC	x	x
160	46	Group Warning	x	1	1, 9	RC		
160	47	Alarm	x	1	1, 9	RO		
160	64	A-starter	x	2	1, 9	RC	x	x
160	65	B-starter	x	2	1, 9	RC	x	x
160	66	C-starter	x	2	1, 9	RC	x	x
160	67	E-starter	x	2	1, 9	RC	x	x
160	68	General trip	-	2	1	RO	x	x
160	69	A-general trip	-	2	1	RO	x	x
160	70	B-general trip	-	2	1	RO	x	x
160	71	C-general trip	-	2	1	RO	x	x
160	84	General starter	x	2	1, 9	RC	x	x
160	85	Circuit breaker fail 1	-	2	1	RO	x	x
160	91	P/F-general HS trip	-	2	1	RO	x	x
160	92	E/F-general trip	-	2	1	RO	x	x

FUN	INF	Description	GI	TYP	COT	DIR	AG 2	AG 2 - 500
160	93	E/F-general HS trip	-	2	1	RO	x	x
160	128	CB on by auto reclose	-	1	1	DP		
160	130	Reclose blocked	x	1	1, 9	RC		
160	144	Measurand I <sup>1</sup>	-	3.1	2,7	-	x	x
160	148	Measurand I <sub>L1,2,3</sub> , V <sub>L1,2,3</sub> , P, Q	-	9	2,7	-	x	x
164	0	Data lost	-	1	1	RO	x	x
164	1	A-lowset starter	-	2	1	RC	x	x
164	2	B-lowset starter	-	2	1	RC	x	x
164	3	C-lowset starter	-	2	1	RC	x	x
164	4	E-lowset starter	-	2	1	RC	x	x
164	5	A-lowset trip	-	2	1	RO	x	x
164	6	B-lowset trip	-	2	1	RO	x	x
164	7	C-lowset trip	-	2	1	RO	x	x
164	8	E-lowset trip	-	2	1	RO	x	x
164	9	A-delayed trip	-	2	1	RO	x	x
164	10	B-delayed trip	-	2	1	RO	x	x
164	11	C-delayed trip	-	2	1	RO	x	x
164	12	E-delayed trip	-	2	1	RO	x	x
164	13	A-HS1 trip	-	2	1	RO	x	x
164	14	B-HS1 trip	-	2	1	RO	x	x
164	15	C-HS1 trip	-	2	1	RO	x	x
164	16	E-HS1 trip	-	2	1	RO	x	x
164	17	A-HS2 trip	-	2	1	RO	x	x
164	18	B-HS2 trip	-	2	1	RO	x	x
164	19	C-HS2 trip	-	2	1	RO	x	x
164	20	E-HS2 trip	-	2	1	RO	x	x
164	21	SEF/REF starter	x	2	1, 9	RC	x	x
164	23	SEF/REF lowset trip	-	2	1	RC	x	x
164	24	SEF/REF stage 1 trip	-	2	1	RC	x	x
164	25	SEF/REF stage 2 trip	-	2	1	RC	x	x
164	26	A-HS1 starter	-	2	1	RC	x	x
164	27	B-HS1 starter	-	2	1	RC	x	x
164	28	C-HS1 starter	-	2	1	RC	x	x

<sup>1</sup> One of Ia, Ib, Ic, Id depending on relay type

FUN	INF	Description	GI	TYP	COT	DIR	AG 2	AG 2 - 500
164	29	E-HS1 starter	-	2	1	RC	x	x
164	30	A-HS2 starter	-	2	1	RC	x	x
164	31	B-HS2 starter	-	2	1	RC	x	x
164	32	C-HS2 starter	-	2	1	RC	x	x
164	33	E-HS2 starter	-	2	1	RC	x	x
164	34	Circuit breaker open	x	1	1, 9	RO		
164	35	Setting G5 selected	x	1	1, 9, 11, 12, 20, 21	RC	x	x
164	36	Setting G6 selected	x	1	1, 9, 11, 12, 20, 21	RC	x	x
164	37	Setting G7 selected	x	1	1, 9, 11, 12, 20, 21	RC	x	x
164	38	Setting G8 selected	x	1	1, 9, 11, 12, 20, 21	RC	x	x
164	39	Circuit breaker fail 2	-	2	1	RO	x	x
164	41	CB close fail	x	1	1, 9	RO		
164	43	CB DBI state	x	1	1, 9	RO		
164	44	External Trip	-	2	1	RO	x	x
164	45	Input 5	x	1	1, 9	RC	x	x
164	46	Input 6	x	1	1, 9	RC	x	x
164	47	Input 7	x	1	1, 9	RC	x	x
164	48	Input 8	x	1	1, 9	RC	x	x
164	49	Input 9	x	1	1, 9	RC	x	x
164	51	Output 1	x	1	1, 9, 12, 20, 21	RC	x	x
164	52	Output 2	x	1	1, 9, 12, 20, 21	RC	x	x
164	53	Output 3	x	1	1, 9, 12, 20, 21	RC	x	x
164	54	Output 4	x	1	1, 9, 12, 20, 21	RC	x	x
164	55	Output 5	x	1	1, 9, 12, 20, 21	RC	x	x
164	56	Output 6	x	1	1, 9, 12, 20, 21	RC	x	x
164	57	Output 7	x	1	1, 9, 12, 20, 21	RC	x	x
164	58	Output 8	x	1	1, 9, 12, 20, 21	RC	x	x
164	59	Output 9	x	1	1, 9, 12, 20, 21	RC	x	x
164	60	Output 10	x	1	1, 9, 12, 20, 21	RC	x	x
164	61	Output 11	x	1	1, 9, 12, 20, 21	RC	x	x
164	62	Forward A	x	2	1, 9	RC	x	x
164	63	Reverse A	x	2	1, 9	RC	x	x
164	64	Forward B	x	2	1, 9	RC	x	x
164	65	Reverse B	x	2	1, 9	RC	x	x
164	66	Forward C	x	2	1, 9	RC	x	x
164	67	Reverse C	x	2	1, 9	RC	x	x
164	68	Forward E	x	2	1, 9	RC	x	x
164	69	Reverse E	x	2	1, 9	RC	x	x

FUN	INF	Description	GI	TYP	COT	DIR	AG 2	AG 2 - 500
164	70	Trip count alarm	x	1	1, 9	RC	x	x
164	70	Trip count alarm	x	4	1, 9	-	x	x
164	71	CB maintenance alarm	x	1	1, 9	RC	x	x
164	71	CB maintenance alarm	x	4	1, 9	-	x	x
164	72	Frequent operations exceeded	x	1	1, 9	RC		
164	73	Delta Trip Counter Alarm	x	1	1, 9	RC		
164	79	Voltage Block	x	1	1, 9	RC		x
164	80	Waveform stored	-	1	1, 12, 20, 21	RO	x	x
164	81	Remote control interrupted	-	1	1	RO	x	x
164	82	Trip and Lockout	-	1	1, 12, 20, 21	RO		
164	83	Close and Reclaim	-	1	1, 12, 20, 21	RO		
164	84	Trip And Reclose	-	1	1, 12, 20, 21	RO		
164	85	Circuit breaker closed	x	1	1, 9	RO		
164	86	Close And Lockin	-	1	1, 12, 20, 21	RO		
164	87	Reclose delay	x	1	1, 9	RC		
164	88	Reclaim	x	1	1, 9	RC		
164	89	Lockout	x	1	1, 9	RC		
164	90	Forward SEF	x	2	1, 9	RC	x	
164	91	Reverse SEF	x	2	1, 9	RC	x	
164	92	Power On Counter Alarm	x	1	1, 9	RC	x	x
164	97	CT Failure	x	1	1, 9	RC	x	x
164	100	Cold load pickup	x	1	1, 9, 12, 20, 21	RC		
164	101	Cold load trip	-	2	1	RO		
164	102	Line check trip	-	2	1	RO		
164	103	ARC start A	x	1	1, 9	RC		
164	104	A backup time	-	1	1	RC		
164	105	A backup trip	-	1	1	RC		
164	106	External trip block	x	1	1, 9	RC		
164	110	SEF off	x	1	1, 9, 12, 20, 21	RC		
164	111	All ARC off	x	1	1, 9	RC		
164	112	P/F ARC off	x	1	1, 9, 12, 20, 21	RC		
164	113	E/F ARC off	x	1	1, 9, 12, 20, 21	RC		
164	114	SEF ARC off	x	1	1, 9, 12, 20, 21	RC		
164	115	All inst off	x	1	1, 9, 12, 20, 21	RC		
164	116	P/F inst off	x	1	1, 9, 12, 20, 21	RC		
164	117	E/F inst off	x	1	1, 9, 12, 20, 21	RC		

FUN	INF	Description	GI	TYP	COT	DIR	AG 2	AG 2 - 500
164	118	SEF inst off	x	1	1, 9, 12, 20, 21	RC		
164	119	Hot line working	x	1	1, 9, 12, 20, 21	RC		
164	120	Scada Control	x	1	1, 9	RC		
164	121	General alarm 1	x	1	1, 9	RC	x	x
164	122	General alarm 2	x	1	1, 9	RC	x	x
164	123	General alarm 3	x	1	1, 9	RC	x	x
164	124	General alarm 4	x	1	1, 9	RC	x	x
164	125	General alarm 5	x	1	1, 9	RC	x	x
164	131	Va/Vab starter	x	2	1, 9	RC		x
164	132	Vb/Vbc starter	x	2	1, 9	RC		x
164	133	Vc/Vca starter	x	2	1, 9	RC		x
164	170	V starter	x	2	1, 9	RC		x
164	182	V trip	-	2	1	RO		x
164	190	Voltage Memory A	x	1	1, 9	RC		x
164	191	Voltage Memory B	x	1	1, 9	RC		x
164	192	Voltage Memory C	x	1	1, 9	RC		x
164	240	Ia Fault Current	x	4	1, 9	-	x	x
164	241	Ib Fault Current	x	4	1, 9	-	x	x
164	242	Ic Fault Current	x	4	1, 9	-	x	x
164	243	Ie Fault Current	x	4	1, 9	-	x	x
164	244	Isef Fault Current	x	4	1, 9	-	x	x
164	245	Va Fault Voltage	x	4	1, 9	-		x
164	246	Vb Fault Voltage	x	4	1, 9	-		x
164	247	Vc Fault Voltage	x	4	1, 9	-		x
164	248	Vn Fault Voltage	x	4	1, 9	-		x
255	0	Time Synchronisation	-	6	8	-	x	x
255	0	End of General Interrogation	-	8	10	-	x	x

Table Showing Command Information (INF) Numbers

FUN	INF	Description	COM	TYP	COT		AG 1	AG 2 - 500
160	16	Auto-recloser ON/OFF	ON/OFF	20	20		-	-
160	19	Reset Flag & Outputs	ON	20	20		x	x

FUN	INF	Description	COM	TYP	COT		AG 1	AG 2 - 500
160	23	Settings Group 1 Select	ON	20	20		x	x
160	24	Settings Group 2 Select	ON	20	20		x	x
160	25	Settings Group 3 Select	ON	20	20		x	x
160	26	Settings Group 4 Select	ON	20	20		x	x
164	35	Settings Group 5 Select	ON	20	20		x	x
164	36	Settings Group 6 Select	ON	20	20		x	x
164	37	Settings Group 7 Select	ON	20	20		x	x
164	38	Settings Group 8 Select	ON	20	20		x	x
164	51	Energise Output 1	ON	20	20		x	x
164	52	Energise Output 2	ON	20	20		x	x
164	53	Energise Output 3	ON	20	20		x	x
164	54	Energise Output 4	ON	20	20		x	x
164	55	Energise Output 5	ON	20	20		x	x
164	56	Energise Output 6	ON	20	20		x	x
164	57	Energise Output 7	ON	20	20		x	x
164	58	Energise Output 8	ON	20	20		x	x
164	59	Energise Output 9	ON	20	20		x	x
164	60	Energise Output 10	ON	20	20		x	x
164	61	Energise Output 11	ON	20	20		x	x
164	80	Trigger Waveform Storage	ON	20	20		x	x
164	82	Trip and Lockout	ON	20	20			
164	83	Close and Reclaim	ON	20	20			
164	84	Trip And Reclose	ON	20	20			
164	86	Close And Lockin	ON/OFF	20	20			
164	100	Cold load pickup	ON/OFF	20	20			
164	110	SEF	ON/OFF	20	20			
164	112	P/F ARC Inhibit	ON/OFF	20	20			
164	113	E/F ARC Inhibit	ON/OFF	20	20			
164	114	SEF ARC Inhibit	ON/OFF	20	20			
164	115	Instantaneous	ON/OFF	20	20			
164	116	P/F Instantaneous	ON/OFF	20	20			
164	117	E/F Instantaneous	ON/OFF	20	20			

FUN	INF	Description	COM	TYP	COT		AG 1	AG 2 - 500
164	118	SEF Instantaneous	ON/OFF	20	20			
164	119	Hot line working	ON/OFF	20	20			
164	129	Reset Energy Meters	ON/OFF	20	20			x
164	130	Reset Maximum Demand	ON/OFF	20	20		x	x
255	0	Initiate General Interrogation	-	7	9	-	x	x
255	0	Time Synchronisation	-	6	8		x	x

Note: Events listing a GI cause of transmission can be raised and cleared; other events are raised only.

## 3.2 Modbus RTU Definitions

The following tables give information on the IEC 60870-5-103 protocol. A detailed description of all protocol information is available in report no 434/TM/5/13 which can be accessed on the [www.reyrolle-protection.com](http://www.reyrolle-protection.com) in publications section under technical reports, "communications interface manual".

The tables below detail the MODBUS address map, listing data points that are available and the functions supported for access. **Please note, not all addresses will apply to all models.**

To configure MODBUS a new setting has been added to the communications sub-menu to select the protocol to use, either IEC60870-5-103 or MODBUS-RTU. After selecting MODBUS, set the remaining parameters, baud rate, parity, station (slave) address, line idle and data echo as appropriate.

When an electrical RS485 module is connected to the Argus relay, the **Line Idle** and **Data Echo** settings must both be set to **OFF**.

**Table showing Coil Addresses**

MODBUS Address	IEC FUN	IEC INF	Description	COM	AG 2	AG 2-5XX
00016	160	16	Autoreclose	ON/OFF		
00019	160	19	Reset Flag & Outputs *	ON	x	x
00023	160	23	Settings Group 1 Select	ON	x	x
00024	160	24	Settings Group 2 Select	ON	x	x
00025	160	25	Settings Group 3 Select	ON	x	x
00026	160	26	Settings Group 4 Select	ON	x	x
01059	164	35	Settings Group 5 Select	ON	x	x
01060	164	36	Settings Group 6 Select	ON	x	x
01061	164	37	Settings Group 7 Select	ON	x	x
01062	164	38	Settings Group 8 Select	ON	x	x
01075	164	51	Energise Output 1	ON	x	x
01076	164	52	Energise Output 2	ON	x	x
01077	164	53	Energise Output 3	ON	x	x

MODBUS Address	IEC FUN	IEC INF	Description	COM	AG 2	AG 2-5XX
01078	164	54	Energise Output 4	ON	x	x
01079	164	55	Energise Output 5	ON	x	x
01080	164	56	Energise Output 6	ON	x	x
01081	164	57	Energise Output 7	ON	x	x
01082	164	58	Energise Output 8	ON	x	x
01083	164	59	Energise Output 9	ON	x	x
01084	164	60	Energise Output 10	ON	x	x
01085	164	61	Energise Output 11	ON	x	x
01104	164	80	Trigger Waveform Storage *	ON	x	x
01106	164	82	Trip and Lockout*	ON		
01107	164	83	Close and Reclaim*	ON		
01108	164	84	Trip and Reclose*	ON		
01110	164	86	Close and Lockin*	ON/OFF		
01124	164	100	Cold Load Pickup	ON/OFF		
01134	164	110	SEF	ON/OFF		
01136	164	112	PF ARC Inhibit	ON/OFF		
01137	164	113	EF ARC Inhibit	ON/OFF		
01138	164	114	SEF ARC Inhibit	ON/OFF		
01139	164	115	Instantaneous	ON/OFF		
01140	164	116	P/F Instantaneous	ON/OFF		
01141	164	117	E/F Instantaneous	ON/OFF		
01142	164	118	SEF Instantaneous	ON/OFF		
01143	164	119	Hot Line Working	ON/OFF		
01154	164	130	Reset Maximum Demand *	ON	x	x

Table Showing Inputs

MODBUS Address	FUN	INF	Description	AG 1 & 2	AG 2-5XX
10016	160	16	Auto Reclose Active		
10021	160	21	Trip Test	x	x
10022	160	22	Settings changed	x	x
10023	160	23	Setting G1 selected	x	x
10024	160	24	Setting G2 selected	x	x
10025	160	25	Setting G3 selected	x	x
10026	160	26	Setting G4 selected	x	x
10027	160	27	Input 1	x	x
10028	160	28	Input 2	x	x



<b>MODBUS Address</b>	<b>FUN</b>	<b>INF</b>	<b>Description</b>	<b>AG 1 &amp; 2</b>	<b>AG 2-5XX</b>
10029	160	29	Input 3	x	x
10030	160	30	Input 4	x	x
10036	160	36	Trip circuit fail	x	x
10046	160	46	Group Warning		
10047	160	47	Alarm		
10064	160	64	A-starter	x	x
10065	160	65	B-starter	x	x
10066	160	66	C-starter	x	x
10067	160	67	E-starter	x	x
10084	160	84	General starter	x	x
10128	160	128	CB on by auto recluse		
10130	160	130	Reclose blocked		
11045	164	21	SEF/REF starter	x	x
11058	164	34	Circuit breaker open		
11059	164	35	Setting G5 selected	x	x
11060	164	36	Setting G6 selected	x	x
11061	164	37	Setting G7 selected	x	x
11062	164	38	Setting G8 selected	x	x
11065	164	41	CB close fail		
11067	164	43	CB DBI state		
11069	164	45	Input 5	x	x
11070	164	46	Input 6	x	x
11071	164	47	Input 7	x	x
11072	164	48	Input 8	x	x
11073	164	49	Input 9	x	x
11075	164	51	Output1	x	x
11076	164	52	Output2	x	x
11077	164	53	Output3	x	x
11078	164	54	Output4	x	x
11079	164	55	Output5	x	x
11080	164	56	Output6	x	x
11081	164	57	Output7	x	x
11082	164	58	Output8	x	x
11083	164	59	Output9	x	x
11084	164	60	Output10	x	x
11085	164	61	Output11	x	x
11086	164	62	Forward A	x	x
11087	164	63	Reverse A	x	x
11088	164	64	Forward B	x	x

<b>MODBUS Address</b>	<b>FUN</b>	<b>INF</b>	<b>Description</b>	<b>AG 1 &amp; 2</b>	<b>AG 2-5XX</b>
11089	164	65	Reverse B	x	x
11090	164	66	Forward C	x	x
11091	164	67	Reverse C	x	x
11092	164	68	Forward E	x	x
11093	164	69	Reverse E	x	x
11094	164	70	Trip count alarm	x	x
11095	164	71	CB maintenance alarm	x	x
11096	164	72	Frequent operations exceeded		
11097	164	73	Delta Trip Counter Alarm		
11103	164	79	Voltage Block		x
11109	164	85	Circuit breaker closed		
11111	164	87	Reclose Delay		
11112	164	88	Reclaim		
11113	164	89	Lockout		
11114	164	90	Forward SEF	x	
11115	164	91	Reverse SEF	x	
11116	164	92	Power On Counter Alarm	x	x
11121	164	97	CT Failure	x	x
11124	164	100	Cold load pickup		
11127	164	103	ARC start A		
11130	164	106	External trip block		
11134	164	110	SEF off		
11135	164	111	All ARC off		
11136	164	112	P/F ARC off		
11137	164	113	E/F ARC off		
11138	164	114	SEF ARC off		
11139	164	115	All inst off		
11140	164	116	P/F inst off		
11141	164	117	E/F inst off		
11142	164	118	SEF inst off		
11143	164	119	Hot line working		
11144	164	120	Scada Control		
11145	164	121	General alarm 1	x	x
11146	164	122	General alarm 2	x	x
11147	164	123	General alarm 3	x	x
11148	164	124	General alarm 4	x	x
11149	164	125	General alarm 5	x	x
11155	164	131	Va/Vab starter		x
11156	164	132	Vb/Vbc starter		x

MODBUS Address	FUN	INF	Description	AG 1 & 2	AG 2-5XX
11157	164	133	Vc/Vca starter		x
11194	164	170	V starter		x
11214	164	190	Voltage Memory A		x
11215	164	191	Voltage Memory B		x
11216	164	192	Voltage Memory C		x

Table Showing Input Registers

MODBUS Address	Description	Size (Words)	Scaling	Units Scaled	A G2	AG 2-5XX
30001	Number Of Events In Store	1	1	-	x	x
30002	Latest Event Record	8	-	-	x	x
30101	IA (PRIMARY)	2	1000	A	x	x
30103	IB (PRIMARY)	2	1000	A	x	x
30105	IC (PRIMARY)	2	1000	A	x	x
30107	IE (PRIMARY)	2	1000	A	x	x
30109	ISEF/REF (PRIMARY)	2	1000	A	x	x
30111	Ia (SECONDARY)	2	1000	A	x	x
30113	Ib (SECONDARY)	2	1000	A	x	x
30115	Ic (SECONDARY)	2	1000	A	x	x
30117	Ie (SECONDARY)	2	1000	A	x	x
30119	Isef/ref (SECONDARY)	2	1000	A	x	x
30121	Ia (xIn)	2	1000	xIn	x	x
30123	Ib (xIn)	2	1000	xIn	x	x
30125	Ic (xIn)	2	1000	xIn	x	x
30127	Ie (xIn)	2	1000	xIn	x	x
30129	Isef/ref (xIn)	2	1000	xIn	x	x
30131	A Direction	8	-	-	x	x
30139	B Direction	8	-	-	x	x
30147	C Direction	8	-	-	x	x
30155	E Direction	8	-	-	x	x
30163	Relay Status	8	-	-	x	x
30171	Status Inputs	8	-	-	x	x
30179	Trip Circuit Fail	8	-	-	x	x
30187	Trip Counter	2	1	-	x	x
30189	Delta Trip Count	2	1	-		
30191	Frequent Operation Counter	2	1	-		
30193	Sum of I <sup>2</sup>	2	100	MA <sup>2</sup>	x	x
30195	Number of Waveforms	2	1	-	x	x
30197	Number of Events	2	1	-	x	x
30199	Number of Faults	2	1	-	x	x
30201	Time	8	-	-	x	x
30209	Date	8	-	-	x	x
30217	Starters	8	-	-	x	x
30257	General Alarms	8	-	-	x	x
30265	Power On/Resets	8	-	-	x	x

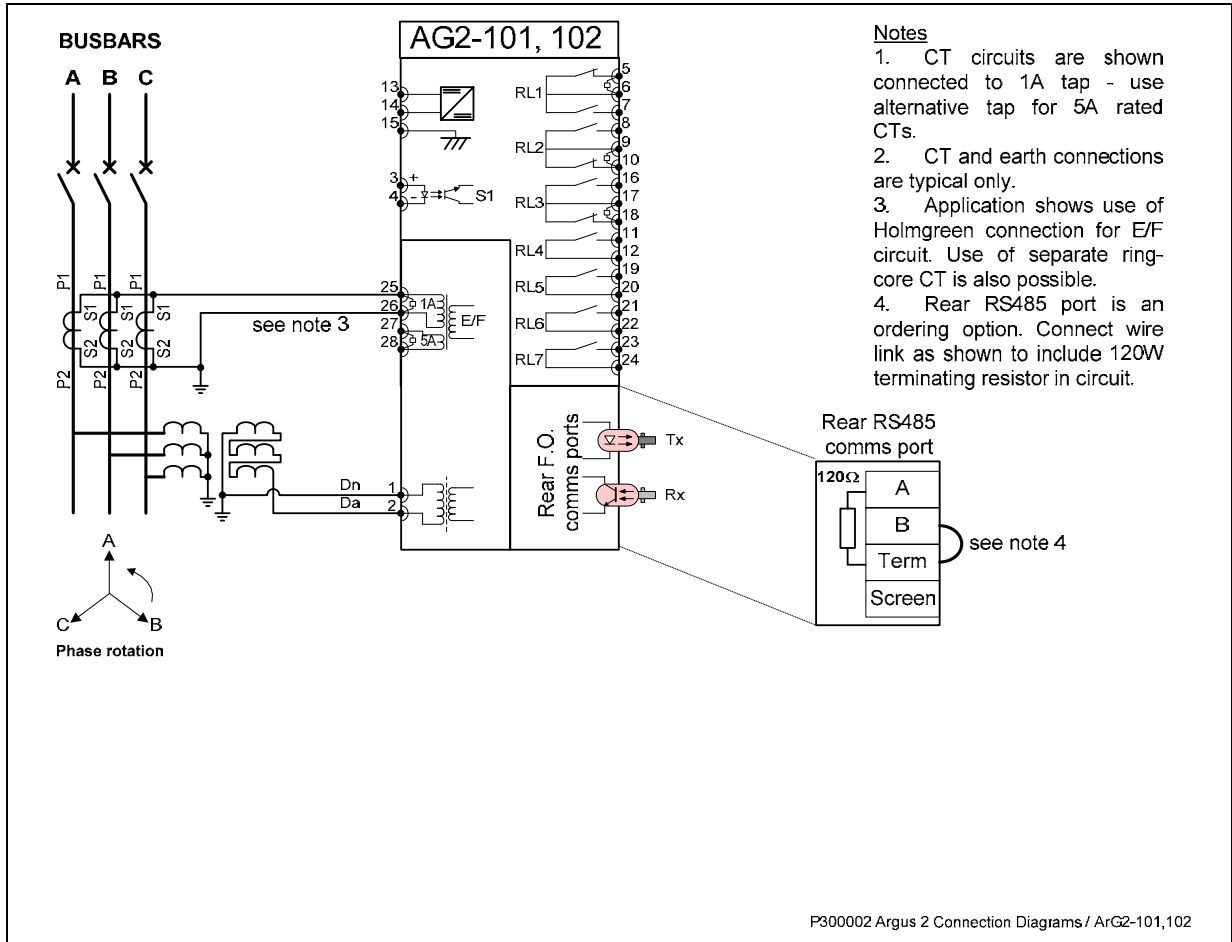
30273	ARC Status	8	-	-		
30281	ARC Inhibits	8	-	-		
30289	Circuit Breaker	8	-	-		
30297	Shot Number	2	1	-		
30299	Power On Counter	2	1	-	x	x
30301	VA (PRIMARY)	2	1000	V		x
30303	VB (PRIMARY)	2	1000	V		x
30305	VC (PRIMARY)	2	1000	V		x
30307	VN (PRIMARY)	2	1000	V		x
30309	VAB (PRIMARY)	2	1000	V		x
30311	VBC (PRIMARY)	2	1000	V		x
30313	VCA (PRIMARY)	2	1000	V		x
30315	Va (SECONDARY)	2	1000	V		x
30317	Vb (SECONDARY)	2	1000	V		x
30319	Vc (SECONDARY)	2	1000	V		x
30321	Vn (SECONDARY)	2	1000	V		x
30323	Vab (SECONDARY)	2	1000	V		x
30325	Vbc (SECONDARY)	2	1000	V		x
30327	Vca (SECONDARY)	2	1000	V		x
30329	3Phase Power	2	1	kW		x
30331	3Phase Apparent Power	2	1	kVA		x
30333	3Phase Reactive Power	2	1	kVAr		x
30335	3Phase Power Factor	8	-	-		x
30343	Voltage Element	8	-	-		x
30393	WHr (Forward)	2	1	kWHr		x
30395	WHr (Reverse)	2	1	kWHr		x
30397	VArHr (Forward)	2	1	kVArHr		x
30399	VArHr (Reverse)	2	1	kVArHr		x
30401	IA (PRIMARY) Demand	2	1000	A	x	x
30403	IB (PRIMARY) Demand	2	1000	A	x	x
30405	IC (PRIMARY) Demand	2	1000	A	x	x
30407	IA (PRIMARY) Max Demand	2	1000	A	x	x
30409	IB (PRIMARY) Max Demand	2	1000	A	x	x
30411	IC (PRIMARY) Max Demand	2	1000	A	x	x
30413	3Phase Watt Demand	2	1	kW		x
30415	3Phase VAr Demand	2	1	kVAr		x
30417	3Phase Watt Max Demand	2	1	kW		x
30419	3Phase VAr Max Demand	2	1	kVAr		x

**Table Showing Holding Registers**

Address	Description		FORMAT	SIZE (WORDS)	AG 1 & 2	AG 2-5XX
40001	Set Time		Time 8	4	x	x

## Section 4: Application Diagrams

The following pages contain example application diagrams for a variety of connections, showing various hardware options.



**Figure 4-1 Typical Connection for Directional Earth-fault Protection**

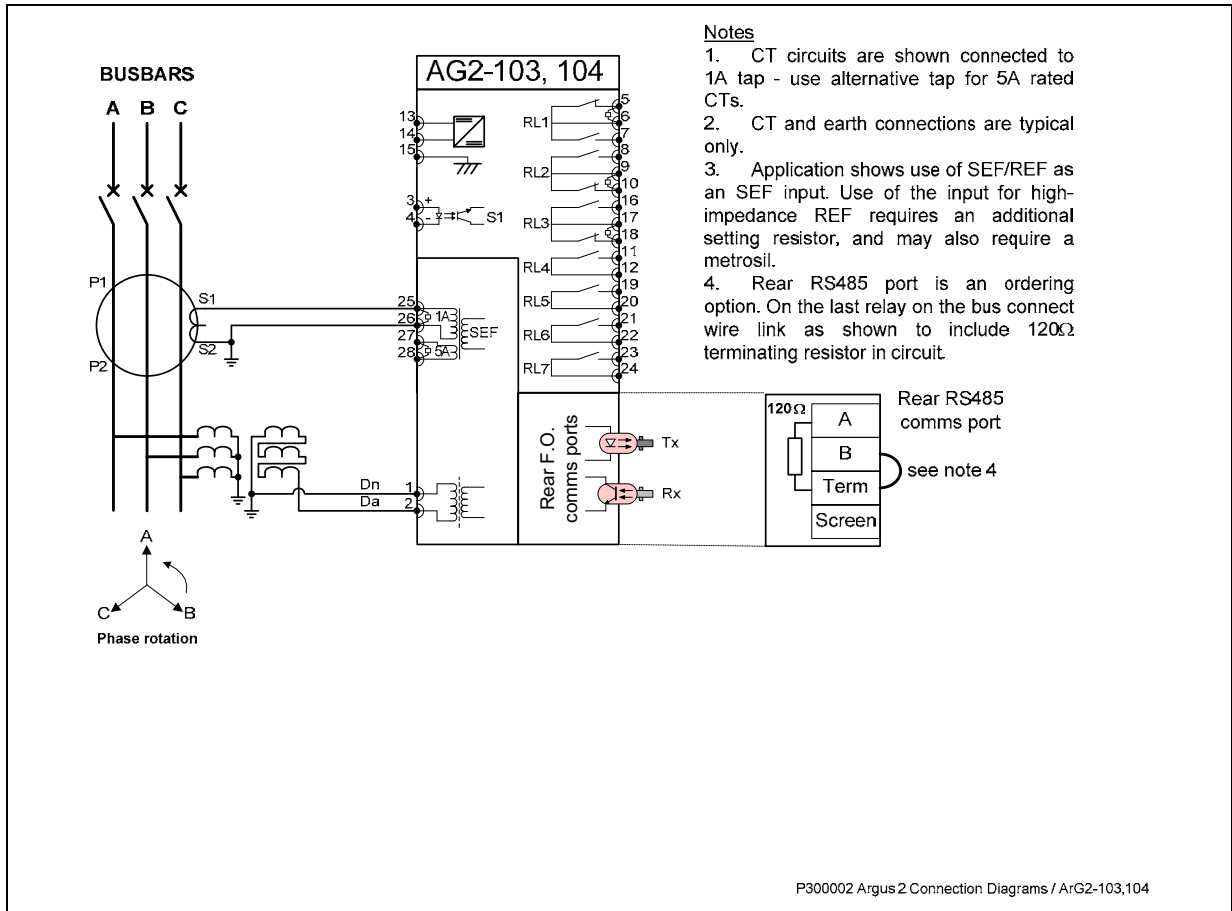


Figure 4-2 Typical Connection for Directional Sensitive Earth-fault Protection

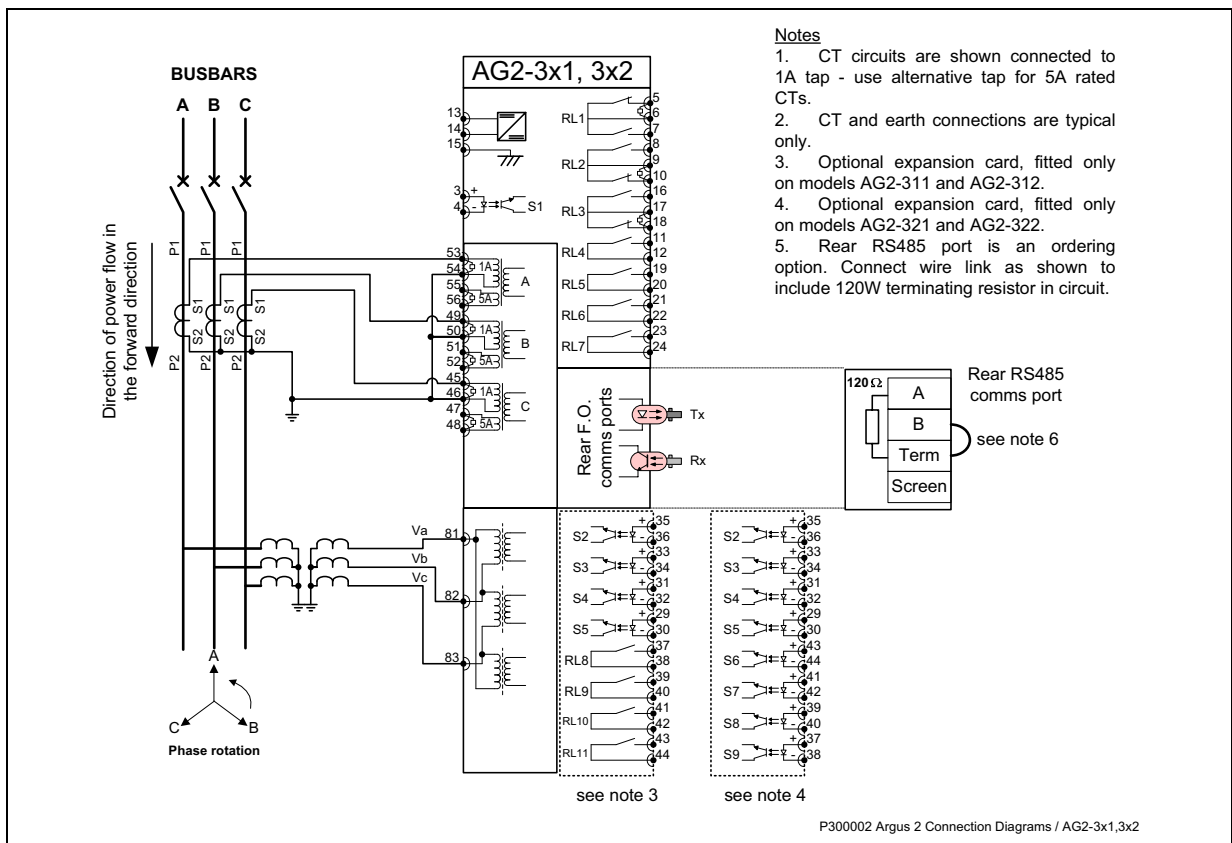
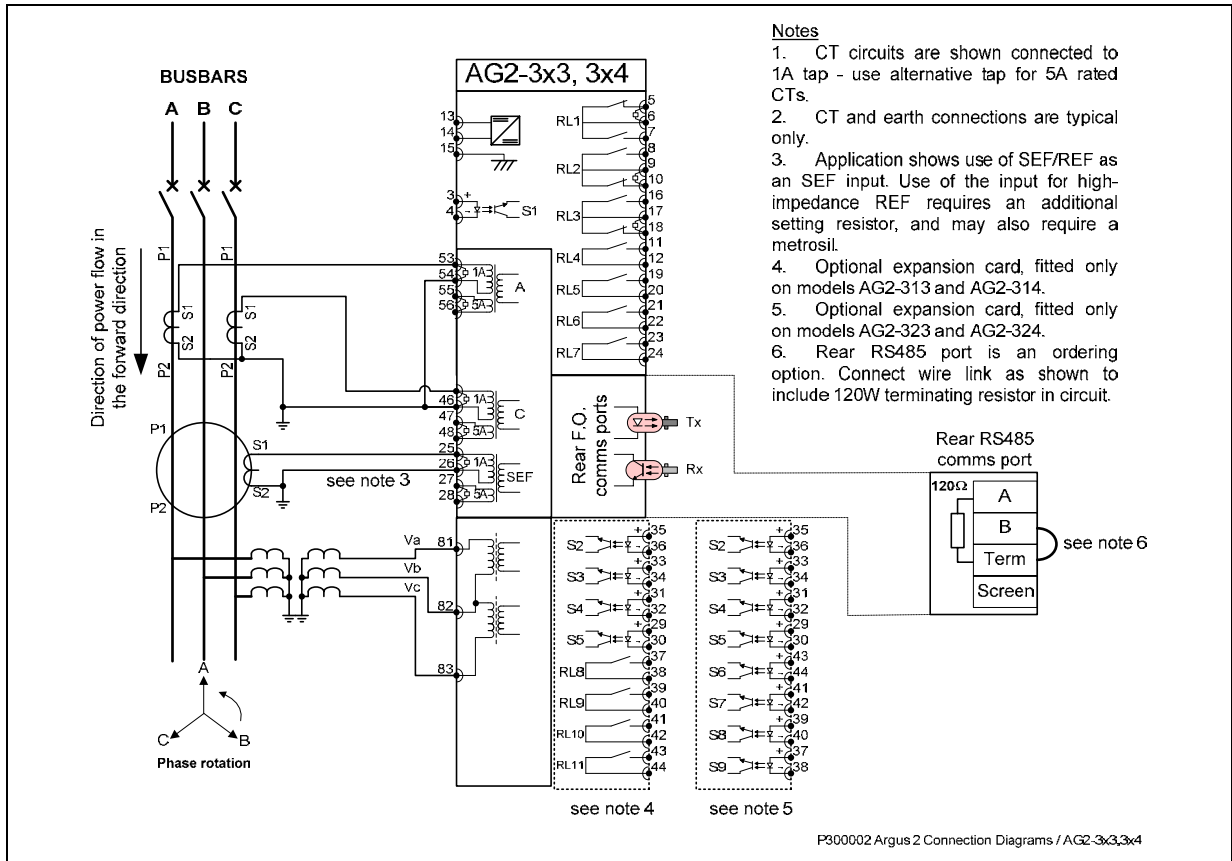
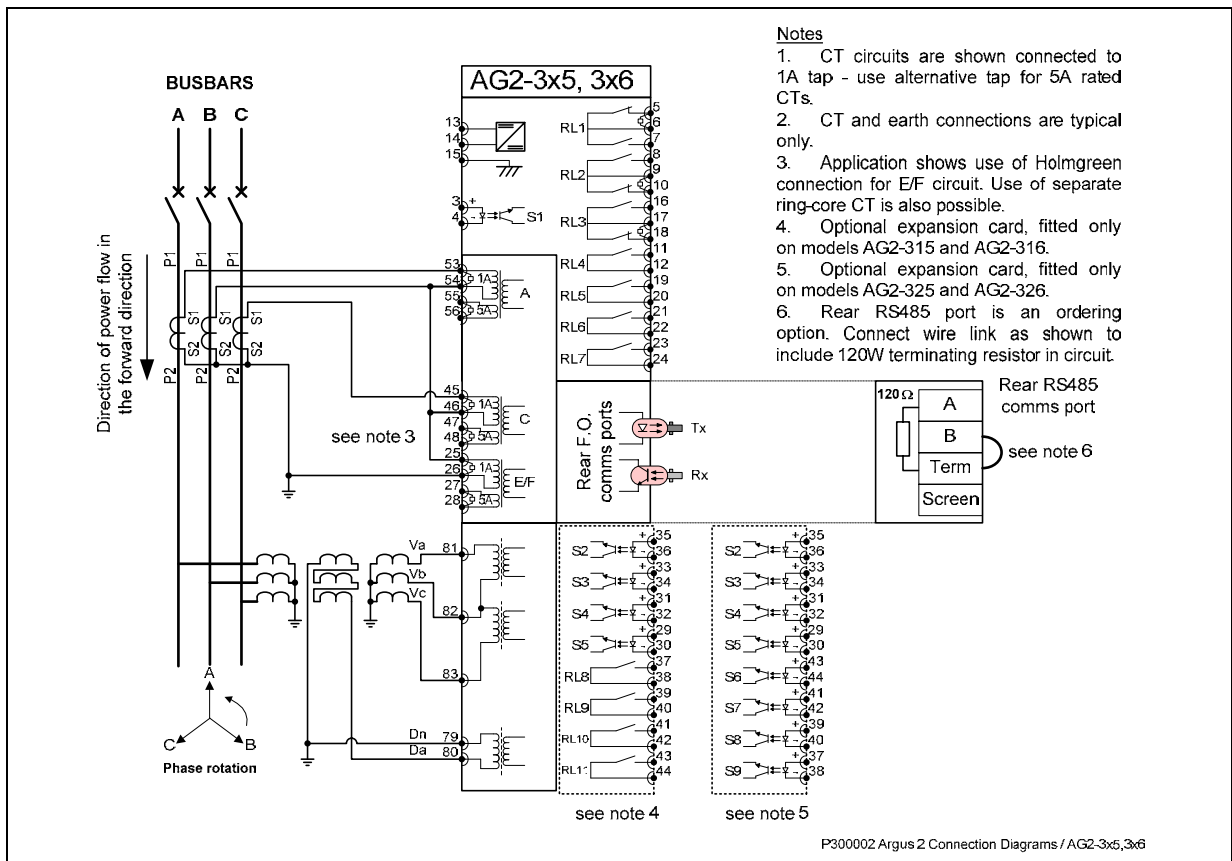


Figure 4-3 Typical Connection for 3 Directional Phase-fault Protection



**Figure 4-4 Typical Connection for 2 Directional Phase-fault and Sensitive Earth-fault Protection**



**Figure 4-5 Typical Connection for 2 Directional P/F and Directional E/F Protection**

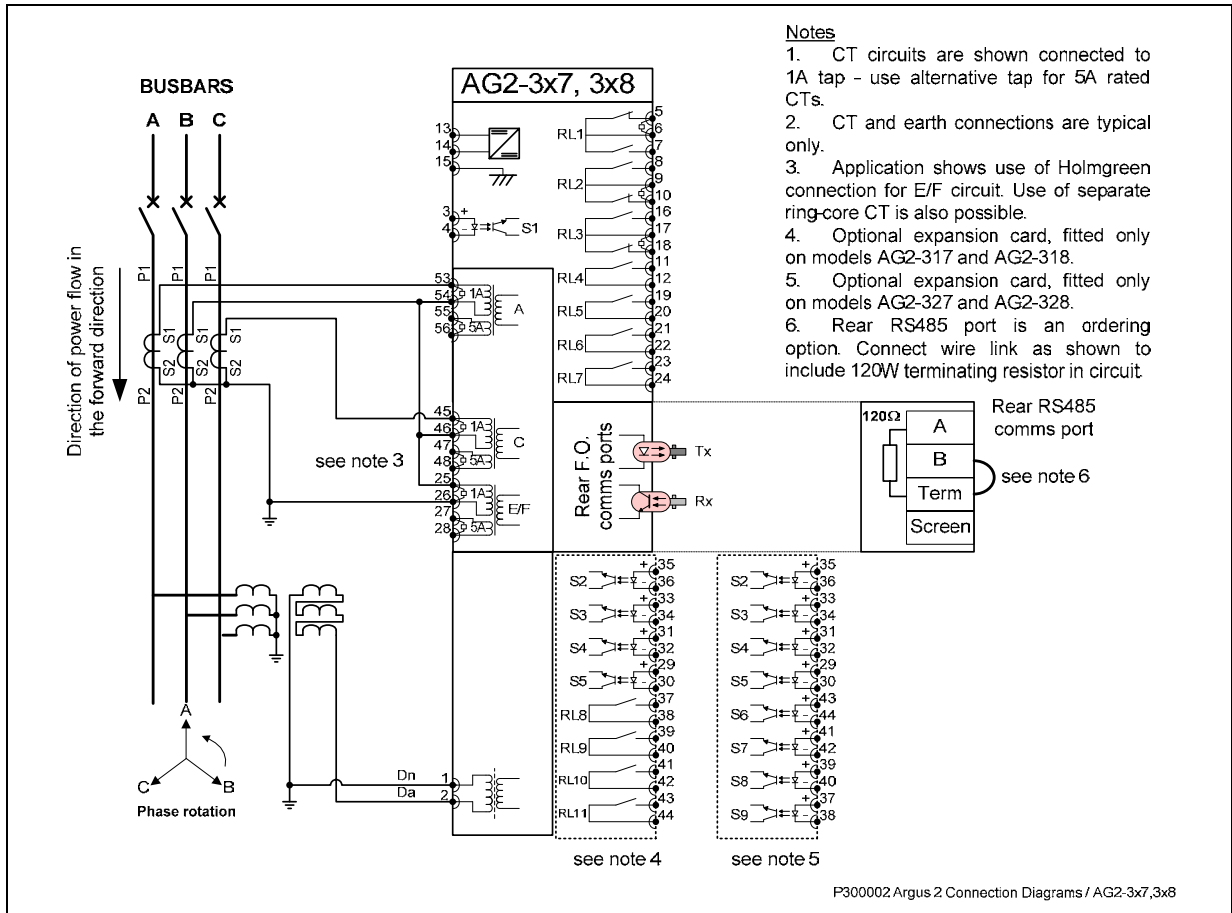


Figure 4-6 Typical Connection for 2 Phase-fault and Directional Earth-fault Protection

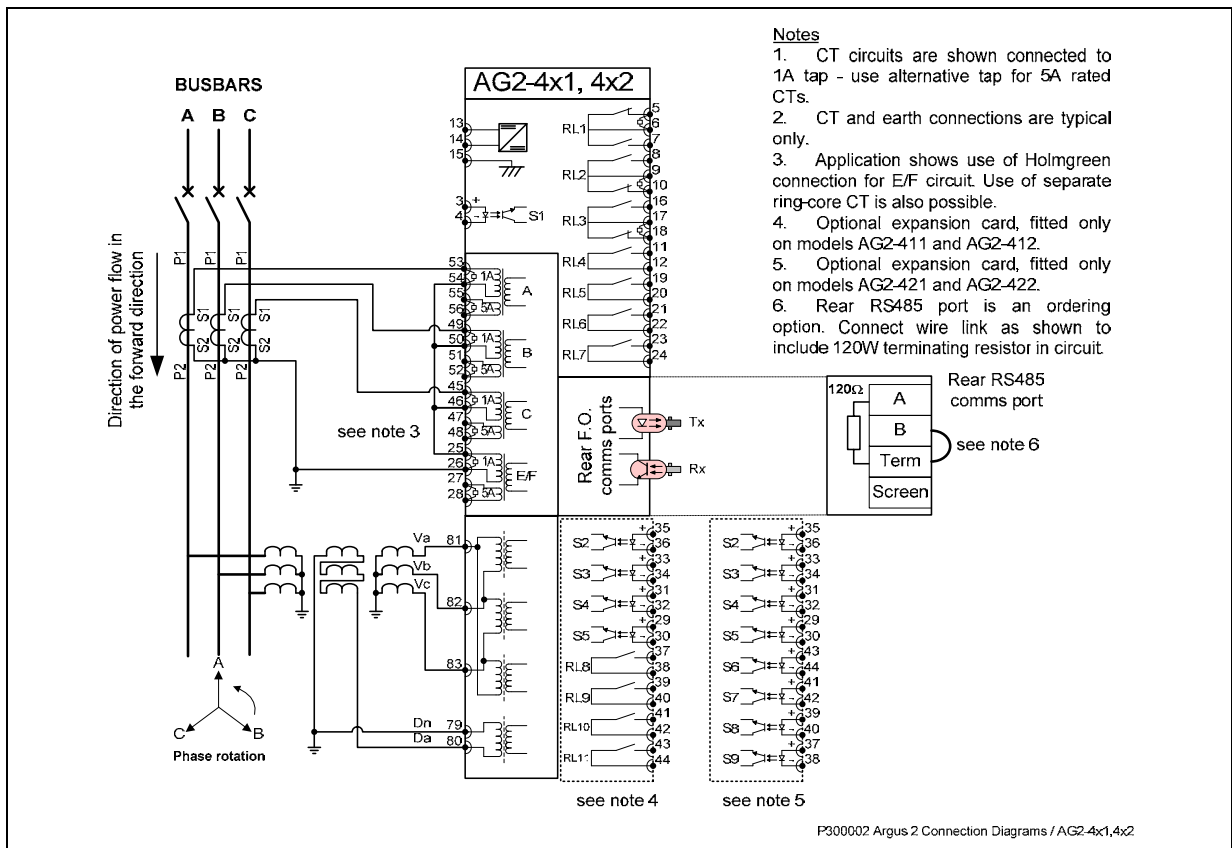
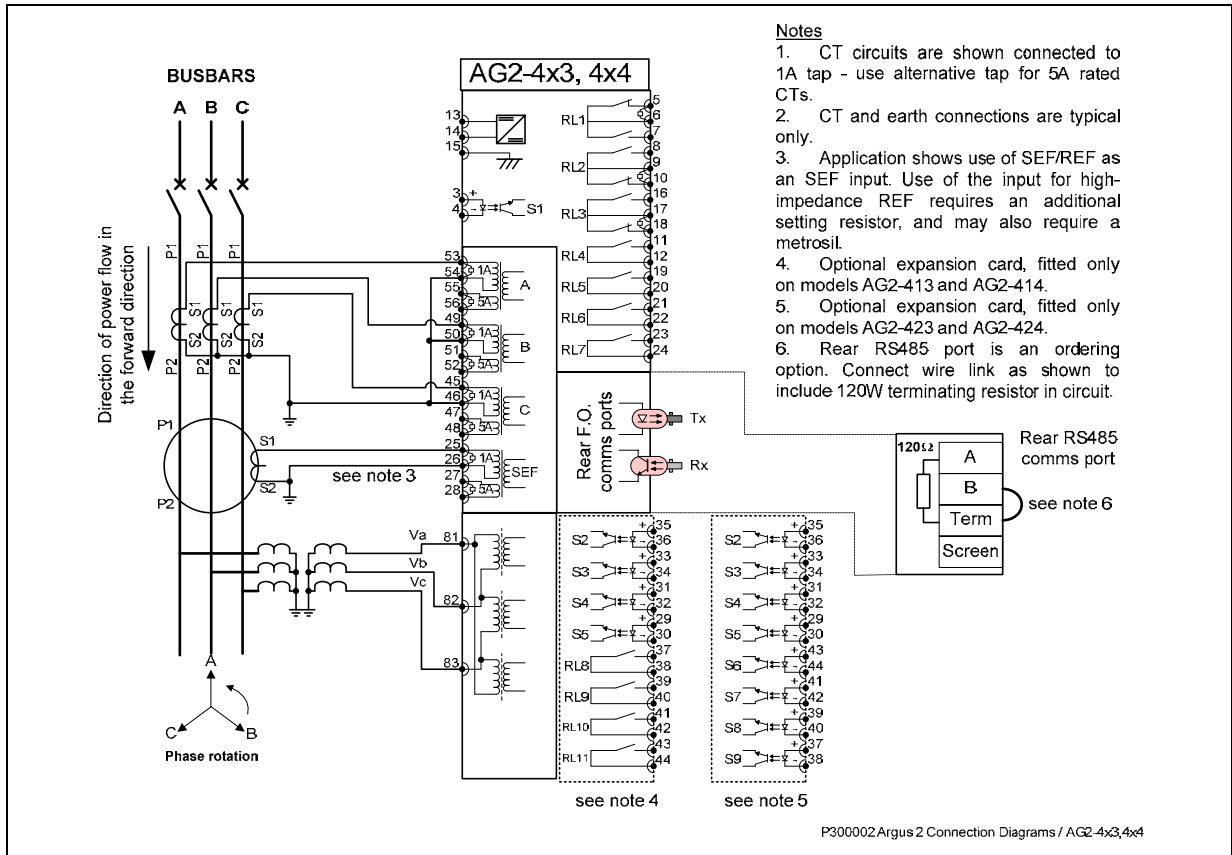
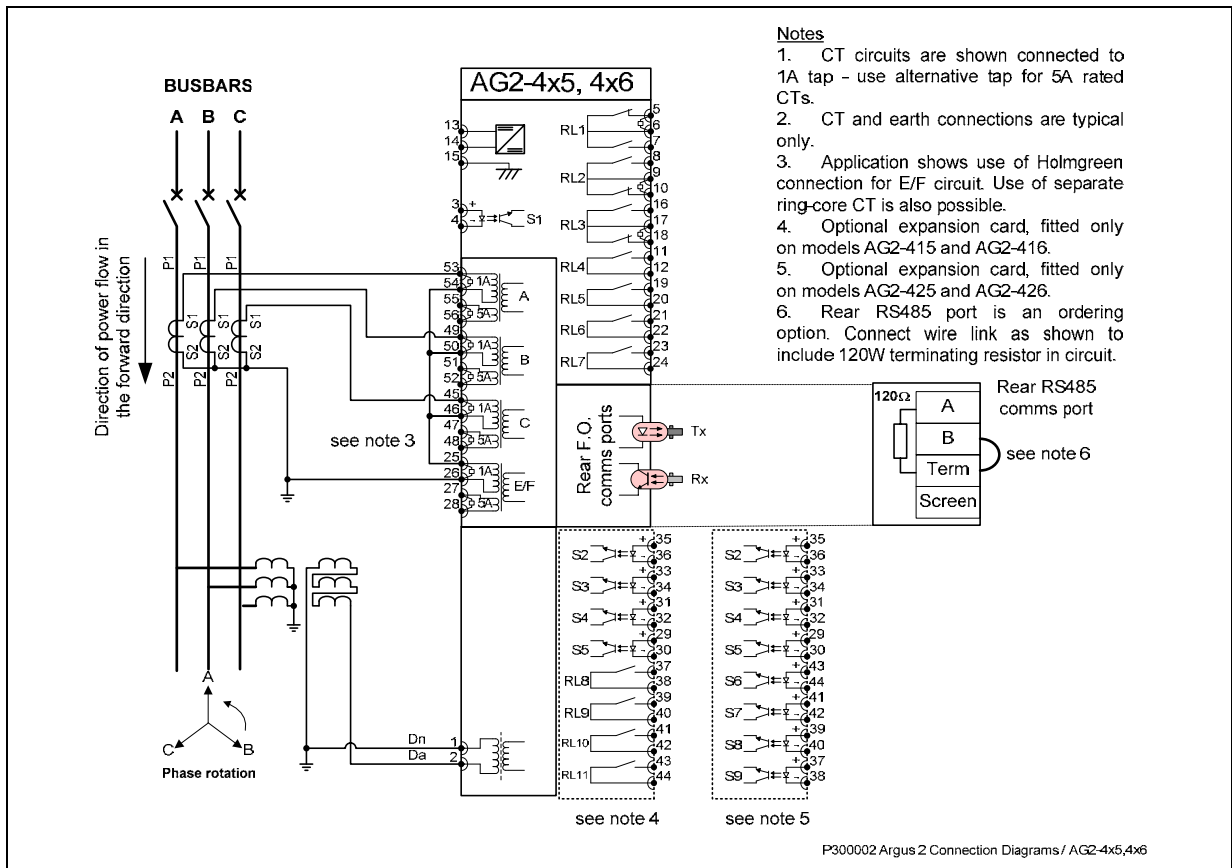


Figure 4-7 Typical Connection for 3 Directional P/F and Directional E/F Protection





**Figure 4-8 Typical Connection for 3 Directional Phase-fault and Sensitive Earth-fault Protection**



**Figure 4-9 Typical Connection for 3 Phase-fault and Directional Earth-fault Protection**

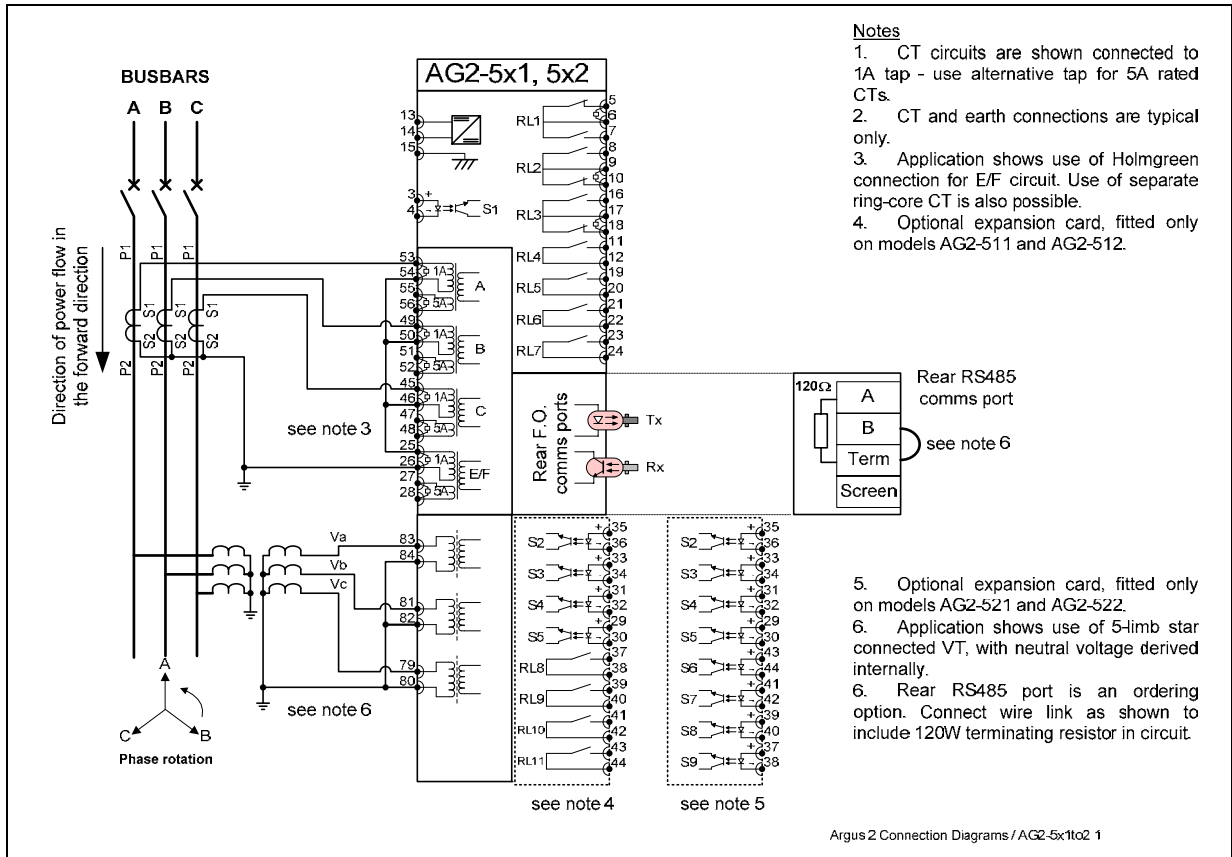


Figure 4-10 Typical Connection of Type AG2-5xx Dir P/F and Dir E/F with Star-connected VT

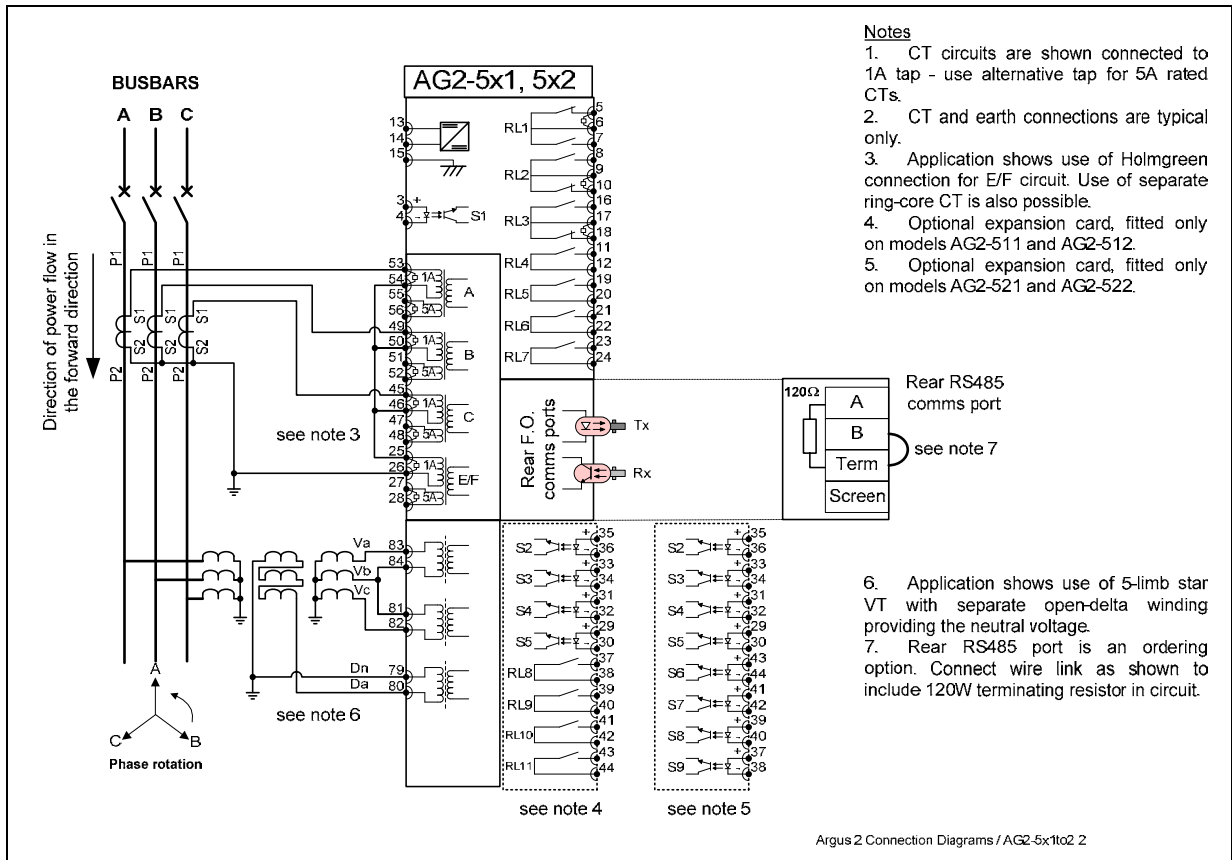


Figure 4-11 Typical Connection of Type AG2-5xx Dir P/F and Dir E/F with Open-delta VT

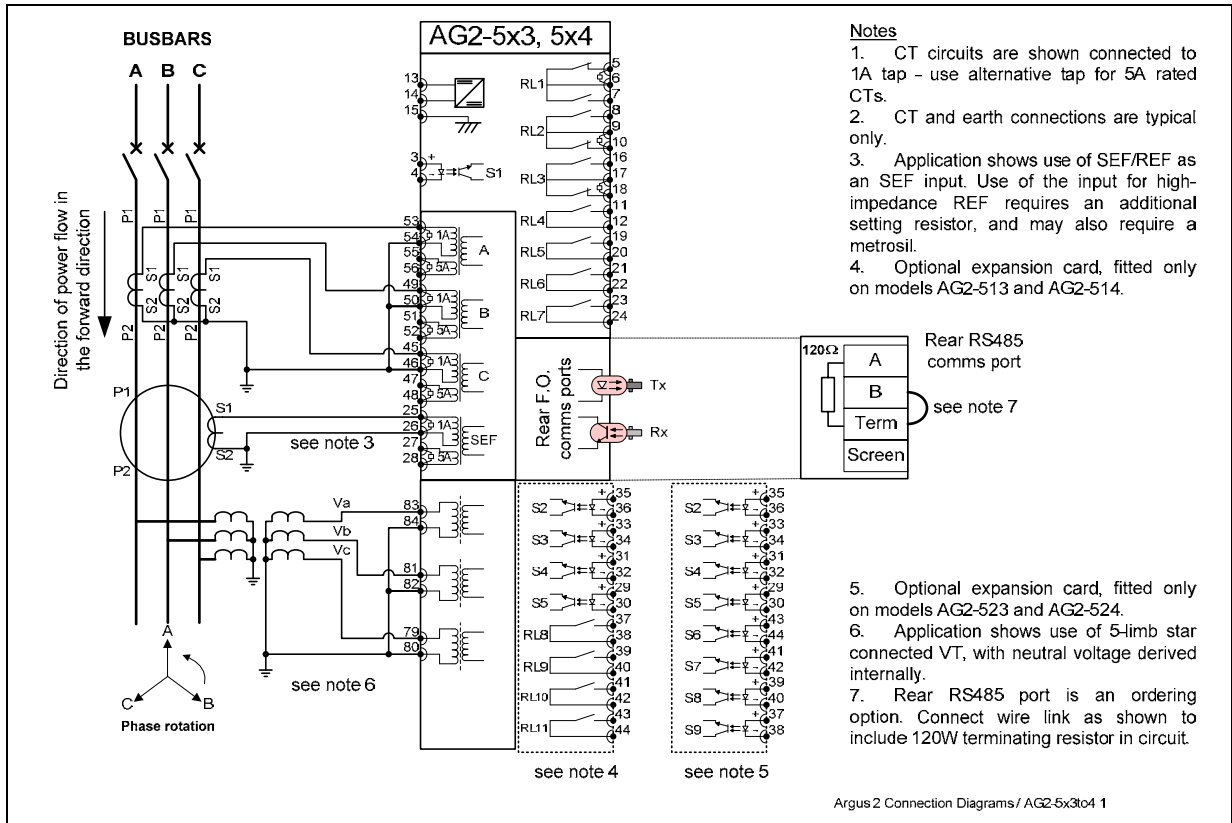


Figure 4-12 Typical Connection of Type AG2-5xx Dir P/F and SEF with Star-connected VT

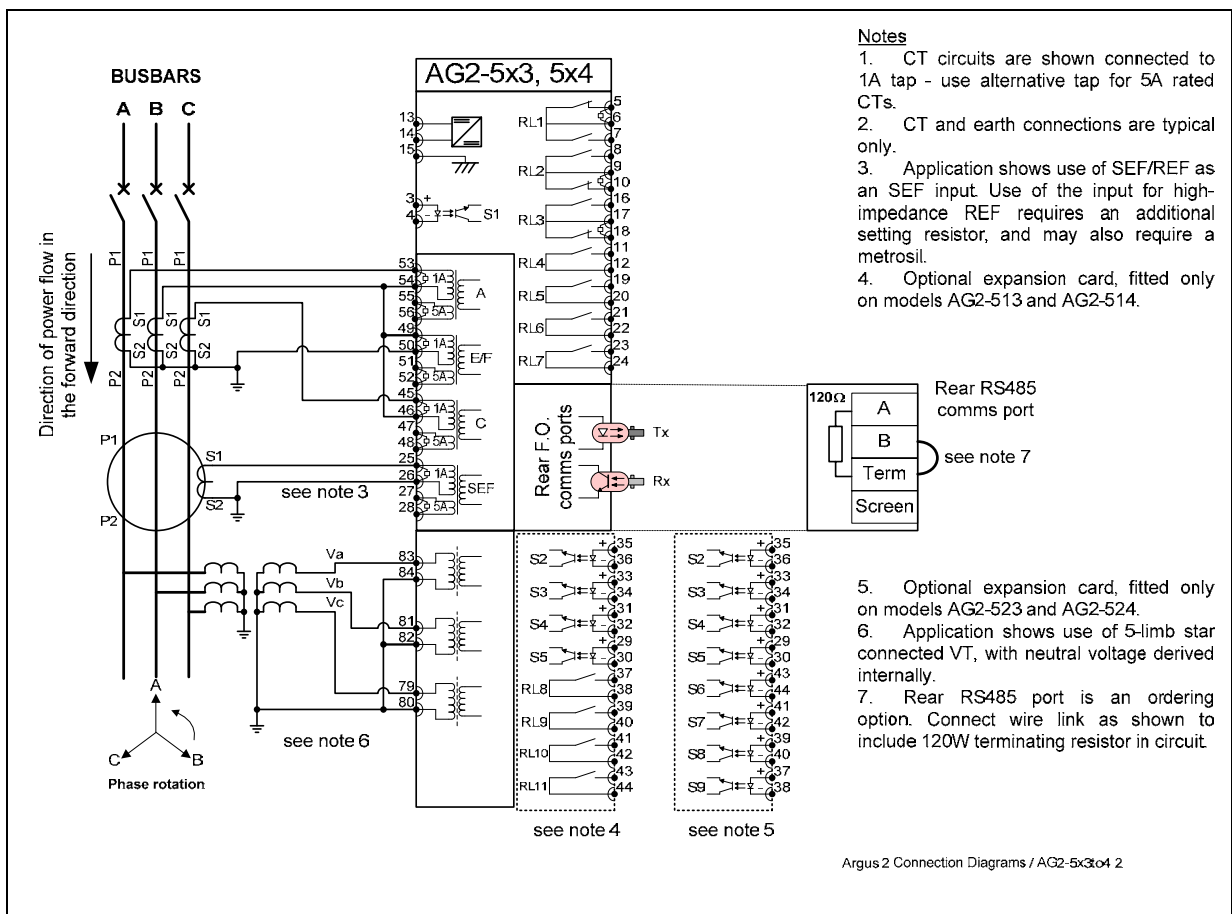
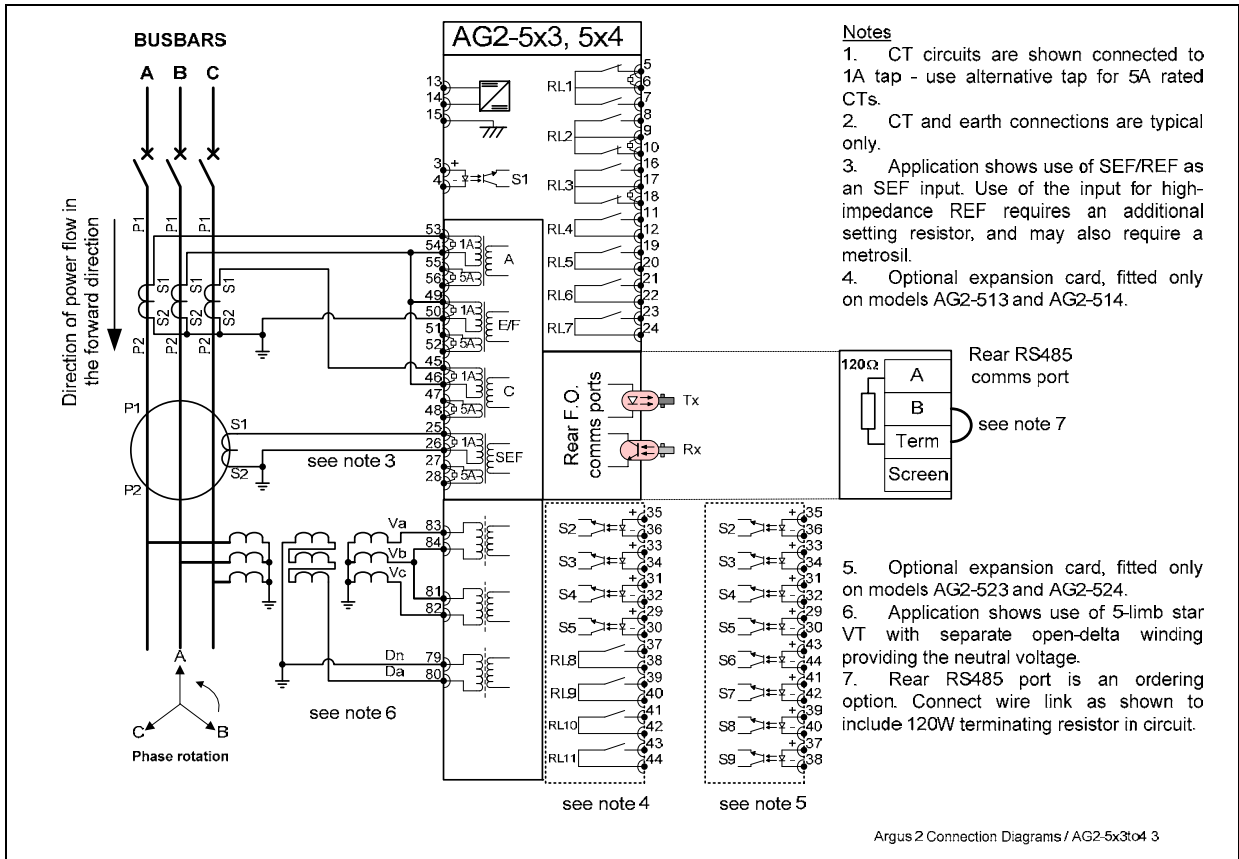


Figure 4-13 Typical Connection of Type AG2-5xx Dir P/F Dir E/F and SEF with Star-connected VT



**Figure 4-14** Typical Connection of Type AG2-5xx Dir P/F, Dir E/F and SEF with Open-delta VT

# 7SG11Argus

Overcurrent Protection Relays

## Document Release History

This document is issue 2010/02 The list of revisions up to and including this issue is:

Pre release

2010/02	Document reformat due to rebrand
2005/06	Third issue: Editorial modifications, software revision histories updated
2004/07	Second issue. Power On alarm added
2002/12	First issue

The copyright and other intellectual property rights in this document, and in any model or article produced from it (and including any registered or unregistered design rights) are the property of Siemens Protection Devices Limited. No part of this document shall be reproduced or modified or stored in another form, in any data retrieval system, without the permission of Siemens Protection Devices Limited, nor shall any model or article be reproduced from this document unless Siemens Protection Devices Limited consent.

While the information and guidance given in this document is believed to be correct, no liability shall be accepted for any loss or damage caused by any error or omission, whether such error or omission is the result of negligence or any other cause. Any and all such liability is disclaimed.

## Software Release History

The software listed below is used in one of more types Argus relay. The list of software revisions applying to Argus 4, up to and including this document issue is:

Mar 2005	2716H80005 R5	Mods to reclose blocked Mod to "Checking Settings" screen at switch on
Jul 2003	2716H80005 R3	Function added: Status input Inversion Minor change: Latched input 8/9 display corrected
Mar 2003	2716H80005 R2	Function added: Power On count alarm Minor change: IEC 870-5-103 Time Sync optimised Minor change: communications with ReyDisp Minor change: Trip & Reclose action when no CB - corrected
Feb 2002	2716H80005R1	Function added: trip count alarm display added Function added: setting added to hide/show linesman mode display Function added: close and reclaim command split in two – one for local (delayed) and one for remote (no delay) Minor change: fault display shows lockout due to hot line working Minor change: communications – general command blocking Minor change: trip count – non-fault trips and alarm action
Nov 2000	2716H80004 R1/2	Internal Evaluation code - version not released
Sep 1999	2716H80003 R2	Minor change: on-screen alarm display Minor change: frequent operation counter reset Minor change: trip circuit supervision alarm
Nov 1998	2716H80001 R3	First release

## Hardware Release History

The Argus hardware is used in many different relays. The list of hardware revisions applying to Argus 4, up to and including this document issue is:

Mar 2002	Appearance change: modification to grey fascia design – logo, dark grey band, buttons and label.
Jan 2002	External change: SMA fibre-optic connectors replaced by ST <sup>TM</sup> (BFOC/2.5) by default.
Jul 1999	Appearance change: introduction of grey fascia design to replace existing black fascia.
Jul 1999	External change: introduction of Epsilon case and terminal blocks
Nov 1998	First release

## Contents

<b>Software Release History .....</b>	<b>2</b>
<b>Hardware Release History .....</b>	<b>2</b>
<b>Section 1: Variants .....</b>	<b>4</b>
<b>Section 2: Settings .....</b>	<b>6</b>
<b>Section 3: IEC 60870-5-103 Definitions .....</b>	<b>13</b>
<b>Section 4: Application Diagrams .....</b>	<b>21</b>

## List of Figures

Figure 2-1	Status Input and Output Relay Programming Matrix .....	12
Figure 4-1	Typical Connection for 3 Phase-fault and Earth-fault Protection.....	21
Figure 4-2	Typical Connection for 2 Phase-fault, Earth-fault and Sensitive Earth-fault Protection .....	22
Figure 4-3	Typical Connection for 3 Phase-fault and Sensitive Earth-fault Protection .....	22

## Section 1: Variants

This document applies to the Argus relays listed in the following MLFB Structure & table.

The MLFB Structure references the complete number for each relay:

- 7SG11nn-nxxnn-nxA0

where n is a digit and x is a letter.

The table uses two references for most relays, each of which is valid:

- an 'Order code' of the form AGn-nnn, and
- a 'Type' of the form GAFnnnX

where n is a digit and X is a letter.

Protection	Application Diagram	I/O	Order code / Type				
			30/48 aux. 30V status	48V status	48V status	110/220 aux. 110V status 220V status	
3 phase-fault and earth-fault	Fig. 4-1	$\frac{9}{7}$ SI OR	GAF431C	<b>AG4-401</b> GAF433C	<b>AG1-402</b> GAF434C		
3 phase-fault and SEF/REF, or 2 phase-fault, earth-fault and SEF/REF	Fig. 4-3 Fig. 4-2	$\frac{9}{7}$ SI OR	GAF441C	<b>AG4-403</b> GAF443C	<b>AG4-404</b> GAF444C	GAF445C	



## Ordering Information – 7SG114 Argus 4

Product description	Variants	Order No.
<p>Nondirectional O/C Relay with autoreclose</p> <p>Integrated overcurrent and earth fault relay with multishot autoreclose facilities.</p> <p><u>Number of elements</u> Four pole relay</p> <p><u>Auxiliary supply /binary input voltage</u> 24/30/48 V DC auxiliary, 30 V binary input 110/220 V DC auxiliary, 30 V binary input 24/30/48 V DC auxiliary, 48 V binary input 110/220 V DC auxiliary, 48 V binary input <sup>1)</sup> 110/220 V DC auxiliary, 110 V low burden binary input 110/220 V DC auxiliary, 220 V low burden binary input</p> <p><u>Type of elements</u> 3 pole phase-fault and earth-fault 3 pole phase-fault and sensitive/restricted earth-fault (SEF/REF) or 2 pole phase-fault and earth fault and sensitive/restricted earth-fault (SEF/REF)</p> <p><u>Nominal current</u> 1/ 5 A</p> <p><u>I/O range</u> 9 Binary Inputs / 7 Binary Outputs (incl. 3 changeover)</p> <p><u>Communication interface</u> Fibre optic (ST-connector) / IEC 60870-5-103 or Modbus RTU RS485 interface / IEC 60870-5-103 or Modbus RTU</p> <p><u>Housing size</u> Case size E6 (4U high)</p>	<p>7 S G 1 1 4 □</p> <p>↑</p> <p>4</p> <p>□ □ □ □</p> <p>↑ ↑ ↑ ↑</p> <p>0 1 2 3 4 5</p> <p>E F</p> <p>A</p> <p>2</p> <p>1 2</p> <p>D</p>	<p>0 □ A 0</p> <p>↑</p>

## Section 2: Settings

Relay Type \_\_\_\_\_

Serial Number \_\_\_\_\_

Substation \_\_\_\_\_

Feeder Identity \_\_\_\_\_

### Notes on Tables

All settings found in the Argus 4 relay types are listed below. Within the list some settings (indicated with greyed cells) are not always visible, for the following reasons:

- Depending on the version of the relay, a particular function and hence its related settings may not be present, e.g. on a 2 phase-fault and SEF relay any settings related to earth-fault will not be present.
- Depending on the value of some settings, other settings will be hidden, e.g. if the main characteristic is set to DTL, rather than an IDMT characteristic, the time multiplier setting will be hidden and replaced by a time delay setting.

Some settings in the tables show text in square brackets, e.g. '[SEF/REF] Current Setting'. This indicates different text that may be displayed, depending on the value of other settings, i.e. 'SEF Current Setting' or 'REF Current Setting' dependent on the value of the 'Earth Fault Mode Select' setting.

The second column in the tables ('Ref') provides a reference to the section in the Technical Reference (publication P20007 issue 2002/12) that describes the setting.

The third column is left blank to allow users to complete the table with applied settings.

### System Config. Menu

Setting name	Ref	Applied value
Active Settings Group	2.2.1	
Settings Group Edit/View	2.2.1	
Cold Load Pickup Group	2.6	
Copy Group	2.2.1	
Power System Frequency	2.2.2	Hz
Set Pole B Type	2.2.3	
Earth Fault Mode Select	2.2.3	
P/F Rating (In)	2.2.3	A
E/F Rating (In)	2.2.3	A
SEF/REF Rating (In)	2.2.3	A
P/F CT Ratio	2.2.3	
E/F CT Ratio	2.2.3	
SEF/REF CT Ratio	2.2.3	
Current Display	2.2.3	
Set Identifier	2.2.4	
SET Alarm 1	2.2.5	
SET Alarm 2	2.2.5	

Setting name	Ref	Applied value
SET Alarm 3	2.2.5	
SET Alarm 4	2.2.5	
SET Alarm 5	2.2.5	
Calendar – Set Date	2.2.7	
Clock - Set Time	2.2.7	
Clock Sync. From Status	2.2.7	
Default Screen Time	2.2.8	
Change Password	2.2.9	
Linesman Display	2.15	

**Protection Menu**

Setting name	Ref	Applied value
Gn P/F Charact. Setting	2.3.1	xin
Gn P/F Charact.	2.3.1	
Gn P/F Charact. Time Mult	2.3.1	
Gn P/F Charact. Delay	2.3.1	sec
Gn P/F Lowset Setting	2.3.2	xln
Gn P/F Lowset Delay	2.3.2	sec
Gn P/F Highset1 Setting	2.3.2	xln
Gn P/F Highset1 Delay	2.3.2	sec
Gn P/F Highset2 Setting	2.3.2	xln
Gn P/F Highset2 Delay	2.3.2	sec
Gn E/F Charact. Setting	2.3.1	xin
Gn E/F Charact.	2.3.1	
Gn E/F Charact. Time Mult	2.3.1	
Gn E/F Charact. Delay	2.3.1	sec
Gn E/F Lowset Setting	2.3.2	xln
Gn E/F Lowset Delay	2.3.2	sec
Gn E/F Highset1 Setting	2.3.2	xln
Gn E/F Highset1 Delay	2.3.2	sec
Gn E/F Highset2 Setting	2.3.2	xln
Gn E/F Highset2 Delay	2.3.2	sec
Gn [SEF/REF] Current Setting	2.4	
Gn [SEF/REF] 1st Time Delay	2.4	sec
Gn [SEF/REF] 2nd Time Delay	2.4	sec
Gn [SEF/REF] Lowset Delay	2.4	sec
Gn CB Fail Time Delay1	2.5	sec
Gn CB Fail Time Delay2	2.5	sec
Gn Relay Reset Delay	2.3.3	sec
Gn Backup Alarm SA	2.9.1	sec
Gn Backup Trip SA	2.9.1	Sec

**Auto-reclose Menu**

Setting name	Ref	Applied value
Gn Line Check Trip	2.9.1	
Gn Seq Edit/View	2.9	
Gn P/F ARC	2.9.1	
Gn P/F Line Check Trip	2.9.1	
Gn P/F Protection Trip 1	2.9.1	
Gn P/F Reclose DTL 1	2.9.1	sec
Gn P/F Protection Trip 2	2.9.1	
Gn P/F Reclose DTL 2	2.9.1	sec
Gn P/F Protection Trip 3	2.9.1	
Gn P/F Reclose DTL 3	2.9.1	sec
Gn P/F Protection Trip 4	2.9.1	
Gn P/F Reclose DTL 4	2.9.1	sec
Gn P/F Shots To Lockout	2.9.1	
Gn P/F HS1 Trips to Lockout	2.9.1	
Gn P/F HS2 Trips to Lockout	2.9.1	
Gn E/F ARC	2.9.1	
Gn E/F Line Check Trip	2.9.1	
Gn E/F Protection Trip 1	2.9.1	
Gn E/F Reclose DTL 1	2.9.1	sec
Gn E/F Protection Trip 2	2.9.1	
Gn E/F Reclose DTL 2	2.9.1	sec
Gn E/F Protection Trip 3	2.9.1	
Gn E/F Reclose DTL 3	2.9.1	sec
Gn E/F Protection Trip 4	2.9.1	
Gn E/F Reclose DTL 4	2.9.1	sec
Gn E/F Shots To Lockout	2.9.1	
Gn E/F HS1 Trips to Lockout	2.9.1	
Gn E/F HS2 Trips to Lockout	2.9.1	
Gn [SEF/REF] ARC	2.9.1	
Gn [SEF/REF] Line Check Trip	2.9.1	
Gn [SEF/REF] Protection Trip 1	2.9.1	

Setting name	Ref	Applied value
Gn [SEF/REF] Reclose DTL 1	2.9.1	sec
Gn [SEF/REF] Protection Trip 2	2.9.1	
Gn [SEF/REF] Reclose DTL 2	2.9.1	sec
Gn[SEF/REF] Protection Trip 3	2.9.1	
Gn [SEF/REF] Reclose DTL 3	2.9.1	sec
Gn [SEF/REF] Protection Trip 4	2.9.1	
Gn [SEF/REF] Reclose DTL 4	2.9.1	sec
Gn [SEF/REF] Shots To Lockout	2.9.1	
Gn SA ARC	2.9.1	
Gn SA Line Check Trip	2.9.1	
Gn SA Reclose DTL 1	2.9.1	sec
Gn SA Reclose DTL 2	2.9.1	sec
Gn SA Reclose DTL 3	2.9.1	sec
Gn SA Reclose DTL 4	2.9.1	sec
Gn SA Shots To Lockout	2.9.1	
Gn SA Trips To Block	2.9.1	
Gn Reclaim Time	2.9	sec
Gn Close Pulse	2.9	sec
Manual Close Delay	2.9.2	sec
Gn LO Recovery	2.9.1	sec
Cold Load Enable	2.6	sec
Cold Load Reset	2.6	sec

### Output Relay Configuration Menu

See also Figure 2-1 on page 12 for the programming matrix.

Setting name	Ref	Applied value
Gn Prot. Healthy	2.14.3	
Gn P/F Starter	2.3.1	
Gn P/F Charact.	2.3.1	
Gn P/F Lowset	2.3.2	
Gn P/F Highset1	2.3.2	
Gn P/F Highset2	2.3.2	
Gn E/F Starter	2.3.1	
Gn E/F Charact.	2.3.1	

Setting name	Ref	Applied value
Gn E/F Lowset	2.3.2	
Gn E/F Highset1	2.3.2	
Gn E/F Highset2	2.3.2	
Gn [SEF/REF] Starter	2.4	
Gn [SEF/REF] Delay1	2.4	
Gn [SEF/REF] Delay2	2.4	
Gn [SEF/REF] Lowset	2.4	
Gn Status 1	2.11	
Gn Status 2	2.11	
Gn Status 3	2.11	
Gn Status 4	2.11	
Gn Status 5	2.11	
Gn Status 6	2.11	
Gn Status 7	2.11	
Gn Status 8	2.11	
Gn Status 9	2.11	
Gn CB Fail 1	2.5	
Gn CB Fail 2	2.5	
Gn ΔTrip Alarm	2.14.1	
Gn Counter Alarm	2.14.1	
Gn FOC Alarm	2.14.1	
Gn $\Sigma I^2$ Alarm	2.14.1	
Gn Power On Count	2.14.3	
Gn Hand Reset	2.11	
Gn Pulsed Relays	2.11	
Gn Lockout Alarm	2.9.1	
Gn Close Pulse	2.9.1	
Gn AUX Close	2.9.1	
Gn ARC Active	2.9.1	
Gn Reclaimed	2.9.1	
Gn SA Blocked	2.9.1	
Gn SA Alarm	2.9.1	
Gn SA Trip	2.9.1	

Setting name	Ref	Applied value
Min O/P Energise Time	2.11	ms

**Status Configuration Menu**

See also Figure 2-1 on page 12 for the programming matrix.

Setting name	Ref	Applied value
Settings Group Select	2.2.1	
Gn Inverted Inputs	2.11	
Gn Latched Inputs	2.11	
Gn P/F Charact. Inhib.	2.3.1	
Gn P/F Lowset Inhib.	2.3.2	
Gn P/F Highset 1 Inhib.	2.3.2	
Gn P/F Highset 2 Inhib.	2.3.2	
Gn E/F Charact. Inhib.	2.3.1	
Gn E/F Lowset Inhib.	2.3.2	
Gn E/F HighSet 1 Inhib.	2.3.2	
Gn E/F HighSet 2 Inhib.	2.3.2	
Gn [SEF/REF] Delay 1 Inhib.	2.4	
Gn [SEF/REF] Delay 2 Inhib.	2.4	
Gn [SEF/REF] Lowset Inhib.	2.4	
Gn Trip Circuit Fail	2.10	
Gn Waveform Trig	2.13.3	
Gn $\Sigma I^2$ Update	2.14.1	
Gn Reset Flag & Output	2.11	
Gn Clock Sync.	2.2.7	
Gn Status 1 P/U Delay	2.11	sec
Gn Status 1 D/O Delay	2.11	sec
Gn Status 2 P/U Delay	2.11	sec
Gn Status 2 D/O Delay	2.11	sec
Gn Status 3 P/U Delay	2.11	sec
Gn Status 3 D/O Delay	2.11	sec
Gn Status 4 P/U Delay	2.11	sec
Gn Status 4 D/O Delay	2.11	sec
Gn Status 5 P/U Delay	2.11	sec
Gn Status 5 D/O Delay	2.11	sec

Setting name	Ref	Applied value
Gn Status 6 P/U Delay	2.11	sec
Gn Status 6 D/O Delay	2.11	sec
Gn Status 7 P/U Delay	2.11	sec
Gn Status 7 D/O Delay	2.11	sec
Gn Status 8 P/U Delay	2.11	sec
Gn Status 8 D/O Delay	2.11	sec
Gn Status 9 P/U Delay	2.11	sec
Gn Status 9 D/O Delay	2.11	sec
Gn ARC Status A	2.9.1	
Gn $\Delta$ Trip Counter Reset	2.14.1	
Gn Counter Reset	2.14.1	
Gn FOC Reset	2.14.1	
Gn Trip & ARC	2.9.2	
Gn Close & Lockin	2.9.2	
Gn Trip & Lockout	2.9.2	
Gn Local Close & Reclaim	2.9.2	
Gn Remote Close Reclaim	2.9.2	
Gn CB Open	2.9.1	
Gn CB Closed	2.9.1	
Gn Reclose Block	2.8.1	
Gn P/F ARC Off	2.9.1	
Gn E/F ARC Off	2.9.1	
Gn [SEF/REF] ARC Off	2.9.1	
Gn Hot Line Working	2.9.4	
Gn Alarm 1 * see note below	2.2.5	
Gn Alarm 2 * see note below	2.2.5	
Gn Alarm 3 * see note below	2.2.5	
Gn Alarm 4 * see note below	2.2.5	
Gn Alarm 5 * see note below	2.2.5	

\* The text of these setting names reflects the value applied to the 'Set Alarm n' settings in the 'System Config.' menu.

**Comms Interface Menu**

<u>Setting name</u>	<u>Ref</u>	<u>Applied value</u>
Comms Baud Rate	4.3.1	baud
Comms Parity	4.3.2	
Relay Address	4.3.3	
Line Idle	4.3.4	
Data Echo	4.3.5	

**Data Storage Menu**

<u>Setting name</u>	<u>Ref</u>	<u>Applied value</u>
Gn Fault Trigger	2.13.2	
Gn Waveform Trig	2.13.3	
Gn Waveform Pre-Trigger	2.13.3	%
Clear All Waveforms	2.13.3	
Clear All Events	2.13.1	
Clear All Faults	2.13.2	

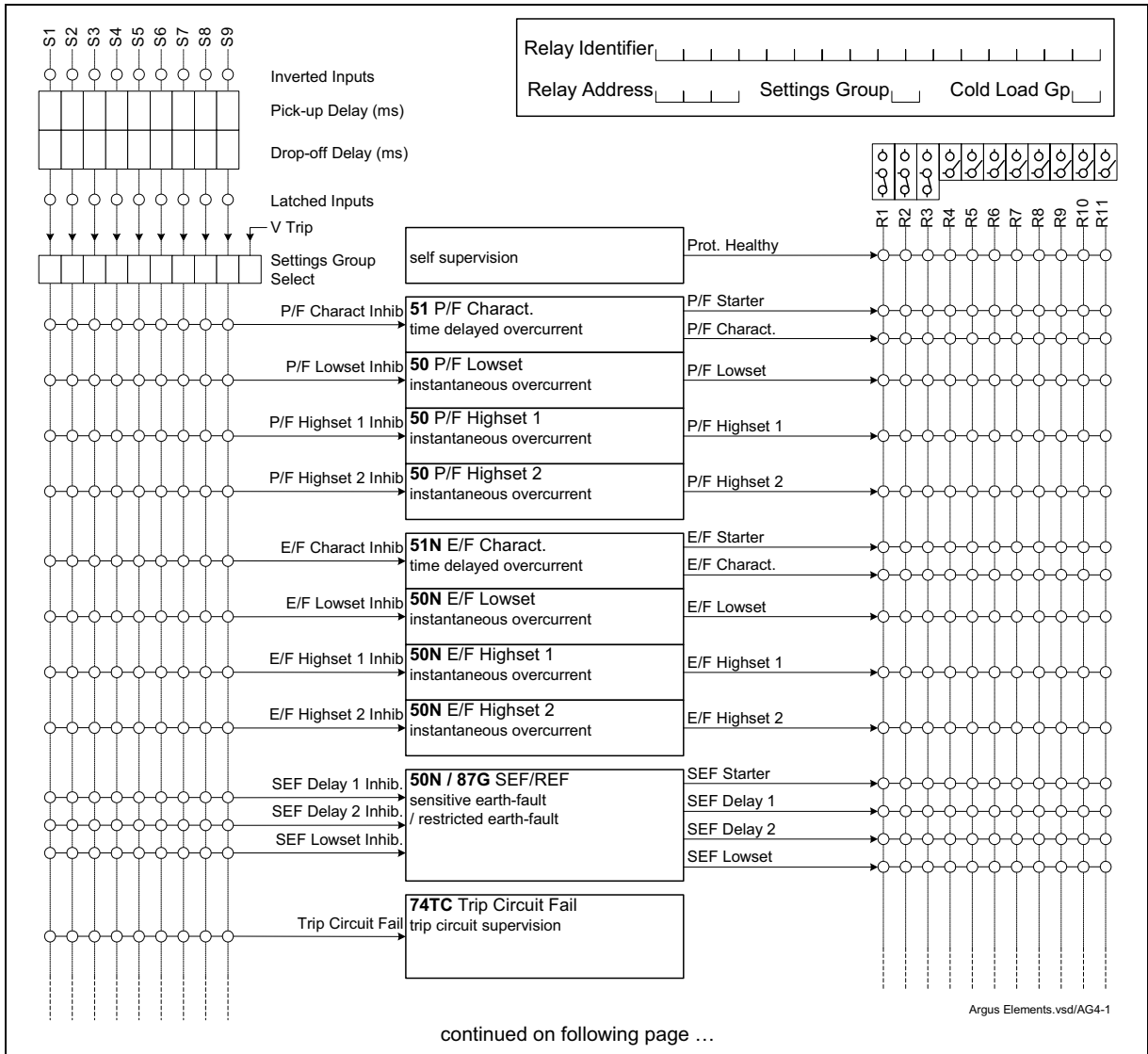
**CB Maintenance Menu**

<u>Setting name</u>	<u>Ref</u>	<u>Applied value</u>
Δ Trip Counter Reset	2.14.1	
Δ Trip Counter Alarm	2.14.1	
Trip Counter Reset	2.14.1	

<u>Setting name</u>	<u>Ref</u>	<u>Applied value</u>
Trip Counter Alarm	2.14.1	
Freq Op Counter Reset.	2.14.1	
Freq Op Counter Alarm	2.14.1	
ΣI <sup>2</sup> Reset	2.14.1	
ΣI <sup>2</sup> Alarm	2.14.1	
Power On Count Reset	2.14.3	
Power On Count Alarm	2.14.3	
O/P Relay Test	2.14.2	

**Linesman Menu**

<u>Setting name</u>	<u>Ref</u>	<u>Applied value</u>
Scada Control	2.15	
Hot Line Working	2.15	
Trip & Lockout	2.15	
Trip & Reclose	2.15	
Close & Reclaim	2.15	
ARC	2.15	
Inst. Lowset	2.15	
Trip Counter Reset	2.15	
SEF	2.15	



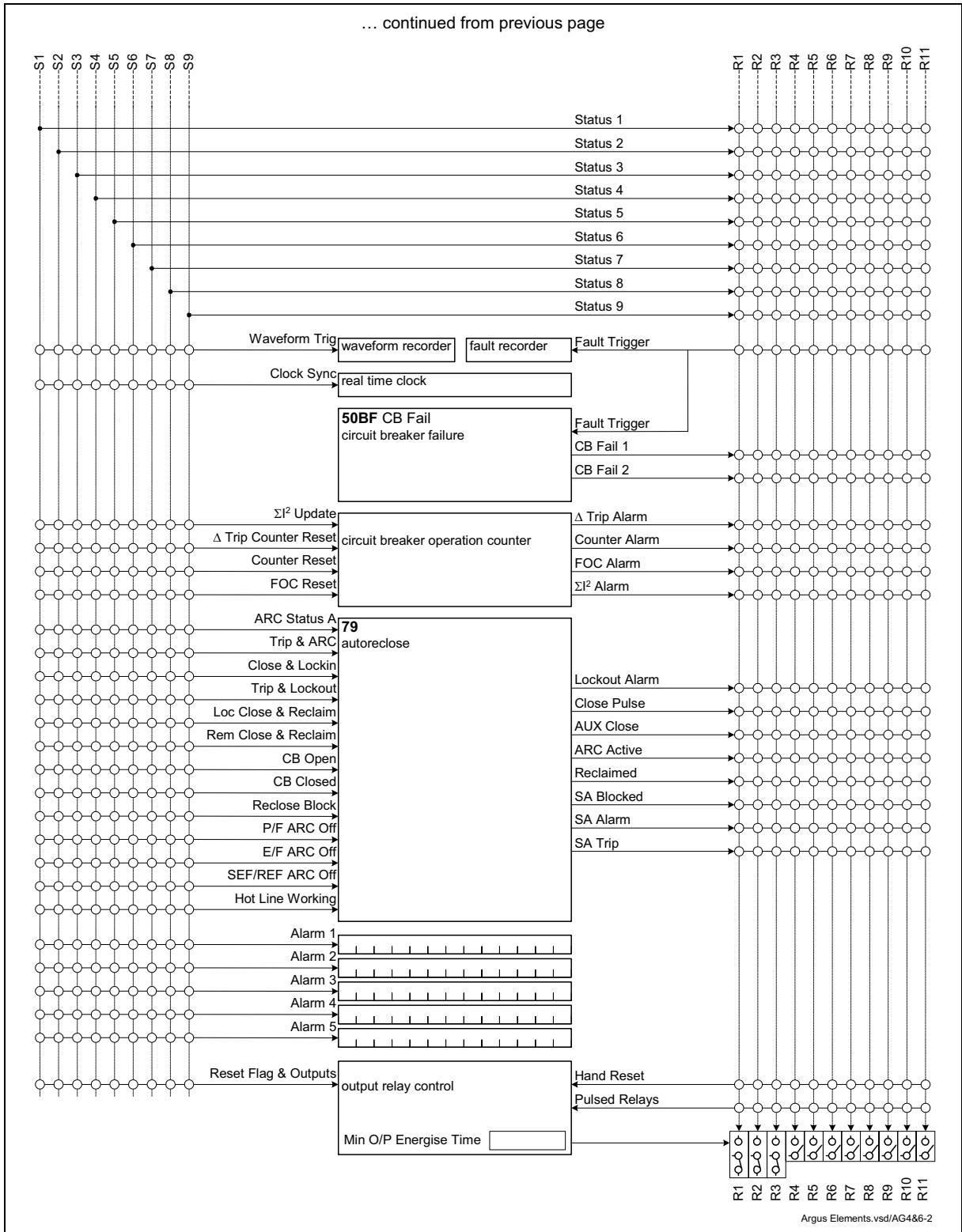


Figure 2-1 Status Input and Output Relay Programming Matrix



## Section 3: IEC 60870-5-103 Definitions

The following tables give information on the IEC 60870-5-103 protocol. A detailed description of all protocol information is available in report no 434/TM/5/13 which can be accessed on the [www.reyrolle-protection.com](http://www.reyrolle-protection.com) in publications section under technical reports, "communications interface manual".

**Table Showing Function Type Numbers Used**

Function Type	Description
160	IEC Overcurrent Protection
164	Reyrolle Overcurrent Protection
254	IEC Generic
255	IEC Global

### Cause of Transmission

The cause of transmission (COT) column of the 'Information Number and Function' table lists possible causes of transmission for these frames. The following abbreviations are used:

**Table Showing Permitted Cause of Transmission Numbers**

Cause of Transmission (COT)	Description
1	Spontaneous Events
2	Cyclic
3	Reset Frame Count Bit (FCB)
4	Reset Communication Unit (CU)
5	Start Restart
6	Power On
7	Test Mode
8	Time Synchronisation
9	General Interrogation
10	Termination of General Interrogation
11	Local Operation
12	Remote Operation
20	Positive Command Acknowledge
21	Negative Command Acknowledge
31	Transmission of Disturbance Data

### Information Number and Function

The following tables list information number and function definitions together with a description of the message and function type and cause of transmission that can result in that message. Not all definitions are available on all relay types – this is dependent on functionality

<b>KEY</b>	<b>FUN</b>	Function Type (defined in IEC60870-5-103 section 7.2.5.1)
	<b>INF</b>	Information Number (defined in IEC60870-5-103 section 7.2.5.2)
	<b>TYP</b>	ASDU Type (defined in IEC60870-5-103 sections 7.3.1 and 7.3.2)
	<b>GI</b>	Event supports General Interrogation x = supported (defined in IEC60870-5-103 section 7.2.5.2)
	<b>COM</b>	Type of command single (ON only) or double (ON/OFF) (defined in IEC60870-5-103 section 7.2.5.2)
	<b>COT</b>	Cause of Transmission (defined in IEC60870-5-103 section 7.2.3, table 5)
	<b>DIR</b>	Direction of event - Raised Only (RO), Raised/Cleared (RC) or Double Point Travelling, Cleared, Raised or Unknown (DBI)
	<b>x</b>	Supported, - Not supported.

Table Showing Command Information (INF) Numbers

FUN	INF	Description	GI	TYP	COT	DIR	Argus 4
160	2	Reset FCB	-	5	3	RO	x
160	3	Reset CU	-	5	4	RO	x
160	4	Start/Restart	-	5	5	RO	x
160	5	Power On	-	5	6	RO	x
160	16	ARC in progress	x	1	1, 9, 12, 20, 21	RC	x
160	19	LEDs reset	-	1	1, 7, 11, 12, 20, 21	RO	x
160	21	Trip Test	x	1	1, 9	RC	x
160	22	Settings changed	x	1	1, 9, 11, 12	RC	x
160	23	Setting G1 selected	x	1	1, 9, 11, 12, 20, 21	RC	x
160	24	Setting G2 selected	x	1	1, 9, 11, 12, 20, 21	RC	x
160	25	Setting G3 selected	x	1	1, 9, 11, 12, 20, 21	RC	x
160	26	Setting G4 selected	x	1	1, 9, 11, 12, 20, 21	RC	x
160	27	Input 1	x	1	1, 9	RC	x
160	28	Input 2	x	1	1, 9	RC	x
160	29	Input 3	x	1	1, 9	RC	x
160	30	Input 4	x	1	1, 9	RC	x
160	36	Trip circuit fail	x	1	1, 9	RC	x
160	46	Group Warning	x	1	1, 9	RC	x
160	47	Alarm	x	1	1, 9	RO	x
160	64	A-starter	x	2	1, 9	RC	x
160	65	B-starter	x	2	1, 9	RC	x
160	66	C-starter	x	2	1, 9	RC	x
160	67	E-starter	x	2	1, 9	RC	x
160	68	General trip	-	2	1	RO	x
160	69	A-general trip	-	2	1	RO	x
160	70	B-general trip	-	2	1	RO	x
160	71	C-general trip	-	2	1	RO	x
160	84	General starter	x	2	1, 9	RC	x
160	85	Circuit breaker fail 1	-	2	1	RO	x
160	91	P/F-general HS trip	-	2	1	RO	x
160	92	E/F-general trip	-	2	1	RO	x

FUN	INF	Description	GI	TYP	COT	DIR	Argus 4
160	93	E/F-general HS trip	-	2	1	RO	x
160	128	CB on by auto reclose	-	1	1	DP	x
160	130	Reclose blocked	x	1	1, 9	RC	x
160	144	Measurand $I_{L1}$ <sup>1</sup>	-	3.1	2,7	-	x
160	148	Measurand $I_{L1,2,3}, {}^1V_{L1,2,3}, P, Q$	-	9	2,7	-	
164	0	Data lost	-	1	1	RO	x
164	1	A-lowset starter	-	2	1	RC	x
164	2	B-lowset starter	-	2	1	RC	x
164	3	C-lowset starter	-	2	1	RC	x
164	4	E-lowset starter	-	2	1	RC	x
164	5	A-lowset trip	-	2	1	RO	x
164	6	B-lowset trip	-	2	1	RO	x
164	7	C-lowset trip	-	2	1	RO	x
164	8	E-lowset trip	-	2	1	RO	x
164	9	A-delayed trip	-	2	1	RO	x
164	10	B-delayed trip	-	2	1	RO	x
164	11	C-delayed trip	-	2	1	RO	x
164	12	E-delayed trip	-	2	1	RO	x
164	13	A-HS1 trip	-	2	1	RO	x
164	14	B-HS1 trip	-	2	1	RO	x
164	15	C-HS1 trip	-	2	1	RO	x
164	16	E-HS1 trip	-	2	1	RO	x
164	17	A-HS2 trip	-	2	1	RO	x
164	18	B-HS2 trip	-	2	1	RO	x
164	19	C-HS2 trip	-	2	1	RO	x
164	20	E-HS2 trip	-	2	1	RO	x
164	21	SEF/REF starter	x	2	1, 9	RC	x
164	23	SEF/REF lowset trip	-	2	1	RC	x
164	24	SEF/REF stage 1 trip	-	2	1	RC	x
164	25	SEF/REF stage 2 trip	-	2	1	RC	x
164	26	A-HS1 starter	-	2	1	RC	x
164	27	B-HS1 starter	-	2	1	RC	x
164	28	C-HS1 starter	-	2	1	RC	x

<sup>1</sup> Current Measurand Scaling can be User set to either 1.2 x In or 2.4 x In

FUN	INF	Description	GI	TYP	COT	DIR	Argus 4
164	29	E-HS1 starter	-	2	1	RC	x
164	30	A-HS2 starter	-	2	1	RC	x
164	31	B-HS2 starter	-	2	1	RC	x
164	32	C-HS2 starter	-	2	1	RC	x
164	33	E-HS2 starter	-	2	1	RC	x
164	34	Circuit breaker open	x	1	1, 9	RO	x
164	35	Setting G5 selected	x	1	1, 9, 11, 12, 20, 21	RC	x
164	36	Setting G6 selected	x	1	1, 9, 11, 12, 20, 21	RC	x
164	37	Setting G7 selected	x	1	1, 9, 11, 12, 20, 21	RC	x
164	38	Setting G8 selected	x	1	1, 9, 11, 12, 20, 21	RC	x
164	39	Circuit breaker fail 2	-	2	1	RO	x
164	41	CB close fail	x	1	1, 9	RO	x
164	43	CB DBI state	x	1	1, 9	RO	x
164	44	External Trip	-	2	1	RO	x
164	45	Input 5	x	1	1, 9	RC	x
164	46	Input 6	x	1	1, 9	RC	x
164	47	Input 7	x	1	1, 9	RC	x
164	48	Input 8	x	1	1, 9	RC	x
164	49	Input 9	x	1	1, 9	RC	x
164	51	Output 1	x	1	1, 9, 12, 20, 21	RC	x
164	52	Output 2	x	1	1, 9, 12, 20, 21	RC	x
164	53	Output 3	x	1	1, 9, 12, 20, 21	RC	x
164	54	Output 4	x	1	1, 9, 12, 20, 21	RC	x
164	55	Output 5	x	1	1, 9, 12, 20, 21	RC	x
164	56	Output 6	x	1	1, 9, 12, 20, 21	RC	x
164	57	Output 7	x	1	1, 9, 12, 20, 21	RC	x
164	58	Output 8	x	1	1, 9, 12, 20, 21	RC	
164	59	Output 9	x	1	1, 9, 12, 20, 21	RC	
164	60	Output 10	x	1	1, 9, 12, 20, 21	RC	
164	61	Output 11	x	1	1, 9, 12, 20, 21	RC	
164	62	Forward A	x	2	1, 9	RC	x
164	63	Reverse A	x	2	1, 9	RC	x
164	64	Forward B	x	2	1, 9	RC	x
164	65	Reverse B	x	2	1, 9	RC	x
164	66	Forward C	x	2	1, 9	RC	x
164	67	Reverse C	x	2	1, 9	RC	x
164	68	Forward E	x	2	1, 9	RC	x
164	69	Reverse E	x	2	1, 9	RC	x

FUN	INF	Description	GI	TYP	COT	DIR	Argus 4
164	70	Trip count alarm	x	1	1, 9	RC	x
164	70	Trip count alarm	x	4	1, 9	RC	
164	71	CB maintenance alarm	x	1	1, 9	RC	x
164	71	CB maintenance alarm	x	4	1, 9	-	
164	72	Frequent operations exceeded	x	1	1, 9	RC	x
164	73	Delta Trip Counter Alarm	x	1	1, 9	RC	x
164	79	Voltage Block	x	1	1, 9	RC	
164	80	Waveform stored	-	1	1, 12, 20, 21	RO	x
164	81	Remote control interrupted	-	1	1	RO	x
164	82	Trip and Lockout	-	1	1, 12, 20, 21	RO	x
164	83	Close and Reclaim	-	1	1, 12, 20, 21	RO	x
164	84	Trip And Reclose	-	1	1, 12, 20, 21	RO	x
164	85	Circuit breaker closed	x	1	1, 9	RO	x
164	86	Close And Lockin	-	1	1, 12, 20, 21	RO	x
164	87	Reclose delay	x	1	1, 9	RC	x
164	88	Reclaim	x	1	1, 9	RC	x
164	89	Lockout	x	1	1, 9	RC	x
164	90	Forward SEF	x	2	1, 9	RC	x
164	91	Reverse SEF	x	2	1, 9	RC	x
164	92	Power On Counter Alarm	x	1	1, 9	RC	x
164	97	CT Failure	x	1	1, 9	RC	
164	100	Cold load pickup	x	1	1, 9, 12, 20, 21	RC	x
164	101	Cold load trip	-	2	1	RO	x
164	102	Line check trip	-	2	1	RO	x
164	103	ARC start A	x	1	1, 9	RC	x
164	104	A backup time	-	1	1	RC	x
164	105	A backup trip	-	1	1	RC	x
164	106	External trip block	x	1	1, 9	RC	x
164	110	SEF off	x	1	1, 9, 12, 20, 21	RC	x
164	111	All ARC off	x	1	1, 9	RC	x
164	112	P/F ARC off	x	1	1, 9, 12, 20, 21	RC	x
164	113	E/F ARC off	x	1	1, 9, 12, 20, 21	RC	x
164	114	SEF ARC off	x	1	1, 9, 12, 20, 21	RC	x
164	115	All inst off	x	1	1, 9, 12, 20, 21	RC	x
164	116	P/F inst off	x	1	1, 9, 12, 20, 21	RC	x
164	117	E/F inst off	x	1	1, 9, 12, 20, 21	RC	x

FUN	INF	Description	GI	TYP	COT	DIR	Argus 4
164	118	SEF inst off	x	1	1, 9, 12, 20, 21	RC	x
164	119	Hot line working	x	1	1, 9, 12, 20, 21	RC	x
164	120	Scada Control	x	1	1, 9	RC	x
164	121	General alarm 1	x	1	1, 9	RC	x
164	122	General alarm 2	x	1	1, 9	RC	x
164	123	General alarm 3	x	1	1, 9	RC	x
164	124	General alarm 4	x	1	1, 9	RC	x
164	125	General alarm 5	x	1	1, 9	RC	x
164	131	Va/Vab starter	x	2	1, 9	RC	
164	132	Vb/Vbc starter	x	2	1, 9	RC	
164	133	Vc/Vca starter	x	2	1, 9	RC	
164	170	V starter	x	2	1, 9	RC	
164	182	V trip	-	2	1	RO	
164	190	Voltage Memory A	x	1	1, 9	RC	
164	191	Voltage Memory B	x	1	1, 9	RC	
164	192	Voltage Memory C	x	1	1, 9	RC	
164	240	Ia Fault Current	x	4	1, 9	-	
164	241	Ib Fault Current	x	4	1, 9	-	
164	242	Ic Fault Current	x	4	1, 9	-	
164	243	Ie Fault Current	x	4	1, 9	-	
164	244	Isef Fault Current	x	4	1, 9	-	
164	245	Va Fault Voltage	x	4	1, 9	-	
164	246	Vb Fault Voltage	x	4	1, 9	-	
164	247	Vc Fault Voltage	x	4	1, 9	-	
164	248	Vn Fault Voltage	x	4	1, 9	-	
255	0	Time Synchronisation	-	6	8	-	x
255	0	End of General Interrogation	-	8	10	-	x

Table Showing Command Information (INF) Numbers

FUN	INF	Description	COM	TYP	COT	Argus 4
160	16	Auto-recloser ON/OFF	ON/OFF	20	20	x
160	19	Reset Flag & Outputs	ON	20	20	x

FUN	INF	Description	COM	TYP	COT		Argus 4
160	23	Settings Group 1 Select	ON	20	20		x
160	24	Settings Group 2 Select	ON	20	20		x
160	25	Settings Group 3 Select	ON	20	20		x
160	26	Settings Group 4 Select	ON	20	20		x
164	35	Settings Group 5 Select	ON	20	20		x
164	36	Settings Group 6 Select	ON	20	20		x
164	37	Settings Group 7 Select	ON	20	20		x
164	38	Settings Group 8 Select	ON	20	20		x
164	51	Energise Output 1	ON	20	20		x
164	52	Energise Output 2	ON	20	20		x
164	53	Energise Output 3	ON	20	20		x
164	54	Energise Output 4	ON	20	20		x
164	55	Energise Output 5	ON	20	20		x
164	56	Energise Output 6	ON	20	20		x
164	57	Energise Output 7	ON	20	20		x
164	58	Energise Output 8	ON	20	20		
164	59	Energise Output 9	ON	20	20		
164	60	Energise Output 10	ON	20	20		
164	61	Energise Output 11	ON	20	20		
164	80	Trigger Waveform Storage	ON	20	20		x
164	82	Trip and Lockout	ON	20	20		x
164	83	Close and Reclaim	ON	20	20		x
164	84	Trip And Reclose	ON	20	20		x
164	86	Close And Lockin	ON/OFF	20	20		x
164	100	Cold load pickup	ON/OFF	20	20		x
164	110	SEF	ON/OFF	20	20		x
164	112	P/F ARC Inhibit	ON/OFF	20	20		x
164	113	E/F ARC Inhibit	ON/OFF	20	20		x
164	114	SEF ARC Inhibit	ON/OFF	20	20		x
164	115	Instantaneous	ON/OFF	20	20		x
164	116	P/F Instantaneous	ON/OFF	20	20		x
164	117	E/F Instantaneous	ON/OFF	20	20		x
164	118	SEF Instantaneous	ON/OFF	20	20		x

FUN	INF	Description	COM	TYP	COT		Argus 4
164	119	Hot line working	ON/OFF	20	20		x
164	129	Reset Energy Meters	ON/OFF	20	20		
164	130	Reset Maximum Demand	ON/OFF	20	20		x
255	0	Initiate General Interrogation	-	7	9	-	x
255	0	Time Synchronisation	-	6	8		x

Note: Events listed as responding to a General Interrogation (**GI**) will be raised and cleared (**RC**); other events are raised only (**RO**) and do not respond to a **GI**.



## Section 4: Application Diagrams

The following pages contain example application diagrams for a variety of connections, showing various hardware options.

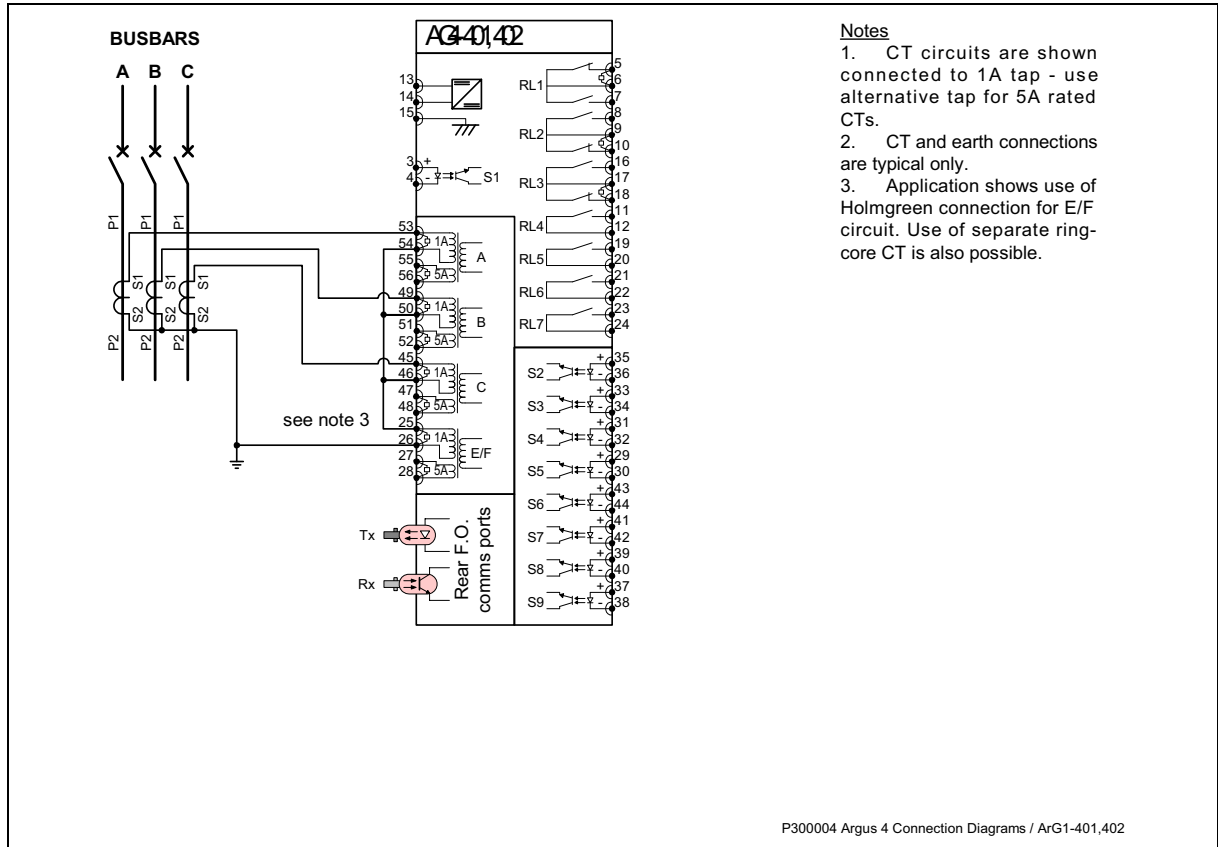


Figure 4-1 Typical Connection for 3 Phase-fault and Earth-fault Protection

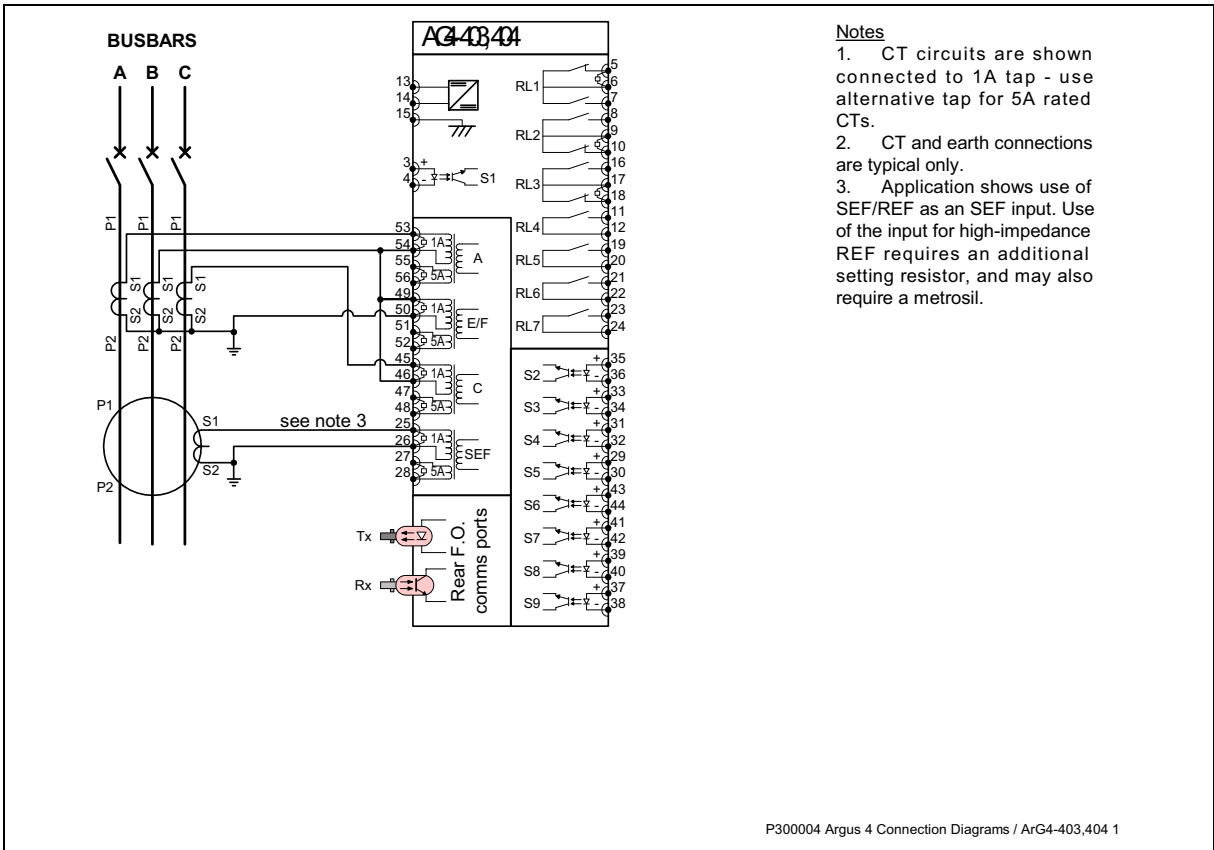


Figure 4-2 Typical Connection for 2 Phase-fault, Earth-fault and Sensitive Earth-fault Protection

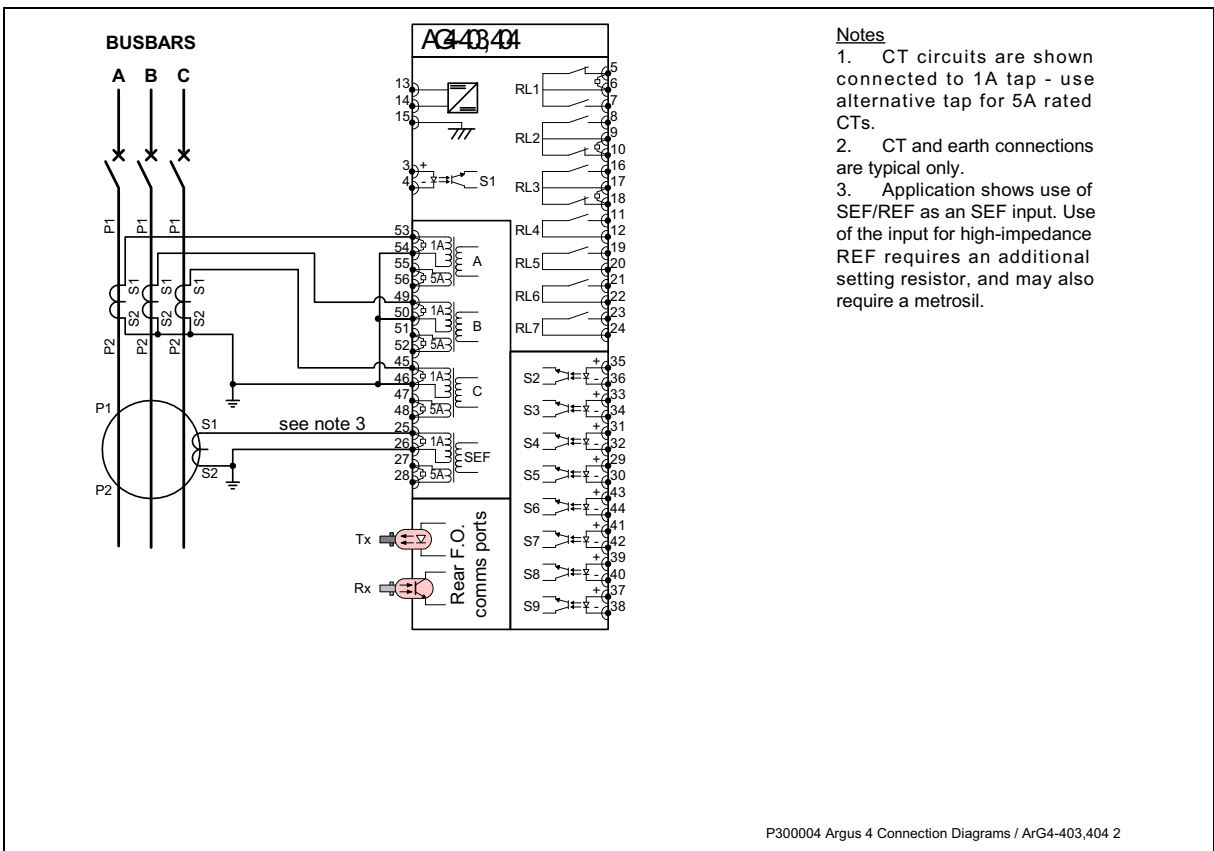


Figure 4-3 Typical Connection for 3 Phase-fault and Sensitive Earth-fault Protection

# 7SG11Argus

Overcurrent Protection Relays

## Document Release History

This document is issue 2010/02. The list of revisions up to and including this issue is:

Pre release

2010/02	Document reformat due to rebrand
2005/06	Third issue: Editorial modifications, software revision histories updated
2004/07	Second issue. Power On alarm added
2002/12	First issue

The copyright and other intellectual property rights in this document, and in any model or article produced from it (and including any registered or unregistered design rights) are the property of Siemens Protection Devices Limited. No part of this document shall be reproduced or modified or stored in another form, in any data retrieval system, without the permission of Siemens Protection Devices Limited, nor shall any model or article be reproduced from this document unless Siemens Protection Devices Limited consent.

While the information and guidance given in this document is believed to be correct, no liability shall be accepted for any loss or damage caused by any error or omission, whether such error or omission is the result of negligence or any other cause. Any and all such liability is disclaimed.

## Software Release History

The software listed below is used in one of more types Argus relay. The list of software revisions applying to Argus 6, up to and including this document issue is:

Mar 2005	2716H80005 R5	Mods to reclose blocked Mod to "Checking Settings" screen at switch on
Jul 2003	2716H80005 R3	Function added: Status input Inversion Minor change: Latched input 8/9 display corrected
Mar 2003	2716H80005 R2	Function added: Power On count alarm Minor change: IEC 870-5-103 Time Sync optimised Minor change: communications with ReyDisp Minor change: Trip & Reclose action when no CB - corrected
Feb 2002	2716H80005R1	Function added: trip count alarm display added Function added: setting added to hide/show linesman mode display Function added: close and reclaim command split in two – one for local (delayed) and one for remote (no delay) Minor change: fault display shows lockout due to hot line working Minor change: communications – general command blocking Minor change: trip count – non-fault trips and alarm action
Nov 2000	2716H80004 R1/2	Internal Evaluation code - version not released
Sep 1999	2716H80003 R2	Minor change: on-screen alarm display Minor change: frequent operation counter reset Minor change: trip circuit supervision alarm
Nov 1998	2716H80001 R3	First release

## Hardware Release History

The Argus hardware is used in many different relays. The list of hardware revisions applying to Argus 6, up to and including this document issue is:

Mar 2002	Appearance change:	modification to grey fascia design – logo, dark grey band, buttons and label.
Jan 2002	External change:	SMA fibre-optic connectors replaced by ST <sup>TM</sup> (BFOC/2.5) by default.
Jul 1999	Appearance change:	introduction of grey fascia design to replace existing black fascia.
Jul 1999	External change:	introduction of Epsilon case and terminal blocks
Nov 1998	First release	

## Contents

Software Release History .....	2
Hardware Release History .....	2
Contents .....	3
List of Figures .....	3
Section 1: Variants .....	4
Section 2: Settings .....	6
Section 3: IEC 60870-5-103 Definitions .....	14
Section 4: Application Diagrams .....	21

## List of Figures

Figure 2-1 Status Input and Output Relay Programming Matrix .....	13
Figure 4-1 Typical Connection for 3 Directional Phase-fault and Directional Earth-fault .....	21
Figure 4-2 Typical Connection for 3 Directional Phase-fault and Sensitive Earth-fault .....	22
Figure 4-3 Typical Connection for 3 Phase-fault and Directional Earth-fault Protection .....	22

## Section 1: Variants

This document applies to the Argus relays listed in the following table.

The MLFB Structure references the complete number for each relay:

- 7SG11nn-nxxnn-nxA0

where n is a digit and x is a letter.

The table uses two references for most relays, each of which is valid:

- an 'Order code' of the form AGn-nnn, and
- a 'Type' of the form GAFnnnX

where n is a digit and X is a letter.

Protection	Application Diagram	I/O	Order code / Type				
			30/48 aux.		110/220 aux.		
			30V status	48V status	48V status	110V status	220V status
3 directional phase-fault and directional earth-fault	Fig. 4-1	9 SI 7 OR	GAF911C	<b>AG6-401</b> GAF913C	<b>AG6-402</b> GAF914C		GAF915C
3 directional phase-fault and SEF/REF	Fig. 4-2	9 SI 7 OR	GAF921C	<b>AG6-403</b> GAF923C	<b>AG6-404</b> GAF924C		
3 phase-fault and directional. earth-fault	Fig. 4-3	9 SI 7 OR	GAF931C	<b>AG6-405</b> GAF933C	<b>AG6-406</b> GAF934C		

## Ordering Information – 7SG1164 Argus 6

Product description	Variants	Order No.
---------------------	----------	-----------

Directional O/C relay with auto re-lose  
 Bi-directional version of ARGUS 4.

7 S G 1 1 6       A 0

Number of elements  
 Four pole relay

4

Auxiliary supply /binary input voltage

- 24/30/48 V DC auxiliary, 30 V binary input
- 110/220 V DC auxiliary, 30 V binary input
- 24/30/48 V DC auxiliary, 48 V binary input
- 110/220 V DC auxiliary, 48 V binary input <sup>1)</sup>
- 110/220 V DC auxiliary, 110 V low burden binary input
- 110/220 V DC auxiliary, 220 V low burden binary input

- 0
- 1
- 2
- 3
- 4
- 5

Type of elements

- 3 pole phase-fault directional and sensitive/restricted earth-fault (SEF/REF)
- 3 pole phase-fault directional and earth-fault directional or 3 pole phase-fault directional and earth-fault
- 3 pole phase-fault directional and earth-fault directional or 3 pole phase-fault directional and earth-fault
- 3 pole phase-fault and earth-fault directional
- 3 pole phase-fault and earth-fault directional

- N
- P
- P
- 1 E
- 4 E
- 5 E
- 2 D
- 3 D

Nominal current

- 1/ 5 A

A

I/O range

- 9 Binary Inputs / 7 Binary Outputs (incl. 3 changeover)

2

Communication interface

- Fibre optic (ST-connector) / IEC 60870-5-103 or Modbus RTU
- RS485 interface / IEC 60870-5-103 or Modbus RTU

- 1
- 2

Directional measurement characteristic angle (CA)

- +30°, +45° for phase faults
- 0°, -15°, -45°, -65° for earth faults
- 0°, -15°, -45°, -90° for earth faults
- +30°, +45° for phase faults and 0°, -15°, -45°, -65° for earth faults
- +30°, +45° for phase faults and 0°, -15°, -45°, -90° for earth faults

- 1
- 2
- 3
- 4
- 5

Housing size

- Case size E6 (4U high)
- Case size E8 (4U high)

- D
- E

## Section 2: Settings

Relay Type \_\_\_\_\_

Serial Number \_\_\_\_\_

Substation \_\_\_\_\_

Feeder Identity \_\_\_\_\_

### Notes on Tables

All settings found in the Argus 6 relay types are listed below. Within the list some settings (indicated with greyed cells) are not always visible, for the following reasons:

- Depending on the version of the relay, a particular function and hence its related settings may not be present, e.g. on a 2 phase-fault and SEF relay any settings related to earth-fault will not be present.
- Depending on the value of some settings, other settings will be hidden, e.g. if the main characteristic is set to DTL, rather than an IDMT characteristic, the time multiplier setting will be hidden and replaced by a time delay setting.

Some settings in the tables show text in square brackets, e.g. '[SEF/REF] Current Setting'. This indicates different text that may be displayed, depending on the value of other settings, i.e. 'SEF Current Setting' or 'REF Current Setting' dependent on the value of the 'Earth Fault Mode Select' setting.

The second column in the tables ('Ref') provides a reference to the section in the Technical Reference (publication P20007 issue 2002/12) that describes the setting.

The third column is left blank to allow users to complete the table with applied settings.

### System Config. Menu

Setting name	Ref	Applied value
Active Settings Group	2.2.1	
Settings Group Edit/View	2.2.1	
Cold Load Pickup Group	2.6	
Copy Group	2.2.1	
Power System Frequency	2.2.2	Hz
Set Pole B Type	2.2.3	
Earth Fault Mode Select	2.2.3	
P/F Rating (In)	2.2.3	A
E/F Rating (In)	2.2.3	A
SEF/REF Rating (In)	2.2.3	A
P/F CT Ratio	2.2.3	
E/F CT Ratio	2.2.3	
SEF/REF CT Ratio	2.2.3	
Current Display	2.2.3	
Set Identifier	2.2.4	
SET Alarm 1	2.2.5	
SET Alarm 2	2.2.5	

Setting name	Ref	Applied value
SET Alarm 3	2.2.5	
SET Alarm 4	2.2.5	
SET Alarm 5	2.2.5	
FWD Name Tag	2.2.6	
REV Name Tag	2.2.6	
Calendar – Set Date	2.2.7	
Clock - Set Time	2.2.7	
Clock Sync. From Status	2.2.7	
Default Screen Time	2.2.8	
Change Password	2.2.9	
Linesman Display	2.15	

### Protection Menu

For non-directional settings use the Gn[F] settings, ignoring the forward (F) notation.

Setting name	Ref	Applied value
Gn P/F Charact. Dir Control	2.3.1	
Gn[F] P/F Charact. Setting	2.3.1	xin
Gn[F] P/F Charact.	2.3.1	
Gn[F] P/F Charact. Time Mult	2.3.1	



Setting name	Ref	Applied value
Gn P/F Charact. Delay	2.3.1	sec
Gn P/F Charact. Setting	2.3.1	xIn
Gn P/F Charact.	2.3.1	
Gn P/F Charact. Time Mult	2.3.1	
Gn P/F Charact. Delay	2.3.1	sec
Gn P/F Lowset Dir Control	2.3.2	
Gn P/F Lowset Setting	2.3.2	xIn
Gn P/F Lowset Delay	2.3.2	sec
Gn P/F Lowset Setting	2.3.2	xIn
Gn P/F Lowset Delay	2.3.2	sec
Gn P/F Highset1 Dir Control	2.3.2	
Gn P/F Highset1 Setting	2.3.2	xIn
Gn P/F Highset1 Delay	2.3.2	sec
Gn P/F Highset1 Setting	2.3.2	xIn
Gn P/F Highset1 Delay	2.3.2	sec
Gn P/F Highset2 Dir Control	2.3.2	
Gn P/F Highset2 Setting	2.3.2	xIn
Gn P/F Highset2 Delay	2.3.2	sec
Gn P/F Highset2 Setting	2.3.2	xIn
Gn P/F Highset2 Delay	2.3.2	sec
Gn E/F Charact. Dir Control	2.3.1	
Gn E/F Charact. Setting	2.3.1	xIn
Gn E/F Charact.	2.3.1	
Gn E/F Charact. Time Mult	2.3.1	
Gn E/F Charact. Delay	2.3.1	sec
Gn E/F Charact. Setting	2.3.1	xIn
Gn E/F Charact.	2.3.1	
Gn E/F Charact. Time Mult	2.3.1	
Gn E/F Charact. Delay	2.3.1	sec
Gn E/F Lowset Dir Control	2.3.2	
Gn E/F Lowset Setting	2.3.2	xIn
Gn E/F Lowset Delay	2.3.2	sec

Setting name	Ref	Applied value
Gn E/F Lowset Setting	2.3.2	xIn
Gn E/F Lowset Delay	2.3.2	sec
Gn E/F Highset1 Dir Control	2.3.2	
Gn E/F Highset1 Setting	2.3.2	xIn
Gn E/F Highset1 Delay	2.3.2	sec
Gn E/F Highset1 Setting	2.3.2	xIn
Gn E/F Highset1 Delay	2.3.2	sec
Gn E/F Highset2 Dir Control	2.3.2	
Gn E/F Highset2 Setting	2.3.2	xIn
Gn E/F Highset2 Delay	2.3.2	sec
Gn E/F Highset2 Setting	2.3.2	xIn
Gn E/F Highset2 Delay	2.3.2	sec
Gn [SEF/REF] Current Setting	2.4	
Gn [SEF/REF] 1st Time Delay	2.4	sec
Gn [SEF/REF] 2nd Time Delay	2.4	sec
Gn [SEF/REF] Lowset Delay	2.4	sec
Gn CB Fail Time Delay1	2.5	sec
Gn CB Fail Time Delay2	2.5	sec
Gn Relay Reset Delay	2.3.3	sec
Gn Backup Alarm SA	2.9.1	sec
Gn Backup Trip SA	2.9.1	Sec

**Directional Menu**

Setting name	Ref	Applied value
Gn 2-Out-Of-3 Gate Logic	2.7	
Gn P/F Charact. Angle	2.7	
Gn E/F Charact. Angle	2.7	

**Auto-reclose Menu**

Setting name	Ref	Applied value
Gn Line Check Trip	2.9.1	
Gn Seq Edit/View	2.9	
GnP/F ARC	2.9.1	
GnP/F Line Check Trip	2.9.1	
GnP/F Protection Trip 1	2.9.1	








Setting name	Ref	Applied value
GnP/F Reclose DTL 1	2.9.1	sec
GnP/F Protection Trip 2	2.9.1	
GnP/F Reclose DTL 2	2.9.1	sec
GnP/F Protection Trip 3	2.9.1	
GnP/F Reclose DTL 3	2.9.1	sec
GnP/F Protection Trip 4	2.9.1	
GnP/F Reclose DTL 4	2.9.1	sec
GnP/F Shots To Lockout	2.9.1	
GnP/F HS1 Trips to Lockout	2.9.1	
GnP/F HS2 Trips to Lockout	2.9.1	
GnE/F ARC	2.9.1	
GnE/F Line Check Trip	2.9.1	
GnE/F Protection Trip 1	2.9.1	
GnE/F Reclose DTL 1	2.9.1	sec
GnE/F Protection Trip 2	2.9.1	
GnE/F Reclose DTL 2	2.9.1	sec
GnE/F Protection Trip 3	2.9.1	
GnE/F Reclose DTL 3	2.9.1	sec
GnE/F Protection Trip 4	2.9.1	
GnE/F Reclose DTL 4	2.9.1	sec
GnE/F Shots To Lockout	2.9.1	
GnE/F HS1 Trips to Lockout	2.9.1	
GnE/F HS2 Trips to Lockout	2.9.1	
Gn[SEF/REF] ARC	2.9.1	
Gn[SEF/REF] Line Check Trip	2.9.1	
Gn[SEF/REF] Protection Trip 1	2.9.1	
Gn[SEF/REF] Reclose DTL 1	2.9.1	sec
Gn[SEF/REF] Protection Trip 2	2.9.1	
Gn[SEF/REF] Reclose DTL 2	2.9.1	sec
Gn[SEF/REF] Protection Trip 3	2.9.1	
Gn[SEF/REF] Reclose DTL 3	2.9.1	sec
Gn[SEF/REF] Protection Trip 4	2.9.1	
Gn[SEF/REF] Reclose DTL 4	2.9.1	sec

Setting name	Ref	Applied value
Gn[SEF/REF] Shots To Lockout	2.9.1	
GnSA ARC	2.9.1	
GnSA Line Check Trip	2.9.1	
GnSA Reclose DTL 1	2.9.1	sec
GnSA Reclose DTL 2	2.9.1	sec
GnSA Reclose DTL 3	2.9.1	sec
GnSA Reclose DTL 4	2.9.1	sec
GnSA Shots To Lockout	2.9.1	
GnSA Trips To Block	2.9.1	
Gn Reclaim Time	2.9	sec
Gn Close Pulse	2.9	sec
Manual Close Delay	2.9.2	sec
Gn LO Recovery	2.9.1	sec
Cold Load Enable	2.6	sec
Cold Load Reset	2.6	sec

#### Output Relay Configuration Menu

See also Figure 2-1 on page 13 for the programming matrix. For non-directional settings use the Gn[F] settings, ignoring the forward (F) notation.

Setting name	Ref	Applied value
Gn Prot. Healthy	2.14.3	
Gn[F] P/F Starter	2.3.1	
Gn[R] P/F Starter	2.3.1	
Gn[F] P/F Charact.	2.3.1	
Gn[R] P/F Charact.	2.3.1	
Gn[F] P/F Lowset	2.3.2	
Gn[R] P/F Lowset	2.3.2	
Gn[F] P/F Highset1	2.3.2	
Gn[R] P/F Highset1	2.3.2	
Gn[F] P/F Highset2	2.3.2	
Gn[R] P/F Highset2	2.3.2	
Gn[F] E/F Starter	2.3.1	
Gn[R] E/F Starter	2.3.1	
Gn[F] E/F Charact.	2.3.1	

Setting name	Ref	Applied value
Gn  E/F Charact.	2.3.1	
Gn  E/F Lowset	2.3.2	
Gn  E/F Lowset	2.3.2	
Gn  E/F Highset1	2.3.2	
Gn  E/F Highset1	2.3.2	
Gn  E/F Highset2	2.3.2	
Gn  E/F Highset2	2.3.2	
Gn [SEF/REF] Starter	2.4	
Gn [SEF/REF] Delay1	2.4	
Gn [SEF/REF] Delay2	2.4	
Gn [SEF/REF] Lowset	2.4	
Gn P/F FWD Block	2.7	
Gn P/F REV Block	2.7	
Gn E/F FWD Block	2.7	
Gn E/F REV Block	2.7	
Gn Status 1	2.11	
Gn Status 2	2.11	
Gn Status 3	2.11	
Gn Status 4	2.11	
Gn Status 5	2.11	
Gn Status 6	2.11	
Gn Status 7	2.11	
Gn Status 8	2.11	
Gn Status 9	2.11	
Gn CB Fail 1	2.5	
Gn CB Fail 2	2.5	
Gn $\Delta$ Trip Alarm	2.14.1	
Gn Counter Alarm	2.14.1	
Gn FOC Alarm	2.14.1	
Gn $\Sigma I^2$ Alarm	2.14.1	
Gn Power On Count	2.14.3	
Gn Hand Reset	2.11	
Gn Pulsed Relays	2.11	

Setting name	Ref	Applied value
Gn Lockout Alarm	2.9.1	
Gn Close Pulse	2.9.1	
Gn AUX Close	2.9.1	
Gn ARC Active	2.9.1	
Gn Reclaimed	2.9.1	
Gn SA Blocked	2.9.1	
Gn SA Alarm	2.9.1	
Gn SA Trip	2.9.1	
Min O/P Energise Time	2.11	ms

### Status Configuration Menu

See also Figure 2-1 on page 13 for the programming matrix.

Setting name	Ref	Applied value
Settings Group Select	2.2.1	
Gn Inverted Inputs	2.11	
Gn Latched Inputs	2.11	
Gn P/F Charact. Inhib.	2.3.1	
Gn P/F Lowset Inhib.	2.3.2	
Gn P/F Highset 1 Inhib.	2.3.2	
Gn P/F Highset 2 Inhib.	2.3.2	
Gn E/F Charact. Inhib.	2.3.1	
Gn E/F Lowset Inhib.	2.3.2	
Gn E/F HighSet 1 Inhib.	2.3.2	
Gn E/F HighSet 2 Inhib.	2.3.2	
Gn [SEF/REF] Delay 1 Inhib.	2.4	
Gn [SEF/REF] Delay 2 Inhib.	2.4	
Gn [SEF/REF] Lowset Inhib.	2.4	
Gn Trip Circuit Fail	2.10	
Gn Waveform Trig	2.13.3	
Gn $\Sigma I^2$ Update	2.14.1	
Gn Reset Flag & Output	2.11	
Gn Clock Sync.	2.2.7	

Setting name	Ref	Applied value
Gn Status 1 P/U Delay	2.11	sec
Gn Status 1 D/O Delay	2.11	sec
Gn Status 2 P/U Delay	2.11	sec
Gn Status 2 D/O Delay	2.11	sec
Gn Status 3 P/U Delay	2.11	sec
Gn Status 3 D/O Delay	2.11	sec
Gn Status 4 P/U Delay	2.11	sec
Gn Status 4 D/O Delay	2.11	sec
Gn Status 5 P/U Delay	2.11	sec
Gn Status 5 D/O Delay	2.11	sec
Gn Status 6 P/U Delay	2.11	sec
Gn Status 6 D/O Delay	2.11	sec
Gn Status 7 P/U Delay	2.11	sec
Gn Status 7 D/O Delay	2.11	sec
Gn Status 8 P/U Delay	2.11	sec
Gn Status 8 D/O Delay	2.11	sec
Gn Status 9 P/U Delay	2.11	sec
Gn Status 9 D/O Delay	2.11	sec
Gn ARC Status A	2.9.1	
Gn ΔTrip Counter Reset	2.14.1	
Gn Counter Reset	2.14.1	
Gn FOC Reset	2.14.1	
Gn Trip & ARC	2.9.2	
Gn Close & Lockin	2.9.2	
Gn Trip & Lockout	2.9.2	
Gn Local Close & Reclaim	2.9.2	
Gn Remote Close Reclaim	2.9.2	
Gn CB Open	2.9.1	
Gn CB Closed	2.9.1	
Gn Reclose Block	2.8.1	
Gn P/F ARC Off	2.9.1	
Gn E/F ARC Off	2.9.1	
Gn [SEF/REF] ARC Off	2.9.1	

Setting name	Ref	Applied value
Gn Hot Line Working	2.9.4	
Gn Alarm 1 * see note below	2.2.5	
Gn Alarm 2 * see note below	2.2.5	
Gn Alarm 3 * see note below	2.2.5	
Gn Alarm 4 * see note below	2.2.5	
Gn Alarm 5 * see note below	2.2.5	

\* The text of these setting names reflects the value applied to the 'Set Alarm n' settings in the 'System Config.' menu.

**Comms Interface Menu**

Setting name	Ref	Applied value
Comms Baud Rate	4.3.1	baud
Comms Parity	4.3.2	
Relay Address	4.3.3	
Line Idle	4.3.4	
Data Echo	4.3.5	

**Data Storage Menu**

Setting name	Ref	Applied value
Gn Fault Trigger	2.13.2	
Gn Waveform Trig	2.13.3	
Gn Waveform Pre-Trigger	2.13.3	%
Clear All Waveforms	2.13.3	
Clear All Events	2.13.1	
Clear All Faults	2.13.2	

**CB Maintenance Menu**

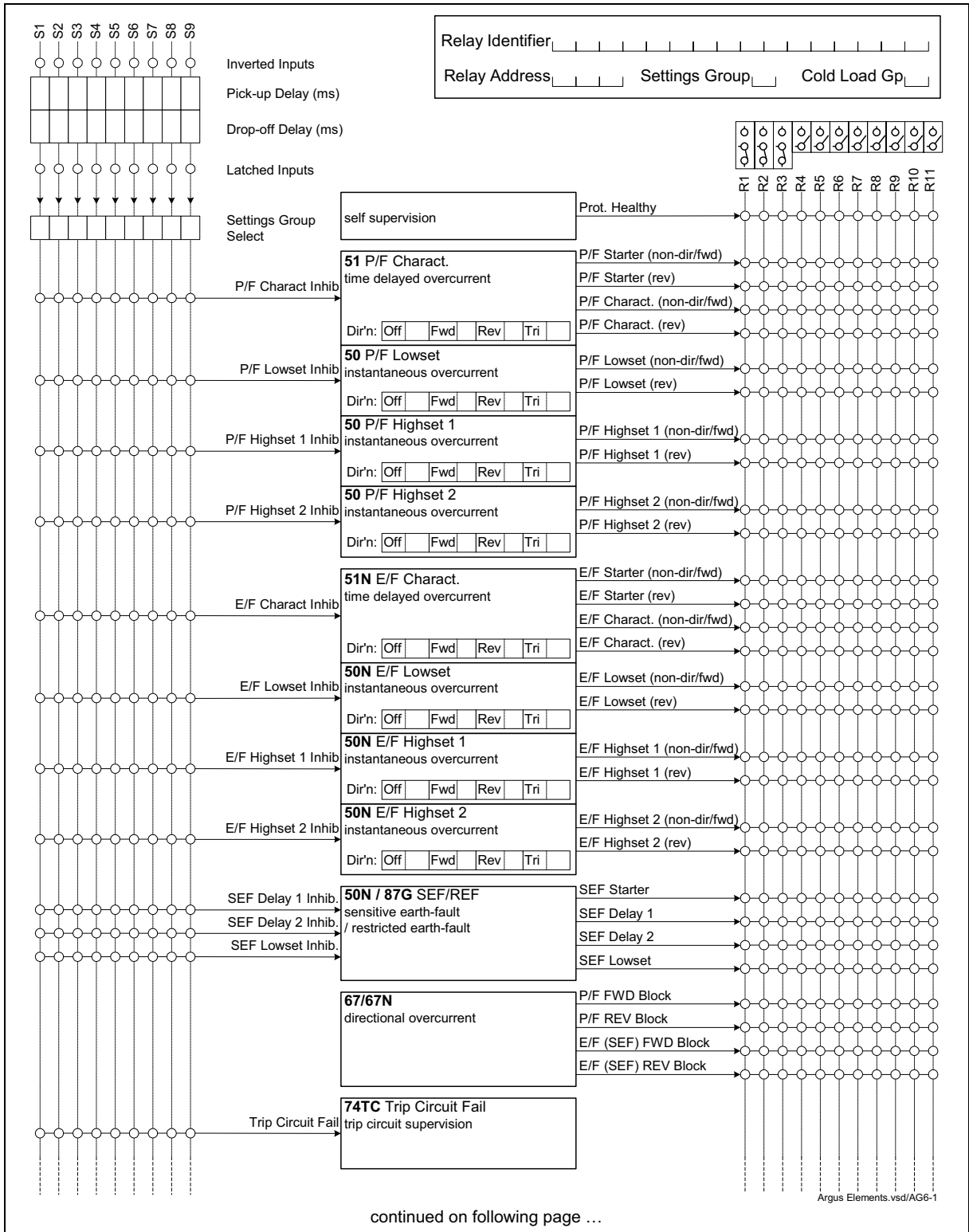
Setting name	Ref	Applied value
Δ Trip Counter Reset	2.14.1	
Δ Trip Counter Alarm	2.14.1	
Trip Counter Reset	2.14.1	
Trip Counter Alarm	2.14.1	
Freq Op Counter Reset.	2.14.1	
Freq Op Counter Alarm	2.14.1	
ΣI <sup>2</sup> Reset	2.14.1	
ΣI <sup>2</sup> Alarm	2.14.1	
Power On Count Reset	2.14.3	

<u>Setting name</u>	<u>Ref</u>	<u>Applied value</u>
Power On Count Alarm	2.14.3	
O/P Relay Test	2.14.2	

**Linesman Menu**

<u>Setting name</u>	<u>Ref</u>	<u>Applied value</u>
Scada Control	2.15	
Hot Line Working	2.15	
Trip & Lockout	2.15	

<u>Setting name</u>	<u>Ref</u>	<u>Applied value</u>
Trip & Reclose	2.15	
Close & Reclaim	2.15	
ARC	2.15	
Inst. Lowset	2.15	
Trip Counter Reset	2.15	
SEF	2.15	



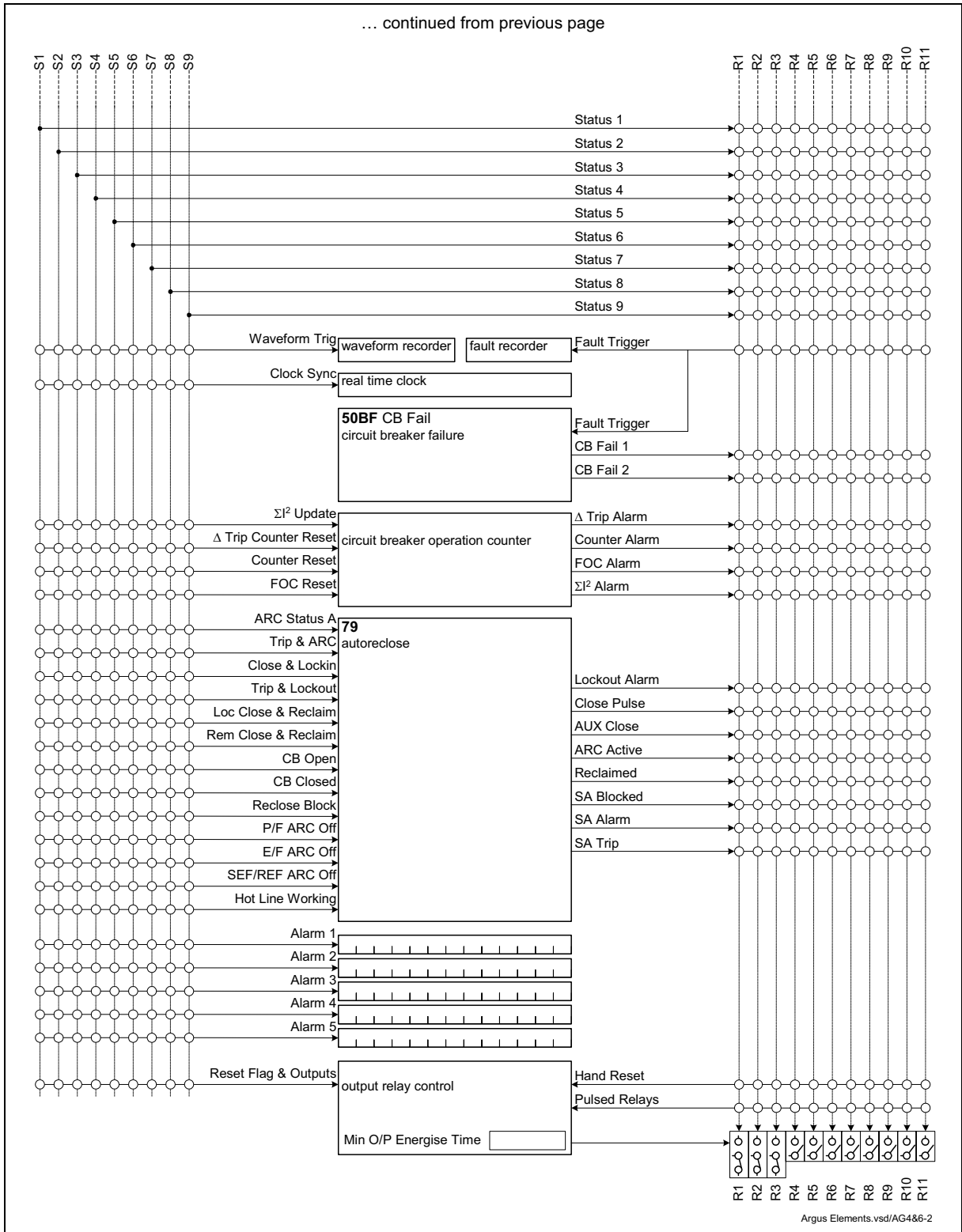


Figure 2-1 Status Input and Output Relay Programming Matrix

## Section 3: IEC 60870-5-103 Definitions

The following tables give information on the IEC 60870-5-103 protocol. A detailed description of all protocol information is available in report no 434/TM/5/13 which can be accessed on the [www.reyrolle-protection.com](http://www.reyrolle-protection.com) in publications section under technical reports, "communications interface manual".

**Table Showing Function Type Numbers Used**

Function Type	Description
160	IEC Overcurrent Protection
164	Reyrolle Overcurrent Protection
254	IEC Generic
255	IEC Global

### Cause of Transmission

The cause of transmission (COT) column of the 'Information Number and Function' table lists possible causes of transmission for these frames. The following abbreviations are used:

**Table Showing Permitted Cause of Transmission Numbers**

Cause of Transmission (COT)	Description
1	Spontaneous Events
2	Cyclic
3	Reset Frame Count Bit (FCB)
4	Reset Communication Unit (CU)
5	Start Restart
6	Power On
7	Test Mode
8	Time Synchronisation
9	General Interrogation
10	Termination of General Interrogation
11	Local Operation
12	Remote Operation
20	Positive Command Acknowledge
21	Negative Command Acknowledge
31	Transmission of Disturbance Data

### Information Number and Function

The following tables list information number and function definitions together with a description of the message and function type and cause of transmission that can result in that message. Not all definitions are available on all relay types – this is dependent on functionality

<b>KEY</b>	<b>FUN</b>	Function Type (defined in IEC60870-5-103 section 7.2.5.1)
	<b>INF</b>	Information Number (defined in IEC60870-5-103 section 7.2.5.2)
	<b>TYP</b>	ASDU Type (defined in IEC60870-5-103 sections 7.3.1 and 7.3.2)
	<b>GI</b>	Event supports General Interrogation x = supported (defined in IEC60870-5-103 section 7.2.5.2)
	<b>COM</b>	Type of command single (ON only) or double (ON/OFF) (defined in IEC60870-5-103 section 7.2.5.2)
	<b>COT</b>	Cause of Transmission (defined in IEC60870-5-103 section 7.2.3, table 5)
	<b>DIR</b>	Direction of event - Raised Only (RO), Raised/Cleared (RC) or Double Point Travelling, Cleared, Raised or Unknown (DBI)
	<b>x</b>	Supported, - Not supported.



Table Showing Command Information (INF) Numbers

FUN	INF	Description	GI	TYP	COT	DIR	Argus 6
160	2	Reset FCB	-	5	3	RO	x
160	3	Reset CU	-	5	4	RO	x
160	4	Start/Restart	-	5	5	RO	x
160	5	Power On	-	5	6	RO	x
160	16	ARC in progress	x	1	1, 9, 12, 20, 21	RC	x
160	19	LEDs reset	-	1	1, 7, 11, 12, 20, 21	RO	x
160	21	Trip Test	x	1	1, 9	RC	x
160	22	Settings changed	x	1	1, 9, 11, 12	RC	x
160	23	Setting G1 selected	x	1	1, 9, 11, 12, 20, 21	RC	x
160	24	Setting G2 selected	x	1	1, 9, 11, 12, 20, 21	RC	x
160	25	Setting G3 selected	x	1	1, 9, 11, 12, 20, 21	RC	x
160	26	Setting G4 selected	x	1	1, 9, 11, 12, 20, 21	RC	x
160	27	Input 1	x	1	1, 9	RC	x
160	28	Input 2	x	1	1, 9	RC	x
160	29	Input 3	x	1	1, 9	RC	x
160	30	Input 4	x	1	1, 9	RC	x
160	36	Trip circuit fail	x	1	1, 9	RC	x
160	46	Group Warning	x	1	1, 9	RC	x
160	47	Alarm	x	1	1, 9	RO	x
160	64	A-starter	x	2	1, 9	RC	x
160	65	B-starter	x	2	1, 9	RC	x
160	66	C-starter	x	2	1, 9	RC	x
160	67	E-starter	x	2	1, 9	RC	x
160	68	General trip	-	2	1	RO	x
160	69	A-general trip	-	2	1	RO	x
160	70	B-general trip	-	2	1	RO	x
160	71	C-general trip	-	2	1	RO	x
160	84	General starter	x	2	1, 9	RC	x
160	85	Circuit breaker fail 1	-	2	1	RO	x
160	91	P/F-general HS trip	-	2	1	RO	x
160	92	E/F-general trip	-	2	1	RO	x

FUN	INF	Description	GI	TYP	COT	DIR	Argus 6
160	93	E/F-general HS trip	-	2	1	RO	x
160	128	CB on by auto reclose	-	1	1	DP	x
160	130	Reclose blocked	x	1	1, 9	RC	x
160	144	Measurand $I_{L1}$ <sup>1</sup>	-	3.1	2,7	-	x
160	148	Measurand $I_{L1,2,3}, {}^1V_{L1,2,3}, P, Q$	-	9	2,7	-	
164	0	Data lost	-	1	1	RO	x
164	1	A-lowset starter	-	2	1	RC	x
164	2	B-lowset starter	-	2	1	RC	x
164	3	C-lowset starter	-	2	1	RC	x
164	4	E-lowset starter	-	2	1	RC	x
164	5	A-lowset trip	-	2	1	RO	x
164	6	B-lowset trip	-	2	1	RO	x
164	7	C-lowset trip	-	2	1	RO	x
164	8	E-lowset trip	-	2	1	RO	x
164	9	A-delayed trip	-	2	1	RO	x
164	10	B-delayed trip	-	2	1	RO	x
164	11	C-delayed trip	-	2	1	RO	x
164	12	E-delayed trip	-	2	1	RO	x
164	13	A-HS1 trip	-	2	1	RO	x
164	14	B-HS1 trip	-	2	1	RO	x
164	15	C-HS1 trip	-	2	1	RO	x
164	16	E-HS1 trip	-	2	1	RO	x
164	17	A-HS2 trip	-	2	1	RO	x
164	18	B-HS2 trip	-	2	1	RO	x
164	19	C-HS2 trip	-	2	1	RO	x
164	20	E-HS2 trip	-	2	1	RO	x
164	21	SEF/REF starter	x	2	1, 9	RC	x
164	23	SEF/REF lowset trip	-	2	1	RC	x
164	24	SEF/REF stage 1 trip	-	2	1	RC	x
164	25	SEF/REF stage 2 trip	-	2	1	RC	x
164	26	A-HS1 starter	-	2	1	RC	x
164	27	B-HS1 starter	-	2	1	RC	x
164	28	C-HS1 starter	-	2	1	RC	x

<sup>1</sup> Current Measurand Scaling can be User set to either 1.2 x In or 2.4 x In

FUN	INF	Description	GI	TYP	COT	DIR	Argus 6
164	29	E-HS1 starter	-	2	1	RC	x
164	30	A-HS2 starter	-	2	1	RC	x
164	31	B-HS2 starter	-	2	1	RC	x
164	32	C-HS2 starter	-	2	1	RC	x
164	33	E-HS2 starter	-	2	1	RC	x
164	34	Circuit breaker open	x	1	1, 9	RO	x
164	35	Setting G5 selected	x	1	1, 9, 11, 12, 20, 21	RC	x
164	36	Setting G6 selected	x	1	1, 9, 11, 12, 20, 21	RC	x
164	37	Setting G7 selected	x	1	1, 9, 11, 12, 20, 21	RC	x
164	38	Setting G8 selected	x	1	1, 9, 11, 12, 20, 21	RC	x
164	39	Circuit breaker fail 2	-	2	1	RO	x
164	41	CB close fail	x	1	1, 9	RO	x
164	43	CB DBI state	x	1	1, 9	RO	x
164	44	External Trip	-	2	1	RO	x
164	45	Input 5	x	1	1, 9	RC	x
164	46	Input 6	x	1	1, 9	RC	x
164	47	Input 7	x	1	1, 9	RC	x
164	48	Input 8	x	1	1, 9	RC	x
164	49	Input 9	x	1	1, 9	RC	x
164	51	Output 1	x	1	1, 9, 12, 20, 21	RC	x
164	52	Output 2	x	1	1, 9, 12, 20, 21	RC	x
164	53	Output 3	x	1	1, 9, 12, 20, 21	RC	x
164	54	Output 4	x	1	1, 9, 12, 20, 21	RC	x
164	55	Output 5	x	1	1, 9, 12, 20, 21	RC	x
164	56	Output 6	x	1	1, 9, 12, 20, 21	RC	x
164	57	Output 7	x	1	1, 9, 12, 20, 21	RC	x
164	58	Output 8	x	1	1, 9, 12, 20, 21	RC	
164	59	Output 9	x	1	1, 9, 12, 20, 21	RC	
164	60	Output 10	x	1	1, 9, 12, 20, 21	RC	
164	61	Output 11	x	1	1, 9, 12, 20, 21	RC	
164	62	Forward A	x	2	1, 9	RC	x
164	63	Reverse A	x	2	1, 9	RC	x
164	64	Forward B	x	2	1, 9	RC	x
164	65	Reverse B	x	2	1, 9	RC	x
164	66	Forward C	x	2	1, 9	RC	x
164	67	Reverse C	x	2	1, 9	RC	x
164	68	Forward E	x	2	1, 9	RC	x
164	69	Reverse E	x	2	1, 9	RC	x

FUN	INF	Description	GI	TYP	COT	DIR	Argus 6
164	70	Trip count alarm	x	1	1, 9	RC	x
164	70	Trip count alarm	x	4	1, 9	RC	
164	71	CB maintenance alarm	x	1	1, 9	RC	x
164	71	CB maintenance alarm	x	4	1, 9	-	
164	72	Frequent operations exceeded	x	1	1, 9	RC	x
164	73	Delta Trip Counter Alarm	x	1	1, 9	RC	x
164	79	Voltage Block	x	1	1, 9	RC	
164	80	Waveform stored	-	1	1, 12, 20, 21	RO	x
164	81	Remote control interrupted	-	1	1	RO	x
164	82	Trip and Lockout	-	1	1, 12, 20, 21	RO	x
164	83	Close and Reclaim	-	1	1, 12, 20, 21	RO	x
164	84	Trip And Reclose	-	1	1, 12, 20, 21	RO	x
164	85	Circuit breaker closed	x	1	1, 9	RO	x
164	86	Close And Lockin	-	1	1, 12, 20, 21	RO	x
164	87	Reclose delay	x	1	1, 9	RC	x
164	88	Reclaim	x	1	1, 9	RC	x
164	89	Lockout	x	1	1, 9	RC	x
164	90	Forward SEF	x	2	1, 9	RC	x
164	91	Reverse SEF	x	2	1, 9	RC	x
164	92	Power On Counter Alarm	x	1	1, 9	RC	x
164	97	CT Failure	x	1	1, 9	RC	
164	100	Cold load pickup	x	1	1, 9, 12, 20, 21	RC	x
164	101	Cold load trip	-	2	1	RO	x
164	102	Line check trip	-	2	1	RO	x
164	103	ARC start A	x	1	1, 9	RC	x
164	104	A backup time	-	1	1	RC	x
164	105	A backup trip	-	1	1	RC	x
164	106	External trip block	x	1	1, 9	RC	x
164	110	SEF off	x	1	1, 9, 12, 20, 21	RC	x
164	111	All ARC off	x	1	1, 9	RC	x
164	112	P/F ARC off	x	1	1, 9, 12, 20, 21	RC	x
164	113	E/F ARC off	x	1	1, 9, 12, 20, 21	RC	x
164	114	SEF ARC off	x	1	1, 9, 12, 20, 21	RC	x
164	115	All inst off	x	1	1, 9, 12, 20, 21	RC	x
164	116	P/F inst off	x	1	1, 9, 12, 20, 21	RC	x
164	117	E/F inst off	x	1	1, 9, 12, 20, 21	RC	x

FUN	INF	Description	GI	TYP	COT	DIR	Argus 6
164	118	SEF inst off	x	1	1, 9, 12, 20, 21	RC	x
164	119	Hot line working	x	1	1, 9, 12, 20, 21	RC	x
164	120	Scada Control	x	1	1, 9	RC	x
164	121	General alarm 1	x	1	1, 9	RC	x
164	122	General alarm 2	x	1	1, 9	RC	x
164	123	General alarm 3	x	1	1, 9	RC	x
164	124	General alarm 4	x	1	1, 9	RC	x
164	125	General alarm 5	x	1	1, 9	RC	x
164	131	Va/Vab starter	x	2	1, 9	RC	
164	132	Vb/Vbc starter	x	2	1, 9	RC	
164	133	Vc/Vca starter	x	2	1, 9	RC	
164	170	V starter	x	2	1, 9	RC	
164	182	V trip	-	2	1	RO	
164	190	Voltage Memory A	x	1	1, 9	RC	
164	191	Voltage Memory B	x	1	1, 9	RC	
164	192	Voltage Memory C	x	1	1, 9	RC	
164	240	Ia Fault Current	x	4	1, 9	-	
164	241	Ib Fault Current	x	4	1, 9	-	
164	242	Ic Fault Current	x	4	1, 9	-	
164	243	Ie Fault Current	x	4	1, 9	-	
164	244	Isef Fault Current	x	4	1, 9	-	
164	245	Va Fault Voltage	x	4	1, 9	-	
164	246	Vb Fault Voltage	x	4	1, 9	-	
164	247	Vc Fault Voltage	x	4	1, 9	-	
164	248	Vn Fault Voltage	x	4	1, 9	-	
255	0	Time Synchronisation	-	6	8	-	x
255	0	End of General Interrogation	-	8	10	-	x

Table Showing Command Information (INF) Numbers

FUN	INF	Description	COM	TYP	COT	Argus 6
160	16	Auto-recloser ON/OFF	ON/OFF	20	20	x
160	19	Reset Flag & Outputs	ON	20	20	x

FUN	INF	Description	COM	TYP	COT		Argus 6
160	23	Settings Group 1 Select	ON	20	20		x
160	24	Settings Group 2 Select	ON	20	20		x
160	25	Settings Group 3 Select	ON	20	20		x
160	26	Settings Group 4 Select	ON	20	20		x
164	35	Settings Group 5 Select	ON	20	20		x
164	36	Settings Group 6 Select	ON	20	20		x
164	37	Settings Group 7 Select	ON	20	20		x
164	38	Settings Group 8 Select	ON	20	20		x
164	51	Energise Output 1	ON	20	20		x
164	52	Energise Output 2	ON	20	20		x
164	53	Energise Output 3	ON	20	20		x
164	54	Energise Output 4	ON	20	20		x
164	55	Energise Output 5	ON	20	20		x
164	56	Energise Output 6	ON	20	20		x
164	57	Energise Output 7	ON	20	20		x
164	58	Energise Output 8	ON	20	20		
164	59	Energise Output 9	ON	20	20		
164	60	Energise Output 10	ON	20	20		
164	61	Energise Output 11	ON	20	20		
164	80	Trigger Waveform Storage	ON	20	20		x
164	82	Trip and Lockout	ON	20	20		x
164	83	Close and Reclaim	ON	20	20		x
164	84	Trip And Reclose	ON	20	20		x
164	86	Close And Lockin	ON/OFF	20	20		x
164	100	Cold load pickup	ON/OFF	20	20		x
164	110	SEF	ON/OFF	20	20		x
164	112	P/F ARC Inhibit	ON/OFF	20	20		x
164	113	E/F ARC Inhibit	ON/OFF	20	20		x
164	114	SEF ARC Inhibit	ON/OFF	20	20		x
164	115	Instantaneous	ON/OFF	20	20		x
164	116	P/F Instantaneous	ON/OFF	20	20		x
164	117	E/F Instantaneous	ON/OFF	20	20		x
164	118	SEF Instantaneous	ON/OFF	20	20		x

FUN	INF	Description	COM	TYP	COT		Argus 6
164	119	Hot line working	ON/OFF	20	20		x
164	129	Reset Energy Meters	ON/OFF	20	20		
164	130	Reset Maximum Demand	ON/OFF	20	20		x
255	0	Initiate General Interrogation	-	7	9	-	x
255	0	Time Synchronisation	-	6	8		x

**Note:** Events listed as responding to a General Interrogation (**GI**) will be raised and cleared (**RC**); other events are raised only (**RO**) and do not respond to a **GI**.

### Section 4: Application Diagrams

The following pages contain example application diagrams for a variety of connections, showing various hardware options.

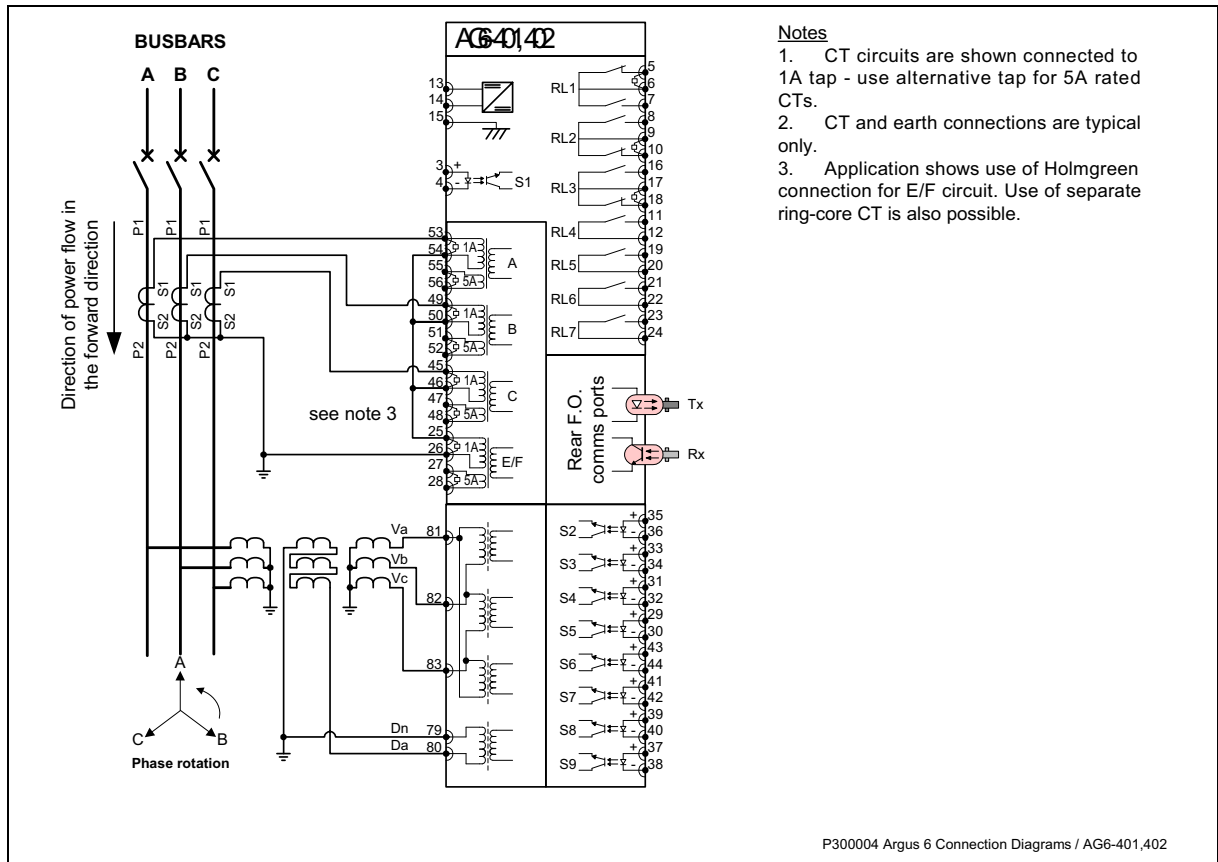


Figure 4-1 Typical Connection for 3 Directional Phase-fault and Directional Earth-fault

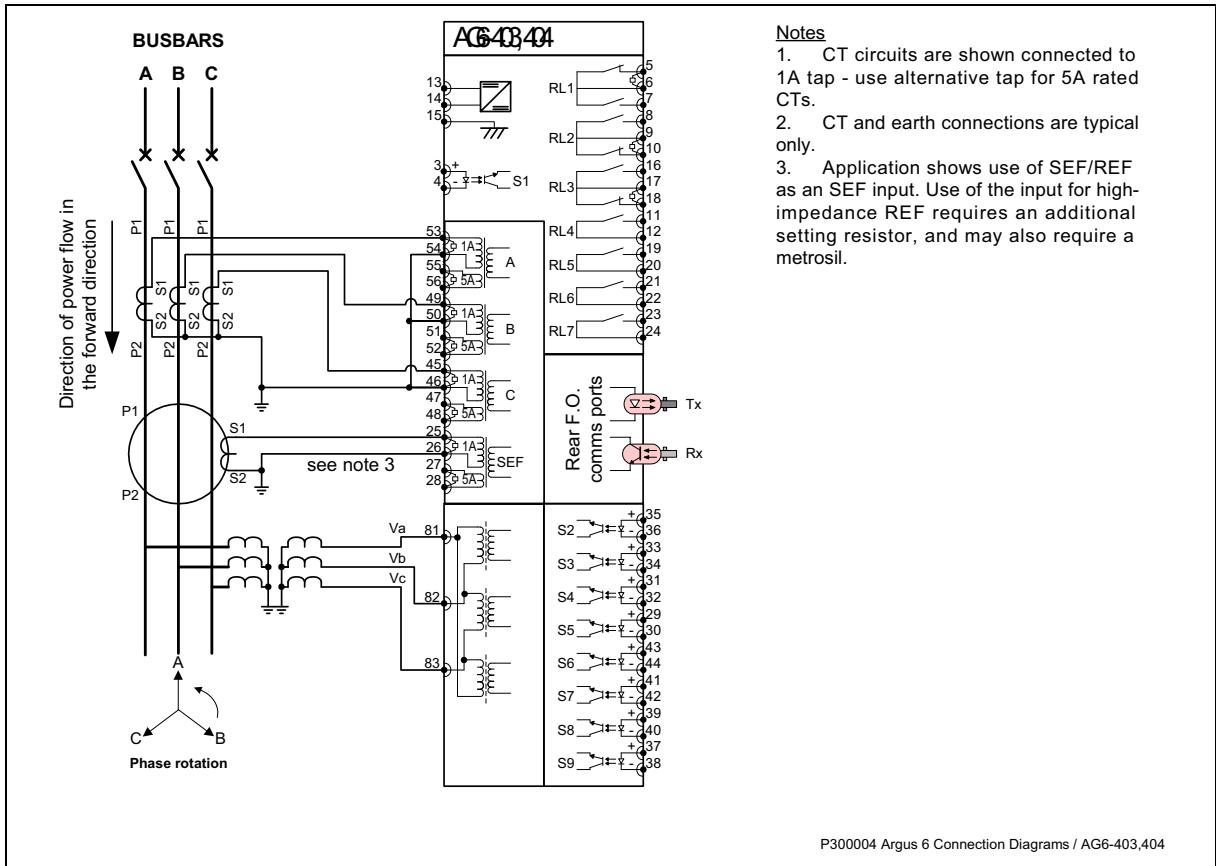


Figure 4-2 Typical Connection for 3 Directional Phase-fault and Sensitive Earth-fault

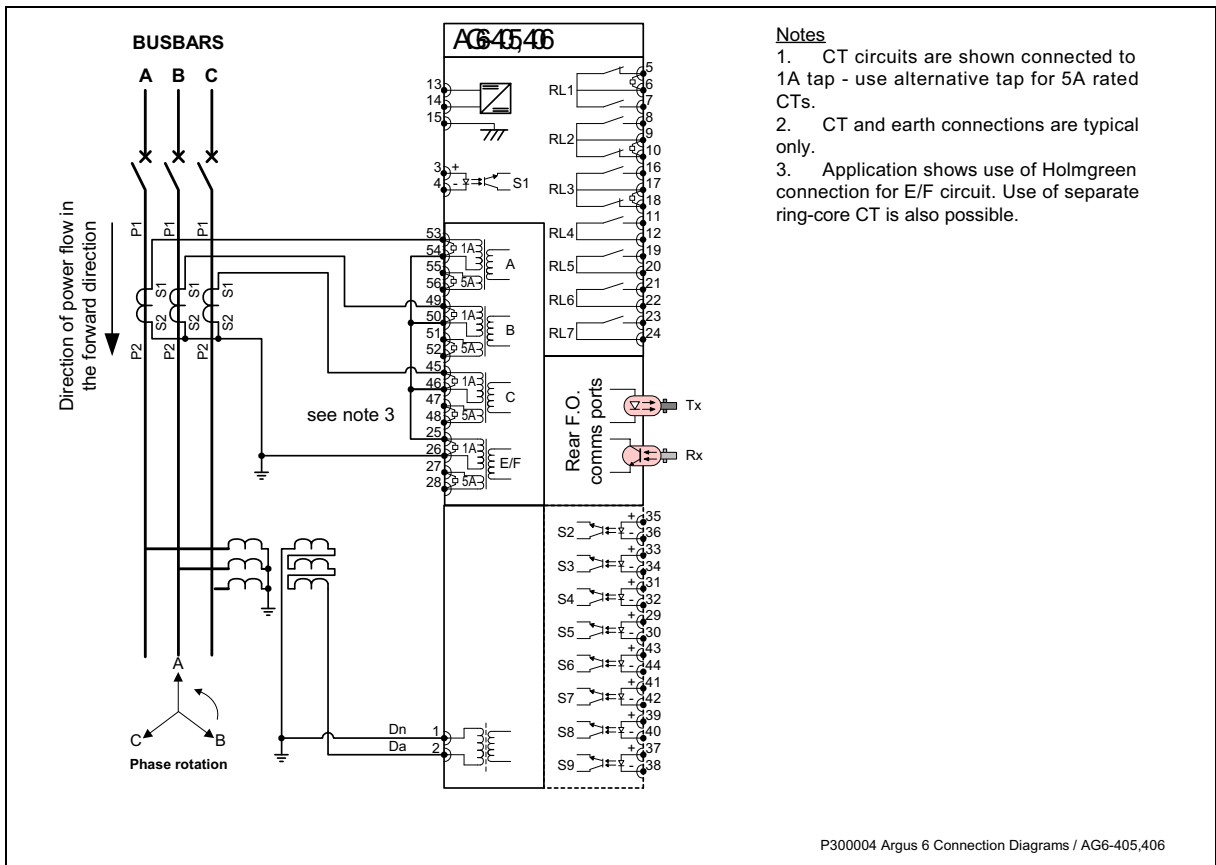


Figure 4-3 Typical Connection for 3 Phase-fault and Directional Earth-fault Protection

**Notes**

1. CT circuits are shown connected to 1A tap - use alternative tap for 5A rated CTs.
2. CT and earth connections are typical only.
3. Application shows use of SEF/REF as an SEF input. Use of the input for high-impedance REF requires an additional setting resistor, and may also require a metrosil.

**Notes**

1. CT circuits are shown connected to 1A tap - use alternative tap for 5A rated CTs.
2. CT and earth connections are typical only.
3. Application shows use of Holmgreen connection for E/F circuit. Use of separate ring-core CT is also possible.



Siemens Protection Devices Limited  
P.O. Box 8  
North Farm Road  
Hebburn  
Tyne & Wear  
NE31 1TZ  
United Kingdom  
Phone: +44 (0)191 401 7901  
Fax: +44 (0)191 401 5575  
Web: [www.siemens.com/energy](http://www.siemens.com/energy)

PTD 24h Customer Support  
Phone: +49 180 524 7000  
Fax: +49 180 524 2471  
E-mail: [support.energy@siemens.com](mailto:support.energy@siemens.com)  
Data is subject to change without notification.

[www.siemens.com/energy](http://www.siemens.com/energy)