



ELIS PLZEŇ a. s.

Product application, installation and service manual

FLOMIC FL 3005 – battery-powered ultrasonic flow meter
for direct installation in piping

Page 1 of 40

***Battery-powered ultrasonic flow meter
for direct installation in piping***

FLOMIC FL 3005





Contents

1. APPLICATION	3
2. FUNCTION PRINCIPLE	3
3. TECHNICAL DESCRIPTION	4
3.1. Terminology and symbols used in this manual.....	4
3.2. Meter description	5
3.3. Meter design.....	9
3.3.1. <i>Flow meter sensor</i>	9
3.3.2. <i>Electronic unit UP 8.00</i>	9
4. TECHNICAL PARAMETERS	9
4.1. Flow velocity determination	9
4.2. Technical specifications	10
5. GENERAL RULES FOR FLOW METER APPLICATION	11
6. FLOW METER INSTALLATION	13
6.1. Meter assembly and installation principles	13
6.1.1. <i>Recommended assembly fixtures and tooling</i>	14
6.1.2. <i>Flow meter installation criteria</i>	14
6.1.2.1. Measuring spot selection.....	14
6.1.2.2. Necessary room for flow sensor installation	15
6.1.3. <i>Preparatory and measuring operations on meter piping</i>	15
6.1.3.1. Determination of OD of meter piping	15
6.1.3.2. Marking of top surface line	16
6.1.3.3. Laying out of installation points	16
6.1.4. <i>Fitting welded-on pieces into meter piping</i>	18
6.1.5. <i>Facing of seating surfaces on welded-on pieces</i>	21
6.1.6. <i>Determination of mechanical parameters of the meter sensor</i>	22
6.1.6.1. Measuring ray angle.....	22
6.1.6.2. Distance between the outer-end faces of welded-on pieces.....	23
6.1.6.3. Inner diameter of meter piping.....	23
6.1.7. <i>Flow meter sensor assembly</i>	24
6.1.8. <i>External signal connections</i>	24
7. SETTING FLOW METER IN OPERATION	25
7.1. Theoretical calibration	25
7.2. Description of calibration procedure.....	25
7.2.1. <i>TheoCalc program</i>	26
7.2.2. <i>CaliberFL program</i>	27
7.2.3. <i>Check on zero setting</i>	30
8. METER OPERATION	30
8.1. Reading measured data from display.....	30
8.2. Electrical outputs	31
8.2.1. <i>Impulse output</i>	31
8.2.2. <i>Current output</i>	32
8.3. Communication interface.....	32
8.3.1. <i>Optical interface</i>	32
8.3.2. <i>RS 232 interface</i>	33
8.3.2. <i>M-Bus interface</i>	33
8.4. Communication modes.....	34
8.4.1. <i>Optical probe + personal (notebook) computer</i>	34
8.4.2. <i>RS 232 + personal (notebook) computer</i>	34
8.4.2. <i>RS 232 + GSM module</i>	35
8.5. Error identification	35
8.6. Battery lifetime and replacement.....	36
9. WARRANTY AND POST-WARRANTY SERVICES	37
9.1. Warranty services.....	37
9.2. Post-warranty services	37
10. TESTING	37
11. PACKAGING	37
12. PRODUCT ACCEPTANCE	37
13. WARRANTY TERM AND CONDITIONS	37
14. ORDERING PROCEDURE	38

1. APPLICATION

The FLOMIC battery-powered ultrasonic flow meter of the type series FL 3005 for direct installation into piping is intended for measurements of instantaneous flow rate and of the total volume of water passed through fully flooded piping. The flow meter includes hardware and software for communication with plant control systems.

The FLOMIC FL 3005 meter can be installed into existing steel piping with minimum modifications and relatively low investment costs. The advantages of this solution are particularly evident in the cases of large piping diameter where a flow meter sensor installation between flanges is far more expensive than a system using “direct” sensor mounting.

2. FUNCTION PRINCIPLE

The FLOMIC FL 3005 meter uses a single-channel “transit-time” impulse measuring method where the flow rate as the basic measured parameter is determined from the flight time of the ultrasonic signal between the sensor probes.

The two ultrasonic probes installed into the fluid piping under specified angle operate in turns as a sender and receiver (see Fig. 1).

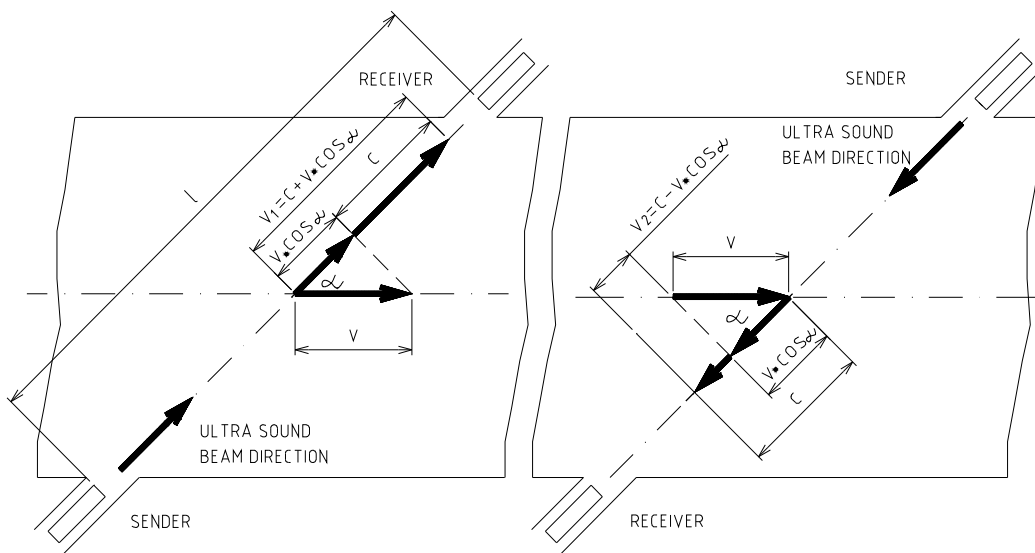

Fig. 1 Principle of flow-rate measurement

It holds that, in the configuration shown in Fig. 1, ultrasonic ray propagates faster in the direction of the flowing fluid than against it. Electronic converter evaluates the differences between the transit (passage) times of ultrasonic waves sent in and against the fluid flow direction, determines the average flow velocity of the fluid and, taking into account the parameters of the meter piping, calculates the value of instantaneous flow rate.

The above principle of flow rate measurement using ultrasonic ray can be described by the following equations:

$$v_1 = c + v \cdot \cos \alpha \quad [1]$$

$$v_2 = c - v \cdot \cos \alpha \quad [2]$$

$$t_1 = \frac{1}{v_1} \quad [3]$$

$$t_2 = \frac{1}{v_2} \quad [4]$$

 ELIS PLZEŇ a. s.	Product application, installation and service manual	Page 4 of 40
	FLOMIC FL 3005 – battery-powered ultrasonic flow meter for direct installation in piping	

where

- v_1 is ultrasonic ray velocity in the direction of fluid flow [m/s]
- v_2 is ultrasonic ray velocity against the direction of fluid flow [m/s]
- t_1 is passage time of ultrasonic ray sent in the fluid flow direction [s]
- t_2 is passage time of ultrasonic ray sent against the fluid flow direction [s]
- c is ultrasonic signal propagation velocity in the measured medium [m/s]
- l is distance between the face parts of ultrasonic probes [m]
- v is instantaneous value of the average velocity of the flowing medium [m/s]
- α is angle formed by the measuring ray and the longitudinal axis of the piping [deg]

After some modifications of equations [1] to [4], the average velocity of the fluid flowing through the piping can be expressed as follows:

$$v = \frac{1(t_2 - t_1)}{2.t_1.t_2.\cos \alpha} \quad [5]$$

For the flow rate it holds:

$$q = v.s.k (v) \quad [6]$$

where

- s is square section of the meter piping [m²]
- $k (v)$ is correction coefficient related to the velocity profile of the fluid flowing through the meter piping

From equations [5] and [6] it follows that the flow rate of the measured medium is independent of either sound propagation velocity in the measured medium or the medium pressure or temperature. The flow rate only depends on the difference between the passage times of the ultrasonic signals sent between the meter probes in and against the fluid flow direction, and on the mechanical arrangement of the flow meter sensor, i.e. its dimensions and physical properties of the construction materials used.

For a flow meter installed directly in the existing piping it is therefore necessary to identify precisely the dimensions and properties of the meter piping section. Upon installation of ultrasonic probes in the piping, all mechanical and physical data on the sensor assembly need be reduced to electronic form and stored in the UP 8.00 electronic control unit for the purposes of the so-called theoretical meter calibration.

3. TECHNICAL DESCRIPTION

3.1. Terminology and symbols used in this manual

Meter piping

Meter piping is a section of technological piping system complying with the requirements for flow meter installation

abbreviated term or symbol
piping

Flow meter sensor

Meter piping section including ultrasonic probes

sensor

Flow-stabilising piping sections

To ensure correct functioning of the flow meter, the flow velocity profile in the meter piping must be stable. This condition is met by locating the flow meter sensor at a spot where there are straight piping sections of sufficient length at the input and output sides of the meter sensor. The required stabilisation length is given in multiples of the internal diameter (ID) of the meter piping.

Top surface line

The top surface line is defined as the section line common to a perpendicular plane including the longitudinal axis of the piping and the outer piping surface.

p_v

Measuring ray

Measuring ray is ultrasonic signal (wave) propagating between the face parts of ultrasonic probes along a line identical with the longitudinal axes of the probes.

ray

Side surface line	p_b
<i>The side surface line is defined as the section line common to a horizontal plane including the longitudinal axis of the piping and the outer piping surface.</i>	
Outer diameter (OD) of the meter piping	D_o
Inner diameter (ID) of the meter piping	D_i
Angle formed by the measuring ray and the longitudinal axis of the meter piping	α
Ultrasonic probe	probe
Welded-on piece used as a holder for the ultrasonic probe	welded-on piece
Welding flange	flange
Rectification (alignment) pin	
Distance between the face parts of ultrasonic probes	l
Distance between the outer-end faces of the welded-on pieces	L
Probe sealing thickness	p
Piping wall thickness	t
Length of the ultrasonic probe body	m

3.2. Meter description

The FLOMIC FL 3005 ultrasonic flow meter is an electronic device for measuring water flow rate in a fully flooded piping. It consists of the battery-powered UP 8.00 electronic control unit and flow meter sensor including two US 2.1 ultrasonic probes. In the standard configuration, the FL 3005 meter is suitable for application in piping of nominal sizes DN 200 to DN 2,000; with angle $\alpha = 45^\circ$ for piping sizes up to DN 800, and with angle $\alpha = 60^\circ$ for larger sizes (see the schematic drawing below):

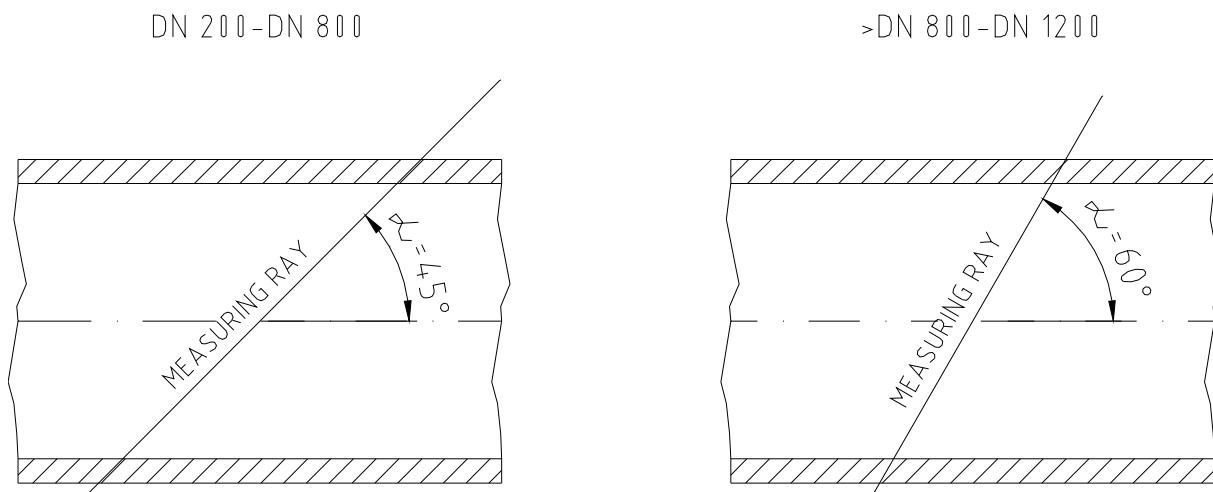

The meter software makes possible determination and display of the instantaneous flow rate values and those of the total fluid volume passed through the meter sensor since the last resetting of the respective counter. The flow meter is provided with a passive optically-isolated impulse output. The standard impulse length is 2ms. On customer's request, the setting can be changed to 40ms. The electronic control unit further includes the RS 232 communication interface.

The flow meter configuration can be extended to include optional features such as passive current output, data archiving memory, M-Bus communication interface, GSM module and optical interface for data reading. On special request, the ultrasonic probes can be supplied in the IP68 version.

The FLOMIC FL 3005 ultrasonic flow meter with ultrasonic probes to be fitted directly in the measured piping consists of the following component parts:

- 1 pc. Electronic control unit (model UP 8.00, see Fig. 2)
- 2 pcs Ultrasonic probe (model US 2.1, see Fig. 3) including coaxial cable; the cable length should be specified in the product order
- 2 pcs Welded-on piece (Fig. 4)
- 2 pcs Welding flange (Fig. 5)
- 2 pcs Probe sealing
- Product application, installation and service manual (Es 90 398 K)
- Theoretical calibration programs (Es 90 470 D and Es 90 499 D)
- User program handbooks (Es 90 316 K and Es 90 318 K)

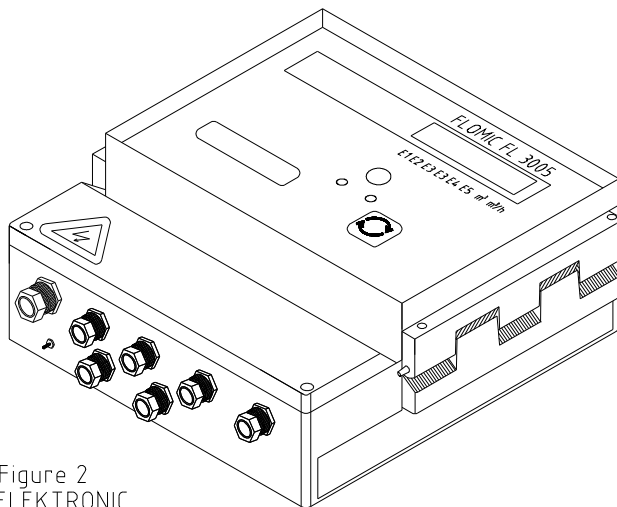

Figure 2
ELÉKTRONIC
CONTROL UNIT

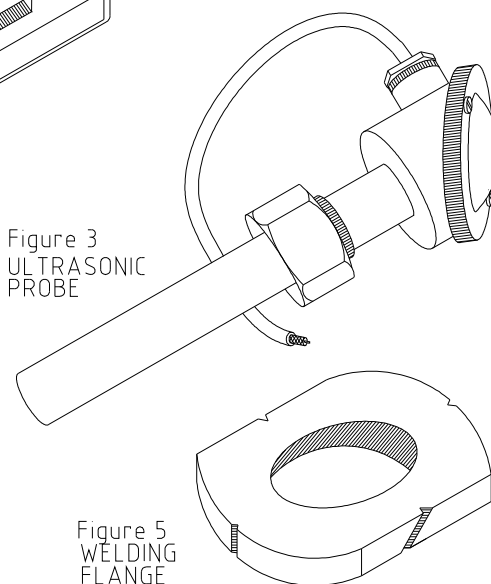

Figure 3
ULTRASONIC
PROBE

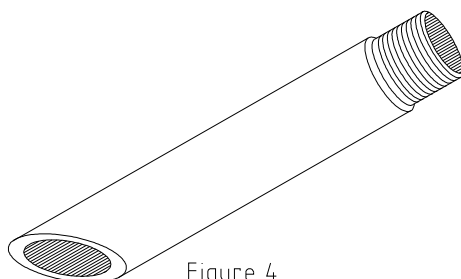

Figure 4
WELDED-ON PIECE

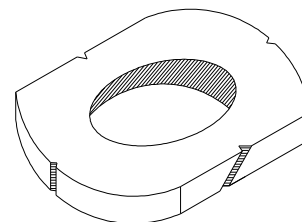
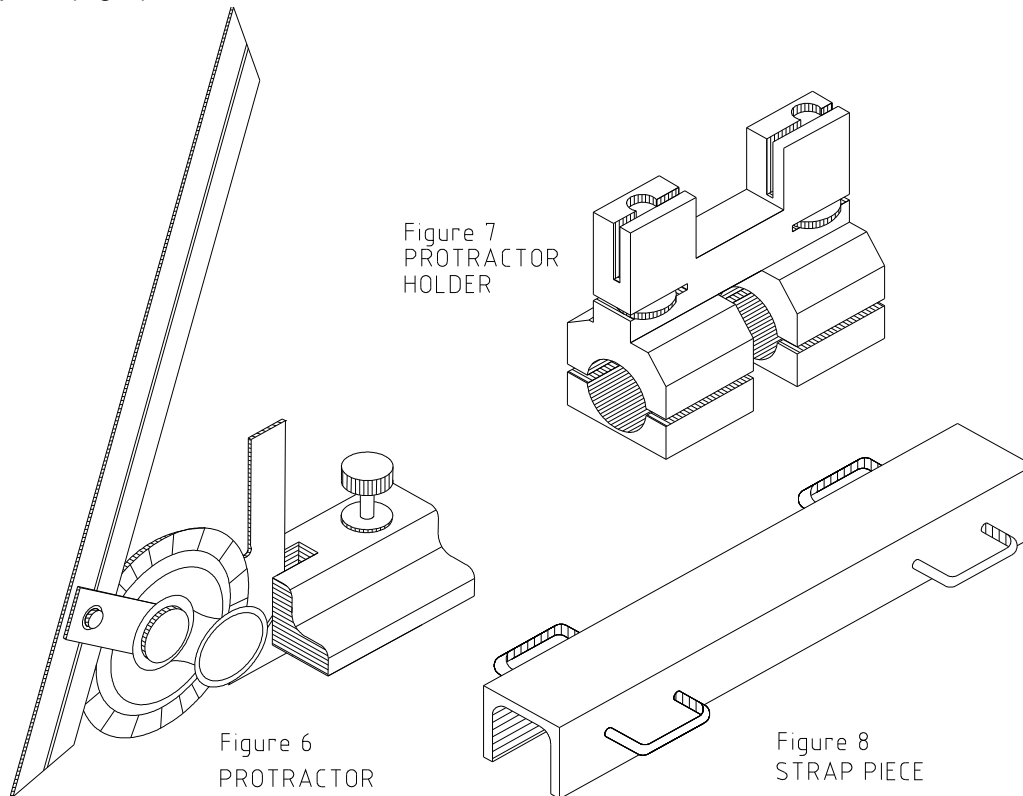

Figure 5
WELDING
FLANGE

In the case of a meter installation by the customer, the delivery kit may include various optional measuring and assembly fixtures, such as:

- 1 pc. Communication cable
- 1 pc. Protractor (Fig. 6)
- 1 pc. Protractor holder (Fig. 7)
- 1 pc. Strap piece (Fig. 8)



- Set of parts associated with the rectification pin:

- 1 pc. Protractor adaptor (Fig. 9)
- 1 pc. Milling adaptor I including milling tool and nut (Fig. 10)
- 1 pc. Milling adaptor II (Fig. 11)

- Set of connecting parts (see Fig. 12) in quantities given in the following table:

Piping size	Connecting part, L = 250	Connecting part, L = 450	Connecting part, L = 850
DN 200	1	-	-
DN 250	1	-	-
DN 300	1	-	-
DN 350	-	1	-
DN 400	-	1	-
DN 500	-	1	-
DN 600	-	-	1
DN 700	-	-	1
DN 800	-	-	1
DN 900	-	-	1
DN 1000	-	-	1
DN 1200	-	1	1
DN 1400	1	1	1
DN 1600	-	2	1
DN 1800	-	1	2
DN 2000	1	1	2

Figure 9

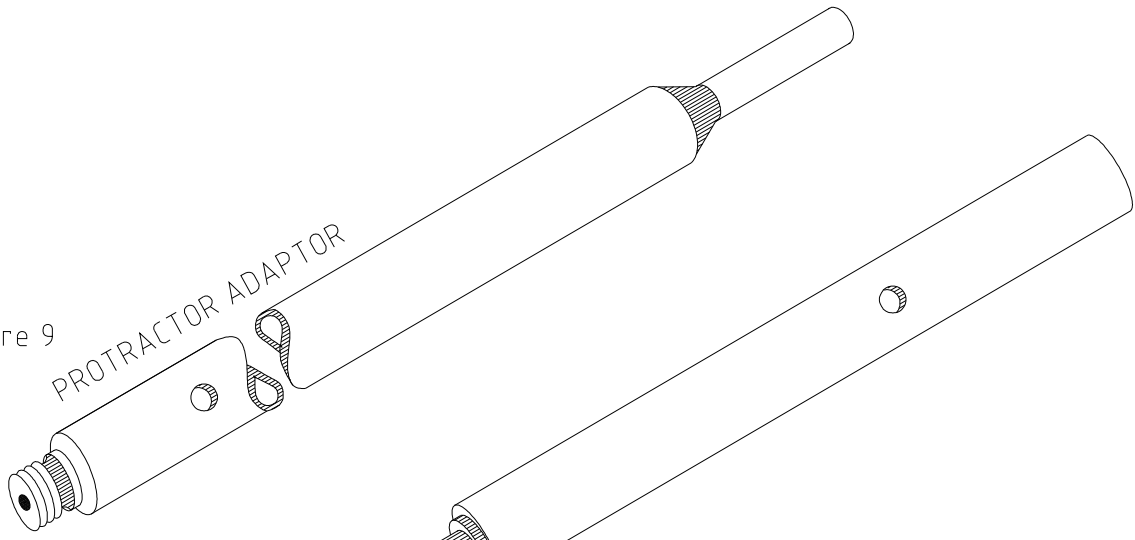

L= 855

Figure 10

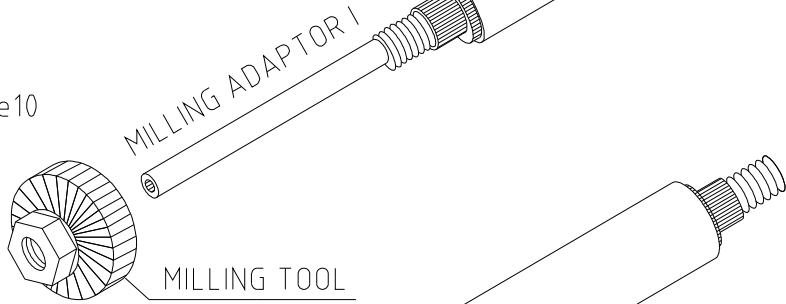

L= 328

Figure 11

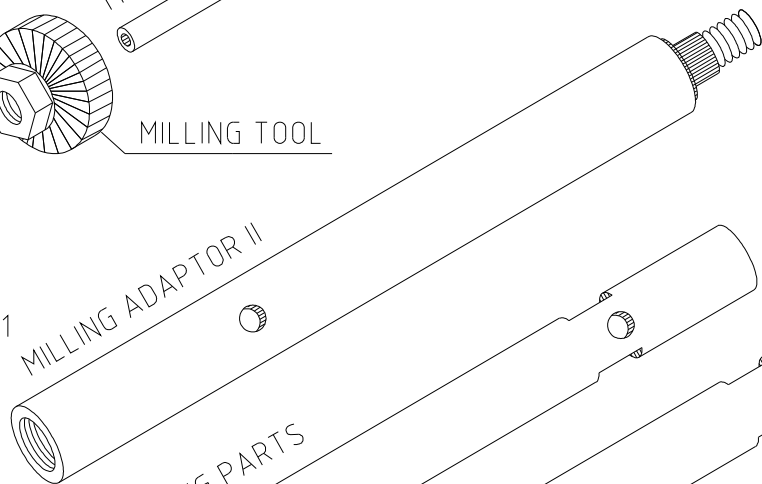

L= 248

Figure 12

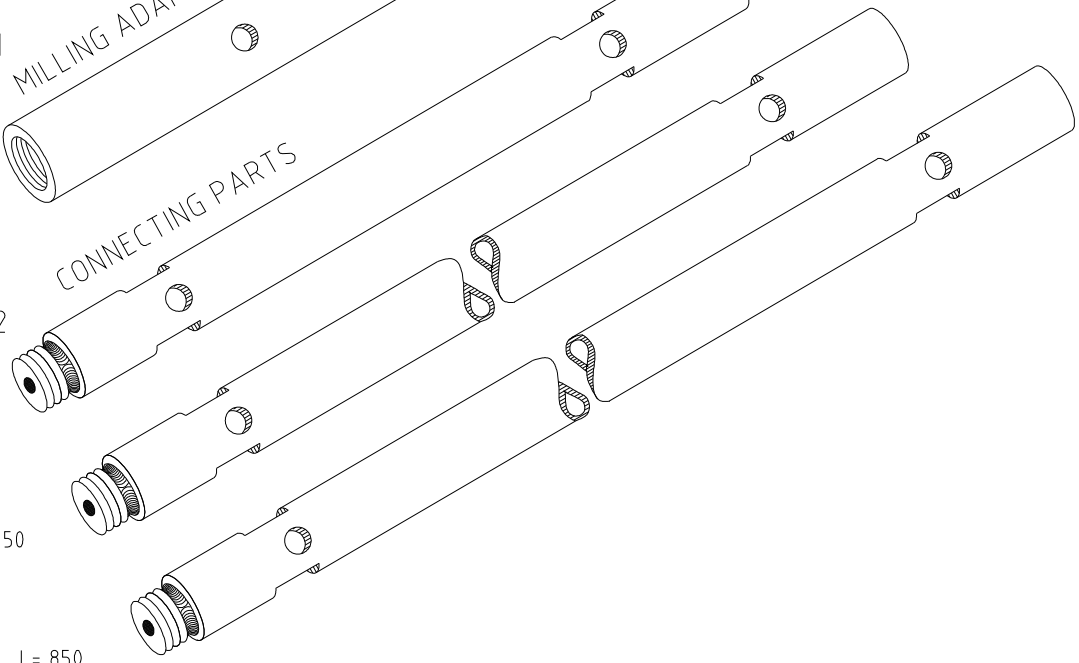

L= 250

L= 450

L= 850

3.3. Meter design

3.3.1. Flow meter sensor

The flow meter sensor assembly consists of the meter piping and ultrasonic probes fitted into it.

3.3.2. Electronic unit UP 8.00

The flow meter control (and signal-processing) unit is accommodated in a plastic box attached to a steel plate designed to be hung on a vertical support plate or wall. On the front panel of the box there are: flow meter name and type designation, production series number, the manufacturer's logo and trade name, back-lighted display unit, membrane push button and optical probe window. At the bottom of the box under a removable lid there are terminals for connecting cables. The bottom wall further includes four PG 7 grommets for cables of circular cross-section and diameters 3 to 6.5mm, and earthing bolt M4. Both the front panel and terminal lid are provided with seals.

CAUTION: Prior to starting the meter operation, make sure that all grommets containing cables are properly tightened and the unused grommets blinded.

CAUTION: When installed in the open air, the box containing electronic unit must be protected against direct sunshine. However, the box must not be placed inside a sealed/unventilated cabinet.

Dimensional sketch of the electronic unit box

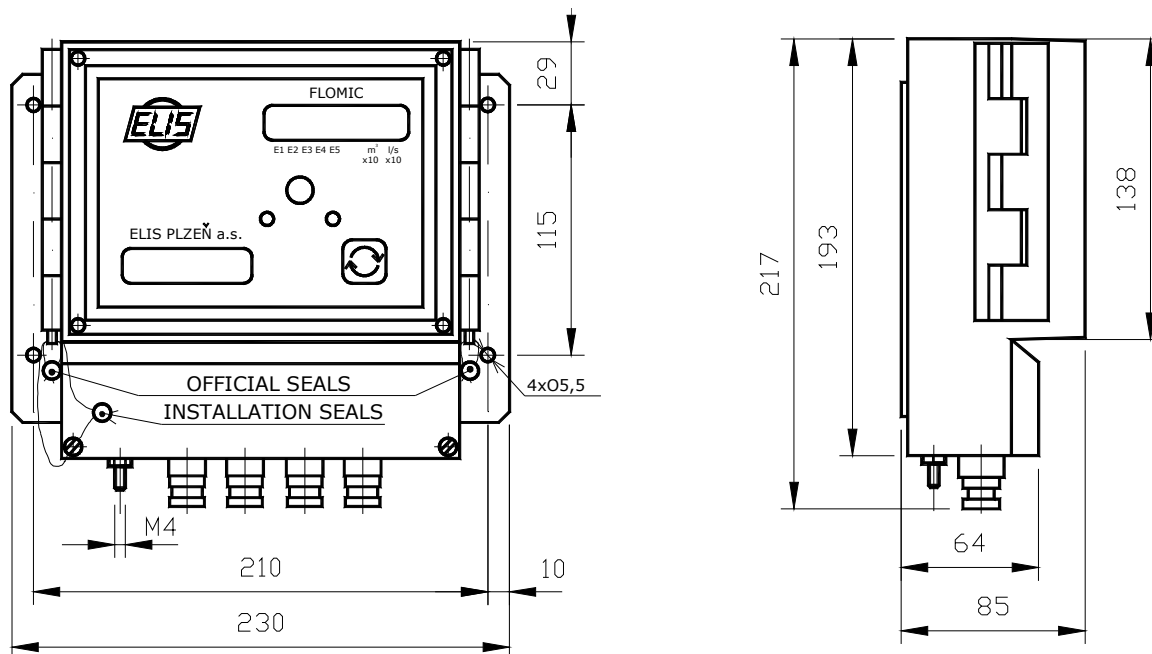

4. TECHNICAL PARAMETERS

4.1. Flow velocity determination

The basic parameter to be ascertained prior to installation of a flow meter is the range of operational flow rate range expected in the given piping.

The flow rate is defined by the following formula:

$$v[m/s] = 353 \cdot \frac{q[m^3/hod]}{D_i^2[mm]}$$

where D_i is ID of the meter piping
 q is measured flow rate
 v is flow velocity

The fluid flow rate in the meter piping must be within the range of 3 to 6 m/s.

4.2. Technical specifications

Piping ID DN	200 to 2,000
Measuring ray angle α	for DN 200 to DN 800 - 45° for DN > 800 to DN 2,000 - 60°
Measurement accuracy	$\pm 2\%$ of the measured flow rate within the range of 5 to 100% q_s (q_s - maximum flow rate at the flow velocity of 6 m/s)
Rated (nominal) pressure of measured fluid PN	max. 40
Temperature of measured fluid	0 to +150°C
Ambient temperature	+5 to +55°C
Ambient humidity	max. relative humidity 80%
Storage temperature	-10 to +70°C at relative humidity not exceeding 70%
Protection class - electronic unit UP 8.00 - ultrasonic probe US 2.1	IP 65 IP 54
Ultrasonic probes	model US 2.1, 2 pieces, manufacturer: ELIS PLZEŇ a.s.
Probe installation	direct fitting into the meter piping (see the product manual)
Connecting cable to probe US 2.1	max. length 20m
Difference in probe cable lengths	Not exceeding 0.1m
Electronic unit UP 8.00 - overall dimensions - weight - power supply	230 x 217 x 85mm 1.5kg 1x Li battery 3.6V / 16.5Ah 2x (or 3x – for DN1,400 to 2,000) alkali batteries 9V / 0.5A Battery lifetime: 4 years
Fluid flow velocity range	3 to 6 m/s
Display unit	8-character LCD
Outputs	passive impulse output $U = 3$ to 30V, $I_{max} = 10$ mA communication interface RS 232
Optional features/accessories	passive current output 4 to 20mA, $U_{max} = 24$ V
	data archiving memory
	archive data reading via GSM module
	optical interface function including optical probe and ArchTerm program
	communication interface M-BUS
	ultrasonic probes with protection class IP 68

Q_{max} and impulse constants (litres per impulse) for particular piping sizes

DN	200	250	300	350	400	450	500	550	600	650	700	750
Q_{max} [m³/h]	600	1000	1500	2000	2500	3500	4500	5000	6000	7000	8000	9000
Imp [l/imp]	500	500	500	1000	1000	1000	2000	2000	2000	5000	5000	5000

DN	800	900	1000	1100	1200	1300	1400	1500	1600	1800	2000
Q_{max} [m³/h]	10000	12000	14000	16000	18000	20000	22000	24000	25000	30000	36000
Imp [l/imp]	5000	10000	10000	10000	10000	10000	10000	10000	10000	10000	10000

5. GENERAL RULES FOR FLOW METER APPLICATION

When using an ultrasonic flow meter in a piping containing a particular fluid, certain conditions need to be met to ensure correct measurements. The limiting operational parameters of the fluid (i.e. temperature, pressure and flow velocity) as well as the mechanical design and properties of the meter sensor (flow stabilisation piping sections before and after sensor, complete flooding of the sensor cavity at all times, elimination of cavitation effects and fluid foaming) must comply with the requirement for steady fluid flow with no gas bubbles or foam appearing in the piping. Such conditions are different for various types of fluid and need to be correctly identified for each specific measuring spot and/or technological piping system.

CAUTION: Ultrasonic flow meter of a specific DN must not be used in piping of lesser sizes (smaller DN).

Selection of measuring spots in piping systems must be done in observance of certain basic rules. Incorrect placement of meter may result in deteriorated measurement stability or precision. To the extent possible, avoid meter placement after valves or pumps in piping. The recommended minimum lengths of straight piping sections before and after the meter are 5DN and 3DN, respectively (see Fig. 13).

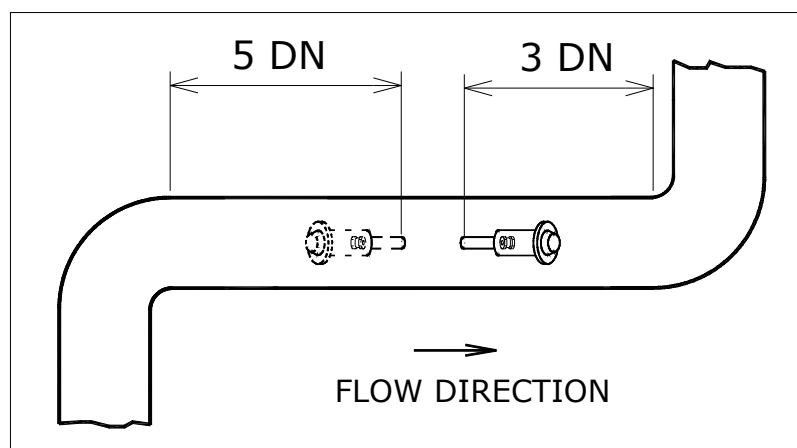

Fig. 13 Recommended fluid stabilisation piping section before and after the ultrasonic flow meter

If there is a pump in the piping, the recommended length of straight piping section between the pump and sensor is 20DN. If there is at the sensor input side a fully open valve, the recommended length of straight piping section is 10DN. If it is a valve with fluid control function, the straight piping section should be at least 40DN long (see Fig. 14).

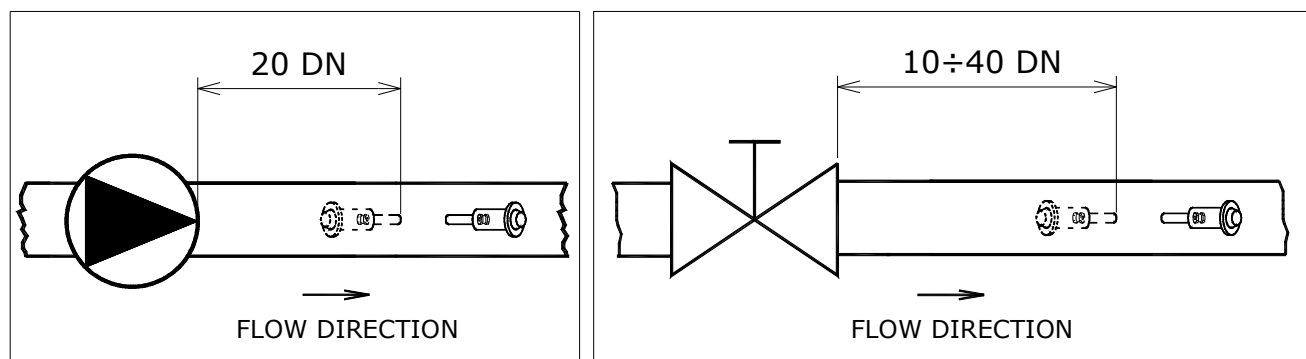

Fig. 14 Straight piping sections to eliminate the effect of disturbances on the sensor input side

In the cases of a disturbance after the sensor, the required minimum length of straight piping section is 3DN (see Fig. 15).

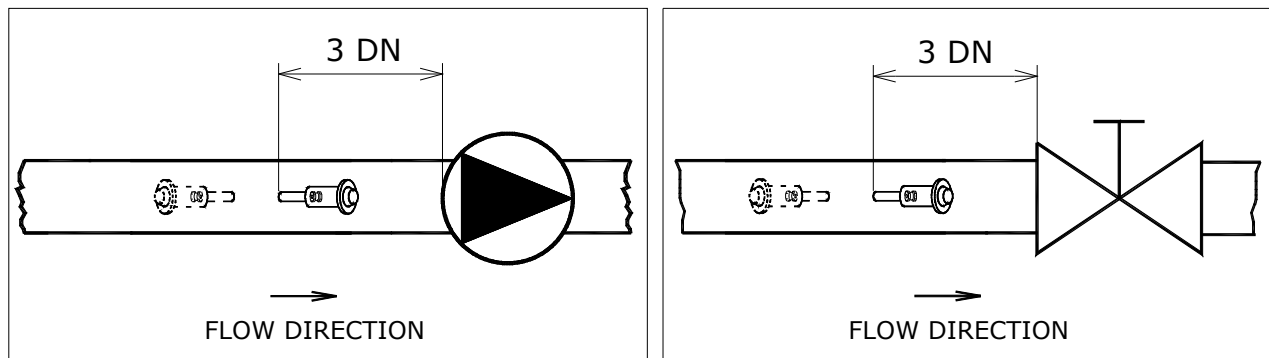

Fig. 15 Straight piping sections to eliminate the effect of disturbances on the sensor output side

If complete flooding of the whole piping system cannot be guaranteed at all times, the flow sensor should be located at bottom pockets in the piping where this requirement is met under all circumstances and operational conditions (see Fig. 16).

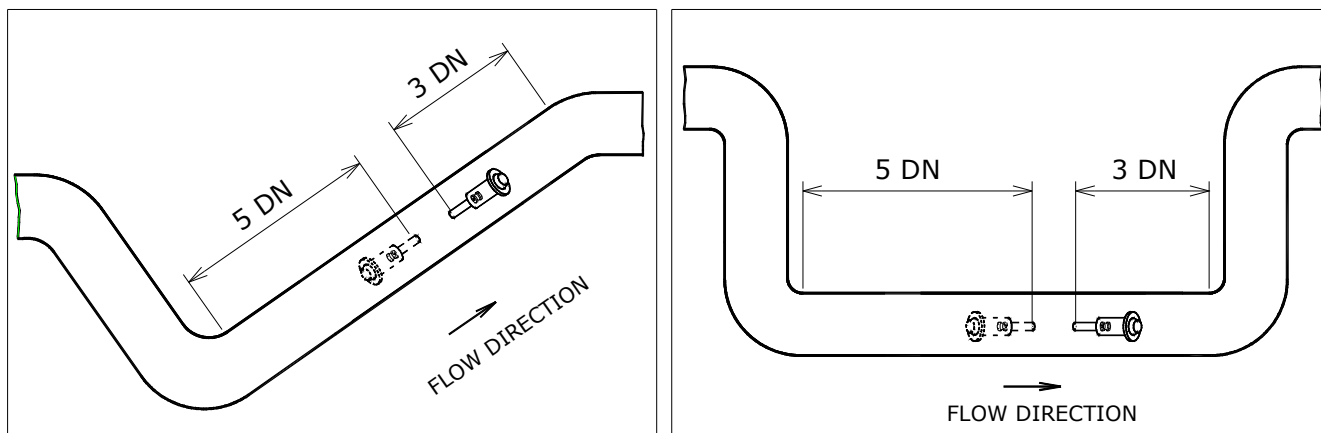

Fig. 16 Sensor placement in bottom pockets ensuring complete flooding at all times

Where the meter sensor is to be placed in a vertical piping section, the flow direction shall be upwards (see Fig. 17).

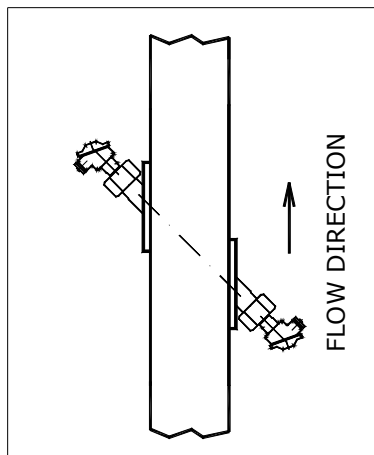

Fig. 17 Sensor fitted into a vertical piping section

To ensure correct measurement at all times, make sure that the sensor flow profile is always completely filled with the measured fluid. Avoid sensor placement at top pockets or in vertical piping sections with the flow direction downwards, in particular in the cases of piping sections discharging fluid to open tanks (see Fig. 18).

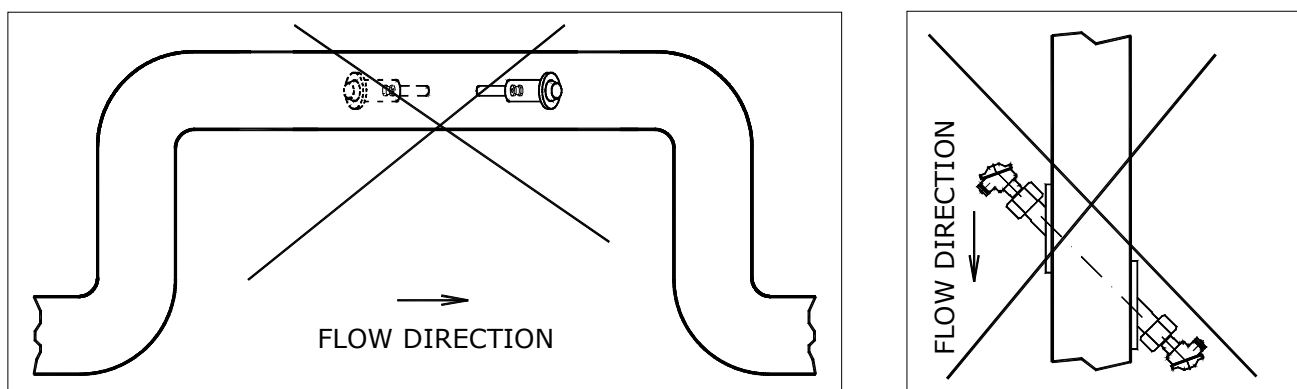

Fig. 18 Examples of incorrect sensor placement

6. FLOW METER INSTALLATION

6.1. Meter assembly and installation principles

The flow meter assembly and installation must be done in strict observance of the rules and recommendations in this product manual.

To minimise electromagnetic interference, make sure that the signal cables are laid at least 25cm away from the power cables feeding other electrical equipment. Shielded conductors are recommended to use for all signal lines. Any extension connections between signal conductors must be soldered and the soldered joints protected by suitable installation boxes against climatic and mechanical stresses. All cables must be led outside the thermal insulation layers on piping (if applicable). Proper earthing is required for the electronic unit. To do that, use earthing conductor of cross section 4mm^2 or larger and connect the earthing bolt on the electronic unit box with the meter piping at the measuring location (see Fig. 19).

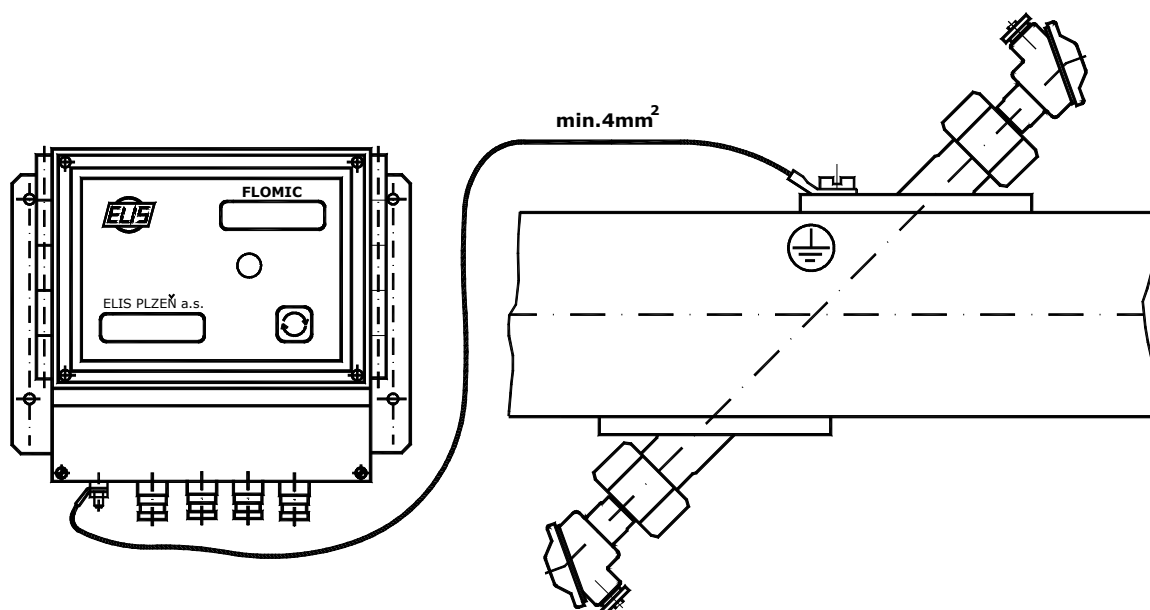



Fig. 19

 ELIS PLZEŇ a. s.	Product application, installation and service manual	Page 14 of 40
	FLOMIC FL 3005 – battery-powered ultrasonic flow meter for direct installation in piping	

6.1.1. Recommended assembly fixtures and tooling

Apart from special measurement and assembly fixtures listed in Section 3.2 above, you will need the following:

Emery cloth No 60

Water level, min. length 400mm

Flexible steel ruler, length 1,000mm

Steel measuring rule, length 3m

Steel measuring tape, flat, min. length 10m

Slide rule

Marking awl

Hammer

Centre punch

Steel angle 40 x 40mm, length 0.6D_o

Sheet of paper, dimensions 1.1D_o x 1.8D_o

Drawing tools (setsquare, drawing pen etc.)

White chalk

Black spirit marker, ø 1mm

Rubber rope bandages

Thread cap for welded-on piece, G 1"

Half-round file

Steel pin ø 7mm, length 200mm

Side spanner, size 19mm, 2 pieces

Calculator with trigonometric and other mathematical functions Electric welding equipment, 250A including accessories

Oxy-acetylene equipment and cutting torches

Hand-held angle grinder, grinding wheel ø 125mm

Hand-held electric drill, max. chucking diameter 12mm

6.1.2. Flow meter installation criteria

6.1.2.1. Measuring spot selection

When selecting the piping section where the flow-meter sensor is to be installed (see also Chapter 5), make sure that the surface quality of the piping, in particular any irregularities of shape, deformations, the position and surface finish of welding joints, whether longitudinal, helical or others, is such that it allows for accurate determination of the angle formed by the measuring ray and the longitudinal axis of the piping.

6.1.2.2. Necessary room for flow sensor installation

The flow sensor installation in the existing piping (using the fixtures and tooling specified in this manual) requires free room of at least 900mm to the sides of the welded-on pieces and in the direction of the measuring ray (see Fig. 20).

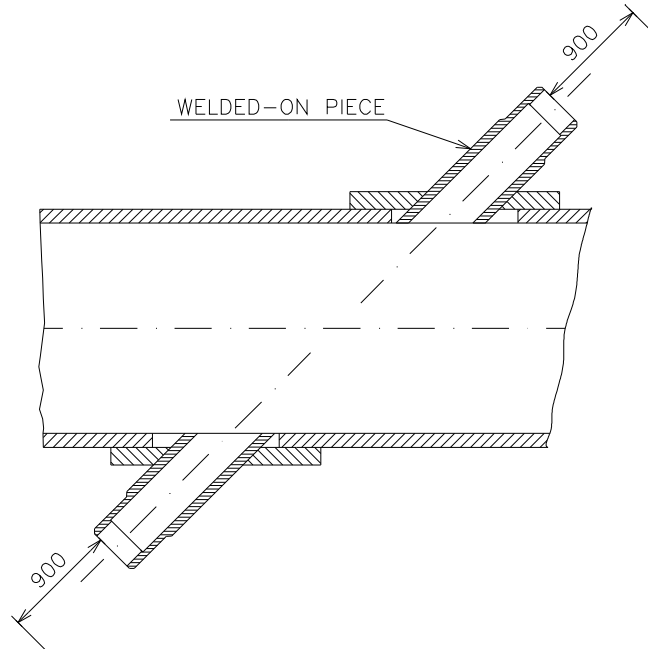

Fig. 20 Required free room in the vicinity of welded-on pieces

In the ideal case, the ultrasonic ray axis should lie in the horizontal plane. Should the spatial limitations necessitate selection of another angle of the ultrasonic ray, the method of marking the key installation points on the piping needs be modified accordingly. The manufacturer's specifications require that the angle formed by the ultrasonic ray and the horizontal plane should not exceed 30°.

The preparatory steps for the sensor installation, determination of the mechanical parameters of the measuring spot and the installation process itself as described below have been designed for application at the customer's plant and operating conditions.

6.1.3. Preparatory and measuring operations on meter piping

The surface of the meter piping must be clean and smooth; any adhering dirt, rough irregularities of shape, corrosion products and traces of paint must be removed.

6.1.3.1. Determination of OD of meter piping

Each of the two methods described below can be used:

Diameter calculation from piping circumference

This method is suitable for piping of larger sizes. Measure the piping circumference using a flat steel measuring tape.

The outer diameter of the meter piping can then be calculated as follows: $D_o = \frac{O}{\pi}$

where O is piping circumference, being the average value of two circumference measurements taken at the locations where the welded-on pieces are to be attached.

Direct diameter measurement using diameter gauge Take three diameter measurements, equally spaced (120° apart) along the piping circumference, at each of the two intended positions of the welded-on pieces. Calculate the outer piping diameter as the average value of the average diameter values measured at the positions of the welded-on pieces:

$$D_{o1} = \frac{D1 + D2 + D3}{3} \qquad D_{o2} = \frac{D4 + D5 + D6}{3}$$

$$D_o = \frac{D_{o1} + D_{o2}}{2}$$

Where D1 to D6 are the measured OD values on the meter piping.

6.1.3.2. Marking of top surface line

Use water level to identify the top surface line on the meter piping (see Fig. 20). The two points of the surface top line (a_1 , a_2) are the points of contact between the piping and water level after the water level has been set in the horizontal position. The distance between points a_1 and a_2 is recommended to be selected equal to the piping diameter ($b = D_o$). Use a steel ruler to draw the top surface line p_v .

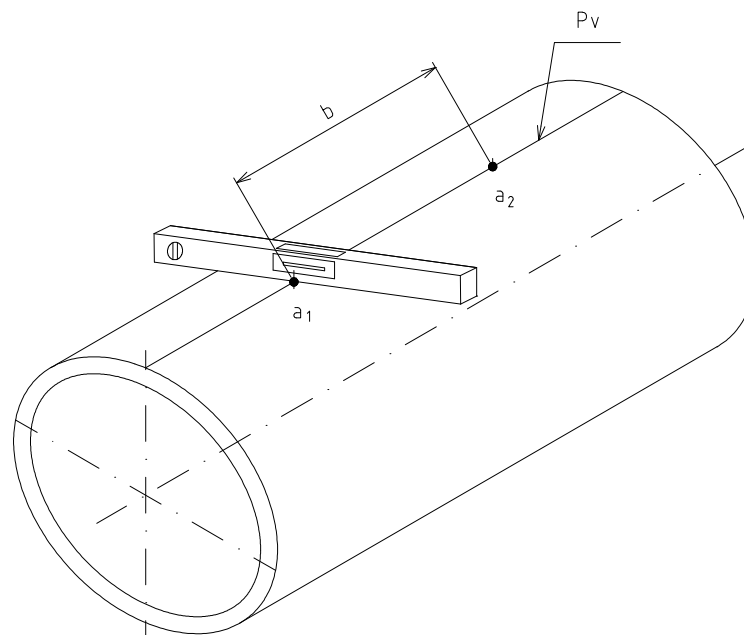

Fig. 20 Top surface line marking on meter piping.

6.1.3.3. Laying out of installation points

To identify and mark the key sensor installation points on the meter piping, select and use one of the following two methods. The indirect method is less time-consuming and therefore preferred in most practical situations.

Direct method – Measurements are taken and installation points marked directly on the meter piping

Indirect method – The installation points are transferred onto the piping by means of a template drawn on a sheet of paper.

Direct method:

Draw two parallel surface lines p_{b1} and p_{b2} at the distance of $\frac{\pi \cdot D_o}{4}$, i.e. $D_o \times 0.7854$ left and right of the top surface line (see Fig. 21).

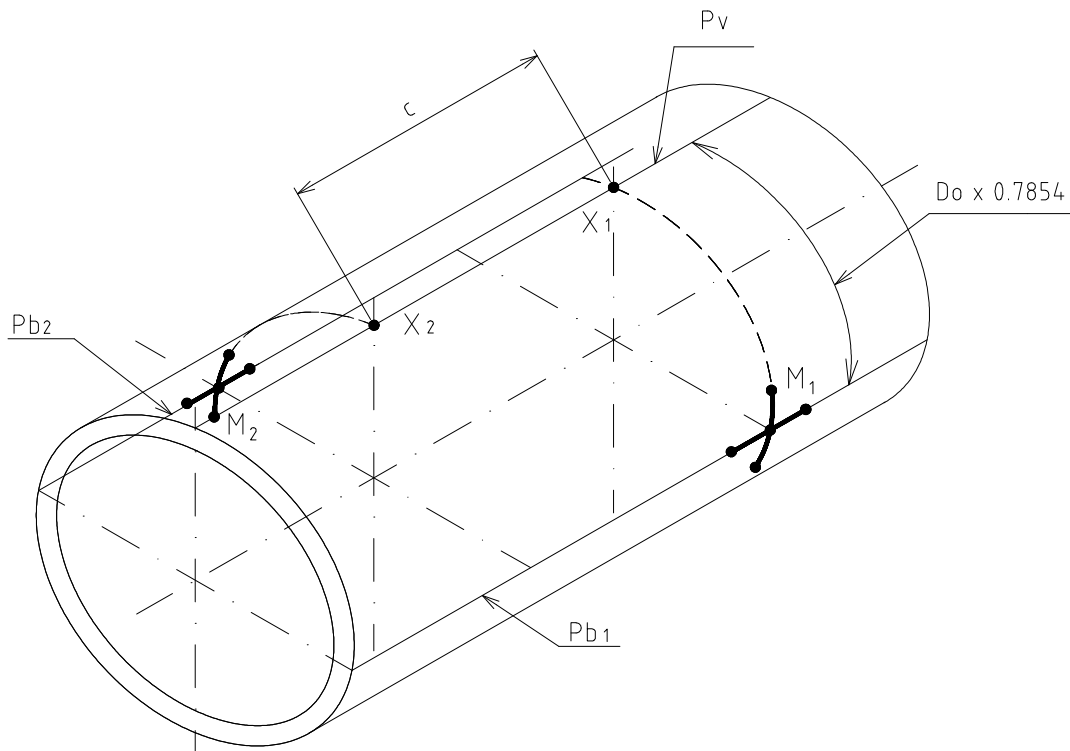

Fig. 21 Laying out of key installation points

On the top surface line p_v mark two points (X_1 and X_2) at the distance of c . Distance c is defined by the formula

$$c = \frac{D_o}{\text{tg } \alpha}, \text{ from which it follows:}$$

$$\text{for } \alpha = 45^\circ \quad c = D_o; \text{ and}$$

$$\text{for } \alpha = 60^\circ \quad c = D_o \times 0.5774.$$

From points X_1 and X_2 on the top surface line lead perpendicular lines along the piping surface towards the parallel lines p_{b1} and p_{b2} . The intersection points (M_1 and M_2) are the points where the ultrasonic ray is to penetrate the surface of the meter piping. The points M_1 and M_2 serve the purpose of accurate setting of the mounting positions of the welding flanges. Identify the positions of points M_1 and M_2 by crosses of lines of at least 100mm each and mark the cross line ends by centre punch dots (see Fig. 21).

Indirect method:

Prepare a template of installation points using a sheet of paper of minimum dimensions $1.1 \cdot D_o \times 1.8 \cdot D_o$.

- A.** Draw a centre line (p_v) and mark on it points X_1 and X_2 at the distance of $\frac{D_o}{\text{tg}\alpha}$ (for $\alpha = 45^\circ$ it is D_o , for $\alpha = 60^\circ$ the distance of $D_o \times 0.5774$).
- B.** At points X_1 and X_2 draw parallel lines perpendicular to central line p_v , one on each side, and mark on them points M_1 and M_2 at the distance of $D_o \times 0.7854$. Identify points M_1 and M_2 by crosses of lines of minimum length 100mm (see Fig. 22).

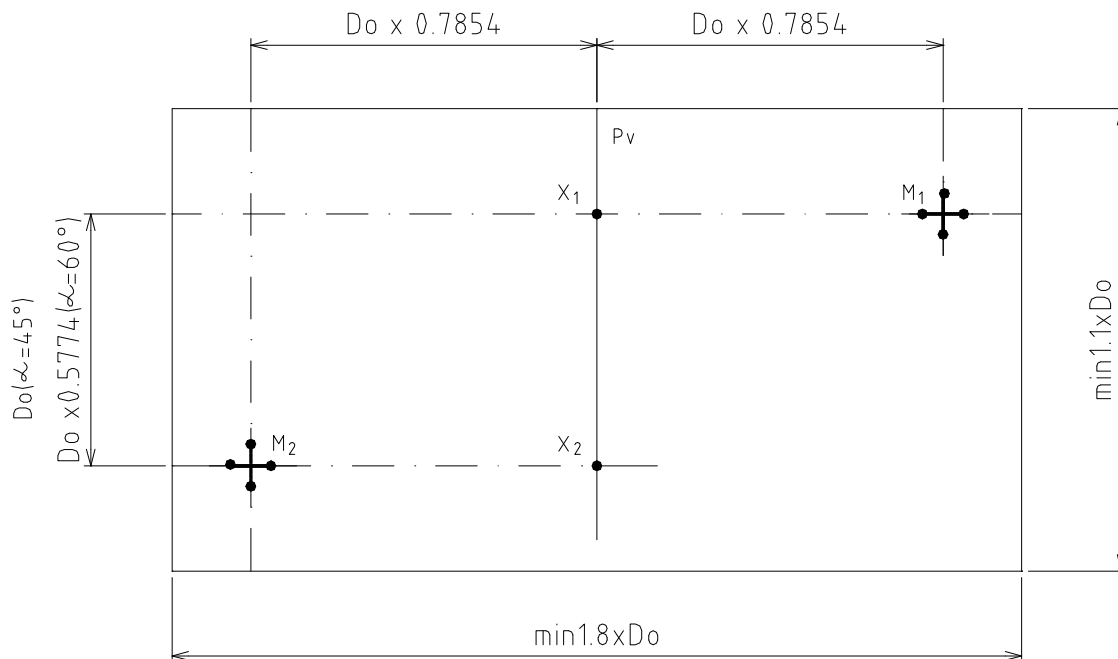

Fig. 22 Paper template

- C.** Lay the paper template on the piping so that the central line p_v coincides with the top surface line marked on the meter piping. Then, using a centre punch, transfer all key installation points including the ends of the cross lines onto the piping.
- D.** Using a drawing awl, mark the crosses defining points M_1 and M_2 on the piping surface as with the direct method above.

6.1.4. Fitting welded-on pieces into meter piping

- A.** Using oxy-acetylene torch, cut circular holes in the meter piping of diameter 60mm and centres at points M_1 and M_2 . Prevent the cut-out section from falling inside the piping and save them; they will be needed to determine the inner diameter of the meter piping. In the cases of pipe with the wall thickness t in excess of 5mm (for $\alpha = 45^\circ$), or t greater than 15mm (for $\alpha = 60^\circ$), the holes of diameter 60mm need be modified so that the welded-on pieces can be inserted into the piping as shown in Fig. 23. Make sure that both the inner and our edges of the holes are smooth and clean.
- B.** Ground the edges of the cut-out sections without damaging the surface parts. Then use a slide rule to determine the thickness of the pipe wall.

- C. Slide the welding flanges onto the welded-on pieces and adjust their positions with respect to the setting marks. The insertion depth shall be such that the bottom part of the welded-on piece is flush with the internal surface of the meter piping (see Fig. 23). Mark on the welded-on piece the correct depth of insertion of the same into the flange.

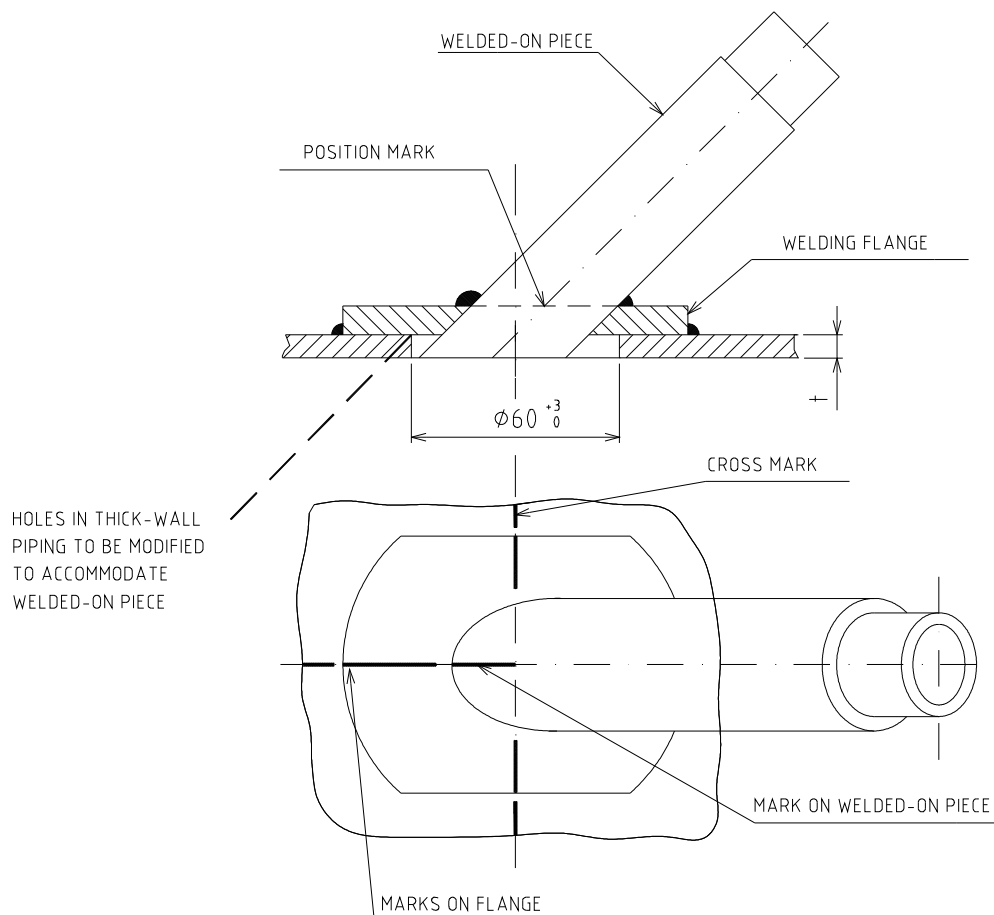

Fig. 23 Assembly of welded-on pieces

- D. Assemble the rectification pin of the following component parts:
 milling adaptor I,
 connecting parts selected to fit the piping size, and
 protractor adaptor.

The parts must be properly tightened to form a stable whole.

The rectification pin assembly parts and their fitting are shown in the following picture.

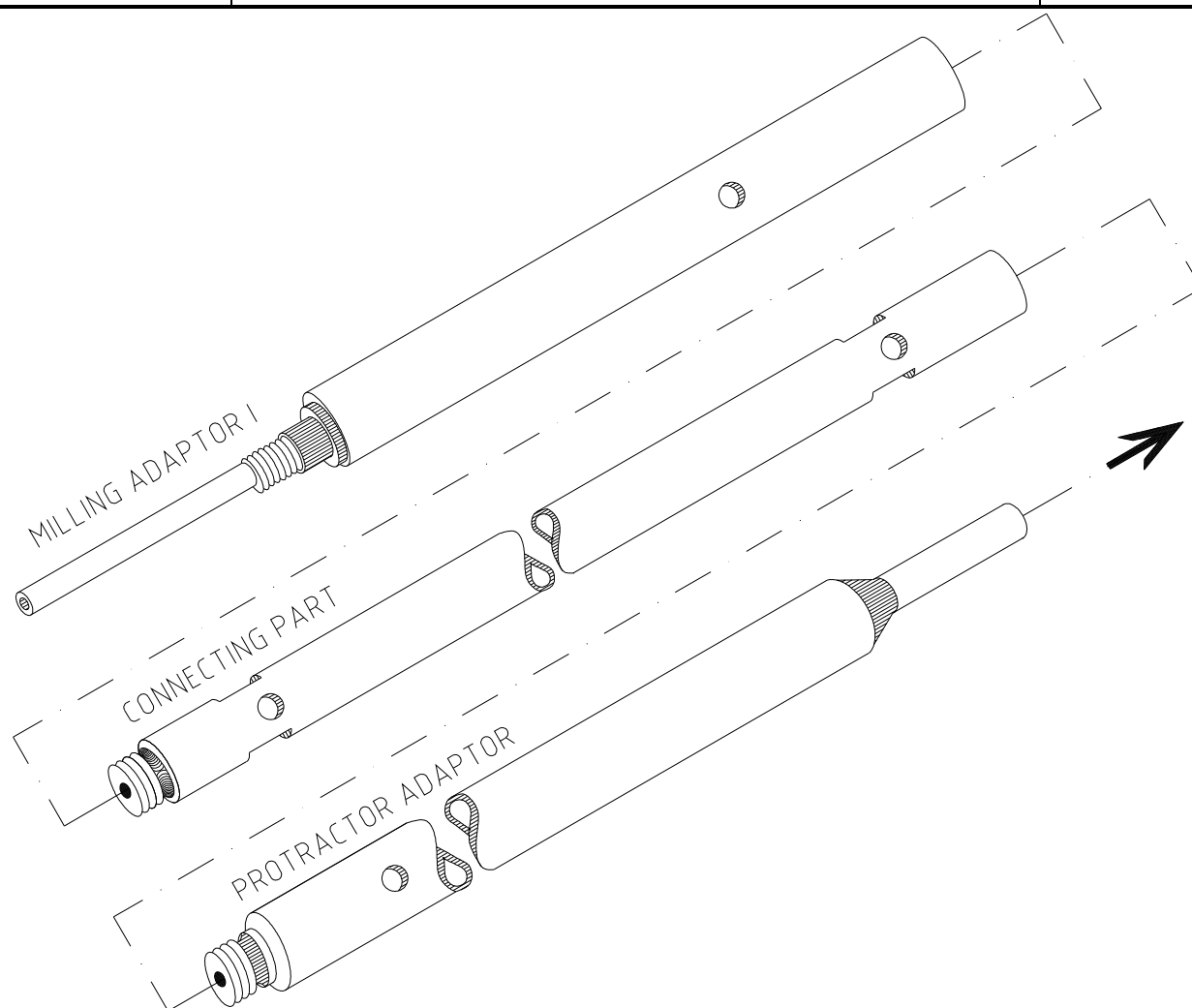

Fig. 24 Rectification pin assembly parts

Insert the assembled rectification pin into the holes in the meter piping in the direction indicated by the arrow in Fig. 24.

- E.** From both sides of the meter piping, slide the welding flanges and welded-on pieces on the rectification pin. The flange marks must be positioned against the cross marks drawn on the meter piping. The welded-on pieces shall be set to the desired position with respect to the assembly marks. Check the ease of movement of the rectification pin in the welded-on pieces.
- F.** Check the correct setting of one of the flanges with respect to the respective cross mark and fix its position by four point welds. Repeat the procedure with the other flange.
- G.** Check the play of the rectification pin in the welded-on pieces (it shall be easily rotated and moved in the axial direction). Apply fillet welds to fix the positions of the flanges on the piping.
- H.** Using the assembly marks, set the correct positions of the welded-on pieces in the flanges and fix them by several point welds.
- I.** Check the play of the rectification pin in the welded-on pieces again. Apply fillet welds to secure positions of the welded-on pieces in the respective flanges.

Comment:

When performing the welding operations with the welded-on pieces slid on the rectification pin, make sure that the functional parts of the welded-on pieces cannot be damaged by the flying sparks and protect them by suitable covers or nuts. Should it be found that, at any time during the welding operations, the rectification pin has lost its desired play (free rotation and displacement in the holes in the welded-on pieces), the reason for that condition must be established and the defect removed by slight knocking on the welded-on pieces (with the thread protected).

It is recommended to check the rectification pin play after each welding operation.

6.1.5. Facing of seating surfaces on welded-on pieces

To ensure a perfect alignment of the ultrasonic probes, the seating surfaces on the welded-on pieces need be end-faced. To do that, fit a milling tool onto the milling adaptor I (fitted onto the rectification pin) and secure its position by a nut (see Fig. 25).

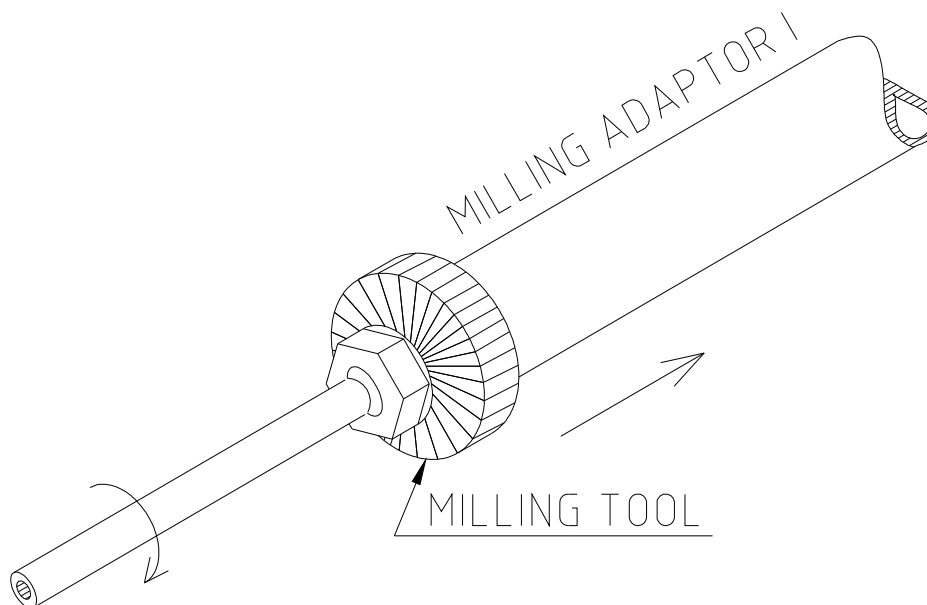

Fig. 25 Facing of the seating surfaces on the welded-on pieces

Grease slightly (with vaseline) those parts of the rectification pin that will rotate in the welded-on pieces. Using a hand-held drilling machine with controlled speed, rotate the rectification pin in the clockwise direction and face the seating surface on the welded-on piece. Then remove the rectification pin assembly, insert it into the welded-on pieces in the opposite direction and face-mill the other seating surface.

Should there be insufficient room on the other side of the piping, do not remove the rectification pin but replace the protractor adaptor by milling adaptor II with a milling tool attached, secure the threads against turning (using Loctite or similar bonding agent) and face the (otherwise inaccessible) seating surface by pulling the rectification pin out and rotating it in the counter-clockwise direction (see Fig. 26).

After the milling operation, remove the milling tool and nut and leave the rectification pin inserted in the welded-on pieces on the meter piping.

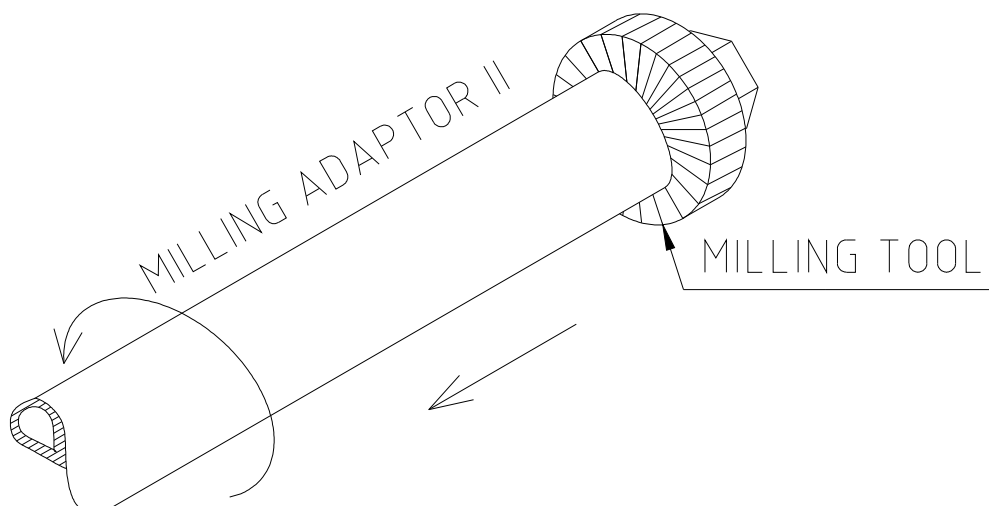

Fig. 26 Facing of the seating surface on the inaccessible welded-on piece

6.1.6. Determination of mechanical parameters of the meter sensor

To achieve the specified measurement precision of the FLOMIC FL 3005 flow meter, the mechanical parameters (dimensions) of the meter piping need be determined with the tolerances of $\pm 1 \text{ ‰}$.

Example: For DN 500 meter piping with the measurement ray angle $\alpha = 45^\circ$ and the distance between the outer-end faces of the welded-on pieces $L = 850\text{mm}$, the mechanical parameters need be determined with the dimensional errors not exceeding:

$$\Delta L = \frac{L}{1,000} = 0.85\text{mm}$$

$$\Delta D_1 = \frac{D_1}{1,000} = 0.5\text{mm}$$

Angle α needs be determined with the precision of $\Delta\alpha = 0.1^\circ$ irrespective of the meter piping size (DN).

6.1.6.1. Measuring ray angle

- A. Remove all corrosion products, traces of paint and other contamination from the piping surface where the strap piece is to be laid.
- B. Place the strap piece on the piping so that its longitudinal axis is parallel to the side surface line on the piping. Use rubber bandages to hold the strap piece firmly in position on the piping surface (see Fig. 27).
- C. Attach a protractor onto the protractor adaptor mounted at one of the rectification pin ends.
- D. The angle α measurements (three measurements at each of the welded-on piece positions) shall be performed in the plane defined by the longitudinal piping axis and the respective side surface line. Between the measurements knock slightly on the strap piece or move it to the side and back to ensure its correct seating.
- E. The value of α shall then be determined as the arithmetic average of all measurements taken:

$$\alpha = \frac{\alpha_1 + \alpha_2 + \alpha_3 + \alpha_4 + \alpha_5 + \alpha_6}{6}$$

where α_1 to α_3 are measured angles formed by the rectification pin and the surface of the meter piping at one of the welded-on pieces, and α_4 to α_6 are angles formed by the rectification pin and the surface of the meter piping at the other welded-on piece.

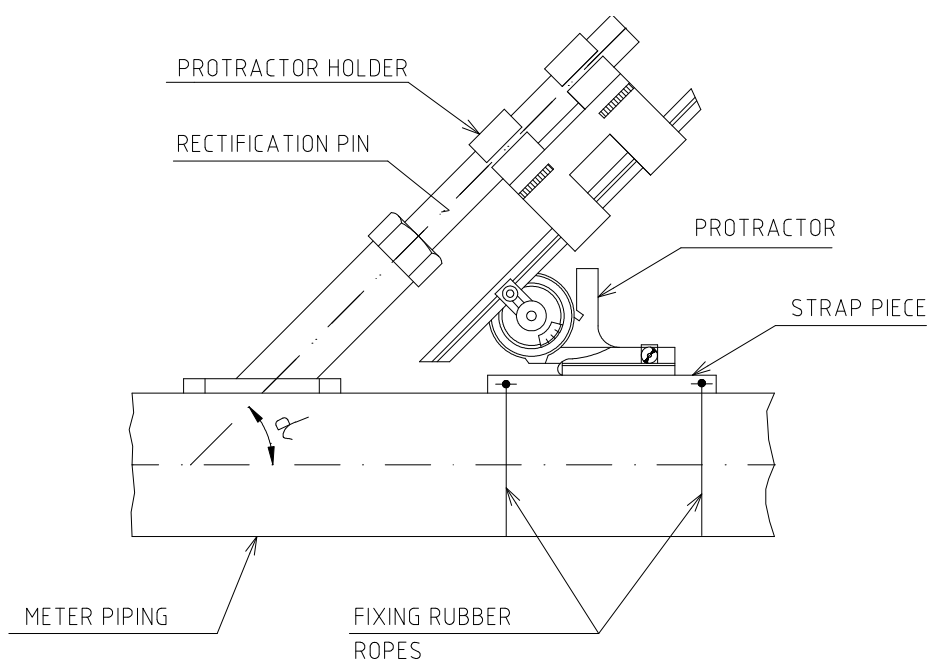

Fig. 27 Determination of the measuring ray angle

6.1.6.2. Distance between the outer-end faces of welded-on pieces

Depending on the given arrangement and space available (the inner diameter of the meter piping, free room in the vicinity of the welded-on pieces etc.), the distance L between the outer-end faces of the welded-on pieces can be determined either by direct measurement using a suitable gauge or steel rule inserted by means of an auxiliary pin into the welded-on pieces, or indirectly, by making marks on the rectification pin and measuring the distance between them after removal of the pin from the welded-on pieces (see Fig. 28).

The auxiliary pin used to insert a steel rule into the meter piping should be of a smaller diameter than the rectification pin. Such pin is not included in the delivery kit.

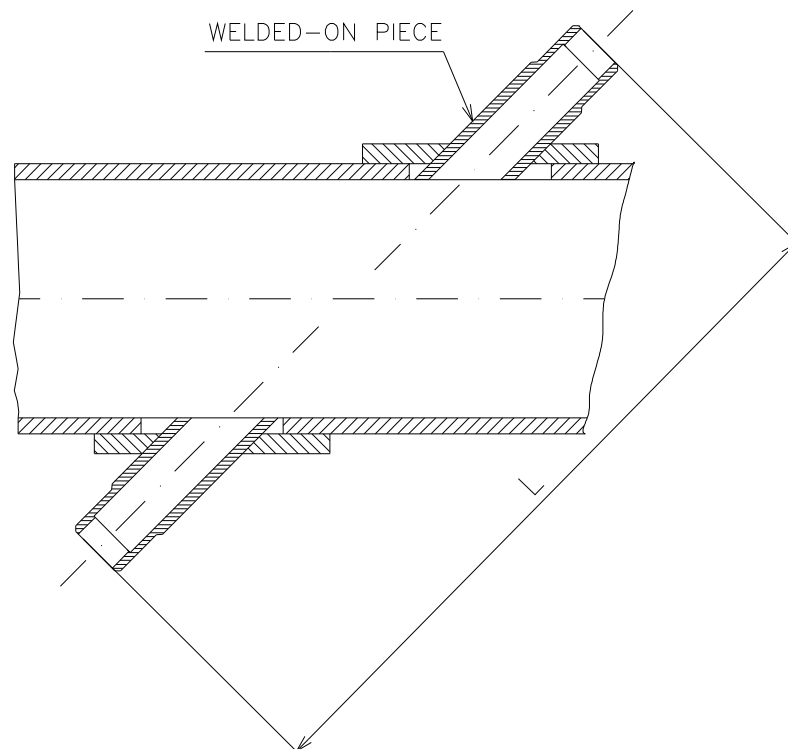

Fig. 28 Determination of distance L

6.1.6.3. Inner diameter of meter piping

The meter piping is integral part of the piping system where flow measurements are to be performed. The ID of meter piping can be determined by calculation as follows:

$$D_i = D_o - 2 t$$

where t is the pipe wall thickness.

The OD of the meter piping (D_o) was determined earlier using the procedure outlined in Section 6.1.3.1 above.

The pipe wall thickness t should be determined by measurement on the cut-out sections acquired when holes were cut in the pipe wall for fitting of the welded-on pieces. Each section shall be measured three times at spots 120° apart and the value t calculated as the average of the six measurements taken. Regarding conditioning of the cut-out sections prior to measurement see Section 6.1.4 - B.

6.1.7. Flow meter sensor assembly

The preceding assembly and measurement operations have yielded the following basic sensor parameters necessary to perform the so-called theoretical meter calibration:

- measuring ray angle α
- distance L between the outer-end faces of the welded-on pieces;
- inner piping diameter D_i

Upon finishing the measurements, the sensor assembly can be completed. Insert the ultrasonic probes including sealing into the welded-on pieces and tighten the holding nuts using the torque of 150 Nm.

Connect coaxial cables from the probes to terminal strip X1 of the associated electronic control unit (see Fig. 29). The meter is now ready for theoretical calibration.

6.1.8 External signal connections

Remove the lid held in position by two M4 screws at the bottom of the front panel of the UP 8.00 electronic unit box to gain access to the terminal strip for sensor probe cables and output signals.

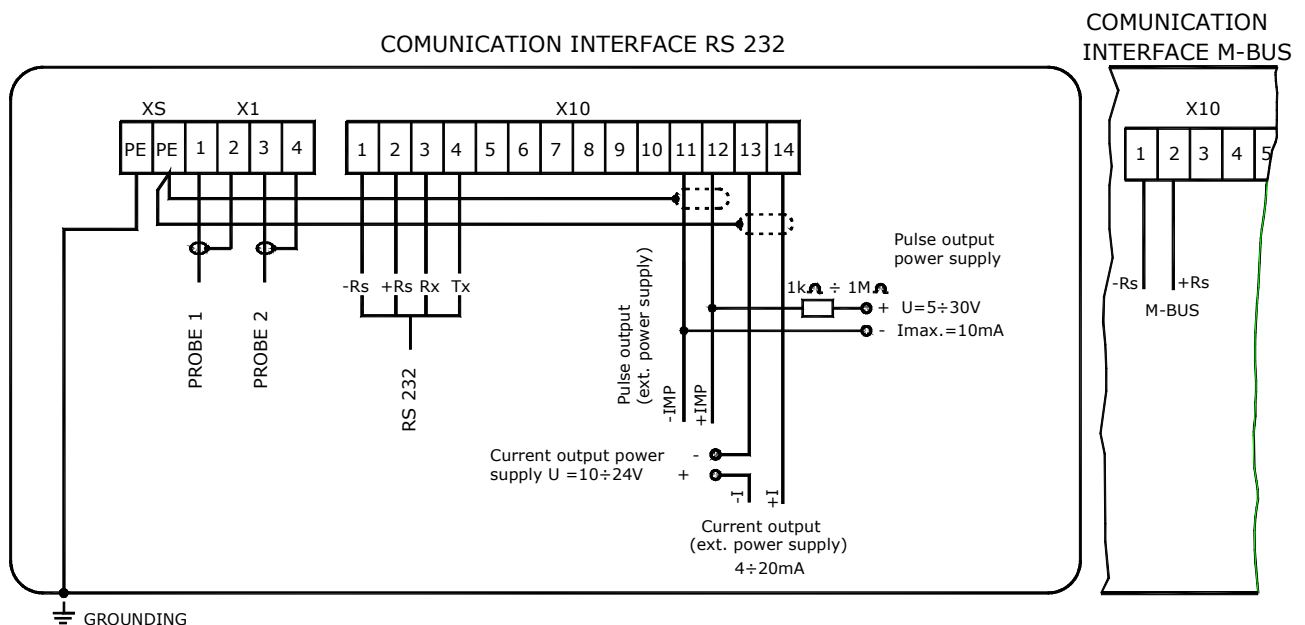

Fig. 29 Input and output signal connections of the UP 8.00 electronic unit

To ensure correct functioning of the flow meter, ultrasonic probes 1 and 2 must be connected as shown in Fig. 30 (probe 1 must be closer to the output end of the sensor and probe 2 on the input side). The probe cables are marked accordingly.

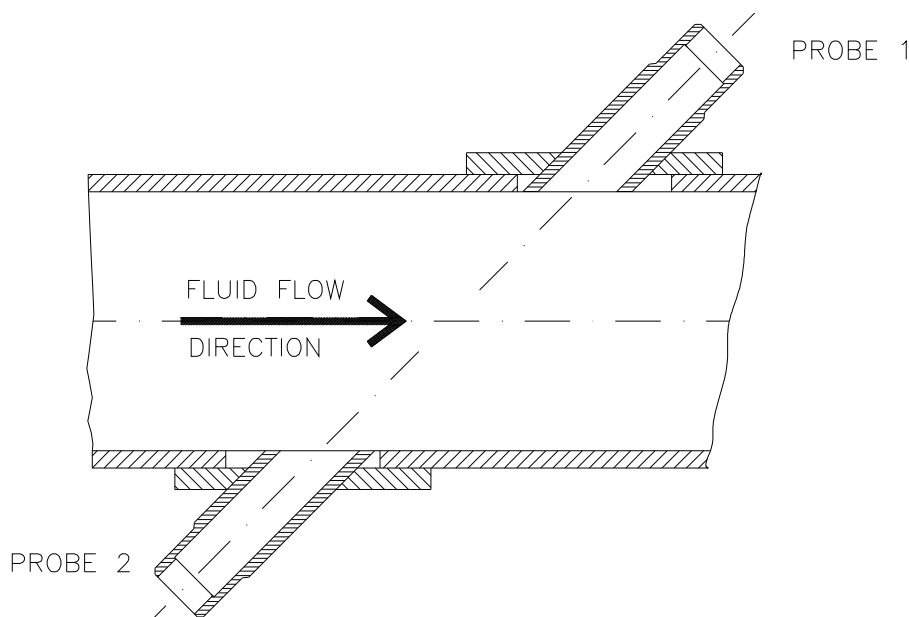

Fig. 30 Probe marking

7. SETTING FLOW METER IN OPERATION

7.1. Theoretical calibration

The relationship between flow rate q and flow velocity v is given by the general formula $q = f(v)$.

Function f depends on the meter piping ID, the inner surface roughness, viscosity of the measured fluid and, to some extent, the delay of the probe excitation signal in the coaxial cable connecting the probe and the electronic control unit.

In practical situations, the theoretical meter calibration is done using the TheoCalc and CaliberFL programs generating the $q = f(v)$ function for all flow rate values.

7.2. Description of calibration procedure

The necessary equipment and data:

PC and calibration programs **TheoCalc 1.0** and **CaliberFL 2.3**

Communication cable or optical reading probe

Meter piping data: maximum flow rate

Inner diameter

distance between the face parts of the welded-on pieces

probe length

angle formed by probes and longitudinal piping axis

length of the probe cables

multiplier (10 or 100 – shown on the front panel under the display unit)

The theoretical calibration consists of three steps:

7.2.1. TheoCalc program

Start the TheoCalc program and fill out the table in Fig. 31. At this stage, the PC need not be connected to the meter control unit.

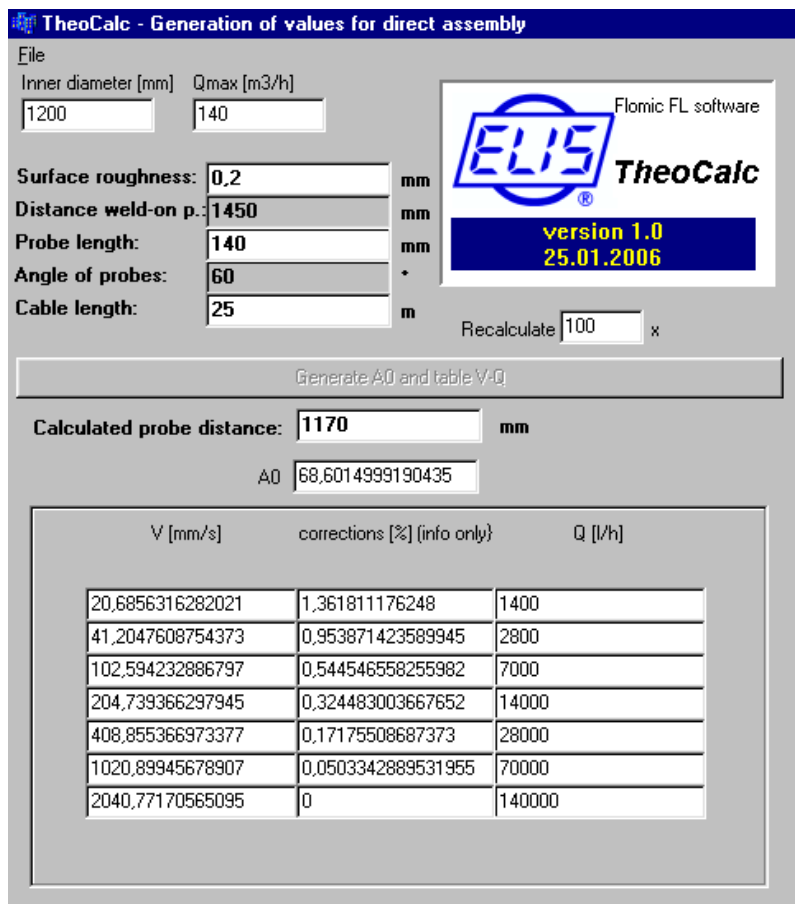

TheoCalc - Generation of values for direct assembly

File

Inner diameter [mm] Qmax [m³/h]

Surface roughness: mm

Distance weld-on p.: mm

Probe length: mm

Angle of probes: °

Cable length: m

Recalculate x

Generate A0 and table V-Q

Calculated probe distance: mm

A0

V [mm/s]	corrections [%] (info only)	Q [l/h]
20,6856316282021	1,361811176248	1400
41,2047608754373	0,953871423589945	2800
102,594232886797	0,544546558255982	7000
204,739366297945	0,324483003667652	14000
408,855366973377	0,17175508687373	28000
1020,89945678907	0,0503342889531955	70000
2040,77170565095	0	140000

Fig. 31

Table data entry instruction: enter data into blue fields; double-click the mouse to move between fields. The following data need be entered:

- Inner diameter – inner diameter of the meter piping
- Qmax – maximum flow rate
- Surface roughness – inner piping surface roughness; recommended value 0.2
- Distance weld-on p. – distance between face parts of welded-on pieces
- Probe length
- Angle of probes – angle formed by probes and longitudinal piping axis
- Cable length – length of coaxial cables connecting probes and el. unit
- Recalculate – multiplier (shown on the electronic unit rating plate)

Upon entering all required data depress key “**Generate A0 and table V-Q**” to perform calculations and fill out the bottom table. Then click on “**File**”, “**Write**” and store the data file. The file name should consist of the first five digits of the production series number (without slash and the production year) and the “btp” suffix.

7.2.2. CaliberFL program

Using coaxial cable or optical probe, connect your PC to the electronic control unit and start the CaliberFL program. With the table shown in Fig. 32 displayed, check the agreement between the port number displayed in the table and the number of the port to which communication channel is connected. Should it be necessary to change the port number, stop and re-initialise the CaliberFL program.

Please note that:

- unless communication is in operative condition, the menu items are not accessible;
- to rewrite data in a particular field, double-click on such field
- if Qmax is changed, the program must be reset
- do not let the program run without the communication channel connected/operative
- should communication appear not to work properly, close and re-initialise the program.

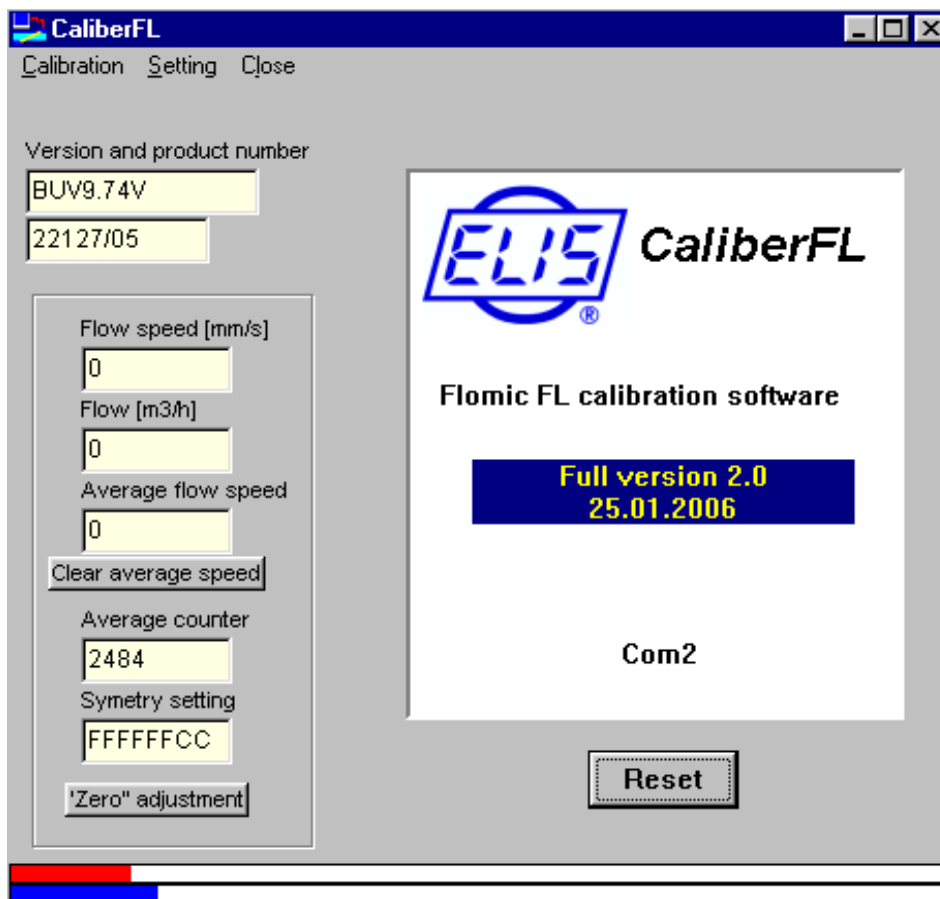
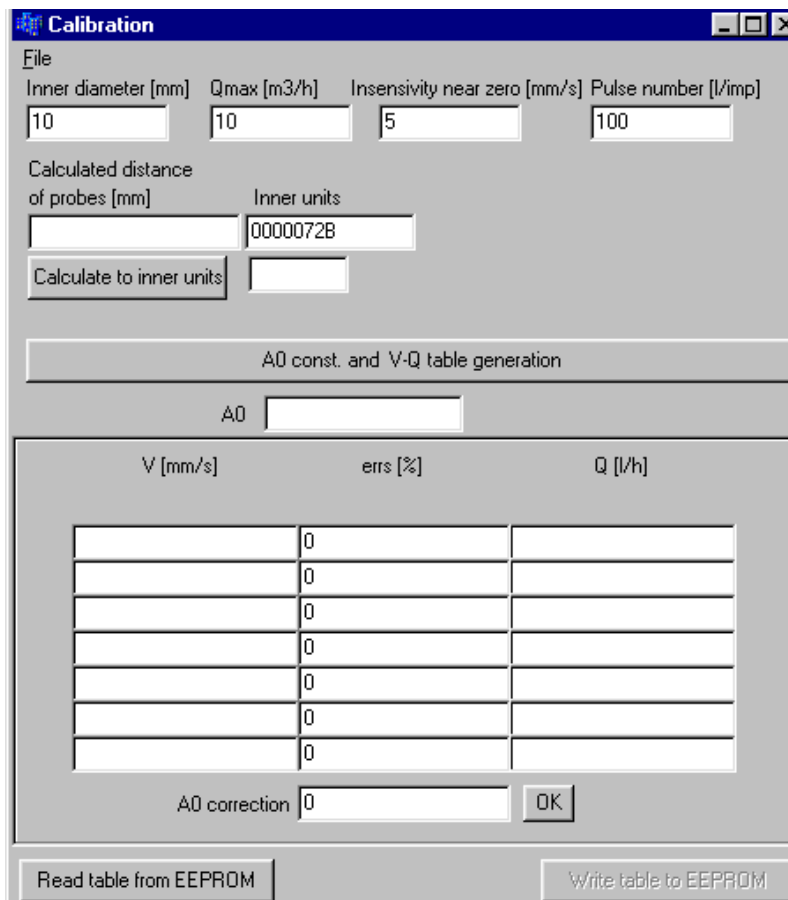

Fig. 32

Click on “**Calibration**” to have the following empty table displayed (see Fig. 33).



Calibration

File

Inner diameter [mm] Qmax [m3/h] Insensitivity near zero [mm/s] Pulse number [l/imp]
 10 10 5 100

Calculated distance of probes [mm] Inner units
 _____ 0000072B

Calculate to inner units _____

A0 const. and V-Q table generation

A0 _____

V [mm/s]	errs [%]	Q [l/h]
	0	
	0	
	0	
	0	
	0	
	0	
	0	

A0 correction 0

Fig. 33

Using the following procedure, copy into this table the data created by the TheoCalc program. Click on “**File**” and “**Open**” to access the screen in Fig. 34. Select the file created by TheoCalc and click on “**Open**” to transfer it to the previous table shown in Fig. 33.

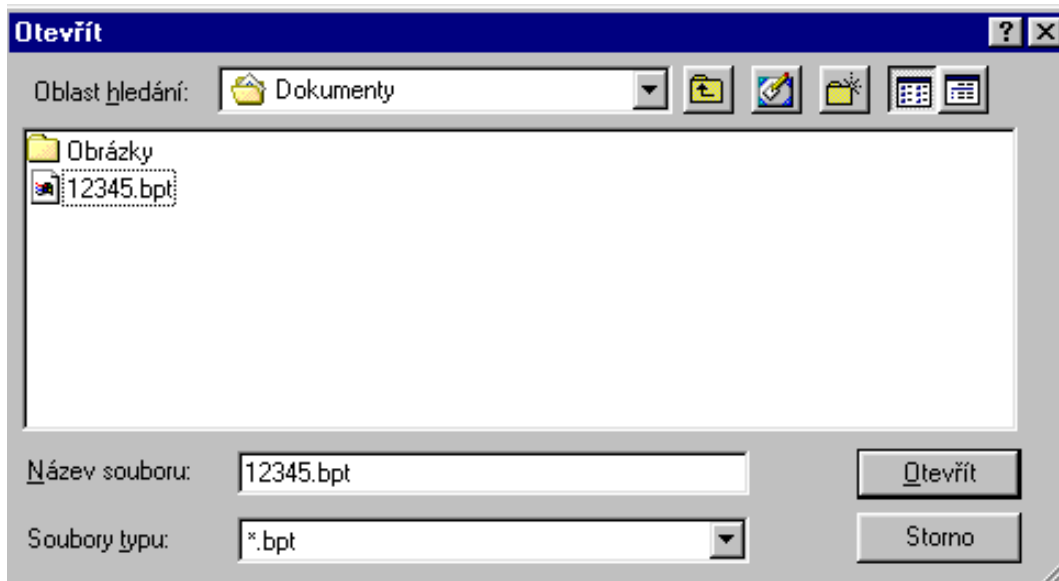

Otevřít

Oblast hledání:

Obrázky

12345.bpt

Název souboru:

Soubory typu:

Fig. 34

In the filled-out table (see Fig. 35) select and double-click on the field “**Insensitivity near zero**” and enter the required insensitivity (typically 20; values less than 10 are not recommended). Then fill out the field “**Pulse number**”, taking into account the given multiplier (for example: for desired impulse number 10,000 l/min and multiplier 100 enter 100). The maximum Pulse number permitted is 110. Then click on software key “**Calculate to inner units**” whereby the key “**Write table to EEPROM**” will be enabled. Use this key to start the programming procedure. When this is completed, close the table.

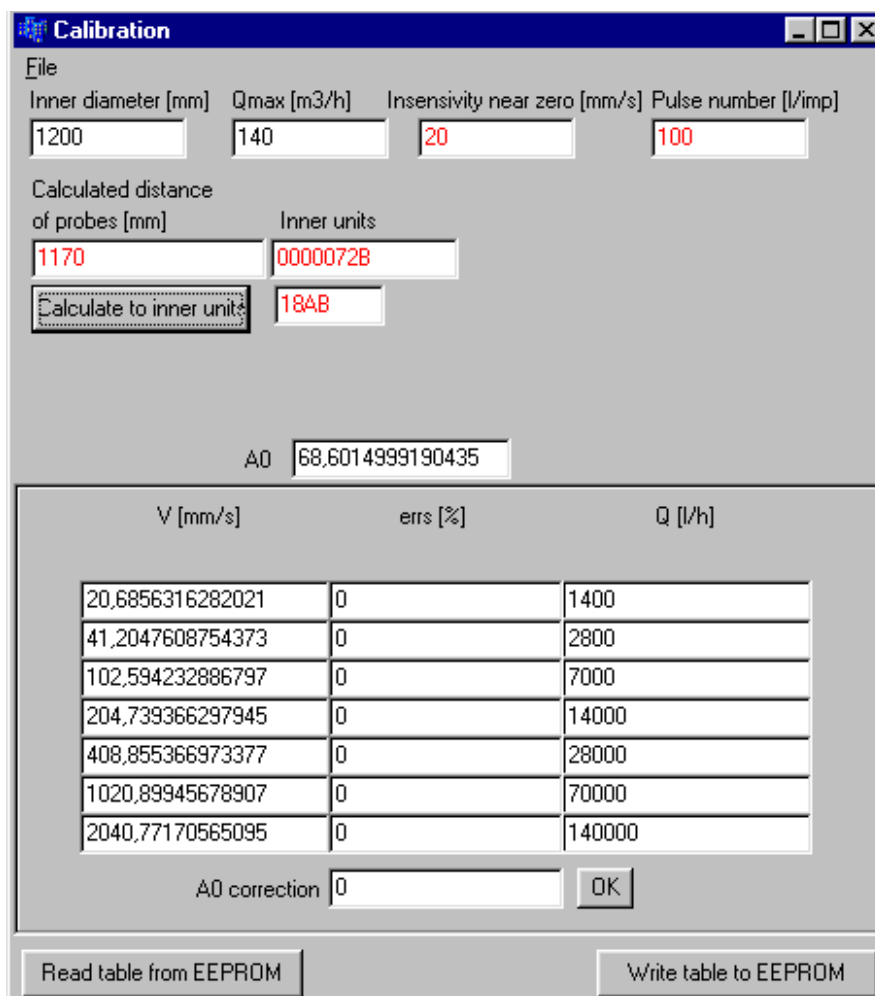

Calibration

File

Inner diameter [mm] Qmax [m³/h] Insensitivity near zero [mm/s] Pulse number [l/imp]

1200 140 20 100

Calculated distance of probes [mm] Inner units

1170 0000072B

Calculate to inner units 18AB

A0 68,6014999190435

V [mm/s]	errs [%]	Q [l/h]
20,6856316282021	0	1400
41,2047608754373	0	2800
102,594232886797	0	7000
204,739366297945	0	14000
408,855366973377	0	28000
1020,89945678907	0	70000
2040,77170565095	0	140000

A0 correction 0 OK

Read table from EEPROM Write table to EEPROM

Fig. 35

Now, provided the meter piping is fully flooded, the flow meter will start operation – the **E1** field signalling error on the display will go dark and, provided the fluid in the piping is flowing, the meter will display the actual flow rate.

7.2.3. Check on zero setting

If you can arrange for zero flow rate (by closing the valves before and after the meter or by switching off the fluid pump), check the flow-rate zero setting. Run the **CaliberFL** program again and display the table in Fig. 36.

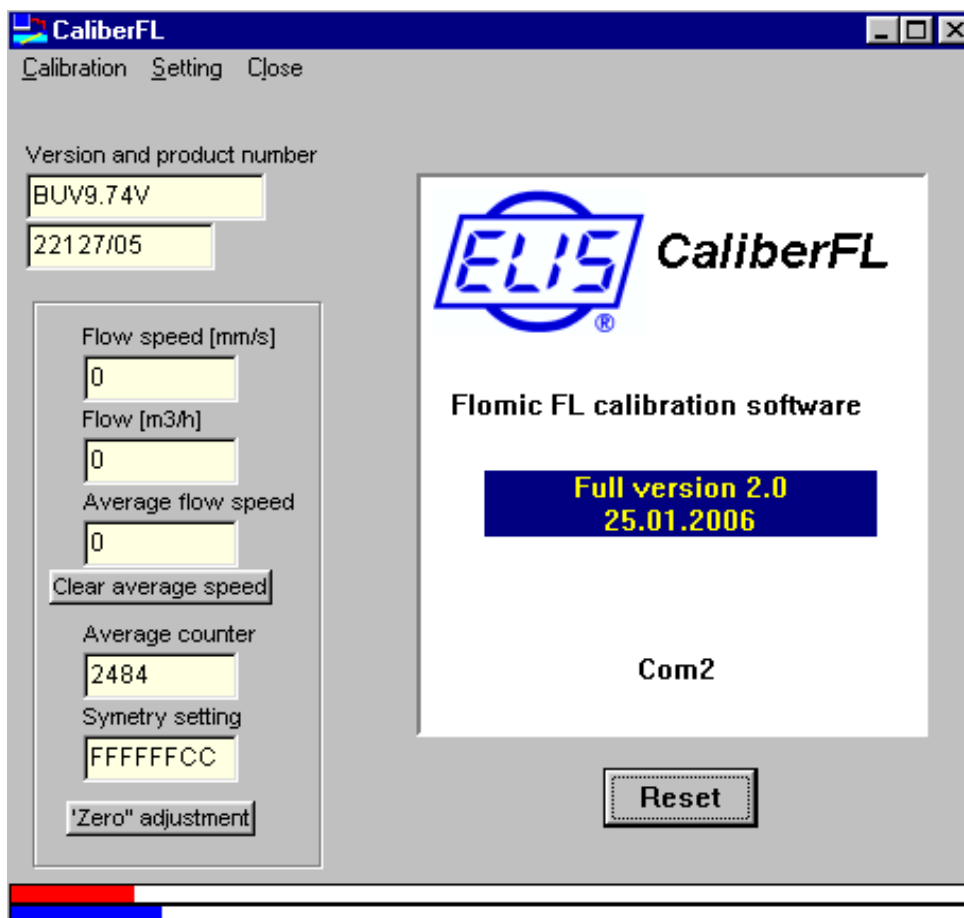

Fig. 36

Click on the key “**Clear average speed**” and reset the readings “**Average flow speed**” and “**Average counter**” (the corresponding number of the measurements taken). The reading “**Flow speed**” should be within the limits of -10 mm/s and +10 mm/s; should any of these limit values be exceeded, check the tightness of closed valves. When the reading at “**Average counter**” reaches about 120, click on the key “**Zero adjustment**” to modify the reading at “**Symmetry setting**”. About six seconds later, repeat the procedure of the zero setting check. Now the reading at “**Average flow speed**” should not be greater than ± 2 mm. The phenomenon called “**rocking**” can be observed with long piping where the steady state after the valve closure may take several minutes to attain. In such a case wait till the reading at “**Flow speed**” drops below 4 mm/s and then perform the zero setting check. **If the condition of zero flow rate cannot be ensured, the zero setting procedure is not performed.**

8. METER OPERATION

8.1. Reading measured data from display

The 8-character display unit shows the values of flow rate in m³/hour or the total fluid volume in m³ passed through the meter sensor. The figures on display must be multiplied by appropriate coefficients (see the table below). The displayed value of instantaneous flow rate has certain time delay; it is calculated as the average value of the last six measurements taken over the last six seconds. Such floating average values are displayed and brought to the meter outputs. The delay due to the average value calculation may become noticeable in the cases of rapid flow-rate increase and decrease. Should an error in the meter function be detected, the corresponding error message is displayed. Because of the power-saving mode of the battery supply, the push-button switching

commands changing the display modes from flow-rate to total fluid volume and back can be given no faster than once a second. It is therefore recommended that, to ensure correct switching function, the control push-button be held depressed for at least one second and the period between two successive switching commands be longer than one second. The position of the decimal point on the display (see Fig. 37) depends on the measured total fluid volume and the applicable multipliers (see the table below).

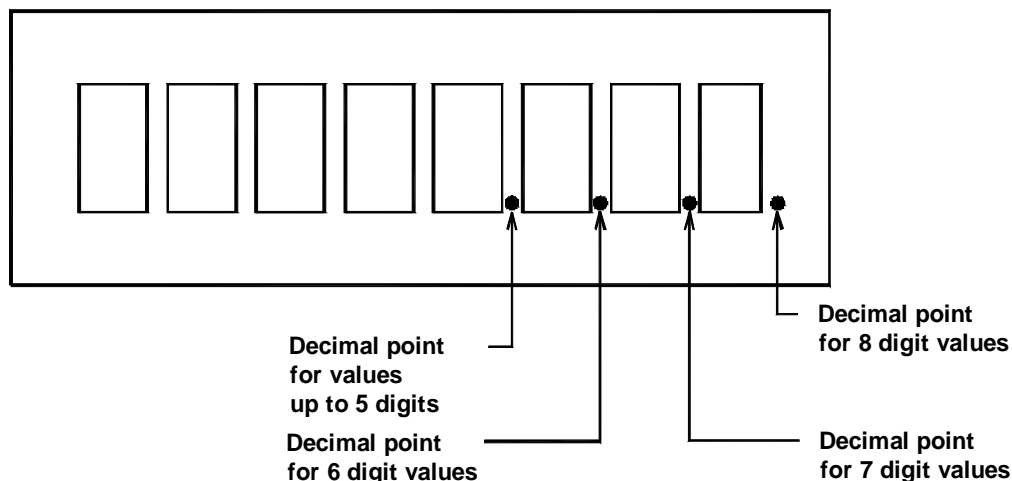

Fig. 37 Decimal point positions on the display

CAUTION: The display readings and values read from the archive files must be multiplied by one of the coefficients shown in Table 4 below. The applicable coefficient is given on the front panel under the respective units of measurement (m^3 , m^3/h ; see the dimensional drawing in Section 3.3.2 above).

Piping size (DN)		200 to 450	500 to 2,000
Coefficient	m^3/h	x 10	x 100
	m^3		

8.2. Electrical outputs

8.2.1. Impulse output

The passive impulse output is a standard feature of all meter versions. It is an optically isolated output connected to terminals 11 and 12 of the output terminal strip X10 (see Fig. 29, Section 6.1.8) with maximum loading capacity of 10 mA. The impulse width preset at the manufacturing plant is 2 ms. It can be reset at any time to 40 ms using jumper J5 (see Fig. 38).

Impulse output setting by means of jumper J5:

Jumper J5	1 – 2	2 – 3
Impulse width	2 ms	40 ms
Impulse level	L (0 V)	L (0 V)
External voltage	3 to 30 V	5 to 30 V
Loading current range	0.003 to 10 mA	0.1 to 10 mA
Loading resistor	1 k Ω to 1 M Ω	1 k Ω to 50 k Ω

The minimum loading resistance depends on the external voltage used:

$$R_{\min} [\Omega] = \frac{U[V]}{0.01[A]}$$

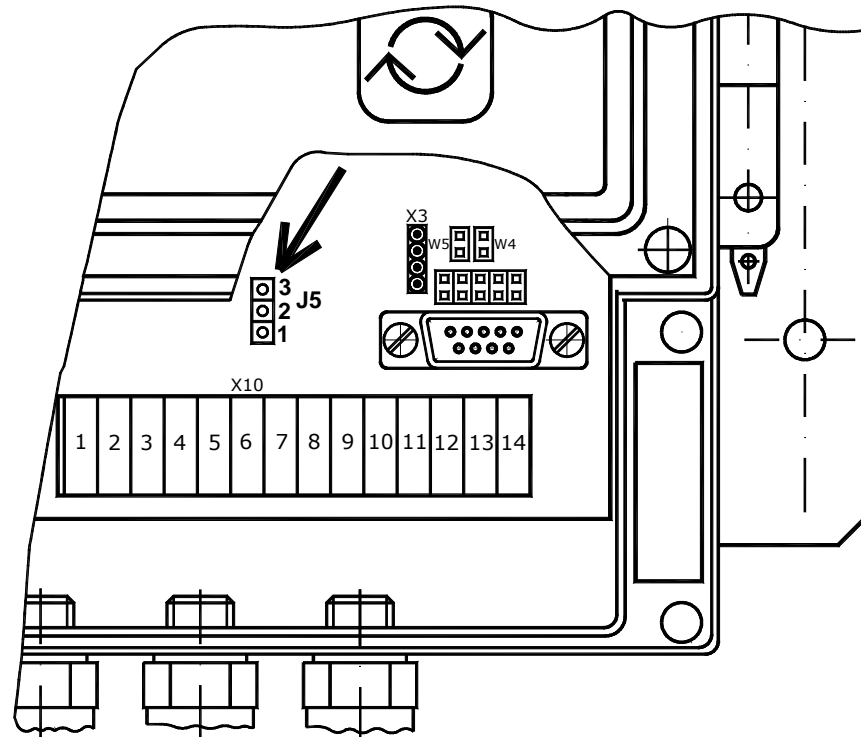

Fig. 38 Position of jumper J5

8.2.2. Current output

The passive current output 4 to 20 mA is connected to terminals 13 and 14 of the output terminal strip X10 (see Fig. 29, Section 6.1.8). Upon reaching the upper limit of the output current (20 mA corresponding to Q_{max}), the output current will grow no longer and error message E4 will appear on the display (see Section 8.5). To use the current output, connect an external DC power source of 10 to 24V to the output terminal board as shown in the schematic diagram in Section 6.1.8. The maximum permitted current-loop resistance (ohmic resistance of the line + input resistance of the customer-specific signal-processing device) is given by the following formula:

$$R_s [\Omega] = \frac{U_{source} [V] - 7}{0.02}$$

8.3. Communication interface

8.3.1. Optical interface

The optical interface facilitates reading of the real-time data (instantaneous flow rate and total fluid volume), the stored data, setting of the data-archiving parameters and reading of error messages. The meter software makes possible storage of data on instantaneous flow rate, the total fluid volume measured in specified time intervals, and the maximum and minimum values of instantaneous flow rate over a specified period including the times when such extreme values occurred. Recorded also are any error messages including the times of occurrence. To use this facility, the user must have available the ArchTerm PC program and an optical probe including a connecting cable 1.5m long provided with the RS 232 connector. On request, the optical probe can be supplied with the USB connector.

The optical probe shall be applied to the respective reading window below the LC display on the front panel of the electronic control unit. The correct probe position is defined by two positioning pins. The probe is then held in place on the front panel by means of a permanent magnet.

CAUTION: For the correct data transmission, turn the probe so that cable grommet is on the bottom side (see Fig. 39).

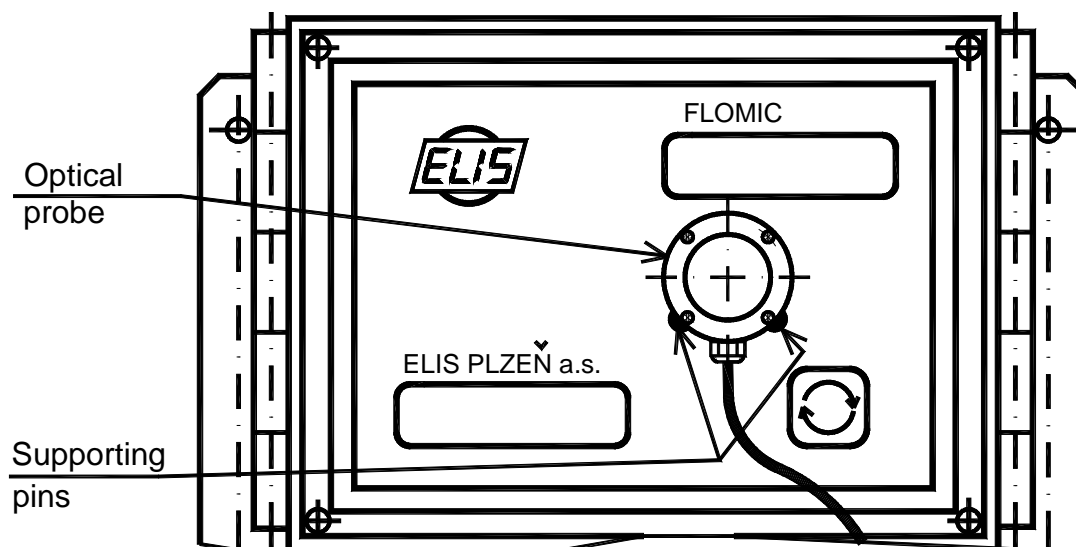

Obr.39 Working position of the optical probe

8.3.2. RS 232 interface

The cable of the RS 232 communication line is connected to terminals 1 through to 4 on the terminal strip X10 of the meter control unit (see Fig. 29). The RS 232 line makes possible data reading and storage, reading of error messages and setting of the data archiving parameters in the same extent as described in Section 8.3.1. To use this communication facility, the personal computer connected to the meter control unit must have the ArchTerm program installed. The RS 232 interface is also compatible with a GSM module. The meter system configuration including the RS 232 interface as supplied from the manufacturing factory cannot be customer-modified to M-bus communication.

8.3.3. M-Bus interface

The M-bus communication interface is connected to terminals 1 and 2 on the terminal strip X10 of the meter control unit (see Fig. 29). The fixed communication cable facilitates reading of the measured data on instantaneous flow rate and total fluid volume passed through the meter sensor. The M-bus interface configuration cannot be changed at the customer's plant to the RS 232 format.

8.4. Communication modes

8.4.1. Optical probe + personal (notebook) computer

The optical probe cable is provided with a connector – either RS 232 or USB, depending on the customer requirements (see Fig. 40). In the case of the USB interface, a special controller needs to be installed into the computer.

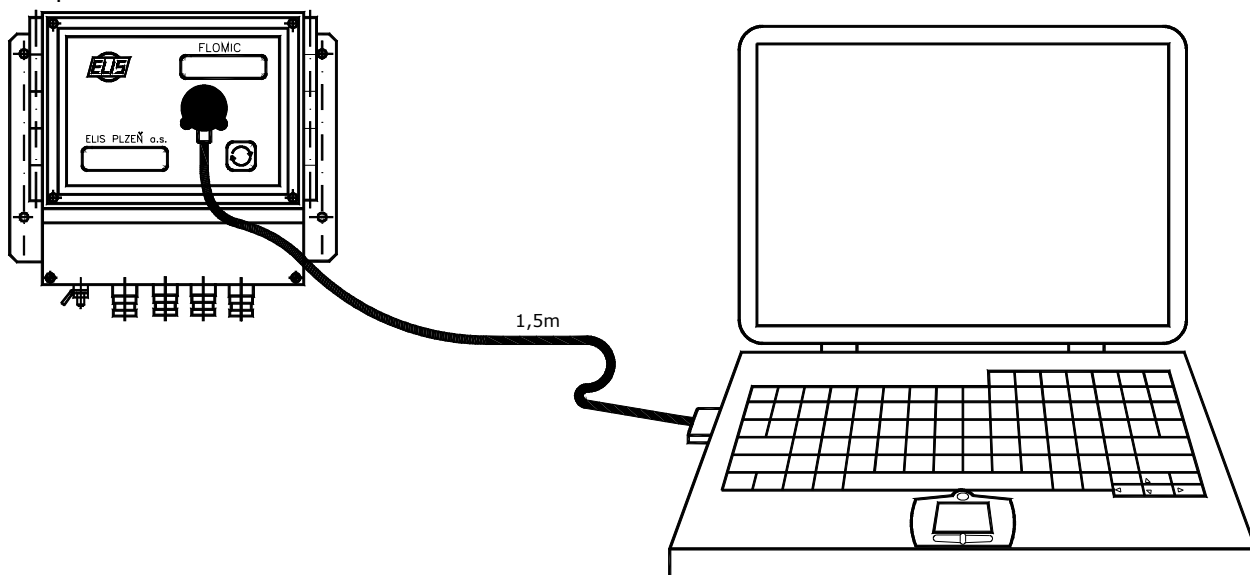

Fig. 40 Communication via optical probe

8.4.2. RS 232 + personal (notebook) computer

At one end of the connection box sealed with a plastic compound is a fixed 5m-long cable to be connected to terminals 1, 2, 3 and 4 on terminal strip X10 of the meter control unit. This cable can be cut shorter as need be. The other end of the connection box is provided with a connector to accommodate another cable to connect the co-operating personal computer. On the computer side, this cable is terminated with an RS 232 connector (see Fig. 41).

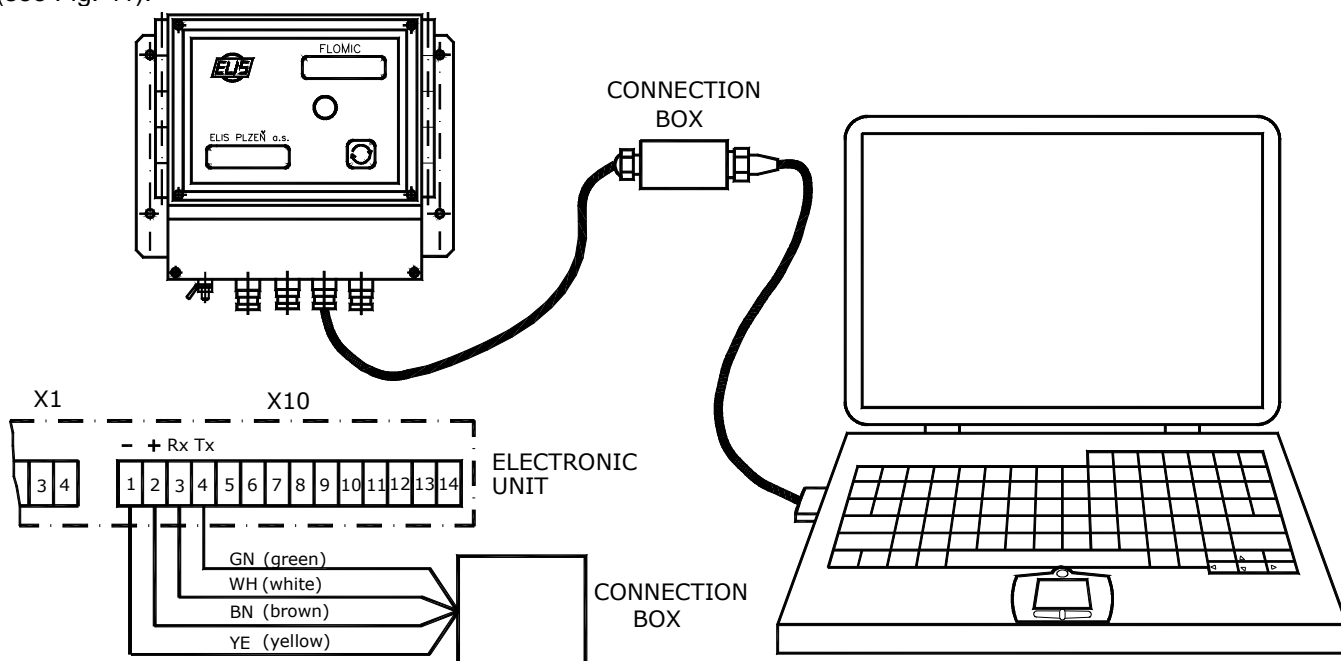

Fig. 41 Communication via RS 232 interface

8.4.2. RS 232 + GSM module

The meter control unit can be connected to a GSM module by means of an RS 232 communication line (see Fig. 42). One end of the connecting cable is provided with a connector matching its counterpart on the GSM module, the other end should be connected to terminals 1, 2, 3 and 4 of the X10 terminal strip on the meter control unit. The cable is supplied 5 metres long and can be shortened as need be.

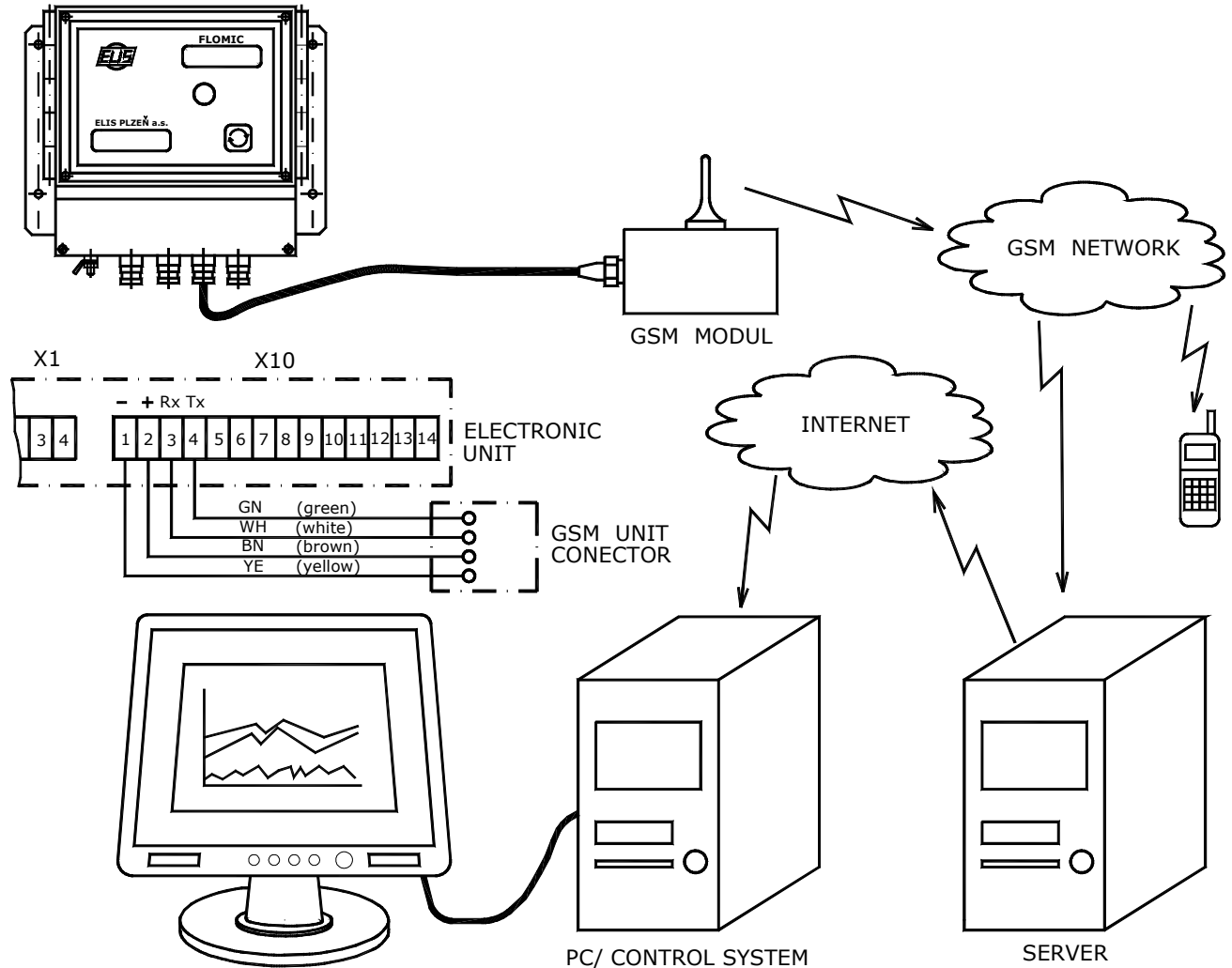

Fig. 42 Flow-meter data communication via a GSM port

8.5. Error identification

Meter errors E1 through to E5 are indicated by symbol ▼ at the bottom of the meter display unit.

- Types of error indicated:
- E1 - The passage of ultrasonic waves in the sensor is blocked, e.g. by air bubbles or mechanical particles
 - E2 - Too great difference between the transit times of ultrasonic waves travelling in and against the fluid flow direction; e.g. due to an air bubble caught at one of the probes, which may be a transient condition during filling the piping with fluid, or due to excessive contamination of the face part of a probe
 - E3 - A/D converter error, e.g. due to strong electromagnetic interference
 - E4 - Flow rate greater than Q_4
 - E5 - Flat battery

Should the display go completely blank, check the battery voltage – it should be higher than 3V. Replace defective or flat battery using the procedure described in Section 8.6. Should battery replacement not help, send the meter back to the manufacturer for repair.

8.6. Battery lifetime and replacement

The power for the electronic control unit is supplied by two battery sources:

Batteries B3 and B4 – alkali batteries MN1604 9V / 550 mAh

Battery B2 – Li battery SAFT LITHIUM 3.6V / 16.5 Ah (type designation LS 33600)

The guaranteed battery lifetime is 4 years. After expiry of the specified lifetime, all batteries should be replaced at the same time.

In case of need or on the customer's request, smaller battery SAFT LITHIUM 3.6V / 3.6 Ah (type designation LSH 14 light) containing less than 1g of lithium can be used instead of battery B2 above. The manufacturer supplies this battery with a plastic cover fitting into the holder of the original (larger) battery. The lifetime of the LSH 14 battery is 1 year counted from the day of dispatch. It can be at any time replaced by the original battery of capacity 16.5 Ah.

To access the battery compartment, pull out the locking pin in the direction indicated by arrow in Fig. 43 and then lift off the front panel of the electronic unit from the right side. The locking pin is held in position by company seals (see the dimensional drawing in Section 3.3.2). During the battery replacement operation the measurements will be interrupted but all current data including those on the total fluid volume will be retained in the meter memory. Replace batteries one at a time, starting with B2 followed by B3 and B4.

WARNING: Incorrect battery polarity may cause damage to the electronic unit circuits.

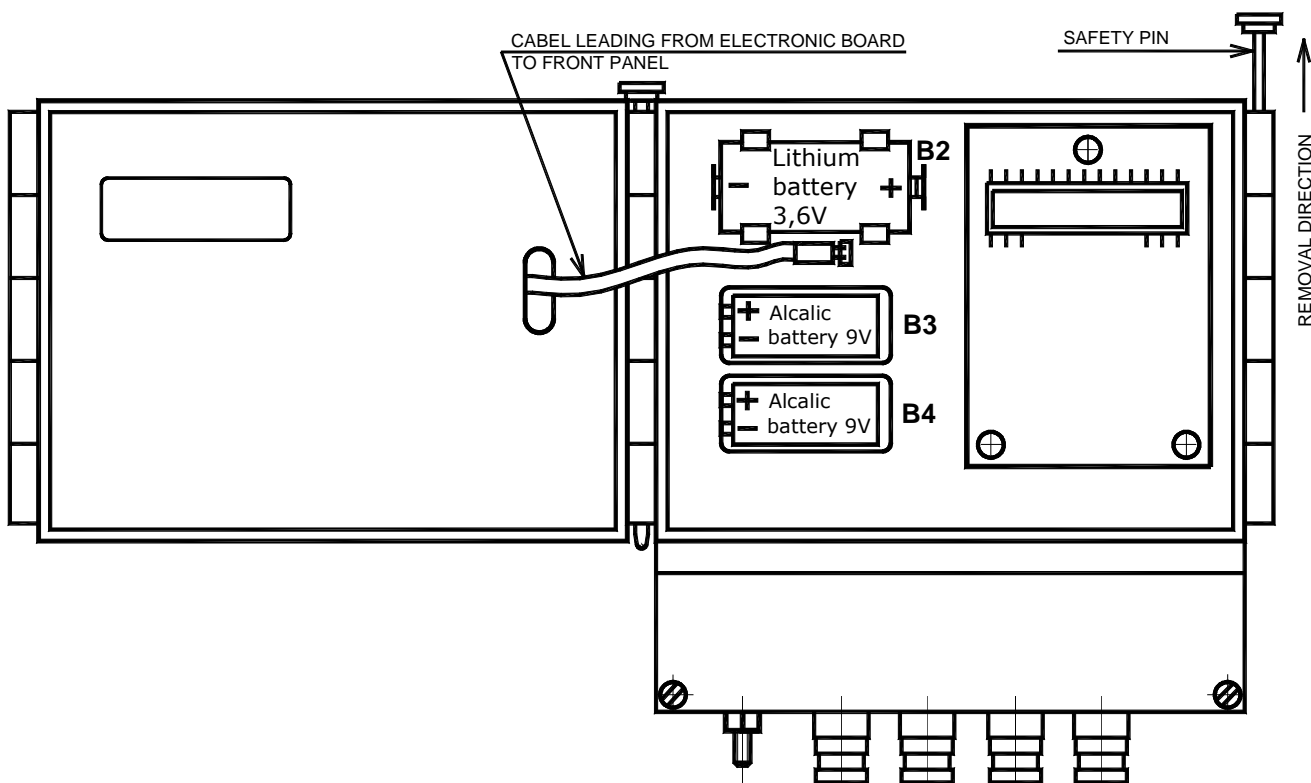



Fig. 43 Battery replacement

Check the correct placement and fit of batteries in their respective holders. The meter should resume operation with the measured values shown on the display and no errors indicated. Should error E5 be indicated, recheck the correct fitting of all batteries and their voltage. Also check the flat-cable connection between the PC board and the front panel of the electronic unit. Depress the push button at the front panel and make sure that the mode-switching function works. Then push the front panel back and secure its position by locking pin. Make sure that the electronic unit box is properly closed and sealed as required by the IP65 specifications. Replace the seals on the locking pin.

 ELIS PLZEŇ a. s.	Product application, installation and service manual	Page 37 of 40
	FLOMIC FL 3005 – battery-powered ultrasonic flow meter for direct installation in piping	

9. WARRANTY AND POST-WARRANTY SERVICES

9.1. Warranty services

Warranty services include product repairs performed free of charge within the warranty period either by the manufacturer or a duly authorised partner service centre.

Product repair is performed free of charge in the cases where the product defect has been identified as caused by defective material, component part or non-standard workmanship within the specified warranty period.

Should a product be found irreparable due to the above reasons, it will be replaced free of charge.

Warranty services shall be provided either directly by the manufacturer (ELIS PLZEŇ a.s.) or a duly authorised service centre or product distributor (provided these have been duly trained to perform such activities and can prove their capabilities by a certificate in writing).

Warranty services are not applicable to:

- products with broken factory or metrological seals;
 - products with defects caused by incorrect product assembly/installation;
 - products with defects caused by non-standard product application or use;
 - the cases of alienated or stolen products;
 - product defects caused due to force majeure circumstances or elementary disaster.

Requirements for warranty services shall be communicated to the manufacturer in writing (by e-mail, fax or registered letter).

Should the manufacturer not acknowledge the warranty claim, this fact will be made known to the customer in writing whereby the product repair costs will be invoiced to the customer.

9.2. Post-warranty services

Post-warranty services include any and all product repairs where the subject defects originated after expiry of the agreed warranty term. Such services (whether performed at the manufacturer's premises or anywhere else as directed by the customer) will be invoiced by the manufacturer to the customer.

In the cases of commercial (invoicing) meters, each repair action shall be followed by metrological verification of specified meter parameters by an authorised metrological centre.

Requirements for post-warranty services shall be communicated to the manufacturer in writing (by e-mail, fax or registered letter).

10. TESTING

While in production, each flow-meter system component is subject to quality control procedures in observance of internal quality assurance directives of the manufacturer. Finished products are subject to checks on completeness and final quality tests including a 15-hour burn-in operational test.

11. PACKAGING

Unless agreed otherwise with the customer, the company products are packaged in compliance with the standard requirements regarding domestic and international transport. The packaging procedures are performed in observance of the manufacturer's internal directives.

12. PRODUCT ACCEPTANCE

The product acceptance procedure consists of visual inspection of the delivered product and check on its completeness in reference to the delivery note.

As specified in to the product order, the delivery kit shall include the complete FL 3005 meter system, product assembly and measuring fixtures and tooling (optional equipment), Product Application, Installation and Service Manual, product compliance certificate and the respective delivery note.

13. WARRANTY TERM AND CONDITIONS

Unless agreed otherwise with the customer, the warranty term for the FL 3005 ultrasonic meter is 12 months counted from the date of sale. Any meter failures within the warranty period due to defective materials, parts or non-standard workmanship will be repaired free of charge. The warranty period shall be extended by the time the meter was inoperative due to a warranty repair. Manufacturer's warranty shall not be applicable to product failures due to incorrect assembly and/or installation, operation, wilful damage, theft, alienation or events classified as force majeure.

**14. ORDERING PROCEDURE**

To order a FL 3005 ultrasonic flow meter, use the correct ordering code number identified in reference to the following table.

Position within ordering code No.	1	2	3	4	5	6	-	7	8	9	10	11	12	13	14
ORDERING NUMBER	F	L	3	0	0	5	-								
TECHNICAL PARAMETERS															
Sensor dimension DN [mm]	200							0	1						
	250							0	2						
	300							0	3						
	350							0	4						
	400							0	5						
	450							0	6						
	500							0	7						
	600							0	8						
	700							0	9						
	800							1	0						
	900							1	1						
	1,000							1	2						
	1,200							1	3						
	1,400							1	4						
	1,600							1	5						
1,800							1	6							
2,000							1	7							
Piping material	carbon steel									1					
	stainless steel									2					
Probe protection class	IP 54										1				
	IP 68										2				
Current output	yes											1			
	no											2			
Data communication system	no communication												1		
	data archiving function												2		
	data storage + optical probe												3		
	data storage + RS 232												4		
	data storage + GSM module												5		
Cable length [m]	3														1
	5														2
	10														3
	20														4
	another (not exceeding 20m)														0
Assembly fixtures/tooling	yes														1
	no														2



ELIS PLZEŇ a. s.

Product application, installation and service manual
FLOMIC FL 3005 – battery-powered ultrasonic flow meter
for direct installation in piping

Position within ordering code No.		-	15	16	17	18	19	20	21	22
ORDERING NUMBER										
COMMERCIAL CONDITIONS										
Quantity	1 piece		0	0	1					
	2 pieces		0	0	2					
	3 pieces		0	0	3					
					
					
					
	999 pieces		9	9	9					
	1,000 pieces / more		0	0	0					
User manual language	Czech						1			
	English						2			
Packaging	no packaging							1		
	standard/domestic							2		
	for export							3		
	special							0		
Delivery	collected personally								1	
	shipping agent at supplier's costs								2	
	shipping agent at customer's costs								3	
	special								0	
Warranty term	12 months									2
	18 months									3
	24 months									4
	36 months									5
	special									0
User manual id. number to be referred to as the background material for determination of the ordering number	Es 90 368 K									1

 ELIS PLZEŇ a. s.	Product application, installation and service manual	Page 40 of 40
	FLOMIC FL 3005 – battery-powered ultrasonic flow meter for direct installation in piping	

Manufacturer's address:

ELIS PLZEŇ a. s.
Luční 15, P. O. BOX 126
304 26 Plzeň
Czech Republic
Tel.: +420/377 517 711
Fax: +420/377 517 722
E-mail: sales@elis.cz
<http://www.elis.cz>

Issue No. 2