

Introduction

Motion control, in its widest sense, could relate to anything from a welding robot to the hydraulic system in a mobile crane. In the field of Electronic Motion Control, we are primarily concerned with systems falling within a limited power range, typically up to about 10HP (7KW), and requiring precision in one or more aspects. This may involve accurate control of distance or speed, very often both, and sometimes other parameters such as torque or acceleration rate. In the case of the two examples given, the welding robot requires precise control of both speed and distance; the crane hydraulic system uses the driver as the feedback system so its accuracy varies with the skill of the operator. This wouldn't be considered a motion control system in the strict sense of the term.

Our standard motion control system consists of three basic elements:

Fig. 1 Elements of motion control system

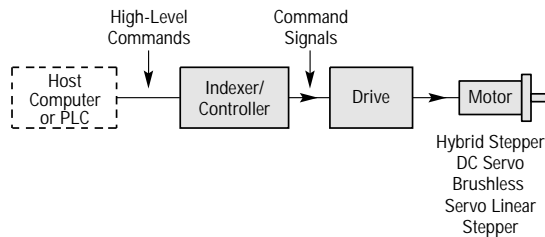

The motor. This may be a stepper motor (either rotary or linear), a DC brush motor or a brushless servo motor. The motor needs to be fitted with some kind of feedback device unless it is a stepper motor.

Fig. 2 shows a system complete with feedback to control motor speed. Such a system is known as a *closed-loop velocity servo system*.

Fig. 2 Typical closed loop (velocity) servo system

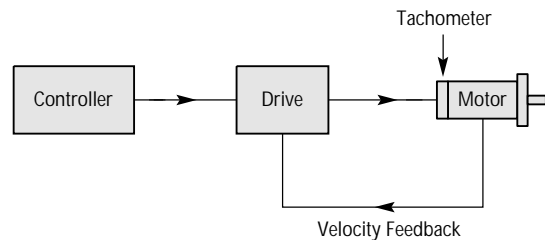

The drive. This is an electronic power amplifier that delivers the power to operate the motor in response to low-level control signals. In general, the drive will be specifically designed to operate with a particular motor type – you can't use a stepper drive to operate a DC brush motor, for instance.

The control system. The actual task performed by the motor is determined by the indexer/controller; it sets things like speed, distance, direction and acceleration rate. The control function may be distributed between a host controller, such as a desktop computer, and a slave unit that accepts high-level commands. One controller may operate in conjunction with several drives and motors in a multi-axis system.

We'll be looking at each of these system elements as well as their relationships to each other.

Table of Contents

Motor Applications	A3
Step Motor Technology	A4
Linear Step Motor Technology	A9
Common Questions Regarding Step Motors	A12
DC Brush Motor Technology	A13
Brushless Motor Technology	A17
Hybrid Servo Technology	A20
Direct Drive Motor Technology	A21
Step Motor Drive Technology	A23
Microstepping Drive Technology	A29
Analog and Digital Servo Drives	A31
Brushless Servo Drive Technology	A34
Servo Tuning	A36
Feedback Devices	A39
Machine Control	A45
Control System Overview	A46
Understanding I/O Modules	A48
Serial & Parallel Communications	A51
Electrical Noise Symptoms & Solutions	A52
Emergency Stop	A54
System Selection Considerations	A55
Motor Sizing and Selection Software	A57
System Calculations – Move Profiles	A58
System Calculations – Leadscrew Drives	A60
System Calculations – Direct Drives	A63
System Calculations – Gear Drives	A64
System Calculations – Tangential Drives	A65
System Calculations – Linear Motors	A66
Glossary of Terms	A68
Technical Data	A71
Application Examples	A72

Application Areas of Motor Types

The following section gives some idea of the applications that are particularly appropriate for each motor type, together with certain applications that are best avoided. It should be stressed that there is a wide range of applications that can be equally well met by more than one motor type, and the choice will tend to be dictated by customer preference, previous experience or compatibility with existing equipment.

Cost-conscious applications will always be worth attempting with a stepper, as it will generally be hard to beat the stepper's price. This is particularly true when the dynamic requirements are not severe, such as "setting" type applications like positioning a guillotine back-stop or a print roller.

High-torque, low-speed, continuous-duty applications are also appropriate for step motors. At low speeds, it is very efficient in terms of torque output relative to both size and input power. Microstepping can improve low-speed applications such as a metering pump drive for very accurate flow control.

High-torque, high-speed, continuous-duty applications suit the servo motor, and in fact, a step motor should be avoided in such applications because the high-speed losses can cause excessive motor heating. A DC motor can deliver greater continuous shaft power at high speeds than a stepper of the same frame size.

Short, rapid, repetitive moves are the natural domain of steppers or hybrid servos due to their high torque at low speeds, good torque-to-inertia ratio and lack of commutation problems. The brushes of the DC motor can limit its potential for frequent starts, stops and direction changes.

Low-friction, mainly inertial loads can be efficiently handled by the DC servo provided the start/stop duty requirements are not excessive. This type of load requires a high ratio of peak to continuous torque and in this respect the servo motor excels.

Very arduous applications with a high dynamic duty cycle or requiring very high speeds may require a brushless motor. This solution may also be dictated when maintenance-free operation is necessary.

Low-speed, high-smoothness applications are appropriate for microstepping or direct drive servos.

Applications in hazardous environments or in a vacuum may not be able to use a brush motor. Either a stepper or a brushless motor is called for, depending on the demands of the load. Bear in mind that heat dissipation may be a problem in a vacuum when the loads are excessive.

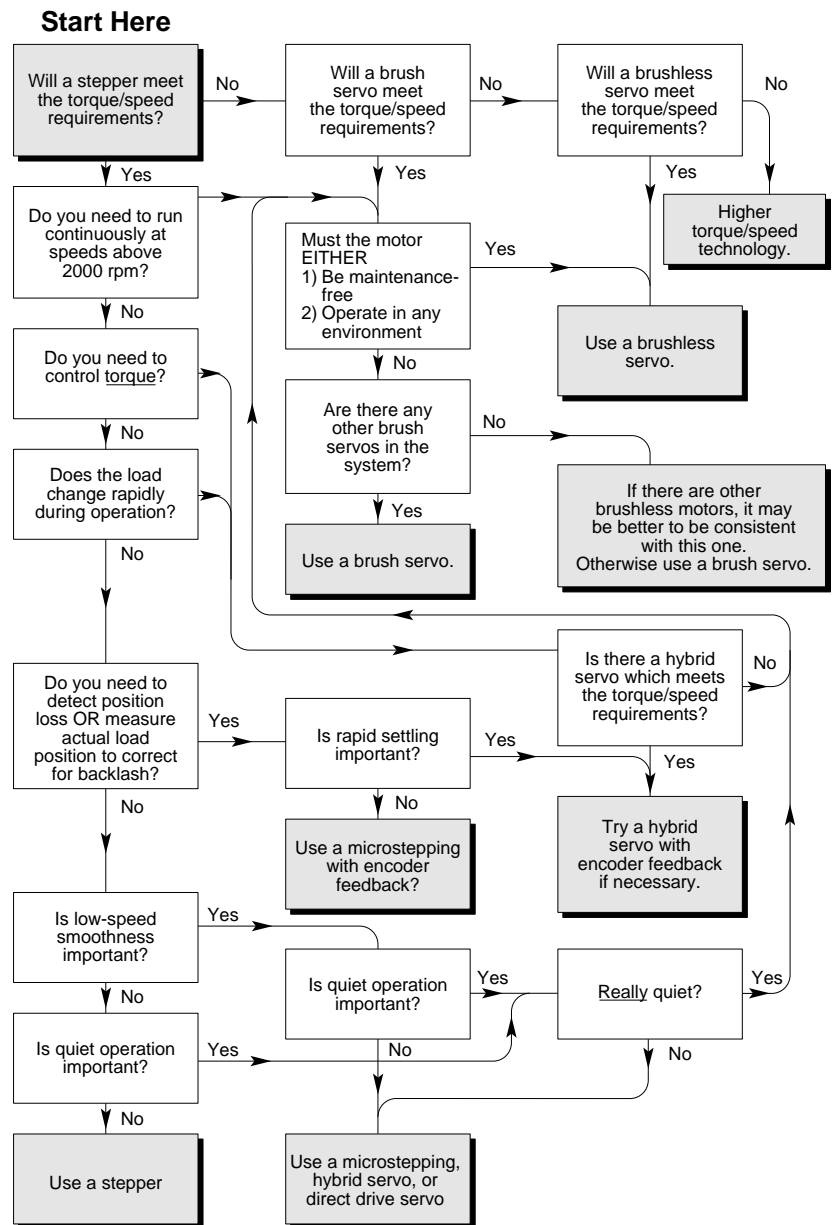

Stepper Motors

Stepper Motor Benefits

Stepper motors have the following benefits:

- Low cost
- Ruggedness
- Simplicity in construction
- High reliability
- No maintenance
- Wide acceptance
- No tweaking to stabilize
- No feedback components are needed
- They work in just about any environment
- Inherently more failsafe than servo motors.

There is virtually no conceivable failure within the stepper drive module that could cause the motor to run away. Stepper motors are simple to drive and control in an open-loop configuration. They only require four leads. They provide excellent torque at low speeds, up to 5 times the continuous torque of a brush motor of the same frame size or double the torque of the equivalent brushless motor. This often eliminates the need for a gearbox. A stepper-driven system is inherently stiff, with known limits to the dynamic position error.

Permanent Magnet (P.M.) Motors. The tin-can or “canstack” motor shown in Fig. 1.1 is perhaps the most widely-used type in non-industrial applications. It is essentially a low-cost, low-torque, low-speed device ideally suited to applications in fields such as computer peripherals. The motor construction results in relatively large step angles, but their overall simplicity lends itself to economic high-volume production at very low cost. The axial-air gap or disc motor is a variant of the permanent magnet design which achieves higher performance, largely because of its very low rotor inertia. However this does restrict the applications of the motor to those involving little inertia. (e.g., positioning the print wheel in a daisy-wheel printer).

Fig. 1.1 “Canstack” or permanent magnet motor

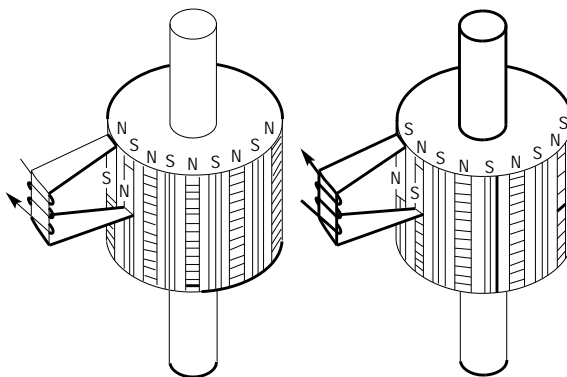

Stepper Motor Disadvantages

Stepper motors have the following disadvantages:

- Resonance effects and relatively long settling times
- Rough performance at low speed unless a microstep drive is used
- Liability to undetected position loss as a result of operating open-loop
- They consume current regardless of load conditions and therefore tend to run hot
- Losses at speed are relatively high and can cause excessive heating, and they are frequently noisy (especially at high speeds).
- They can exhibit lag-lead oscillation, which is difficult to damp. There is a limit to their available size, and positioning accuracy relies on the mechanics (e.g., ballscrew accuracy). Many of these drawbacks can be overcome by the use of a closed-loop control scheme.

Note: The Compumotor Zeta Series minimizes or reduces many of these different stepper motor disadvantages.

There are three main stepper motor types:

- Permanent Magnet (P.M.) Motors
- Variable Reluctance (V.R.) Motors
- Hybrid Motors

Variable Reluctance (V.R.) Motors. There is no permanent magnet in a V.R. motor, so the rotor spins freely without “detent” torque. Torque output for a given frame size is restricted, although the torque-to-inertia ratio is good, and this type of motor is frequently used in small sizes for applications such as micro-positioning tables. V.R. motors are seldom used in industrial applications (having no permanent magnet). They are not sensitive to current polarity and require a different driving arrangement than the other motor types.

Fig. 1.2 Variable reluctance motor

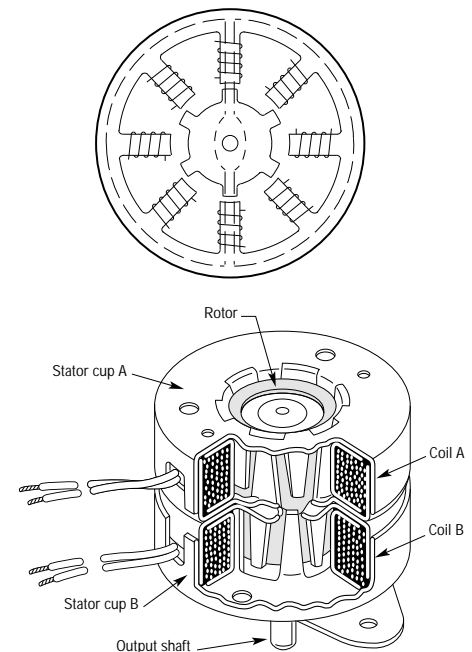

Courtesy Airpax Corp., USA

Hybrid Motors. The hybrid motor shown in Fig. 1.3 is by far the most widely-used stepper motor in industrial applications. The name is derived from the fact that it combines the operating principles of the other two motor types (P.M. & V.R.). Most hybrid motors are 2-phase, although 5-phase versions are available. A recent development is the “enhanced hybrid” motor, which uses flux-focusing magnets to give a significant improvement in performance, albeit at extra cost.

Fig. 1.3 Hybrid stepper motor

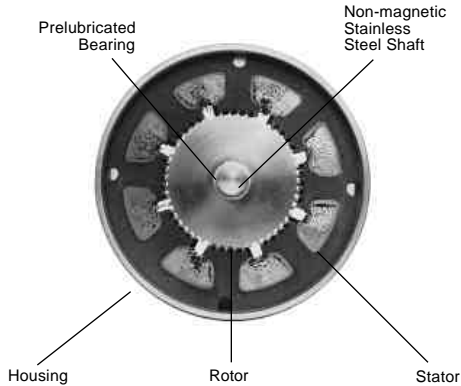

The operation of the hybrid motor is most easily understood by looking at a very simple model that will produce 12 steps per rev. (Fig. 1.4).

Fig. 1.4 Simple 12 step/rev hybrid motor

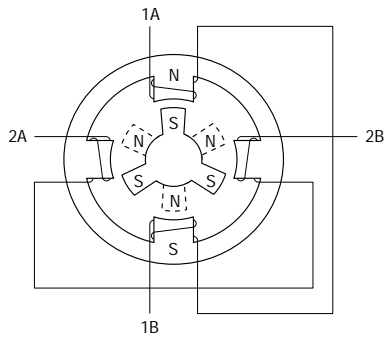

The rotor of this machine consists of two pole pieces with three teeth on each. In between the pole pieces is a permanent magnet that is magnetized along the axis of the rotor, making one end a north pole and the other a south pole. The teeth are offset at the north and south ends as shown in the diagram.

The stator consists of a shell having four teeth that run the full length of the rotor. Coils are wound on the stator teeth and are connected together in pairs.

With no current flowing in any of the motor windings, the rotor will take one of the positions shown in the diagrams. This is because the permanent magnet in the rotor is trying to minimize the reluctance (or “magnetic resistance”) of the flux path from one end to the other. This will occur when a pair of north and south pole rotor teeth are aligned with two of the stator poles. The torque tending to hold the rotor in one of these positions is usually small and is called the “detent torque”. The motor shown will have 12 possible detent positions.

If current is now passed through one pair of stator windings, as shown in Fig. 1.5(a), the resulting north and south stator poles will attract teeth of the opposite polarity on each end of the rotor. There are now only three stable positions for the rotor, the same as the number of rotor teeth. The torque required to deflect the rotor from its stable position is now much greater, and is referred to as the “holding torque”.

Fig. 1.5 Full stepping, one phase on

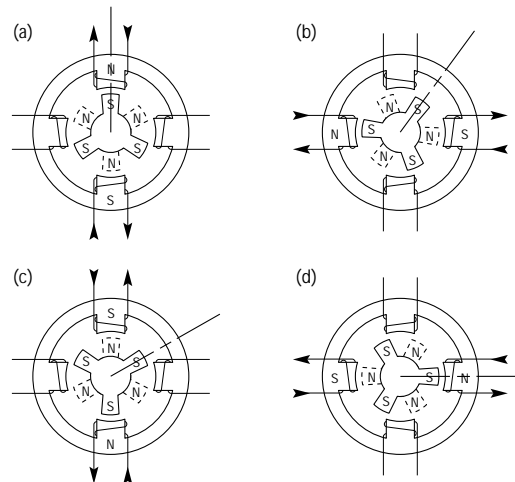

By changing the current flow from the first to the second set of stator windings (b), the stator field rotates through 90° and attracts a new pair of rotor poles. This results in the rotor turning through 30°, corresponding to one full step. Reverting to the first set of stator windings but energizing them in the opposite direction, we rotate the stator field through another 90° and the rotor takes another 30° step (c). Finally, the second set of windings are energized in the opposite direction (d) to give a third step position. We can now go back to the first condition (a), and after these four steps the rotor will have moved through one tooth pitch. This simple motor therefore performs 12 steps per rev. Obviously, if the coils are energized in the reverse sequence, the motor will go round the other way.

If two coils are energized simultaneously (Fig. 1.6), the rotor takes up an intermediate position since it is equally attracted to two stator poles. Greater torque is produced under these conditions because all the stator poles are influencing the rotor. The motor can be made to take a full step simply by reversing the current in one set of windings; this causes a 90° rotation of the stator field as before. In fact, this would be the normal way of driving the motor in the full-step mode, always keeping two windings energized and reversing the current in each winding alternately.

Fig. 1.6 Full stepping, two phase on

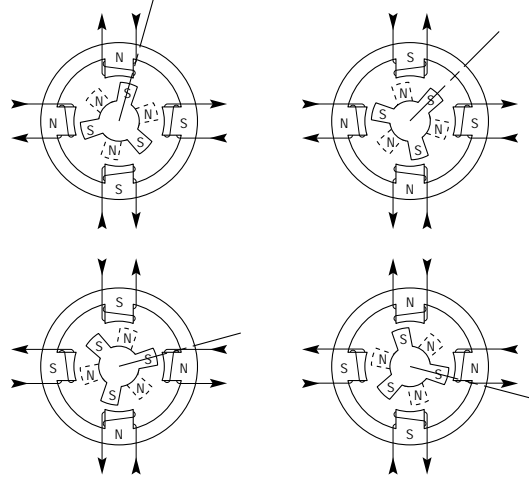

By alternately energizing one winding and then two (Fig. 1.7), the rotor moves through only 15° at each stage and the number of steps per rev will be doubled. This is called half stepping, and most industrial applications make use of this stepping mode. Although there is sometimes a slight loss of torque, this mode results in much better smoothness at low speeds and less overshoot and ringing at the end of each step.

Fig. 1.7 Half stepping

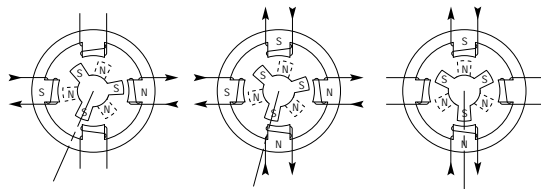

Current Patterns in the Motor Windings

When the motor is driven in its full-step mode, energizing two windings or “phases” at a time (see Fig. 1.8), the torque available on each step will be the same (subject to very small variations in the

motor and drive characteristics). In the half-step mode, we are alternately energizing two phases and then only one as shown in Fig. 1.9. Assuming the drive delivers the same winding current in each case, this will cause greater torque to be produced when there are two windings energized. In other words, alternate steps will be strong and weak. This does not represent a major deterrent to motor performance—the available torque is obviously limited by the weaker step, but there will be a significant improvement in low-speed smoothness over the full-step mode.

Clearly, we would like to produce approximately equal torque on every step, and this torque should be at the level of the stronger step. We can achieve this by using a higher current level when there is only one winding energized. This does not over-dissipate the motor because the manufacturer’s current rating assumes two phases to be energized (the current rating is based on the allowable case temperature). With only one phase energized, the same total power will be dissipated if the current is increased by 40%. Using this higher current in the one-phase-on state produces approximately equal torque on alternate steps (see Fig. 1.10).

Fig. 1.8 Full step current, 2-phase on

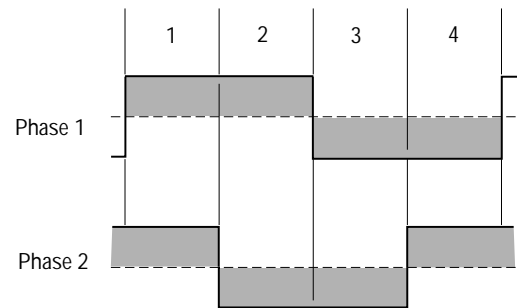

Fig. 1.9 Half step current

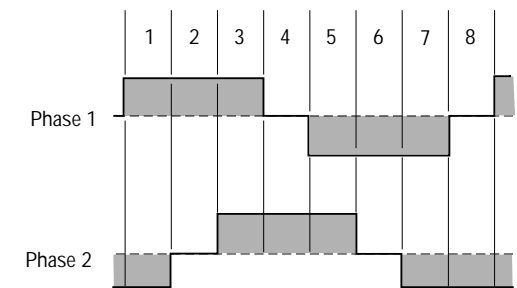
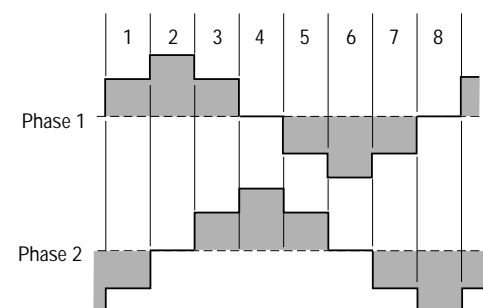
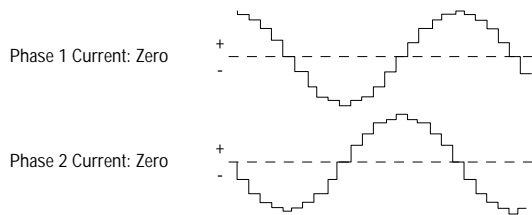

Fig. 1.10 Half step current, profiled



We have seen that energizing both phases with equal currents produces an intermediate step position half-way between the one-phase-on positions. If the two phase currents are unequal, the rotor position will be shifted towards the stronger pole. This effect is utilized in the microstepping drive, which subdivides the basic motor step by proportioning the current in the two windings. In this way, the step size is reduced and the low-speed smoothness is dramatically improved. High-resolution microstep drives divide the full motor step into as many as 500 microsteps, giving 100,000 steps per revolution. In this situation, the current pattern in the windings closely resembles two sine waves with a 90° phase shift between them (see Fig. 1.11). The motor is now being driven very much as though it is a conventional AC synchronous motor. In fact, the stepper motor can be driven in this way from a 60 Hz-US (50Hz-Europe) sine wave source by including a capacitor in series with one phase. It will rotate at 72 rpm.

Fig. 1.11 Phase currents in microstep mode



Standard 200-Step Hybrid Motor

The standard stepper motor operates in the same way as our simple model, but has a greater number of teeth on the rotor and stator, giving a smaller basic step size. The rotor is in two sections as before, but has 50 teeth on each section. The half-tooth displacement between the two sections is retained. The stator has 8 poles each with 5 teeth, making a total of 40 teeth (see Fig. 1.12).

Fig. 1.12 200-step hybrid motor

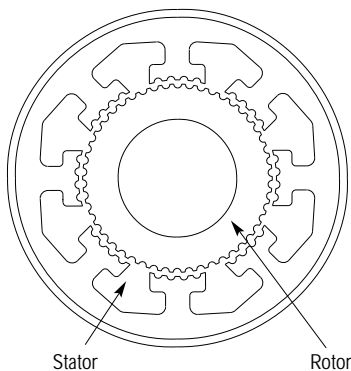

If we imagine that a tooth is placed in each of the gaps between the stator poles, there would be a total of 48 teeth, two less than the number of rotor teeth. So if rotor and stator teeth are aligned at 12 o'clock, they will also be aligned at 6 o'clock. At 3 o'clock and 9 o'clock the teeth will be misaligned. However, due to the displacement between the sets of rotor teeth, alignment will occur at 3 o'clock and 9 o'clock at the other end of the rotor.

The windings are arranged in sets of four, and wound such that diametrically-opposite poles are the same. So referring to Fig. 1.12, the north poles at 12 and 6 o'clock attract the south-pole teeth at the front of the rotor; the south poles at 3 and 9 o'clock attract the north-pole teeth at the back. By switching current to the second set of coils, the stator field pattern rotates through 45°. However, to align with this new field, the rotor only has to turn through 1.8°. This is equivalent to one quarter of a tooth pitch on the rotor, giving 200 full steps per revolution.

Note that there are as many detent positions as there are full steps per rev, normally 200. The detent positions correspond with rotor teeth being fully aligned with stator teeth. When power is applied to a stepper drive, it is usual for it to energize in the "zero phase" state in which there is current in both sets of windings. The resulting rotor position does not correspond with a natural detent position, so an unloaded motor will always move by at least one half step at power-on. Of course, if the system was turned off other than in the zero phase state, or the motor is moved in the meantime, a greater movement may be seen at power-up.

Another point to remember is that for a given current pattern in the windings, there are as many stable positions as there are rotor teeth (50 for a 200-step motor). If a motor is de-synchronized, the resulting positional error will always be a whole number of rotor teeth or a multiple of 7.2°. A motor cannot "miss" individual steps – position errors of one or two steps must be due to noise, spurious step pulses or a controller fault.

Bifilar Windings

Most motors are described as being “bifilar wound”, which means there are two identical sets of windings on each pole. Two lengths of wire are wound together as though they were a single coil. This produces two windings that are electrically and magnetically almost identical – if one coil were to be wound on top of the other, even with the same number of turns, the magnetic characteristics would be different. In simple terms, whereas almost all the flux from the inner coil would flow through the iron core, some of the flux from the outer coil would flow through the windings of the coil underneath.

The origins of the bifilar winding go back to the unipolar drive (see Drive Technologies section, page A23). Rather than have to reverse the current in one winding, the field may be reversed by transferring current to a second coil wound in the opposite direction. (Although the two coils are wound the same way, interchanging the ends has the same effect.) So with a bifilar-wound motor, the drive can be kept simple. However, this requirement has now largely disappeared with the widespread availability of the more-efficient bipolar drive. Nevertheless, the two sets of windings do give us additional flexibility, and we shall see that different connection methods can be used to give alternative torque-speed characteristics.

If all the coils in a bifilar-wound motor are brought out separately, there will be a total of 8 leads (see Fig. 1.13). This is becoming the most common configuration since it gives the greatest flexibility. However, there are still a number of motors produced with only 6 leads, one lead serving as a common connection to each winding in a bifilar pair. This arrangement limits the motor’s range of application since the windings cannot be connected in parallel. Some motors are made with only 4 leads, these are not bifilar-wound and cannot be used with a unipolar drive. There is obviously no alternative connection method with a 4-lead motor, but in many applications this is not a drawback and the problem of insulating unused leads is avoided.

Fig. 1.13 Motor lead configurations

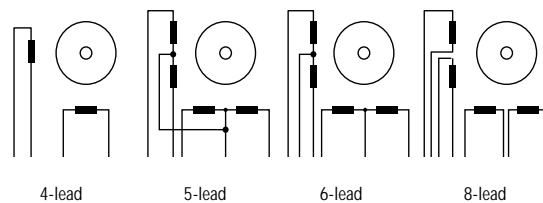

Occasionally a 5-lead motor may be encountered. These are not recommended since they cannot be used with conventional bipolar drives requiring electrical isolation between the phases.

Looking at the motor longitudinal section (Fig. 1.14), we can see the permanent magnet in the rotor and the path of the flux through the pole pieces and the stator. The alternating flux produced by the stator windings flows in a plane at right angles to the page. Therefore, the two flux paths are at right

angles to each other and only interact in the rotor pole pieces. This is an important feature of the hybrid motor – it means that the permanent magnet in the rotor does not “see” the alternating field from the windings, hence it does not produce a demagnetizing effect. Unlike the DC servo motor, it is generally impossible to de-magnetize a stepper motor by applying excess current. However, too much current will damage the motor in other ways. Excessive heating may melt the insulation or the winding formers, and may soften the bonding material holding the rotor laminations. If this happens and the laminations are displaced, the effects can be the same as if the rotor had been de-magnetized

Fig. 1.14 Longitudinal section through single stack motor

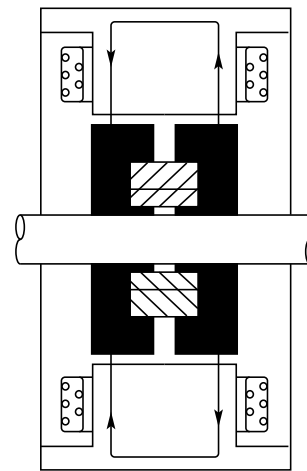

Fig. 1.14 also shows that the rotor flux only has to cross a small air gap (typically 0.1mm or 0.004”) when the rotor is in position. By magnetizing the rotor after assembly, a high flux density is obtained that can be largely destroyed if the rotor is removed. Stepper motors should therefore not be dismantled purely to satisfy curiosity, since the useful life of the motor will be terminated.

Because the shaft of the motor passes through the center of the permanent magnet, a non-magnetic material must be used to avoid a magnetic short-circuit. Stepper shafts are therefore made of stainless steel, and should be handled with care. Small-diameter motors are particularly vulnerable if they are dropped on the shaft end, as this will invariably bend the shaft.

To produce a motor with a higher torque output, we need to increase the strength of both the permanent magnet in the rotor and the field produced by the stator. A stronger rotor magnet can be obtained by increasing the diameter, giving us a larger cross-sectional area. However, increasing the diameter will degrade the acceleration performance of the motor because the torque-to-inertia ratio worsens (to a first approximation, torque increases with diameter squared but inertia goes up by the fourth power). Nevertheless, we can increase torque output without degrading acceleration performance by

adding further magnet sections or “stacks” to the same shaft (Fig. 1.15). A second stack will enable twice the torque to be produced and will double the inertia, so the torque-to-inertia ratio remains the same. Hence, stepper motors are produced in single-, two- and three-stack versions in each frame size.

Fig. 1.15 Three-stack hybrid stepping motor

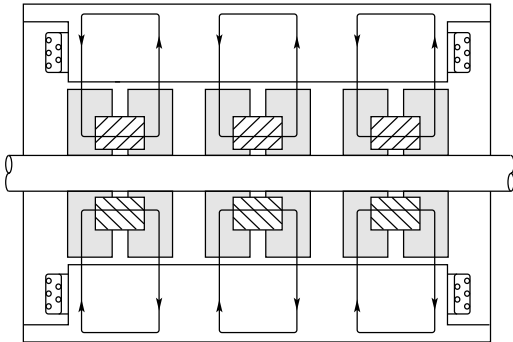

As a guideline, the torque-to-inertia ratio reduces by a factor of two with each increase in frame size (diameter). So an unloaded 34-size motor can accelerate twice as rapidly as a 42-size, regardless of the number of stacks.

Linear Stepping Motors

Fig. 1.16 Linear stepping motor

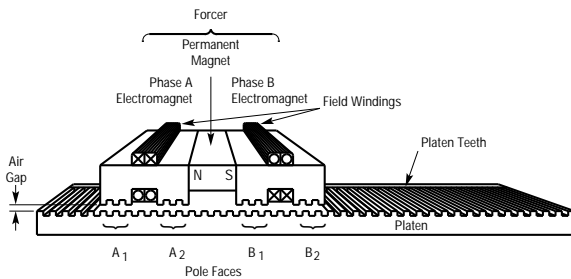

The linear stepper is essentially a conventional rotary stepper that has been “unwrapped” so that it operates in a straight line. The moving component is referred to as the forcer and it travels along a fixed element or platen. For operational purposes, the platen is equivalent to the rotor in a normal stepper, although it is an entirely passive device and has no permanent magnet. The magnet is incorporated in the moving forcer together with the coils (see Fig. 1.16).

The forcer is equipped with 4 pole pieces each having 3 teeth. The teeth are staggered in pitch with respect to those on the platen, so that switching the current in the coils will bring the next set of teeth into alignment. A complete switching cycle (4 full steps) is equivalent to one tooth pitch on the platen. Like the rotary stepper, the linear motor can be driven from a microstep drive. In this case, a typical linear resolution will be 12,500 steps per inch.

The linear motor is best suited for applications that require a low mass to be moved at high speed. In a leadscrew-driven system, the predominant inertia is usually the leadscrew rather than the load to be moved. Hence, most of the motor torque goes to accelerate the leadscrew, and this problem becomes more severe the longer the travel required. Using a linear motor, all the developed force is applied directly to the load and the performance achieved is independent of the length of the move. A screw-driven system can develop greater linear force and better stiffness; however, the maximum speed may be as much as ten times higher with the equivalent linear motor. For example, a typical maximum speed for a linear motor is 100 in/sec. To achieve this with a 10-pitch ballscrew would require a rotary speed of 6,000 rpm. In addition, the linear motor can travel up to 12 feet using a standard platen.

How the Linear Motor Works

The forcer consists of two electromagnets (A and B) and a strong rare earth permanent magnet. The two pole faces of each electromagnet are toothed to concentrate the magnetic flux. Four sets of teeth on the forcer are spaced in quadrature so that only one set at a time can be aligned with the platen teeth.

The magnetic flux passing between the forcer and the platen gives rise to a very strong force of attraction between the two pieces. The attractive force can be up to 10 times the peak holding force of the motor, requiring a bearing arrangement to maintain precise clearance between the pole faces and platen teeth. Either mechanical roller bearings or air bearings are used to maintain the required clearance.

When current is established in a field winding, the resulting magnetic field tends to reinforce permanent magnetic flux at one pole face and cancel it at the other. By reversing the current, the reinforcement and cancellation are exchanged. Removing current divides the permanent magnetic flux equally between the pole faces. By selectively applying current to phase A and B, it is possible to concentrate flux at any of the forcer’s four pole faces. The face receiving the highest flux concentration will attempt to align its teeth with the platen. Fig. 1.17 shows the four primary states or full steps of the forcer. The four steps result in motion of one tooth interval to the right. Reversing the sequence moves the forcer to the left.

Repeating the sequence in the example will cause the forcer to continue its movement. When the sequence is stopped, the forcer stops with the appropriate tooth set aligned. At rest, the forcer develops a holding force that opposes any attempt to displace it. As the resting motor is displaced from equilibrium, the restoring force increases until the displacement reaches one-quarter of a tooth interval. (See Fig. 1.18.) Beyond this point, the restoring force drops. If the motor is pushed over the crest of its holding force, it slips or jumps rather sharply and comes to rest at an integral number of tooth intervals away from its original location. If this occurs while the forcer is travelling along the platen, it is referred to as a stall condition.

Fig. 1.17 The four cardinal states or full steps of the forcer

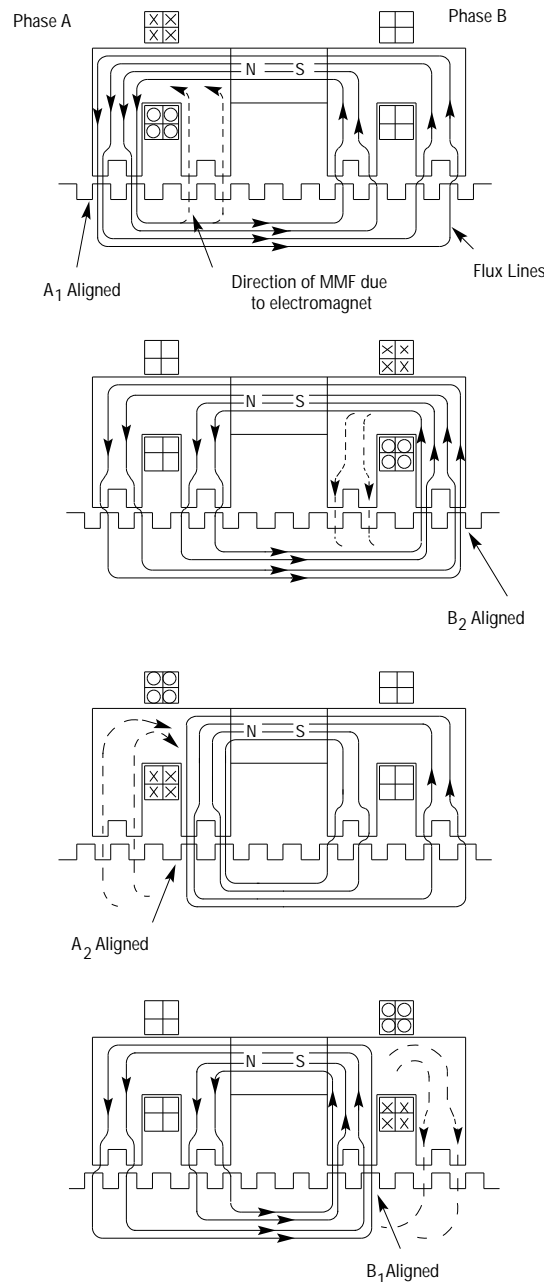

Step Motor Characteristics

There are numerous step motor performance characteristics that warrant discussion. However, we'll confine ourselves to those traits with the greatest practical significance.

Fig. 1.18 illustrates the static torque curve of the hybrid step motor. This relates to a motor that is energized but stationary. It shows us how the restoring torque varies with rotor position as it is deflected from its stable point. We're assuming that there are no frictional or other static loads on the motor. As the rotor moves away from the stable position, the torque steadily increases until it reaches a maximum after one full step (1.8°). This maximum value is called the holding torque and it represents the largest static load that can be applied to the shaft without causing continuous rotation. However, it doesn't tell us the maximum running torque of the motor – this is always less than the holding torque (typically about 70%).

Fig. 1.18 Static torque-displacement characteristic

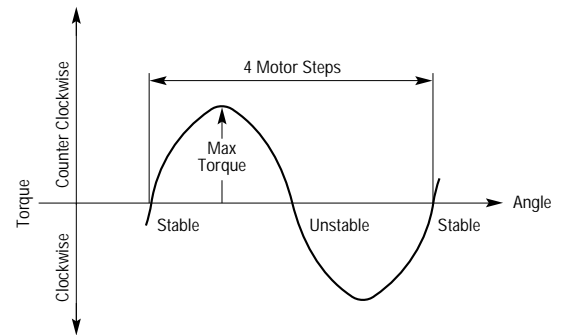

As the shaft is deflected beyond one full step, the torque will fall until it is again at zero after two full steps. However, this zero point is unstable and the torque reverses immediately beyond it. The next stable point is found four full steps away from the first, equivalent to one tooth pitch on the rotor or 1/50 of a revolution.

Although this static torque characteristic isn't a great deal of use on its own, it does help explain some of the effects we observe. For example, it indicates the static stiffness of the system, (i.e., how the shaft position changes when a torque load is applied to a stationary motor). Clearly the shaft must deflect until the generated torque matches the applied load. If the load varies, so too will the static position. Non-cumulative position errors will therefore result from effects such as friction or out-of-balance torque loads. It is important to remember that the static stiffness is not improved by using a microstepping drive—a given load on the shaft will produce the same angular deflection. So while microstepping increases resolution and smoothness, it may not necessarily improve positioning accuracy.

Under dynamic conditions with the motor running, the rotor must be lagging behind the stator field if it is producing torque. Similarly, there will be a lead situation when the torque reverses during deceleration. Note that the lag and lead relate only to position and not to speed. From the static torque curve (Fig. 1.18), clearly this lag or lead cannot exceed two full steps (3.6°) if the motor is to retain synchronism. This limit to the position error can make the stepper an attractive option in systems where dynamic position accuracy is important.

When the stepper performs a single step, the nature of the response is oscillatory as shown in Fig. 1.19. The system can be likened to a mass that is located by a "magnetic spring", so the behavior resembles the classic mass-spring characteristic. Looking at it in simple terms, the static torque curve indicates that during the step, the torque is positive during the full forward movement and so is accelerating the rotor until the new stable point is reached. By this time, the momentum carries the rotor past the stable position and the torque now reverses, slowing the rotor down and bringing it back in the opposite direction. The amplitude, frequency and decay rate of this oscillation will depend on the friction and inertia in the system as well as the electrical characteristics of the motor and drive. The initial overshoot also depends on step amplitude, so half-stepping produces less overshoot than full stepping and microstepping will be better still.

Fig. 1.19 Single step response

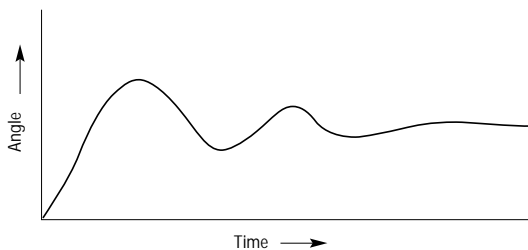

Attempting to step the motor at its natural oscillation frequency can cause an exaggerated response known as resonance. In severe cases, this can lead to the motor desynchronizing or "stalling." It is seldom a problem with half-step drives and even less so with a microstepper. The natural resonant speed is typically 100-200 full steps/sec. (0.5-1 rev/sec).

Under full dynamic conditions, the performance of the motor is described by the torque-speed curve as shown in Fig. 1.20. There are two operating ranges, the start/stop (or pull in) range and the slew (or pull out) range. Within the start/stop range, the motor can be started or stopped by applying index pulses at constant frequency to the drive. At speeds within this range, the motor has sufficient torque to accelerate its own inertia up to synchronous speed without the position lag exceeding 3.6° . Clearly, if an inertial load is added, this speed range is reduced. So the start/stop speed range depends on the load inertia. The upper limit to the start/stop range is typically between 200 and 500 full steps/sec (1-2.5 revs/sec).

Fig. 1.20 Start/stop and slew curves

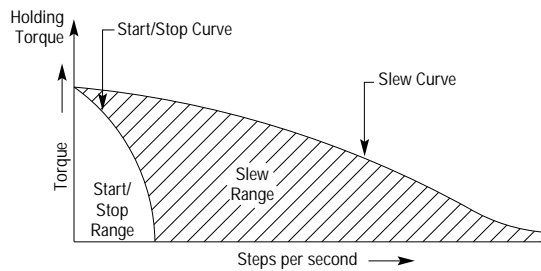

To operate the motor at faster speeds, it is necessary to start at a speed within the start/stop range and then accelerate the motor into the slew region. Similarly, when stopping the motor, it must be decelerated back into the start/stop range before the clock pulses are terminated. Using acceleration and deceleration "ramping" allows much higher speeds to be achieved, and in industrial applications the useful speed range extends to about 3000 rpm (10,000 full steps/sec). Note that continuous operation at high speeds is not normally possible with a stepper due to rotor heating, but high speeds can be used successfully in positioning applications.

The torque available in the slew range does not depend on load inertia. The torque-speed curve is normally measured by accelerating the motor up to speed and then increasing the load until the motor stalls. With a higher load inertia, a lower acceleration rate must be used but the available torque at the final speed is unaffected.

Common Questions and Answers About Step Motors

- Why do step motors run hot?*
Two reasons: 1. Full current flows through the motor windings at standstill. 2. PWM drive designs tend to make the motor run hotter. Motor construction, such as lamination material and riveted rotors, will also affect heating.
- What are safe operating temperatures?*
The motors have class B insulation, which is rated at 130°C. Motor case temperatures of 90°C will not cause thermal breakdowns. Motors should be mounted where operators cannot come into contact with the motor case.
- What can be done to reduce motor heating?*
Many drives feature a "reduce current at standstill" command or jumper. This reduces current when the motor is at rest without positional loss.
- What does the absolute accuracy specification mean?*
This refers to inaccuracies, non-cumulative, encountered in machining the motor.
- How can the repeatability specification be better than that of accuracy?*
Repeatability indicates how precisely a previous position can be re-obtained. There are no inaccuracies in the system that affect a given position, returning to that position, the same inaccuracy is encountered.
- Will motor accuracy increase proportionately with the resolution?*
No. The basic absolute accuracy and hysteresis of the motor remain unchanged.
- Can I use a small motor on a large load if the torque requirement is low?*
Yes, however, if the load inertia is more than ten times the rotor inertia, cogging and extended ringing at the end of the move will be experienced.
- How can end of move "ringing" be reduced?*
Friction in the system will help damp this oscillation. Acceleration/deceleration rates could be increased. If start/stop velocities are used, lowering or eliminating them will help.
- Why does the motor stall during no load testing?*
The motor needs inertia roughly equal to its own inertia to accelerate properly. Any resonances developed in the motor are at their worst in a no-load condition.
- Why is motor sizing important, why not just go with a larger motor?*
If the motor's rotor inertia is the majority of the load, any resonances may become more pronounced. Also, productivity would suffer as excessive time would be required to accelerate the larger rotor inertia. Smaller may be better.
- What are the options for eliminating resonance?*
This would most likely happen with full step systems. Adding inertia would lower the resonant frequency. Friction would tend to dampen the modulation. Start/stop velocities higher than the resonant point could be used. Changing to half step operation would greatly help. Ministepping and microstepping also greatly minimize any resonant vibrations. Viscous inertial dampers may also help.
- Why does the motor jump at times when it's turned on?*
This is due to the rotor having 200 natural detent positions. Movement can then be $\pm 3.6^\circ$ in either direction.
- Do the rotor and stator teeth actually mesh?*
No. While some designs used this type of harmonic drive, in this case, an air gap is very carefully maintained between the rotor and the stator.
- Does the motor itself change if a microstepping drive is used?*
The motor is still the standard 1.8° stepper. Microstepping is accomplished by proportioning currents in the drive (higher resolutions result). Ensure the motor's inductance is compatible.
- A move is made in one direction, and then the motor is commanded to move the same distance but in the opposite direction. The move ends up short, why?*
Two factors could be influencing the results. First, the motor does have magnetic hysteresis that is seen on direction changes. This is in the area of 0.03°. Second, any mechanical backlash in the system to which the motor is coupled could also cause loss of motion.
- Why are some motors constructed as eight-lead motors?*
This allows greater flexibility. The motor can be run as a six-lead motor with unipolar drives. With bipolar drives, the windings can then be connected in either series or parallel.
- What advantage do series or parallel connection windings give?*
With the windings connected in series, low-speed torques are maximized. But this also gives the most inductance so performance at higher speeds is lower than if the windings were connected in parallel.
- Can a flat be machined on the motor shaft?*
Yes, but care must be taken to not damage the bearings. The motor must not be disassembled. Compumotor does not warranty the user's work.
- How long can the motor leads be?*
For bipolar drives, 100 feet. For unipolar designs, 50 feet. Shielded, twisted pair cables are required.
- Can specialty motors, explosion-proof, radiation-proof, high-temperature, low-temperature, vacuum-rated, or waterproof, be provided?*
Compumotor is willing to quote on most requirements with the exception of explosion proof.
- What are the options if an explosion-proof motor is needed?*
Installing the motor in a purged box should be investigated.

DC Brush Motors

The history of the DC motor can be traced back to the 1830s, when Michael Faraday did extensive work with disc type machines (Fig. 1.21).

Fig. 1.21 Simple disc motor

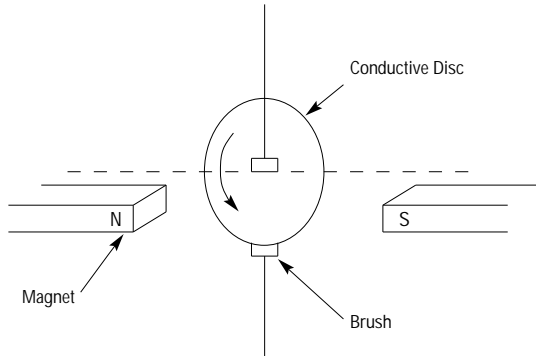

This design was quickly improved, and by the end of the 19th century the design principles of DC motors had become well established.

About that time; however, AC power supply systems came into general use and the popularity of the DC motor declined in favor of the less expensive AC induction motor. More recently, the particular characteristics of DC motors, notably high starting torque and controllability, have led to their application in a wide range of systems requiring accurate control of speed and position. This process has been helped by the development of sophisticated modern drive and computer control systems.

Principles

It is well known that when a current-carrying conductor is placed in a magnetic field, it experiences a force (Fig. 1.22).

Fig. 1.22 Force on a conductor in a magnetic field

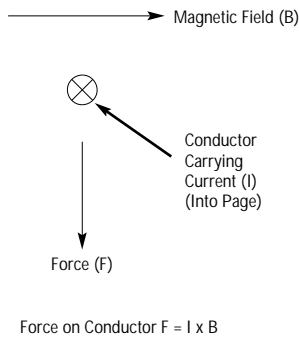

The force acting on the conductor is given by:

$$F = I \times B$$

where B = magnetic flux density and I = current

If this single conductor is replaced by a large number of conductors (i.e., a length of wire is wound into a coil), the force per unit length is increased by the number of turns in the coil. This is the basis of a DC motor.

Practical Considerations

The problem now is that of using this force to produce the continuous torque required in a practical motor.

To achieve maximum performance from the motor, the maximum number of conductors must be placed in the magnetic field, to obtain the greatest possible force. In practice, this produces a cylinder of wire, with the windings running parallel to the axis of the cylinder. A shaft is placed down this axis to act as a pivot, and this arrangement is called the motor armature (Fig. 1.23).

Fig. 1.23 DC motor armature

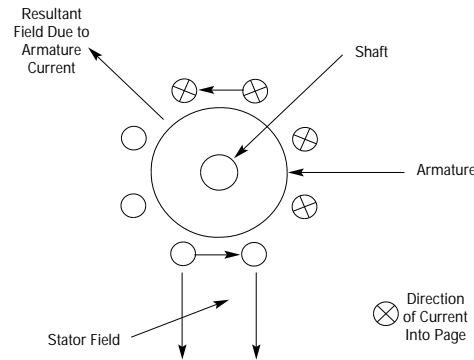

As the armature rotates, so does the resultant magnetic field. The armature will come to rest with its resultant field aligned with that of the stator field, unless some provision is made to constantly change the direction of the current in the individual armature coils.

Commutation

The force that rotates the motor armature is the result of the interaction between two magnetic fields (the stator field and the armature field). To produce a constant torque from the motor, these two fields must remain constant in magnitude and in relative orientation.

Fig. 1.24 Electrical arrangement of the armature

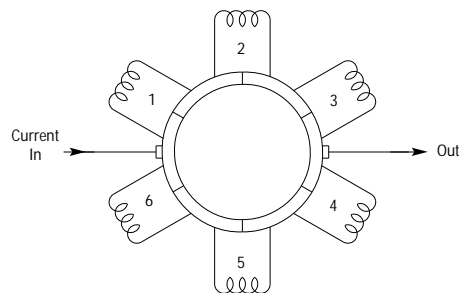

This is achieved by constructing the armature as a series of small sections connected in sequence to the segments of a commutator (Fig 1.24). Electrical connection is made to the commutator by means of two brushes. It can be seen that if the armature rotates through 1/6 of a revolution clockwise, the current in coils 3 and 6 will have changed direction. As successive commutator segments pass the brushes, the current in the coils connected to those segments changes direction. This commutation or switching effect results in a current flow in the

armature that occupies a fixed position in space, independent of the armature rotation, and allows the armature to be regarded as a wound core with an axis of magnetization fixed in space. This gives rise to the production of a constant torque output from the motor shaft.

The axis of magnetization is determined by the position of the brushes. If the motor is to have similar characteristics in both directions of rotation, the brush axis must be positioned to produce an axis of magnetization that is at 90° to the stator field.

DC Motor Types

Several different types of DC motor are currently in use.

Iron cored. (Fig. 1.25). This is the most common type of motor used in DC servo systems. It is made up of two main parts; a housing containing the field magnets and a rotor made up of coils of wire wound in slots in an iron core and connected to a commutator. Brushes, in contact with the commutator, carry current to the coils.

Fig. 1.25 Iron-cored motor

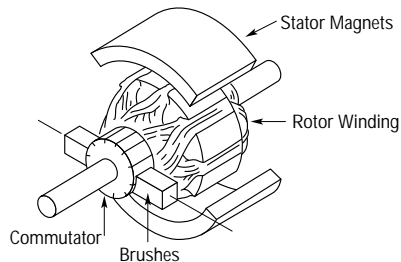

Moving coil. There are two principle forms of this type of motor. 1. The "printed" motor (Fig. 1.26), using a disc armature. 2. The "shell" type armature (Fig. 1.27).

Since these types of motors have no moving iron in their magnetic field, they do not suffer from iron losses. Consequently, higher rotational speeds can be obtained with low power inputs.

Fig. 1.26 Disc-armature "printed" motor

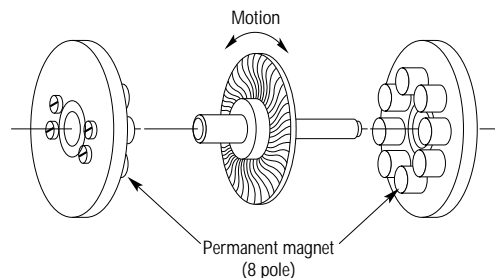
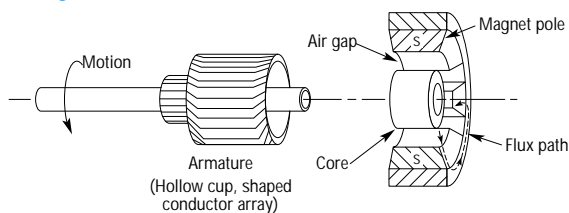

Fig. 1.27 Shell-armature motor



Diagrams courtesy of Electro-Craft Ltd.

Brushless. The major limiting factor in the performance of iron-cored motors is internal heating. This heat escapes through the shaft and bearings to the outer casing, or through the air gap between the armature and field magnets and from there to the casing. Both of these routes are thermally inefficient, so cooling of the motor armature is very poor.

Fig. 1.28 Brushless motor

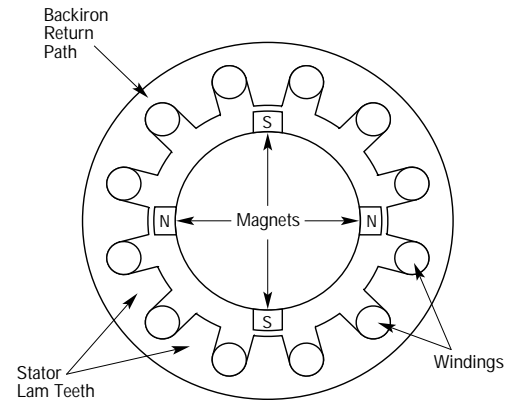

In the brushless motor, the construction of the iron cored motor is turned inside out, so that the rotor becomes a permanent magnet and the stator becomes a wound iron core.

The current-carrying coils are now located in the housing, providing a short, efficient thermal path to the outside air. Cooling can further be improved by finning the outer casing and blowing air over it if necessary (to effectively cool an iron-cored motor, it is necessary to blow air through it.) The ease of cooling the brushless motor allows it to produce a much higher power in relation to its size.

The other major advantage of brushless motors is their lack of a conventional commutator and brush gear. These items are a source of wear and potential trouble and may require frequent maintenance. By not having these components, the brushless motor is inherently more reliable and can be used in adverse environmental conditions.

To achieve high torque and low inertia, brushless motors do require rare earth magnets that are much more expensive than conventional ceramic magnets. The electronics necessary to drive a brushless motor are also more complex than for a brush motor. A more thorough explanation of brushless motors is provided on page A17.

Losses in DC Motors

DC motors are designed to convert electrical power into mechanical power and as a consequence of this, during periods of deceleration or if externally driven, will generate electrical power. However, all the input power is not converted into mechanical power due to the electrical resistance of the armature and other rotational losses. These losses give rise to heat generation within the motor.

Motor losses can be divided into two areas: Those that depend on the load and those that depend on speed (Fig. 1.29).

Fig. 1.29 Losses in a DC motor

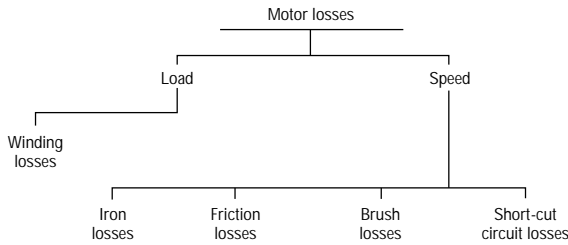

Winding losses. These are caused by the electrical resistance of the motor windings and are equal to I^2R (where I = armature current and R = armature resistance).

As the torque output of the motor increases, I increases, which gives rise to additional losses. Consideration of winding losses is very important since heating of the armature winding causes an increase in R , which results in further losses and heating. This process can destroy the motor if the maximum current is not limited. Furthermore, at higher temperatures, the field magnets begin to lose their strength. Hence, for a required torque output the current requirement becomes greater.

Brush contact losses. These are fairly complex to analyze since they depend upon several factors that will vary with motor operation. In general, brush contact resistance may represent a high proportion of the terminal resistance of the motor. The result of this resistance will be increased heating due to I^2R losses in the brushes and contact area.

Iron losses. Iron losses are the major factor in determining the maximum speed that may be attained by an iron-cored motor. These fall into two categories:

- Eddy current losses are common in all conductive cored components experiencing a changing magnetic field. Eddy currents are induced into the motor armature as it undergoes changes in magnetization. These currents are speed-dependent and have a significant heating effect at high speeds. In practice, eddy currents are reduced by producing the armature core as a series of thin, insulated sections or laminations, stacked to produce the required core length.
- Hysteresis losses are caused by the resistance of the core material to constant changes of magnetic orientation, giving rise to additional heat generation, which increases with speed.

Friction losses. These are associated with the mechanical characteristics of the motor and arise from brush friction, bearing friction, and air resistance. These variables will generate heat and will require additional armature current to offset this condition.

Short circuit currents. As the brushes slide over the commutator, the brush is in contact with two commutator segments for a brief period. During this period, the brush will short out the coil connected to those segments (Fig. 1.30). This condition generates a torque that opposes the main driving torque and increases with motor speed.

Fig. 1.30 Generation of short-circuit currents

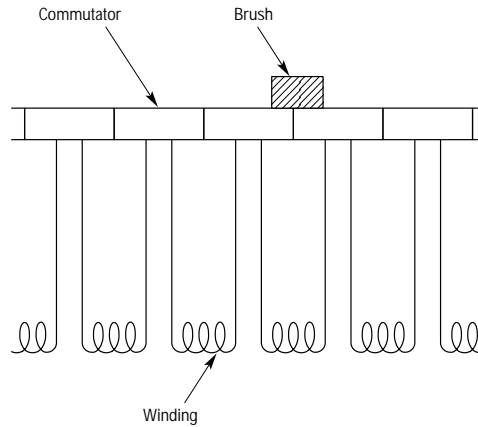

All these losses will contribute heat to the motor and it is this heating that will ultimately limit the motor application.

Other Limiting Considerations

Torque ripple. The requirement for constant torque output from a DC motor is that the magnetic fields due to the stator and the armature are constant in magnitude and relative orientation, but this ideal is not achieved in practice. As the armature rotates, the relative orientation of the fields will change slightly and this will result in small changes in torque output called "torque ripple" (Fig. 1.31).

Fig. 1.31 Torque ripple components

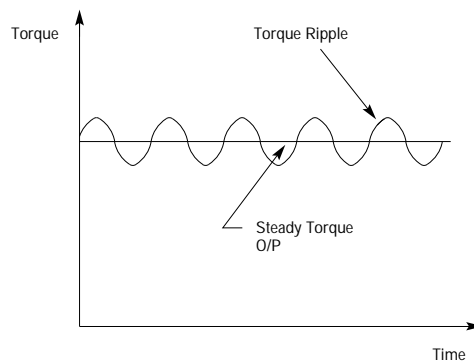

This will not usually cause problems at high speeds since the inertia of the motor and the load will tend to smooth out the effects, but problems may arise at low speeds.

Motors can be designed to minimize the effects of torque ripple by increasing the number of windings, or the number of motor poles, or by skewing the armature windings.

Demagnetization. The permanent magnets of a DC motor field will tend to become demagnetized whenever a current flows in the motor armature. This effect is known as “armature reaction” and will have a negligible effect in normal use. Under high load conditions, however, when motor current may be high, the effect will cause a reduction in the torque constant of the motor and a consequent reduction in torque output.

Above a certain level of armature current, the field magnets will become permanently demagnetized. Therefore, it is important not to exceed the maximum pulse current rating for the motor.

Mechanical resonances and backlash. It might normally be assumed that a motor and its load, including a tachometer or position encoder, are all rigidly connected together. This may, however, not be the case.

It is important for a bi-directional drive or positioning system that the mechanics are free from backlash, otherwise, true positioning will present problems.

In high-performance systems, with high accelerations, interconnecting shafts and couplings may deflect under the applied torque, such that the various parts of the system may have different instantaneous velocities that may be in opposite directions. Under certain conditions, a shaft may go into *torsional resonance* (Fig. 1.32).

Fig. 1.32 Torsional oscillation

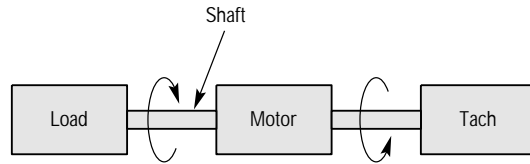

Back emf

As described previously, a permanent magnet DC motor will operate as a generator. As the shaft is rotated, a voltage will appear across the brush terminals. This voltage is called the *back electromotive force* (emf) and is generated even when the motor is driven by an applied voltage. The output voltage is essentially linear with motor speed and has a slope that is defined as the motor voltage constant, K_E (Fig. 1.33). K_E is typically quoted in volts per 1000 rpm.

Fig. 1.33 Back-emf characteristic

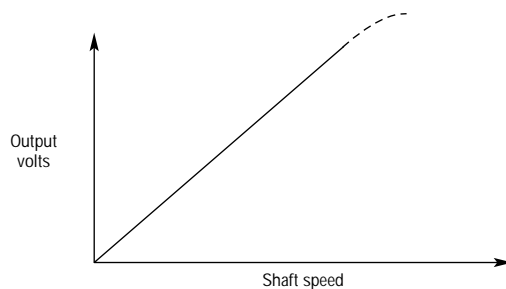

Motor Equations

Unlike a step motor, the DC brush motor exhibits simple relationships between current, voltage, torque and speed. It is therefore worth examining these relationships as an aid to the application of brush motors.

The application of a constant voltage to the terminals of a motor will result in its accelerating to attain a steady final speed (n). Under these conditions, the voltage (V) applied to the motor is opposed by the back emf (nK_E) and the resultant voltage drives the motor current (I) through the motor armature and brush resistance (R_s).

The equivalent circuit of a DC motor is shown in Fig. 1.34.

Fig. 1.34 DC motor equivalent circuit

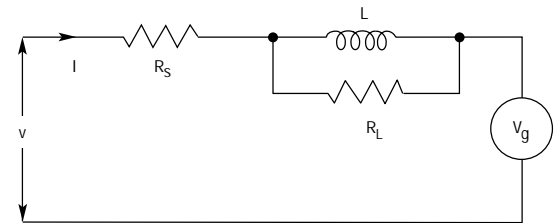

R_s = motor resistance

L = winding inductance

V_g = back emf and

R_L represents magnetic losses.

The value of R_L is usually large and so can be ignored, as can the inductance L , which is generally small.

If we apply a voltage (V) to the motor and a current (I) flows, then:

$$V = IR_s + V_g$$

but $V_g = nK_E$

$$\text{so } V = IR_s + nK_E \quad (1)$$

This is the electrical equation of the motor.

If K_T is the torque constant of the motor (typically in oz/in per Amp), then the torque generated by the motor is given by:

$$T = IK_T \quad (2)$$

The opposing torque due to friction (T_f) and viscous damping (K_D) is given by:

$$T_M = T_f + nK_D$$

If the motor is coupled to a load T_L , then at constant speed:

$$T = T_L + T_f + nK_D \quad (3)$$

Equations (1), (2) and (3) allow us to calculate the required current and drive voltage to meet given torque and speed requirements. The values of K_T , K_E , etc. are given in the motor manufacturer's data.

Brushless Motors

Before we talk about brushless motors in detail, let's clear up a few points about terminology. The term "brushless" has become accepted as referring to a particular variety of servo motor. Clearly a step motor is a brushless device, as is an AC induction motor (in fact, the step motor can form the basis of a brushless servo motor, often called a hybrid servo, which is discussed later). However, the so-called "brushless" motor has been designed to have a similar performance to the DC brush servo without the limitations imposed by a mechanical commutator.

Within the brushless category are two basic motor types: trapezoidal and sine wave motors. The trapezoidal motor is really a brushless DC servo, whereas the sine wave motor bears a close resemblance to the AC synchronous motor. To fully explain the difference between these motors, we must review the evolution of the brushless motor.

Fig. 1.35 Conventional DC brush motor

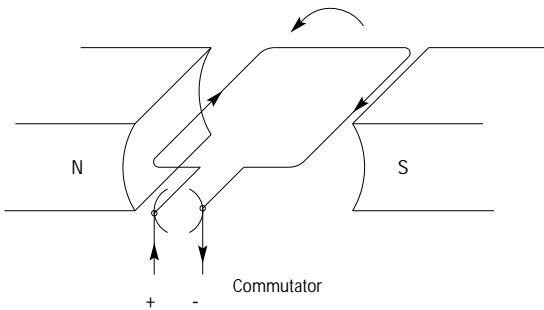

A simple conventional DC brush motor (Fig. 1.35) consists of a wound rotor that can turn within a magnetic field provided by the stator. If the coil connections were made through slip rings, this motor would behave like a step motor (reversing the current in the rotor would cause it to flip through 180°). By including the commutator and brushes, the reversal of current is made automatically and the rotor continues to turn in the same direction.

Fig. 1.36 "Inside out" DC motor

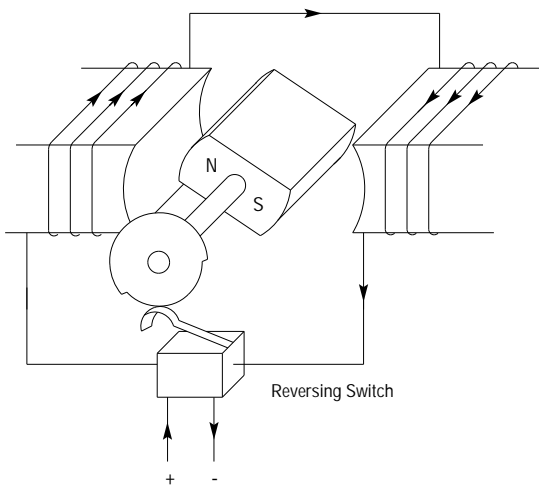

Brushless Motor Operation

To turn this motor into a brushless design, we must start by eliminating the windings on the rotor. This can be achieved by turning the motor inside out. In other words, we make the permanent magnet the rotating part and put the windings on the stator poles. We still need some means of reversing the current automatically – a cam-operated reversing switch could be made to do this job (Fig. 1.36). Obviously such an arrangement with a mechanical switch is not very satisfactory, but the switching capability of non-contacting devices tends to be very limited. However, in a servo application, we will use an electronic amplifier or drive which can also be used to do the commutation in response to low-level signals from an optical or hall-effect sensor (see Fig. 1.37). This component is referred to as the commutation encoder. So unlike the DC brush motor, the brushless version cannot be driven by simply connecting it to a source of direct current. The current in the external circuit must be reversed at defined rotor positions. Hence, the motor is actually being driven by an alternating current.

Fig. 1.37 Brushless motor

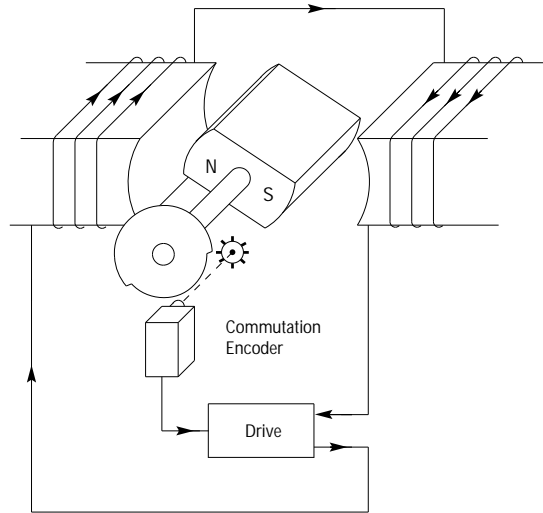

Going back to the conventional brush motor, a rotor consisting of only one coil will exhibit a large torque variation as it rotates. In fact, the characteristic will be sinusoidal, with maximum torque produced when the rotor field is at right angles to the stator field and zero torque at the commutation point (see Fig. 1.38). A practical DC motor has a large number of coils on the rotor, each one connected not only to its own pair of commutator segments but to the other coils as well. In this way, the chief contribution to torque is made by a coil operating close to its peak-torque position. There is also an averaging effect produced by current flowing in all the other coils, so the resulting torque ripple is very small.

Fig. 1.38 3-phase brushless motor

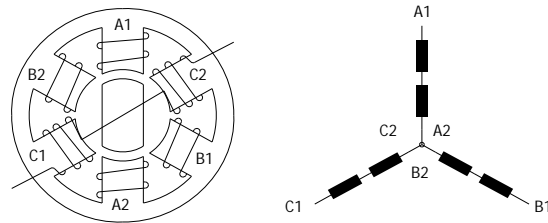

We would like to reproduce a similar situation in the brushless motor; however, this would require a large number of coils distributed around the stator. This may be feasible, but each coil would require its own individual drive circuit. This is clearly prohibitive, so a compromise is made. A typical brushless motor has either two or three sets of coils or "phases" (see Fig. 1.38). The motor shown in Fig. 1.38 is a two-pole, three-phase design. The rotor usually has four or six rotor poles, with a corresponding increase in the number of stator poles. This doesn't increase the number of phases—each phase has its turns distributed between several stator poles.

Fig. 1.39 Position-torque characteristic

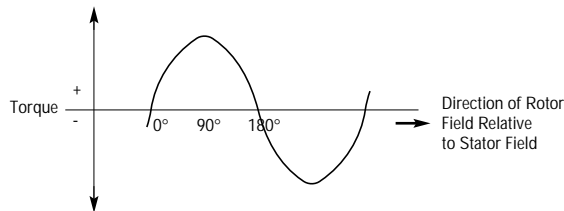
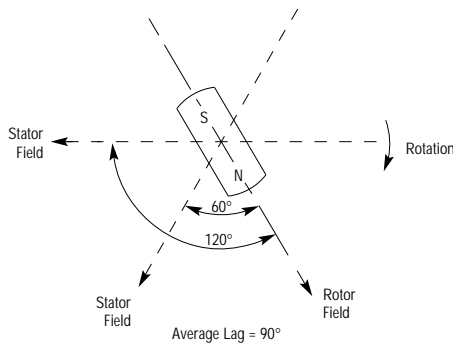
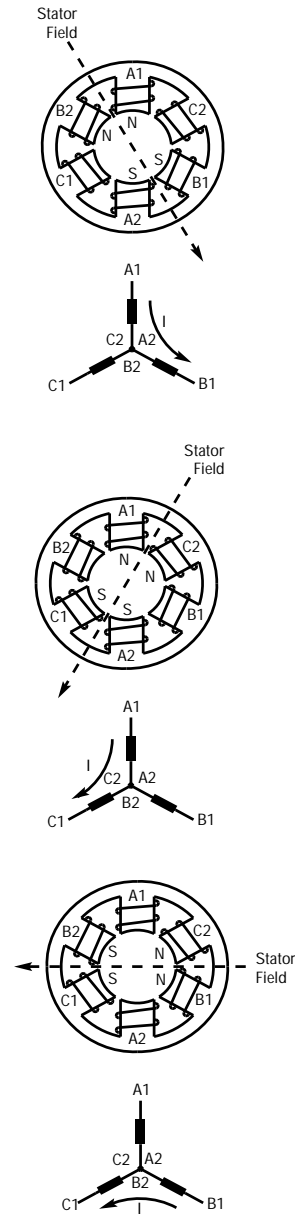

Fig. 1.40 Stator field positions for different phase currents



The torque characteristic in Fig. 1.39 indicates that maximum torque is produced when the rotor and stator fields are at 90° to each other. Therefore, to generate constant torque we would need to keep the stator field a constant 90° ahead of the rotor. Limiting the number of phases to three means that we can only advance the stator field in increments of 60° (Fig. 1.40). This means we must keep the stator field in the same place during 60° of shaft rotation. So we can't maintain a constant 90° torque angle, but we can maintain an average of 90° by working between 60° and 120° . Fig. 1.41 shows the rotor position at a commutation point. When the torque angle has fallen to 60° , the stator field is advanced from 1 to 2 so that the angle now increases to 120° , and it stays here during the next 60° of rotation.

Fig. 1.41 Position of rotor at commutation point



The Trapezoidal Motor

With a fixed current level in the windings, the use of this extended portion of the sinusoidal torque characteristic gives rise to a large degree of torque ripple. We can minimize the effect by manipulating the motor design to “flatten out” the characteristic – to make it trapezoidal, (Fig. 1.42). In practice, this is not very easy to do, so some degree of non-linearity will remain. The effect of this tends to be a slight “kick” at the commutation points, which can be noticeable when the motor is running very slowly.

Fig. 1.42 Trapezoidal motor characteristic

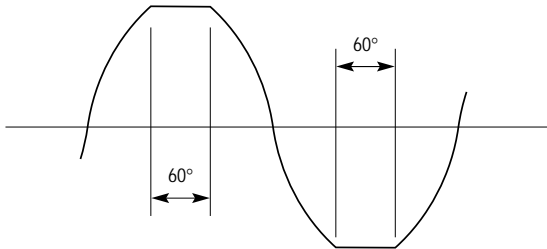

Torque ripple resulting from non-linearity in the torque characteristic tends to produce a velocity modulation in the load. However, in a system using velocity feedback the velocity loop will generally have a high gain. This means that a very small increase in velocity will generate a large error signal, reducing the torque demand to correct the velocity change. So in practice, the output current from the amplifier tends to mirror the torque characteristic (Fig. 1.43) so that the resulting velocity modulation is extremely small.

Fig. 1.43 Current profile in velocity-controlled servo

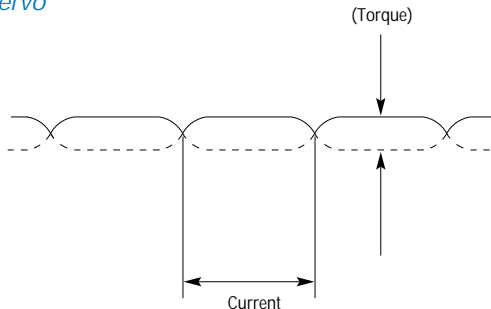

The Sine Wave Motor

In the sine wave motor (sometimes called an AC brushless servo), no attempt is made to modify the basic sinusoidal torque characteristic. Such a motor can be driven like an AC synchronous motor by applying sinusoidal currents to the motor windings. These currents must have the appropriate phase displacement, 120° in the case of the three-phase motor. We now need a much higher resolution device to control the commutation if we want smooth rotation at low speeds. The drive needs to generate 3 currents that are in the correct relationship to each other at every rotor position. So rather than the simple commutation encoder generating a handful of switching points, we now need a resolver or high-resolution optical encoder. In this way, it’s possible to maintain a 90° torque

angle very accurately, resulting in very smooth low-speed rotation and negligible torque ripple. A simplified explanation of why the sine wave motor produces constant torque is given in the next section.

The drive for a sine wave motor is more complex than for the trapezoidal version. We need a reference table from which to generate the sinusoidal currents, and these must be multiplied by the torque demand signal to determine their absolute amplitude. With a star-connected three-phase motor, it is sufficient to determine the currents in two of the windings—this will automatically determine what happens in the third. As previously mentioned, the sine wave motor needs a high-resolution feedback device. However, this device can also provide position and velocity information for the controller.

Why constant torque from a sine wave motor?

To understand this, it’s easier to think in terms of a two-phase motor. This has just two sets of windings that are fed with sinusoidal currents at 90° to each other. If we represent shaft position by an angle θ , then the currents in the two windings are of the form $I \sin\theta$ and $I \cos\theta$.

Going back to our original motor model, you’ll remember that the fundamental torque characteristic of the motor is also sinusoidal. So for a given current I , the instantaneous torque value looks like:

$$T = I K_T \sin\theta$$

Where K_T is the motor torque constant

By making the motor current sinusoidal as well, and in phase with the motor torque characteristic, the torque generated by one phase becomes:

$$T_1 = (I \sin\theta) K_T \sin\theta = I K_T \sin^2\theta$$

Similarly, the torque produced by the other phase is:

$$T_2 = I K_T \cos^2\theta$$

The total torque is:

$$T_1 + T_2 = I K_T (\sin^2\theta + \cos^2\theta)$$

but: $\sin^2\theta + \cos^2\theta = 1$ for any value of θ

therefore: $T_1 + T_2 = I K_T$

So for sinusoidal phase currents with a constant amplitude, the resultant torque is also constant and independent of shaft position.

For this condition to remain true, the drive currents must accurately follow a sine-cosine relationship. This can only occur with a sufficiently high resolution in the encoder or resolver used for commutation.

The Hybrid Servo

In terms of their basic operation, the step motor and the brushless servo motor are identical. They each have a rotating magnet system and a wound stator. The only difference is that one has more poles than the other, typically two or three pole-pairs in the brushless servo and 50 in the stepper. You could use a brushless servo as a stepper – not a very good one, since the step angle would be large. But by the same token, you can also use a stepper as a brushless servo by fitting a feedback device to perform the commutation. Hence the “hybrid servo”, so called because it is based on a hybrid step motor (Fig. 1.44). These have also been dubbed ‘stepping servos’ and ‘closed-loop steppers’. We prefer not to use the term ‘stepper’ at all since such a servo exhibits none of the operating characteristics of a step motor.

The hybrid servo is driven in precisely the same fashion as the brushless motor. A two-phase drive provides sine and cosine current waveforms in response to signals from the feedback device. This device may be an optical encoder or a resolver. Since the motor has 50 pole pairs, there will be 50 electrical cycles per revolution. This conveniently permits a 50-cycle resolver to be constructed from the same rotor and stator laminations as the motor itself.

A hybrid servo generates approximately the same torque output as the equivalent step motor, assuming the same drive current and supply voltage. However, the full torque capability of the motor can be utilized since the system is operating in a closed loop (with an open-loop step motor, it is always necessary to allow an adequate torque margin). The hybrid servo system will be more expensive than the equivalent step motor systems, but less costly than a brushless servo. As with the step motor, continuous operation at high speed is not recommended since the high pole count results in greater iron losses at high speeds. A hybrid servo also tends to run quieter and cooler than its step motor counterpart; since it is a true servo, power is only consumed when torque is required and normally no current will flow at standstill. Low-speed smoothness is vastly improved over the open-loop full step motor.

It is worth noting that the hybrid servo is entirely different from the open-loop step motor operated in ‘closed loop’ or ‘position tracking’ mode. In position tracking mode, an encoder measures the load movement and final positioning is determined by encoder feedback. While this technique can provide high positioning accuracy and eliminates undetected position loss, it does not allow full torque utilization, improve smoothness or reduce motor heating.

Fig. 1.44 Hybrid servo motor with resolver feedback

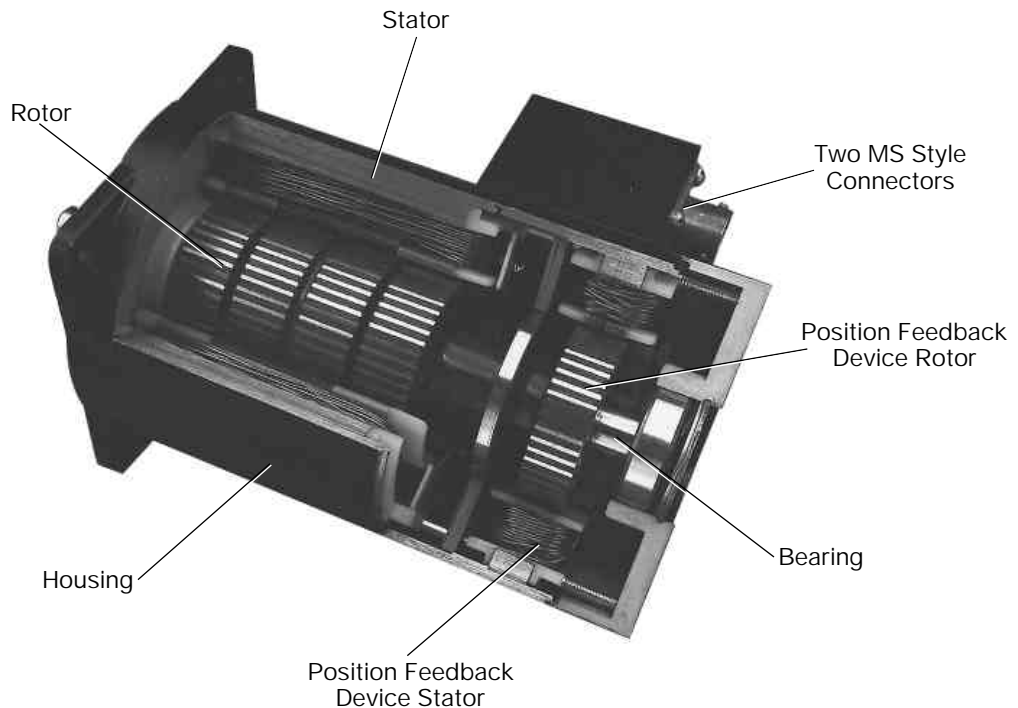

Direct Drive Motors

Motor Construction and Operation

Direct drive systems couple the system's load directly to the motor without the use of belts or gears. In some situations, brushed or brushless servo motors may lack adequate torque or resolution to satisfy some applications' needs. Therefore, mechanical means, such as gear reduction systems to increase torque and resolution, are used to meet system requirements. The Dynaserv Direct Drive can provide very high torque in a modest package size and solves many of the performance issues of the gear reducer. All in a system that is as easy to use as a stepping motor.

Fig. 1.45 below shows the construction of the Dynaserv DM Series direct drive motor compared to a conventional motor with a gear reducer. The gear reducer relies on large amounts of frictional contact to reduce the speed of the load. This gearing effectively increases torque and resolution but sacrifices speed and accuracy. The direct drive motor is brushless and gearless so it eliminates friction from its power transmission. Since the feedback element is coupled directly to the load, system accuracy and repeatability are greatly increased and backlash is eliminated.

Fig. 1.45 Construction comparison

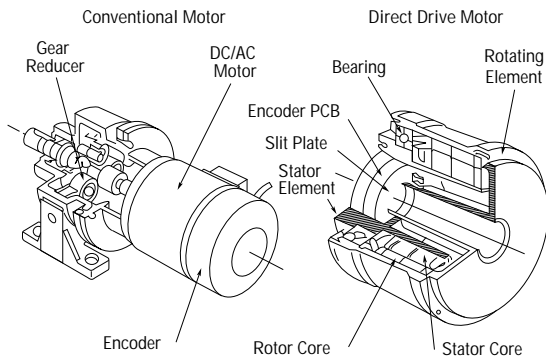

The motor contains precision bearings, magnetic components and integral feedback in a compact motor package (see Fig. 1.46). The motor is an outer rotor type, providing direct motion of the outside housing of the motor and thus the load. The cross roller bearings that support the rotor have high stiffness, to allow the motor to be connected directly to the load. In most cases, it is not necessary to use additional bearings or connecting shafts.

Fig. 1.46 Expanded motor view—
Dynaserv Model DM

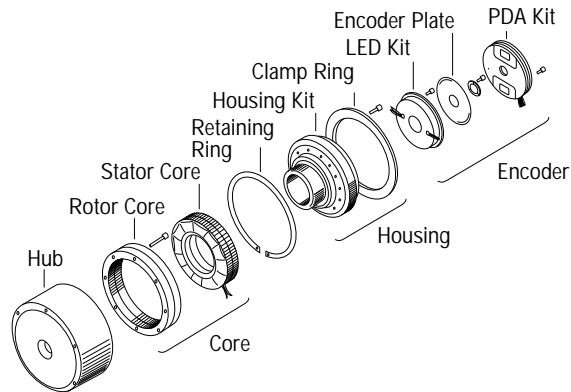

The torque is proportional to the square of the sum of the magnetic flux (Φ_m), of the permanent magnet rotor and the magnetic flux (Φ_s), of the stator windings. See Fig. 1.47. High torque is generated due to the following factors. First, the motor diameter is large. The tangential forces between rotor and stator act as a large radius, resulting in higher torque. Secondly, a large number of small rotor and stator teeth create many magnetic cycles per motor revolution. More working cycles means increased torque.

Fig. 1.47 Dynaserv magnetic circuit

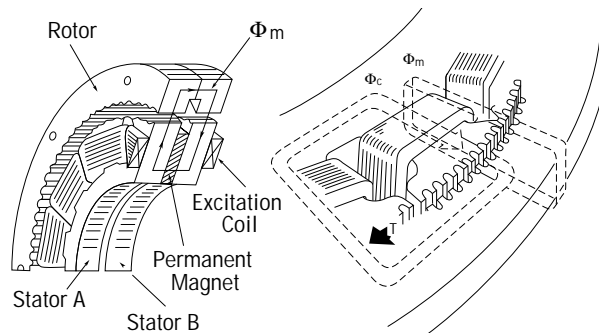

Direct Drive Motor Advantages

High Precision

Dynaserv motors eliminate the backlash or hysteresis inevitable in using any speed reducer. Absolute positioning of 30 arc-sec is typical with a repeatability of ± 2 arc-sec.

Faster Settling Time

The Dynaserv system reduces machine cycle times by decreasing settling times. This result is realized because of the "gearless" design and sophisticated "I-PD" control algorithm.

High Torque at High Speed

The torque/speed curve of the various Dynaserv models is very flat. This results in high acceleration at high speeds (4.0 rps) with good controllability.

Smooth Rotation

The very low velocity and torque ripple of the Dynaserv contribute to its excellent speed controllability with a more than 1:1,000 speed ratio.

Optimum Tuning

Dynaserv systems offer the user a tuning mode that simplifies the setting of optimum parameters for the actual load. Turning on the "test" switch on the front panel of the drive produces a test signal. Using an oscilloscope, the gain settings are quickly optimized by adjusting the digital switches and potentiometers on the front panel.

Clean Operation

The Dynaserv system is brushless and gearless, which results in a maintenance-free operation. With preparation, the Dynaserv can operate in class 10 environments.

Fig. 1.48 Dynaserv velocity/torque ripple

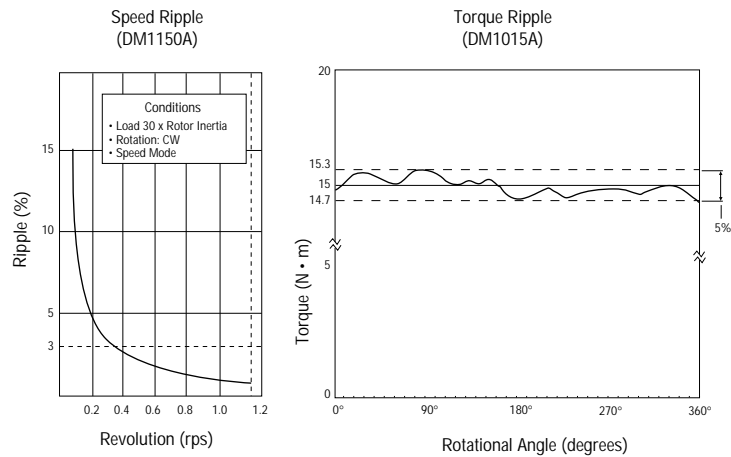

Stepping Motor Drives

The stepper drive delivers electrical power to the motor in response to low-level signals from the control system.

The motor is a torque-producing device, and this torque is generated by the interaction of magnetic fields. The driving force behind the stator field is the magneto-motive force (MMF), which is proportional to current and to the number of turns in the winding. This is often referred to as the amp-turns product. Essentially, the drive must act as a source of current. The applied voltage is only significant as a means of controlling the current.

Input signals to the stepper drive consist of step pulses and a direction signal. One step pulse is required for every step the motor is to take. This is true regardless of the stepping mode. So the drive may require 200 to 101,600 pulses to produce one revolution of the shaft. The most commonly-used stepping mode in industrial applications is the half-step mode in which the motor performs 400 steps per revolution. At a shaft speed of 1800 rpm, this corresponds to a step pulse frequency of 20kHz. The same shaft speed at 25,000 steps per rev requires a step frequency of 750 kHz, so motion controllers controlling microstep drives must be able to output a much higher step frequency.

Fig. 2.1 Stepper drive elements

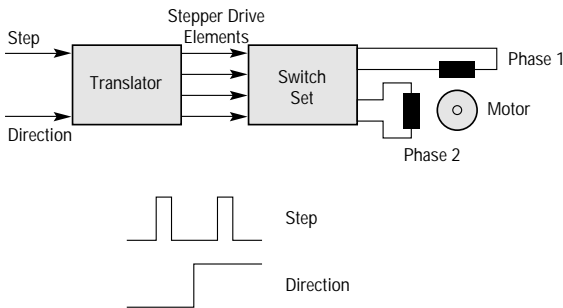

The logic section of the stepper drive is often referred to as the translator. Its function is to translate the step and direction signals into control waveforms for the switch set (see Fig. 2.1). The basic translator functions are common to most drive types, although the translator is necessarily more complex in the case of a microstepping drive. However, the design of the switch set is the prime factor in determining drive performance, so we will look at this in more detail.

The simplest type of switch set is the unipolar arrangement shown in Fig. 2.2. It is referred to as a unipolar drive because current can only flow in one direction through any particular motor terminal. A bifilar-wound motor must be used since reversal of the stator field is achieved by transferring current to the second coil. In the case of this very simple drive, the current is determined only by the motor winding resistance and the applied voltage.

Fig. 2.2 Basic unipolar drive

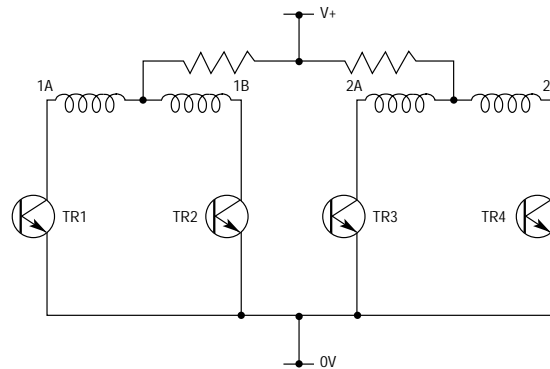

Such a drive will function perfectly well at low stepping rates, but as speed is increased, the torque will fall off rapidly due to the inductance of the windings.

Inductance/Water Analogy

For those not familiar with the property of inductance, the following water analogy may be useful (Fig. 2.3). An inductor behaves in the same way as a turbine connected to a flywheel. When the tap is turned on and pressure is applied to the inlet pipe, the turbine will take time to accelerate due to the inertia of the flywheel. The only way to increase

the acceleration rate is to increase the applied pressure. If there is no friction or leakage loss in the system, acceleration will continue indefinitely for as long as the pressure is applied. In a practical case, the final speed will be determined by the applied pressure and by friction and the leakage past the turbine blades.

Fig. 2.3 Inductance water analogy

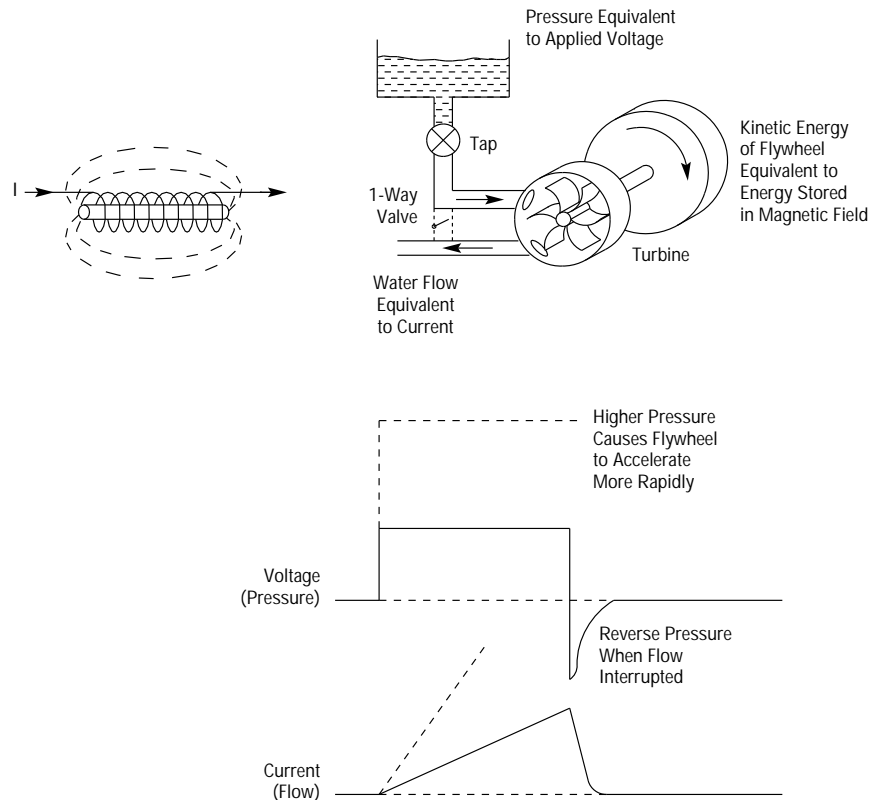

Applying a voltage to the terminals of an inductor produces a similar effect. With a pure inductance (i.e., no resistance), the current will rise in a linear fashion for as long as the voltage is applied. The rate of rise of current depends on the inductance and the applied voltage, so a higher voltage must be applied to get the current to rise more quickly. In a practical inductor possessing resistance, the final current is determined by the resistance and the applied voltage.

Once the turbine has been accelerated up to speed, stopping it again is not a simple matter. The kinetic energy of the flywheel has to be dissipated, and as soon as the tap is turned off, the flywheel drives the turbine like a pump and tries to keep the water flowing. This will set up a high pressure across the inlet and outlet pipes in the reverse direction. The equivalent energy store in the inductor is the magnetic field. As this field collapses, it tries to maintain the current flow by generating a high reverse voltage.

By including a one-way valve across the turbine connections, the water is allowed to continue circulating when the tap is turned off. The energy stored in the flywheel is now put to good use in maintaining the flow. We use the same idea in the recirculating chopper drive, in which a diode allows the current to recirculate after it has built up.

Going back to our simple unipolar drive, if we look at the way the current builds up (Fig. 2.4) we can see that it follows an exponential shape with its final value set by the voltage and the winding resistance. To get it to build up more rapidly, we could increase the applied voltage, but this would also increase the final current level. A simple way to alleviate this problem is to add a resistor in series with the motor to keep the current the same as before.

R-L Drive

The principle described in the Inductance/Water Analogy (p. A24) is applied in the resistance-limited (R-L) drive see Fig. 2.4. Using an applied voltage of 10 times the rated motor voltage, the current will reach its final value in one tenth of the time. If you like to think in terms of the electrical time constant, this has been reduced from L/R to $L/10R$, so we'll get a useful increase in speed. However we're paying a price for this extra performance. Under steady-state conditions, there is 9 times as much power dissipated in the series resistor as in the motor itself, producing a significant amount of heat. Furthermore, the extra power must all come from the DC power supply, so this must be much larger. R-L drives are therefore only suited to low-power applications, but they do offer the benefits of simplicity, robustness and low radiated interference.

Fig. 2.4 Principle of the R-L drive

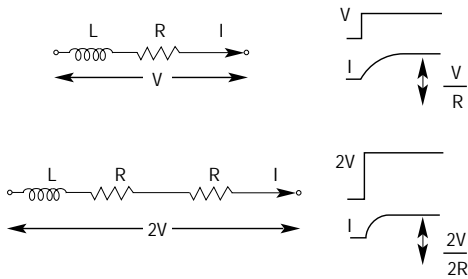

Unipolar Drive

Fig. 2.5 Basic unipolar drive

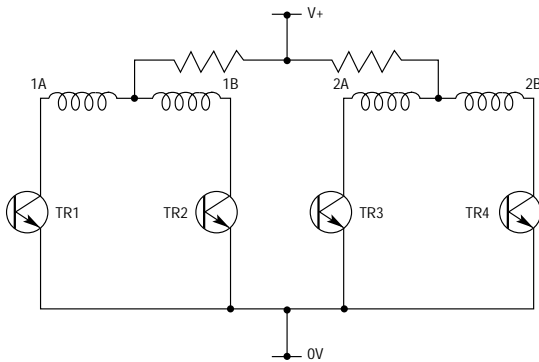

A drawback of the unipolar drive is its inability to utilize all the coils on the motor. At any one time, there will only be current flowing in one half of each winding. If we could utilize both sections at the same time, we could get a 40% increase in amp-turns for the same power dissipation in the motor.

To achieve high performance and high efficiency, we need a bipolar drive (one that can drive current in either direction through each motor coil) and a better method of current control. Let's look first at how we can make a bipolar drive.

Bipolar Drive

An obvious possibility is the simple circuit shown in Fig. 2.6, in which two power supplies are used together with a pair of switching transistors. Current can be made to flow in either direction through the motor coil by turning on one transistor or the other. However, there are distinct drawbacks to this scheme. First, we need two power supplies, both of which must be capable of delivering the total current for both motor phases. When all the current is coming from one supply the other is doing nothing at all, so the power supply utilization is poor. Second, the transistors must be rated at double the voltage that can be applied across the motor, requiring the use of costly components.

Fig. 2.6 Simple bipolar drive

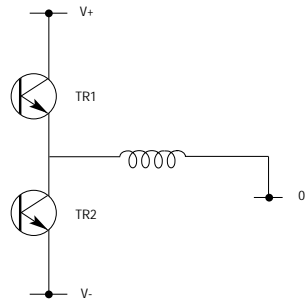

The standard arrangement used in bipolar motor drives is the bridge system shown in Fig. 2.7. Although this uses an extra pair of switching transistors, the problems associated with the previous configuration are overcome. Only one power supply is needed and this is fully utilized; transistor voltage ratings are the same as that available for driving the motor. In low-power systems, this arrangement can still be used with resistance limiting as shown in Fig. 2.8.

Fig. 2.7 Bipolar bridge

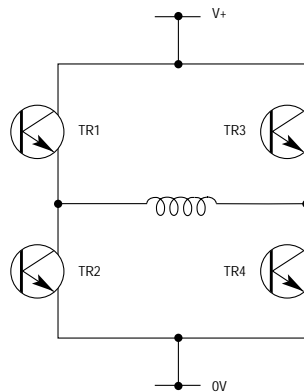
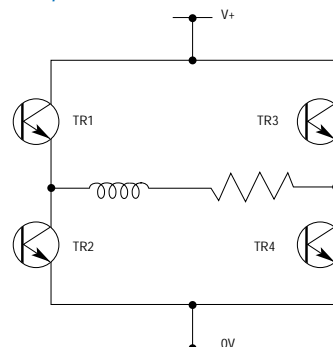

Fig. 2.8 Bipolar R-L drive



Recirculating Chopper Drive

The method of current control used in most stepper drives is the recirculating chopper (Fig. 2.9). This approach incorporates the four-transistor bridge, recirculation diodes, and a sense resistor. The resistor is of low value (typically 0.1 ohm) and provides a feedback voltage proportional to the current in the motor.

Fig. 2.9 Recirculating chopper drive

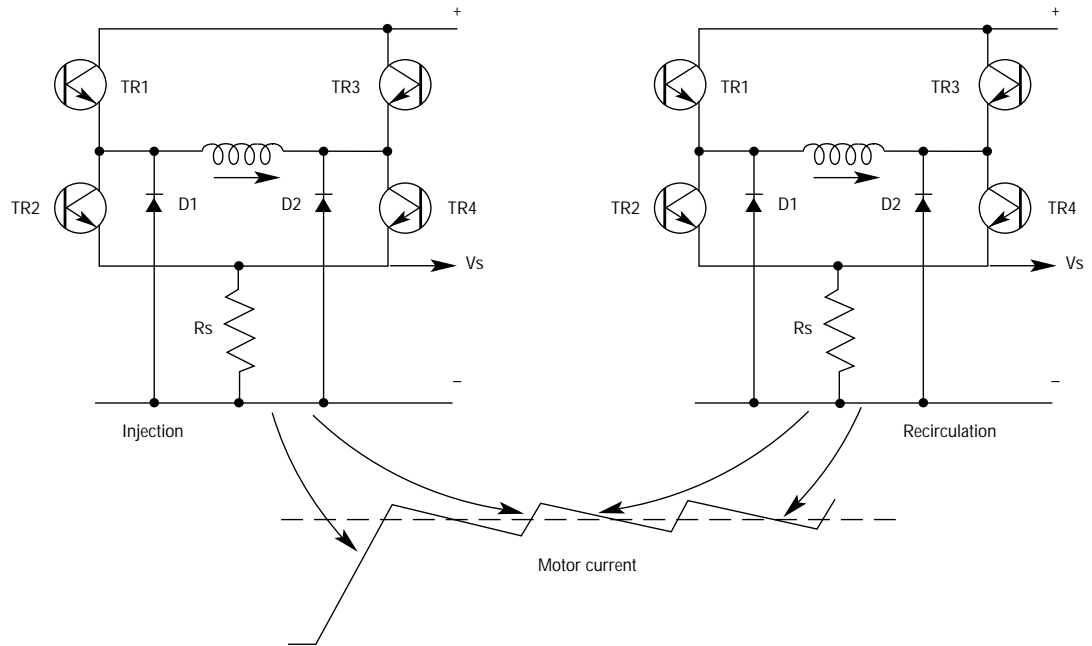

Current is injected into the winding by turning on one top switch and one bottom switch, and this applies the full supply voltage across the motor. Current will rise in an almost linear fashion and we can monitor this current by looking across the sense resistor. When the required current level has been reached, the top switch is turned off and the stored energy in the coil keeps the current circulating via the bottom switch and the diode. Losses in the system cause this current to slowly decay, and when a pre-set lower threshold is reached, the top switch is turned back on and the cycle repeats. The current is therefore maintained at the correct average value by switching or "chopping" the supply to the motor.

This method of current control is very efficient because very little power is dissipated in the switching transistors other than during the transient switching state. Power drawn from the power supply is closely related to the mechanical power delivered by the shaft (unlike the R-L drive, which draws maximum power from the supply at standstill).

A variant of this circuit is the regenerative chopper. In this drive, the supply voltage is applied across the motor winding in alternating directions, causing the current to ramp up and down at approximately equal rates. This technique tends to require fewer components and is consequently lower in cost, however, the associated ripple current in the motor is usually greater and increases motor heating.

Regeneration and Power Dumping

Like other rotating machines with permanent magnets, the step motor will act as a generator when the shaft is driven mechanically. This means that the energy imparted to the load inertia during acceleration is returned to the drive during deceleration. This will increase the motor current and can damage the power switches if the extra current is excessive. A threshold detector in the drive senses this increase in current and momentarily turns off all the bridge transistors (Fig. 2.10). There is now a path for the regenerated current back to the supply capacitor, where it increases the supply voltage. During this phase, the current is no longer flowing through the sense resistors, so the power switches must be turned on again after a short period (typically $30\mu\text{s}$) for conditions to be reassessed. If the current is still too high, the drive returns to the regenerative state.

Fig. 2.10 Current flow during regeneration

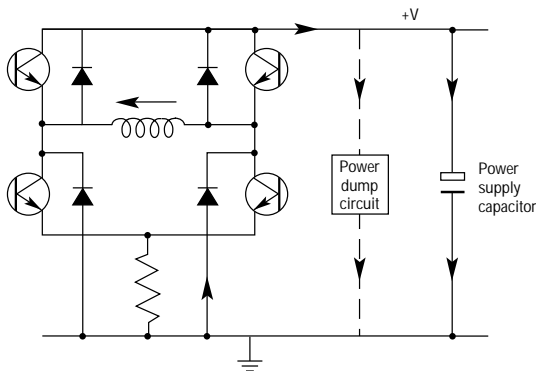

A small increase in supply voltage during regeneration is acceptable, but if the rise is too great the switches may be damaged by over-voltage rather than excessive current. To resolve this problem, we use a power dump circuit that dissipates the regenerated power.

The circuit of a simple power dump is shown in Fig. 2.11. A rectifier and capacitor fed with AC from the supply transformer provide a reference voltage equal to the peak value of the incoming AC. Under normal conditions this will be the same as the drive supply voltage. During excess regeneration, the drive supply voltage will rise above this reference, and this will turn on the dump transistor connecting the 33-ohm resistor across the power supply. When the supply voltage has decreased sufficiently, the transistor is turned back off. Although the instantaneous current flowing through the dump resistor may be relatively high, the average power dissipated is usually small since the dump period is very short. In applications where the regenerated power is high, perhaps caused by frequent and rapid deceleration of a high inertia, a supplementary high-power dump resistor may be necessary.

Fig. 2.11 Power dump circuit

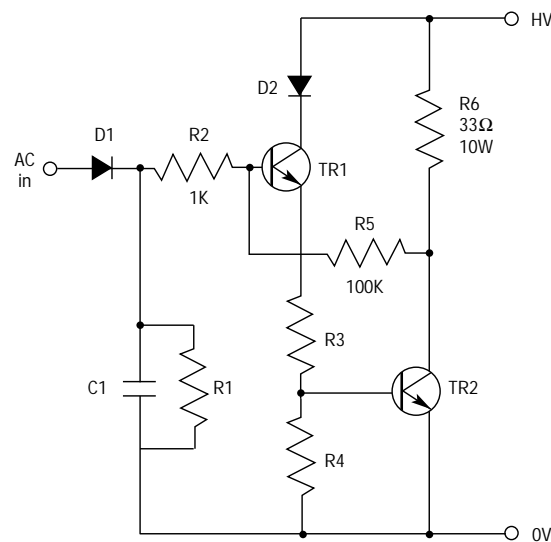

Stepper Drive Technology Overview

Within the various drive technologies, there is a spectrum of performance. The uni-polar resistance-limited (R-L) drive is a relatively simple design, but it lacks shaft power performance and is very inefficient. A uni-polar system only uses half of the motor winding at any instant. A bi-polar design allows torque producing current to flow in all motor windings, using the motor more efficiently, but increasing the complexity of the drive. A bi-polar R-L drive improves shaft performance, but is still very inefficient—generating a lot of wasted heat. An alternative to resistance-limiting is to control current by means of chopper regulation. A chopper regulator is very efficient since it does not waste power by dropping voltage through a resistor. However, good current control in the motor is essential to deliver optimum shaft power. Pulse width modulation (PWM) and threshold modulation are two types of chopper regulation techniques. PWM controls the average of the motor current and is very good for precise current control, while threshold modulation controls current to a peak level. Threshold modulation can be applied to a wider range of motors, but it does suffer greater loss of performance than PWM when the motor has a large resistance or long motor cables are used. Both chopper regulation techniques can use recirculating current control, which improves the power dissipation in the motor and drive and overall system efficiency. As system performance increases, the complexity and cost of the drive increases.

Stepper drive technology has evolved—being driven by machine builders that require more shaft power in smaller packages, higher speed capability, better efficiency, and improved accuracy. One trend of the technology is towards microstepping, a technique that divides each full step of the motor into smaller steps. This is achieved electronically in the drive by proportioning the current between the motor windings. The higher the resolution, the more precision is required in the current control circuits. In its simplest form, a half-step system increases the resolution of a standard 1.8° full-step motor to 400 steps/rev. Ministepping drives have more precise current control and can increase the resolution to 4,000 steps/rev. Microstep drives typically have resolutions of 50,000 steps/rev, and in addition to improved current control, they often have adjustments to balance offsets between each phase of the motor and to optimize the current profile for the particular motor being used.

Full-Step and Half-Step Systems

Full-step and half-step systems do not have the resolution capability of the ministepping or microstepping systems. However, the drive technology is not as complex and the drives are relatively inexpensive. Full-step and half-step systems will not have the same low-speed smoothness as higher resolution systems.

An inherent property of a stepper motor is its low-speed resonance, which may de-synchronize a motor and cause position loss. Full-step and half-step drives are more prone to resonance effects and this may limit their application in low-speed systems. Full-step and half-step systems can be operated at speeds above the motor's resonant speed without loss of synchronization. For this reason, full-step and half-step systems are normally applied in high-speed, point-to-point positioning applications. In these types of applications, the machine designer is primarily concerned with selecting a motor/drive system capable of producing the necessary power output.

Since power is the product of torque and speed, a high-torque system with low-speed capability may not produce as much power as a low-torque, high-speed system. Sizing the system for torque only may not provide the most cost-effective solution, selecting a system based on power output will make the most efficient use of the motor and drive.

Step motor systems typically require the motor to accelerate to reach high speed. If a motor was requested to run instantaneously at 3000 rpm, the motor would stall immediately. At slow speeds, it is possible to start the motor without position loss by applying unramped step pulses. The maximum speed at which synchronization will occur without ramping is called the *start/stop velocity*. The start/stop velocity is inversely proportional to the square-root of the total inertia. The start/stop capability provides a benefit for applications that require high-speed point-to-point positioning—since the acceleration to the start/stop velocity is almost instantaneous, the move-time will be reduced. No additional time is required to accelerate the motor from zero to the start/stop velocity. While the move-time can be reduced, it is generally more complicated for the controller or indexer to calculate the motion profile and implement a start/stop velocity. In most applications, using start/stop velocities will eliminate the need to run the motor at its resonant frequency and prevent de-synchronization.

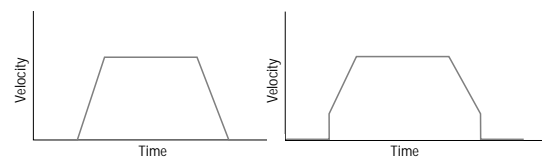

Ministep Systems

Applications that require better low-speed smoothness than a half-step system should consider using a microstepping or ministepping solution. Microstepping systems, with resolutions of 50,000 steps/rev, can offer exceptional smoothness, without requiring a gear-reducer. Ministepping systems typically do not have wave-trimming capability or offset adjustment to achieve the optimum smoothness, but offer a great improvement over full-step and half-step systems. Ministepping systems have resolutions between 1,000 and 4,000 steps/rev.

The motor is an important element in providing good smoothness. Some motor designs are optimized for high-torque output rather than smooth rotation. Others are optimized for smoothness rather than high torque. Ministepping systems are typically offered with a motor as a “packaged” total solution, using a motor that has been selected for its premium smoothness properties.

Ministep systems are sometimes selected to improve positional accuracy. However, with an open-loop system, friction may prevent the theoretical unloaded accuracy from being achieved in practice.

Microstepping Drives

As we mentioned earlier, subdivision of the basic motor step is possible by proportioning the current in the two motor windings. This produces a series of intermediate step positions between the one-phase-on points. It is clearly desirable that these intermediate positions are equally spaced and produce approximately equal torque when the motor is running.

Accurate microstepping places increased demands on the accuracy of current control in the drive, particularly at low current levels. A small phase imbalance that may be barely detectable in a half-step drive can produce unacceptable positioning errors in a microstep system. Pulse-width modulation is frequently used to achieve higher accuracy than can be achieved using a simple threshold system.

The phase currents necessary to produce the intermediate steps follow an approximately sinusoidal profile as shown in Fig. 2.12. However the same profile will not give the optimum response with all motors. Some will work well with a sinusoidal shape, whereas others need a more filled-out or trimmed-down shape (Fig. 2.12). So a microstep drive intended to operate with a variety of motors needs to have provision for adjusting the current profile. The intermediate current levels are usually stored as data in an EPROM, with some means of selecting alternative data sets to give different profiles. The change in profile may be thought of in terms of adding or subtracting a third-harmonic component to or from the basic sine wave.

Fig. 2.12 Microstep current profile

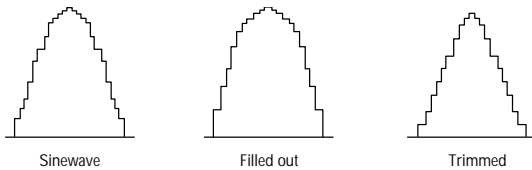

In the case of high-resolution microstep drives producing 10,000 steps per rev or more, the best performance will only be obtained with a particular type of motor. This is one in which the stator teeth are on a 7.5° pitch, giving 48 equal pitches in 360°. In most hybrid steppers, the stator teeth have the same pitch as the rotor teeth, giving equal increments of 7.2°. This latter arrangement tends to give superior torque output, but is less satisfactory as a microstepper since the magnetic poles are "harder" – there is no progressive transfer of tooth alignment from one pole to the next. In fact, with this type of motor, it can be quite difficult to find a current profile that gives good static positioning combined with smooth low-speed rotation. An alternative to producing a 7.5°-pitch stator is to incorporate a slight skew in the rotor teeth. This produces a similar effect and has the benefit of using standard 7.2° laminations throughout. Skewing is also used in DC brush motors as a means of improving smoothness.

Due to this dependence on motor type for performance, it is usual for high-resolution microstep systems to be supplied as a matched motor-drive package.

The Stepper Torque/Speed Curve

We have seen that motor inductance is the factor that opposes rapid changes of current and therefore makes it more difficult to drive a stepper at high speeds. Looking at the torque-speed curve in Fig. 2.13, we can see what is going on. At low speeds, the current has plenty of time to reach the required level and so the average current in the motor is very close to the regulated value from the drive. Changing the regulated current setting or changing to a drive with a different current rating will affect the available torque accordingly.

Fig 2.13 Regulated and voltage-limited regions of the torque-speed curve

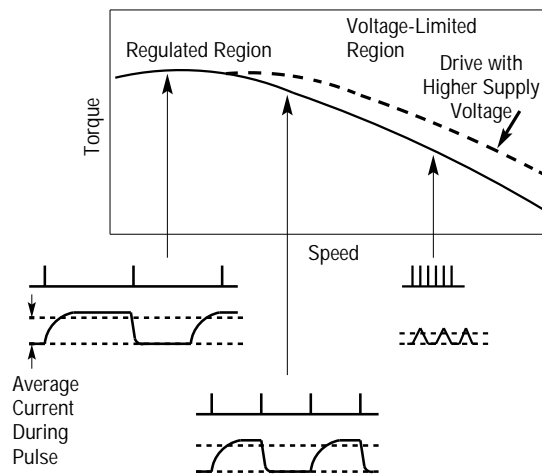

As speed increases, the time taken for the current to rise becomes a significant proportion of the interval between step pulses. This reduces the average current level, so the torque starts to fall off. As speed increases further, the interval between step pulses does not allow the current time to reach a level where the chopping action can begin. Under these conditions, the final value of current depends only on the supply voltage. If the voltage is increased, the current will increase more rapidly and hence will achieve a higher value in the available time. So this region of the curve is described as "voltage limited", as a change in the drive current setting would have no effect. We can conclude that at low speeds the torque depends on the drive current setting, whereas at high speeds it depends on the drive supply voltage. It is clear that high-speed performance is not affected by the drive current setting. Reducing the current simply "flattens out" the torque curve without restricting the ability to run at high speeds. When performance is limited by the available high-speed torque, there is much to be said for running at the lowest current that gives an adequate torque margin. In general, dissipation in motor and drive is reduced and low-speed performance in particular will be smoother with less audible noise.

With a bipolar drive, alternative possibilities exist for the motor connections as shown in Fig. 2.14. An 8-lead motor can be connected with the two halves of each winding either in series or in parallel. With a 6-lead motor, either one half-winding or both half-windings may be connected in series. The alternative connection schemes produce different torque-speed characteristics and also affect the motor's current rating.

Fig. 2.14 Series & parallel connections

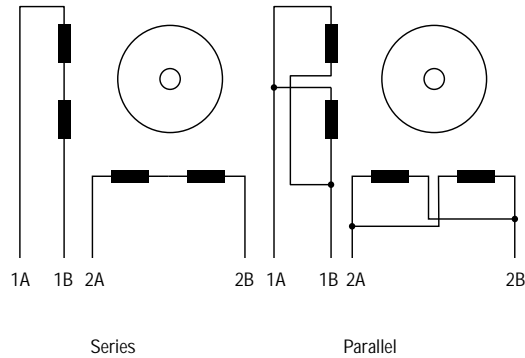
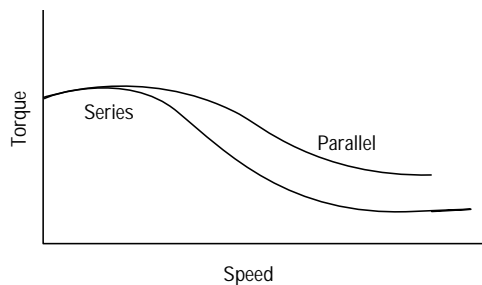

Fig. 2.15 Series & parallel torque/speed curves



Compared with using one half-winding only, connecting both halves in series requires the drive current to flow through twice as many turns. For the same current, this doubles the "amp-turns" and produces a corresponding increase in torque. In practice, the torque increase is seldom as high as 100% due to the non-linearity of the magnetic material. Equally, the same torque will be produced at half the drive current when the windings are in series.

However, having doubled the effective number of turns in the winding means that we have also increased the inductance by a factor of 4. This causes the torque to drop off much more rapidly as speed is increased, and as a result, the series mode is most useful at low speeds. The maximum shaft power obtainable in series is typically half that available in parallel (using the same current setting on the drive).

Connecting the two half-windings of an 8-lead motor in parallel allows the current to divide itself between the two coils. It does not change the effective number of turns and the inductance therefore remains the same. So at a given drive current, the torque characteristic will be the same for two half-windings in parallel as for one of the windings on its own. For this reason, "parallel" in the context of a 6-lead motor refers to the use of one half-winding only.

As has already been mentioned, the current rating of a step motor is determined by the allowable temperature rise. Unless the motor manufacturer's data states otherwise, the rating is a "unipolar" value and assumes both phases of the motor are energized simultaneously. So a current rating of 5A means that the motor will accept 5A flowing in each half-winding.

When the windings of an 8-lead motor are connected in parallel, half of the total resistance is produced. For the same power dissipation in the motor, the current may now be increased by 40%. Therefore, the 5A motor will accept 7A with the windings in parallel, giving a significant increase in available torque. Conversely, connecting the windings in series will double the total resistance and the current rating is reduced by a factor of 1.4, giving a safe current of 3.5A for our 5A-motor in series.

As a general rule, parallel is the preferred connection method as it produces a flatter torque curve and greater shaft power (Fig. 2.15). Series is useful when high torque is required at low speeds, and it allows the motor to produce full torque from a lower-current drive. Care should be taken to avoid overheating the motor in series since its current rating is lower in this mode. Series configurations also carry a greater likelihood of resonance due to the high torque produced in the low-speed region.

DC Brush Motor Drives

Linear and Switching Amplifiers

Linear amplifiers – this type of amplifier operates in such a way that, depending on the direction of motor rotation, either TR1 or TR2 will be in series with the motor and will always have a voltage (V) developed across it (Fig. 2.16).

This characteristic is the primary limitation on the use of linear amplifiers (since there will always be power dissipated in the output stages of the amplifier). To dissipate this power, large transistors and heat sinks will be required, making this type of amplifier unsuitable for use in high power systems. However, the linear amplifier does offer the benefit of low radiated electrical noise.

Fig. 2.16 Linear servo amplifier

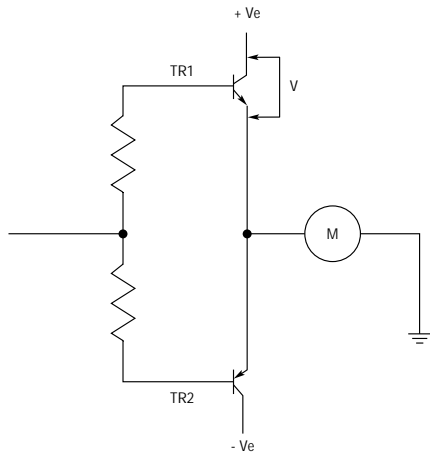

Switching amplifiers – this amplifier is the most commonly used type for all but very low-power requirements and the most commonly used method of output control is by pulse width modulation (PWM).

Power dissipation is greatly reduced since the output transistors are either in an “on” or an “off” state. In the “off” state, no current is conducted and so no power is dissipated. In the “on” state the voltage across the transistors is very low (1-2 volts), so that the amount of power dissipated is small.

Such amplifiers are suitable for a wide range of applications (including high power applications).

The operation of a switching or chopper amplifier is very similar to that of the chopping stepper drive already described. Only one switch set is required to drive a DC brush motor, making the drive simpler. However, the function of a DC drive is to provide a variable current into the motor to control the torque. This may be achieved using either analog or digital techniques.

Analog and Digital Servo Drives

Unlike stepper drives, amplifiers for both brush and brushless servo motors are either analog or digital. The analog drive has been around for many years, whereas the digital drive is a relatively recent innovation. Both types have their merits.

Overview – The Analog Drive

In the traditional analog drive, the desired motor velocity is represented by an analog input voltage usually in the range ± 10 volts. Full forward velocity is represented by +10v, and full reverse by -10v. Zero (0) volts represents the stationary condition and intermediate voltages represent speeds in proportion to the voltage.

The various adjustments needed to tune an analog drive are usually made with potentiometers. With a little experience, this can usually be performed quite quickly, but in some difficult applications it may take longer. Repeating the adjustments on subsequent units may take the same time unless there is an easy way of duplicating the potentiometer settings. For this reason, some proprietary drives use a plug-in “personality card” that may be fitted with preset components. However, this not only increases the cost but may preclude the possibility of fine tuning later.

Overview – The Digital Drive

An alternative to the analog system is the digitally-controlled drive in which tuning is performed by sending data from a terminal or computer. This leads to easy repetition between units and, since such drives are invariably processor-based, facilitates fully-automatic self tuning. The input signal to such a drive may also be an analog voltage but can equally take the form of step and direction signals, like a stepper drive.

Digital drives are used more in conjunction with brushless servo motors than with DC brush motors. Such drives are almost wholly digital with the exception of the power stage that actually delivers current to the motor. Velocity feedback is derived either from an encoder or resolver and again is processed as digital information. It becomes logical to incorporate a position controller within such a drive, so that incoming step and direction signals can be derived from a conventional stepper-type indexer. Equally, the positioner may be controlled by simple commands using a high-level motion control language – see the X-code products in this catalog.

A Comparison of Analog and Digital Drives

The analog drive offers the benefit of lower cost and, in the case of a drive using tach feedback, very high performance. The wide bandwidth of the brush tach allows high gains to be used without inducing jitter at standstill, resulting in a very “stiff” system.

The digital drive, while more costly, is comparatively easy to set up and adjustments can be quickly repeated across several units. Automatic self-tuning can be a distinct advantage where the load parameters are unknown or difficult to measure. The digital drive also offers the possibility of dynamic tuning – sometimes vital where the load inertia changes dramatically during machine operation. Such an option is clearly out of the question with a potentiometer-adjusted drive.

Analog DC Drive Operation

The elements of an analog velocity amplifier are shown in Fig. 2.17. The function of the system is to control motor velocity in response to an analog input voltage.

Fig. 2.17 Elements of an analog servo system

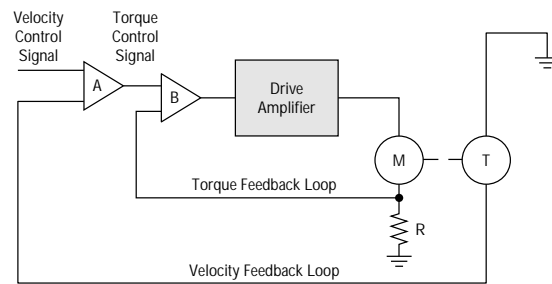

Motor velocity is measured by a tach generator attached to the motor shaft. This produces a voltage proportional to speed that is compared with the incoming velocity demand signal, and the result of this comparison is a torque demand. If the speed is too low, the drive delivers more current, which in turn creates torque to accelerate the load. Similarly, if the speed is too high or the velocity demand is reduced, current flow in the motor will be reversed to produce a braking torque.

This type of amplifier is often referred to as a four-quadrant drive. This means that it can produce both acceleration and braking torque in either direction of rotation. If we draw a diagram representing direction of rotation in one axis and direction of torque in the other (see Fig. 2.18), you will see that the motor can operate in all four "quadrants". By contrast, a simple variable-speed drive capable of running only in one direction and with uncontrolled deceleration would be described as single-quadrant.

Fig. 2.18 Four-quadrant operation

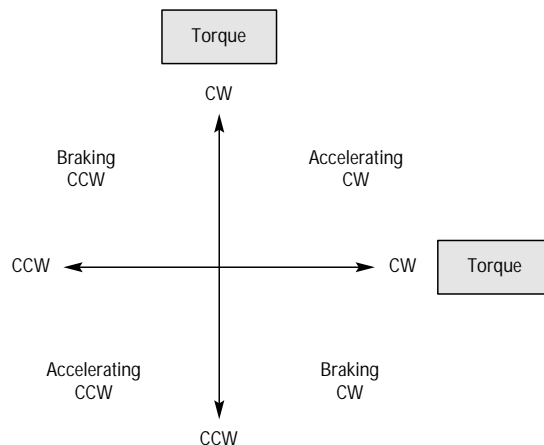

The velocity amplifier in Fig. 2.17 has a high gain so that a small velocity difference will produce a large error signal. In this way, the accuracy of speed control can be made very high even when there are large load changes.

A torque demand from the velocity amplifier amounts to a request for more current in the motor. The control of current is again achieved by a feedback loop that compares the torque demand with the current in the motor. This current is measured by a sense resistor R , which produces a voltage proportional to motor current. This inner feedback loop is frequently referred to as a torque amplifier since its purpose is to create torque in response to a demand from the velocity amplifier.

The torque amplifier alone may be used as the basis of a servo drive. Some types of position controller generate a torque output signal rather than a velocity demand, and there are also applications in which torque rather than speed is of primary interest (winding material onto a drum, for instance). Most analog drives can be easily configured either as velocity or torque amplifiers by means of a switch or jumper links. In practice, the input signal is still taken to the same point, but the velocity amplifier is bypassed.

Fig. 2.19 Digital servo drive

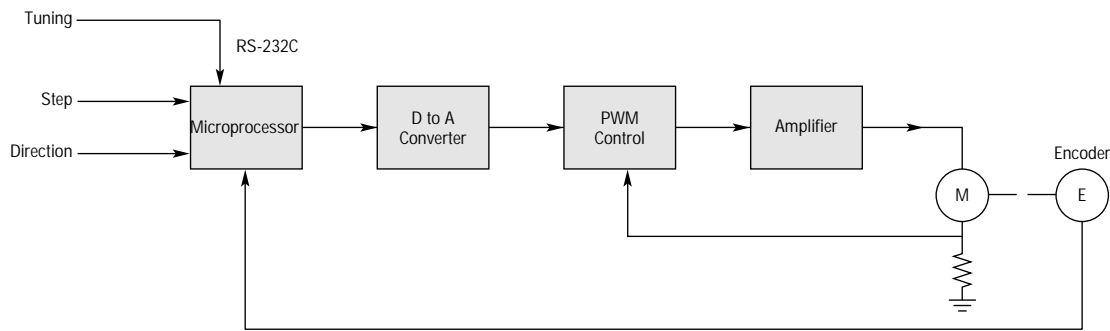

Digital Servo Drive Operation

Fig. 2.19 shows the components of a digital drive for a servo motor. All the main control functions are carried out by the microprocessor, which drives a D-to-A converter to produce an analog torque demand signal. From this point on, the drive is very much like an analog servo amplifier.

Feedback information is derived from an encoder attached to the motor shaft. The encoder generates a pulse stream from which the processor can determine the distance travelled, and by calculating the pulse frequency it is possible to measure velocity.

The digital drive performs the same operations as its analog counterpart, but does so by solving a series of equations. The microprocessor is programmed with a mathematical model (or "algorithm") of the equivalent analog system. This model predicts the behavior of the system. In response to a given input demand and output position. It also takes into account additional information like the output velocity, the rate of change of the input and the various tuning settings.

To solve all the equations takes a finite amount of time, even with a fast processor – this time is typically between 100µs and 2ms. During this time, the torque demand must remain constant at its previously-calculated value and there will be no response to a change at the input or output. This "update time" therefore becomes a critical factor in the performance of a digital servo and in a high-performance system it must be kept to a minimum.

The tuning of a digital servo is performed either by pushbuttons or by sending numerical data from a computer or terminal. No potentiometer adjustments are involved. The tuning data is used to set various coefficients in the servo algorithm and hence determines the behavior of the system. Even if the tuning is carried out using pushbuttons, the final values can be uploaded to a terminal to allow easy repetition.

In some applications, the load inertia varies between wide limits – think of an arm robot that starts off unloaded and later carries a heavy load at full extension. The change in inertia may well be a factor of 20 or more, and such a change requires that the drive is re-tuned to maintain stable performance. This is simply achieved by sending the new tuning values at the appropriate point in the operating cycle.

Brushless Motor Drives

The trapezoidal drive

Fig. 2.20 shows a simplified layout of the drive for a three-phase trapezoidal motor. The switch set is based on the familiar H-bridge, but uses three bridge legs instead of two. The motor windings are connected between the three bridge legs as shown, with no connection to the star point at the junction of the windings. By turning on the appropriate two transistors in the bridge, current can be made to flow in either direction through any two motor windings. At any particular time, the required current path depends on rotor position and direction of rotation, so the bridge transistors are selected by logic driven from the commutation encoder.

A PWM recirculating chopper system controls the current in the same way as in the DC brush drive described previously. The required current feedback information is provided by sense resistors connected in series with two of the motor leads. The voltage signals derived from these resistors must be decoded and combined to provide a useful current reference, and the circuit that does this also uses the commutation encoder to determine how to interpret the information. In fact, this is not a simple process because the

relatively small feedback voltage (about 1V) must be separated from the large voltage excursions generated by the chopping system (240V in the case of a typical high-power drive).

The input stages of the brushless drive follow the same pattern as a conventional analog brush drive (using a high-gain velocity amplifier that generates the torque demand signal). Velocity feedback can be derived in a number of ways, but it is clearly desirable to use a brushless method in conjunction with a brushless motor. Some motors incorporate a brushless tach generator that produces multi-phase AC outputs. These signals have to be processed in a similar way to the current feedback information using additional data from a tach encoder. Again, this is not a particularly straightforward process and it is difficult to obtain a smooth, glitch-free feedback signal. A more satisfactory alternative is to use a high-resolution optical encoder and convert the encoder pulse frequency to an analog voltage. The encoder can also be used as the feedback device for a position controller.

Fig. 2.20 Simplified trapezoidal brushless servo drive

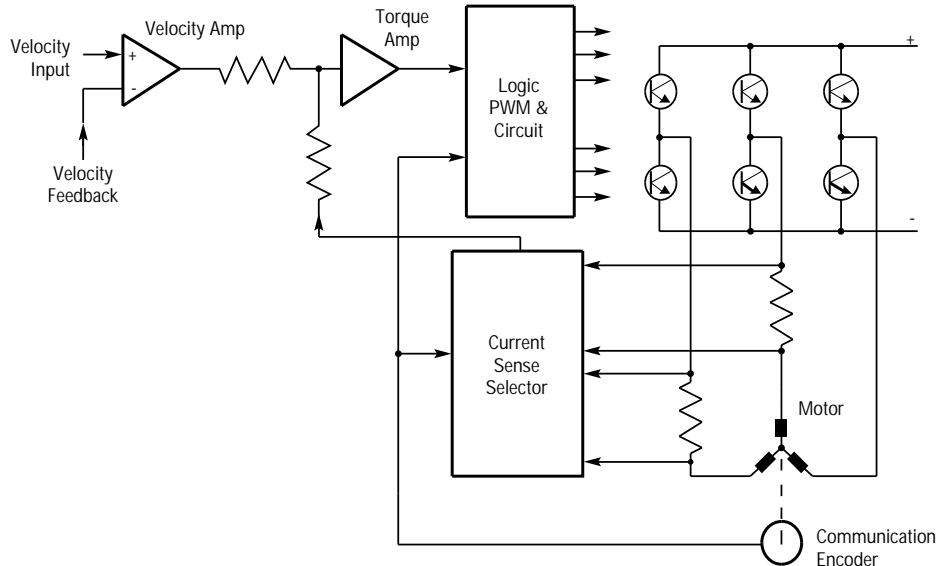

The Sine Wave Drive

Sine wave brushless motors can be two- or three-phase, and the drive we'll look at is for the two-phase version (see Fig. 2.21). This uses two H-bridges to control current in the two motor windings, and the power section of this drive closely resembles a pair of DC brush drives. By contrast with the previous example, this drive uses a digital processor-based control section that takes its input in the form of step and direction signals. We need to generate currents in the two motor windings that follow a sine and cosine pattern as the shaft rotates. The drive shown in Fig. 2.21 uses a brushless resolver and a resolver-to-digital converter (RDC) to detect the shaft position. From this, we will get a number that can be fed to a reference table to determine the instantaneous current values for that particular shaft position. Bear in mind that the reference table will only indicate *relative* currents in the two windings—the absolute

values will depend on the torque demand at the time. So the processor must multiply the sine and cosine values by the torque demand to get the final value of current in each phase. The resulting numbers are fed to D-to-A converters that produce an analog voltage proportional to demanded current. This is fed to the two PWM chopper amplifiers.

Commutation information for a sine wave drive may also be derived from an absolute or incremental optical encoder. An incremental encoder will be less expensive for the same resolution, but requires some form of initialization at power-up to establish the required 90° torque angle.

A “pseudo-sine wave” drive using feedback from a low-resolution absolute encoder can offer a cost-effective alternative. The pseudo sine wave drive gives superior performance to the trapezoidal drive at lower cost than the standard high-resolution sine wave system.

Fig. 2.21 Two-phase sine wave brushless drive

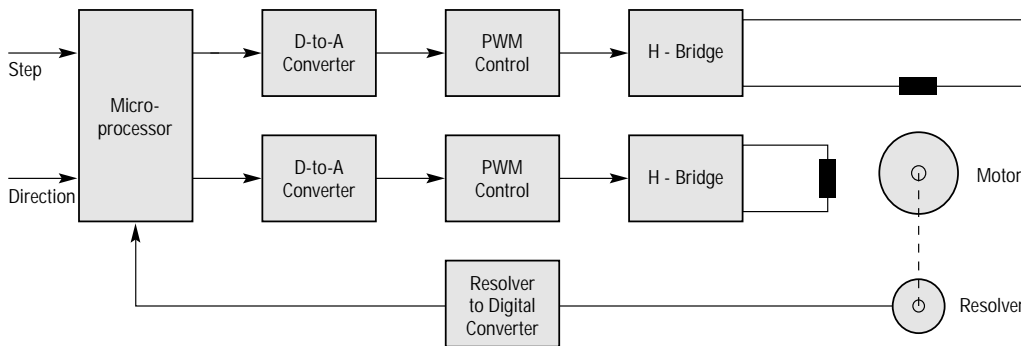

Tuning a Servo System

Any closed-loop servo system, whether analog or digital, will require some tuning. This is the process of adjusting the characteristics of the servo so that it follows the input signal as closely as possible.

Why is tuning necessary?

A servo system is error-driven, in other words, there must be a difference between the input and the output before the servo will begin moving to reduce the error. The "gain" of the system determines how hard the servo tries to reduce the error. A high-gain system can produce large correcting torques when the error is very small. A high gain is required if the output is to follow the input faithfully with minimal error.

Now a servo motor and its load both have inertia, which the servo amplifier must accelerate and decelerate while attempting to follow a change at the input. The presence of the inertia will tend to result in over-correction, with the system oscillating or "ringing" beyond either side of its target (Fig. 3.1). This ringing must be damped, but too much damping will cause the response to be sluggish. When we tune a servo, we are trying to achieve the fastest response with little or no overshoot.

Fig. 3.1 System response characteristics

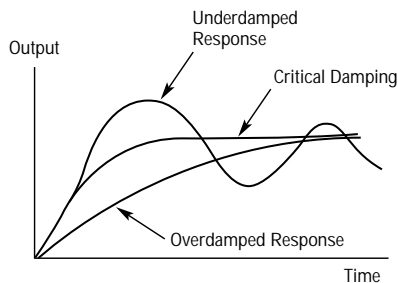

In practice, tuning a servo means adjusting potentiometers in an analog drive or changing gain values numerically in a digital system. To carry out this process effectively, it helps to understand what's going on in the drive. Unfortunately, the theory behind servo system behavior, though well understood, does not reveal itself to most of us without a struggle. So we'll use a simplified approach to explain the tuning process in a typical analog velocity servo. Bear in mind that this simplified approach does not necessarily account for all aspects of servo behavior.

A Brief Look at Servo Theory

A servo is a closed-loop system with negative feedback. If you make the feedback positive, you will have an oscillator. So for the servo to work properly, the feedback must always remain negative, otherwise the servo becomes unstable. In practice, it's not as clear-cut as this. The servo can *almost* become an oscillator, in which case it overshoots and rings following a rapid change at the input.

So why doesn't the feedback stay negative all the time?

To answer this, we need to clarify what we mean by "negative". In this context, it means that the input and feedback signals are in antiphase. If the input is driven with a low frequency sinewave, the feedback signal (which will also be a sinewave) is displaced in phase by 180°. The 180°-phase displacement is achieved by an inversion at the input of the amplifier. (In practice it's achieved simply by connecting the tach the right way round – connect it the wrong way and the motor runs away.)

The very nature of a servo system is such that its characteristics vary with frequency, and this includes phase characteristics. So feedback that starts out negative at low frequencies can turn positive at high frequencies. The result can be overshoot, ringing or ultimately continuous oscillation.

We've said that the purpose of servo tuning is to get the best possible performance from the system without running into instability. We need to compensate for the characteristics of the servo components and maintain an adequate stability margin.

What determines whether the system will be stable or not?

Closed-loop systems can be difficult to analyze because everything is interactive. The output gets fed back to the input in antiphase and virtually cancels it out, so there seems to be nothing left to measure. The best way to determine what's going on is to *open the loop* and then see what happens.

Fig. 3.2 Closed-loop velocity servo

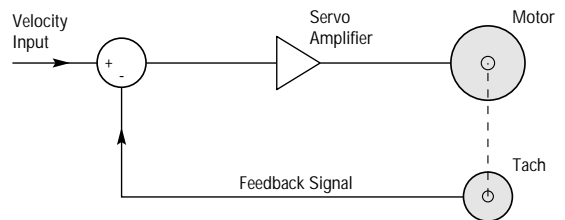
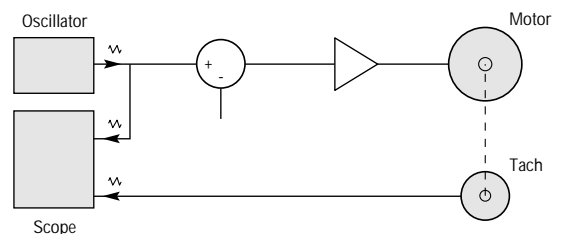
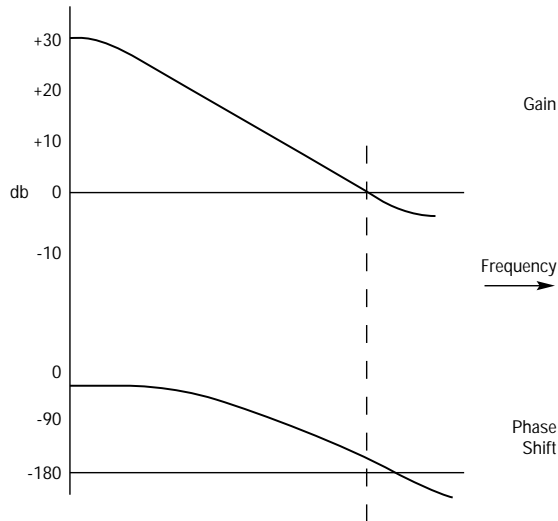

Fig. 3.3A Measuring open-loop characteristics



Measuring the open-loop characteristic allows us to find out what the output (and therefore the feedback) signal will be in response to a particular input. We need to measure the *gain* and *phase shift* at different frequencies, and we can plot the results graphically. For a typical servo system, the results might look like this:

Fig. 3.3B Open-loop gain and phase characteristics



The gain scale is in decibels (dB), which is a logarithmic scale (a 6dB decrease corresponds to a reduction in amplitude of about 50%). The 0dB line represents an open-loop gain of one (unity), so at this frequency the input and output signals will have the same amplitude. The falling response in the gain characteristics is mainly due to the inertia of the motor itself.

The phase scale is in degrees and shows the phase lag between input and output. Remember that the feedback loop is arranged to give negative feedback at low frequencies, (i.e., 180° phase difference). If the additional phase lag introduced by the system components reaches 180°, the feedback signal is now shifted by 360° and therefore back in phase with the input. We need to make sure that at no point do we get a feedback signal larger than the original input and in phase with it. This would amount to positive feedback, producing an ever-increasing output leading to oscillation.

Fortunately, it is possible to predict quite accurately the gain and phase characteristics of most servo systems, provided that you have the necessary mathematical expertise and sufficient data about the system. So in practice, it is seldom necessary to measure these characteristics unless you have a particular stability problem that persists.

We've said that a problem can occur when there is a *phase shift* of 180° round the loop. When this happens, the *open-loop gain* must be less than one (1) so that the signal fed back is smaller than the input. So here is a basic requirement for a stable system:

The open-loop gain must be less than unity when the phase shift is 180°.

When this condition is only just met (i.e., the phase shift is near to 180° at unity gain) the system will ring after a fast change on the input.

Fig. 3.4 Underdamped response

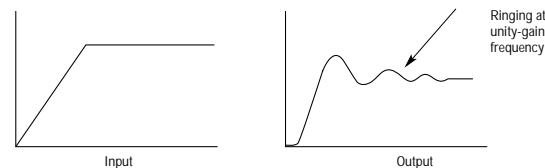

Characteristics of a Practical Servo System

Typical open-loop gain and phase characteristics of an unloaded drive-motor-tach system will look something like Fig. 3.5.

Fig. 3.5 Characteristics of a practical system

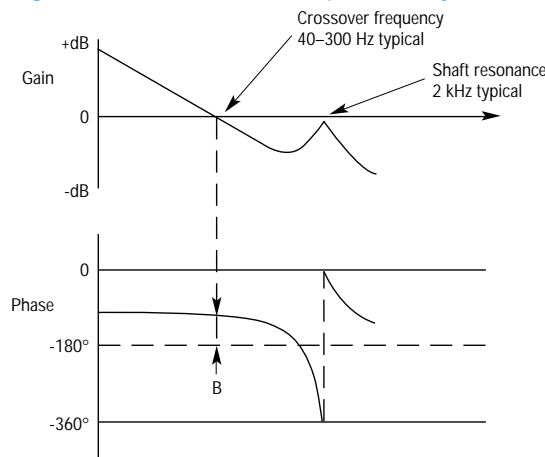

The first thing we notice is the pronounced spike in the gain plot at a frequency of around 2kHz. This is caused by shaft resonance, torsional oscillation in the shaft between the motor and the tach. Observe that the phase plot drive dramatically through the critical 180° line at this point. This means that the loop gain at this frequency must be less than unity (0dB), otherwise the system will oscillate.

The TIME CONSTANT control determines the frequency at which the gain of the amplifier starts to roll off. You can think of it rather like the treble control on an audio amplifier. When we adjust the time constant control, we are changing the high-frequency gain to keep the gain spike at 2kHz just below 0dB. With too high a gain (time constant too low) the motor will whistle at about 2kHz.

The second point of interest is the CROSSOVER FREQUENCY, which is the frequency at which the gain curve passes through 0dB (unity gain). This frequency is typically between 40 and 300Hz. On the phase plot, β (beta) is the *phase margin* at the crossover frequency. If β is very small, the system will overshoot and ring at the crossover frequency. So β represents the degree of damping – the system will be heavily damped if β is large.

The DAMPING control increases the phase margin at the crossover frequency. It operates by applying lead compensation, sometimes called acceleration feedback. The compensation network creates a *phase lead* in the region of the crossover frequency, which increases the phase margin and therefore improves the stability.

Increasing the damping also tends to reduce the gain at the 2kHz peak, allowing a higher gain to be used before instability occurs. Therefore, the time constant should be re-adjusted after the damping has been set up.

What's the effect of adding load inertia?

An external load will alter both the gain and phase characteristics. Not only will the overall gain be reduced owing to the larger inertia, but an additional gain spike will be introduced due to torsional oscillation between the motor and the load. This gain spike may well be larger than the original 2kHz spike, in which case the motor will start to buzz at a lower frequency when the time constant is adjusted.

Fig. 3.6 Characteristics of a system with inertial load

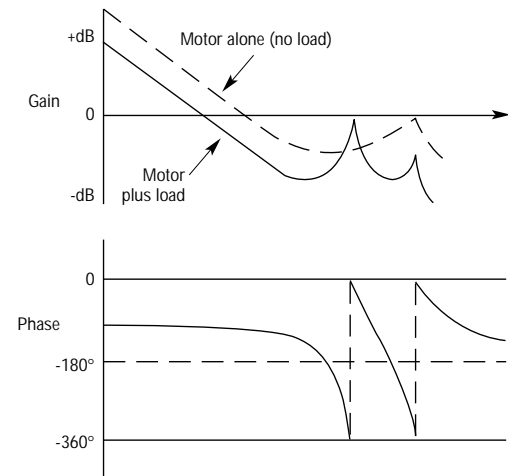

The amplitude of this second spike will depend on the compliance or stiffness of the coupling between motor and load. A springy coupling will produce a large gain spike; this means having to reduce the gain to prevent oscillation, resulting in poorer system stiffness and slower response. So, if you're after a snappy performance, it's important to use a torsionally-stiff coupling between the motor and the load.

Tachometers

A permanent magnet DC motor may be used as a tachometer. When driven mechanically, this motor generates an output voltage that is proportional to shaft speed (see Fig. 4.1). The other main requirements for a tachometer are that the output voltage should be smooth over the operating range and that the output should be stabilized against temperature variations.

Small permanent magnet DC “motors” are frequently used in servo systems as speed sensing devices. These systems usually incorporate thermistor temperature compensation and make use of a silver commutator and silver loaded brushes to improve commutation reliability at low speeds and at the low currents, which are typical of this application.

To combine high performance and low cost, DC-servo motor designs often incorporate a tachometer mounted on the motor shaft and enclosed within the motor housing (Fig. 4.1).

Fig. 4.1 Tachometer output characteristics

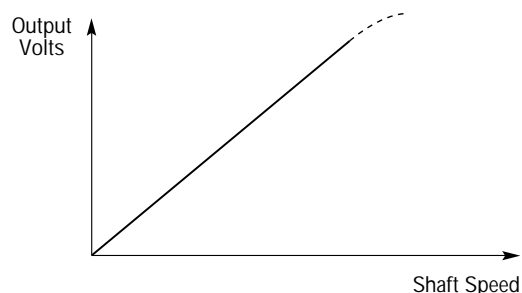
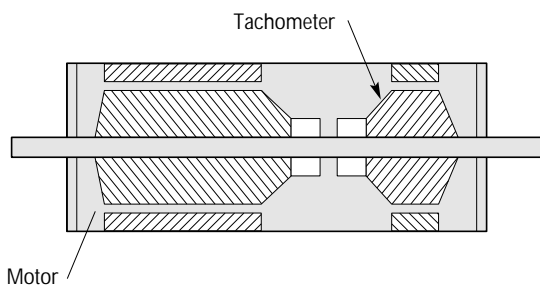

Fig. 4.2 Motor with integral tachometer



Optical Encoders

In servo control systems, where mechanical position is required to be controlled, some form of position sensing device is needed. There are a number of types in use: magnetic, contact, resistive, and optical. However, for accurate position control, the most commonly used device is the optical encoder. There are two forms of this encoder – absolute and incremental.

Optical encoders operate by means of a grating, that moves between a light source and a detector. When light passes through the transparent areas of the grating, an output is seen from the detector. For increased resolution, the light source is collimated and a mask is placed between the grating and the detector. The grating and the mask produce a shuttering effect, so that only when their transparent sections are in alignment is light allowed to pass to the detector (Fig. 4.3).

Fig. 4.3 Principle of optical encoder

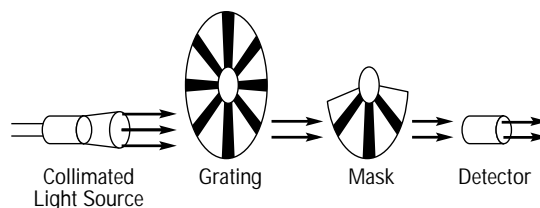

An incremental encoder generates a pulse for a given increment of shaft rotation (rotary encoder), or a pulse for a given linear distance travelled (linear encoder). Total distance travelled or shaft angular rotation is determined by counting the encoder output pulses.

An absolute encoder has a number of output channels, such that every shaft position may be described by its own unique code. The higher the resolution the more output channels are required.

The Basics of Incremental Encoders

Since cost is an important factor in most industrial applications, and resetting to a known zero point following power failure is seldom a problem, the rotary incremental encoder is the type most favored by system designers. Its main element is a shaft mounted disc carrying a grating, which rotates with the grating between a light source and a masked detector. The light source may be a light emitting diode or an incandescent lamp, and the detector is usually a phototransistor or more commonly a photo-voltaic diode. Such a simple system, providing a single low-level output, is unlikely to be frequently encountered, since quite apart from its low output signal, it has a DC offset that is temperature dependent, making the signal difficult to use (Fig. 4.4).

Fig. 4.4 Encoder output voltage

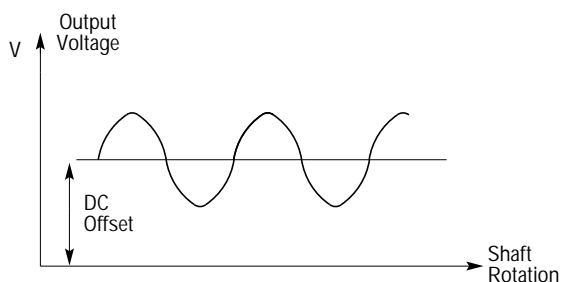

In practice, two photodiodes are used with two masks, arranged to produce signals with 180° phase difference for each channel, the two diode outputs being subtracted so as to cancel the DC offset (Fig. 4.5). This quasi-sinusoidal output may be used unprocessed, but more often it is either amplified or used to produce a square wave output. Hence, incremental rotary encoders may have sine wave or square wave outputs, and usually have up to three output channels.

Fig. 4.5 Output from dual photodiode system

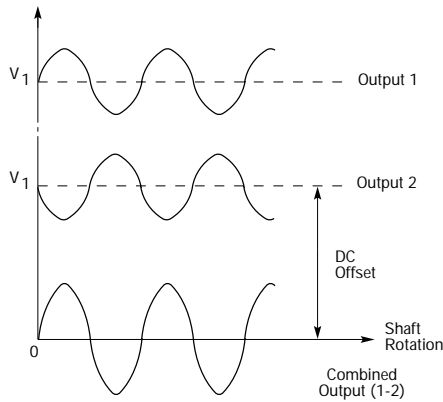

A two-channel encoder, as well as giving position of the encoder shaft, can also provide information on the direction of rotation by examination of the signals to identify the leading channel. This is possible since the channels are normally arranged to be in quadrature (i.e., 90° phase shifted: Fig. 4.6).

For most machine tool or positioning applications, a third channel known as the index channel or Z channel is also included. This gives a single output pulse per revolution and is used when establishing the zero position.

Fig. 4.6 Quadrature output signals

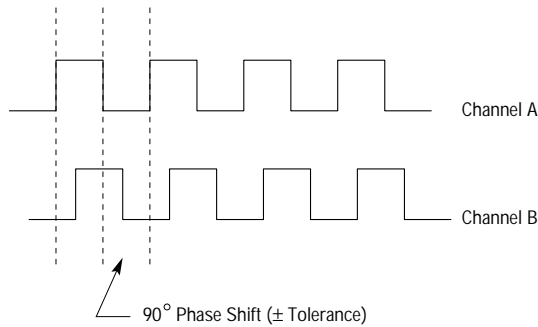

Fig. 4.6 shows that for each complete square wave from channel A, if channel B output is also considered during the same period, four pulse edges will occur. This allows the resolution of the encoder to be quadrupled by processing the A and B outputs to produce a separate pulse for each square wave edge. For this process to be effective, however, it is important that quadrature is maintained within the necessary tolerance so that the pulses do not run into one another.

Square wave output encoders are generally available in a wide range of resolutions (up to about 5000 lines/rev), and with a variety of different output configurations, some of which are listed below.

TTL (Transistor-Transistor Logic) – This is a commonly available output, compatible with TTL logic levels, and normally requiring a 5 volt supply. TTL outputs are also available in an open-collector configuration which allows the system designer to choose from a variety of pull-up resistor value.

CMOS (Complimentary Metal-Oxide Semiconductor) – Available for compatibility with the higher logic levels, it normally used with CMOS devices.

Line driver – These are low-output impedance devices designed for driving signals over a long distance, and are usually used with a matched receiver.

Complementary outputs – Outputs derived from each channel give a pair of signals, 180° out of phase. These are useful where maximum immunity to interference is required.

Noise problems

The control system for a machine is normally screened and protected within a metal cabinet. An encoder may be similarly housed. However, unless suitable precautions are taken, the cable connecting the two can be a source of trouble due to its picking up electrical noise. This noise may result in the loss or gain of signal counts, giving rise to incorrect data input and loss of position.

Fig. 4.7 Corruption of encoder signal by noise

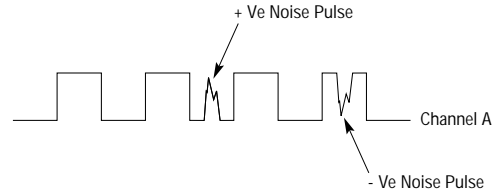

Fig. 4.7, shows how the introduction of two noise pulses has converted a four-pulse train into one of six pulses.

A number of techniques are available to overcome problems due to noise. The most obvious resolution is to use shielded interconnecting cables.

However, since the signals may be at a low level (5 volts) and may be generated by a high-impedance source, it may be necessary to go to further lengths to eliminate the problem.

The most effective way to resolve the problem is to use an encoder with complementary outputs (Fig. 4.8) and connect this to the control system by means of shielded, twisted-pair cable.

The two outputs are processed by the control circuitry so that the required signal can be reconstituted without the noise.

Fig. 4.8 Complementary output signals

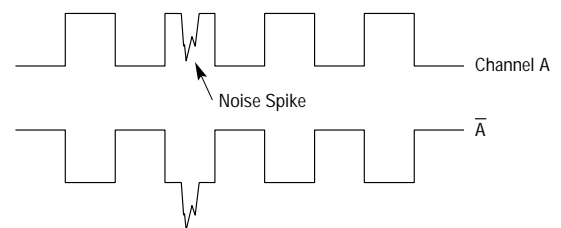

If the A signal is inverted and is fed with the A signal into an OR gate (whose output depends on one signal or the other being present), the resultant output will be a square wave (Fig. 4.9).

Fig. 4.9 Reduction of noise in a complementary system

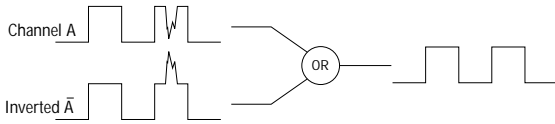

The simple interconnection of encoder and controller with channel outputs at low level may be satisfactory in electrically “clean” environments or where interconnections are very short. In cases where long interconnections are necessary or where the environment is “noisy”, complementary line driver outputs will be needed, and interconnections should be made with shielded, twisted-pair cable.

Factors Affecting Accuracy

Slew rate (speed) – An incremental rotary encoder will have a maximum frequency at which it will operate (typically 100KHz), and the maximum rotational speed, or slew rate, will be determined by this frequency. Beyond this, the output will become unreliable and accuracy will be affected.

Consider a 600-line encoder rotated at 1rpm (gives an output of 10Hz). If the maximum operating frequency of the encoder is 50KHz, its speed will be limited to 5000 times this (i.e., $50\text{KHz} \cdot 10\text{Hz} = 5000 \text{ rpm}$).

If an encoder is rotated at speeds higher than its design maximum, there may be conditions set up that will be detrimental to the mechanical components of the assembly. This could damage the system and affect encoder accuracy.

Quantization error – All digital systems have difficulty, interpolating between output pulses. Therefore, knowledge of position will be accurate only to the grating width (Fig. 4.10).

Fig. 4.10 Encoder quantization error

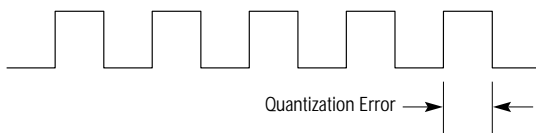

Quantization error = $F(1,2N)$ ($N = \#$ of lines/disk rotation)

Eccentricity

This may be caused by bearing play, shaft run out, incorrect assembly of the disc on its hub or the hub on the shaft. Eccentricity may cause a number of different error conditions.

a) **Amplitude Modulation** – In a sine wave encoder, eccentricity will be apparent as amplitude modulation (Fig. 4.11).

Fig. 4.11 Amplitude modulation caused by eccentricity

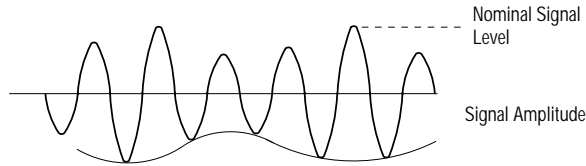

b) **Frequency modulation** – As the encoder is rotated at constant speed, the frequency of the output will change at a regular rate (Fig. 4.12). If viewed on an oscilloscope, this effect will appear as “jitter” on the trace.

Fig. 4.12 Encoder frequency modulation

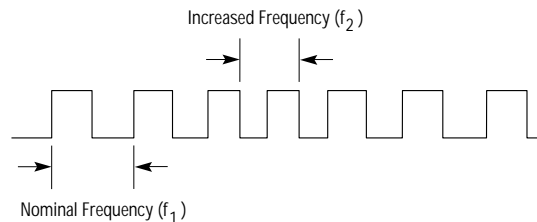

c) **Inter-channel jitter** – If the optical detectors for the two encoder output channels are separated by an angular distance on the same radius, then any “jitter” will appear at different times on the two channels, resulting in “inter-channel jitter”.

Environmental Considerations

Like electrical noise, other environmental factors should be considered before installing an optical encoder.

In particular, temperature and humidity should be considered (consult manufacturers’ specifications).

In environments contaminated with dust, oil vapor or other potentially damaging substances, it may be necessary to ensure that the encoder is enclosed within a sealed casing.

Mechanical Construction

Shaft encoder (Fig. 4.13). In this type of encoder, which may be either incremental or absolute, the electronics are normally supported on a substantial mounting plate that houses the bearings and shaft. The shaft protrudes from the bearings on the "outside" of the encoder, for connection to the rotating system, and on the "inside", so that the encoder disc may be mounted in the appropriate position relative to the light source and detector. The internal parts are covered by an outer casing, through which the interconnecting leads pass.

Fig. 4.13 Shaft encoder

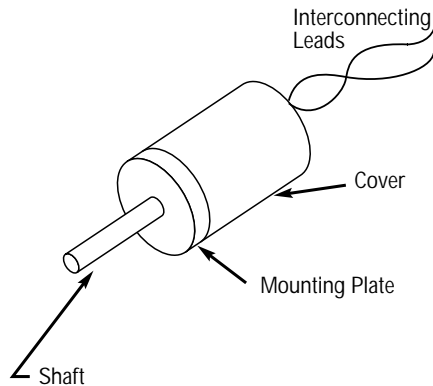

For use in extreme environmental or industrial conditions, the whole enclosure may be specified to a more substantial standard (heavy duty) with sealed bearings and sealing between the mounting plate and cover. Also the external electrical connections may be brought out through a high quality connector.

Modular or kit encoder (Fig. 4.14). These are available in a number of forms, their principal advantage being that of reduced cost.

Fig. 4.14 Modular encoder

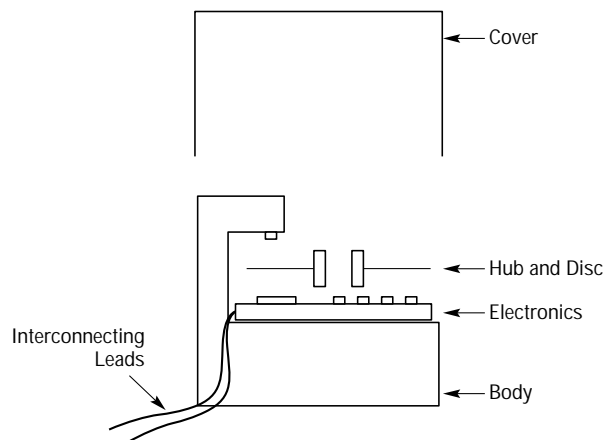

Since many servo motors have a double-ended shaft, it is a simple matter to fit a kit encoder onto a motor.

The kit encoder will usually be less robust than the shaft encoder, but this need not be a problem if the motor is mounted so that the encoder is protected. If this cannot be done, it will normally be possible to fit a suitable cover over the encoder.

A typical kit encoder will include a body, on which will be mounted the electronic components and a hub and disc assembly for fitting to the shaft. Some form of cover will also be provided, mainly to exclude external light and provide some mechanical protection.

Linear encoder. These encoders are used where it is required to make direct measurement of linear movement. They comprise a linear scale (which may be from a few millimeters to a meter or more in length), and a read head. They may be incremental or absolute and their resolution is expressed in lines per unit length (normally lines/inch or lines/cm).

Basics of Absolute Encoders

An absolute encoder is a position verification device that provides unique position information for each shaft location. The location is independent of all other locations, unlike the incremental encoder, where a count from a reference is required to determine position.

Fig. 4.15 Absolute disk



Fig. 4.16 Incremental disk



In an absolute encoder, there are several concentric tracks, unlike the incremental encoder, with its single track. Each track has an independent light source. As the light passes through a slot, a high state (true "1") is created. If light does not pass through the disk, a low state (false "0") is created. The position of the shaft can be identified through the pattern of 1's and 0's.

The tracks of an absolute encoder vary in slot size, moving from smaller at the outside edge to larger toward the center. The pattern of slots is also staggered with respect to preceding and succeeding tracks. The number of tracks determines the amount of position information that can be derived from the encoder disk – resolution. For example, if the disk has ten tracks, the resolution of the encoder would usually be 1,024 positions per revolution or 2^{10} .

For reliability, it is desirable to have the disks constructed of metal rather than glass. A metal disk is not as fragile, and has lower inertia.

Fig. 4.17 Absolute encoder output

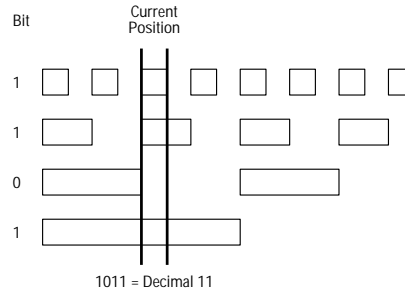

The disk pattern of an absolute encoder is in machine readable code, usually binary, grey code or a variety of grey. The figure above represents a simple binary output with four bits of information. The current location is equivalent to the decimal number 11. Moving to the right from the current position, the next decimal number is 10 (1-0-1-0 binary). Moving to the left from the current position, the next position would be 12 (1-1-0-0).

Fig. 4.18 Multi-turn absolute encoders

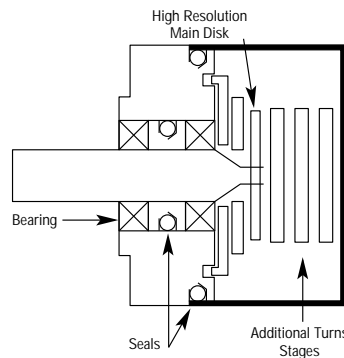

Gearing an additional absolute disk to the primary high-resolution disk provides for turns counting, so that unique position information is available over multiple revolutions.

Here is an example of how an encoder with 1,024 counts per revolution becomes an absolute device for 524,288 discrete positions.

The primary high-resolution disk has 1,024 discrete positions per revolution. A second disk with 3 tracks of information will be attached to the high-resolution disk geared 8:1. The absolute encoder now has 8 complete turns of the shaft or 8,192 discrete positions. Adding a third disk geared 8:1 will provide for 64 turns of absolute positions. In theory, additional disks could continue to be incorporated. But in practice, most encoders stop at or below 512 turns. Encoders using this technique are called multi-turn absolute encoders. This same technique can be incorporated in a rack and pinion style linear encoder resulting in long lengths of discrete absolute locations.

Advantages of Absolute Encoders

Rotary and linear absolute encoders offer a number of significant advantages in industrial motion control and process control applications.

No Position Loss During Power Down or Loss of Power

An absolute encoder is not a counting device like an incremental encoder, because an absolute system reads actual shaft position. The lack of power does not cause the encoder lose position information.

Whenever power is supplied to an absolute system, it can read the current position immediately. In a facility where frequent power failures are common, an absolute encoder is a necessity.

Operation in Electrically Noisy Environments
Equipment such as welders and motor starters often generate electrical noise that can often look like encoder pulses to an incremental counter. Electrical noise does not alter the discrete position that an absolute system reads.

High-speed Long-distance Data Transfer
Use of a serial interface such as RS-422 gives the user the option of transmitting absolute position information over as much as 4,000 feet.

Eliminate Go Home or Referenced Starting Point

The need to find a home position or a reference point is not required with an absolute encoding system since an absolute system always knows its location. In many motion control applications, it is difficult or impossible to find a home reference point. This situation occurs in multi-axis machines and on machines that can't reverse direction. This feature will be particularly important in a "lights-out" manufacturing facility. Significant cost savings is realized in reduced scrap and set-up time resulting from a power loss.

Provide Reliable Position Information in High-speed Applications

The counting device is often the factor limiting the use of incremental encoders in high-speed applications. The counter is often limited to a maximum pulse input of 100 KHz. An absolute encoder does not require a counting device or continuous observation of the shaft or load location. This attribute allows the absolute encoder to be applied in high-speed and high-resolution applications.

Resolvers

A resolver is, in principle, a rotating transformer. If we consider two windings, A and B (Fig. 4.19), and if we feed winding B with a sinusoidal voltage, then a voltage will be induced into winding A. If we rotate winding B, the induced voltage will be at maximum when the planes of A and B are parallel and will be at minimum when they are at right angles. Also, the voltage induced into A will vary sinusoidally at the frequency of rotation of B so that $E_{OA} = E_i \sin \theta$. If we introduce a third winding (C), positioned at right angles to winding A, then as we rotate B, a voltage will be induced into this winding and this voltage will vary as the cosine of the angle θ , so that $E_{OC} = E_i \cos \theta$

Fig. 4.19 Resolver principle

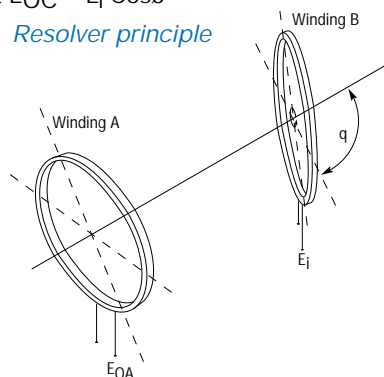

Referring to Fig 4.20, we can see that if we are able to measure the relative amplitudes of the two winding (A & C) outputs at a particular point in the cycle, these two outputs will be unique to that position.

Fig. 4.20 Resolver output

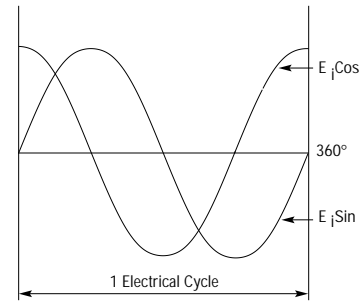

The information output from the two phases will usually be converted from analog to digital form, for use in a digital positioning system, by means of a resolver-to-digital converter (Fig. 4.21). Resolutions up to 65,536 counts per revolution are typical of this type of system.

Fig. 4.21 Resolver-to-digital converter

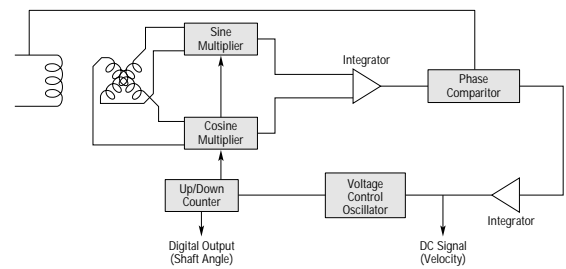

In addition to position information, speed and direction information may also be derived. The resolver is an absolute position feedback device. Within each electrical cycle, Phase A and Phase B maintain a constant (fixed) relationship.

The excitation voltage E_i may be coupled to the rotating winding by slip rings and brushes, though this arrangement is a disadvantage when used with a brushless motor. In such applications, a brushless resolver may be used so that the excitation voltage is inductively coupled to the rotor winding (Fig. 4.22).

Fig. 4.22 Brushless resolver

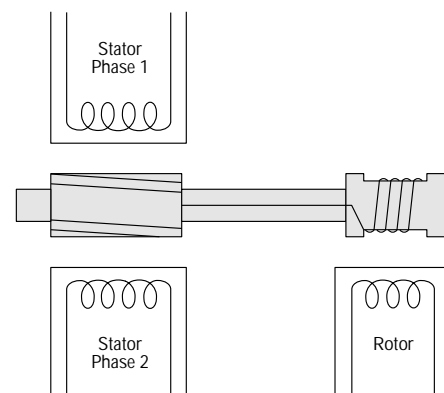

Machine Control

Many industrial designers are concerned with controlling an entire process. Motion control is one important and influential aspect of complete machine control. The primary elements of machine control include:

Fig. 5.1 Primary machine control elements

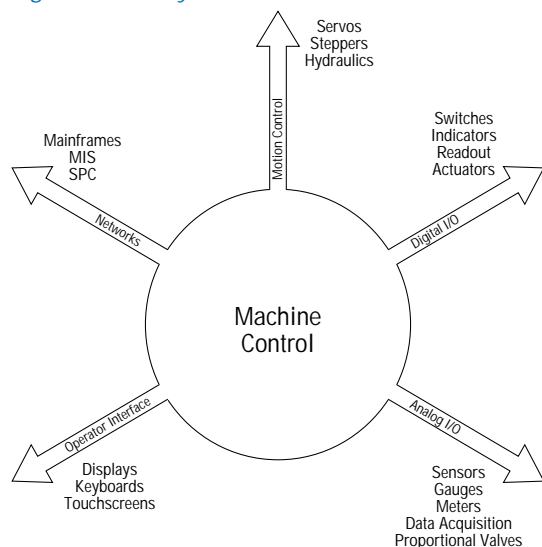

Motion Control: For precise programmable load movement using a servo motor, stepper motor, or hydraulic actuators. Feedback elements are often employed.

Analog and Digital I/O: For actuation of an external process, devices such as solenoids, cutters, heaters, valves, etc.

Operator Interface: For flexible interaction with the machine process for both setup and on-line variations. Touchscreens, data pads, and thumbwheels are examples.

Communications Support: For process monitoring, diagnostics and data transfer with peripheral systems.

There are many different machine control architectures that integrate these elements. Each results in varying levels of complexity and integration of both motion and non-motion elements. PLC-based, bus-based and integrated solutions are all commercially available. Your selection of a machine control strategy will often be based on performance, total application cost, and technology experience.

PLC-based Control

The PLC-based architecture is utilized for I/O intensive control applications. Based upon banks of relays that are scanned, or polled, by a central processor, the PLC provides a low-cost option for those familiar with its ladder logic programming language. Integration of the motion, I/O, operator interface, and communication are usually supported through additional cards that are plugged in its backplane.

The addition of scanning points decreases the polling rate of any individual point, and can thus lead to lower machine response. Because PLCs

have not historically concentrated on motion control, plug-in indexers or those that communicate over BCD are preferable. Because these indexer boards often include their own microprocessor, they prevent slow polling rates, but incorporate a separate programming language. In general, this compromise is acceptable for all but the most complicated motion/machine applications.

Bus-based Systems

Bus-based machine control systems are common in today's industrial environment. STD, VME and PC-AT are only a few of the numerous options. Most of these options can operate through a standard operating system (DOS, OS/2, OS/9) that can be used to program add-on cards for I/O, motion and communication interfaces. Flexible graphical operator interfaces remain one of the computer's major advantages.

Some successful examples of bus-based machine control applications include gear grinding and dressing, PCB placement machines, hard disk manufacturing, and automotive glass bending. Wherever intensive communications or data processing are required, the benefits of the bus structure can be realized.

There are some disadvantages to the bus-based machine control system that relate to the amount of integration between the motion and I/O structure. Separate cards are required for each, resulting in a need for software integration of different programming languages. Motion control operations, such as servo loops, should be polled and updated on a more immediate basis than auxiliary I/O or the operator interface. The programmer must develop this polling hierarchy to thread the system together.

Integrated controllers

A more integrated approach to machine control uses a stand-alone architecture that builds in the same essential elements of I/O, motion, operator interface, and communication. This approach uses a single software and hardware platform to control an entire machine application. The polling of servo loops, I/O points, and the operator interface are handled internally, invisible to the user. A common software language is provided to integrate the motion and I/O actuation. This pre-tested approach allows a typical machine control application to be developed with a minimum of effort and cost. The total application cost is the major consideration when selecting an integrated machine controller. While the initial hardware cost is typically higher than other solutions, the software investment and maintenance of a single language is an overriding and positive factor. Software development and maintenance costs for any machine control application can dwarf the initial hardware expense. The integrated approach offers a more economical solution.

Control System Overview

The controller is an essential part of any motion control system. It determines speed, direction, distance and acceleration rate – in fact all the parameters associated with the operation that the motor performs. The output from the controller is connected to the drive's input, either in the form of an analog voltage or as step and direction signals. In addition to controlling one or more motors, many controllers have additional inputs and outputs that allow them to monitor other functions on a machine (see Machine Control, p. A45).

Controllers can take a wide variety of forms. Some examples are listed below.

Standalone – This type of controller operates without data or other control signals from external sources. A standalone unit usually incorporates a keypad for data entry as well as a display, and frequently includes a main power supply. It will also include some form of nonvolatile memory to allow it to store a sequence of operations. Many controllers that need to be programmed from a terminal or computer can, once programmed, also operate in standalone mode.

Bus-based – A bus-based controller is designed to accept data from a host computer using a standard communications bus. Typical bus systems include STD, VME and IBM-PC bus. The controller will usually be a plug-in card that conforms to the standards for the corresponding bus system. For example, a controller operating on the IBM-PC bus resides within the PC, plugging into an expansion slot and functioning as an intelligent peripheral.

PLC-based – A PLC-based indexer is designed to accept data from a PLC in the form of I/O communication. Typically, the I/O information is in BCD format. The BCD information may select a program to execute, a distance to move, a time delay, or any other parameter requiring a number. The PLC is well suited to I/O actuation, but poorly suited to perform complex operations such as math and complicated decision making. The motion control functions are separated from the PLC's processor and thus do not burden its scan time.

X Code-based – X Code is a command language specifically developed for motion control and intended for transmission along an RS-232C link. Controllers using this language either accept real-time commands from a host computer or execute stored sequences that have been previously programmed. The simplicity of RS-232C communication allows the controller to be incorporated into the drive itself, resulting in an integrated indexer/drive package.

X Code Programming

X Code has been designed to allow motion control equipment to be programmed by users with little or no computer experience. Although the language includes more than 150 commands, depending on the product, it is only necessary to learn a small percentage of these to write simple programs.

Most command codes use the initial letter of the function name, which makes them easy to remember. Here are some examples of frequently used commands.

- V – velocity in revs/sec
- D – distance in steps
- A – acceleration rate in revs/sec²
- G – go; start the move
- T – time delay in seconds

A typical command string might look like this:

```
V10 A50 D4000 G T2 G
```

This would set the velocity to 10 revs/sec, acceleration to 50 revs/sec² and distance to 4000 steps. The 4000-step move would be performed twice with a 2-second wait between moves.

Please refer to specifications of X Code products for a list of all the available X Code commands.

Single-axis and Multi-axis Controllers

A single-axis controller can, as the name implies, only control one motor. The controller in an integrated indexer/drive comes into this category. However, such units are frequently used in systems using more than one motor where the operations do not involve precise synchronization between axes.

A multi-axis controller is designed to control more than one motor and can very often perform complex operations such as linear or circular interpolation. These operations require accurate synchronization between axes, which is generally easier to achieve with a central controller.

A variant of the multi-axis controller is the multiplexed unit, which can control several motors on a time-shared basis. A printing machine having the machine settings controlled by stepper motors could conveniently use this type of controller when the motors do not need to be moved simultaneously.

Hardware-based Controllers

Control systems designed without the use of a microprocessor have been around for many years and can be very cost-effective in simpler applications. They tend to lack flexibility and are therefore inappropriate where the move parameters are continually changing. For this reason, the hardware-based controller has now given way almost exclusively to systems based on a microprocessor.

Fig. 5.2 Processor-based controller

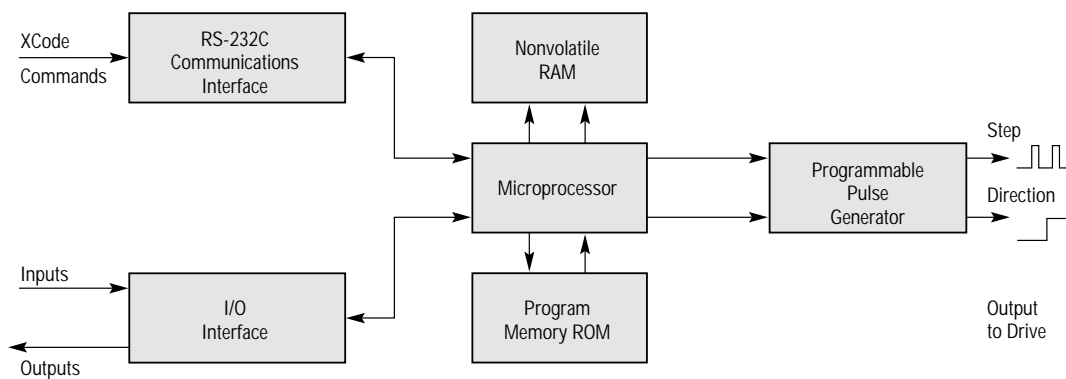

Processor-based Controllers

The flexibility offered by a microprocessor system makes it a natural choice for motion control. Fig. 5.2 shows the elements of a typical step and direction controller that can operate either in conjunction with a host computer or as a stand-alone unit.

All the control functions are handled by the microprocessor whose operating program is stored in ROM. This program will include an interpreter for the command language, which may be X Code for example.

X Code commands are received from the host computer or terminal via the RS-232C communications interface. These commands are simple statements that contain the required speed, distance and acceleration rate, etc. The processor interprets these commands and uses the information to control the programmable pulse generator. This in turn produces the step and direction signals that will control a stepper or servo drive.

The processor can also switch outputs and interrogate inputs via the I/O interface. Outputs can initiate other machine functions such as punching or cutting, or simply activate drive panel indicators to show the program status. Inputs may come from sources such as operator pushbuttons or directional limit switches.

When the controller is used in a standalone mode, the required motion sequences are programmed from the host and stored in nonvolatile memory (normally battery-backed RAM). These sequences may then be selected and executed from switches via the I/O interface or from a separate machine controller such as a PLC.

Understanding Input and Output Modules

Most motion controllers/indexers offer programmable inputs and outputs to control and interact with other external devices and machine elements.

Programmable Output Example

After indexing a table to a preset position, energize a programmable output to activate a knife that will cut material on the table.

Programmable Input Example

After indexing a table in a pick and place application, the indexer waits for an input signal from a robot arm, signaling the indexer that a part has been located on the table.

The primary reason for using I/O modules is to interface 5VDC logic signals from an indexer to switches and relays on the factory floor, which typically run on voltage levels ranging from 24VDC to 220VAC. Solid-state I/O modules are essentially a relay, utilizing light emitting diode (LED) and a transistor along with a signal conditioning circuit to activate a switch. These I/O modules isolate (no direct connection) the internal microprocessor circuitry of an indexer from oversized DC and AC voltages. The lack of a physical connection between the indexer and external devices, protects the indexer from hazardous voltage spikes and current surges.

DC Input and Output Modules

As with all DC devices, this is a polarized, + and - input module. Since current will flow in only one direction, care must be taken to observe these polarities during installation.

DC input modules typically feature an input signal conditioning circuit. This circuit requires the input to remain on/off for a minimum of 5 milliseconds

before recognizing the switch. This eliminates a short voltage spike or "de-bounce" contact closure less than 5 milliseconds in duration. However, a 0.1 microfarad, ceramic disc capacitor across the actual switching contacts is still recommended to prevent switch bounce that can be as long as 10-80 milliseconds.

Fig. 5.3 Typical DC input connection diagram

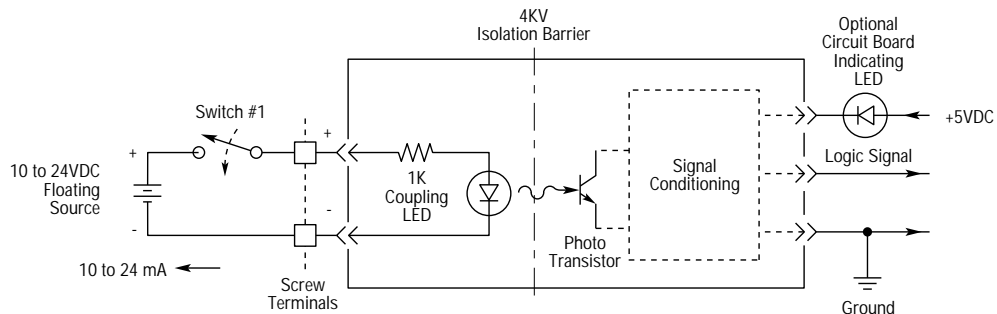

DC Input Operational Sequence

As switch #1 closes, current flows through the limiting resistor (1K ohm), and then into the LED. The light issued by the LED due to this forward current flow in turn simulates the photo transistor. Hence the term "opto" or optically isolated. The phototransistor then drives the base of the second transistor to a high level, bringing its output, or collector, to a low level.

The operation of the DC output model is similar to the DC input module. A 5VDC signal from an indexer is used to activate an LED. The output of the module is defined as open collector.

Fig. 5.4 represents a typical DC output schematic. Note the diode across the relay coil. These should always be installed to eliminate the leading inductive kick caused by the relay. A typical part number for such a diode is 1N4004. Failure to provide this protection can cause noise problems or the destruction of the output device.

Fig. 5.4 Typical DC output connection diagram

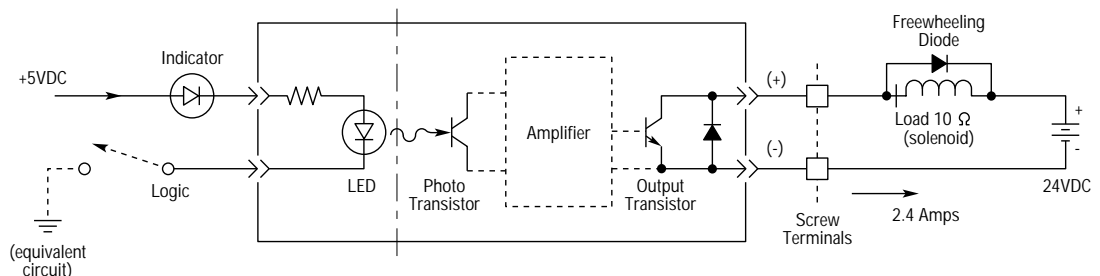

AC Input and Output Modules

AC modules are not polarized devices. This makes it virtually impossible to install a unit backwards.

AC input modules operate like DC input modules with the addition of a bridge rectifier to change AC

voltage to DC levels. AC input modules also include transient protection to filter out spikes from the AC line (caused by lightning strikes, arc welders, etc.).

Fig. 5.5 Typical AC input connection diagram

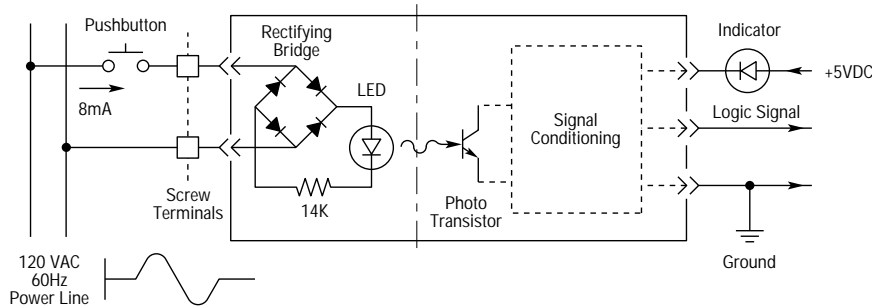

AC output modules feature a Triac power device as its output. A Triac output offers three distinct advantages.

1. Zero voltage turn on eliminates in-rush currents to the load.
2. Zero voltage turn off eliminates inductive kick problems.
3. A snubber across the output.

Fig. 5.6 Zero voltage turn on and off

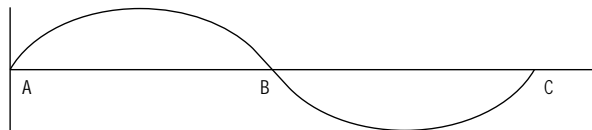

The module will only turn on or off at points A, B, or C; where the voltage is zero.

AC output modules do have leakage current, which may "turn-on" small current loads. To solve

potential problems, add a parallel resistor across the load, 5K, 5W for 120VAC and a 10K, 10W for 240VAC.

Fig. 5.7 Typical AC output connection diagram

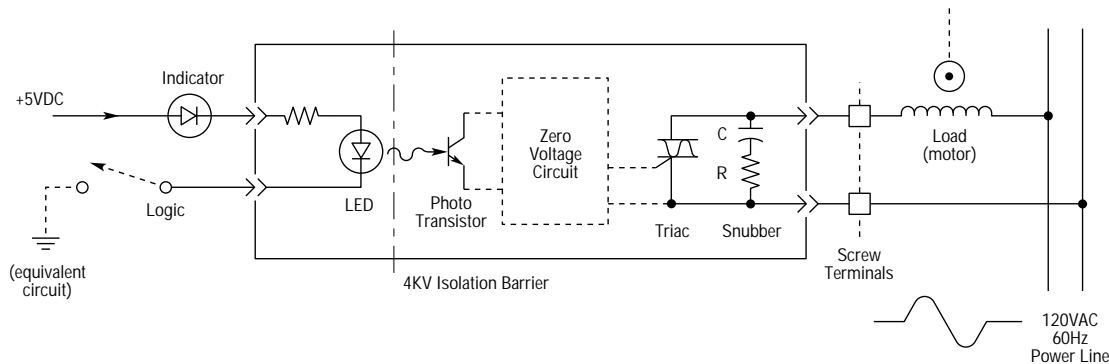

Serial and Parallel Communications

Serial and parallel communications are methods of transferring data from a host computer to a peripheral device such as a Compumotor indexer. In the case of a Compumotor indexer, the data consist of parameters such as acceleration,

Fig. 5.8 Serial Communications

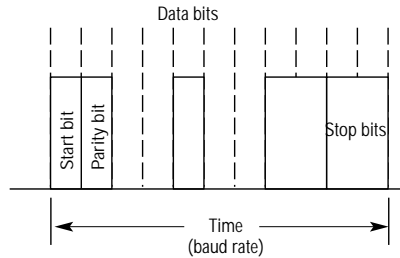

Serial

Serial communication transmits data one bit at a time on a single data line. Single data bits are grouped together into a byte and transmitted at a predetermined interval (baud rate). Serial communication links can be as simple as a 3-line connection; transmit (Tx), receive (Rx) and ground (G). This is an advantage from a cost standpoint, but usually results in slower communications than parallel communications. Common serial interfaces include RS-232C, RS-422, RS-485, RS-423.

Troubleshooting

Procedure for troubleshooting 3-wire RS-232C communication.

1. Verify that the transmit of the host is wired to the receive of the peripheral, and receive of the host is wired to the transmit of the peripheral. Note: *Try switching the receive and transmit wires on either the host or peripheral if you fail to get any communication.*
2. Some serial ports require handshaking. You can establish 3-wire communication by jumpering RTS to CTS (usually pins 4 and 5) and DSR to DTR (usually pins 6 and 20).
3. Configure the host and peripheral to the same baud rate, number of data bits, number of stop bits, and parity.
4. If you receive double characters (e.g., typing "A" and receiving "AA"), your computer is set to half duplex mode. Change to full duplex mode.
5. Use DC common or signal ground as your reference, NOT earth ground.
6. Cable lengths should not exceed 50 ft. unless you are using some form of line driver, optical coupler, or shield. As with any control signal, be sure to shield the cable to earth ground at one end only.
7. To test terminal or terminal emulation software for proper 3-wire communication, unhook the peripheral device and transmit a character. An echoed character should not be received. If a character is received, you are in half duplex mode. Jumper the host's transmit and receive lines and send another character. You should receive the echoed character. If not, consult the manufacturer of the host's serial interface for proper pin outs.

velocity, move distance, and move direction configured in ASCII characters. Both communication techniques are generally bi-directional allowing the host to both transmit and receive information from a peripheral device.

Fig. 5.9 Parallel Communications

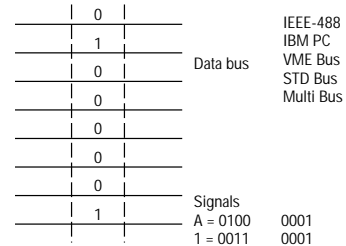

Parallel

Parallel communication requires handshaking and transmits data one byte (8 bits) at a time. When data are transferred from the host processor to a peripheral device, the following steps take place.

1. The host sets a bit on the bus signalling to the peripheral that a byte of data has been sent.
2. The peripheral receives data and sets a bit on the bus, signalling to the host that data have been received.

The advantage of communicating in parallel vs. serial is faster communications. However, since parallel communications require more communication lines, the cost can be higher than serial communications.

Parallel bus structures include:

IEEE-488, IBM PC, VME, MULTIBUS, Q and STD.

Troubleshooting

Procedure for troubleshooting parallel communication.

1. Make certain the address setting of the peripheral device is configured properly.
2. Confirm that multiple boards are not set to the same address (and each board is sealed properly into a slot).
3. Verify that peripheral subroutines to reset the board, write data, and read data work properly. Follow the handshaking procedure outlined in the device's user manual.

Note: Compumotor bus-based indexers come complete with a diskette that includes pretested programs to verify system functions and routines for simple user program development.

Serial and Parallel Communications

ADDRESS: Multiple devices are controlled on the same bus, each with a separate address or unit number. This address allows the host to communicate individually to each device.

ASCII: American Standard Code for Information Interchange. This code assigns a number to each numeral and letter of the alphabet. In this manner, information can be transmitted between machines as a series of binary numbers.

BAUD RATE: Number of bits transmitted per second. Typical rates include 300; 600; 1,200; 2,400; 4,800; 9,600, 19,200. This means at 9,600 baud, 1 character can be sent nearly every millisecond.

DATA BITS: Since the ASCII set consists of 128 characters, computers may transmit only 7 bits of data. Most computers do, however, support an 8-bit extended ASCII character set.

DCE: Data Communications Equipment transmits on pin 3 and receives on pin 2.

DTE: Data Terminal Equipment. Transmits on pin 2 and receives on pin 3.

FULL DUPLEX: The terminal will display only received or echoed characters.

HALF DUPLEX: In half duplex mode, a terminal will display every character transmitted. It may also display the received character.

HANDSHAKING SIGNALS:

RTS: Request To Send DTR: Data Terminal Ready
CTS: Clear To Send IDB: Input Data Buffer
DSR: Data Set Ready ODB: Output Data Buffer

NULL MODEM: A simple device or set of connectors that switches the receive and transmit lines a 3-wire RS-232C connector.

PARITY: An RS-232C error detection scheme that can detect an odd number of transmission errors.

SERIAL POLLING: Method of checking the status of the IEEE-488 device. By reading the status byte, the host can determine if the device is ready to receive or send characters.

START BITS: When using RS-232C, one or two bits are added to every character to signal the end of a character.

TEXT/ECHO (ON/OFF): This setup allows received characters to be re-transmitted back to the original sending device. Echoing characters can be used to verify or "close the loop" on a transmission.

XON/XOFF: Two ASCII characters supported in some serial communication programs. If supported, the receiving device transmits an XOFF character to the host when its character buffer is full. The XOFF character directs the host to stop transmitting characters to the device. Once the buffer empties, the device will transmit an XON character to signal the host to resume transmission.

ASCII Table

DEC	HEX	GRAPHIC	DEC	HEX	GRAPHIC	DEC	HEX	GRAPHIC	DEC	HEX	GRAPHIC	DEC	HEX	GRAPHIC
000	00	NUL	030	1E	RS	059	3B	;	088	58	X	117	75	u
001	01	SOH	031	1F	US	060	3C	<	089	59	Y	118	76	v
002	02	STX	032	20	SPACE	061	3D	=	090	5A	Z	119	77	w
003	03	ETX	033	21	!	062	3E	>	091	5B	[120	78	x
004	04	EOT	034	22	"	063	3F	?	092	5C	/	121	79	y
005	05	ENQ	035	23	#	064	40	@	093	5D]	122	7A	z
006	06	ACK	036	24	\$	065	41	A	094	5E	V	123	7B	{
007	07	BEL	037	25	%	066	42	B	095	5F	-	124	7C	
008	08	BS	038	26	&	067	43	C	096	60	'	125	7D	}
009	09	HT	039	27	'	068	44	D	097	61	a	126	7E	~
010	0A	LF	040	28	(069	45	E	098	62	b	127	7F	DEL
011	0B	VT	041	29)	070	46	F	099	63	c			
012	0C	FF	042	2A	*	071	47	G	100	64	d			
013	0D	CR	043	2B	+	072	48	H	101	65	e			
014	0E	SO	044	2C	,	073	49	I	102	66	f			
015	0F	S1	045	2D	-	074	4A	J	103	67	g			
016	10	DLE	046	2E	.	074	4B	K	104	68	h			
017	11	DC1	047	2F	/	075	4C	L	105	69	i			
018	12	DC2	048	30	0	076	4D	M	106	6A	j			
019	13	DC3	049	31	1	077	4E	N	107	6B	k			
020	14	DC4	050	32	2	078	4F	O	108	6C	l			
021	15	NAK	051	33	3	080	50	P	109	6D	m			
022	16	SYN	052	34	4	081	51	Q	110	6E	n			
023	17	ETB	053	35	5	082	52	R	111	6F	o			
024	18	CAN	054	36	6	083	53	S	112	70	p			
025	19	EM	055	37	7	084	54	T	113	71	q			
026	1A	SUB	056	38	8	085	55	U	114	72	r			
027	1B	ESC	057	39	9	086	56	V	115	73	s			
028	1C	FS	058	3A	:	087	57	W	116	74	t			

Electrical Noise . . . Sources, Symptoms and Solutions

Noise related difficulties can range in severity from minor positioning errors to damaged equipment from runaway motors crashing blindly through limit switches. In microprocessor controlled equipment, the processor is constantly retrieving instructions from memory in a controlled sequence. If an electrical disturbance occurs, it could cause the processor to misinterpret an instruction, or access the wrong data. This is likely to be catastrophic to the program, requiring a processor reset. Most Compumotor indexers are designed with a watchdog timer that shuts down the system if the program is interrupted. This prevents the more catastrophic failures.

Sources of Noise

Being invisible, electrical noise can be very mysterious, but it invariably comes from the following sources:

- Power line disturbances
- Externally conducted noise
- Transmitted noise
- Ground loops

Some common electrical devices generate electrical noise.

- Coil driven devices: conducted and power line noise
- SCR-fired heaters: transmitted and power line noise
- Motors and motor drives: transmitted and power line noise
- Welders (electric): transmitted and power line noise

Power line disturbances are usually easy to solve due to the wide availability of line filtering equipment for the industry. Only the most severe situations call for an isolation transformer. Line filtering equipment is required when other devices connected to the local power line are switching large amounts of current, especially if the switching takes place at high frequency. Corcom and Teal are two manufacturers of suitable power line filters.

Also, any device having coils is likely to upset the line when it is switched off. Surge suppressors such as MOVs (General Electric) can limit this kind of noise. A series RC network across the coil is also effective, (resistance; 500 to 1,000 Ω , capacitance; 0.1 to 0.2 μ F). Coil-driven devices (inductive loads) include relays, solenoids, contactors, clutches, brakes and motor starters.

Fig. 5.10 Typical RC Network

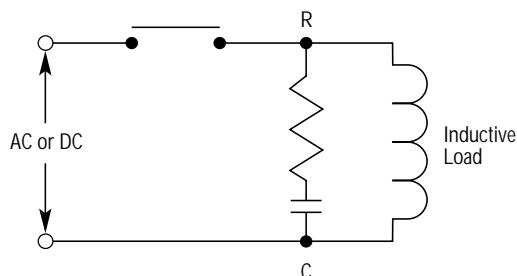

Externally Conducted Noise

Externally conducted noise is similar to power line noise, but the disturbances are created on signal and ground wires connected to the indexer. This kind of noise can get onto logic circuit ground or into the processor power supply and scramble the program. The problem here is that control equipment often shares a common DC ground that may run to several devices, such as a DC power supply, programmable controller, remote switches and the like. When some noisy device, particularly a relay or solenoid, is on the DC ground, it may cause disturbances within the indexer.

The solution for DC mechanical relays and solenoids involves connecting a diode backwards across the coil to clamp the induced voltage "kick" that the coil will produce. The diode should be rated at 4 times the coil voltage and 10 times the coil current. Using *solid-state relays* eliminates this effect altogether.

Fig. 5.11 Coil Suppression Methods

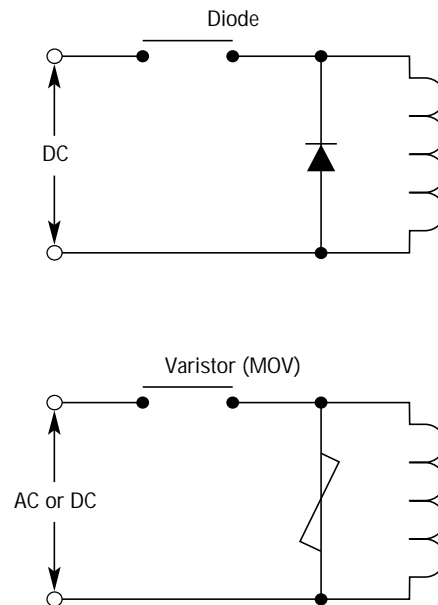

Multiple devices on the same circuit should be grounded together at a single point.

Furthermore, power supplies and programmable controllers often have DC common tied to Earth (AC power ground). As a rule, it is preferable to have indexer signal ground or DC common floating with respect to Earth. This prevents noisy equipment that is grounded to Earth from sending noise into the indexer. The Earth ground connection should be made at one point only as discussed in "Ground Loops" on p. A53.

In many cases, optical isolation may be required to completely eliminate electrical contact between the indexer and a noisy environment. Solid-state relays provide this isolation.

Transmitted Noise

Transmitted noise is picked up by external connections to the indexer, and in severe cases, can attack an indexer with no external connections. The indexer enclosure will typically shield the electronics from this, but openings in the enclosure for connection and front panel controls may "leak". As with all electrical equipment, the indexer chassis should be scrupulously connected to Earth to minimize this effect.

When high current contacts open, they draw an arc, producing a burst of broad spectrum radio frequency noise that can be picked up on an indexer limit switch or other wiring. High current and high voltage wires have an electrical field around them, and may induce noise on signal wiring (especially when they are tied in the same wiring bundle or conduit).

When this kind of problem occurs, consider shielding signal cables or isolating the signals. A proper shield surrounds the signal wires to intercept electrical fields, but this shield must be tied to Earth to drain the induced voltages. At the very least, wires should be run in twisted pairs to limit straight line antenna effects.

Most Compumotor cables have shields tied to Earth, but in some cases the shields must be grounded at installation time. Installing the indexer in a NEMA electrical enclosure ensures protection from this kind of noise, unless noise-producing equipment is also mounted inside the enclosure. Connections external to the enclosure must be shielded.

Even the worst noise problems, in environments near 600 amp welders and 25kW transmitters, have been solved using enclosures, conduit, optical isolation, and single-point ground techniques.

Ground Loops

Ground Loops create the most mysterious noise problems. They seem to occur most often in systems where a control computer is using RS-232C communication. Garbled transmission and intermittent operation symptoms are typical.

The problem occurs in systems where multiple Earth ground connections exist, particularly when these connections are far apart.

Example

Suppose a Model 500 is controlling an axis, and the limit switches use an external power supply. The Model 500 is controlled by a computer in another room. If the power supply Common is connected to Earth, ground loop problems may occur (most computers have their RS-232C signal common tied to Earth). The loop starts at the Model 500's limit switch ground, goes to Earth through the power supply to Earth at the computer. From there, the loop returns to the Model 500 through RS-232C signal ground. If a voltage potential exists between power supply Earth and remote computer Earth, ground, current will flow through the RS-232C ground creating unpredictable results.

The way to test for and ultimately eliminate a ground loop is to lift or "cheat" Earth ground connections in the system until the symptoms disappear.

Defeating Noise

The best time to handle electrical noise problems is before they occur. When a motion system is in the design process, the designer should consider the following system wiring guidelines (listed by order of importance).

1. Put surge suppression components on all electrical coils: resistor/capacitor filters, MOVs, Zener and clamping diodes.
2. Shield all remote connections and use twisted pairs. Shields should be tied to Earth at one end.
3. Put all microelectronic components in an enclosure. Keep noisy devices outside. Monitor internal temperature.
4. Ground signal common wiring at one point. Float this ground from Earth if possible.
5. Tie all mechanical grounds to Earth at one point. Run chassis and motor grounds to the frame, frame to Earth.
6. Isolate remote signals. Solid-state relays or opto isolators are recommended.
7. Filter the power line. Use common RF filters (isolation transformer for worst-case situations).

A noise problem must be identified before it can be solved. The obvious way to approach a problem situation is to eliminate potential noise sources until the symptoms disappear, as in the case of ground loops. When this is not practical, use the above guidelines to troubleshoot the installation.

References

Information about the equipment referred to may be obtained by calling the numbers listed below.

- Corcom line filters (312) 680-7400
- Opto-22 optically isolated relays (714) 891-5861
- Crydom optically isolated relays (213) 322-4987
- Potter Brumfield optically isolated relays (812) 386-1000
- General Electric MOVs (315) 456-3266
- Teal power line isolation filters (800) 888-8325

Stopping in an Emergency

For safety reasons, it is often necessary to incorporate some form of emergency stop system into machinery fitted with stepper or servo motors. There are several reasons for needing to stop quickly.

- To prevent injury to the operator if he makes a mistake or operates the machinery improperly.
- To prevent damage to the machine or to the product as a result of a jam.
- To guard against machine faults. You should consider all the possible reasons for stopping to make sure that they are adequately covered.

How should you stop the system?

There are several ways to bring a motor to a rapid stop. The choice depends partly on whether it is more important to stop in the shortest possible time or to guarantee a stop under all circumstances. For instance, to stop as quickly as possible means using the decelerating power of the servo system. However, if the servo has failed or control has been lost, this may not be an option open to you. In this case, removing the power will guarantee that the motor stops; but if the load has a high inertia, this may take some time. If the load is moving vertically and can back-drive the motor, this introduces additional complications. In extreme cases where personal safety is at risk, it may be necessary to mechanically lock the system even at the expense of possible damage to the machine.

Emergency Stop Methods

1. Full-torque controlled stop.

Applying zero velocity command to a servo amplifier will cause it to decelerate hard to zero speed in current limit, in other words, using the maximum available torque. This will create the fastest possible deceleration to rest. In the case of a digital servo with step and direction inputs, cutting off the step pulses will produce the same effect.

The situation is different for a stepper drive. The step pulse train should be decelerated to zero speed to utilize the available torque. Simply cutting off the step pulses at speeds above the start-stop rate will de-synchronize the motor and the full decelerating torque will no longer be available. The controller needs to be able to generate a rapid deceleration rate independent of the normal programmed rate, to be used only for overtravel limit and emergency stop functions.

2. Disconnect the motor.

Although this method is undoubtedly safe, it is not highly recommended as a quick-stop measure. The time taken to stop is indeterminate, since it depends on load inertia and friction, and in high-performance systems the friction is usually kept to a minimum. Certain types of drives may be damaged by disconnecting the motor under power. This method is particularly unsatisfactory in the case of a vertical axis, since the load may fall under gravity.

3. Remove the AC input power from the drive.

On drives that incorporate a power dump circuit, a degree of dynamic braking is usually provided when the power is removed. This is a better solution than disconnecting the motor, although the power supply capacitors may take some time to decay and this will extend the stopping distance.

4. Use dynamic braking.

A motor with permanent magnets will act as a generator when driven mechanically. By applying a resistive load to the motor, a braking effect is produced that is speed-dependent. Deceleration is therefore rapid at high speeds, but falls off as the motor slows down.

A changeover contactor can be arranged to switch the motor connections from the drive to the resistive load. This can be made failsafe by ensuring that braking occurs if the power supply fails. The optimum resistor value depends on the motor, but will typically lie in the 1-3 ohms range. It must be chosen to avoid the risk of demagnetization at maximum speed as well as possible mechanical damage through excessive torque.

5. Use a mechanical brake.

It is very often possible to fit a mechanical brake either directly on the motor or on some other part of the mechanism. However, such brakes are usually intended to prevent movement at power-down and are seldom adequate to bring the system to a rapid halt, particularly if the drive is delivering full current at the time. Brakes can introduce friction even when released, and also add inertia to the system – both effects will increase the drive power requirements.

What is the best stopping method?

It is clear that each of the methods outlined above has certain advantages and drawbacks. This leads to the conclusion that the best solution is to use a combination of techniques, ideally incorporating a short time delay.

We can make use of the fact that a contactor used for dynamic braking will take a finite time to drop out, so it is possible to de-energize the contactor coil while commanding zero speed to the drive. This allows for a controlled stop to occur under full torque, with the backup of dynamic braking in the event that the amplifier or controller has failed.

WARNING! – *there is a risk that decelerating a servo to rest in full current limit could result in mechanical damage, especially if a high-ratio gearbox is used.* This does not necessarily ensure a safe stop, be sure that the mechanism can withstand this treatment.

A mechanical brake should also be applied to a vertical axis to prevent subsequent movement. An alternative to the electrically-operated brake is the differential drag brake, which will prevent the load from falling but creates negligible torque in the opposite direction.

Application Considerations

Accuracy

An accuracy specification defines the maximum error in achieving a desired position. Some types of accuracy are affected by the application. For example, repeatability will change with the friction and inertia of the system the motor is driving.

Accuracy in a rotary motor is usually defined in terms of arcminutes or arcseconds (the terms

arcsecond and arcminute are equivalent to second and minute, respectively). There are 1,296,000 seconds of arc in a circle. For example, an arcsecond represents 0.00291 inches of movement on a circle with a 50-foot radius. This is equivalent to about the width of a human hair.

Stepper Accuracy

There are several types of performance listed under Compumotor's motor specifications: repeatability, accuracy, relative accuracy, and hysteresis.

Repeatability

The motor's ability to return to the same position from the same direction. Usually tested by moving the motor one revolution, it also applies to linear step motors moving to the same place from the same direction. This measurement is made with the motor unloaded, so that bearing friction is the prominent load factor. It is also necessary to ensure the motor is moving to the repeat position from a distance of at least one motor pole. This compensates for the motor's hysteresis. A motor pole in a Compumotor is 1/50 of a revolution.

Accuracy

Also referred to as absolute accuracy, this specification defines the quality of the motor's mechanical construction. The error cancels itself over 360° of rotation, and is typically distributed in a sinusoidal fashion. This means the error will gradually increase, decrease to zero, increase in the opposite direction and finally decrease again upon reaching 360° of rotation. Absolute accuracy causes the size of microsteps to vary somewhat because the full motor steps that must be traversed by a fixed number of microsteps varies. The steps can be over or undersized by about 4.5% as a result of absolute accuracy errors.

Relative Accuracy

Also referred to as step-to-step accuracy, this specification tells how microsteps can change in size. In a perfect system, microsteps would all be exactly the same size, but drive characteristics and the absolute accuracy of the motor cause the steps to expand and contract by an amount up to the relative accuracy figure. The error is not cumulative.

Hysteresis

The motor's tendency to resist a change in direction. This is a magnetic characteristic of the motor, it is not due to friction or other external factors. The motor must develop torque to overcome hysteresis when it reverses direction. In reversing direction, a one revolution move will show hysteresis by moving the full distance less the hysteresis figure.

Servo & Closed-Loop Stepper Accuracy

Repeatability, accuracy and relative accuracy in servos and closed-loop stepper systems relate as much to their feedback mechanisms as they do to the inherent characteristics of the motor and drive.

Servos

Compumotor servos use resolver feedback to determine their resolution and position. It is essentially the resolution of the device reading the resolver position that determines the highest possible accuracy in the system. Digiplan servos use encoder feedback to determine their resolution and position. In this case, it is the encoder's resolution that determines the system's accuracy. The positional accuracy is determined by the drive's ability to move the motor to the position indicated by the resolver or encoder. Changes in friction or inertial loading will adversely affect the accuracy until the system is properly tuned.

Closed-Loop Steppers

Compumotor closed-loop stepper systems use an encoder to provide feedback for the control loop. The encoder resolution determines the system's accuracy. When enabled, the controlling indexer attempts to position the motor within the specified deadband from the encoder. Typically, this means the motor will be positioned to within one encoder step. To do this satisfactorily, the motor must have more resolution than the encoder. If the step size of the motor is equal to or larger than the step size of the encoder, the motor will be unable to maintain a position and may become unstable. In a system with adequate motor-to-encoder resolution, the motor is able to maintain one encoder step of accuracy with great dependability. This is a continuous process that will respond to outside events that disturb the motor's position.

Application Considerations

Load characteristics, performance requirements, and coupling techniques need to be understood before the designer can select the best motor/drive for the job. While not a difficult process, several factors need to be considered for an optimum solution. A good designer will adjust the characteristics of the elements under his control – including the motor/drive and the mechanical transmission type (gears, lead screws, etc.) – to meet the performance requirements. Some important parameters are listed below.

Torque

Rotational force (ounce-inches) defined as a linear force (ounces) multiplied by a radius (inches). When selecting a motor/drive, the torque capacity of the motor must exceed the load. The torque any motor can provide varies with its speed. Individual speed/torque curves should be consulted by the designer for each application.

Inertia

An object's inertia is a measure of its resistance to change in velocity. The larger the inertial load, the longer it takes a motor to accelerate or decelerate that load. However, the speed at which a motor rotates is independent of inertia. For rotary motion, inertia is proportional to the mass of the object being moved times the square of its distance from the axis of rotation.

Friction

All mechanical systems exhibit some frictional force, and this should be taken into account when sizing the motor, as the motor must provide torque to overcome any system friction. A small amount of friction is desirable since it can reduce settling time and improve performance.

Torque-to-Inertia Ratio

This number is defined as a motor's rated torque divided by its rotor inertia. This ratio is a measure of how quickly a motor can accelerate and decelerate its own mass. Motors with similar ratings can have different torque-to-inertia ratios as a result of varying construction.

Load Inertia-to-Rotor Inertia Ratio

For a high performance, relatively fast system, load inertia reflected to the motor should generally not exceed the motor inertia by more than 10 times. Load inertias in excess of 10 times the rotor inertia can cause unstable system behavior.

Torque Margin

Whenever possible, a motor/drive that can provide more motor torque than the application requires should be specified. This torque margin accommodates mechanical wear, lubricant hardening, and other unexpected friction. Resonance effects, while dramatically reduced with the Compumotor microstepping system, can cause the motor's torque to be slightly reduced at some speeds. Selecting a motor/drive that provides at least 50% margin above the minimum needed torque is good practice.

Velocity

Because available torque varies with velocity, motor/drives must be selected with the required torque at the velocities needed by the application. In some cases, a change in the type of mechanical transmission used is needed to achieve the required performance.

Resolution

The positioning resolution required by the application will have an effect on the type of transmission used and the motor resolution. For instance, a leadscrew with 4 revolutions per inch and a 25,000-step-per-revolution motor/drive would give 100,000 steps per inch. Each step would then be 0.00001 inches.

Duty Cycle

Some motor/drives can produce peak torque for short time intervals as long as the RMS or average torque is within the motor's continuous duty rating. To take advantage of this feature, the application torque requirements over various time intervals need to be examined so RMS torque can be calculated.

Solving Duty Cycle Limitation Problems

Operating a motor beyond its recommended duty cycle results in excessive heat in the motor and drive. The drive cycle may be increased by providing active cooling to the drive and the motor. A fan directed across the motor and another directed across the drive's heatsink will result in increased duty cycle capability.

In most cases, it is possible to tell if the duty cycle is being exceeded by measuring the temperature of the motor and drive. Refer to the specifications for individual components for their maximum allowable temperatures.

Note: Motors will run at case temperatures up to 100°C (212°F)—temperatures hot enough to burn individuals who touch the motors.

To Improve Duty Cycle:

- Mount the drive with heatsink fins running vertically
- Fan cool the motor
- Fan cool the drive
- Put the drive into REMOTE POWER SHUTDOWN when it isn't moving, or reduce current
- Reduce the peak current to the motor (if possible)
- Use a motor large enough for the application

A wide range of applications can be solved effectively by more than one motor type. However, some applications are particularly appropriate for each motor type. Compumotor's Motor Sizing and Selection Software package is designed to help you easily identify the proper motor size and type for your specific motion control application.

This software helps calculate load inertias and required torques—information that is reflected through a variety of machine transmissions and reductions, including leadscrews, gears, belts, and pulleys. This software then produces graphs of the results, allowing you to select the proper motor from a comprehensive, detailed database of more than 200 motor models.

IBM® PC-compatible, Motor Sizing & Selection software also generates a number of application-specific reports, including profiles and speed/

torque curves that are based on user-provided information. This advanced graphics package is VGA/EGA compatible and allows data entry with either a mouse or keypad.

Contact your local Automotive Technology Center to obtain a copy.

The screenshots illustrate the software's interface for configuring a lead screw transmission and selecting a motor. Key components include:

- Motor Types Dialog:** Allows selection of motor technology (Stepper, Brushless servo, Compumotor Plus, S-Drive, Brush servo, Dunaserv) and size (Size 23 or smaller, Size 34 or smaller, Size 42 or smaller, Larger than size 42).
- LeadScrew Transmission Dialog:** Configures units (Lead, Screw Diameter, Screw Length, Load Weight, Counterbalance, Thrust Load, BreakAway Torque, Friction Coefficient, Incline Angle, Screw Efficiency) and inertia (Diameter, Length, Weight, Density).
- Material Selection Dialog:** Lists materials such as Steel, Aluminum, Brass, Bronze, Copper, Plastic, Hard Wood, and Soft Wood.
- Summary Report:**

PARKER MOTOR SIZING AXIS SUMMARY
Version: 2.0
Copyright (c) 1991, Parker Hannifin
All rights reserved worldwide.
For Application Assistance call (800) 358-9070
Outside the United States call (707) 584-7558
Thu Jan 07 13:17:39 1993

Application: Leadscre1
Number of defined axes: 1
Report for axis: 1

Description:
Leadscrew axis with 50 lb load.
Velocity of 5 ips, distance at speed of 24 inches.

Description	Axis	Profile	Print Report	Page Up
Transmission	Reducer(s)	Motor(s)	Exit	Page Down

Summary: AXIS 1: Leadscrew

 - Profile - Velocity & distance
 - Transmission - Leadscrew
 - Reduction - No Reduction

Type	Move Time	Torque Margin	Inertia Ratio
S Microstepper	5.400	141.17%	4.89

System Calculations

Move Profile

Before calculating torque requirements of an application, you need to know the velocities and accelerations needed. For those positioning applications where only a distance (X) and a time (S) to move that distance are known, the trapezoidal motion profile and formulas given below are a good starting point for determining your requirements. If velocity and acceleration parameters are already known, you can proceed to one of the specific application examples on the following pages.

Move distance X in time S.

Assume that:

1. Distance X/4 is moved in time S/3 (Acceleration)
2. Distance X/2 is moved in time S/3 (Run)
3. Distance X/4 is moved in time S/3 (Deceleration)

The graph would appear as follows:

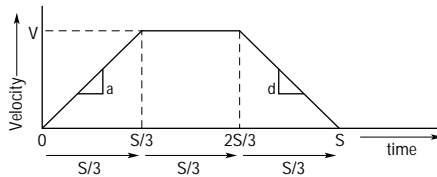

Common Move Profile Considerations

Distance: _____ Inches of Travel _____ revolutions of motor
 Move Time: _____ seconds
 Accuracy: _____ arcminutes, degrees or inches
 Repeatability: _____ arcseconds, degrees or inches
 Duty Cycle
 on time: _____ seconds
 off time: _____ seconds
 Cycle Rate: _____ sec. min. hour

The acceleration (a), velocity (v) and deceleration (d) may be calculated in terms of the knowns, X and S.

$$a = -d = \frac{2X}{t^2} = \frac{2\left(\frac{X}{4}\right)}{\left(\frac{S}{3}\right)^2} = \frac{X}{S^2} \cdot 9 = \frac{4.5X}{S^2}$$

$$v = at = \frac{4.5X}{S^2} \times \frac{S}{3} = \frac{1.5X}{S}$$

Example

You need to move 6" in 2 seconds

$$a = -d = \frac{4.5 (6 \text{ inches})}{(2 \text{ seconds})^2} = 6.75 \frac{\text{inches}}{\text{second}^2}$$

$$v = \frac{1.5 (6 \text{ inches})}{(2 \text{ seconds})} = 4.5 \frac{\text{inches}}{\text{second}}$$

Motor/Drive Selection

Based on Continuous Torque Requirements

Having calculated the torque requirements for an application, you can select the motor/drive suited to your needs. Microstepping motor systems (S Series, Zeta Series OEM650 Series, LN Series) have speed/torque curves based on continuous duty operation. To choose a motor, simply plot total torque vs. velocity on the speed/torque curve. This point should fall under the curve and allow approximately a 50% margin for safety. An S106-178 and an S83-135 curve are shown here.

Note: When selecting a ZETA Series product, a 50% torque margin is not required.

Example

Assume the following results from load calculations:

$T_F = 25 \text{ oz-in}$ Friction torque
 $T_A = 175 \text{ oz-in}$ Acceleration torque
 $T_T = 200 \text{ oz-in}$ Total torque
 $V = 15 \text{ rev/sec}$ Maximum velocity

You can see that the total torque at the required velocity falls within the motor/drive operating range for both motors by plotting T_T .

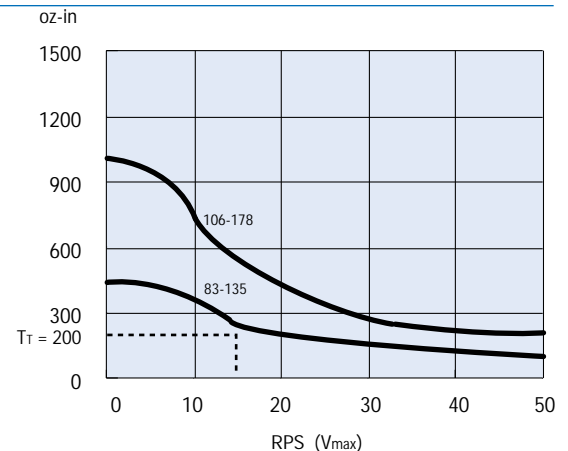

The S83-135 has approximately 250 oz-in available at V max (25% more than required). The S106-178 has 375 oz-in available, an 88% margin.

In this case, we would select the S106-178 motor/drive to assure a sufficient torque margin to allow for changing load conditions.

Motor/Drive Selection

Based on peak torque requirements
 Servo-based motor/drives have two speed/torque curves: one for continuous duty operation and another for intermittent duty. A servo system can be selected according to the total torque and maximum velocity indicated by the continuous duty curve. However, by calculating the root mean square (RMS) torque based on your duty cycle, you may be able to take advantage of the higher peak torque available in the intermittent duty range.

$$T_{RMS} = \sqrt{\frac{\sum T_i^2 t_i}{\sum t_i}}$$

Where:

- T_i is the torque required over the time interval t_i
- \sum means "the sum of"

Example

Assume the following results from your load calculations.

T_F	= 25 oz-in	Friction Torque
T_A	= 775 oz-in	Acceleration Torque
T_T	= 800 oz-in	Total Torque
V_{max}	= 20 rps	Maximum Velocity

Motion Profile

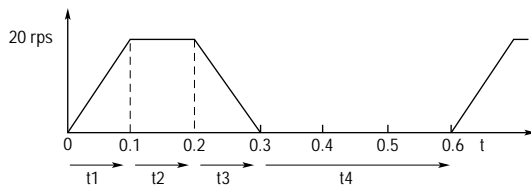

Duty Cycle

Index 4 revs in 0.3 seconds, dwell 0.3 seconds then repeat.

If you look at the S106-178 speed/torque curve, you'll see that the requirements fall outside the curve.

- T_1 = Torque required to accelerate the load from zero speed to maximum speed ($T_F + T_A$)
- T_2 = Torque required to keep the motor moving once it reaches max speed (T_F)
- T_3 = Torque required to decelerate from max speed to a stop ($T_A - T_F$)
- T_4 = Torque required while motor is sitting still at zero speed (\emptyset)
- t_1 = Time spent accelerating the load
- t_2 = Time spent while motor is turning at constant speed
- t_3 = Time spent decelerating the load
- t_4 = Time spent while motor is at rest

$$T_{RMS} = \sqrt{\frac{T_1^2 t_1 + T_2^2 t_2 + T_3^2 t_3 + T_4^2 t_4}{t_1 + t_2 + t_3 + t_4}}$$

$$= \sqrt{\frac{(800)^2(.1) + (25)^2(.1) + (750)^2(.1) + (0)^2(.3)}{(.1) + (.1) + (.1) + (.3)}}$$

$$T_{RMS} = 447 \text{ oz. in.}$$

Now plot T_{RMS} and T_T vs. T_{max} on the speed/torque curve.

The drawing below resembles the speed/torque curve for the Z606 motor.

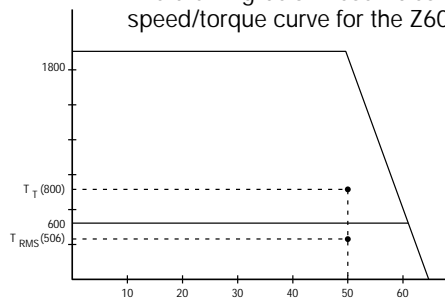

The Z606 motor will meet the requirements. RMS torque falls within the continuous duty cycle and total torque vs. velocity falls within the intermittent range.

How to Use a Step Motor Horsepower Curve

Horsepower (HP) gives an indication of the motor's top usable speed. The peak or "hump" in a horsepower curve indicates a speed that gives maximum power. Choosing a speed beyond the peak of the HP curve results in no more power: the power attained at higher speeds is also attainable at a lower speed. Unless the speed is required for the application, there is little benefit to going beyond the peak as motor wear is faster at higher speeds.

Applications requiring the most power the motor can generate, not the most torque, should use a motor speed that is *just* below the peak of the HP curve.

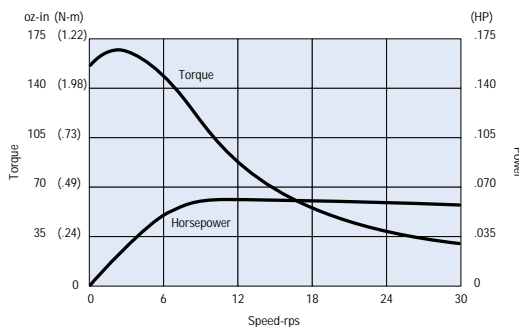

Leadscrew Drives

Leadscrews convert rotary motion to linear motion and come in a wide variety of configurations. Screws are available with different lengths, diameters, and thread pitches. Nuts range from the simple plastic variety to precision ground versions with recirculating ball bearings that can achieve very high accuracy.

The combination of microstepping and a quality leadscrew provides exceptional positioning resolution for many applications. A typical 10-pitch (10 threads per inch) screw attached to a 25,000 step/rev. motor provides a linear resolution of 0.000004" (4 millionths, or approximately 0.1 micron) per step.

A flexible coupling should be used between the leadscrew and the motor to provide some damping. The coupling will also prevent excessive motor bearing loading due to any misalignment.

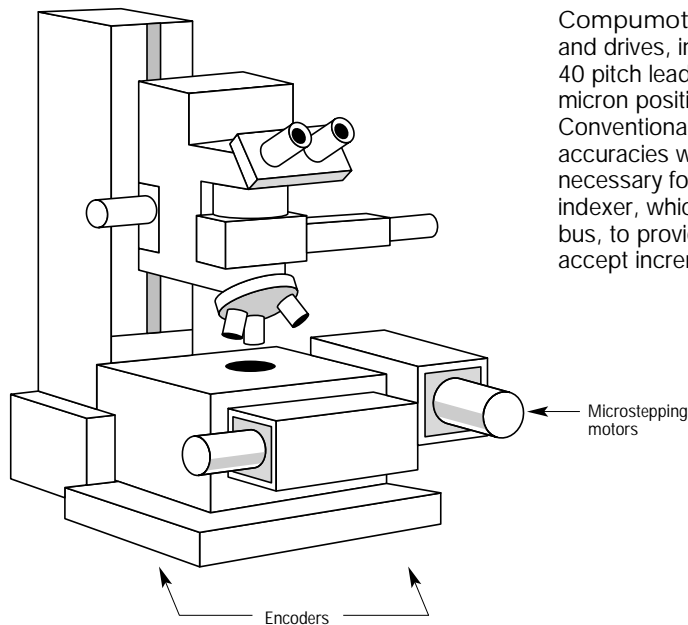

Microscope Positioning

Application Type: X/Y Point to Point

Motion: Linear

Description: A medical research lab needs to automate their visual inspection process. Each specimen has an origin imprinted on the slide with all other positions referenced from that point. The system uses a PC-AT Bus computer to reduce data input from the operator, and determines the next data point based on previous readings. Each data point must be accurate to within 0.1 microns.

Machine Objectives

- Sub-micron positioning
- Specimen to remain still during inspection
- Low-speed smoothness (delicate equipment)
- Use PC-AT Bus computer

Motion Control Requirements

- High resolution, linear encoders
- Stepper (zero speed stability)
- Microstepping
- PC-AT Bus controller

Compumotor Solution: Microstepping motors and drives, in conjunction with a precision ground 40 pitch leadscrew table, provide a means of sub-micron positioning with zero speed stability. Conventional mechanics cannot provide 0.1 micron accuracies without high grade linear encoders. It is necessary for the Compumotor Model AT6400 indexer, which resides directly on the computer bus, to provide full X, Y, Z microscope control and accept incremental encoder feedback.

Precision Grinder

A bearing manufacturer is replacing some equipment that finishes bearing races. The old equipment had a two-stage grinding arrangement where one motor and gearbox provided a rough cut and a second motor with a higher ratio gearbox performed the finishing cut. The designer would like to simplify the mechanics and eliminate one motor. He wants to use a single leadscrew and exploit the wide speed range available with microstepping to perform both cuts. This will be accomplished by moving a cutting tool mounted on the end of the leadscrew into the workpiece at two velocities; an initial velocity for the rough cut and a much reduced final velocity for the finish cut.

The torque required to accelerate the load and overcome the inertia of the load and the rotational inertia of the leadscrew is determined to be 120 oz-in. The torque necessary to overcome friction is measured with a torque wrench and found to be 40 oz-in. A microstepping motor with 290 oz-in of torque is selected and provides adequate torque margin.

This grinder is controlled by a programmable controller (PC) and the environment requires that the electronics withstand a 60°C environment. An indexer will provide the necessary velocities and accelerations. The speed change in the middle of the grinding operation will be signaled to the PC with a limit switch, and the PC will in turn program the new velocity into the indexer. Additionally, the indexer Stall Detect feature will be used in conjunction with an optical encoder mounted on the back of the motor to alert the PC if the mechanics become "stuck."

Other Leadscrew Drive Applications

- XY Plotters
- Facsimile transmission
- Tool bit positioning
- Cut-to-length machinery
- Back gauging
- Microscope drives
- Coil winders
- Slides
- Pick-and-Place machines
- Articulated arms

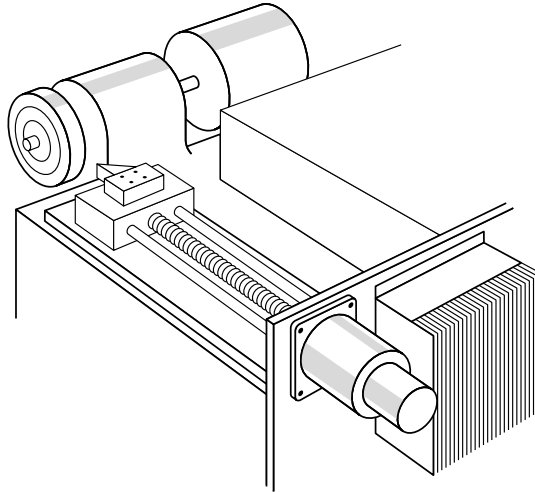

Leadscrew Application Data

Inertia of Leadscrews per Inch

Diameter				Diameter			
In.	Steel	Brass	Alum.	In.	Steel	Brass	Alum.
0.25	0.0017	0.0018	0.0006	2.75	25.1543	26.9510	8.6468
0.50	0.0275	0.0295	0.0094	3.00	35.6259	38.1707	12.2464
0.75	0.1392	0.1491	0.0478	3.25	49.0699	52.5749	16.8678
1.00	0.4398	0.4712	0.1512	3.50	66.0015	70.7159	22.6880
1.25	1.0738	1.1505	0.3691	3.75	86.9774	93.1901	29.8985
1.50	2.2266	2.3857	0.7654	4.00	112.5956	120.6381	38.7047
1.75	4.1251	4.4197	1.4180	4.25	143.4951	153.7448	49.3264
2.00	7.0372	7.5399	2.4190	4.50	180.3564	193.2390	61.9975
2.25	11.2723	12.0774	3.8748	4.75	223.9009	239.8939	76.9659
2.50	17.1807	18.4079	5.9059	5.00	274.8916	294.5267	94.4940

Coefficients of Static Friction Materials (Dry Contact Unless Noted)

	μS
Steel on Steel	0.58
Steel on Steel (lubricated)	0.15
Aluminum on Steel	0.45
Copper on Steel	0.22
Brass on Steel	0.19
Teflon on Steel	0.04

Leadscrew Efficiencies

Type	Efficiency (%)		
	High	Median	Low
Ball-nut	95	90	85
Acme with metal nut*	55	40	35
Acme with plastic nut	85	65	50

* Since metallic nuts usually require a viscous lubricant, the coefficient of friction is both speed and temperature dependent.

System Calculations

Leadscrew Drives

Vertical or Horizontal Application:

ST – Screw type, ball or acme	ST = _____
e – Efficiency of screw	e = _____ %
μ_s – Friction coefficient	μ_s = _____
L – Length of screw	L = _____ inches
D – Diameter of screw	D = _____ inches
p – Pitch	p = _____ threads/inch
W – Weight of load	W = _____ lbs.
F – Breakaway force	F = _____ ounces
Directly coupled to the motor?	yes/no _____
If yes, CT – Coupling type	_____
If no, belt & pulley or gears	_____
Radius of pulley or gear	_____ inches
Gear: Number of teeth – Gear 1	_____
Number of teeth – Gear 2	_____
Weight of pulley or gear	_____ ounces
Weight of belt	_____ ounces

Leadscrew Formulas

The torque required to drive load W using a leadscrew with pitch (p) and efficiency (e) has the following components:

$$T_{\text{Total}} = T_{\text{Friction}} + T_{\text{Acceleration}}$$

$$T_{\text{Friction}} = \frac{F}{2\pi p e}$$

Where:

- F = frictional force in ounces
- p = pitch in revs/in
- e = leadscrew efficiency

$F = \mu_s W$ for horizontal surfaces where μ_s = coefficient of static friction and W is the weight of the load. This friction component is often called "breakaway".

Dynamic Friction: $F = \mu_d W$ is the coefficient to use for friction during a move profile. However, torque calculations for acceleration should use the worst case friction coefficient, μ_s .

$$T_{\text{Accel}} = \frac{1}{g} (J_{\text{Load}} + J_{\text{Leadscrew}} + J_{\text{Motor}}) \frac{\omega}{t}$$

$$\omega = 2\pi p v$$

$$J_{\text{Load}} = \frac{W}{(2\pi p)^2}; J_{\text{Leadscrew}} = \frac{\pi L \rho R^4}{2}$$

Where:

- T = torque, oz-in
- ω = angular velocity, radians/sec
- t = time, seconds
- v = linear velocity, in/sec
- L = length, inches
- R = radius, inches
- ρ = density, ounces/in³
- g = gravity constant, 386 in/sec²

The formula for load inertia converts linear inertia into the rotational equivalent as reflected to the motor shaft by the leadscrew.

Problem

Find the torque required to accelerate a 200-lb steel load sliding on a steel table to 2 inches per second in 100 milliseconds using a 5 thread/inch steel leadscrew 36 inches long and 1.5 inches in

diameter. Assume that the leadscrew has an Acme thread and uses a plastic nut. Motor inertia is given as 6.56 oz-in². In this example, we assume a horizontally oriented leadscrew where the force of gravity is perpendicular to the direction of motion. In non-horizontal orientations, leadscrews will transmit varying degrees of influence from gravity to the motor, depending on the angle of inclination. Compumotor Sizing Software automatically calculates these torques using vector analysis.

1. Calculate the torque required to overcome friction. The coefficient of static friction for steel-to-steel lubricant contact is 0.15. The median value of efficiency for an Acme thread and plastic nut is 0.65. Therefore:

$$F = \mu_s W = 0.15 (200 \text{ lb}) \frac{(16 \text{ oz})}{\text{lb}} = 480 \text{ oz}$$

$$T_{\text{Friction}} = \frac{F}{2\pi p e} = \frac{480 \text{ oz}}{2\pi \times 5 \frac{\text{rev}}{\text{in}} \times 0.65} = 23.51 \text{ oz-in}$$

2. Compute the rotational inertia of the load and the rotational inertia of the leadscrew:

$$J_{\text{Load}} = \frac{W}{(2\pi p)^2} = \frac{200 \text{ lb}}{(2\pi \times 5)^2} \times \frac{16 \text{ oz}}{\text{lb}} = 3.24 \text{ oz-in}^2$$

$$J_{\text{Leadscrew}} = \frac{\pi L \rho R^4}{2} = \frac{\pi}{2} (36 \text{ in}) (4.48 \frac{\text{oz}}{\text{in}^3}) (0.75 \text{ in})^4 = 80.16 \text{ oz-in}^2$$

3. The torque required to accelerate the load may now be computed since the motor inertia was given:

$$T_{\text{Accel}} = \frac{1}{g} (J_{\text{Load}} + J_{\text{Leadscrew}} + J_{\text{Motor}}) \frac{\omega}{t}$$

$$\omega = 2\pi \left(\frac{5}{\text{in}}\right) \left(\frac{2 \text{ in}}{\text{sec}}\right) = \frac{20\pi}{\text{sec}}$$

$$= \frac{1}{386 \text{ in/sec}^2} (4.99 + 80.16 + 6.56(\text{oz-in}^2)) \frac{20\pi}{0.1 \text{ sec}}$$

$$= 149 \text{ oz-in}$$

$$T_{\text{Total}} = T_{\text{Friction}} + T_{\text{Accel}}$$

$$T_{\text{Total}} = 23.51 \text{ oz-in} + 149 \text{ oz-in} = 172.51 \text{ oz-in}$$

Directly Driven Loads

There are many applications where the motion being controlled is rotary and the low-speed smoothness and high resolution of a Compumotor system can be used to eliminate gear trains or other mechanical linkages. In direct drive applications, a motor is typically connected to the load through a

flexible or compliant coupling. This coupling provides a small amount of damping and helps correct for any mechanical misalignment.

Direct drive is attractive when mechanical simplicity is desirable and the load being driven is of moderate inertia.

Direct Drive Formulas

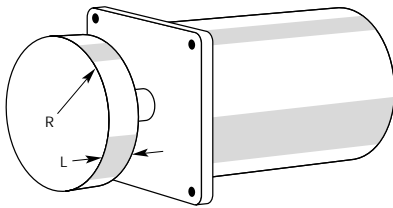

- R – Radius
- R(1) – Inner radius
- R(2) – Outer radius
- L – Length
- W – Weight of disc
- ρ – Density/Material
- g – Gravity constant

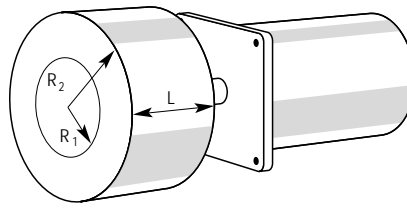

- R = _____ inches
- R(1) = _____ inches
- R(2) = _____ inches
- L = _____ inches
- W = _____ ounces
- ρ = _____ ounces/inch³
- g = _____ 386 in/sec²

Solid Cylinder (oz-in²)

$$\text{Inertia: } J_{\text{Load}} = \frac{WR^2}{2}$$

Where weight and radius are known

$$\text{Inertia (oz-in}^2\text{) } J_{\text{Load}} = \frac{\pi L \rho R^4}{2}$$

Where ρ , the material density is known

$$\text{Weight } W = \pi L \rho R^2$$

Inertia may be calculated knowing either the weight and radius of the solid cylinder (W and R) or its density, radius and length (ρ , R and L.)

The torque required to accelerate any load is:

$$T \text{ (oz-in)} = Ja$$

$$a = \frac{\omega_2 - \omega_1}{t} = 2\pi \text{ (accel.) for Accel. in rps}^2$$

Where:

a = angular acceleration, radians/sec²

ω_2 = final velocity, radians/sec

ω_1 = initial velocity, radians/sec

t = time for velocity change, seconds

J = inertia in units of oz-in²

The angular acceleration equals the time rate of change of the angular velocity. For loads accelerated from zero, $\omega_1 = 0$ and $a = \frac{\omega}{t}$

$$T_{\text{Total}} = \frac{1}{g} (J_{\text{Load}} + J_{\text{Motor}}) \frac{\omega}{t}$$

T_{Total} represents the torque the motor must deliver.

The gravity constant (g)

in the denominator

represents acceleration

due to gravity (386 in/

sec²) and converts

inertia from units of oz-

in² to oz-in-sec².

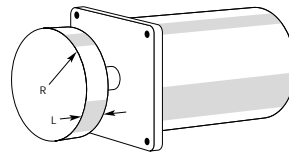

Hollow Cylinder

$$J_{\text{Load}} = \frac{W}{2} (R_1^2 + R_2^2)$$

Where W, the weight, is known

or

$$J_{\text{Load}} = \frac{\pi L \rho}{2} (R_2^4 - R_1^4)$$

Where ρ , the density, is known

$$W = \pi L \rho (R_2^2 - R_1^2)$$

$$T = \frac{1}{g} (J_{\text{Load}} + J_{\text{Motor}}) \frac{\omega}{t}$$

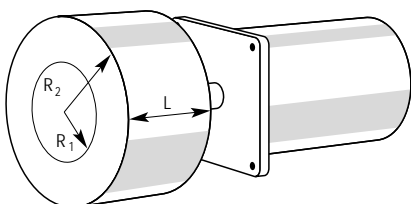

Problem

Calculate the motor torque required to accelerate a solid cylinder of aluminum 5" in radius and 0.25" thick from rest to 2.1 radians/sec (0.33 revs/sec) in 0.25 seconds. First, calculate J_{Load} using the density for aluminum of 1.54 oz/in³.

$$J_{\text{Load}} = \frac{\pi L \rho R^4}{2} = \frac{\pi \times 0.25 \times 1.54 \times 5^4}{2} = 378 \text{ oz-in}^2$$

Assume the rotor inertia of the motor you will use is 37.8 oz-in².

$$\begin{aligned} T_{\text{Total}} &= \frac{1}{g} (J_{\text{Load}} + J_{\text{Motor}}) \times \frac{\omega}{t} \\ &= \frac{1}{386} \times (378 + 37.8) \times \frac{2.1}{0.25} \\ &= 9.05 \text{ oz-in} \end{aligned}$$

System Calculations

Gear Drives

Traditional gear drives are more commonly used with step motors. The fine resolution of a microstepping motor can make gearing unnecessary in many applications. Gears generally have undesirable efficiency, wear characteristics, backlash, and can be noisy.

Gears are useful, however, when very large inertias must be moved because the inertia of the load

reflected back to the motor through the gearing is divided by the square of the gear ratio.

In this manner, large inertial loads can be moved while maintaining a good load-inertia to rotor-inertia ratio (less than 10:1).

Gear Driven Loads

R – Radius	R = _____ inches
R(1) – Radius gear #1	R(1) = _____ inches
R(2) – Radius gear #2	R(2) = _____ inches
N(1) – Number of teeth G#1	N(1) = _____
N(2) – Number of teeth G#2	N(2) = _____
G – Gear ratio $\frac{N(1)}{N(2)}$	G = _____
W – Weight of load	W = _____ ounces
W(1) – Weight G#1	W(1) = _____ ounces
W(2) – Weight G#2	W(2) = _____ ounces
L – Length	L = _____ inches
F – Friction	F = _____
BT – Breakaway torque	BT = _____ ounce/inches

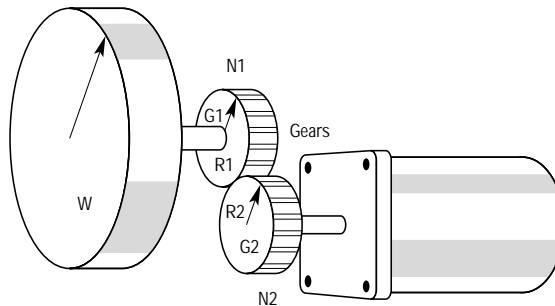

Gear Drive Formulas

$$J_{\text{Load}} = \frac{W_{\text{Load}}}{2} R_{\text{Load}}^2 \left(\frac{N_{\text{Gear 2}}}{N_{\text{Gear 1}}} \right)^2$$

OR

$$J_{\text{Load}} = \frac{\pi L_{\text{Load}} \rho_{\text{Load}}}{2} R_{\text{Load}}^4 \left(\frac{N_{\text{Gear 2}}}{N_{\text{Gear 1}}} \right)^2$$

$$J_{\text{Gear 1}} = \frac{W_{\text{Gear 1}}}{2} R_{\text{Gear 1}}^2 \left(\frac{N_{\text{Gear 2}}}{N_{\text{Gear 1}}} \right)^2$$

$$J_{\text{Gear 2}} = \frac{W_{\text{Gear 2}}}{2} R_{\text{Gear 2}}^2$$

$$T_{\text{Total}} = \frac{1}{g} (J_{\text{Load}} + J_{\text{Gear 1}} + J_{\text{Gear 2}} + J_{\text{Motor}}) \frac{\omega}{t}$$

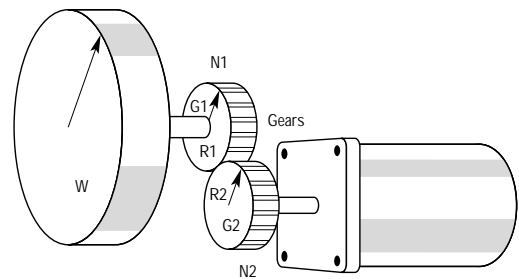

Where:

- J = inertia, oz-in (gm-cm²) "as seen by the motor"
- T = torque, oz-in (gm-cm)
- W = weight, oz (gm)
- R = radius, in. (cm)
- N = number of gear teeth (constant)
- L = length, in (cm)
- ρ = density, oz/in³ (gm/cm³)
- ω = angular velocity, radians/sec @ motor shaft
- t = time, seconds
- g = gravity constant, 386 in/sec²

Tangential Drives

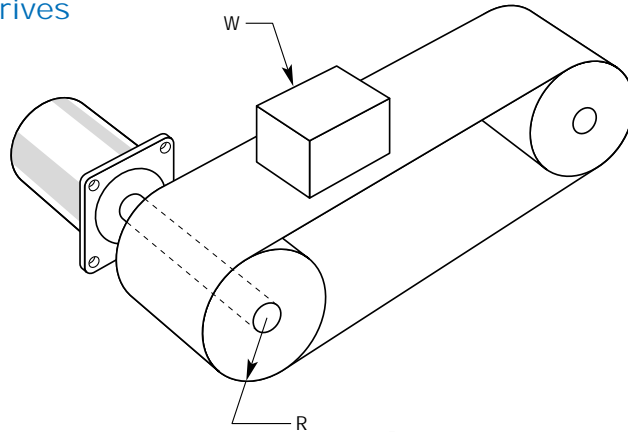

R- Radius

W – Weight (include weight of belt or chain)

W(P) – Weight of pulley or material

F – Breakaway force

V – Linear velocity

CT – Coupling type

SL – Side load

R = _____ inches

W = _____ ounces

W(P) _____ ounces

F = _____ ounces

V = _____ inches/sec

CT = _____

SL = _____

Tangential Drive Formulas

$$T_{Total} = T_{Load} + T_{Pulley} + T_{Belt} + T_{Motor} + T_{Friction}$$

$$T_{Total} = \frac{1}{g} (J_{Load} + J_{Pulley} + J_{Belt} + J_{Motor}) \frac{\omega}{t} + T_{Friction}$$

$$J_{Load} = W_L R^2$$

$$J_{Pulley} = \frac{W_P R^2}{2} \quad (\text{Remember to multiply by 2 if there are 2 pulleys.})$$

$$J_{Belt} = W_B R^2$$

$$T_{Friction} = FR$$

$$\omega = \frac{V}{R}$$

Where:

T = torque, oz-in (gm-cm)

ω = angular velocity, radians/sec

t = time, seconds

W_L = weight of the load, oz

W_P = pulley weight, oz

W_B = belt or rack weight, oz

F = frictional force, oz (gm)

R = radius, in (cm)

V = linear velocity

g = gravity constant, 386 in/sec²

ρ = density, oz/in³

Problem

What torque is required to accelerate a 5-lb load to a velocity of 20 inches per second in 10 milliseconds using a flat timing belt? The motor drives a 2-inch diameter steel pulley 1/2-inch wide. The timing belt weighs 12 oz. Load static friction is 30 ozs. Motor rotor inertia is 10.24 oz-in.²

$$J_{Load} = W_L R^2 = 5 \text{ lb} \times 16 \frac{\text{oz}}{\text{lb}} \times (1 \text{ in})^2 = 80 \text{ oz-in}^2$$

$$J_{Pulley} = \frac{2(\pi L \rho R^4)}{2} = \pi \times 0.5 \text{ in} \times (4.48 \text{ oz/in}^3) (1 \text{ in})^4$$

$$= 7.04 \text{ oz-in}^2$$

$$J_{Belt} = W_B R^2 = 12 \text{ oz} (1 \text{ in})^2 = 12 \text{ oz-in}^2$$

$$T_{Friction} = F \times R = 30 \text{ oz} \times 1 \text{ in} = 30 \text{ oz-in}$$

$$\omega = \frac{V}{R} = 20 \frac{\text{in}}{\text{sec}} \times \frac{1 \text{ rad}}{1 \text{ in}} = 20 \frac{\text{rad}}{\text{sec}}$$

$$T_{Total} = \frac{1}{386} (80 + 7.04 + 12 + 10.24) \frac{20}{.01} + 30$$

$$T_{Total} = 596.2 \text{ oz-in}$$

Linear Step Motors

There are many characteristics to consider when designing, selecting and installing a complete motion control system. The applications data worksheet and the application considerations detailed below will help determine if a linear motor system is recommended for a given application. A linear motor, when properly specified, will provide the optimum performance and the greatest reliability.

Application Data Worksheet #1

Application: Single Axis Multi-Axis X-Y Gantry

Description of system operation: A part is moved in and out of a machine very quickly. The part comes to rest at the same point in the machine each time. An operator sets this distance with a thumbwheel switch.

Sketch the proposed mechanical configuration:

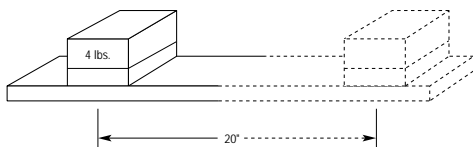

1. Motor Sizing	AXIS 1
A. Weight of payload (lbs)	10.0
B. Fixed forces, if any (lbs)	0
C. Known move distance (in)	40
time (sec)	1.0
D. Angle from horizontal (degrees)	0
2. Total length of travel (inches)	40
3. Desired repeatability (in)	.001
4. Desired resolution (in)	.0005
5. Necessary settling time after move	
100 ms to within	.001 inches
6. Life expectancy:	
Percent duty cycle	20%
Estimated number of moves/year	200,000
7. Is the center of gravity significantly changed?	no
8. What is the environment? clean <input checked="" type="checkbox"/> dirty <input type="checkbox"/>	
Specifics	
9. Operating temperature range	65° to 85°F
10. Can air be available?	yes

The Solution

Actual and assumed factors that contribute to the solution are:

1. Force (F) = mass (M) x acceleration (A)
Note: mass units are in pounds
2. Acceleration due to gravity
(1g=386 inches/sec²)
3. L20 forcer weighs 2.0 lb.
4. Attractive force between L20 forcer and platen = 200 lbs.
5. Trapezoidal velocity profile:
Accel time = 1.0 sec/4
= 0.250 sec.
Vmax = 1.33 x Vavg

Step 1: Total mass to be accelerated
Mtotal = Mload (10.0) + Mforcer (2.0) = 12.0 lbs.

Step 2: Acceleration rate

A. Average velocity = $\frac{\text{move distance}}{\text{move time}}$
= $\frac{40 \text{ inches}}{1.0 \text{ sec}}$
= 40.0 in/sec

B. Maximum velocity
(Based on trapezoidal move profile)
Vmax = 1.33 x Vavg (40.0 in/sec)
= 53.2 in/sec

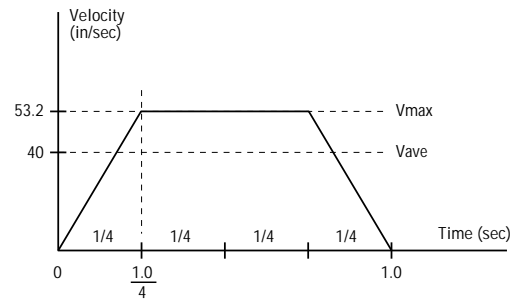

C. Minimum acceleration rate
A = $\frac{V_{\text{max}} (53.2 \text{ in/sec})}{\text{Accel. time } (.250 \text{ sec})}$
= $\frac{\text{Minimum acceleration } (212.8 \text{ in/sec}^2)}{386 \text{ in/sec}^2 \text{ per } 1 \text{ G}}$
= 0.551 g's

Step 3: Calculate maximum acceleration rate of L20 (using constant acceleration indexer).

Based on the speed/force curve below, the L20 has 14.0 lbs of force at 53.2 in/sec (Vmax).

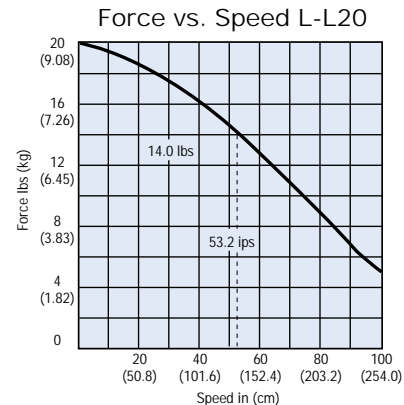

Step 4: Non-damped safety margin

If all available force could be used, the maximum calculated acceleration rate:

$$A_{\text{max}} = \frac{\text{Force } (14.0 \text{ lb})}{M_{\text{total}} (12.0 \text{ lbs.})} = 1.16 \text{ g's}$$

The calculated acceleration rate should be reduced by 50% (100% non-damped safety margin) netting an acceleration rate for the L20 of 0.58 g's. The application requires a 0.55 g's acceleration rate. The L20 meets the requirements of this application.

Velocity Ripple

Velocity ripple is most noticeable when operating near the motor's resonant frequency. Rotary stepping motor's have this tendency as well, but it is usually less noticeable due to mechanical losses in the rotary-to-linear transmission system, which dampens the effects. Velocity ripple due to resonance can be reduced with the electronic accelerometer damping option (-AC).

Platen Mounting

The air gap between the forcer and the platen surface can be as small as 0.0005 inches. Properly mounting the platen is extremely important. When held down on a magnetic chuck, the platen is flat and parallel within its specifications, however, in its free state, slight bows and twists may cause the forcer (L20) to touch the platen at several places. Compumotor recommends mounting the platen using *all* its mounting holes on a ground flat piece of steel, such as an I-beam, U-channel or tube.

Environment

Due to the small air gap between the forcer and platen, care should be taken to keep the platen clean. A small amount of dirt or adhesive material (such as paint) can cause a reduction in motor performance. When appropriate, mounting the motor upside down or on its side will help keep foreign particles off the platen. Protective boots that fold like an accordion as the motor travels can also be used to assist in keeping the platen clean.

Linear Step Motors

Life Expectancy

The life of a mechanical bearing motor is limited by wearing of the platen surface over which the bearings roll. Factors that affect wear and life of a mechanical bearing system include:

- A. High velocities – Life is inversely proportional to velocity cubed. Increasing velocity raises the temperature of the platen due to eddy current losses in the solid platen material. (In normal high-speed, high duty cycle operation over a small piece of platen, the platen can become almost too hot to touch.)
- B. Load on the forcer – Load has some effect on the life expectancy of the linear motor. Users are urged to adhere to the load specifications for each motor.

Yaw, Pitch and Roll

In applications such as end effector devices or where the load is located far from the motor's center of gravity, the stiffness characteristics of the forcer must be considered. Moment producing forces tend to deflect the forcer, and if strong enough, will cause the motor to stall or be removed from the platen. Yaw, pitch and roll specifications are used to determine the maximum torque you can apply to the forcer.

Accuracy

In linear positioning systems, some applications require high absolute accuracy, while many applications require a high degree of repeatability. These two variables should be reviewed to accurately evaluate proper system performance.

In the "teach mode", a linear motor can be positioned and subsequently learn the coordinates of any given point. After learning a number of points in a sequence of moves, the user will be concerned with the ability of the forcer to return to the same position from the same direction. This scenario describes repeatability.

In a different application, a linear motor is used to position a measuring device. The size of an object can be measured by positioning the forcer to a point on the object. Determining the measured value is based on the number of steps required to reach the point on the object. System accuracy must be smaller than the tolerance on the desired measurement.

Open-loop absolute accuracy of a linear step motor is typically less than a precision grade leadscrew system. If a linear encoder is used in conjunction with a linear motor, the accuracy will be equivalent to any other transmission system.

The worst-case accuracy of the system is the sum of these errors:

$$\text{Accuracy} = A + B + C + D + E + F$$

- A = Cyclic Error – The error due to motor magnetics that recurs once every pole pitch as measured on the body of the motor.
- B = Unidirectional Repeatability – The error measured by repeated moves to the same point from different distances in the same direction.
- C = Hysteresis – The backlash of the motor when changing direction due to magnetic non-linearity and mechanical friction.
- D = Cumulative Platen Error – Linear error of the platen as measured on the body of the motor.
- E = Random Platen Error – The non-linear errors remaining in the platen after the linear is disregarded.
- F = Thermal Expansion Error – The error caused by a change in temperature expanding or contracting the platen.

Glossary of Terms

Absolute Positioning

Refers to a motion control system employing position feedback devices (absolute encoders) to maintain a given mechanical location.

Absolute Programming

A positioning coordinate referenced wherein all positions are specified relative to some reference, or "zero" position. This is different from incremental programming, where distances are specified relative to the current position.

AC Servo

A general term referring to a motor drive that generates sinusoidal shaped motor currents in a brushless motor wound as to generate sinusoidal back EMF.

Acceleration

The change in velocity as a function of time. Acceleration usually refers to increasing velocity and deceleration describes decreasing velocity.

Accuracy

A measure of the difference between expected position and actual position of a motor or mechanical system. Motor accuracy is usually specified as an angle representing the maximum deviation from expected position.

Ambient Temperature

The temperature of the cooling medium, usually air, immediately surrounding the motor or another device.

ASCII

American Standard Code for Information Interchange. This code assigns a number series of electrical signals to each numeral and letter of the alphabet. In this manner, information can be transmitted between machines as a series of binary numbers.

Bandwidth

A measure of system response. It is the frequency range that a control system can follow.

BCD

Binary Coded Decimal is an encoding technique used to describe the numbers 0 through 9 with four digital (on or off) signal lines. Popular in machine tool equipment, BCD interfaces are now giving way to interfaces requiring fewer wires – such as RS-232C.

Bit

Abbreviation of Binary Digit, the smallest unit of memory equal to 1 or 0.

Back EMF

The voltage produced across a winding of a motor due to the winding turns being cut by a magnetic field while the motor is operating. This voltage is directly proportional to rotor velocity and is opposite in polarity to the applied voltage. Sometimes referred to as *counter EMF*.

Block Diagram

A simplified schematic representing components and signal flow through a system.

Bode Plot

A graph of system gain and phase versus input frequency which graphically illustrates the steady state characteristics of the system.

Break Frequency

Frequency(ies) at which the gain changes slope on a Bode plot (break frequencies correspond to the poles and zeroes of the system).

Brushless DC Servo

A general term referring to a motor drive that generates trapezoidal shaped motor currents in a motor wound as to generate trapezoidal Back EMF.

Byte

A group of 8 bits treated as a whole, with 256 possible combinations of one's and zero's, each combination representing a unique piece of information.

Commutation

The switching sequence of drive voltage into motor phase windings necessary to assure continuous motor rotation. A brushed motor relies upon brush/bar contact to mechanically switch the windings. A brushless motor requires a device that senses rotor rotational position, feeds that information to a drive that determines the next switching sequence.

Closed Loop

A broadly applied term relating to any system where the output is measured and compared to the input. The output is then adjusted to reach the desired condition. In motion control, the term describes a system wherein a velocity or position (or both) transducer is used to generate correction signals by comparison to desired parameters.

Critical Damping

A system is critically damped when the response to a step change in desired velocity or position is achieved in the minimum possible time with little or no overshoot.

Crossover Frequency

The frequency at which the gain intercepts the 0 dB point on a Bode plot (used in reference to the open-loop gain plot).

Daisy-Chain

A term used to describe the linking of several RS-232C devices in sequence such that a single data stream flows through one device and on to the next. Daisy-chained devices usually are distinguished by device addresses, which serve to indicate the desired destination for data in the stream.

Damping

An indication of the rate of decay of a signal to its steady state value. Related to settling time.

Damping Ratio

Ratio of actual damping to critical damping. Less than one is an underdamped system and greater than one is an overdamped system.

Dead Band

A range of input signals for which there is no system response.

Decibel

A logarithmic measurement of gain. If G is a system's gain (ratio of output to input), then $20 \log G = \text{gain in decibels (dB)}$.

Detent Torque

The minimal torque present in an unenergized motor. The detent torque of a step motor is typically about 1% of its static energized torque.

Direct Drive Servo

A high-torque, low-speed servo motor with a high resolution encoder or resolver intended for direct connection to the load without going through a gearbox.

Duty Cycle

For a repetitive cycle, the ratio of on time to total cycle time.

$$\text{Duty cycle} = \frac{\text{On Time}}{(\text{On Time} + \text{Off Time})}$$

Efficiency

The ratio of power output to power input.

Electrical Time Constant

The ratio of armature inductance to armature resistance.

Encoder

A device that translates mechanical motion into electronic signals used for monitoring position or velocity.

Form Factor

The ratio of the RMS value of a harmonic signal to its average value in one half-wave.

Friction

A resistance to motion. Friction can be constant with varying speed (Coulomb friction) or proportional to speed (viscous friction).

Gain

The ratio of system output signal to system input signal.

Holding Torque

Sometimes called static torque, it specifies the maximum external force or torque that can be applied to a stopped, energized motor without causing the rotor to rotate continuously.

Home

A reference position in a motion control system derived from a mechanical datum or switch. Often designated as the “zero” position.

Hybrid Servo

A brushless servo motor based on a conventional hybrid stepper. It may use either a resolver or encoder for commutation feedback.

Hysteresis

The difference in response of a system to an increasing or a decreasing input signal.

IEEE-488

A digital data communications standard popular in instrumentation electronics. This parallel interface is also known as GPIB, or General Purpose Interface Bus.

Incremental Motion

A motion control term that describes a device that produces one step of motion for each step command (usually a pulse) received.

Incremental Programming

A coordinate system where positions or distances are specified relative to the current position.

Inertia

A measure of an object’s resistance to a change in velocity. The larger an object’s inertia, the larger the torque that is required to accelerate or decelerate it. Inertia is a function of an object’s mass and its shape.

Inertial Match

For most efficient operation, the system coupling ratio should be selected so that the reflected inertia of the load is equal to the rotor inertia of the motor.

Indexer

See PMC.

I/O

Abbreviation of input/output. Refers to input signals from switches or sensors and output signals to relays, solenoids etc.

Lead Compensation Algorithm

A mathematical equation implemented by a computer to decrease the delay between the input and output of a system.

Limits

Properly designed motion control systems have sensors called limits that alert the control electronics that the physical end of travel is being approached and that motion should stop.

Logic Ground

An electrical potential to which all control signals in a particular system are referenced.

Mechanical Time Constant

The time for an energized DC motor to reach 2/3rds of its set velocity. Based on a fixed voltage applied to the windings.

Mid-range Instability

Designates the condition resulting from energizing a motor at a multiple of its natural frequency (usually the third orders condition). Torque loss and oscillation can occur in underdamped open-loop systems.

Microstepping

An electronic control technique that proportions the current in a step motor’s windings to provide additional intermediate positions between poles. Produces smooth rotation over a wide speed range and high positional resolution.

Open Collector

A term used to describe a signal output that is performed with a transistor. An open collector output acts like a switch closure with one end of the switch at ground potential and the other end of the switch accessible.

Open Loop

Refers to a motion control system where no external sensors are used to provide position or velocity correction signals.

Opto-isolated

A method of sending a signal from one piece of equipment to another without the usual requirement of common ground potentials. The signal is transmitted optically with a light source (usually a Light Emitting Diode) and a light sensor (usually a photosensitive transistor). These optical components provide electrical isolation.

Parallel

Refers to a data communication format wherein many signal lines are used to communicate more than one piece of data at the same time.

Phase Angle

The angle at which the steady state input signal to a system leads the output signal.

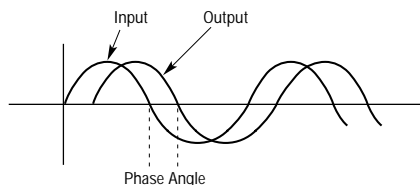

Phase Margin

The difference between 180° and the phase angle of a system at its crossover frequency.

PLC

Programmable logic controller; a machine controller that activates relays and other I/O units from a stored program. Additional modules support motion control and other functions.

PMC

Programmable motion controller, primarily designed for single- or multi-axis motion control with I/O as an auxiliary function.

Pole

A frequency at which the transfer function of a system goes to infinity.

Pulse Rate

The frequency of the step pulses applied to a motor driver. The pulse rate multiplied by the resolution of the motor/drive combination (in steps per revolution) yields the rotational speed in revolutions per second.

PWM

Pulse Width Modulation. A method of controlling the average current in a motor’s phase windings by varying the on-time (duty cycle) of transistor switches.

Ramping

The acceleration and deceleration of a motor. May also refer to the change in frequency of the applied step pulse train.

Rated Torque

The torque producing capacity of a motor at a given speed. This is the maximum torque the motor can deliver to a load and is usually specified with a torque/speed curve.

Regeneration

Usually refers to a circuit in a drive amplifier that accepts and drains energy produced by a rotating motor either during deceleration or free-wheel shutdown.

Registration Move

Changing the predefined move profile that is being executed, to a different predefined move profile following receipt of an input or interrupt.

Repeatability

The degree to which the positioning accuracy for a given move performed repetitively can be duplicated.

Resolution

The smallest positioning increment that can be achieved. Frequently defined as the number of steps required for a motor’s shaft to rotate one complete revolution.

Resolver

A feedback device with a construction similar to a motor’s construction (stator and rotor). Provides velocity and position information to a drive’s microprocessor or DSP to electronically commutate the motor.

Resonance

Designates the condition resulting from energizing a motor at a frequency at or close to the motor's natural frequency. Lower resolution, open-loop systems will exhibit large oscillations from minimal input.

Ringing

Oscillation of a system following a sudden change in state.

RMS Torque

For an intermittent duty cycle application, the RMS Torque is equal to the steady- state torque that would produce the same amount of motor heating over long periods of time.

$$T_{\text{RMS}} = \sqrt{\frac{\sum (T_i^2 t_i)}{\sum t_i}}$$

Where: T_i = Torque during interval i
 t_i = Time of interval i

RS-232C

A data communications standard that encodes a string of information on a single line in a time sequential format. The standard specifies the proper voltage and time requirements so that different manufacturers devices are compatible.

Servo

A system consisting of several devices which continuously monitor actual information (position, velocity), compares those values to desired outcome and makes necessary corrections to minimize that difference.

Slew

In motion control, the portion of a move made at a constant non-zero velocity.

Static Torque

The maximum torque available at zero speed.

Step Angle

The angle the shaft rotates upon receipt of a single step command.

Stiffness

The ability to resist movement induced by an applied torque. Is often specified as a torque displacement curve, indicating the amount a motor shaft will rotate upon application of a known external force when stopped.

Synchronism

A motor rotating at a speed correctly corresponding to the applied step pulse frequency is said to be in synchronism. Load torques in excess of the motor's capacity (rated torque) will cause a loss of synchronism. The condition is not damaging to a step motor.

Torque

Force tending to produce rotation.

Torque Constant

K_T = The torque generated in a DC motor per unit Ampere applied to its windings.

$$K_T = \frac{\text{T oz-in}}{\text{A amp}}$$

Simplified for a brushless motor at 90° commutation angle.

Torque Ripple

The cyclical variation of generated torque at a frequency given by the product of motor angular velocity and number of commutator segments or magnetic poles.

Torque-to-Inertia Ratio

Defined as a motor's holding torque divided by the inertia of its rotor. The higher the ratio, the higher a motor's maximum acceleration capability will be.

Transfer Function

A mathematical means of expressing the output to input relationship of a system. Expressed as a function of frequency.

Triggers

Inputs on a controller that initiate or "trigger" the next step in a program.

TTL

Transistor-Transistor Logic. Describes a common digital logic device family that is used in most modern digital electronics. TTL signals have two distinct states that are described with a voltage – a logical "zero" or "low" is represented by a voltage of less than 0.8 volts and a logical "one" or "high" is represented by a voltage from 2.5 to 5 volts.

Voltage Constant

K_E = The back EMF generated by a DC motor at a defined speed. Usually quoted in volts per 1000 rpm.

Zero

A frequency at which the transfer function of a system goes to zero.

Rotary Inertia Conversion Table

Don't confuse mass-inertia with weight-inertia: mass inertia = $\frac{\text{wt. inertia}}{g}$

To convert from A to B, multiply by entry in Table.

A	B											
	kg-m ²	kg-cm ²	g-cm ²	kg-m-sec ²	kg-cm-sec ²	g-cm-sec ²	oz-in ²	oz-in-s ²	lb-in ²	lb-in-s ²	lb-ft ²	lb-ft-s ² (slug-ft ²)
kg-m ²	1	10 ⁴	10 ⁷	0.10192	10.1972	1.01972-10 ⁴	5.46745-10 ⁴	1.41612-10 ²	3.41716-10 ³	8.850732	23.73025	0.73756
kg-cm ²	10 ⁻⁴	1	10 ³	1.01972-10 ⁻⁵	1.01972-10 ⁻³	1.01972	5.46745	1.41612-10 ⁻²	0.341716	8.85073-10 ⁻⁴	2.37303-10 ⁻³	7.37561-10 ⁻⁵
g-cm ²	10 ⁻⁷	10 ⁻³	1	1.01972-10 ⁻⁸	1.01972-10 ⁻⁶	1.01972-10 ⁻³	5.46745-10 ⁻³	1.41612-10 ⁻⁵	3.41716-10 ⁻⁴	8.85073-10 ⁻⁷	2.37303-10 ⁻⁶	7.37561-10 ⁻⁸
kg-m-s ²	9.80665	9.80665-10 ⁴	9.80665-10 ⁷	1	10 ²	10 ⁵	5.36174-10 ⁵	1.388674-10 ³	3.35109-10 ⁴	86.79606	2.32714-10 ²	7.23300
kg-cm-s ²	9.80665-10 ⁻²	9.80665-10 ⁻²	9.80665-10 ⁵	10 ⁻²	1	10 ³	5.36174-10 ³	13.88741	3.35109-10 ²	0.86796	2.327143	7.23300-10 ⁻²
g-cm-s ²	9.80665-10 ⁻⁵	0.980665	9.80665-10 ²	10 ⁻⁵	10 ⁻³	1	5.36174	1.38874-10 ⁻²	0.335109	8.67961-10 ⁻⁴	2.32714-10 ⁻³	7.23300-10 ⁻⁵
oz-in ²	1.82901-10 ⁻⁵	0.182901	1.82901-10 ²	1.86506-10 ⁻⁶	1.86506-10 ⁻⁴	0.186506	1	2.59008-10 ⁻³	6.250-10 ⁻²	1.61880-10 ⁻⁴	4.34028-10 ⁻⁴	1.34900-10 ⁻⁵
oz-in-s ²	7.06154-10 ⁻³	70.6154	7.06154-10 ⁴	7.20077-10 ⁻⁴	7.20077-10 ⁻²	72.00766	3.86089-10 ²	1	24.13045	6.250-10 ⁻²	0.167573	5.20833-10 ⁻³
lb-in ²	2.92641-10 ⁻⁴	2.92641	2.92641-10 ³	2.98411-10 ⁻⁵	2.98411-10 ⁻³	2.98411	16	4.14414-10 ⁻²	1	2.59008-10 ⁻³	6.94444-10 ⁻³	2.15840-10 ⁻⁴
lb-in-s ²	0.112985	1.12985-10 ³	1.12985-10 ⁶	1.15213-10 ⁻²	1.152126	1.15213-10 ³	6.17740-10 ³	16	3.86088-10 ²	1	2.681175	8.3333-10 ⁻²
lb-ft ²	4.21403-10 ⁻²	4.21403-10 ²	4.21403-10 ⁵	4.29711-10 ⁻³	0.429711	4.297114-10 ²	2.304-10 ³	5.96755	144	0.372971	1	3.10809-10 ⁻²
lb-ft-s ² (slug ft ²)	1.35583	1.35582-10 ⁴	1.35582-10 ⁷	0.138255	13.82551	1.38255-10 ⁴	7.41289-10 ⁴	192	4.63306-10 ³	12	32.1740	1

Torque Conversion Table

To convert from A to B, multiply by entry in Table.

A	B								
	N-m	N-cm	dyn-cm	kg-m	kg-cm	g-cm	oz-in	ft-lbs	in-lbs
N-m	1	10 ²	10 ⁷	0.1019716	10.19716	1.019716-10 ⁴	141.6119	0.737562	8.85074
N-cm	10 ⁻²	1	10 ⁵	1.019716-10 ⁻³	0.1019716 ⁻³	1.019712-10 ²	1.41612	7.37562-10 ⁻³	8.85074-10 ⁻²
dyn-cm	10 ⁻⁷	10 ⁻⁵	1	1.019716-10 ⁻⁸	1.01972-10 ⁻⁶	1.01972-10 ⁻³	1.41612-10 ⁻⁵	7.37562-10 ⁻⁸	8.85074-10 ⁻⁷
kg-m	9.80665	9.80665-10 ²	9.80665-10 ⁷	1	10 ²	10 ⁵	1.38874-10 ³	7.23301	86.79624
kg-cm	9.80665-10 ⁻²	9.80665	9.80665-10 ⁵	10 ⁻²	1	10 ³	13.8874	7.23301-10 ⁻²	0.86792
g-cm	9.80665-10 ⁻⁵	9.80665-10 ⁻³	9.80665-10 ²	10 ⁻⁵	10 ⁻³	1	1.38874-10 ⁻²	7.23301-10 ⁻⁵	8.679624-10 ⁻⁴
oz-in	7.06155-10 ⁻³	0.706155	7.06155-10 ⁴	7.20077-10 ⁻⁴	7.20077-10 ⁻²	72.0077	1	5.20833-10 ⁻³	6.250-10 ⁻²
ft-lbs	1.35582	1.35582-10 ²	1.35582-10 ⁷	0.1382548	13.82548	1.382548-10 ⁴	192	1	12
in-lbs	0.112085	11.2985	1.12985-10 ⁶	1.15212-10 ⁻²	1.15212	1.15212-10 ³	16	8.33333-10 ⁻²	1

Densities of Common Materials

Material	oz/in ³	gm/cm ³
Aluminum (cast or hard-drawn)	1.54	2.66
Brass (cast or rolled 60% CU; 40% Zn)	4.80	8.30
Bronze (cast, 90% CU; 10% Sn)	4.72	8.17
Copper (cast or hand-drawn)	5.15	8.91
Plastic	0.64	1.11
Steel (hot or cold rolled, 0.2 or 0.8% carbon)	4.48	7.75
Hard Wood	0.46	0.80
Soft Wood	0.28	0.48

Calculate Horsepower

$$\text{Horsepower} = \frac{\text{Torque} \times \text{Speed}}{16,800}$$

$$\text{Torque} = \text{oz-in}$$

$$\text{Speed} = \text{revolutions per second}$$

* The horsepower calculation uses the torque available at the specified speed

$$1 \text{ Horsepower} = 746 \text{ watts}$$

Most tables give densities in lb/ft³. To convert to oz/in³ divide this value by 108. To convert lb/ft³ to gm/cm³ divide by 62.5. The conversion from oz/in³ to gm/cm³ is performed by multiplying oz/in³ by 1.73.

Reference: *Elements of Strength of Materials*, S. Timoshenko and D.H. Young, pp. 342-343.

Summary of Application Examples

Feed-to-length

Applications in which a continuous web, strip, or strand of material is being indexed to length, most often with pinch rolls or some sort of gripping arrangement. The index stops and some process occurs (cutting, stamping, punching, labeling, etc.).

Application No.	Page
1: BBQ Grill-Making Machine	A73
2: Film Advance	A74
3: On-the-Fly Welder	A75

X/Y Point-to-point

Applications that deal with parts handling mechanisms that sort, route, or divert the flow of parts.

Application No.	Page
4: Optical Scanner	A76
5: Circuit Board Scanning	A77

Metering/Dispensing

Applications where controlling displacement and/or velocity are required to meter or dispense a precise amount of material.

Application No.	Page
6: Telescope Drive	A78
7: Engine Test Stand	A79
8: Capsule Filling Machine	A80

Indexing/Conveyor

Applications where a conveyor is being driven in a repetitive fashion to index parts into or out of an auxiliary process.

Application No.	Page
9: Indexing Table	A81
10: Rotary Indexer	A82
11: Conveyor	A83

Contouring

Applications where multiple axes of motion are used to create a controlled path, (e.g., linear or circular interpolation).

Application No.	Page
12: Engraving Machine	A84
13: Fluted-Bit Cutting Machine	A85

Tool Feed

Applications where motion control is used to feed a cutting or grinding tool to the proper depth.

Application No.	Page
14: Surface Grinding Machine	A86
15: Transfer Machine	A87
16: Flute Grinder	A88
17: Disc Burnisher	A89

Winding

Controlling the process of winding material around a spindle or some other object.

Application No.	Page
18: Monofilament Winder	A90
19: Capacitor Winder	A91

Following

Applications that require the coordination of motion to be in conjunction with an external speed or position sensor.

Application No.	Page
20: Labelling Machine	A92
21: Window Blind Gluing	A93
22: Moving Positioning Systems	A94

Injection Molding

Applications where raw material is fed by gravity from a hopper into a pressure chamber (die or mold). The mold is filled rapidly and considerable pressure is applied to produce a molded product.

Application No.	Page
23: Plastic Injection Molding	A95

Flying Cutoff

Applications where a web of material is cut while the material is moving. Typically, the cutting device travels at an angle to the web and with a speed proportional to the web.

Application No.	Page
24: Rotating Tube Cutting	A96

1. BBQ Grill-Making Machine

Application Type: Feed-to-Length

Motion: Linear

Application Description: A manufacturer was using a servo motor to feed material into a machine to create barbeque grills, shopping carts, etc. The process involves cutting steel rods and welding the rods in various configurations. However, feed-length was inconsistent because slippage between the drive roller and the material was too frequent. Knurled nip-rolls could not be used because they would damage the material. The machine builder needed a more accurate method of cutting the material at uniform lengths. The customer used a load-mounted encoder to provide feedback of the actual amount of material fed into the cutting head.

Machine Objectives:

- Compensate for material slippage
- Interface with customer's operator panel
- Smooth repeatable operation
- Variable length indexes
- High reliability

Motion Control Requirements:

- Accurate position control
- Load-mounted encoder feedback
- High-speed indexing
- XCode language

Application Solution: By using the global position feedback capability of the BLHX drive, the machine builder was able to close the position loop with the load-mounted encoder, while the velocity feedback was provided by the motor-mounted encoder and signal processing. The two-encoder system provides improved stability and higher performance than a single load-mounted encoder providing both position and velocity feedback. The load-mounted encoder was coupled to friction drive nip-rollers close to the cut head.

Product Solutions:

Controller/Drive	Motor
BLHX75BN	ML3450B-10

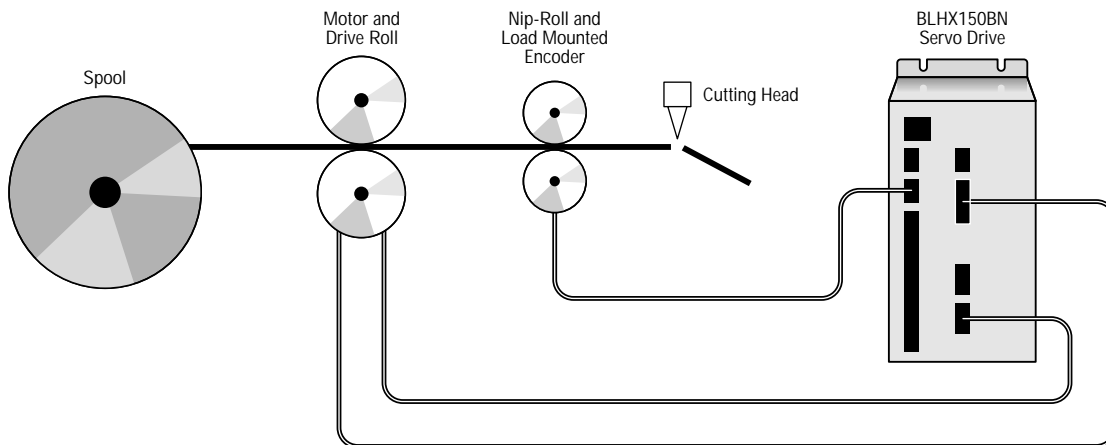

2. Film Advance

Application Type: Feed-to-Length

Motion: Linear

Tangential drives consist of a pulley or pinion which, when rotated, exerts a force on a belt or racks to move a linear load. Common tangential drives include pulleys and cables, gears and toothed belts, and racks and pinions.

Tangential drives permit a lot of flexibility in the design of drive mechanics, and can be very accurate with little backlash. Metal chains should be avoided since they provide little or no motor damping.

Application Description: A movie camera is being modified to expose each frame under computer control for the purpose of generating special effects. A motor will be installed in the camera connected to a 1/2-inch diameter, 2-inch long steel film drive sprocket and must index one frame in 200 milliseconds. The frame spacing is 38 mm (1.5").

Machine Requirements:

- Index one frame within 200 milliseconds
- Indexer must be compatible with BCD interface
- Fast rewind and frame indexing

Motion Control Requirements:

- Little to no vibration at rest—∴ Stepper
- Minimum settling time
- Preset and slew moves

Application Solution:

In this application, the move distance and time are known, but the required acceleration is not known. The acceleration may be derived by observing that, for a trapezoidal move profile with equal acceleration, slew and deceleration times, 1/3 of the move time is spent accelerating and 1/3 of the total distance is travelled in that time (a trapezoidal move).

It is determined that the acceleration required is 107.4 rps² at a velocity of 7.166 rps. Assume that the film weighs 1 oz. and total film friction is 10 oz-in. The rotor, sprocket, and film inertia is calculated to be 0.545 oz-in/sec². Solving the torque formula indicates that the motor for this application must provide 11.9 oz-in to drive the film and pulley (refer to Direct Drive Formulas on p. A63).

An indexer is selected to be connected to a BCD interface in the camera electronics. Preset and Slew modes on the indexer are then controlled by the camera electronics to provide fast rewind and frame indexing.

Product Solutions:

Drive/Indexer	Motor
SX	S57-51-MO

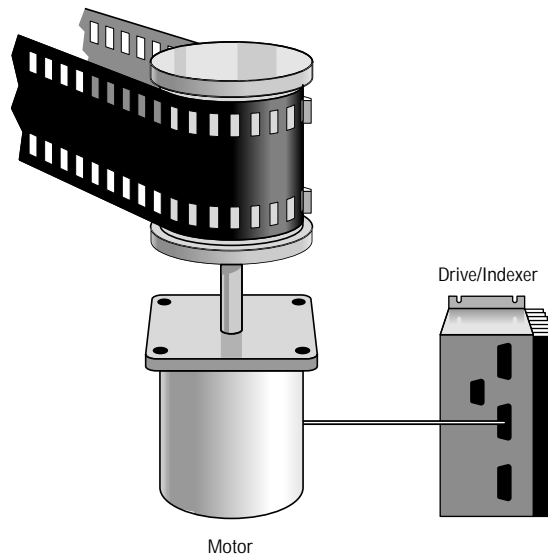

3. On-the-Fly Welder

Application Type: Feed-to-Length

Motion: Linear

Description: In a sheet metal fabrication process, an unfastened part rides on a conveyor belt moving continuously at an unpredictable velocity. Two spot-welds are to be performed on each part, 4 inches apart, with the first weld 2 inches from the leading edge of the part. A weld takes one second.

Machine Objectives

- Standalone operation
- Position welder according to position and velocity of each individual part
- Welding and positioning performed without stopping the conveyor
- Welding process must take 1 second to complete

Motion Control Requirements

- Programmable I/O; sequence storage
- Following
- Motion profiling; complex following
- High linear acceleration and speed

Application Solution:

This application requires a controller that can perform following or motion profiling based on a primary encoder position. In this application, the controller will receive velocity and position data from an incremental encoder mounted to a roller on the conveyor belt carrying the unfastened parts. The conveyor is considered the primary drive system. The secondary motor/drive system receives instructions from the controller, based on a ratio of the velocity and position information supplied by the primary system encoder. The linear motor forcer carries the weld head and is mounted on an overhead platform in line with the conveyor.

Linear motor technology was chosen to carry the weld head because of the length of travel. The linear step motor is not subject to the same linear velocity and acceleration limitations inherent in systems converting rotary to linear motion. For

example, in a leadscrew system, the inertia of the leadscrew frequently exceeds the inertia of the load and as the length of the screw increases, so does the inertia. With linear motors, all the force generated by the motor is efficiently applied directly to the load; thus, length has no effect on system inertia. This application requires a 54-inch platen to enable following of conveyor speeds over 20 in/sec.

Application Process

1. A sensor mounted on the weld head detects the leading edge of a moving part and sends a trigger pulse to the controller.
2. The controller receives the trigger signal and commands the linear motor/drive to ramp up to twice the speed of the conveyor. This provides an acceleration such that 2 inches of the part passes by the weld head by the time the weld head reaches 100% of the conveyor velocity.
3. The controller changes the speed ratio to 1:1, so the weld head maintains the speed of the conveyor for the first weld. The weld takes 1 second.
4. The following ratio is set to zero, and the welder decelerates to zero velocity over 2 inches.
5. The controller commands the linear forcer to repeat the same acceleration ramp as in step 1 above. This causes the weld head to position itself, at an equal velocity with the conveyor, 4 inches behind the first weld.
6. Step 3 is repeated to make the second weld.
7. Once the second weld is finished, the controller commands the linear forcer to return the weld head to the starting position to wait for the next part to arrive.

Product Solutions:

Indexer	Drive	Motor	Encoder
Model 500	L Drive	PO-L20-P54	-E

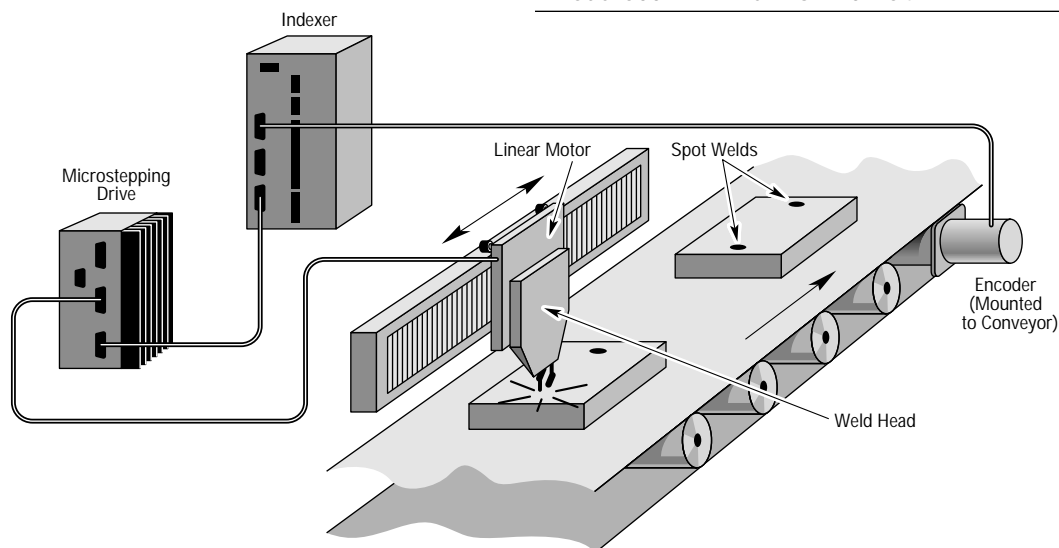

4. Optical Scanner

Application Type: X-Y Point-to-Point

Motion: Rotary

Application Description: A dye laser designer needs to precisely rotate a diffraction grating under computer control to tune the frequency of the laser. The grating must be positioned to an angular accuracy of 0.05° . The high resolution of the microstepping motor and its freedom from "hunting" or other unwanted motion when stopped make it ideal.

Machine Requirements:

- System must precisely rotate a diffraction grating to tune the frequency of the laser
- PC-compatible system control
- Angular accuracy of 0.05°
- IEEE-488 interface is required

Motion Control Requirements:

- High resolution—∴ Microstepper
- Little to no vibration at rest—∴ Stepper
- No "hunting" at the end of move—∴ Stepper
- Limited space is available for motor—∴ small motor is required

Application Solution:

The inertia of the grating is equal to 2% of the proposed motor's rotor inertia and is therefore ignored. Space is at a premium in the cavity and a small motor is a must. A microstepping motor, which provides ample torque for this application, is selected.

The laser's instrumentation is controlled by a computer with an IEEE-488 interface. An indexer with an IEEE-488 interface is selected. It is mounted in the rack with the computer and is controlled with a simple program written in BASIC that instructs the indexer to interrupt the computer at the completion of each index.

Product Solutions:

Indexer	Drive	Motor
Model 4000	LN Drive	LN57-51

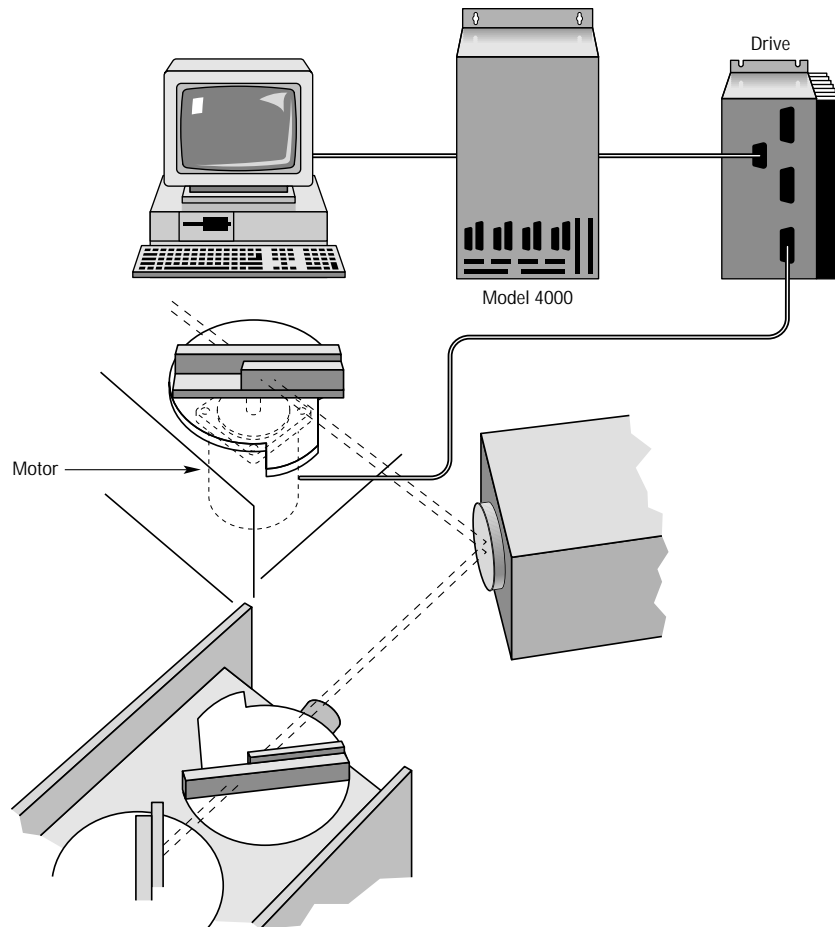

5. Circuit Board Scanning

Application Type: X-Y Point-to-Point

Motion: Linear

Application Description: An Original Equipment Manufacturer (OEM) manufactures X-Ray Scanning equipment used in the quality control of printed circuit boards and wafer chips.

The OEM wants to replace the DC motors, mechanics and analog controls with an automated PC-based system to increase throughput and eliminate operator error. The host computer will interact with the motion control card using a "C" language program. The operator will have the option to manually override the system using a joystick.

This machine operates in an environment where PWM (pulse width modulation) related EMI emission is an issue.

Machine Requirements:

- 2-Axis analog joystick
- Joystick button
- Travel limits
- Encoder feedback on both axes

Display Requirements:

- X and Y position coordinates

Operator Adjustable Parameters:

- Dimensions of sample under test
- (0,0) position—starting point

Motion Control Requirements:

- AT-based motion controller card
- Replace velocity control system (DC motors) and mechanics with more accurate and automated positioning scheme
- Manual Joystick control
- Continuous display of X & Y axis position
- User-friendly teach mode operations
- Low EMI amplifiers (drives)

Application Solution:

The solution of this application uses the existing PC by providing a PC-based motion controller and

the AT6400 to control both axes. A microstepping drive is used because its linear amplifier technology produces little EMI. The PC monitor is the operator interface.

A "C" language program controls the machine.

Machine operation begins with a display to the operator of a main menu. This main menu lets the operator select between three modes: Automated Test, Joystick Position and Teach New Automated Test.

In Automated Test mode, the PC displays a menu of preprogrammed test routines. Each of these programs has stored positions for the different test locations. This data is downloaded to the controller when a test program is selected. The controller controls the axes to a home position, moves to each scan position, and waits for scan completion before moving to the next position.

In Joystick Position mode, the controller enables the joystick allowing the operator to move in both X and Y directions using the joystick. The AT6400 waits for a signal from the PC to indicate that the joystick session is over.

When Teach mode is selected, the PC downloads a teach program to the controller (written by the user). After the axes are homed, the controller enables the joystick and a "position select" joystick button. The operator then jogs axes to a position and presses the "position select" button. Each time the operator presses this "position select" button, the motion controller reads this position into a variable and sends this data to the PC for memory storage. These new position coordinates can now be stored and recalled in Automated Test mode.

Product Solutions:

Controller	Drive	Motor	Accessories
AT6400-AUX1	LN Drive	LN57-83-MO	-E Daedal X-Y Table Joystick

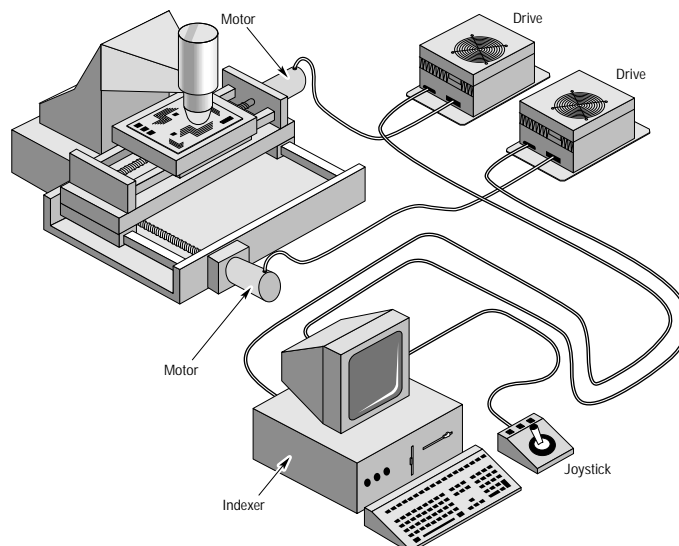

6. Telescope Drive

Application Type: Metering/Dispensing

Motion: Rotary

Traditional gear drives are more commonly used with step motors. The fine resolution of a microstepping motor can make gearing unnecessary in many applications. Gears generally have undesirable efficiency, wear characteristics, backlash, and can be noisy.

Gears are useful, however, when very large inertias must be moved because the inertia of the load reflected back to the motor through the gearing is divided by the square of the gear ratio.

In this manner large inertial loads can be moved while maintaining a good load inertia-to-rotor inertia ratio (less than 10:1).

Application Description: An astronomer building a telescope needs to track celestial events at a slow speed (15°/hour) and also slew quickly (15° in 1 second).

Machine Requirements:

- Smooth, slow speed is required—∴ microstepper
- High data-intensive application—∴ bus-based indexer
- Future capabilities to control at least 2 axes of motion
- Visual C++ interface

Motion Control Requirements:

- High resolution
- Very slow speed (1.25 revolutions per hour)—microstepping
- AT bus-based motion controller card
- Dynamic Link Library (DDL) device driver must be provided with indexer. This helps Windows™ programmers create Windows-based applications (i.e., Visual C++) to interface with the indexer

Application Solution:

A 30:1 gearbox is selected so that 30 revolutions of the motor result in 1 revolution (360°) of the telescope. A tracking velocity of 15°/hour corresponds to a motor speed of 1.25 revs/hour or about 9 steps/sec. on a 25,000 steps/rev. Moving 15° (1.25 revolutions) in 1 second requires a velocity of 1.25 rps.

The inverse square law causes the motor to see 1/900 of the telescope's rotary inertia. The equations are solved and the torque required to accelerate the telescope is 455 oz-in. The step pulses required to drive the motor are obtained from a laboratory oscillator under the operator's control.

Product Solutions:

Indexer	Drive	Motor
AT6200-AUX1*	S Drive	S106-178

* To control up to four axes, refer to the AT6400.

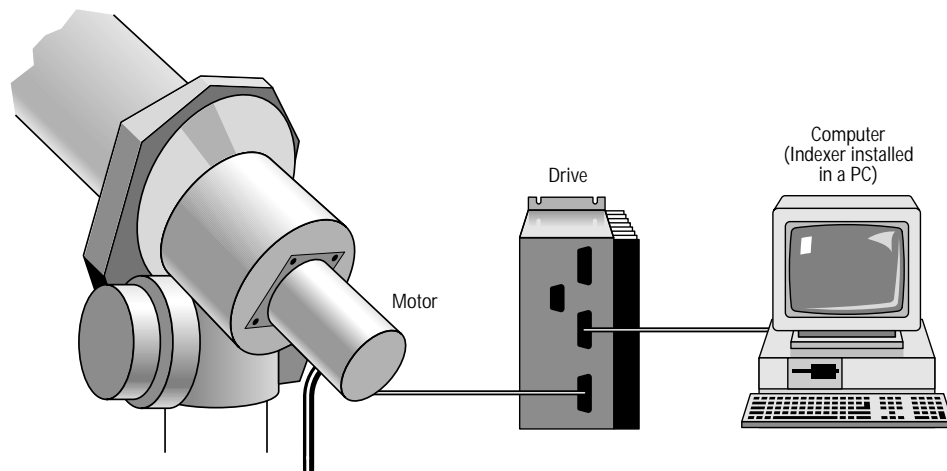

7. Engine Test Stand

Application Type: Metering/Dispensing

Motion: Rotary

Application Description: A jet engine manufacturer is building a test facility for making operational measurements on a jet engine. The throttle and three other fuel flow controls need to be set remotely. While the application only calls for a rotary resolution of 1 degree (1/360 rev.), the smoothness and stiffness of a microstepping system is required.

Motor speeds are to be low and the inertias of the valves connected to the motors are insignificant. The main torque requirement is to overcome valve friction.

Machine Requirements:

- Low wear
- Remote operation
- High reliability

Motion Control Requirements:

- Motor velocity is low
- High stiffness at standstill
- Slow-speed smoothness
- Four axes of control
- Homing function

Application Solution:

Each valve is measured with a torque wrench. Two valves measure at 60 oz-in and the other two measure at 200 oz-in. Two high-power and two low-power microstepping motor/drives systems are selected. These choices provide approximately 100% torque margin and result in a conservative design.

The operator would like to specify each valve position as an angle between 0° and 350°.

Home position switches are mounted on the test rig and connected to each indexer to allow for power-on home reference using the indexer's homing feature.

Product Solutions:

Indexer	Drive	Motor
AT6400*	S Drive	S57-102

* A standalone indexer could also be used (instead of a bus-based indexer), refer to the Model 4000.

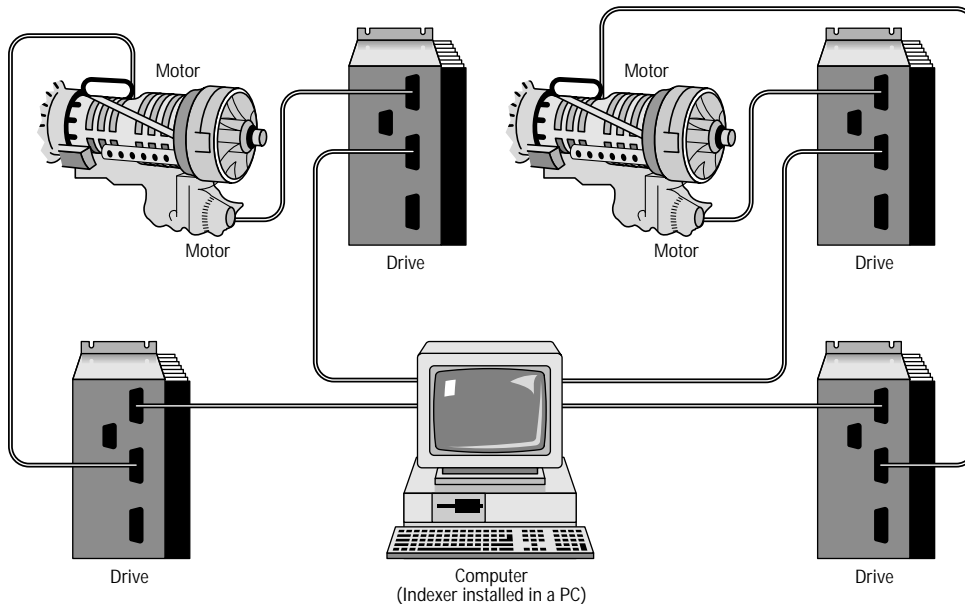

8. Capsule Filling Machine

Application Type: Metering/Dispensing

Motion: Linear

Application Description: The design requires a machine to dispense radioactive fluid into capsules. After the fluid is dispensed, it is inspected and the data is stored on a PC. There is a requirement to increase throughput without introducing spillage.

Machine Requirements:

- Increase throughput
- No spilling of radioactive fluid
- Automate two axes
- PC compatible system control
- Low-cost solution
- Smooth, repeatable motion

Motion Control Requirements:

- Quick, accurate moves
- Multi-axis controller
- PC bus-based motion control card
- Open-loop stepper if possible
- High-resolution motor/drive (microstepping)

Application Solution:

The multi-axis indexer is selected to control and synchronize both axes of motion on one card residing in the IBM PC computer. An additional feature is the integral I/O capability that's necessary to activate the filling process. The horizontal axis carrying the tray of capsules is driven by a linear motor. The simple mechanical construction of the motor makes it easy to apply, and guarantees a long maintenance-free life. The vertical axis raises and lowers the filling head and is driven by a microstepping motor and a leadscrew assembly. A linear motor was also considered for this axis, but the fill head would have dropped onto the tray with a loss of power to the motor. Leadscrew friction and the residual torque of the step motor prevents this occurrence.

Product Solutions:

Indexer	Drive	Motor
AT6200	Axis 1: ZETA Drive Axis 2: ZETA Drive	S57-51 PO-L20-P18

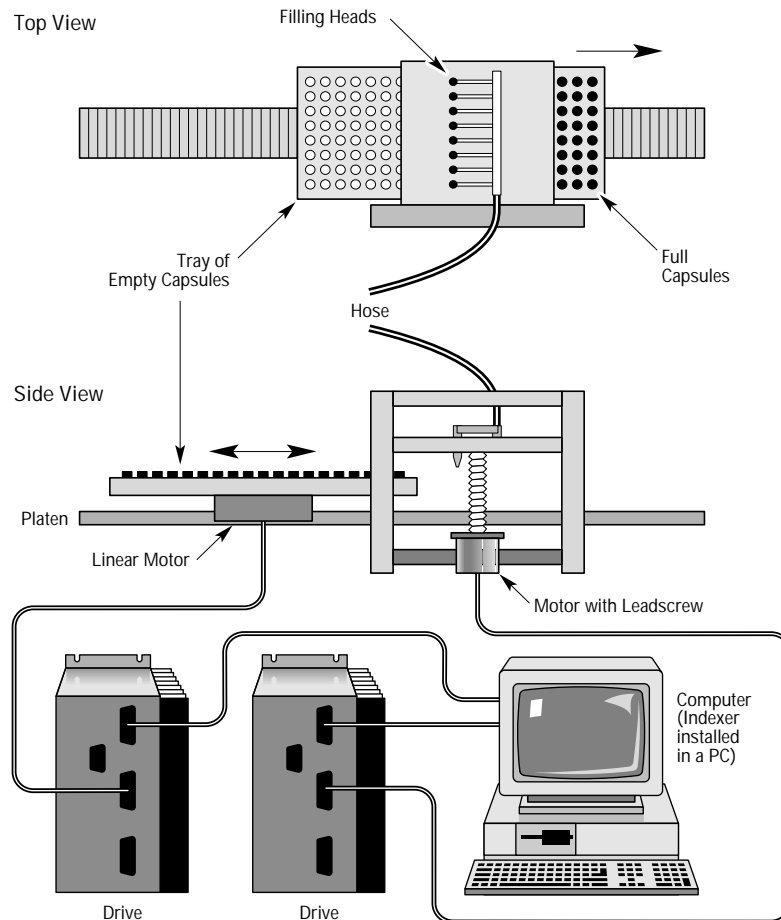

9. Indexing Table

Application Type: Indexing/Conveyor

Motion: Linear

Application Description: A system is required to plot the response of a sensitive detector that must receive equally from all directions. It is mounted on a rotary table that needs to be indexed in 3.6° steps, completing each index within one second. For set-up purposes, the table can be positioned manually at 5 rpm. The table incorporates a 90:1 worm drive.

Machine Requirements:

- Low-EMI system
- Repeatable indexing
- Remote operation
- Table speed of 5 rpm

Motion Control Requirements:

- Jogging capability
- Sequence select functionality
- Capable of remote drive shutdown

Application Solution:

The maximum required shaft speed (450 rpm) is well within the capability of a stepper, which is an ideal choice in simple indexing applications. Operating at a motor resolution of 400 steps/rev, the resolution at the table is a convenient 36,000 step/rev. In this application, it is important that electrical noise is minimized to avoid interference with the detector. Two possible solutions are to use a low-EMI linear drive or to shut down the drive after each index (with a stepper driving a 90:1 worm gear there is no risk of position loss during shutdown periods).

Product Solutions:

Indexer	Drive	Motor
Model 500	LN Drive	LN57-102

* The SX drive/indexer and PK2 drive are other products that have been used in these types of applications.

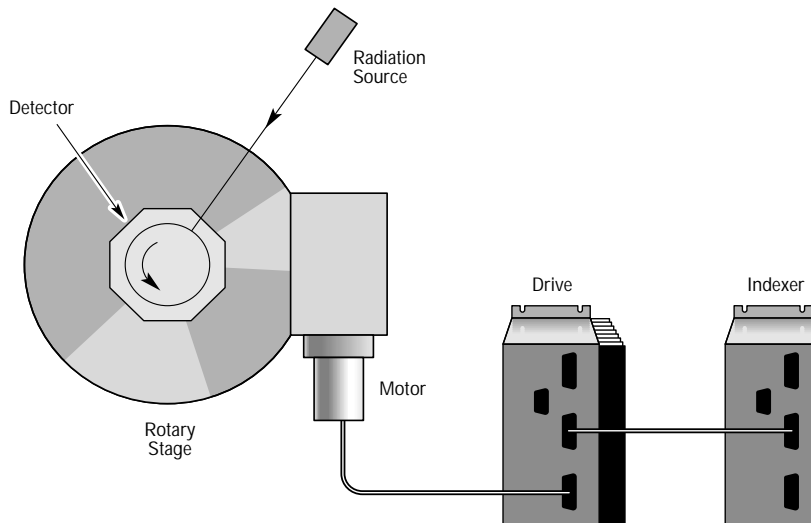

10. Rotary Indexer

Application Type: Indexing Conveyor

Motion: Rotary

Application Description: An engineer for a pharmaceutical company is designing a machine to fill vials and wants to replace an old style Geneva mechanism. A microstepping motor will provide smooth motion and will prevent spillage.

The indexing wheel is aluminum and is 0.250-inch thick and 7.5" in diameter. Solving the equation for the inertia of a solid cylinder indicates that the wheel has 119.3 oz-in². The holes in the indexing wheel reduce the inertia to 94 oz-in². The vials have negligible mass and may be ignored for the purposes of motor sizing. The table holds 12 vials (30° apart) that must index in 0.5 seconds and dwell for one second. Acceleration torque is calculated to be 8.2 oz-in at 1.33 rps². A triangular move profile will result in a maximum velocity of 0.33 rps. The actual torque requirement is less than 100 oz-in. However, a low load-to-rotor inertia ratio was necessary to gently move the vials and fill them.

Machine Requirements:

- Smooth motion
- PLC control
- Variable index lengths

Motion Control Requirements:

- Smooth motion
- Sequence select capability
- I/O for sequence select
- Programmable acceleration and deceleration

Application Solution:

The index distance may be changed by the engineer who is controlling the machine with a programmable controller. Move parameters will be changing and can therefore be set via BCD inputs. The indexer can be "buried" in the machine and activated with a remote START input.

Product Solutions:

Drive Indexer	Motor
SX Drive Indexer*	S83-135

* The 6200, AT6200, and Model 500 are other indexer products that have been used in these types of applications.

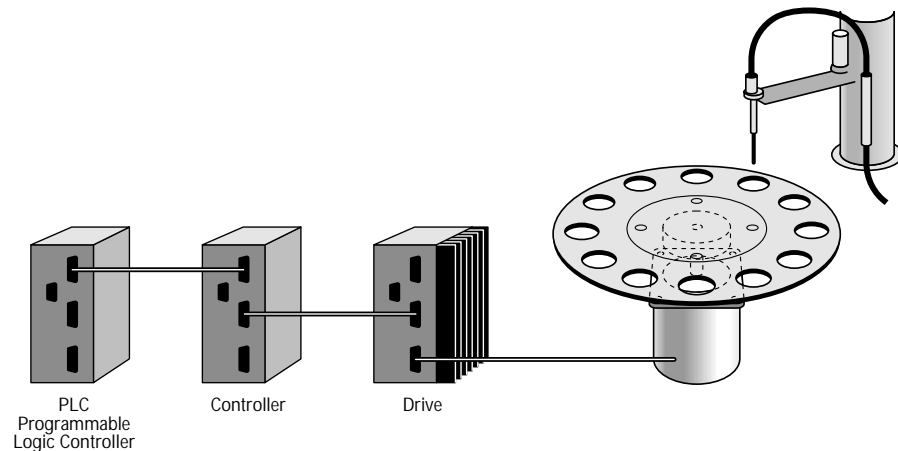

11. Conveyor

Application Type: Indexing/Conveyor

Motion: Linear

Tangential drives consist of a pulley or pinion which, when rotated, exerts a force on a belt or racks to move a linear load. Common tangential drives include pulleys and cables, gears and toothed belts, and racks and pinions.

Tangential drives permit a lot of flexibility in the design of drive mechanics, and can be very accurate with little backlash. Metal chains should be avoided since they provide little or no motor damping.

Application Description: A machine vision system is being developed to automatically inspect small parts for defects. The parts are located on a small conveyor and pass through the camera's field of view. The conveyor is started and stopped under computer control and the engineer wants to use a system to drive the conveyor because it is necessary for the part to pass by the camera at a constant velocity.

It is desired to accelerate the conveyor to a speed of 20 inches/sec. in 100 milliseconds. A flat timing belt weighing 20 ozs. is driven by a 2-inch diameter aluminum pulley 4 inches wide (this requires a motor velocity of 3.2 rps). The maximum weight of the parts on the pulley at any given time is 1 lb. and the load is estimated to have an inertia of 2 oz-in². Static friction of all mechanical components is 30 oz-in. The required motor torque was determined to be 50.9 oz-ins (refer to Direct Drive Formulas on p. A63).

Machine Requirements:

- Computer-controlled system
- High accuracy
- Low backlash

Motion Control Requirements:

- Accurate velocity control
- Linear motion
- High resolution
- AT bus-based motion control card

Application Solution:

A computer controls the entire inspection machine. A bus-based compatible indexer card was selected. A microstepping motor/drive system that supplied 100 oz-in of static torque was also chosen to complete the application.

Product Solutions:

Indexer	Drive	Motor
PC21*	S Drive	S57-83

* The AT6200 and AT6400 are other PC-based indexer products that are often used in these types of applications.

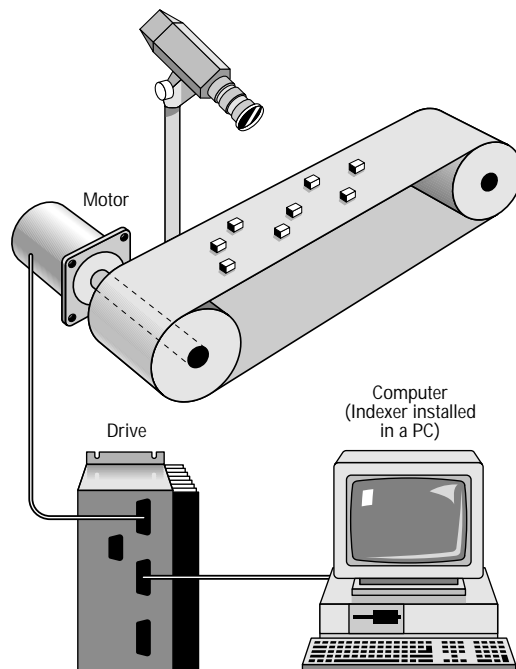

Application Examples

12. Engraving Machine

Application Type: Contouring

Motion: Linear

Application Description: An existing engraving machine requires an upgrade for accuracy beyond 0.008 inches, capability and operating environment. Using a personal computer as the host processor is desirable.

Machine Requirements:

- Positional accuracy to 0.001 inches
- Easy-to-use, open-loop control
- CNC machining capability
- Interface-to-digitizer pad
- Compatibility with CAD systems

Motion Control Requirements:

- High resolution
- Microstepping
- G-Code compatibility
- IBM PC compatible controller

Application Solution:

A four-axis motion controller resides on the bus of an IBM compatible computer, allowing full integrated control of four axes of motion. Axes 3 and 4 are synchronized to prevent table skew. CompuCAM's G-Code package allows the user to program in industry-standard machine tool language (RS274 G-Code) or to import CAD files with CompuCAM-DXF. Open-loop microstepping drives with precision leadscrews give positional accuracies better than the desired ± 0.001 inch. This simple retrofit to the existing hardware greatly improved system performance.

Product Solutions:

Indexer	Drives	Motor
AT6400*	S Drives	S83-135

* The Model 4000 (standalone) and AT6450 are servo controller products that have also been used in these types of applications.

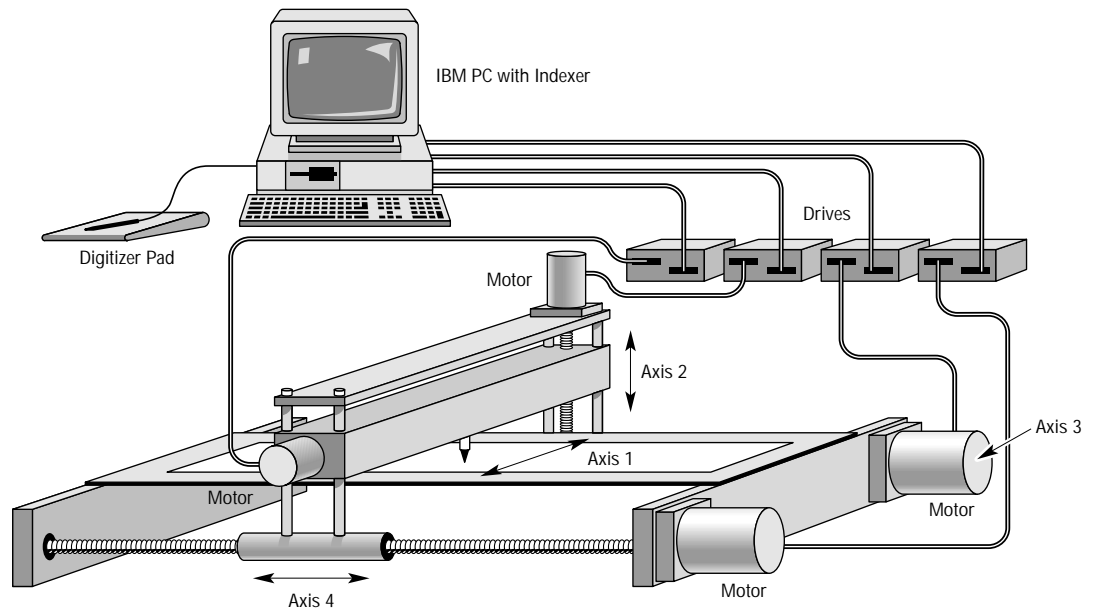

13. Fluted-Bit Cutting Machine

Application Type: Contouring

Motion: Linear

Application Description: The customer manufactures a machine that cuts a metal cylinder into fluted cutting bits for milling machines. The machine operation employed a mechanical cam follower to tie the bit's rotation speed to the traverse motion of the bit relative to the cutting tool. The cut depth was manually adjusted using a hand crank.

This arrangement was acceptable when the company had a bit for the cam they wanted to grind. Unfortunately, custom prototype bits made of titanium or other high-tech metals required that they make a cam before they could machine the bit, or do those parts on a \$10,000 CNC screw machine. Both of these alternatives were too expensive for this customer.

Machine Requirements:

- Machine must be capable of making low-volume custom bits as well as high-volume standard bits—an be economical for both processes.

- Quick set-up routine
- Operator interface for part entry

Motion Control Requirements:

- Smooth motion
- Four axes of coordinated motion
- 2 axes of linear interpolation
- Math capabilities

Application Solution:

Controlled by a multi-axis step and direction controller, microstepping motors and drives are attached to four axes for smooth, programmable motion at all speeds.

- Axis 1: Alignment
- Axis 2: Chamfer (cutting depth)
- Axis 3: Traverse
- Axis 4: Rotation

To allow for the flexibility required to cut a bit at a desired pitch, the traverse and rotation axes (axes 3 and 4) are synchronized along a straight line. The controller's linear interpolation allows this functionality. Both the alignment and chamfer axes (axes 1 and 2) remain stationary during the cutting process.

The controller's operator input panel and math capabilities allow the operator to enter the bit diameter, desired pitch, depth, and angle. Using these part specifications, the controller generates all motion profiles and stores them in nonvolatile battery-backed RAM. Programming is accomplished with the controller's menu-driven language. The typical process is as follows:

1. Axis 1 aligns the center line of the bit to the cutting tool.
2. Axis 2 lowers the cutting tool to the desired cutting depth (chamfer).
3. Axis 3 traverses the bit along the cutting tool.
4. While axis 3 traverses, axis 4 rotates the bit to create the desired pitch.

Product Solutions:

Indexer	Drives	Motor
Model 4000*	S Drives	S83-135

* The Model AT6400 and AT6450 are other controllers that have been used in these types of applications.

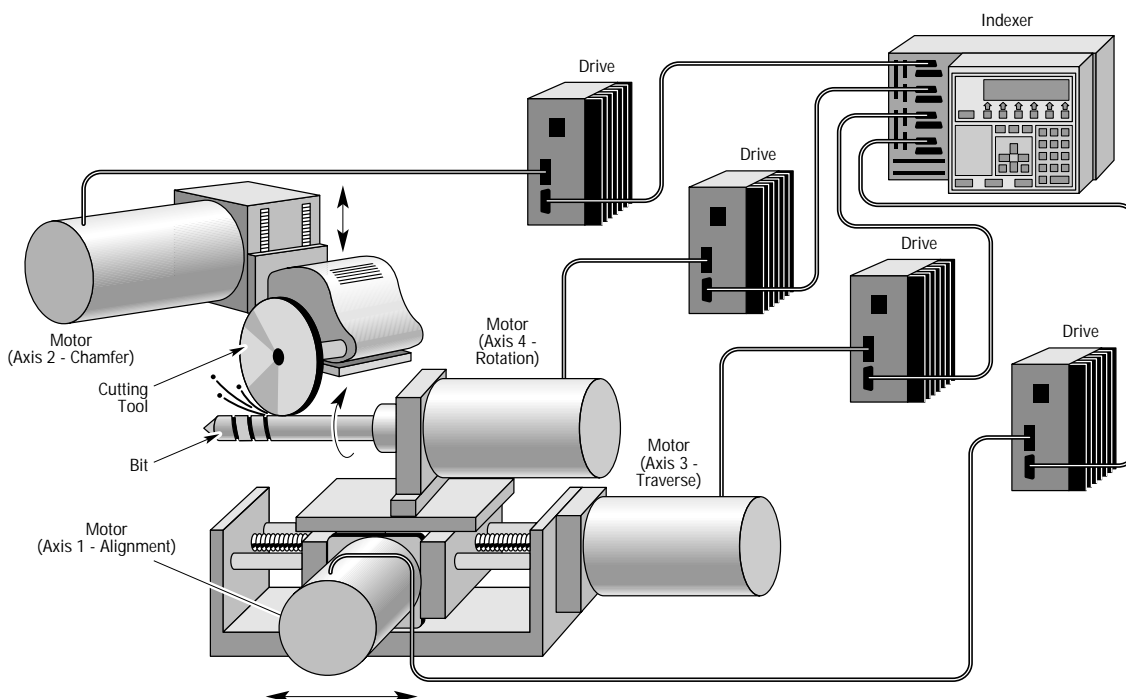

14. Surface Grinding Machine

Application Type: Tool Feed

Motion: Linear

Application Description: A specialty machine shop is improving the efficiency of its surface grinding process. The existing machine is sound mechanically, but manually operated. Automating the machine will free the operator for other tasks, which will increase overall throughput of the machine shop.

Machine Requirements:

- Allow flexibility to machine various parts
- Easy set up for new parts
- Automate all three axes
- Keep operator informed as to progress
- Low-cost solution
- High-resolution grinding

Motion Control Requirements:

- Nonvolatile memory for program storage
- Teach mode
- Multi-axis controller
- Interactive user configurable display
- Open-loop stepper if possible
- High resolution motor/drive (microstepping)

Application Solution:

A four-axis motion controller with a user-configurable front panel is required for this application. An indexer with a sealed, backlit display would be ideal for the application's industrial environment (machine shop). The controller's Teach mode and sizable nonvolatile memory allows for easy entry and storage of new part programs. Microstepping drives, which plenty of power, resolution, and accuracy are selected instead of more expensive closed-loop servo systems. The operator utilizes the controller's jog function to position the grinding head at the proper "spark off" height. From this point, the controller takes over and finishes the part while the operator works on other critical tasks. Increasing the parts repeatability and throughput of the process justified the cost of automating the machine.

Product Solutions:

Indexer	Drive	Motor
Model 4000*	S Drive	S83-93

* The AT6400 PC-based indexer has also been used to solve similar applications.

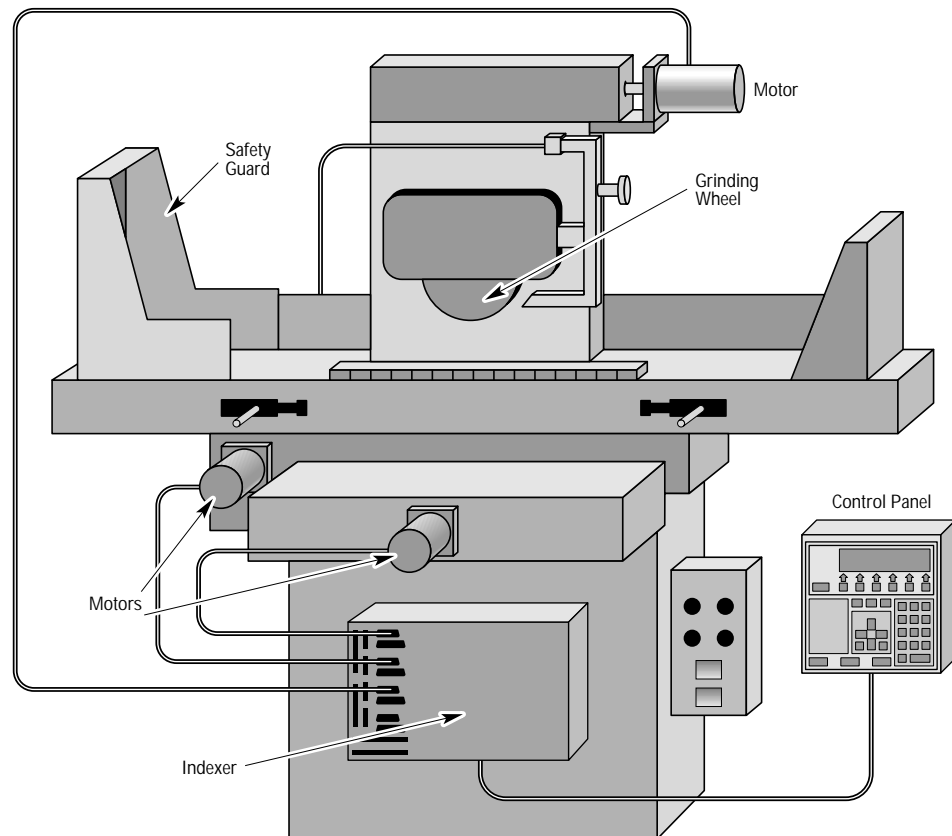

15. Transfer Machine

Application Type: Tool Feed

Motion: Linear

Application Description: A stage of a transfer machine is required to drill several holes in a casting using a multi-head drill. The motor has to drive the drill head at high speed to within 0.1" of the workpiece and then proceed at cutting speed to the required depth. The drill is then withdrawn at an intermediate speed until clear of the work, then fast-retracted and set for the next cycle. The complete drilling cycle takes 2.2 seconds with a 0.6-second delay before the next cycle.

Due to the proximity of other equipment, the length in the direction of travel is very restricted. An additional requirement is to monitor the machine for drill wear and breakage.

Machine Requirements:

- Limited length of travel
- Limited maintenance
- Monitor and minimize drill damage
- High-speed drilling

Motion Control Requirements:

- Packaged drive controller
- Complex motion profile
- High speed
- High duty cycle

Application Solution:

The combined requirements of high speed, high duty cycle and monitoring the drill wear all point to the use of a servo motor. By checking the torque load on the motor (achieved by monitoring drive current), the drilling phase can be monitored (an increased load during this phase indicates that the drill is broken).

This type of application will require a ballscrew drive to achieve high stiffness together with high speed. One way of minimizing the length of the mechanism is to attach the ballscrew to the moving stage and then rotate the nut, allowing the motor to be buried underneath the table. Since access for maintenance will then be difficult, a brushless motor should be selected.

Product Solutions:

Drive/Controller	Motor
APEX6152	606 Motor

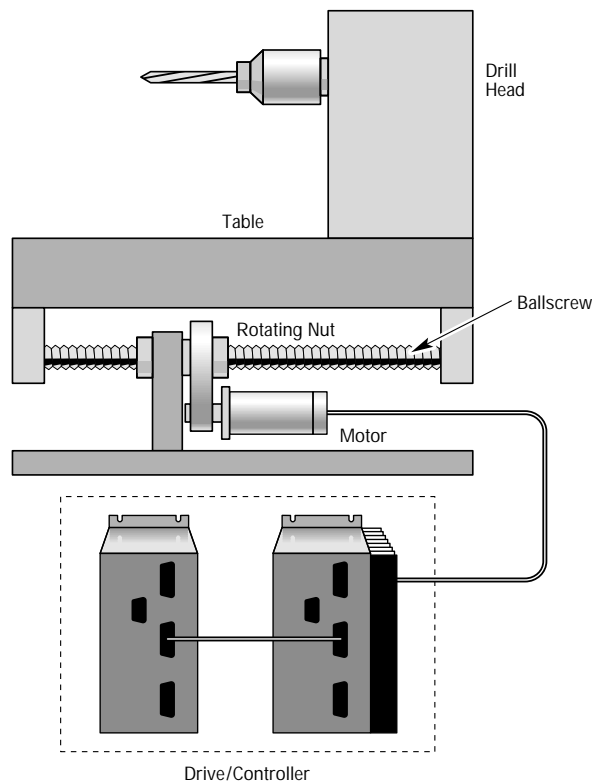

16. Flute Grinder

Application Type: Tool Feed

Motion: Linear

Application Description: A low-cost machine for grinding the flutes in twist drills requires two axes of movement—one moves the drill forwards underneath the grinding wheel, the other rotates the drill to produce the helical flute. At the end of the cut, the rotary axis has to index the drill round by 180° to be ready to grind the second flute. The linear speed of the workpiece does not exceed 0.5 inches/sec.

Machine Requirements:

- Two-axis control
- Low cost
- Easy set-up and change over of part programs
- Smooth, accurate cutting motion

Motion Control Requirements:

- Two-axis indexer
- Linear interpolation between axes
- Nonvolatile program storage
- Flexible data pad input
- Moderate speeds
- Programmable I/O

Application Solution:

This is a natural application for stepper motors, since the speeds are moderate and the solution must be minimum-cost. The grinding process requires that the two axes move at accurately related speed, so the controller must be capable of performing linear interpolation. The small dynamic position error of the stepper system ensures that the two axes will track accurately at all speeds.

Product Solutions:

Controller	Drive	Motor	Operator Interface
6200*	S Drive	S83-135	RP240

* The Model 4000-FP has also been used to solve similar applications.

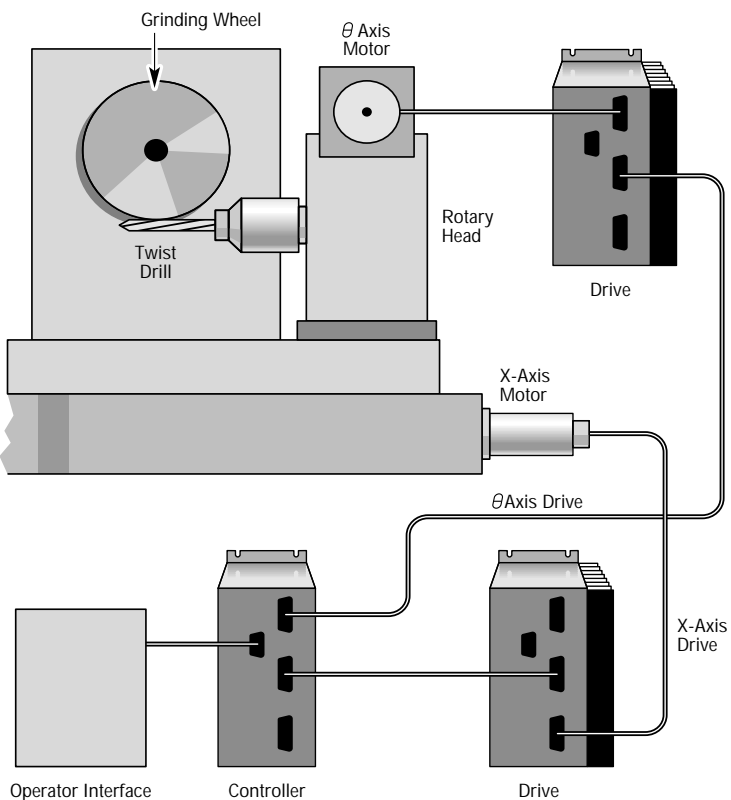

17. Disc Burnisher

Application Type: Tool Feed

Motion: Rotary

Application Description: Rigid computer discs need to be burnished so that they are flat to within tight tolerances. A sensor and a burnishing head move together radially across the disc. When a high spot is sensed, both heads stop while the burnishing head removes the raised material. The surface speed of the disc relative to the heads must remain constant, and at the smallest diameter, the required disc speed is 2400 rpm. The machine operates in a clean environment, and takes approximately one minute to scan an unblemished disk.

Machine Requirements:

- High-speed burnishing
- Surface speed of disc relative to the heads must remain constant
- Clean environment—∴ no brushed servo motors

Motion Control Requirements:

- Variable storage, conditional branching and math capabilities
- Linear interpolation between the head axes (axes #1 and #2)
- Change velocity on-the-fly
- Programmable inputs

Application Solution:

The drive for the disc requires continuous operation at high speed, and a brushless solution is desirable to help maintain clean conditions. The natural choice is a brushless servo system. The speed of this axis depends on head position and will need to increase as the heads scan from the outside to the center. To successfully solve this application, the multi-axis indexer requires variable storage, the ability to perform math functions, and the flexibility to change velocity on-the-fly.

The sense and burnishing heads traverse at low speed and can be driven by stepper motors. Stepper motors—since the sense and burnishing heads need to start and step at the same time, linear interpolation is required.

Product Solutions:

Controller	Drive #1	Drive #2	Drive #3
Model 4000*	S Drive	S Drive	Z Drive
	Motor #1	Motor #2	Motor #3
	S83-93	S83-93	Z60

* The AT6400 PC-based indexer has also been used in these types of applications.

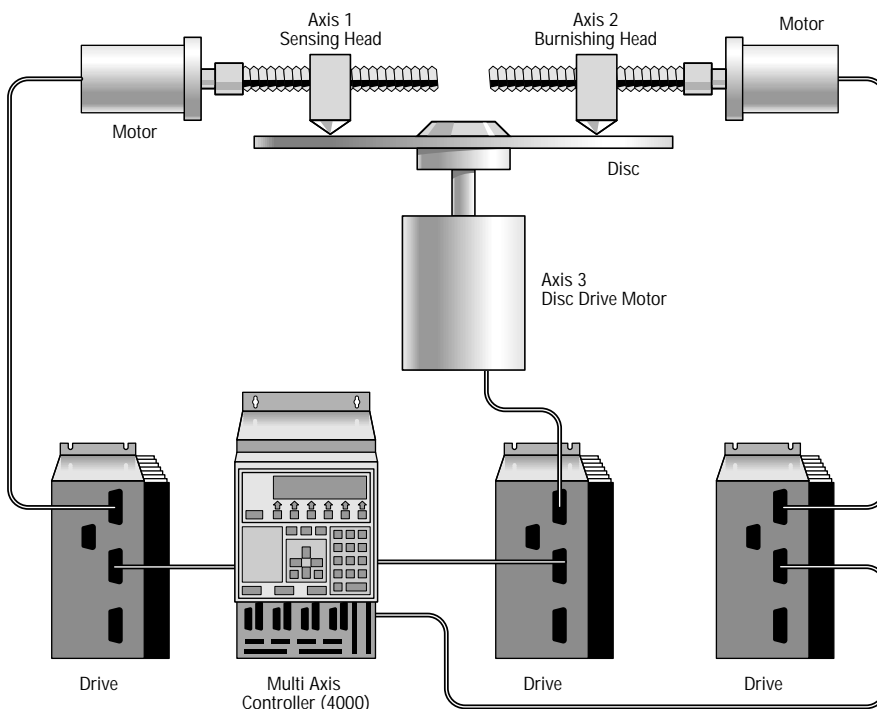

18. Monofilament Winder

Application Type: Winding

Motion: Rotary

Application Description: Monofilament nylon is produced by an extrusion process that results in an output of filament at a constant rate. The product is wound onto a bobbin that rotates at a maximum speed of 2000 rpm. The tension in the filament must be held between 0.2 lbs. and 0.6 lbs to ensure that it is not stretched. The winding diameter varies between 2" and 4".

The filament is laid onto the bobbin by a ballscrew-driven arm, which oscillates back and forth at constant speed. The arm must reverse rapidly at the end of the move. The required ballscrew speed is 60 rpm.

Machine Requirements:

- Controlled tension on monofilament
- Simple operator interface
- High throughput

Motion Control Requirements:

- 2 axes of coordinated motion
- Linear interpolation
- Constant torque from motor

Application Solution:

The prime requirement of the bobbin drive is to provide a controlled tension, which means operating in Torque mode rather than Velocity mode. If the motor produces a constant torque, the tension in the filament will be inversely proportional to the winding diameter. Since the winding diameter varies by 2:1, the tension will fall by 50% from start to finish. A 3:1 variation in tension is adequate, so constant-torque operation is acceptable. (To maintain constant tension, torque must be increased in proportion to winding diameter.)

This requirement leads to the use of a servo operating in torque mode (the need for constant-speed operation at 2000 rpm also makes a stepper unsuitable). In practice, a servo in Velocity mode might be recommended, but with an overriding torque limit, the programmed velocity would be a little more than 2000 rpm. In this way, the servo will normally operate as a constant-torque drive. However, if the filament breaks, the velocity would be limited to the programmed value.

The traversing arm can be adequately driven by a smaller servo.

Product Solutions:

Indexer	Drive	Motor
6250*	BL30	ML2340

* The AT6450 PC-based servo controller and the APEX20/APEX40 servo controllers have also been used in this type of application.

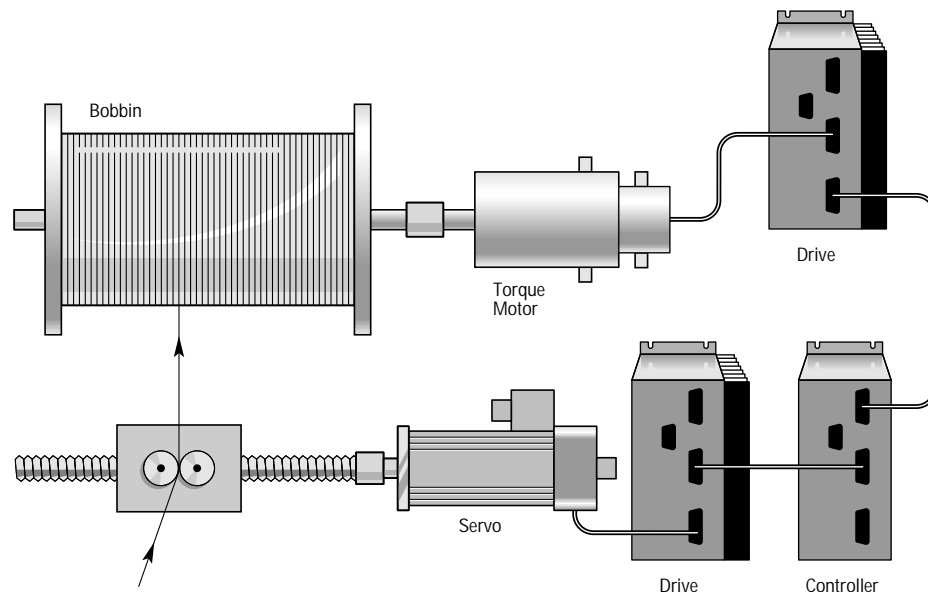

19. Capacitor Winder

Application Type: Winding

Motion: Linear

Application Description: The customer winds aluminum electrolytic capacitors. Six reels, two with foil (anode and cathode) and four with paper, are all wound together to form the capacitor. After winding the material a designated number of turns, the process is stopped and anode and cathode tabs are placed on the paper and foil. The tabs must be placed so that when the capacitor is wound, the tabs end up 90° (±0.1°) from each other. This process is repeated until the required number of tabs are placed and the capacitor reaches its appropriate diameter.

The previous system used a PLC, conventional DC drives, and counters to initiate all machine functions. DIP switches were used to change and select capacitor lengths. Lengthy set-up and calibration procedures were required for proper operation. In addition, material breakage was common, resulting in extensive downtime. An operator had to monitor the machine at all times to constantly adjust the distances for accurate tab placement.

Machine Requirements:

- Constantly monitor the linear feed length of the paper and foil and calculate the constantly changing capacitor circumference as a function of that length
- A complete motion control package is required to eliminate the need for a PLC and separate motion cards
- Reduce time and complexity of set-up (too much wiring in previous system)
- Reduce machine downtime caused by material breakage

Motion Control Requirements:

- Following
- Two axes of coordinated motion
- Math capability
- AT-based control card

Application Solution:

Precise motion control of the material feed axes demands closed-loop servo commands. Actuation of external cylinders and solenoids requires both analog and digital I/O. A flexible operator interface is needed for diagnostics and other alterations of machine function. Motion, I/O, and an operator interface should be provided with a machine controller.

The first motorized axis (mandril) pulls all six materials together and feeds an appropriate distance. An encoder is placed on this motor as well as on the materials as they are fed into the mandril. The controller constantly compares the two encoders to get an exact measurement of linear distance, and compensates for material stretching.

When the linear distance is achieved, the first motor comes to an abrupt stop while a second axis places a tab. The controller then initiates a cold weld (pressure weld) of the tab onto the paper and foil.

To avoid material breakage, constant tension is applied to each of the six reels via air cylinders. Sensors are installed on all axes so that if a break occurs, the controller can stop the process.

A computer makes this process easy to use and set up. PC/AT-based support software allows the user to build his controller command program.

The operator sets the diameter of the appropriate capacitor, the operating speed and the number of capacitors (all via the keyboard). After this process, the machine runs until a malfunction occurs or it has completed the job.

Product Solutions:

Controller	Drive	Motor	Accessories
AT6250*	BL30	ML2340	-E Encoder

* The 6250 standalone 2-axis servo controller and APEX20/APEX40 servo drives have also been used in these types of applications.

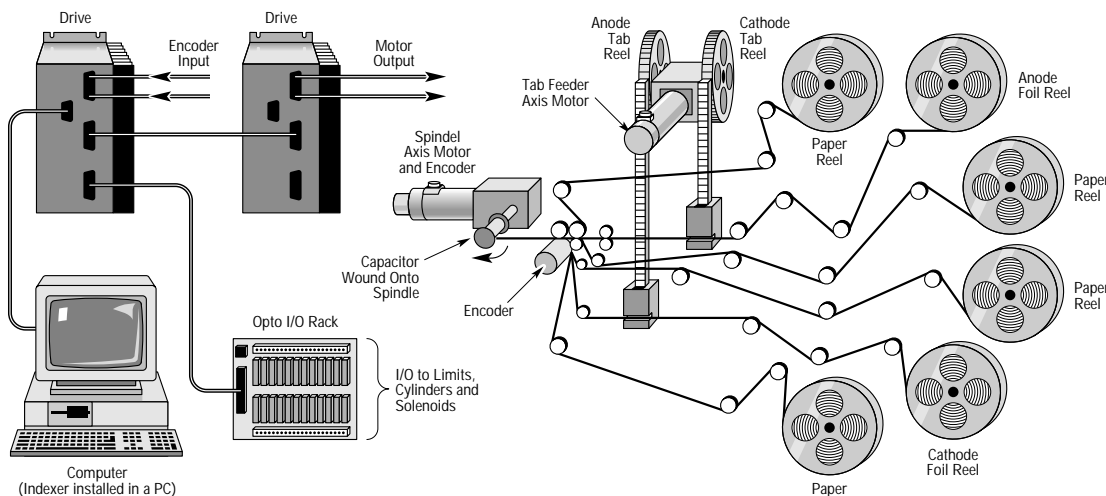

20. Labelling Machine

Application Type: Following

Motion: Linear

Application Description: Bottles on a conveyor run through a labelling mechanism that applies a label to the bottle. The spacing of the bottles on the conveyor is not regulated and the conveyor can slow down, speed up, or stop at any time.

Machine Requirements:

- Accurately apply labels to bottles in motion
- Allow for variable conveyor speed
- Allow for inconsistent distance between bottles
- Pull label web through dispenser
- Smooth, consistent labelling at all speeds

Motion Control Requirements:

- Synchronization to conveyor axis
- Electronic gearbox function
- Registration control
- High torque to overcome high friction
- High resolution
- Open-loop stepper if possible

Application Solution:

A motion controller that can accept input from an encoder mounted to the conveyor and reference all of the speeds and distances of the label roll to the encoder is required for this application. A servo system is also required to provide the torque and speed to overcome the friction of the dispensing head and the inertia of the large roll of labels. A photosensor connected to a programmable input on the controller monitors the bottles' positions on the conveyor. The controller commands the label motor to accelerate to line speed by the time the first edge of the label contacts the bottle. The label motor moves at line speed until the complete label is applied, and then decelerates to a stop and waits for the next bottle.

Product Solutions:

Controller	Motor
APEX6152*	APEX604

* The ZXF single-axis servo controller has also been used in these types of applications.

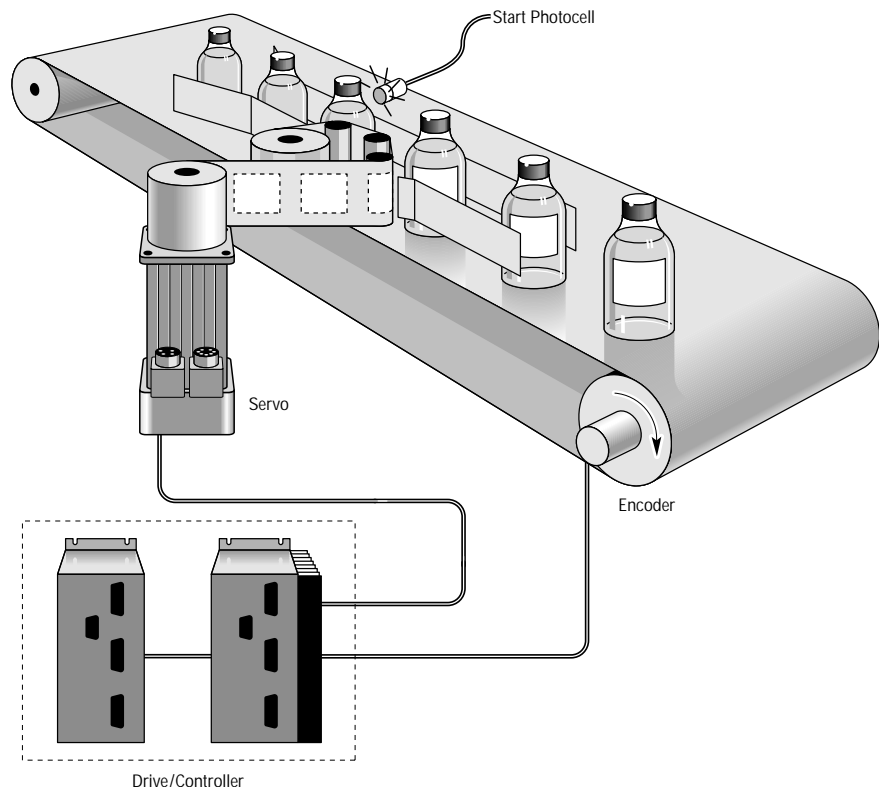
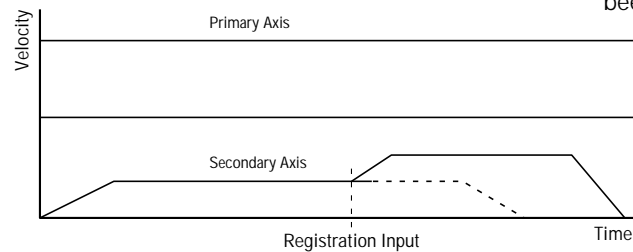

21. Window Blind Gluing

Application Type: Following

Motion: Linear

Application Description: A window blind manufacturer uses an adhesive to form a seam along the edge of the material. It is critical that the glue be applied evenly to avoid flaws; however, the speed that the material passes beneath the dispensing head is not constant. The glue needs to be dispensed at a rate proportional to the varying speed of the material.

Machine Requirements:

- Allow for varying material speed
- Dispense glue evenly

- Allow for multiple blind lengths

Motion Control Requirements:

- Synchronization to material speed
- Velocity following capabilities
- Sequence storage

Application Solution:

A step and direction indexer/follower and a microstepping motor/drive are used to power a displacement pump. The indexer/follower is programmed to run the motor/drive at a velocity proportional to the primary velocity of the material, based on input from a rotary incremental encoder. This assures a constant amount of glue along the length of the material.

When the start button is depressed, the glue will begin dispensing and can be discontinued with the stop button. If a new speed ratio is desired, FOR can be changed with either the front panel pushbutton, thumbwheels, or with the RS-232C serial link.

Program

Two following commands are used.

FOR Sets the ratio between the secondary motor resolution and the primary encoder resolution

FOL Sets the ratio of the speed between the primary and secondary motor

One input will be configured to start motion, a second input will be used to stop motion. The motor has 10000 steps/revolution. The encoder that is placed on the motor pulling the material has 4000 pulses/revolution. It is desired to have the motor dispensing the glue turning twice as fast as the encoder sensing the material.

FOR2.5 Set the motor to encoder ratio

FOL200 The following speed ratio is 200% or twice as fast

A10 Set acceleration to 10 rps²

AD10 Set deceleration to 10 rps²

MC The controller is placed in Continuous mode

Product Solutions:

Drive/Controller	Motor
SXF Drive/Controller*	S57-102

* The Model 500 single-axis controller and the S Drive have also been used in these types of applications.

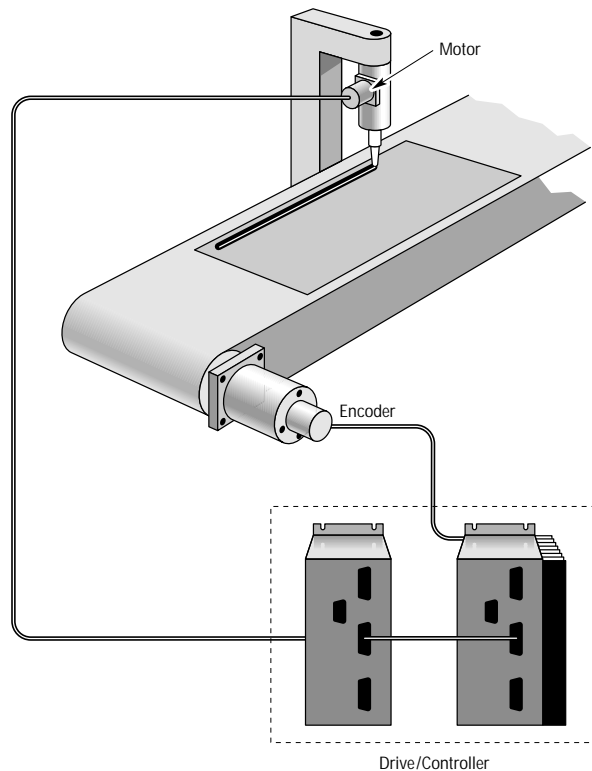

22. Moving Positioning System

Application Type: Following

Motion: Linear

Application Description: In a packaging application, a single conveyor of boxes rides between 2 conveyors of product. The product must be accurately placed in the boxes from alternate product conveyors without stopping the center conveyor of boxes. The line speed of the boxes may vary. When the product is ready, the controller must decide which box the product can be placed into and then move the product into alignment with the moving box. The product must be moving along side of the box in time for the product to be pushed into the box.

Machine Requirements:

- Reliable product packaging on the fly
- Standalone operation
- Multiple product infeeds
- Continuous operation without stopping the box conveyor

Motion Control Requirements:

- Programmable I/O
- Sequence storage
- Complex following capabilities
- Moving positioning system functionality
- Multitasking

Application Solution:

A standalone multiple-axis controller provides the control for this application. The controller can perform motion profiling based on an external encoder that is mounted on the center conveyor of boxes. The two product conveyors are driven by servo motors for high speeds and accelerations. The controller looks for a product ready signal from a sensor mounted on the product infeed conveyor and then makes a move based on the status of the boxes on the box conveyor and the status of the product on the other product conveyor. The controller is multitasking the control of the two product conveyors and the external encoder input, as well as a sensor input to monitor the status of the boxes. Thus the controller can instantaneously decide into which box the product should be placed and where that box is located. The controller then accelerates the product into alignment with the appropriate box in time for the product to be completely placed in the box, and continues to monitor the other rest of the product and box positions.

Product Solutions:

Controller	Drive	Motor	Encoder
Model 500	L Drive	L20	-E Encoder

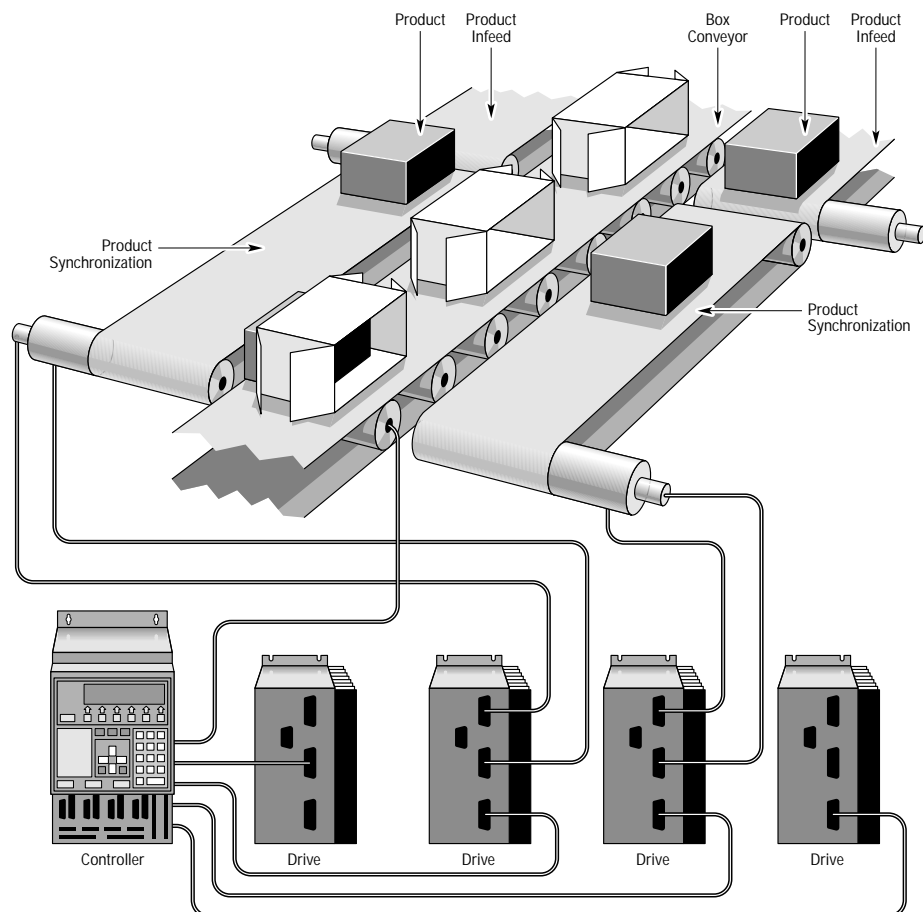

23. Plastic Injection Molding

Application Type: Injection Molding

Motion: Linear

Application Description: A manufacturer of injection molding machines wants a system that will close a molding chamber, apply pressure to the molding chamber for 5 seconds and then open the mold. This action needs to be synchronized with other machine events. When the molding chamber is open the motor must be 'parked' at a designated position to allow clearance to remove the molded part. The manufacturer would like an electronic solution (this is the only hydraulic axis on the current machine).

Machine Requirements:

- Electronic solution
- Computer-controlled solution
- 4000N (900lbs.) force

Motion Control Requirements:

- Position and torque control
- Serial link to computer and other drives
- Ability to change pressure and dwell

Application Solution: A BLHX75BP brushless servo drive with an ML3450B-25 motor and an ETS80-BO4LA Electro-Thrust Electric Cylinder were used. The motor drives the rod inside the cylinder and extends/retracts the top molding chamber. During this portion of the machine cycle, the servo drive must control the position of the motor. When the top molding chamber closes on the bottom molding chamber, a pressure must be applied. While pressure is being applied to the mold the position of the motor is not important. However, the motor must control the pressure on the molding chamber by applying a torque from the motor. A regular positioning servo can only apply torque by generating a position error—trying to control torque through position is not very accurate and can create instabilities. The BLHX servo was chosen because it can switch between position control and torque control on-the-fly without instability or saturation and then, while in torque control mode, directly controls motor torque.

Product Solutions:

Controller/Drive	Motor	Actuator
BLHX75BN	ML3450B-10	-ET580-BO4LA

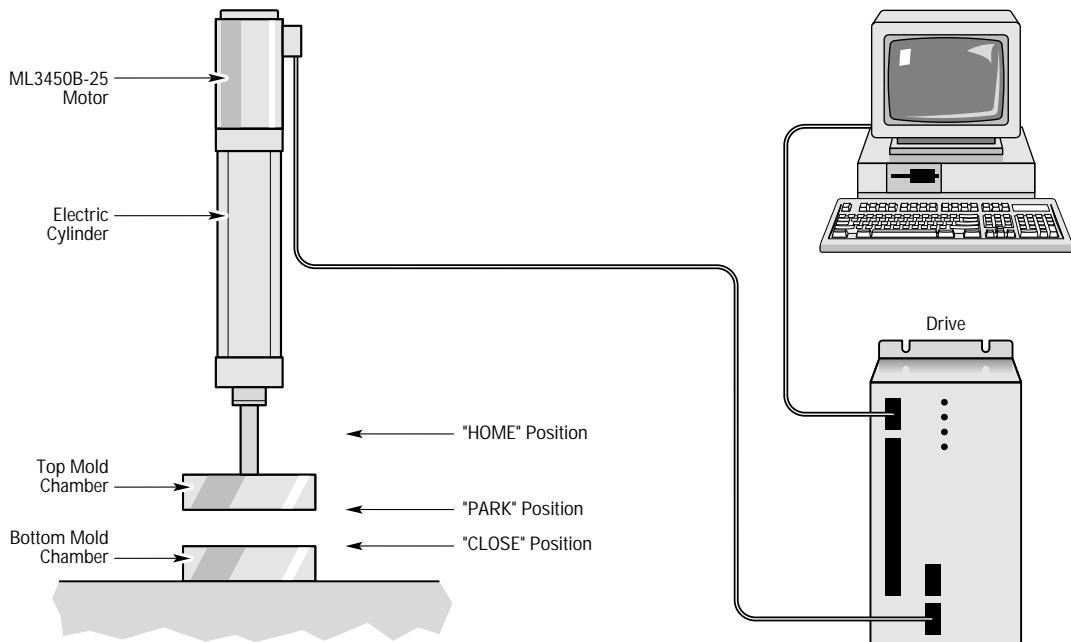

24. Rotating Tube Cutter

Application Type: Flying Cutoff

Motion: Linear

Application Description: Metal tubing feeds off of a spool and needs to be cut into predetermined lengths. A rotating blade mechanism is used to cut the tube, and the blade mechanism must spin around the tube many times in order to complete the cut. The throughput of this machine must be maximized, so the tubing cannot be stopped while this cut is being made. Therefore, to make a clean cut on the tube, the blade must move along with the tube while the cut is being performed.

Machine Requirements:

- Standalone operation
- Move cutting mechanism with the tubing to make the cut without stopping
- Simple user interface to set different tube lengths
- High accuracy on cut

Motion Control Requirements:

- Programmable I/O
- Program storage
- Position following
- High acceleration and speed

Application Solution:

A single-axis servo controller/drive was chosen to solve this application. An external encoder monitors the tube output and sends this information back to the servo system. The servo system tracks the length of the tube that is being fed past the cutting blade. Once the appropriate amount of material has been fed past the blade, the servo accelerates the cutting device up to the speed of the tube, sends an output to start the cutter, and then follows the tube speed exactly.

Product Solutions:

Drive/Controller	Motor
APEX6152	APEX610

