

## MVME2300

### VME Processor Modules

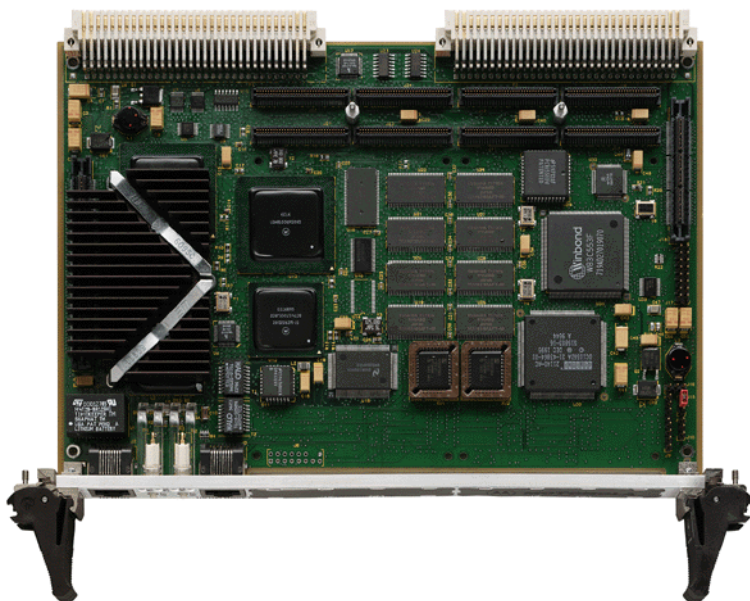

- ◆ PowerPC 603™ or PowerPC 604™ 32-bit microprocessor
- ◆ L1 cache—16KB/16KB PowerPC 603 or 32KB/32KB PowerPC 604
- ◆ 16MB to 128MB of on-board ECC DRAM
- ◆ Up to 1MB socketed Flash for on-board firmware or user-specified requirements
- ◆ 4MB on-board Flash memory for user-specified requirements
- ◆ On-board debug monitor with self-test diagnostics
- ◆ Two 32/64-bit PMC expansion slots with front-panel and P2 I/O
- ◆ 64-bit PCI expansion mezzanine connector
- ◆ 8K x 8 NVRAM and time-of-day clock with replaceable battery-backup
- ◆ One asynchronous serial debug port
- ◆ Four 32-bit timers, one 16-bit timer, one watchdog timer
- ◆ 10/100Mb/s Ethernet transceiver interface
- ◆ 4-level requester, 7-level interrupter, and 7-level interrupt handler for VMEbus

#### High-performance expansion VME board with the ability to customize applications

The MVME2300 series of VME boards provides the performance of Motorola's PowerPlus Architecture, and the ability to fully customize your application with two PCI Mezzanine Cards (PMCs).

Utilizing Motorola's PowerPC 603 or PowerPC 604 32-bit microprocessors, the Peripheral Component Interconnect (PCI) bus for the on-board peripherals, processor-memory bus to PCI bus bridge, and a VME interface, the MVME2300 processor modules pack optimum levels of flexibility and performance into a single VME slot.



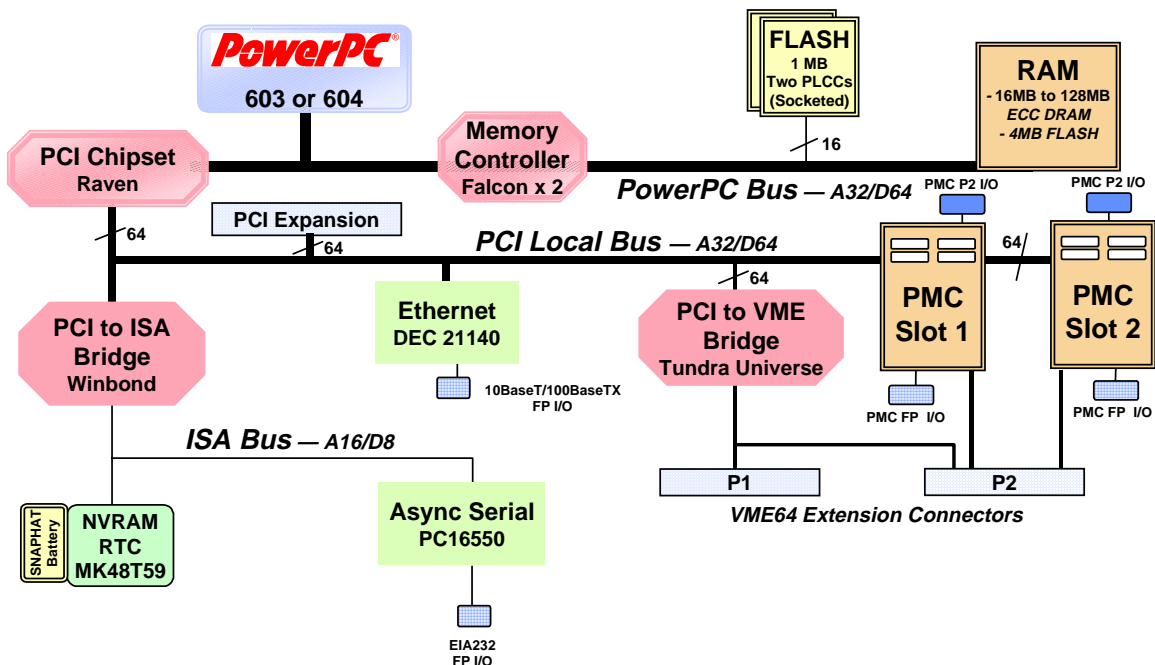

## MVME2300 Details

### IEEE P1386.1 Compliant PMC Slots

The MVME2300 features dual PMC ports with support for both front-panel and P2 I/O. P2 I/O-based PMCs which follow the PMC committee recommendation for PCI I/O when using the VME64 extension connector will be pin-out compatible with the MVME2300.

In addition to providing high-performance expansion I/O, the IEEE P1386.1 compliant PMC ports form a common architecture for future generations of products. Changing I/O requirements can be satisfied by simply replacing PMCs while reusing the same base platform, reducing the long-term cost of ownership.

### VME64 Extension Connector

To maximize the capabilities of the MVME2300, 5-row, 160-pin DIN connectors replace the 3-row, 96-pin connectors historically used on VME for P1 and P2. Two rows, Z and D, have been added to the VME P1/J1 and P2/J2 connectors providing a user with additional I/O. The VME64 extension connector is 100% backward compatible with existing VME card systems.

### PowerPlus Architecture

The PowerPlus Architecture is a processor and bus architecture fully optimized to get the maximum performance from the PowerPC microprocessor family, the PCI bus, and the VME-bus. The outstanding performance of VME processor boards based on the PowerPlus Architecture is not due to a single factor. A number of elements in the design of the PowerPlus Architecture contribute to its outstanding performance including the processor-memory subsystem, high-speed local bus, optimally decoupled architecture, decoupling the processor from PCI, and the advanced VME interface which reduces PCI delays. Contact your sales representative for details.

## Specifications

### Processor

Microprocessor:	MPC603	MPC604
Clock Frequency:	200 MHz	333 MHz
On-chip Cache (I/D):	16KB/16KB	32KB/32KB

### Memory

ECC Protected Main Memory:	Dynamic RAM with 66 MHz bus	
Capacity (60ns EDO):	16 or 32MB	
Capacity (50ns EDO):	64 or 128MB	
Single Cycle Accesses:	9 read/4 write	
Read Burst Mode (60ns):	9-1-2-1 idle; 3-1-2-1 aligned page hit	
Read Burst Mode (50ns):	8-1-1-1 idle; 2-1-1-1 aligned page hit	
Write Burst Mode:	4-1-1-1 idle; 3-1-1-1 aligned page hit	
Architecture:	128-bit, 2-way interleaved	
EEPROM/Flash:	On-board programmable	
Capacity:	1MB via two 32-pin PLCC/CLCC sockets; 4MB surface mount	
Read Access (4MB port):	68 clocks (32-byte burst)	
Read Access (1MB port):	260 clocks (32-byte burst)	
NVRAM:	8KB; 4KB available for users	
Cell Storage Life:	50 years at 55° C	
Cell Capacity Life:	10 years at 100% duty cycle	
Removable Battery:	Yes	

### VMEbus ANSI/VITA 1-1994 VME64 (IEEE STD 1014)

DTB Master:	A16–A32; D08–D64, BLT
DTB Slave:	A24–A32; D08–D64, BLT, UAT
Arbiter:	RR/PRI
Interrupt Handler/Generator:	IRQ 1–7/Any one of seven IRQs
System Controller:	Yes, jumperable or auto detect
Location Monitor:	Two, LMA32

### Ethernet Interface

Controller:	DEC 21140
PCI Local bus DMA:	Yes
Connector:	Routed to front panel via an RJ-45

### Asynchronous Serial Port

Controller:	PC16550
Connector:	Routed to the front panel via an RJ-45

### Counters/Timers

TOD Clock Device:	MK48T59; 8KB NVRAM
Real-Time Timers/Counters:	Four, 16-bit programmable
Watchdog Timer:	Time-out generates reset

### Miscellaneous

Reset and Abort switches and four LEDs for Fail, CPU, PMC1, PMC2 on front panel

### IEEE P1386.1 PCI Mezzanine Card Slot

Address/Data:	A32/D32/D64, PMC PN1, PN2, PN3, PN4 connectors
PCI Bus Clock:	33 MHz
Signaling:	5V
Power:	+3.3V, +5V, ±12V, 7.5 watts maximum per PMC slot
Module Types:	One double-wide or two single-wide front panel I/O or P2 I/O

Note: P2 I/O from PMC slot 2 is only accessible to systems equipped for VME64 extension connectors

### PCI Expansion Connector

Address/Data:	A32/D32/D64
PCI Bus Clock:	33 MHz
Signaling:	5V
Connector:	114-pin connector located on the planar of the MVME2300

### Power Requirements

	<b>+ 5V ± 5%</b>
MVME2300 w/ MPC603 @ 200 MHz:	4.0 A typical, 4.75 A max.
MVME2300 w/ MPC604 @ 333 MHz:	5.0 A typical, 5.5 A max.

Note: Power requirements are PMC dependent at +12 and –12 volts.

### Board Size

Height:	233.4 mm (9.2 in.)
Depth:	160.0 mm (6.3 in.)
Front Panel Height:	261.8 mm (10.3 in.)
Width:	19.8 mm (0.8 in.)
Max. Component Height:	14.8 mm (0.58 in.)

### Demonstrated MTBF

(based on a sample of eight boards in accelerated stress environment)

Mean:	190,509 hours
95% Confidence:	107,681 hours

### Environmental

	Operating	Nonoperating
Temperature:	0° C to + 55° C, forced air cooling	–40° C to + 85° C,
Altitude:	5,000 m	15,000 m
Humidity (NC):	10% to 80%	10% to 90%
Vibration:	2 Gs RMS, 20–2000 Hz random	6 Gs RMS, 20–2000 Hz random

### Electromagnetic Compatibility (EMC)

Intended for use in systems meeting the following regulations:

U.S.: FCC Part 15, Subpart B, Class A (non-residential)

Canada: ICES-003, Class A (non-residential)

This product was tested in a representative system to the following standards:

CE Mark per European EMC Directive 89/336/EEC with Amendments; Emissions: EN55022 Class B; Immunity: EN50082-1

## Safety

All printed wiring boards (PWBs) are manufactured with a flammability rating of 94V-0 by UL recognized manufacturers.

## Software Support

The MVME2300 is supported by a variety of operating systems, including a complete range of real-time operating systems and kernels.

### Ordering Information

Part Number	Description
All models contain 5MB Flash.	
<b>MVME2301</b>	200 MHz MPC603, 16MB ECC DRAM
<b>MVME2302</b>	200 MHz MPC603, 32MB ECC DRAM
<b>MVME2303</b>	200 MHz MPC603, 64MB ECC DRAM (not available with connector for PCI expansion)
<b>MVME2304</b>	200 MHz MPC603, 128MB ECC DRAM
<b>MVME2304-0111</b>	333 MHz MPC604, 16MB ECC DRAM, original VME Scanbe front panel and handles
<b>MVME2304-0113</b>	333 MHz MPC604, 16MB ECC DRAM, IEEE 1101 compatible front panel with injector/ejector handles
<b>MVME2304-0121</b>	333 MHz MPC604, 32MB ECC DRAM, original VME Scanbe front panel and handles
<b>MVME2304-0121SC</b>	333 MHz MPC604, 32MB ECC DRAM, original VME Scanbe front panel and handles w/ serial I/O pin-out
<b>MVME2304-0123</b>	333 MHz MPC604, 32MB ECC DRAM, IEEE 1101 compatible front panel with injector/ejector handles
<b>MVME2304-0131</b>	333 MHz MPC604, 64MB ECC DRAM, original VME Scanbe front panel and handles
<b>MVME2304-0131SC</b>	333 MHz MPC604, 64MB ECC DRAM, original VME Scanbe front panel and handles w/ serial I/O pin-out
<b>MVME2304-0133</b>	333 MHz MPC604, 64MB ECC DRAM, IEEE 1101 compatible front panel with injector/ejector handles
<b>MVME2304-0141</b>	333 MHz MPC604, 128MB ECC DRAM, original VME Scanbe front panel and handles
<b>MVME2304-0141SC</b>	333 MHz MPC604, 128MB ECC DRAM, original VME Scanbe front panel and handles w/ serial I/O pin-out
<b>MVME2304-0143</b>	333 MHz MPC604, 128MB ECC DRAM, IEEE 1101 compatible front panel with injector/ejector handles

## Related Products

<b>PMCSAN-002</b>	Primary PCI expansion, mates directly to the MVME2300 providing slots for either two single-wide or one double-wide IEEE P1386.1 compliant PMC cards; optional PMCSAN-010
<b>PMCSAN(1)-002</b>	PMCSAN-002 with original VME Scanbe ejector handles
<b>PMCSAN-010</b>	Secondary PCI expansion, plugs directly into PMCSAN-002 providing two additional PMC slots
<b>PMCSAN(1)-010</b>	PMCSAN-010 with original VME Scanbe ejector handles
<b>MPMCxxx</b>	Motorola's family of PMC modules; ask your sales representative for details

## Documentation

<b>V2300A/IH</b>	MVME2300 Installation and Use Manual
<b>V2300A/PG</b>	MVME2300 Programmer's Reference Guide
<b>PMCSANA/IH</b>	PMCSAN Installation Guide
<b>PPCBUGA1/UM</b>	PPC1Bug User's Manual, Part 1 of 2
<b>PPCBUGA2/UM</b>	PPC1Bug User's Manual, Part 2 of 2
<b>PPCDIAA/UM</b>	Firmware Diagnostics Manual

Documentation is available for on-line viewing and ordering at <http://www.motorola.com/computer/literature>.

[www.motorola.com/computer](http://www.motorola.com/computer) 1-800-759-1107



**MOTOROLA**

**Motorola Computer Group Worldwide Headquarters:** 2900 S. Diablo Way, Tempe, AZ 85282

**Sales Offices:** *United Kingdom:* +44 (0) 1256 790555 • *Asia Pacific and Japan:* 852-2966-3209 • *France:* +33 (0) 1 64 86 64 00 • *Germany:* +49 (0) 611-3611 604 • *East Mediterranean:* 972-3-610-4388 • *Canada & Central Pan America:* 888-366-3624 • *Eastern Pan America:* 703-714-0725 • *Western Pan America:* 408-991-8633

Motorola and the stylized M logo are registered trademarks and DigitalDNA and the Digital DNA Logo are trademarks of Motorola, Inc. PowerPC and the PowerPC logo are registered trademarks; and PowerPC 603 and PowerPC 604 are trademarks of International Business Machines Corporation and are used by Motorola, Inc. under license from International Business Machines Corporation. All other product or service names are the property of their respective owners.

This data sheet identifies products, their specifications, and their characteristics, which may be suitable for certain applications. It does not constitute an offer to sell or a commitment of present or future availability, and should not be relied upon to state the terms and conditions, including warranties and disclaimers thereof, on which Motorola may sell products. A prospective buyer should exercise its own independent judgement to confirm the suitability of the products for particular applications. Motorola reserves the right to make changes, without notice, to any products or information herein which will, in its sole discretion, improve reliability, function, or design. Motorola does not assume any liability arising out of the application or use of any product or circuit described herein; neither does it convey any license under its patent or other intellectual property rights or under others. This disclaimer extends to any prospective buyer, and it includes Motorola's licensee, licensee's transferees, and licensee's customers and users. Availability of some of the products and services described herein may be restricted in some locations.

© Reg. U.S. Pat. & Tm. Off.

© 1997 Motorola, Inc. All rights reserved. M2300-D5 12/00