



WORKSHOP 2009

JULIE
hp

English



THE PASSION PEOPLE



Ground contact isn't that important to you. There is (almost), no terrain where a **Freerider** won't go. Tough and stable components are a must have. Here they are.

There are bikers out there for whom uphill is just a means to an end. The downhill fun is having absolute priority for them. With lots of travel and robust components the **Enduros** must cope with technically hairy downhills and bike-park weekends..

You're an all-rounder. You love long and sweeping trails, up as well as down. The optimum mix of light weight and stability is the hall mark of your **All Mountain** components meant for a broad spectrum of use.

Mile after mile over the dusty trails as well as hard fast tar-mac. On every ride your bike should be the epitome of uncomplicated - and naturally the parts for your **X-country** adventures shouldn't cost the earth.

Race-orientated means for us the minimum weight that is technically possible. Every gram extra weight can be the decisive factor between winning or losing for you, the **racer maniac**.

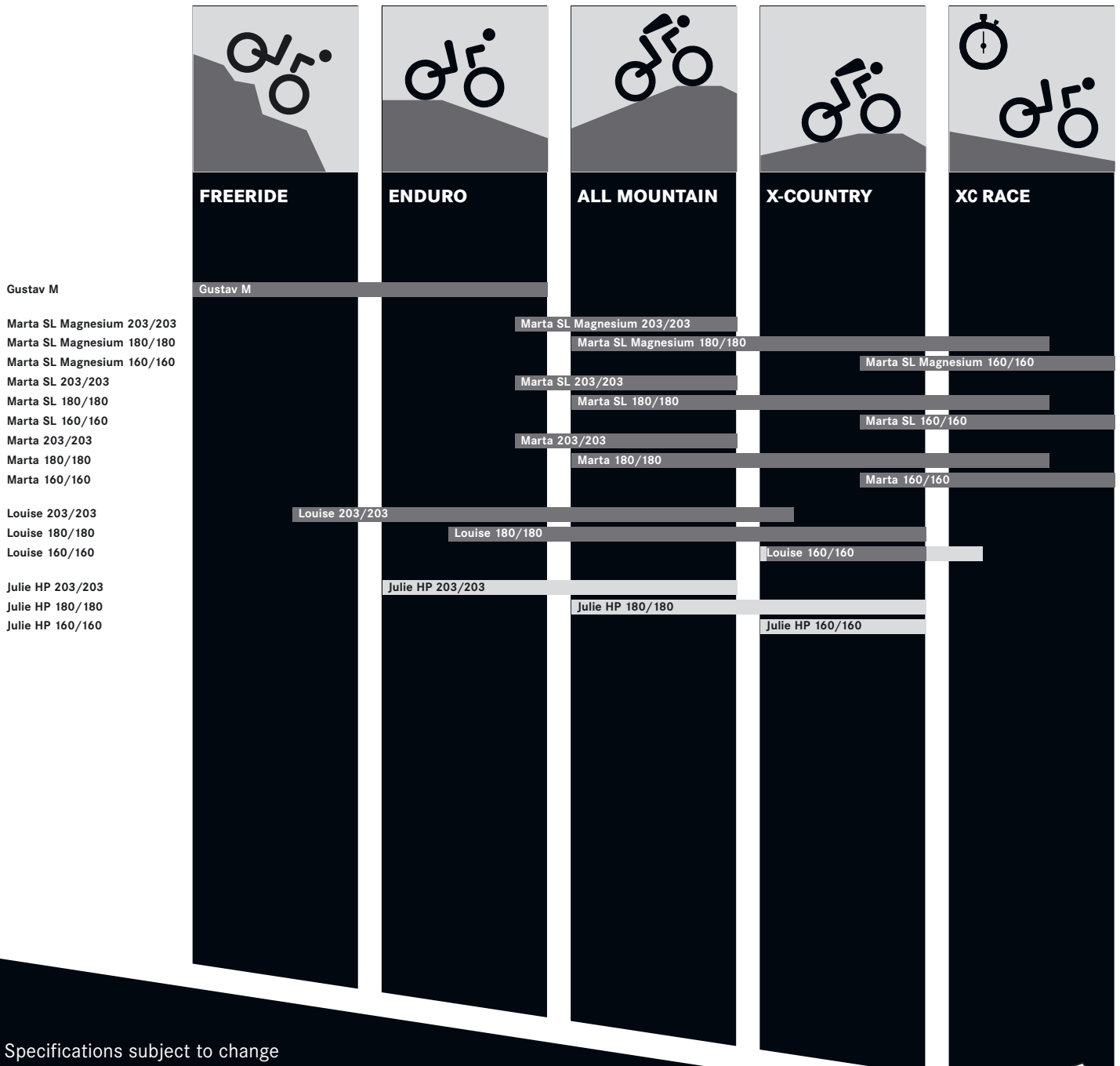

Specifications subject to change without prior notice



Table of Contents

1. Introduction	4
2. Safety instructions before the first ride	5
3. Safety instructions before every ride	5-6
4. Transport of the bicycle	6
5. Brake installation	7-10
6. Shortening the hose	10-11
7. Maintenance	12-13
8. Repairs	14
9. Bleeding and Filling	15-16
10. The disc brake wheel	17
11. Accessories	18
12. Warranty	18
13. Trouble Shooting	19
14. Spare parts, tuning adaptors	20-21



WARNING:

This symbol means possible danger for your health and even life if you do not follow the instructions given respectively if the necessary safety measures are not followed.



ATTENTION:

This symbol warns you of inappropriate handling that might cause serious damage to the material and/ or the environment.



NOTE:

This symbol gives you additional information about the general handling of the product or gives hints to paragraphs in this manual which have to be read carefully.

1. Welcome to the Passion People!



Brake lever (master cylinder)
MAGURA Julie HP

Congratulations! You have purchased a fully hydraulic MAGURA disc brake proudly „Made in Germany“. You will be amazed at the awesome braking power and the minimum amount of maintenance that is necessary on our stoppers. Good to know that you are not alone, millions of riders worldwide rely on them and every day our numbers are increasing.



Brake calliper and rotor
MAGURA Julie HP

On the fully hydraulic MAGURA disc brake system Julie HP the braking force is transmitted to the braking surface by a mineral oil column. The movement of the lever blade moves a piston, which is integrated in the brake lever (master cylinder). The piston pushes the mineral oil column through the brake hose in the direction of the brake calliper, where two pistons, on which the brake pads are fixed, are pushed out. The friction between the brake pads and the rotor slows down the bicycle and causes both the rotor and the brake calliper to heat up.

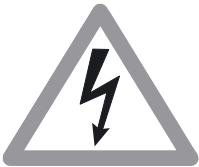

Never touch either the rotor or the brake calliper after long braking as this may cause serious burns.

You will be pleased to find out that the MAGURA Julie HP disc brakes offer a superior braking power even with little hand force applied, no matter what the weather conditions should be. Particularly in wet weather conditions disc brakes are much more responsive than rim brakes and transmit their enormous power immediately after activating the brake lever.

Disc brakes don't wear your rims down. However, if they have been mounted incorrectly, they might cause a squealing noise during braking, mainly during wet weather conditions.



This manual contains important information about the safe installation, operation and maintenance of your MAGURA disc brake. We urge you to read it carefully, become familiar with its contents and follow our recommendations to help make your new braking experience enjoyable and trouble free. Please note that the Louise brake is delivered in different versions with different rotor diameters and for different fitting alternatives for which we offer a variety of adaptors. The basic installations steps remain however always the same.

Although the Julie HP disc brake system is relatively simple you should not overestimate your technical skills! We therefore advise you to leave the following operations to a trained technician of a professional bike shop.

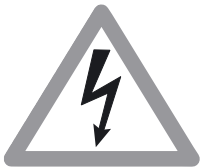

This manual is part of the product. Do not hand over the product to third parties without this manual. Technical specs are subject to change without prior notice.

Should there be any further questions or problems we warmly recommend you to visit our website www.magura.com where you will always find the newest and hottest tips about all our products. On magura.com you can also download this manual in a convenient A4 format, in the forum you get free support around the clock. Stay tuned with the Passion People!

Thank you for your confidence in our products, enjoy your ride and your new MAGURA disc stoppers!

Happy trails!

2. Before the first ride

1. Are you already familiar with hydraulic disc brakes? Our brakes might be much more powerful than the stoppers on which you relied on so far. Take your bicycle to a safe area to learn the proper braking technique and operation of your new brakes and your bike.

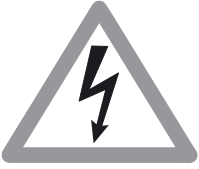

2. Check that the front brake is still actuated by the lever on the side you are used to braking with. Should this not be the case you will have to train to your new setup, otherwise any unintended front wheel braking manoeuvre may cause an accident leading to possible serious injury! If in doubt get a trained technician to swap the hoses. For further hints concerning swapping of the brake hose see page 10 onwards.

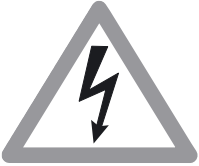

3. New brakes and new rotors or brake pads must always be run in by braking at least 30 times from a speed of 30 km/h to achieve the maximum brake power. Take your bike to a safe place to run in the brake.

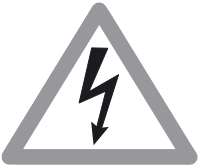

4. While riding in extreme riding conditions (total weight of bike plus rider over 100 kg and/ or a gradient of more than 15 %) always use both brakes simultaneously to slow your bike down.

5. Use your Julie HP disc brake according to the user chart on page 2 of this manual. Any misuse might cause serious accidents with fatal injuries to yourself and others!

6. Are you familiar with the other components on your bike such as gears, clipless pedals and suspension units? Always practise using your bike in a safe area to improve your handling abilities before using it on the road. Consult the user's manual of your bike to learn more about this.

7. For your own safety always wear a helmet when you ride a bicycle. Make sure as well that you wear suitable clothing and footwear.

3. Before every ride

Always check carefully the following points:

1. Always make sure that the quick release skewers of your wheels and seat post are correctly mounted and closed.

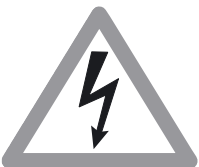

incorrectly installed quick release skewers might cause the fixed items to become loose. Serious accidents with severe injury may result!!

2. Always make sure that the brake lever pressure is o.k. by pulling the lever blade and ensuring that full braking performance is achieved before the lever blade touches the handlebars. If this is not the case, pull the lever blade several times (pump) until the brake pads touch the rotor.

Changing pressure points during a ride might be the result of having air in the brake system.

See hints about filling and bleeding from on pages 15/16.

3. Always make sure that the brake system does not have any leaks by activating the lever blade, holding it and checking the hose connections and reservoir cover for eventual leaks. (Also see page 11)

4. Always protect your rotors and brake pads from oil and lubricants (e.g. by lubricating your chain). Avoid detergents and soap on the brake pads. Contaminating the pads with oil and lubricants will cause a permanent loss of braking power. Such contaminated pads can no longer be used and should be replaced! Clean a contaminated rotor with MAGURA disc cleaner, dishwasher or alcohol. See further hints about changing the brake pads on pages 12-13.

5. Release your brake lever and check whether your wheel moves freely and without drag. Check eventually whether the wheels are correctly mounted and if the quick release skewers are tightened sufficiently. (Also see page 9)

6. Are your tires in a good condition, and have they enough air pressure? Test this with your fingers. Lift up your bike and turn the wheels of your bike. An insufficient rotation might be due to damaged tires, broken axles and/or broken spokes.

7. Pick up your bike and let it drop from a moderate height. Listen for any rattling noises. If any are heard check the bearings and all screwed connections.

8. Always follow the instructions given in the owner's manual of your bicycle.

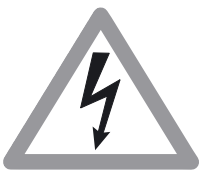

Never use your bicycle if any of the points mentioned above relate to your bicycle! Consult a professional bike mechanic if you feel unsure. A faulty bicycle may result in serious accidents with possible fatal injuries of the rider! Be careful to check always to check the following points:

4. Transport of the bicycle



In case of a disc brake equipped bicycle you should always keep in mind the following points:

Never activate the lever blade without the brake pads in place and the wheels mounted. In case this should have happened see page 10 of this manual.

Never throw away the transport device, which has been delivered with the brake. Always clip it between the brake pads whenever the wheel is removed (e.g. transport of the bike).



Always carefully remove wheels. Make sure that the rotors are not damaged, deformed or contaminated with lubricants.

If the bike is transported upside-down squeeze (with mounted wheel or transport device!) the lever blade before, hold pressure and fix the blade in this position with a rubber band or a cable tie.

During transport in an aircraft you can leave your brake as it is, e.g. you do not have to empty it.

5. Brake Installation

1. Tools for installation (+maintenance)

Allen key 2*, (3) and 5
transport/mounting device*
sharp knife
8 mm open end wrench
flat blade screw driver
Torx T25 key*
(Torx T7 key)

(*delivered with the brake)

Always insert the allen and torx keys completely to avoid damaging the bolt heads.

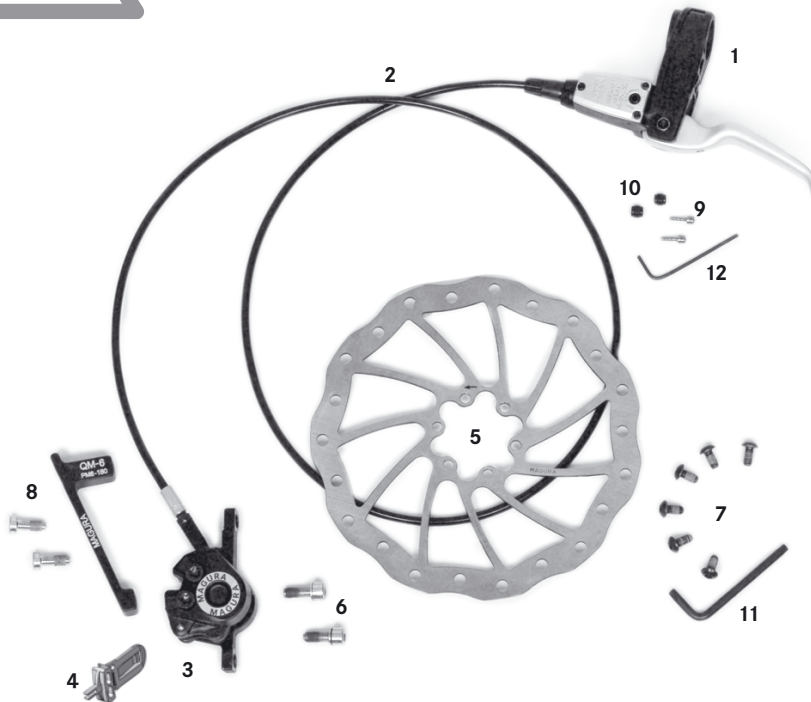

Unpack your Julie HP disc brake:

1. brake lever (master cylinder) connected through the
2. brake hose with the
3. brake caliper with transport device; **ATTENTION:**
4. remove the transport device only shortly before installation of the wheel!
5. rotor
6. fitting bolts for rotor Torx T25 (6 pieces)
7. fitting bolts for caliper Allen key 5 (2 pieces)
8. adaptor with fitting bolts (depending on model)
9. hose inserts (2 pieces)
10. olives (2 pieces)
11. Torx T25 key
12. 2mm Allen key

specifications modifying and improving this product are subject to change without prior notice.



The brake levers and callipers of the different MAGURA disc brake models are completely different and not compatible! Never mix and match parts from the models. Any misuse might cause serious accidents!



MAGURA manufacture these braking systems according to the valid standards and make many rigorous product tests. Because of the large variety of forks and frames available on the market it is impossible for MAGURA to test all possible combinations. If you mount any of our brake systems always make sure that the brakes are in conformity with the bicycle.



Disc brake callipers can generate a lot of heat during extreme riding conditions. The resulting heat transfer from the calliper to the fork and/ or frame can have a negative influence on the mechanical characteristics of both the fork and/ or the frame.

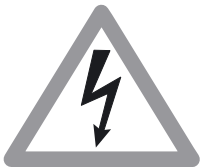

Insufficient heat transfer from the brake calliper to the frame and the fork, caused by fork and or frame components having low heat transfer characteristics (e.g. carbon rear triangles) can cause the brake to overheat, with the possibility of a total failure of the brake system. This can cause serious personal injury to yourself and/ or others.

With respect to product liability we remind all our users that any manufacturer (also: bike mechanic or end consumer!) is responsible for the correct function of the complete bicycle in this context. Improper combinations and insufficient installation can cause damage and serious accidents!



2. Mount the brake lever to the handlebar with a 5 mm allen key. If you install your brake lever the first time you'll hear a crack, do not worry because of that. Tightening torque 4 Nm/ 34 in.lbs



The MAGURA disc brake Julie HP is compatible with frames and forks which meet the International Standard (IS) and for Postmount (PM) mounts. Depending on the mounting standard and/or rotor size adaptors are used for a proper installation (cf. table on page 21). Never mount the brakes with adaptors or brackets from other manufacturers! All warranty will be void in case of any misuse! Use only direct mounting parts from MAGURA or the frame or fork's manufacturer!



Make sure that the calliper fitting eyelets on your frame or fork are free of any paint, powder coating or burrs. (arrows). If this is not the case you should contact your dealer who will be able to clean the surfaces, providing an absolutely flat/even mounting surface (also see page 9).

ATTENTION: The treatment of suspension lower legs made of magnesium might be dangerous because of corrosion! Always follow the safety instructions given by the respective manufacturer! Always make sure after having treated the disc brake mounts that these are protected against corrosion by using an appropriate protective paint.

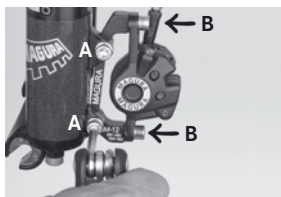

3. Mounting on forks and frames that meet the International Standard: Mount the calliper onto the fork or the frame (bolts "A"). Use a 5 mm allen key. **Tightening torque: 6 Nm/ 51 in.lbs. Do not tighten yet the bolts "B"**



4. Mount the rotor with the 6 Torx T25 bolts onto the hub. Watch out for the correct rotation direction of the rotor (laser arrow). Use only new original bolts or thread lock if you use old bolts. **Tighten the bolts in a crossed pattern! Tightening torque: 4 Nm/ 34 in.lbs.**



5. Remove the transport device shortly before installing the wheel and mount the wheel. Install the wheel by positioning the rotor between the brake pads and fixing the wheel in the dropouts. Close the quick release of your wheel **which you should mount on the opposite side of the brake calliper** and tighten it sufficiently. As to thru-axle hubs or wheels consult the manual of the respective fork manufacturer.



6. Squeeze now the brake lever, hold the pressure.



7. Tighten the fitting bolts "B". **Tightening torque: 6 Nm/ 51 in.lbs.**



8. Mounting on forks with Postmount: For Postmount 6" installation in combination with a 160mm rotor, Postmount 7" with 180mm rotor or Postmount 8" with a 203mm rotor on the front you do not need an adaptor. Mount the calliper **DIRECTLY** onto the fork with **MOUNTED** wheel and rotor. For a better understanding the mounted wheel is not shown on this picture. Do not tighten the calliper bolts yet! Squeeze the lever blade and keep the pressure. Tighten now the bolts. **Tightening torque: 6 Nm/ 51 in.lbs. Further mounting alternatives cf. page 21 of this manual.**



The transport device prevents the brake pads from being pushed out too far by unintended lever squeeze. It is impossible then to install the wheel with the rotor. So never throw away the transport device. Keep it and always clip it between the brake pads when the wheel is removed.



9. Hose routing with the Heat Eater fitting.

The Heat Eater fitting of the Louise caliper allows a 45° rotation for the optimum hose routing without using tools. Fix the hose on the fork and/or frame after you have found the ideal position, **the Heat Eater must NOT move during compression of the fork and/or frame!**



Do not worry when you hear friction between rotor and pads. A slight drag is normal on disc brakes with automatic pad wear adjustment during the break-in period. This drag will disappear after a while. The reason for this is that the brake pads find their optimum working position towards the rotor, only after a slight wear during the break-in period. Slight drag might also happen after a brake pad change or in case of an incorrectly installed wheel.



In case of a **constantly dragging** disc brake causing noise your frame is badly aligned. In such a case you should contact your dealer who can care with the MAGURA Gnann-o-mat disc optimizer for a totally even surface of the disc brake mounts. These are absolutely necessary for a drag free function of your brake.

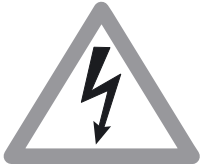

New brakes and/or new rotors or brake pads must always be run in by breaking at least 30 times from a speed of 30 km/h to achieve the maximum brake power. Take your bike to a safe place to run in the brake.



10. Reach adjust is done with a 2 mm Allen key. Turning key clockwise: lever blade moves away from the handlebar, turning counterclockwise: blade moves to the handlebar.

6. Shorten the hose



Julie HP is a high-pressure system and comes with a reinforced hose, the „MAGURA Disc Tube“ wearing also this imprint. The Disc Tube needs an additional insert for a proper fitting. Never mix and match the parts from the MAGURA Louise with the ones of our rim brakes or other manufacturers' brakes! Any misuse might cause serious accidents!

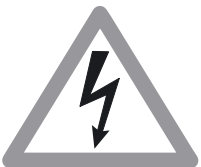

Never touch either the rotor or the brake calliper after long braking as this may cause serious burns.



1. Remove the wheel so that you have free access to the brake caliper. Push back both brake pads by putting the transport device or a flat blade screwdriver into the gap. Move the screwdriver **slowly** back and forth until both calliper pistons are fully retracted and flush with calliper body.

Never push back the pistons without the brake pads mounted! Open the brake system only after having fully pushed back the brake pads.



2. Loosen the brake lever clamping screw with a 5 mm allen key. Turn the brake lever and ensure that the reservoir is horizontal.



3. Slide the hose protection. Unscrew the sleeve nut on the brake lever with an 8 mm open-end wrench and pull the hose out **carefully**. **Hold the hose carefully to avoid any loss of oil! Do not squeeze the lever blade with the system open!**



4. Put the hose on a workbench and shorten it with a sharp knife. The best tool is the MAGURA cutter. **Do not use saws or pliers!**

If your frame is not equipped for routing hydraulic lines you should now mount the hose fitting kit (available as separate accessory, see magura.com) for your rear brake according to the instructions that are included in the kit. **Hold the hose carefully so that it cannot snap away! Cut the hose squarely! The sleeve nut can be reused. The olive cannot be reused and must be replaced!**

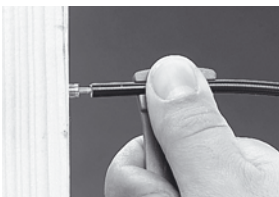

5. Press by hand a **new** insert into the hose until it is **fully seated**. Clamp the hose into the groove of the mounting device as shown...



6. ...or clamp the mounting device as shown into a vice and hammer the insert **carefully** into the hose. If your frame is not equipped for routing hydraulic lines you should now mount the hose fitting kit for your rear brake according to the instructions that are included in the kit.



7. Slide on the sleeve nut and a **new** olive onto the hose. Push the hose with the sleeve nut and the new olive **fully** into the brake lever and tighten the sleeve nut with an 8 mm open-end wrench. **Tightening torque: 4 Nm/34 in.lbs.**

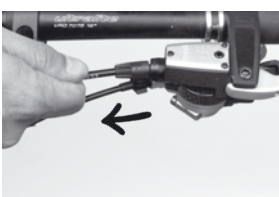

8. Always check for correct installation by pulling on the hose. Make sure that the system has no leaks. Squeeze the lever blade, hold pressure and check hose connections and the reservoir cover for eventual leaks.

Squeeze the lever blade several times (pump) to push the pads to their proper position until the lever feel becomes very firm. If you cannot realize this, bleed the brake (see page 15 onwards).

7. Maintenance

Brake Oil: MAGURA disc brakes use a transmission medium low viscosity mineral oil, the biodegradable MAGURA ROYAL BLOOD. Contrary to DOT brake fluid the MAGURA ROYAL BLOOD does not irritate human skin or strip the paint of your frame. Moreover it does not absorb water like DOT and does not have to be changed regularly. What sounds unbelievable is a fact: you can use your brakes over years without having to touch them (except brake pad change!)

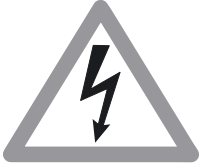

Always make sure that the brake system does not have any leaks by activating the lever blade, holding it and checking the hose connections and reservoir cover for eventual leaks. Consult a trained technician in case of leaks. Leaks cause poor braking performance with possible serious accidents!

As to hints about repairs of the hose see page 14 onwards..

Brake pads: wear, control and replacement

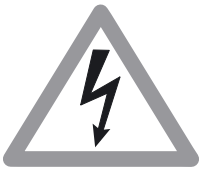

Brake pad wear: The brake pads are subject to wear due to friction between rotor and pads. The Julie disc brake features a fully automatic pad wear adjustment. Regularly check the thickness of your brake pads and replace them, if necessary!

Control and replacement of the brake pads



1. Squeeze the lever blade with the wheel mounted and hold the pressure.



2. Check out whether the “finger” of the transport device fits in-between the “ears” of the the brake pads. **On the picture on the left this is NOT the case, the pads must be changed.**

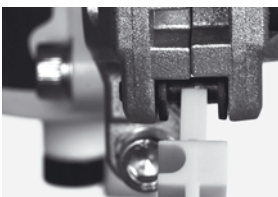

3. Here the finger of the transport device fits between the “ears” of the brake pads. **The pads are still o.k.. Remember: the lever has to be pulled during this procedure. Use for this a rubber band or a cable tie.**

Replacement of the brake pads

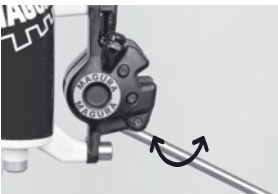

4. Remove the wheel so that you have free access to the brake calliper. Push both brake pads back by putting the transport device or a flat blade screwdriver into the gap. Move the screwdriver **slowly** back and forth until both calliper pistons are fully retracted and flush with calliper body.



Never push back the pistons without the brake pads mounted!



5. Remove the cotter the brake pad fitting screw with a 2mm Allen key.



6. Pull out the brake pads. Their „ears“ make this very easy. Clean the pads with a dry rag that is free of oil and grease.



Never squeeze the lever blade without the brake pads in place and the wheel mounted. If this happened by accident push back the pistons with mounted brake pads by using the transport device or a flat blade screwdriver.

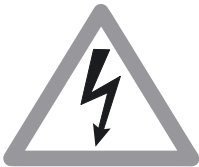

Use only genuine MAGURA brake pads. MAGURA cannot guarantee a correct function of the brake if you use brake pads from other manufacturers, which were not tested. Using other pads might cause poor braking and cause serious injury! All warranty claims will be void in case of misuse!

7. Clean on the occasion of the brake pad change, the brake body with a clean rag. Make sure that the friction side of the new brake pads points towards the rotor.



8. Secure the new pads with the fitting screw, a new one is delivered with the new pads. **Tightening torque: 1 Nm/ 9 in.lbs. Check the correct fitting of the pads by pulling them. The fitting bolt of the pads has to be correctly installed e.g. it has to go through the drills of the pad holders and then correctly screwed into the caliper.**

9. Re-install the wheel and check for a correctly tightened quick release skewer of the wheel.



10. Squeeze the lever blade several times (pump) to push the pads to their proper position until the lever feel becomes very firm.

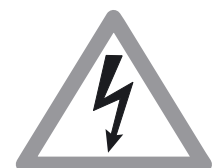

New brakes and/ or new rotors or brake pads must always be run in by braking at least 30 times from a speed of 30 km/h to achieve the maximum brake power. Take your bike to a safe place to run in the brake.

Never contaminate brake pads with oil or grease this causing permanent loss of brake power! Such contaminated pads can no longer be used and should be replaced!

8. Repairs



Disc brake service kit

Don't panic if the hose snaps! With the disc brake service kit and a separately available spare hose (see spare parts pages 20/21), this can be repaired easily.

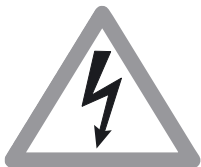

Julie HP is a high-pressure systems and comes with a reinforced hose, the „MAGURA Disc Tube“ wearing also this imprint. The Disc Tube needs an additional insert for a proper fitting. Never mix and match either the hoses or parts from other manufacturers. Any misuse might cause serious accidents!

1. Remove the damaged hose from both the brake lever and the caliper.



2. Prepare a new hose: Use only the reinforced MAGURA Disc Tube (wearing also this imprint). One end of this hose comes **with a pressed fitting with blue loctite threadlock**, which has to be screwed into the Heat Eater as described above.

The hose is available with 0° and 90° fittings (c.f. page 20)

Tightening torque: 6 Nm/ 51 in.lbs.



Use with all Julie HP models with adjustable Heat Eater hose fitting only the hose that comes with the fitting with blue loctite threadlock (arrow!).

NEVER shorten the MAGURA Disc Tube hose at the end with the pressed fitting! You could no longer use this hose then.



3. Tighten the prepared end of the new hose onto the Heat Eater.

Tightening torque: 6 Nm/ 51 in.lbs.

4. Install the hose as described in chapter 6.



After the installation of a new hose you will always have to refill the brake. The following chapter 9 describes how the filling and bleeding has to be done.

9. Filling and bleeding a brake



Brake Oil: MAGURA disc brakes use as transmission medium low viscosity mineral oil, the biodegradable MAGURA ROYAL BLOOD. Contrary to DOT brake fluid the MAGURA ROYAL BLOOD does not irritate human skin or strip the paint of your frame. Moreover it does not absorb water like DOT and does not have to be changed regularly. What sounds unbelievable is a fact: you can use your brakes over years without having to touch them (except brake pad change!)



1. Loosen slightly the clamping screw of the brake lever with a 5 mm allen key and **turn the brake lever so that the reservoir is positioned horizontal**. Slightly tighten the clamp screw in that position.



2. For filling and bleeding a MAGURA disc brake you will need the disc brake service kit including all necessary tools.



3. Prepare the transparent filler tube by pushing in by hand the M6 barbed fitting. Put the other end of the filler tube on the syringe and fill the syringe **completely** with MAGURA ROYAL BLOOD mineral oil. Fill the syringe completely and make sure that **there are no air bubbles inside**. Turn the syringe eventually to push out air bubbles.



4. Remove the brake pads as described on page 14 and slide the transport device as shown **with its THICK END** between the caliper pistons. Squeeze slightly the lever blade (pump) to tighten the transport device. It is advisable to fix the device with a rubber band on the caliper.



5. Fix the Heat Eater fitting of the caliper so that it points UPWARDS!. Unscrew now the bleed screw with a 5 mm allen key. Screw in the prepared syringe and tighten it with a 8 mm open end spanner.



Place now a rag, which has to be free of oil or lubricants around the reservoir and, more important, around the brake caliper. Care for a clean working environment! No dirt or particles may come into the brake system!

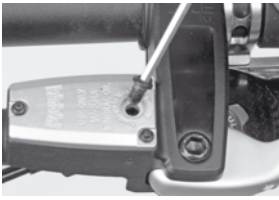

6. Remove **ONLY** the bleed plug of the reservoir with a 2,5mm Allen key that you insert into the plug before turning it slightly. The reservoir cover and the membrane underneath remain on the brake lever!



7. Put the second syringe of the service kit **WITHOUT PLUNGER** into the opened drill of the reservoir cover. Push oil from the brake caliper upwards until the oil column arrives in the syringe on the reservoir. You will see air bubbles now.



8. Now suck the oil carefully back with the filling syringe on the brake caliper. Make sure that there is always enough oil in the reservoir syringe when you suck back the oil with the filling syringe! You will see air bubbles again.



9. Actuate in addition **CAREFULLY** the lever blade to chase tiny air bubbles that might hide within the system. The job is done when no air bubbles can be seen after having followed the steps above several times.



10. **Before you remove the syringe on the reservoir make sure that there is only a small quantity of oil inside.** Place a rag around the brake lever and the caliper thus preventing overflowing oil from dropping down and contaminating and killing the brake pads. Remove the syringe and close the end that was inserted into the reservoir quickly with your finger. Empty the remaining content of the syringe into a container.



11. Close the plug on the reservoir cover as shown by pressing it by hand into the drill. That's it!



12. Remove the filling syringe and screw in the 5mm allen bleed screw. **Tightening torque: 2,5 Nm/ 22 in.lbs.** Re-install the brake pads and the wheel.



Always pull the lever blade several times (pump) until the brake pads touch the rotor. Always check for correct installation by activating the lever blade and checking for eventual leaks. Never contaminate brake pads with oil or grease this causing permanent loss of brake power! Contaminated pads are definitely killed and **MUST be replaced! A contaminated rotor can be cleaned with MAGURA brake cleaner, warm dishwater or alcohol.**

10. The disc brake wheel



10. Replace the cover with the membrane onto the reservoir. Oil will spill during this procedure therefore do not forget to place a rag around the brake lever. Tighten the cover screw until the cover is flush with the reservoir. **Use only the original Torx T7 bolt. Any other screw will lead to leaks, damages and failure of the whole system!**
Tightening torque 0,6 Nm/ 5 in.lbs



11. Remove the syringe and screw in the 3mm allen bleeding screw.
Tightening torque: 2,5 Nm/ 22 in.lbs. Re-position the brake calliper (**tightening torque 6 Nm/ 51 in. lbs.**). Re-install the brake pads and the wheel.

Always pull the lever blade several times (pump) until the brake pads touch the rotor.

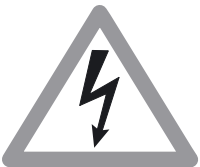

Always check for correct installation by activating the lever blade and checking for eventual leaks.

Never contaminate brake pads with oil or grease this causing permanent loss of brake power! Contaminated pads are definitely dead and must be replaced! A contaminated rotor can be cleaned with MAGURA Disc cleaner, dishwater or alcohol.

11. Trouble Shooting

problem	reason	solution
not enough brake power no pressure point	brake was not run it	break in the brake (page4)
	oil/ lubricants on rotor and/ or pads	clean the rotor with warm dis- hwater or alcohol replace con- taminated brake pads
	air in the system	bleeding the brake (page15) Correct transport (page 5)
	leaking systems	Check hose connections and hose for leaks; replace hose if necessary (pages 14/ 15)
Squealing brake	badly aligned frame	align brake calliper with 0,2mm spacers (page 9)
	Paint/ powder coating on fitting eyelets	remove any paint or powder coating and care for an even contact surface without burrs. (page7)
	Wheel q/r skewer insuffi- ciently tightened	Increase tightening of q/r skewer and mount it on opposite side of calliper.
	Insufficiently tightened wheel spokes	check for an evenly spoked wheel with high spoke tension
contaminated brake pads	carelessness	brake pads must be changed
contaminated rotor	carelessness	clean rotor with MAGURA Disc cleaner, dish water or alcohol
wheel cannot be mounted	Lever blade was pulled with removed wheel	Push back the brake pads with transport device or a flat blade screwdriver. (page12)
rattling noise and rough dece- leration	brake pads worn, holder of pads is wearing the rotor	brake pad change (page 12)
leaking hose or brake	accident, incorrect installation	change hose or defective brake lever or calliper (page 14)



You will find further tips on our website www.magura.com in the FAQ section or in our online forum!! Stay tuned.

12. Accessories



MAGURA disc brake service kit, code: 0721 294

contains everything that you need for bleeding and repairing a brake.
ATTENTION: the kit does NOT include a spare hose!



MAGURA braided hose for all MAGURA disc brakes easily shortened with a cable cutter

Order codes see on page 20.

Watch out for the genuine hose with yellow MAGURA marker!!



Use only genuine MAGURA brake pads!

brake pads Performance Type 6.1 code 0722 418

series pad for maximum brake power.

brake pads Endurance Type 6.2 code 0722 419

with optimized longevity.

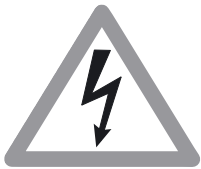

Use only genuine MAGURA accessories! Any parts manufactured by other manufacturers like lever blades, hoses or brake pads have not been tested and approved by MAGURA and consequently nothing can be said about their short and long-term function. Never use those parts! All warranty and product liability claims will be void in case of misuse!

Never change the paint, the finish or the consistence of your brake. This might cause total failure of the whole system with serious consequences for your health!

13. Warranty



MAGURA is giving a **5-year leakproof warranty** on brake levers (master cylinder) and brake callipers **if the brake has been registered on magura.com**. Watch out for the red info sheet in the middle of this manual!

This warranty is void when damage to the brake has occurred from the following:

- abuse
- mixing and matching the brake with parts from other manufacturers
- damage of the exterior finish caused by improper use
- any attempt to disassemble the whole brake
- modifications
- non-factory changes or improper service

We expressly point out that a warranty claim is only accepted with a clear proof of purchase (payment receipt of the dealer!) and recommend to register your brake online on magura.com

14. Spare parts 2009/max. tightening torques

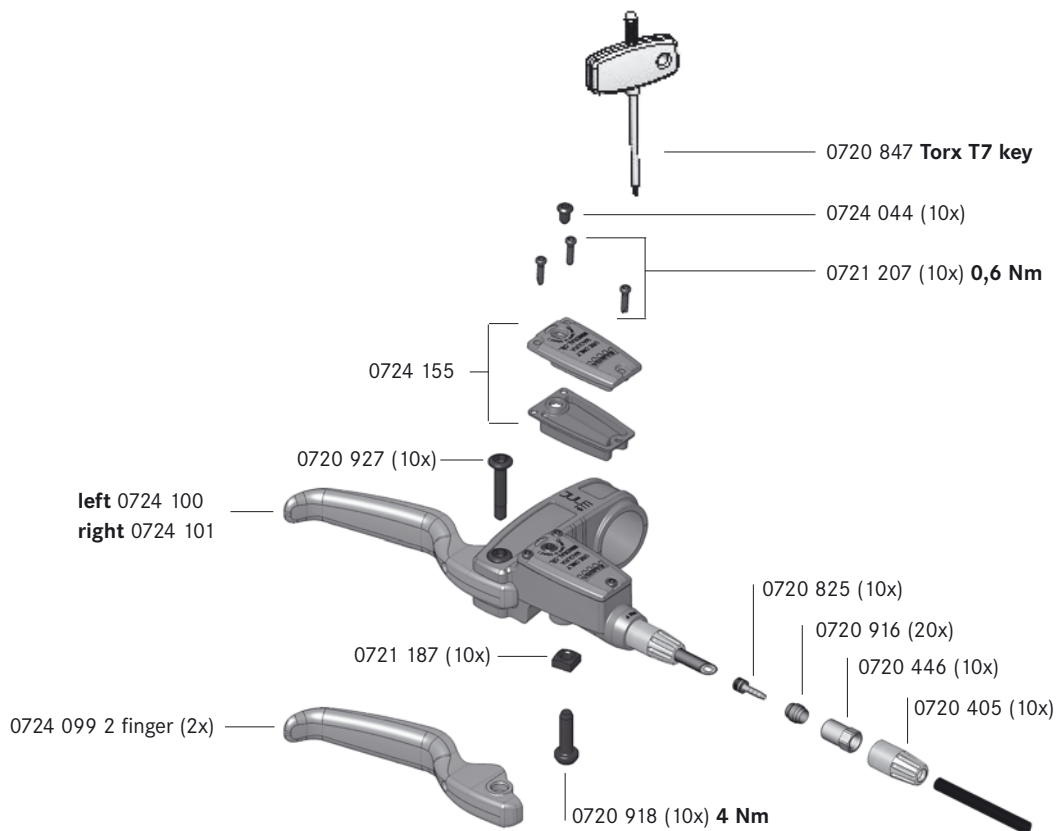

Ventidisc/Centerlock with Lockring

- 203 mm 0722 572
- 180 mm 0722 571
- 160 mm 0722 570

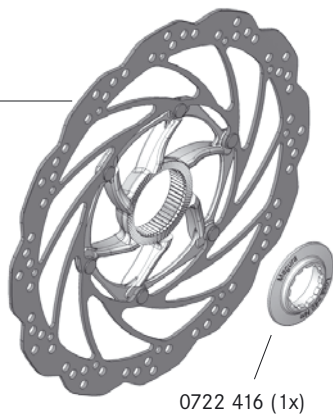

Titanium bolt kits

- 1x M5x18 0737 812
- 6x M5x10 0737 813
- 2x M6x18 0737 811

Ventidisc 6 holes (IS)

- 203 mm 0722 569
- 180 mm 0722 568
- 160 mm 0722 567

0721 204 Torx key T25

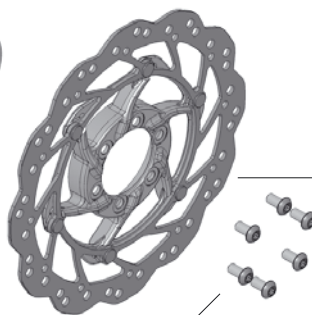

SL Rotor 6 holes (IS)

- 203 mm 0722 332
- 180 mm 0721 456
- 160 mm 0721 455

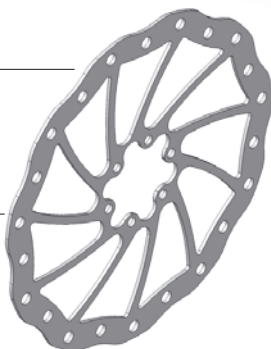

SL Rotor Rohloff Speedhub

- 180 mm 0721 931
- 160 mm 0721 930

- 0722 636 hose 250 cm 6 Nm
- 0721 641 braided hose 250 cm 6 Nm

- 0722 421 (10x)
- 10 x 0720 848 2,5 Nm

0722 530

- 0722 418 Type 6.1 Performance
- 0722 419 Type 6.2 Endurance

Specifications are subject to change without prior notice!

0721 314

Adaptors for all Julie HP models



Adaptor	Rotor diameter/Installation	Order code
Adaptor 5	203/Int. Standard 6" Front	0722 321
Adaptor 6	180/Postmount 6" Front	0722 322
Adaptor 7	203/Postmount 6" Front	0722 323
Adaptor 8	203/Rockshox Boxxer	0722 324
Adaptor 9	203/Int. Standard Rear	0722 325
Adaptor 10	180/Int. Standard Rear	0722 424
Adaptor 11	160/Int. Standard 6" Front 203/Int. Standard 8" Front (Fox 40)	0722 425
Adaptor 12	180/Int. Standard 6" Front 160/Int. Standard Rear	0722 426
Adaptor 26	203 Postmount 7" Front (Thor)	0724 131
Direct Mount	203/Postmount 8" Front (Wotan, Travis etc.) 180/Postmount 7" Front (Thor)	
(no adaptor!)	160/Postmount 6" Front	

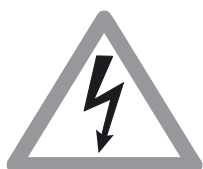

WARNING!

Always make sure, that the fixing bolts are screwed in to a depth of at least 8 mm. This corresponds to around 8 full turns!

Should this not be the case, longer bolts, with a minimum hardness of 8.8 should be used and secured using blue Loctite.



Specifications are subject to change without prior notice !
Visit our website magura.com for further information, tech tips and free online help!!

MAGURA PARTNERS AND SERVICE CENTERS WORLDWIDE

Australia

Steve Cramer Products
phone 03-95871466
fax 03-95872018
sales@stevecramerproducts.com.au

Austria

MAGURA Bike Parts Austria
phone +49-7333-9626-13
fax +49-7333-9626-17
m.haas@magura-bikeparts.de
Service
f.meder@magura-bikeparts.de

Belgium | Vlaanderen

> Sales:
MAGURA Bike Parts
Benelux
phone +49-7333-9626-25
fax +49-7333-9626-17
e.vandepol@magura-bikeparts.de
> MAGURA Tech Support
Benelux
phone +31-653251836
fax +31-842208241
maguratechsupportbenelux@beebikes.com

> Belgium | Wallonie

Sales:
MAGURA Bike Parts
Benelux
phone +49-7333-9626-42
fax +49-7333-9626-17
s.revillet@magura-bikeparts.de
> MAGURA Service Center
France
phone +49-7333-9626-43
fax +49-7333-9626-17
s.revillet@magura-bikeparts.de

Brasil

Ciclovece World Bikes
phone 55-11-3154509
marcelo@ciclovece.com.br

Canada

Orange Sport Supply Inc.
phone 604-990-5110
fax 604-990-5884
info@orangesportsupply.com

Czech Republic

Pell's
phone +420-545242631
fax +420-545242634
magura@pells.cz

Denmark

Borandia APS
phone 47-107172
fax 47-107066
borandia@borandia.dk

Estonia

Hawaii Express
phone 06-398508
fax 06-398566
olev@hawaii.co.nz

Finland

Best Brakes Ky
phone 050-591 5863
fax 019-388485
info@bestbrakes.inet.fi

France

> MAGURA Bike Parts France
phone +49-7333-9626-42
fax +49-7333-9626-17
s.revillet@magura-bikeparts.de
> MAGURA Service Center
France
phone +49-7333-9626-43
fax +49-7333-9626-17
s.revillet@magura-bikeparts.de

Great Britain

> MAGURA Bike Parts UK Ltd.
phone +49-7333-9626-29
fax +49-7333-9626-17
d.coull@magura-bikeparts.de
> MAGURA Service Center UK
phone 01530-837195
fax 01530-811286
service_uk@magura.de

Greece

Nikos Maniatiopoulos
phone 2610-993-045
fax 2610-990-424
aftermarket@idealbikes.net

Hong Kong

MAGURA ASIA Inc.
phone +886-4-23283739
fax +886-4-23283734
service@magura.com.tw

Hungary

Mali Bicycle Technology
phone 01-4207563
fax 01-4205321
mali@mali.hu

Ireland

Beara Bike Trading
phone 064-89134
fax 064-41334
wschmidt@indigo.ie

Israel

Toy House
phone +972-26718282
fax +972-26724521
sales@pedalim.com

Italy

Areab
phone 0438-435550
fax 0438-439847
info@areab.it

Japan

MC International
phone 06-6536-0901
fax 06-6536-0907
mcinter@mx1.alpha-web.ne.jp

Luxemburg

> Sales:
MAGURA Bike Parts
Benelux
phone +49-7333-9626-42
fax +49-7333-9626-17
s.revillet@magura-bikeparts.de
> MAGURA Service Center
France
phone +49-7333-9626-43
fax +49-7333-9626-17
s.revillet@magura-bikeparts.de

Netherlands

> Sales:
MAGURA Bike Parts
Benelux
phone +49-7333-9626-25
fax +49-7333-9626-17
e.vandepol@magura-bikeparts.de
> MAGURA Tech Support
Benelux
phone +31-653251836
fax +31-842208241
maguratechsupportbenelux@beebikes.com

New Zealand

Pure Sports NZ
phone 04-385-1185
chris@puresports.co.nz

Norway

Botolfsen
phone 022-630610
fax 022-970662
info@botolfsen.no

Poland

PolSPORT
phone +48-34-3660456
fax +48-34-3660456
biuro@pol-sport.com

Portugal

LPL-Artigos Desportivos
phone 021-4835354
fax 021-4835362
info@lpl.com.pt

Romania

DAVID SRL-BIKE PARTS SHOP
phone 0213356577
fax 023355948
miu_cornel@yahoo.co

Russia

Chainpower
phone +7-4956850912
fax +7-4953034468
info@chainpower.ru

Singapore

MAGURA ASIA Inc.
phone +886-4-23163388
fax +886-4-2323154030
service@magura.com.tw

Slovakia

AGF Invest s.r.o.
phone 02-62859549
fax 02-62859052
info@agfinvest.sk

Slovenia

Maraton D.O.O.
phone +386-74990870
fax +386-74990872
maraton@siol.net

South Africa

Cycles Africa
phone 011-678-1548
fax 011-678-1548
cunning@mweb.co.za

South Korea

MBS Corporation
phone +82-55-265-9415
fax +82-55-265-9419
kbcco@kornet.net

Spain

> SAT MAGURA: Bicisport
Sólo para reparaciones y servicio!
phone 93-3404480
fax 93-3404480
> Bicicletas Monty
phone 93-6667111
fax 93-6667112
monty@monty.es
> Casa Masferrer
phone 93-8463444
fax 93-8465355
cmcenter@casamasferrer.com
> Comet
phone 943-331393
fax 943-551407
comet@comet.es
> Representaciones
Spinola & Perez
phone 619-702946
fax 93-2317731
c.perez@spinolaperez.com

Sweden

Jaguarverken AB
phone 060-669800
fax 060-669809
info@jaguarverken.se

Switzerland

> Intercycle
phone +41-9266511
fax +41-9266355
info@intercycle.com
> Amsler & Co.
phone 052-6473636
fax 052-6473637
info@amsler.ch

Taiwan

MAGURA ASIA Inc.
phone +886-4-23163388
fax +886-4-23154030
service@magura.com.tw

USA

MAGURA USA
phone 6183952200
fax 6183954711
magura@magurausa.com
www.magurausa.com

THE PASSION PEOPLE

Deutschland | MAGURA Bike Parts GmbH+Co. KG | Heinrich-Kahn-Straße 24 | D-89150 Laichingen | info@magura-bikeparts.de
Hotline | Helpdesk | Phone 09001-648124* | Fax 07333-962651 | service@magura.de
*(41 ct. pro Minute, täglich 09.00 - 12.00 h, 12.30 - 15.15 h)
www.magura.com

