

# ThevoSiiS

Ⓞ GB	User manual – ThevoSiiS.....	10
------	------------------------------	----





(1)



(2)



(3)



(4)

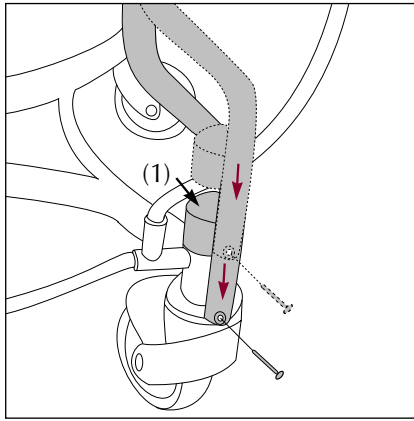

(5)

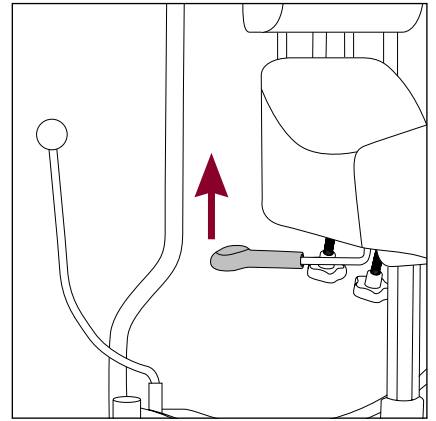

(6)

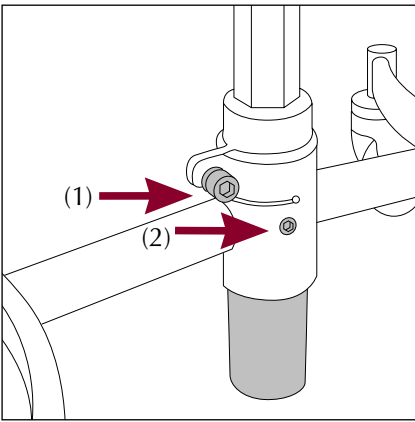

(7)

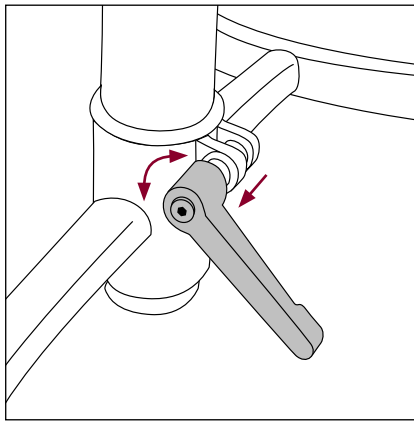

(8)

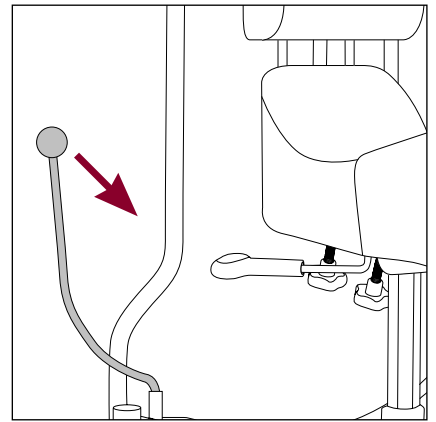

(9)

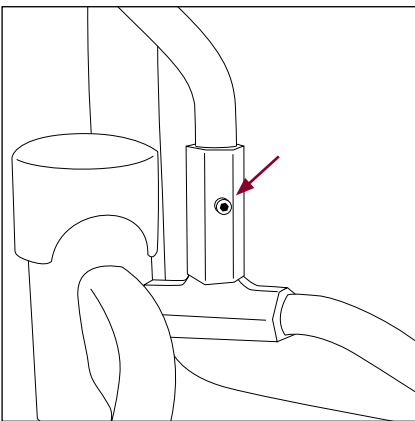

(10)

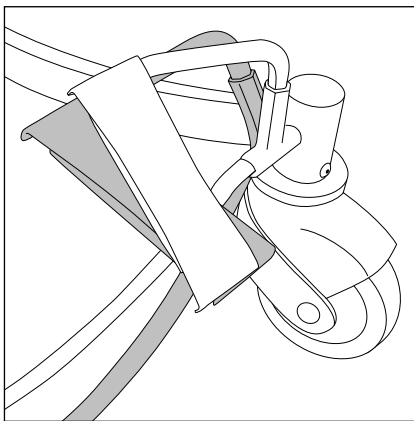

(11)

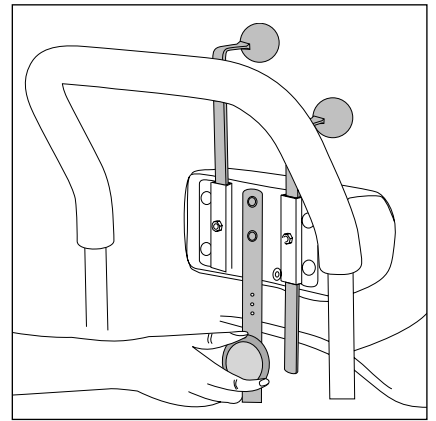

(12)

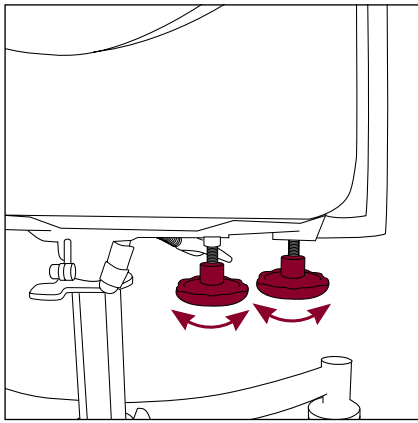

(13)

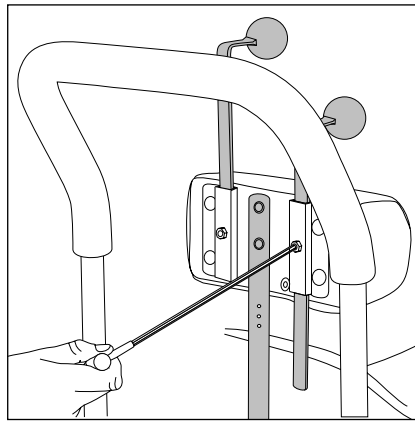

(14)

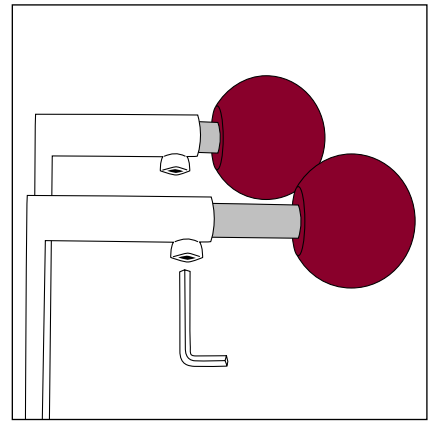

(15)



## Dear user of ThevoSiiS therapy chair,

Thank you very much for choosing ThevoSiiS therapy chair of Thomashilfen. This seat with integrated impulse sensors was manufactured according to the highest quality standards to ensure a long operating life.

Please read this user manual carefully before use. It contains important information for a correct and simple handling of your ThevoSiiS therapy chair.

If you have any questions or comments on ThevoSiiS, please do not hesitate to contact us.

## Contents

	Page
Purpose and use .....	11
Clinical pictures and basic requirements.....	11
Basic requirements for the use of a ThevoSiiS therapy chair .....	11
Safety related checks and maintenance intervals.....	11
General safety instructions.....	11
Properties of ThevoSiiS therapy chair.....	12
Positioning recommendation for ThevoSiiS therapy chair .....	12
Assembly.....	13
Adjustment options.....	13
Technical data .....	14
Cleaning and care instructions.....	14
Terms of guarantee / CE mark .....	14

## Purpose and use

ThevoSiiS therapy chair provides a stable and centered sitting position for the user. It gives a minimum of support in order to induce an active holding task.

The floor contact of the feet, the firm seat surface, and the back rest give clear perception information and a sensible orientation. The user finds their body center and leads their arms and hands towards this center.

Application studies made with children and adult users showed an improved hand-hand and eye-hand-coordination, and to some extent improved mouth closing and swallowing results. These abilities provide a vital edge in different areas, e.g. at home, in institutions or at home.

The users appear more awake and significantly more involved in their environment and situation. The constant impulses, which lead to an upright sitting posture awaken pride and strengthen their self-esteem.

## Clinical pictures

- Cerebral apraxia (diplegia, tetraspasticity, single-side problems)
- Cognitive processing deficiencies / ADD
- Tonus dysregulation (so-called "floppy" and „hypertonus" users)

## Basic requirements for the use of a ThevoSiiS therapy chair

- The user must have a minimum of support capacity in the legs.
- The user must have a minimum of trunk control which is activated by a corresponding stimulant (e.g. compensating movements, forward support of the arms) and can be changed towards normosone.

## Safety checks and maintenance intervals

We recommend adjusting the ThevoSiiS growths settings at least every 3 months to best fit the user. If necessary, let your therapist help. Check all control elements and fastening screws monthly.

## Please observe the following safety instructions:

- Please check for proper operation immediately after receipt of ThevoSiiS therapy chair
- Make sure with the help of a doctor or therapist that the product is suitable for the user.
- Please make sure to re-tighten the screws after each adjustment.

**Caution:** Wet wheels may affect the braking action. Apply the brake when stopping or during transfer to prevent inadvertent rolling.

- Do not exceed the maximum size and weight capacity of ThevoSiiS therapy chair. Please refer to the literature for specification details (see technical data).
- On uneven ground and on overcoming thresholds there is a risk for ThevoSiiS therapy chair to tip over.
- Never leave the user unattended to minimize the risk of injuries.
- Please keep packaging material away from children to avoid the risk of choking.
- Only one child or adult user at a time is allowed to use ThevoSiiS therapy chair.
- When lifting the chair, make sure to hold it at tightly welded or tightly screwed competent parts only.
- High solar radiation may lead to high surface temperatures on the dark upholstery material.
- Be careful not to harm yourself when adjusting the height and depth of the iliac crest support or the impulse generators.

## Properties of ThevoSiiS therapy chair

### Seat

- The firm seat block provides a maximum of sensory stimulation to the user.
- The long seat surface serves to facilitate forward placement of the arms (stabilization, creating symmetry, regulating tone); in addition, interim changes to spinal cord strain can be accomplished by supporting the arms on the seat block.
- The long seat surface serves to facilitate forward placement of the arms.
- The seat block sets the physiological body posture.
- The sloped seat surface at the rear end of the seat block area tilts the pelvis slightly, so the spine can be straightened.
- Ergonomic seat block design.

### Back

- The small, firm iliac crest support with low body contact serves for stabilization.
- The iliac crest support is individually adjustable to the user in height and depth.
- The punctiform impulse generators communicate orientation via the position of the back and at the same time have a stimulating effect on the body straightening and orientation process. The height can be adjusted to the individual need of the user.

**Hint:** ThevoSiiS M and ThevoSiiS H feature a depth adjustment of the impulse generators.

### Base frame

- The seat height adjustment is infinitely variable, allowing the legs to be positioned correctly.
- Versatile adjustment options for individual customization to the person and particular situation are offered.
- The user can independently operate the lever brake and height adjustment, providing them with a certain degree of autonomy.

**Hint:** Not possible with ThevoSiiS M.

- The base frame guarantees good rolling functionality and a lot of leg room which, if applicable, offers sufficient freedom of movement during the initiation of a contra lateral gait pattern (alternately setting down the feet) from a seated position.
- The therapy chair is tilt resistant when standing solid on plane ground.
- The push bar provides good conditions for the chair to be pushed by an assistant, even over longer distances.
- The user can also use the bar as a "handle" for transfer and movement.

**Hint:** ThevoSiiS M is delivered without push bar.

## Positioning recommendation for ThevoSiiS therapy chair

### 1. step (Img. 1)

The feet must always have firm contact with the floor and, in addition, be in a symmetrical position.

### 2. step (Img. 2)

Height adjustment – in order to accomplish the correct positioning of the knee and hip joints. The height of the seat has to be adjusted so the user has floor contact with their feet. In practice, a knee angle and hip angle above 90° has proven itself and achieved good body straightening results.

### 3. step (Img. 3)

Adjusting the body straightening and orientation impulse using the small, firm iliac crest support. It is positioned at the lower iliac crest – often in direct contact with this region. This iliac crest element can be adjusted individually in height and depth, as described in the brochure.

### 4. step (Img. 4)

Positioning the punctiform impulse generators: Each user reacts to individual stimulation points located between the lower part of the thoracic spine and below the shoulder blades. The impulse generators must be adjusted at height level of these points to initiate straightening of the trunk upon contact with the impulse generators.

## Assembly

Your ThevoSiiS therapy chair is delivered completely assembled except for the push bar. The push bar is placed onto the cylinders above the back wheels. Attach the push bar with the screws and washers provided. The holes above the back wheels (Img. 5, 1) are closed using the cover caps enclosed.

**Hint:** ThevoSiiS M is delivered without a push bar.

## Adjustment options

The special needs of the user require an individual adjustment of the ThevoSiiS therapy chair. Therefore, you should adjust the ThevoSiiS therapy chair consulting your doctor or therapist, until the best possible straightening of the user is reached.

### Seat height (Img. 6)

Pull the lever on the right underneath the seat block upwards to individually adjust the height. When the desired height is reached, release the lever.

Additionally, the gas spring can be adjusted by another 10 cm / 3.9" using an Allen key (Img. 7, 1). This facilitates overcoming e.g. high thresholds. To prevent a twisting of the seat the hexagon socket screw (Img. 7, 2) needs to be tightened on all models at any time.

**Tip:** To remove the seat, loosen both screws.

### Height adjustment ThevoSiiS M (Img. 8)

To adjust the seat height, please loosen the clamp lever and the Allen head screw on the tube retainer. As soon as the required height is set, please tighten the screws back up.

**Hint:** By lifting the clamp lever, it can easily be moved in the desired position.

### Brake (Img. 9)

To brake the rear wheels, press the lever forwards. To release the brake, pull the lever backwards again.

**Hint:** The lever can be mounted on either left or right side of the base frame. Simply loosen the screw, using the Allen key, and pull the lever out. Remove the cover cap on the other side, refit the brake lever and tighten with the screw.

### Brake ThevoSiiS M (Img. 11)

ThevoSiiS M features a foot brake as standard. To activate the brake, simply press the tread forwards with the foot. To release the break, move the tread backwards. The foot brake can only be used on the right side. In addition, there is the option to fit a hand brake on the left in order to provide the child with their own braking facility.

**Hint:** The foot brake can also be ordered as accessory for the other models.

### Iliac crest support (Img. 12)

To adjust the height of the iliac crest support, loosen the hand screw and re-tighten after adjustment.

### Depth adjustment of the Iliac crest support (Img. 13)

The depth of the iliac crest support can be adjusted underneath the seat. Loosen the hand screws and individually adjust the depth. Afterwards re-tighten the hand screws again.

### Impulse generators (Img. 14)

To adjust the impulse generators, loosen the Allen screws and adjust the desired height by either pulling the impulse generators upwards or pushing them downwards. Afterwards re-tighten the screws.

### Depth adjustment of the impulse generator for ThevoSiiS M and ThevoSiiS H (Img. 15)

Loosen the Allen head screw with an Allen key. Position the impulse generators at correct height and re-tighten the screws.

**Hint:** The depth adjustable impulse generators can also be ordered as accessory for the other models.





## Technical data

ThevoSiiS	size 1	size 2	P	H	M	S
<b>Item code</b>	8300	8305	8306	8307	8301	8308
<b>Seat height</b>	42 - 55 cm / 16.5 - 21.7"	42 - 55 cm / 16.5 - 21.7"	49 - 68 cm / 19.3 - 26.7"	53 - 80 cm / 20.9 - 31.5"	32 - 40 cm / 12.6 - 15.7"	42 - 55 cm / 16.5 - 21.7"
<b>Seat width</b>	19 cm / 7.5"	19 cm / 7.5"	22 cm / 8.7"	19 cm / 7.5"	15 cm / 5.9"	16 cm / 6.3"
<b>Impuls generators</b>						
- height adjustment	18 cm / 7.1"	18 cm / 7.1"	18 cm / 7.1"	27,5 cm / 10.8"	27,5 cm / 10.8"	18 cm / 7.1"
- depth adjustment				3,5 cm / 1.4"	3,5 cm / 1.4"	-
<b>Iliac crest support</b>						
- height adjustment	8 cm / 3.2 "	8 cm / 3.2 "	8 cm / 3.2 "	8 cm / 3.1"	8 cm / 3.1"	8 cm / 3.1"
- depth adjustment	3.5 cm / 1.4"	3.5 cm / 1.4"	3.5 cm / 1.4"	3.5 cm / 1.4"	3.5 cm / 1.4"	3.5 cm / 1.4"
<b>Overall dimensions</b> (w x h x d)	54 x 88 x 54 cm 21.3 x 34.7 x 21.3"	60 x 88 x 56 cm 23.6 x 34.7 x 22"	60 x 88 x 56 cm 23.6 x 34.7 x 22"	60 x 88 x 56 cm 23.6 x 34.7 x 22"	54 x 50 x 68 cm 21.3 x 19.7 x 26.8"	60 x 88 x 56 cm 23.6 x 34.7 x 22"
<b>Push bar height</b>	88 cm / 34.7"	88 cm / 34.7"	88 cm / 34.7"	88 cm / 34.7"	-	88 cm / 34.7"
<b>Wheel size</b>	10 cm / 3.9"	10 cm / 3.9"	10 cm / 3.9"	10 cm / 3.9"	10 cm / 3.9"	10 cm / 3.9"
<b>Wheel distance front</b>	53 cm / 20.9"	58 cm / 22.8"	58 cm / 22.8"	58 cm / 22.8"	53 cm / 20.9"	58 cm / 22.8"
<b>Wheel distance rear</b>	54 cm / 21.3"	55 cm / 21.7"	55 cm / 21.7"	55 cm / 21.7"	54 cm / 21.3"	55 cm / 21.7"
<b>Max. weight capacity</b>	50 kg / 110 lbs	120 kg / 265 lbs	120 kg / 265 lbs	120 kg / 265 lbs	22 kg / 49 lbs	120 kg / 265 lbs
<b>Weight</b>	13 kg / 29 lbs	14 kg / 31 lbs	14 kg / 31 lbs	15 kg / 33 lbs	11 kg / 24 lbs	14 kg / 31 lbs
<b>Body size</b>	max. 135 cm / 53.2"	130 cm / 51.2" and taller	140 cm / 55.1" and taller	145 cm / 57.1" and taller	max. 125 cm / 49.2"	135 cm / 53.2" and taller

## Cleaning and care instructions

The base frame of ThevoSiiS therapy chair is manufactured from high-quality steel and aluminum tubing, which can be cleaned using commercially available nontoxic soap (neutral soap). The seat upholstery can be wiped with a soft, if necessary, damp cloth.

## Terms of guarantee / CE mark

Thomashilfen is certified in accordance with the ISO standards DIN EN ISO 13485:2003 and guarantees the quality of the product supplied. Both material selection and processing meet the very highest of manufacturing standards. Every single part has been subjected to a final inspection.

Thomashilfen offers you a guarantee of 3 years for all frame parts, commencing on the date of purchase. This guarantee incorporates all claims which influence functionality. Damage due to improper use (e.g. overloading) or natural wear and tear are excluded.

ThevoSiiS therapy chair meets the requirements of the European EN 1888 standard and is provided with a CE marking. Enjoy using your ThevoSiiS therapy chair!





Member of the International  
Support Association for the  
Rehabilitation of Children and Youths e.V.

Thevo by   
Thomashilfen

The logo for Thevo by Thomashilfen features a stylized, multi-colored arc (yellow, orange, red, blue) above the text. The word "Thevo by" is in a smaller, red, sans-serif font, and "Thomashilfen" is in a larger, blue, sans-serif font.