

Přejděte na FW 2.04

K nové verzi FW je dostupný také nový manuál
(http://cpx.cz/dls/WP54AG_linux/UsersManula_WP54AGv1_3c_mSSID.pdf)

Mezi hlavní změny patří náhrada WDS které nemohlo fungovat s moderními metodami zabezpečení (WPA, WPA2) za architekturu ROOT AP, Transparent Client, Repeater.

Jak tedy na změnu WDS?

Při realizaci Point-to-Point případně Point-to-MultiPoint.
Zapněte na AP volbu Act as RootAP (viz. str. 114)
Na protistraně uveďte zařízení do modu Transparent Client
Schéma viz. str. 10 Klienti ve spodní části obrázku jsou připojeni kabelem přes switch (v manuálu je chyba)

Mód Repeater

V tomto modu snadno rozšíříte stávající dosah zařízení viz. str. 12
Zařízení může přijímat signál s SSID RootAP a vysílat s jiným SSID.
Klienti mohou být připojeni jak přes WiFi tak přes ethernetový port zařízení.

Mod Gateway

Při prvním přepnutí do modu Gateway zřízení očekává na ethernetovém portu DHCP server
pak se na něj připojíte [http://IP z DHCP serveru:88](http://IP_z_DHCP_serveru:88)
[https://IP z DHCP serveru:88](https://IP_z_DHCP_serveru:88) pokud jste změnili Web Management Setup na HTTPS (SSL)

MAC Filtering

MAC Filtering ve verzi 2.03 a novějším NEFILTRUJE MAC z ethernetového portu, pouze MAC z WiFi části. Nesnaží se už tedy filtrovat i MAC adresy za dalšími rádii.

Nová verze FW podporuje také SNMP Traps

FAQ

===

Co je multi-SSID (mSSID)?

Tato vymoženost umožňuje AP s jedním radiovým rozhraním vysílat více než jedno SSID.

K čemu je mSSID dobré?

MSSID umožňuje zvýšit stupeň zabezpečení sítě.
Každé SSID může mít nastavenou jinou úroveň zabezpečení a podle té jsou pak klienti umísťováni do VLAN a to vše bez nutnosti více AP.

Příklad:

1. SSID "volne" bude mít nastaveno zabezpečení na NONE klienti asociovaní k takovému to SSID budou zařazeni do VLAN 10 a na routeru pak povelen pouze odchozí port 80 (dostanou se pouze na web)
2. SSID "bezpecne" zabezpečení WPA2-PSK klienti asociovaní k tomuto SSID budou ve VLAN1 a pro tuto bude na routru nastaven volný přístup do internetu.

Shrnutí: mSSID je rozšíření VLAN i do bezdrátové sítě.

Jak na upgrade na mSSID?

Pokud používáte FW 1.3 a novější tak přechod na mSSID FW (2.03) bude bezproblémový.

Jestliže u zařízení pracují v modu PtP nebo PtMP pak NELZE zachovat stávající konfiguraci.

Toto je způsobeno jiným pojetím PtP a PtMP modu, ve FW 2.03 a novějších je podle IEEE 802.11h

Můžu po upgrade na mSSID (FW 2.03) používat pouze jedno SSID?

Ano, toto je možné. Dokonce nebudete muset provést přenastavení (pokud verze vašeho stávajícího FW je 1.3x a novější)

A co MAC Filtering?

Nemusíte se strachovat své nastavení (pokud máte FW 1.3x a novější)

Pseudo VLAN s Per Group (Per Node) a upgrade na mSSID?

Pokud provedete upgrade s takovým to nastavením bohužel přijdete o nastavení. Per Node nastavíte v menu WLAN Setup - Advanced - Station Isolation. (platí pro všechna SSID)

Per Group nastavíte tak že vytvoříte tolik VAP (SSID) kolik bylo skupin a jednotlivé MAC přidáte do WLAN Setup - MAC Filtering ke konkrétnímu SSID (Edit)

Používám WDS jak upgradovat na mSSID?

Pokud používáte WDS a chcete upgradovat na mSSID (maximální stupeň zabezpečení u WDS je WAP) pak použijte pro klienty modu Repeater.

Bohužel není možné při upgrade zachovat spojení a konfiguraci. Je třeba se ke každému zřízení připojit a změnit jeho nastavení.

----- níže originál rozšířené FAQ výrobce -----

Updating from standard WP54 and WPP54 firmware to new multi-ssid firmware.

Multi-ssid firmware support for WP54 and WPP54 will be available from firmware v2.0 and higher.

**** Warning:-**

The following wireless operation modes are changed in mssid firmware.

- a) **PtP and PtMP**
- b) **WDS**

If APs are configured and running these modes updating to the **mssid firmware will cause wireless disconnection.**

You need to connect individually with each AP to update the mssid firmware then reconfigure them with to new setup.

See the User Manual for setup instructions.

The new PtP and PtMP method in mssid firmware is compliant with 802.11h.

User do not need to update to the mssid firmware if their existing PtP and PtMP modes work fine for them and the respective country authority.

FAQ

Q1) What is mssid ?

multi-ssid (mssid) as the name suggest allows an access point (AP) with a single radio card support to more than one ssid.

Q2) What can you do with mssid connection ?

The application of mssid is to provide better security with multi network paths connection from a single AP to multiple VLAN network segments of switch on the local area network.

See an application of network setup illustration below.

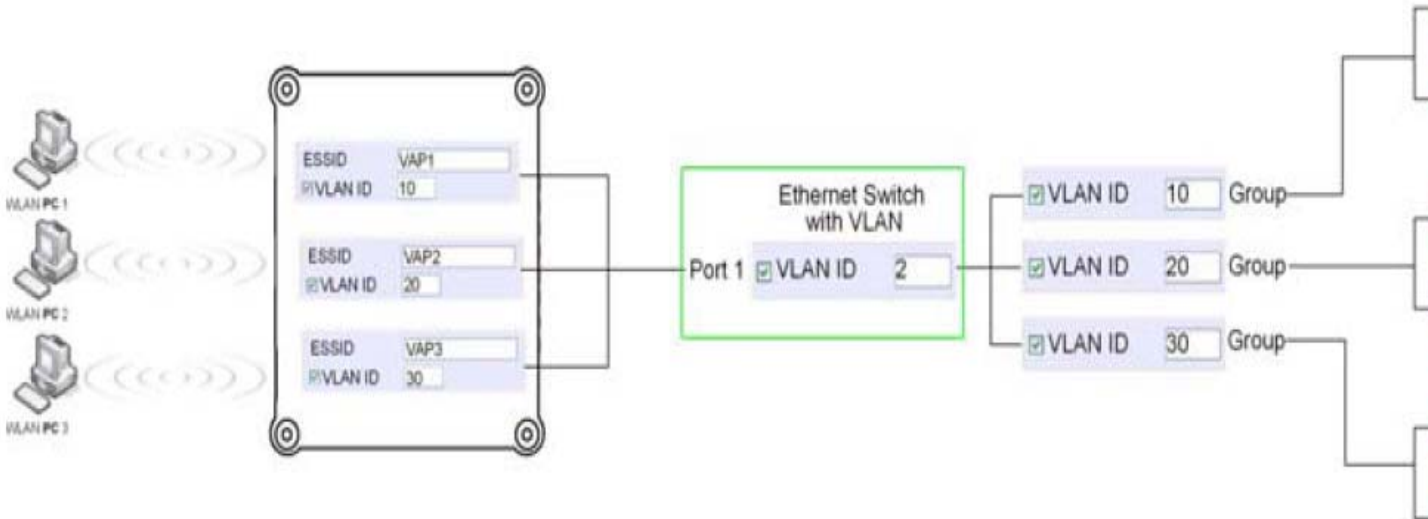

e.g. Virtual AP with SSID VAP1 has VLAN ID 10 and enabled WPA-PSK wireless security will be channeled to port 2 and 3 where the internet sharing router is connected.

Virtual AP with SSID VPA2 has VLAN ID 20 and enabled WPA-EAP and connected to a radius server will be channeled to port 5 and 6 which are connected to the firewall of the internal local area network.

Q3) Can I update my WP54G or WP54AG to this mssid firmware ?

Yes. You can retain your WP54G or WP54AG configuration when you update to the mssid firmware if the current firmware running is v1.3x and above.

If AP is running the following configuration setup updating to the mssid firmware the configuration will be affected.

a) If AP is running as PtP (Point-To-Point) or PtMP (Point-To-MultiPoint) mode.

The reason it can't retain the configuration is because mssid use a new PtP and PtMP connecton setup method call RootAP and Transparent Client. This method is compliant with 802.11h standard.

b) AP is running very old firmware v1.2x and below.

Q4) Can I update to mssid firmware but setup only one ssid connection ?

Yes. mssid firmware when setup with on ssid will contiune to operate the same as previous single ssid firmware.

Infact, if your existing AP firmware isrunning v1.3x, after updating to mssid it retain and contiune to run the previous configuration. No reconfiguration necessary.

Q5) I have a MAC Filtering table set from a previous firmware. Will update to mssid cause the MAC table to be lost ?

No, if your firmware is v1.3x and higher, update to mssid firmware will retian all entries in the MAC table.

But if you switch back from mssid to the previous sssid firmware, the MAC table will be lost.

Q6) I have Pseudo VLAN for Per Group enabled. Will update to mssid firmware still support those wireless clients with their MAC address listed in Per Group ?

mssid firmware has replaced Pseudo VLAN and integrated it into the VAP (Virtual AP) and MAC Filtering.

Thus Pseudo VLAN with its VLAN ID and MAC listing will be lost after update to mssid firmware.

Refer to the user manual on how to create new VAP with VLAN ID and MAC Filtering.

Similarly, Per Node (control to isolate wireless station in AP) being part of Pseudo VLAN will also be lost.

This option can be enabled again from the option, "Station Isolation" in VAP setup page.

Q7) I have WDS setup in my network. Will mssid still support this ?

WDS has the limitation that it can only support WEP security key.

To support higher wireless security it was replaced with Repeater mode in mssid firmware.

Thus updating to mssid will disconnect the WDS links and connections with the rest of the APs.

Its recommended to connect directly to each AP to update the firmware then set to Repeater mode and configure it before updating the next AP. This way, you can build back the tree connections.

Refer to the user manual for more details instructions on the setup.

If you do not need the higher wireless security support you do not need update to the mssid firmware.

Q8) I have 2 units WP54AG installed at a site about 2KM from each other and running PtP modes. Should I update to mssid firmware ? Can I do it from one location to update the firmware like I do with the current single ssid firmware ?

The setup for PtP and PtMP for mssid firmware is different the current sssid firmware.

After mssid firmware start up, link between the 2 AP will be lost.

The recommended way is to setup 2 similar model units in the office. Load the mssid firmware and create the new PtP / PtMP configuration using the actual parameters of the 2 units on site that you will update.

After tested the connection to be working in the office, backup the configuration to file for each unit.

Go to site number one to update the mssid firmware and then restore config for site. Then go the next site and do the same.

When both APs are up again the network at both side should be connected with the new PtP setup.

**** Note: If existing PtP connection is running well, its not necessary to update to the mssid firmware.**

Unless you have the following concerned:

a) Current firmware PtP is not compliant with 802.11h and the authority of your country requires to change.

b) Current firmware PtP wireless security only support WEP key and you are very concerned of been hacked.

Q9) WPA security in PtP is very usefull , so in this version of multiSSID fw we can use WPA in PtP now ?

PtP and PtMP in mssid use new setup method (RootAP and Transparent Client) and support from WEP to WPA2

Q10) In multi SSID - can every SSID have it's own IP address, 4 vlans = 4 IP address ? (like in StarOS or Monowall (FreeBSD))

No, current mssid use VLAN (Virtual AP) to isolate each VAP connection to ethernet network.

Basically as an AP, IP addr is transparent for wireless client. Any client with any IP can already connect to AP to access the network.

We added VLAN support for each VAP to further isolate the wireless connect that goes to different VLAN segment of switch network.

This is a better security connection for wireless <--> Ethernet network. See attached FAQ.

Using different IP subnet will require more powerful CPU as it will need to handle lots of packets routing.

We only support this in higher power CPU model like the hardware of WP18.

We will have such product with mssid and IP soon.

Q11) Is this new PtP method slower or faster than in previous fw version ?

The old PtP method will be slower. You can try the new PtP method. It should perform better. You should be able to get 2.3MB/s with NetTest.