



**INSTANT RECOVERY[®]
SPARK IGNITION
GAS FRYER - SERIES 2014**

MANUAL

IMPORTANT:

THE USER'S MANUAL PROVIDES SPECIFIC OPERATING INSTRUCTIONS FOR YOUR MODEL. USE THE INSTANT RECOVERY[®] GAS FRYER ONLY AS INSTRUCTED IN THIS MANUAL.

KEEP A COPY OF YOUR BILL OF SALE.

The date on the bill establishes the warranty period should service be required. If service is performed, it is in your interest to obtain and keep all receipts.

KEEP THIS MANUAL FOR TRAINING NEW PERSONNEL.

Record the Serial number and Model number of this Instant Recovery[®] Gas Fryer in the spaces provided. **Keep these numbers for future reference.**

SERIAL NUMBER

MODEL NUMBER

Keating commercial fryers are not intended for household use.

As continuous product improvement occurs, specifications may be changed without notice.

1-800-KEATING | keatingofchicago.com

NOTE:

PURCHASER SHOULD POST IN A PROMINENT LOCATION INSTRUCTIONS TO BE FOLLOWED IN THE EVENT THE USER SMELLS GAS. THIS INFORMATION SHALL BE OBTAINED BY CONSULTING THE LOCAL GAS SUPPLIER.

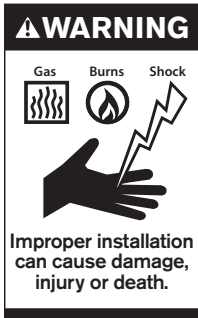

⚠ WARNING

Improper installation, adjustment, alteration, service or maintenance can cause property damage, injury or death. Read the installation, operating and maintenance instructions thoroughly before installing or servicing this equipment.



FOR YOUR SAFETY:

Do not store or use gasoline or other flammable vapors or liquids in the vicinity of this or any other appliance.

⚠ WARNING

IF NOT INSTALLED, OPERATED AND MAINTAINED IN ACCORDANCE WITH THE MANUFACTURER'S INSTRUCTIONS, THIS PRODUCT COULD EXPOSE YOU TO SUBSTANCES IN FUEL OR IN FUEL COMBUSTION WHICH CAN CAUSE DEATH OR SERIOUS ILLNESS AND WHICH ARE KNOWN TO THE STATE OF CALIFORNIA TO CAUSE CANCER, BIRTH DEFECTS OR OTHER REPRODUCTIVE HARM.

⚠ WARNING

PROPANE GAS MAY EVENTUALLY LOSE ITS ODOR AND PRECAUTIONS SHOULD BE TAKEN TO ASSURE THAT PROPANE GAS IS NOT PRESENT EVEN THOUGH YOU DO NOT DETECT AN ODOR. IF THERE IS ANY DOUBT, YOU SHOULD CALL YOUR LOCAL PROPANE GAS SUPPLIER FOR ASSISTANCE.

THE EQUIPMENT IS TO BE INSTALLED TO COMPLY WITH THE BASIC PLUMBING CODE OF THE BUILDING OFFICIALS AND CODE ADMINISTRATORS INTERNATIONAL, INC. (BOCA) AND THE FOOD SERVICE SANITATION MANUAL OF THE FOOD AND DRUG ADMINISTRATION (FDA).



■ TABLE OF CONTENTS

Important Safety Instructions	i	Cooking	6
INTRODUCTION	1	Timer Programming	7
INSTALLATION		Oil Breakdown	7
Damage During Shipment	1	Draining.....	7 - 8
Drop-In Fryer Counter Cut-Out/Installation	2	Cleaning and Boil-Out	8 - 9
FIRST STEPS		OPERATOR SELF HELP CHECK LIST	9
Positioning	3	PREVENTATIVE MAINTENANCE	
Ventilation	3	Preventive Maintenance Chart	10
National Code Requirement	3	Hi-Limit Check Bi-Monthly.....	10
Leveling.....	3	Thermostat Calibration	10
Restraining Devices.....	3 - 4	Thermostat Bulb Positioning.....	10 - 11
Electrical Connection.....	4	WARRANTY REPAIRS	11
Gas Connectors & Pipe Size.....	4	Troubleshooting.....	12 - 14
Flexible Gas Connectors & Quick Disconnect Devices	4	Ordering Parts.....	14
PLACING YOUR KEATING FRYER IN OPERATION		Parts List.....	15 - 24
Filling	5	Wiring Diagrams	25 - 31
Lighting	5 - 6	Warranty Information	32
Shutdown	6		

■ INTRODUCTION

Instructions in this manual should be read thoroughly before attempting to operate this Keating Gas Fryer. All installation and service on Keating equipment must be performed by qualified, certified, licensed and/or authorized installation or service personnel.

Operating information for Keating equipment has been prepared for use by qualified and/or authorized personnel.

Keating equipment is made in the USA and has American sizes of hardware. All metric conversions are approximate.

■ INSTALLATION INSTRUCTIONS

Proper installation will assure top performance. Alterations of any kind to your equipment will void the warranty. Before uncrating, check equipment carefully for damage.

IF EQUIPMENT ARRIVES DAMAGED

Keating does not assume responsibility for loss or damage incurred in transit.

IMPORTANT

This merchandise has been thoroughly inspected and carefully packed before leaving our plant. Responsibility for its safe delivery was assumed by the carrier at the time of shipment. Claims for loss or damage to the contents should, therefore, be made upon the carrier, as follows:

CONCEALED LOSS OR DAMAGE

Concealed loss or damage means loss or damage which does not become apparent until the merchandise has been unpacked. The contents may be damaged in transit due to rough handling even though

the carton may not show external damage. When the damage is discovered upon unpacking, make a written request for inspection by the carrier's agent within fifteen days of the delivery date. Then file a claim with the carrier since such damage is the carrier's responsibility. By following these instructions carefully, we guarantee our full support of your claims to protect you against loss from concealed damage.

VISIBLE LOSS OR DAMAGE

Any external evidence of loss or damage must be noted on the freight bill or express receipt, and signed by the carrier's agent. Failure to adequately describe such external evidence of loss or damage may result in the carrier refusing to honor a damage claim. The form required to file such a claim will be supplied by the carrier.

DO NOT RETURN DAMAGED MERCHANDISE TO KEATING. FILE YOUR CLAIM AS STATED ABOVE.

SAFETY PRECAUTIONS

⚠️ WARNING

THIS SYMBOL WARNS YOU THAT SERIOUS BURNS OR OTHER INJURIES MAY RESULT IF SAFETY INSTRUCTIONS ARE NOT FOLLOWED.

- This service manual should be retained in a safe place for future reference. The installation of your new fryer must conform to local codes or in the absence of local codes, with the current National Fuel Gas Code ANSI Z223.1/NFPA 54 (latest edition), Natural Gas Installation Code CAN/CGA-B149.1 or Propane Installation Code CAN/CGA-B149.2.
- Your ventilation hood, when installed, must conform to the current ANSI/NFPA 96 standard (latest edition).
- No frame or restriction shall be constructed around the fryer that will restrict air movement into the fryer's combustion area or prevent proper ventilation.
- Keating fryers are designed to operate on the gas fuel specified on the serial plate and must not be operated with another gas fuel. They cannot be converted to another gas fuel by turning or engaging a switch.

⚠️ WARNING

DO NOT STORE OR USE GASOLINE OR OTHER FLAMMABLE VAPORS AND LIQUIDS IN THE VICINITY OF THIS OR ANY APPLIANCE.

You will post, in a prominent location, instructions to be followed in the event the user smells gas. This information shall be obtained from your local gas supplier.

IMPORTANT: IN THE EVENT A GAS ODOR IS DETECTED, SHUT DOWN UNIT AT MAIN SHUT-OFF VALVE AND CONTACT THE LOCAL GAS COMPANY OR GAS SUPPLIER FOR EMERGENCY SERVICE.

- You must maintain this appliance free and clear from combustibles.
- You must maintain the following minimum clearances from combustible and non-combustible construction:

MINIMUM CLEARANCE

CONSTRUCTION CLEARANCES		
	COMBUSTIBLE	NON-COMBUSTIBLE
BACK	6"	0"
RIGHT SIDE	6"	0"
LEFT SIDE	6"	0"

SUITABLE FOR NON-COMBUSTIBLE FLOORS

DROP-IN FRYER COUNTER CUTOUT/INSTALLATION

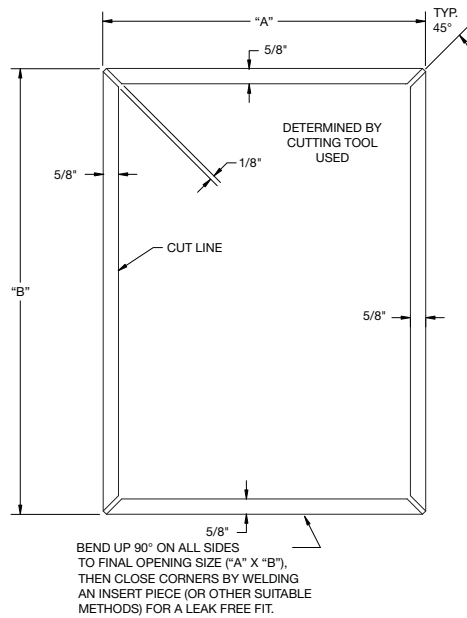

FRYER	"A"	"B"
10x11 DI	13"	21 1/2"
10x11 DI E2000	13"	22"
14 DI	16"	23 1/2"
18 DI	20"	29"

INSTALLATION NOTES

1. All Drop-In Fryers must be 16" from any open flame.
2. Fryer must be located no more than 5" from counter top front.
3. Cabinet must be reinforced to support full weight of fryer in use (Fryer, oil, food, etc.).
4. Fryers must be properly ventilated and located under an exhaust hood.

DROPPING THE FRYER INTO THE COUNTER TOP

It is only necessary to place the fryer in such a position that the front edge overlaps the front raised edge of the opening.

Push the fryer forward as far as it will go holding the fryer on approximately a 15° angle, and then drop the rear of the fryer into its proper position lowering it down gently so you do not deform the table or equipment stand.

■ FIRST STEPS

POSITIONING

Keep appliance area free and clear of any combustibles. Position the Keating Gas Fryer 6 inches (152mm) from any combustible material. A minimum of 24 inches (610mm) should be provided at the front of the Keating Gas Fryer for servicing and proper operation. Air for combustion enters the fryer from the bottom of the cabinet and the bottom of the control panel.

DO NOT BLOCK BOTTOM OF KEATING INSTANT RECOVERY® GAS FRYER CABINET. DO NOT OBSTRUCT FLUE.

Your Keating Instant Recovery® Gas Fryer is designed to be serviced from the front.

VENTILATION

The Keating Gas Fryer must be installed in an area providing adequate air supply and ventilation. Do not obstruct the flow of combustion and ventilation air. Proper ventilation is one of the important considerations for efficient operation of the Keating Gas Fryer. It should be installed so that the products of combustion are removed efficiently without producing drafts that will interfere with proper burner operation. The intake for the exhaust fan should not be placed close to the flue of the Keating Gas Fryer to insure proper air flow necessary for combustion. The area around the front and bottom of the Keating Gas Fryer must be kept clear and unobstructed. In the USA, the ventilation systems must conform to the ANSI/NFPA96 latest edition. "A minimum of 18" (457mm) should be maintained between the flue outlet and the lower edge of the grease filters." Must be installed at least 16" away from any open flame. It is the responsibility of the owner and the local installer to comply with national and local codes.

NATIONAL CODE REQUIREMENT

The installation must conform with local codes, or in the absence of local codes, with the National Fuel Gas code, ANSI Z223.1 or the Natural gas Installation Code, CAN/CGA-B149.1 or the Propane Installation Code, CAN/CGA-B149.2. Flexible connectors must comply to ANSI Z221.69/CAN/CGA1.16. Keating equipment is designed and manufactured to operate only on the type of gas specified by the user and indicated on the serial plate located inside the door. The gas may be natural, propane or manufactured. The type of gas cannot be converted to another gas fuel by turning or engaging a switch.

LEVELING

The fryer will operate at its highest efficiency when properly leveled. Place a level on fryer vessel from side to side. For fryers on legs, the bottom foot of the leg is adjustable. Turn counter clockwise to decrease height or clockwise to increase height until level. For fryers on casters, the casters are adjustable by loosening the jam nut and turning the caster in or out. When the desired level is reached, tighten the jam nut. Adjustments of more than 3/4" are not recommended on any caster. The same procedure should be followed to level the fryer from front to back.

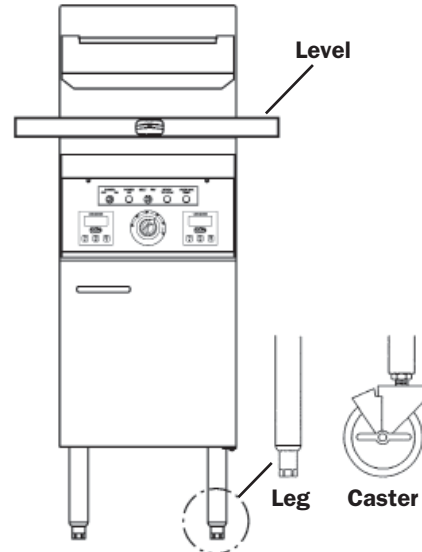

RESTRAINING DEVICES

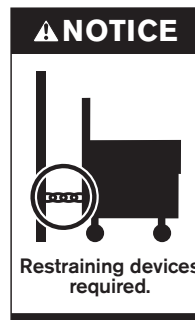

1. Adequate means must be provided to limit the movement of the appliance without depending on the connector and the quick-disconnect device or its associated piping to limit the appliance movement.

Fryer must also be restrained to prevent tipping when installed so that hot liquid splashing is avoided.

2. The restraint means must be attached to the rear of the Keating Gas Fryer within 2" of the center line width and approximately 1-5/8" from the bottom of the cabinet back to allow the restraining bolt to be anchored to the cabinet back between the cabinet bottom and inner liner.

NOTE: The installer is responsible for attaching the tipping restraint. See page 2 for drop-in installation.

If disconnection of the restraint is necessary, it must be reconnected when the Keating Gas Fryer is returned to its originally installed position.

NOTICE: WHEN THIS APPLIANCE IS INSTALLED WITH CASTERS, IT MUST BE INSTALLED WITH CASTERS SUPPLIED, A CONNECTOR COMPLYING WITH EITHER ANSI Z21.69 OR CAN/CGA-6.16 AND A QUICK-DISCONNECT DEVICE COMPLYING WITH EITHER ANSI Z21.41 OR CSA-6.9. IT MUST ALSO BE INSTALLED WITH RESTRAINING MEANS TO GUARD AGAINST TRANSMISSION OF STRAIN TO THE CONNECTOR, AS SPECIFIED IN THE APPLIANCE MANUFACTURER'S INSTRUCTIONS.

ELECTRICAL CONNECTION

The Keating fryer, when installed, must be electrically grounded in accordance with local codes, or in the absence of local codes, the National Electrical Code, ANSI/NFPA No. 70. or the Canadian Electrical Code, CSAC-22.2 as applicable. A wiring diagram is located on the last page. In the USA and Canada, the electrical supply must be 120 VAC, 60 Hz.

The Keating Instant Recovery® Gas Fryer is equipped with a 9' neoprene covered, 3 wire electrical cord with a three-pronged grounded plug for protection against electrical shock.

NOTE: The electrical wiring diagram for the fryer is located on the inside of the fryer door or in the back of this manual.

⚠ WARNING

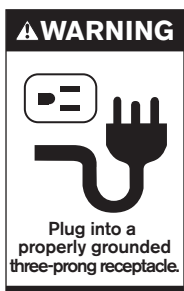

THIS APPLIANCE IS EQUIPPED WITH A THREE-PRONG 120 VOLT NEMA 5-15 (GROUNDING) PLUG FOR YOUR PROTECTION AGAINST SHOCK HAZARD AND SHOULD BE PLUGGED DIRECTLY INTO A PROPERLY GROUNDED AND POLARIZED THREE-PRONG RECEPTACLE. DO NOT CUT OR REMOVE THE GROUNDING PRONG FROM THIS PLUG.

⚠ CAUTION

Before plugging in the fryer, confirm the outlet is properly polarized and grounded. If the hot and neutral terminals are reversed or the outlet is not properly grounded, the burners may not ignite.

GAS CONNECTIONS AND PIPE SIZE

A single Keating Gas Fryer requires a standard gas pipe size of 3/4 inch (19mm) I.D. connection. Multiple fryers with a common manifold will require a minimum of 1 1/4 inch I.D. gas supply line. The size of the gas supply pipe is very important. If the pipe is too small you will have low gas pressure at the Keating Gas Fryer manifold. Low gas pressure will cause slow recovery and/or delayed ignition, amongst other problems. If you have a question about gas pipe size, call your local gas company.

⚠ CAUTION

Before connecting new pipe to the Keating Gas Fryer the pipe must be blown out to remove all foreign particles. These particles in the controls or burners may cause improper or dangerous operating conditions.

⚠ CAUTION

Pipe joint compounds that are used on threaded joints of appliance piping shall be resistant to the action of liquefied petroleum gases (Loctite PST 56765). When using pipe joint compound do not apply to the first two threads. Use only a very small amount and only on male threads. This will prevent clogging of burner orifices and the gas valve. Never use compound on female threads as it might be pushed into the gas valve.

Have your installer check for gas leaks using a soap and water solution before operating.

If more than one gas unit is on the same supply line, you may require a larger line. Consult your local gas company to assure adequate volume and pressure. Refer to serial plate for proper gas requirement for your particular model.

FLEXIBLE GAS CONNECTORS AND QUICK DISCONNECT DEVICES

For an appliance equipped with casters:

The installation shall be made with a connector that complies with the Standard for Connectors for Movable Gas Appliances, ANSI Z21.69 or the Standard for Connectors for Moveable Gas Appliances, CAN/CGA-6.16, and a quick disconnect device that complies with the Standard for Quick-Disconnect Devices for Use With Gas Fuel, ANSI Z21.41 or the Standard for Quick Disconnect Devices for Use with Gas Fuel, CAN1-6.9.

⚠ WARNING

NEVER LEAVE YOUR FRYER OPERATING UNATTENDED.

(When all previous instructions have been completed).

Check the serial plate on the panel (inside cabinet) to determine if the burner is set up for the proper type gas before connecting the quick-disconnect or piping from the building gas supply pipe.

a. **MINIMUM INCOMING** gas pressure

NATURAL GAS – 7 inches W.C. with burners on
LP GAS – 11 inches W.C. with burners on
ABSOLUTE MAXIMUM 13.8" W.C. (NG or LP)

b. Fryer **MANIFOLD** gas pressure

NATURAL GAS – 4 inches W.C. with burners on
LP – 10 inches W.C. with burners on

NOTE: It is estimated that half of all service calls made on Keating Instant Recovery® Fryers result from an inadequate gas supply. During installation, have a gas company representative make certain that the fryer is receiving adequate gas pressure and volume (see “Installation” or your serial plate on the fryer door).

⚠ WARNING

ALWAYS disconnect fuel source and power supply before servicing.

NEVER move a fryer when full of oil.

NEVER introduce objects or liquids into fryer, while operational, which are not designed or made for cooking.

THIS FRYER MAY NOT BE ALTERED, MODIFIED OR CHANGED IN ANY WAY.

⚠ WARNING



DO NOT USE AN OPEN FLAME TO CHECK FOR GAS LEAKS

1. The Keating Gas Fryer must be disconnected from the gas supply piping system during any pressure testing of that system at test pressures in excess of 1/2 psi (3.45kPa) (13.84 in WC). High pressure can damage the gas valve causing a hazardous condition. Excessive pressure introduced

to the fryer may void the warranty.

NOTE: Line pressure must be kept below 10" (Nat), 13" (LP) during leak test to avoid damage to the gas valve.

⚠ WARNING

PROPANE GAS MAY EVENTUALLY LOSE ITS ODOR AND PRECAUTIONS SHOULD BE TAKEN TO ASSURE THAT IT IS NOT PRESENT EVEN THOUGH YOU DO NOT DETECT AN ODOR. IF THERE IS ANY DOUBT, YOU SHOULD CALL YOUR LOCAL PROPANE GAS SUPPLIER FOR ASSISTANCE.

■ OPERATING

FILLING

NOTE: Before filling the fryer make certain the fryer vessel is sanitized, dry and the drain valve is completely closed.

⚠ WARNING

BE SURE THE HEAT TRANSFER TUBES ARE COMPLETELY COVERED WITH OIL BEFORE SWITCHING THE FRYER ON. IF OIL LEVEL DROPS BELOW TOP OF HEAT TRANSFER TUBES, SEVERE DAMAGE TO FRYER AND INJURY TO OPERATOR MAY RESULT.

⚠ WARNING

WATER IN ANY FORM AND HOT OIL DON'T MIX!

⚠ CAUTION

OIL EXPANDS WHEN HEATED. THE MAX LEVEL LINE HAS BEEN PROVIDED TO ENSURE OPTIMUM COOKING WHILE ENSURING THE SAFETY OF THE OPERATOR. DO NOT OVERFILL THE FRYER VESSEL.

Figure 1
MAX Level Line

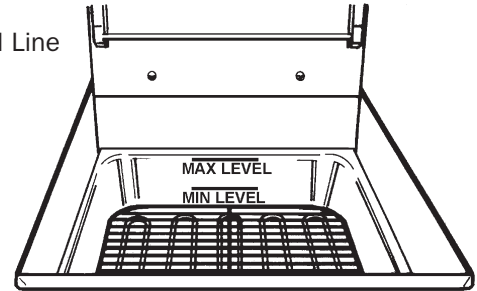

Fill the fryer vessel with oil or solid shortening up to the “Max” line.

LIGHTING

⚠ WARNING

BEFORE ATTEMPTING TO LIGHT THE FRYER, MAKE SURE THE GAS CONNECTIONS ARE SECURE AND HAVE BEEN LEAK TESTED AND THE FRYER HAS BEEN PROPERLY FILLED WITH OIL.

(See lighting instructions plate attached to the inner door of Keating Gas Fryer.)

Make sure that the Keating Gas Fryer is plugged in. If not your fryer will not operate. Make sure that the main gas valve on the gas supply line to the Keating Gas Fryer is in the “ON” position.

AIR IN THE GAS SUPPLY LINE MAY REQUIRE A LONGER THAN NORMAL PERIOD OF TIME TO LIGHT YOUR FRYER DURING INITIAL INSTALLATION OR AFTER OVERNIGHT SHUTDOWN.

NOTE: Your fryer cannot be operated during a power failure.

SERIES 2014 BB SPARK IGNITION OPERATING INSTRUCTIONS

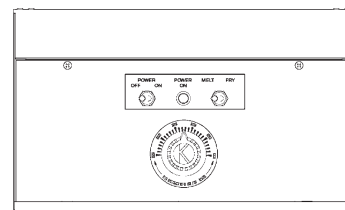

BB SPARK IGNITION CONTROL PANEL
SERIES 2014

⚠️ WARNING

DO NOT START FRYER WITHOUT FIRST FILLING FRY POT.

START-UP PROCEDURE

1. Set thermostat to the “OFF” position.
2. Turn “MAIN POWER” switch to the “ON” position. Its green light and timers will come on. The pilot runner tube will light on 2014 spark ignition units.
3. Set thermostat to desired temperature.
4. Set “MELT-IDLE-FRY” switch to “FRY” with oil in the fry pot. The burners will come on. Select “MELT” with solid shortening until liquid shortening is 1” from full, then switch to the “FRY” position after packing shortening around burner tubes.

SHUTDOWN PROCEDURE

1. Set thermostat to the “OFF” position.
2. Turn “MAIN POWER” switch to the “OFF” position.
3. Check to make sure all burners and pilot are extinguished.

SERIES 2014 TS SPARK IGNITION OPERATING INSTRUCTIONS

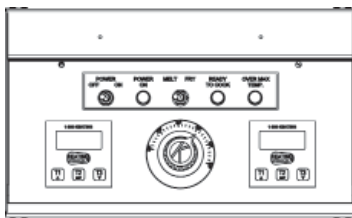

**TS SPARK IGNITION CONTROL PANEL
SERIES 2014**

⚠️ WARNING

DO NOT START FRYER WITHOUT FIRST FILLING FRY POT.

START-UP PROCEDURE

1. Set thermostat to the “OFF” position.
2. Turn “MAIN POWER” switch to the “ON” position. Its green light and the timers will come on. The pilot runner tube will light on 2014 spark ignition units.
3. Set thermostat to desired temperature.
4. Set “MELT-IDLE-FRY” switch to “FRY” with oil in the fry pot. The burners will come on. Select “MELT” with solid shortening until liquid shortening is 1” from full mark, then switch to the “FRY” position after packing shortening around burner tubes.

SHUTDOWN PROCEDURE

1. Set thermostat to the “OFF” position.
2. Turn “MAIN POWER” switch to the “OFF” position. Its green light will go off.
3. Check to make sure all burners and pilot are extinguished.

COOKING

Keating Instant Recovery® Gas Fryers are designed to provide maximum production efficiency and deliver high quality food products.

Low-temperature cooking, highly polished stainless steel and a true COLD ZONE mean extended oil life. Follow the cooking procedures for your model.



⚠️ WARNING

• OPERATION OF THIS FRYER SHOULD BE LIMITED TO PERSONNEL WHO HAVE BEEN THOROUGHLY TRAINED IN OPERATING PROCEDURES.

• CARE SHOULD BE TAKEN WHEN LOWERING BASKETS INTO FRYER TO PREVENT SPLASHING HOT OIL FROM FRYER VESSEL.

If your fryer has timers, push the “T1,” “T2” or “T3” button on the digital timer(s). For fryers with automatic basket lift, basket(s) will lower into fryer vessel.

When timer(s) sounds, carefully lift basket(s) out of hot oil. For fryers with automatic basket lift, a buzzer will sound and the basket(s) will rise automatically. Allow oil to drain before removing.

• NEVER LIFT BASKETS DIRECTLY OUT OF THE FRYER VESSEL WITHOUT DRAINING, AS SEVERE INJURY MAY RESULT.

• USE ONLY KEATING APPROVED BASKETS IN YOUR FRYER. NEVER OVERFILL FRY BASKETS. DO NOT BANG BASKETS ON BASKET HANGERS OR ON FRYER VESSEL.

Place basket(s) on basket hanger rods on splashback of fryer and allow to drain.

SHUTDOWN INSTRUCTIONS

Always turn the fryer off each night. See Shutdown procedure.

TS MODEL TIMER OPERATING INSTRUCTIONS PART # 056921

DIGITAL TIMERS

The electronic timers, standard on TS models, provide a clearly visible and accurate display and are very easy to use. Three different, independent cook times can be set using this timer - T1, T2, and T3.

PROGRAMMING

To program the timers, the unit must be in the idle mode. Press and hold the set button for approximately two seconds. The display will show "SEt". Press T1, T2, or T3 for the cook time to be programmed. The display will show the current setting for that cook time. Use the up or down button to increment or decrement the setting. When the setting is correct, press and hold the set button again for approximately two seconds. The display will show "StO" for approximately two seconds and the timer will return to normal operation. Repeat the process as necessary for the other timers.

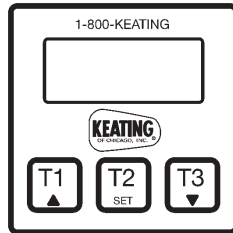

OPERATING LOGIC

When the timer is powered up, the display will show the time setting for the cook time that was operated last and the relay output contacts will be open. To start a cycle, press the desired cook time button (T1, T2 or T3). The display will begin to countdown from the preset time setting and the relay output contacts will close. During the countdown the colon will flash at a one-second rate. When the countdown has reached "00:00" the relay output contacts will open, the display will flash, and the audible alarm will sound. To cancel the audible alarm, press any button.

PAUSE FEATURE

To pause a cycle in progress, press any button. The relay output contacts will open, the display will flash, and the countdown will pause. To resume the countdown, press any button. The display will resume the normal countdown and the relay output contacts will close.

CANCELING A CYCLE

To cancel a cycle in progress press and hold any button for approximately two seconds. The relay output contacts will open and the display will show the time setting for the channel last used.

OIL BREAKDOWN

As part of a "Preventive Maintenance Program", the oil in your fryer needs to be filtered regularly. The initial investment in the frying system is far less than the total overall costs of oil during the life of the fryer, and with regular filtering, you can realize substantial savings in oil costs, as well as maintenance charges. We have listed some of the conditions which are catalysts in the breakdown of oil:

1. Contact with Oxygen
2. Carbonization of Crumbs and Food Particles
3. Non-Stainless Steel Surfaces
4. Keep Salt and Seasonings Away From Oil
5. Prolonged High Temperatures

DRAINING

⚠ WARNING

ALWAYS SHUT THE FRYER OFF COMPLETELY BEFORE DRAINING. THE FRYER SHOULD BE DRAINED ONLY UNDER THE SUPERVISION OF PROPERLY TRAINED PERSONNEL. A DRAIN PIPE AND COVERED CONTAINER SUITABLE FOR USE WITH HOT OIL SHOULD BE USED TO ENSURE THE SAFETY OF THE OPERATOR.

1. Operator should be outfitted with proper attire including:
 - Oil and heat resistant gloves
 - Oil and heat resistant apron
 - Safety goggles
 - Oil and heat resistant footwear

Figure 2

Operator in Safety Gear



2. Turn off the fryer and open the door.
3. Put suitable container under drain valve.
4. Drain oil from fryer by slowly turning handle. The drain will be completely open after 1/4 turn.
5. After fryer drains, close the drain valve.

6. Filtering may be done at this step.

Note: Fryers with a Safe & Easy® filter will drain differently. (See page 9)

⚠ CAUTION

UNDER NO CIRCUMSTANCES SHOULD YOU PERMIT HOT OIL TO COME IN CONTACT WITH WATER OR ICE. ALL DRAINING SHOULD BE DONE UNDER THE SUPERVISION OF PROPERLY TRAINED PERSONNEL.

A DRAIN PIPE AND COVERED CONTAINER SUITABLE FOR USE WITH HOT OIL SHOULD BE USED WHENEVER A FRYER IS DRAINED. ALWAYS DRAIN OIL INTO A COVERED RECEPTACLE.

CLEANING AND BOIL-OUT

FOR A SINGLE FRYER

When cleaning and boiling out your fryer use Keating Sea Powder and Keating Klenzer to keep your fryer in top condition.

Figure 3

Keating Klenzer and Sea Powder



1. Operator should be outfitted with proper attire including:
 - Oil and heat resistant gloves
 - Oil and heat resistant apron
 - Safety goggles
 - Oil and heat resistant footwear
2. Turn the fryer off. Remove baskets and screen.
3. Drain oil from fryer, see Draining.
4. Remove oil container to a secure area to prevent accidental spillage.
5. Close the drain valve.
6. Fill fryer vessel to “Max” line with water.
7. Set thermostat and turn fryer on to bring water to a gentle boil. Once boil has been reached, turn fryer off.

⚠ CAUTION

UNDER NO CIRCUMSTANCES SHOULD THE FRYER BE LEFT UNATTENDED DURING BOIL-OUT. TRAINED PERSONNEL MUST BE PRESENT DURING THE PROCEDURE TO PREVENT BOIL OVER OR TO TURN OFF THE POWER IF WATER DROPS BELOW HEAT TRANSFER TUBES.

8. Dissolve 2/3 cup of Keating Sea Powder for every five gallons of water and let soak for 1/2 hour. If there is a large build-up of carbonized grease, allow for fryer to soak overnight.

9. While soaking, a natural fiber brush may be used to scrub the tubes and inside walls of fryer. Drain the water and Sea Powder into a dry suitable receptacle and remove from cooking area. Sprinkle Keating Klenzer liberally on tubes and sides of fryer vessel. A non-abrasive scouring pad may be used to remove the now softened carbonized grease. Thoroughly rinse fryer vessel with potable water to remove all Klenzer. Prior to refilling with oil, wipe the inside of the fryer vessel making sure all water and Klenzer have been removed.

NOTE: Do not pump water through the filter system.

DO NOT DAMAGE OR REPOSITION THERMOSTAT PROBE AS THIS MAY AFFECT THE ACCURACY OF THE FRYER.

⚠ WARNING

WATER IN ANY FORM AND HOT OIL DON'T MIX!

10. Close the drain.
11. Check thermostat bulb positioning.
12. Refill the fryer with new or filtered oil.

⚠ CAUTION

To avoid damaging the fryer, do not power wash, spray or hose it down while cleaning it.

CLEANING AND BOIL-OUT FOR A FRYER WITH BUILT IN FILTER SYSTEM

When cleaning and boiling out your fryer use Keating Sea Powder and Keating Klenzer to keep your fryer in top condition.

DO NOT PUMP WATER THROUGH YOUR FILTER SYSTEM.

REFER TO YOUR FILTER MANUAL FOR INSTRUCTIONS ON PROPER USE.

SAFE & EASY® FILTER (SIDE VIEW)

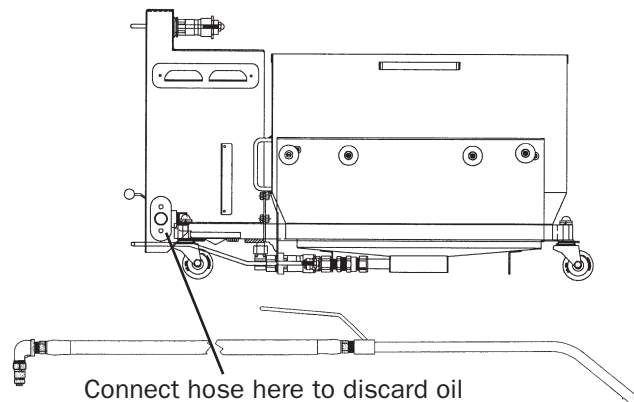

⚠ CAUTION

A KEATING FRYER OR FILTER SHOULD BE DRAINED ONLY UNDER THE SUPERVISION OF PROPERLY TRAINED PERSONNEL. WHEN DISCARDING OIL, A COVERED RECEPTACLE APPROVED FOR USE WITH HOT OIL SHOULD BE USED. USE OF A NON-APPROVED RECEPTACLE OR METHOD OF DRAINING THE OIL COULD JEOPARDIZE THE SAFETY OF THE OPERATOR.

⚠ WARNING

1. Operator should be outfitted with proper attire including:
 - Oil and heat resistant gloves
 - Oil and heat resistant apron
 - Safety goggles
 - Oil and heat resistant footwear

2. Turn the fryer off.

A cleaning hose and wand have been provided for discarding oil.

3. Attach cleaning hose to quick disconnect located on the bottom right side of your filter.
4. Remove baskets and screen. Drain fryer into the central filter drawer.
5. Open the discard valve located near the quick disconnect in the filter cabinet.
6. The hose may now be used to pump the oil into the shortening handling system and discarded properly.
7. Remove oil container to a secure area to prevent accidental spillage.
8. Close the drain valve.
9. Fill fryer vessel to “Fill Level” line with water.
10. Set thermostat and turn fryer on to bring water to a gentle boil. Once boil has been reached, turn fryer off.

⚠ CAUTION

UNDER NO CIRCUMSTANCES SHOULD THE FRYER AND FILTER BE LEFT UNATTENDED DURING BOIL-OUT. TRAINED PERSONNEL MUST BE PRESENT DURING THE PROCEDURE TO PREVENT BOIL OVER OR TO TURN OFF THE POWER IF WATER DROPS BELOW HEATING TRANSFER TUBES.

11. Dissolve 2/3 cup of Keating Sea Powder for every five gallons of water and let soak for 1/2 hour. If there is a large build-up of carbonized grease, allow fryer to soak overnight.
12. While soaking, a natural fiber brush may be used to scrub the tubes and inside walls of fryer. Pump the water and Sea Powder into a dry suitable receptacle and remove from cooking area. Sprinkle

Keating Klenzer liberally on tubes and sides of fryer vessel. A non-abrasive scouring pad may be used to remove the now softened carbonized grease. Thoroughly rinse fryer vessel with potable water to remove all Klenzer. Prior to refilling with oil, wipe the inside of the fryer vessel making sure all water and Klenzer have been removed.

DO NOT DAMAGE OR REPOSITION THERMOSTAT PROBE AS THIS MAY AFFECT THE ACCURACY OF THE FRYER.

⚠ WARNING

WATER IN ANY FORM AND HOT OIL DON'T MIX!

13. Close the drain valve and disconnect the cleaning hose from filter machine. Quick disconnect will remain hot for approximately 15 minutes.
14. Check thermostat bulb positioning (should be 1 paper thickness away from heat tube).
15. Refill the fryer with new or filtered oil. Wait until filter drawer is cool before cleaning, approximately 15 minutes.
16. Remove filter drawer, drain, clean and dry.
17. Prepare filter drawer and return to filter cabinet.

⚠ CAUTION

To avoid damaging the fryer, do not power wash, spray or hose it down while cleaning it.

18. Pump must be primed with oil after boil-out with water.

FAILURE TO LUBRICATE PUMP MAY CAUSE SEVERE DAMAGE TO FILTER SYSTEM.

SELF HELP GUIDE

Before calling for service, review this list. It may save you both time and expense. This list includes common occurrences that are not the result of defective workmanship or materials in this appliance.

PROBLEM	SOLUTION
Fryer does not operate	<ul style="list-style-type: none"> • Check power cord, unit plugged in? • Thermostat is in the OFF position. • Check gas supply. • Reset high limit.

NOTE: For a fryer with a Central or Safe & Easy® Filter always check the rear drain operating handle before attempting to use the fryer. A safety switch prevents the fryer from operating if the handle is not pushed in completely and latched. (See figure 4)

Figure 4

Rear Drain Operating Handle

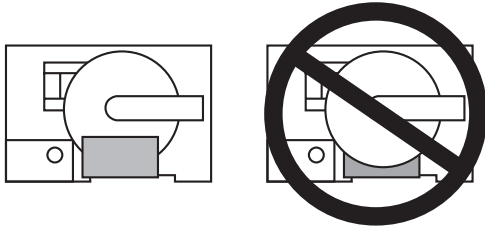

PREVENTIVE MAINTENANCE

Preventive maintenance should be done in daily, weekly, monthly and yearly intervals as necessary. Following preventive maintenance procedures will help keep your fryer working efficiently. Proper care and servicing will lead to years of quality performance.

PREVENTATIVE MAINTENANCE CHART

TIME FRAME	OPERATOR/OWNER
AT LEAST DAILY*	<ul style="list-style-type: none"> • Check lights and controls. • Check that the oil is up to “Max” line. • Clean all baskets. • Drain, strain or filter oil.
AT LEAST WEEKLY*	<ul style="list-style-type: none"> • Drain and clean fryer. • Boil-out fryer.
AT LEAST BI-MONTHLY*	<ul style="list-style-type: none"> • Hi-Limit & Test procedures.
AT LEAST MONTHLY*	<ul style="list-style-type: none"> • Check calibration of Thermostat.
TIME FRAME	QUALIFIED SERVICE PERSONNEL
AT LEAST YEARLY*	<ul style="list-style-type: none"> • Check burner flame color and adjust air shutters. • Disassemble fryer to clean pilot and burner orifices and runner pilot tube. • Clean Pilot Runner Tube. • Check and replace wing turbulators.

*High production facilities should be checked more often. Contact the factory or a local service company to perform maintenance and repairs.

HI-LIMIT CHECK BI-MONTHLY

Place an accurate thermometer in the oil. If the Hi-Limit Control doesn't shut off the fryer between 425°F and 450°F, have it replaced.

THERMOSTAT - LIMITED CALIBRATION

(Less than 25° difference between dial plate setpoint and actual oil temperature)

You will need:

- One screwdriver with 1/8" wide flat blade
- One accurate fryer thermometer

Figure 5

Thermostat knob removed to reveal calibration screws

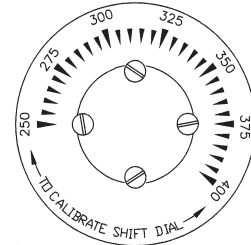

1. Set thermostat to desired frying temperature.
2. Allow fryer to cycle three times.
3. Place an accurate thermometer in the oil.
NOTE: Locate thermometer in same position for every calibration. Left front corner of fryer vessel at the High Limit Bulb is recommended.
4. If temperature of fryer is found to be less than 25°F off, remove the thermostat knob. There are (4) screws holding the dial plate in place. Loosen the screws and reset the dial plate to match the thermometer reading.

⚠ WARNING

DO NOT ADJUST THE THERMOSTAT SET SCREW - IT VOIDS ANY WARRANTY ON PART.

THERMOSTAT BULB POSITIONING

BEFORE REPLACING, TEST THERMOSTATS

NOTE: Operational problems can easily be corrected by thermostat bulb positioning.

Keating's patented thermostat application is accurate within 2°F of the dial setting between 250°F – 350°F. This accuracy is attained only if the thermostat bulb is placed properly against the heat transfer tube. To quickly and accurately test for proper bulb placement, a single thickness of writing paper should be pulled through between the tube and the bulb with medium resistance.*

Thermostat Bulb Positioning 10x11, 18 & Up

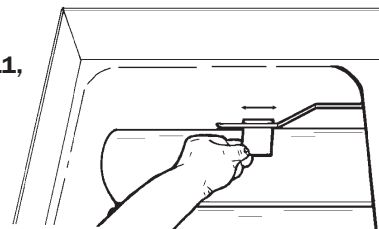

1. *For 14" Gas Fryers:

- The end of thermostat bulb should touch the burner tube.

2. For 10x11", 18" & Up Gas Fryers:

- If the bulb is too loose, the paper will slip through with little or no resistance. A fryer with a thermostat bulb that is too loose will overshoot.

Overshoot: The thermostat takes a long time to cycle and then misses its preset temperature by 20°F - 40°F yielding a poor quality product.

- If the bulb is too tight, the paper will either not pull through or it will tear. A fryer with a thermostat bulb that is too tight will short cycle.

Short Cycle: The thermostat will cycle rapidly while the fryer is in the idle mode; the temperature will be erratic.

REQUIRED TEST THERMOSTAT

Multimeter (for testing continuity)

CHECKING CONTINUITY WITH THE MULTIMETER

1. Rotate the thermostat shaft until an audible click is heard.
2. Rotate the thermostat shaft left and right ten times causing the switch to click on and off ten times, while using the Multimeter to verify continuity.
3. If the switch does not show continuity during all ten trials, replace the thermostat.

 WARNING

DISASSEMBLING THE THERMOSTAT WILL VOID THE THERMOSTAT WARRANTY.

1. Set compression ring onto capillary end of bulb finger tight, 1/2" from end of capillary.
2. Insert new thermostat bulb through control panel back.
3. Apply oil resistant flexible sealant onto compression fitting thread before installing fitting into fryer vessel.
4. Position bent portion of bulb against far right heat transfer tube and install compression fitting snugly into fryer vessel.
5. Adjust bulb so at least 2" of bent portion of it is next to heat transfer tube and tighten compression nut onto compression fitting for fryer 10x11, 18 & up. The end of thermostat bulb should touch the burner tube for 14" fryers.
6. Replace burners.
7. Replace control panel back.
8. Slide back fabric shield over capillary and carefully coil capillary. Avoid crimping.

9. Reconnect wires to thermostat body.
10. Replace two screws which hold thermostat body to control panel.
11. Replace control panel.
12. Replace three retaining screws and washers which hold dial plate in place.
13. Replace thermostat knob.
14. Connect electric power source. Turn on gas and pilots.
15. Boil out fryer.
16. Refill fryer with oil to "fill level line".
17. Start fryer, preheat and calibrate with thermometer.

WARRANTY REPAIRS

Keating's warranty begins with the date of installation. In the event that your Instant Recovery® Fryer, under warranty, needs repairs other than routine cleaning, you are requested to contact KEATING OF CHICAGO, INC. (1-800 KEATING).

■ SERVICE DIAGNOSIS

The following diagnosis is only to be used as a guide to qualified service personnel. Keating recommends that you use a qualified & licensed service company. (Equipment still under warranty requires it.) Call 1-800-KEATING if you need assistance in locating a qualified service company.

NOTE: To correctly and quickly diagnose the system, the chart below should be followed in sequential order.

TROUBLE SHOOTING CHART

PROBLEM	PROBABLE CAUSE	SOLUTION
Runner pilot tube won't light	<ul style="list-style-type: none"> a. Gas isn't turned on. b. No electricity to fryer. c. Hi-Limit has been activated. d. Clogged runner pilot orifice(s). e. Drain valve isn't pushed in completely (fryers with built-in filter system). 	<ul style="list-style-type: none"> a. Turn manual gas valve on. If using flexible connector with quick disconnect, make sure quick disconnect is completely engaged. b. Plug fryer into approved outlet, reset circuit breaker; if tripped, diagnose circuit to determine cause of tripping. c. Push Hi-Limit reset button located under control panel. d. Turn fryer and manual gas valve off. Clean orifice(s) and other parts as necessary. e. Push in and latch drain valve handle to activate rear drain safety switch. Turn off fryer & turn back on.
Runner pilot won't stay lit	<ul style="list-style-type: none"> a. Low gas supply or pressure. b. Dirty runner pilot tube or pilot orifice(s). c. Low pilot flame height. d. Hi-Limit has been activated. e. Exhaust problems or drafts in kitchen. f. Delayed ignition. g. Faulty remote flame sensor or circuit. 	<ul style="list-style-type: none"> a. Verify if size of incoming gas line to fryer and manifold gas pressure are adequate. b. Turn fryer and manual gas valve off. Clean orifice(s) and pilot tube. c. Adjust pilot flame height. d. Push Hi-Limit reset button located under control panel. e. Install or adjust flue restrictors. If problem persists, contact your HVAC representative. f. See diagnosis on page 13. g. Check sensor alignment on runner pilot tube. Check sensor and sensor GND wire connections on runner tube and in control panel back assembly, or in external module box assembly.
Burners will not light	<ul style="list-style-type: none"> a. Switch not set to fry. b. Thermostat is faulty. c. Fry/Off/Melt switch is faulty. d. Faulty gas valve. 	<ul style="list-style-type: none"> a. Set MELT/IDLE/FRY switch (or MELT/FRY switch) to FRY. Set thermostat to desired temperature. b. Diagnose thermostat using multimeter (Check to make sure thermostat contacts open and close properly around set point temperature). c. Replace switch. d. Replace gas valve.
Fryer overshoots temperature setting	<ul style="list-style-type: none"> a. Thermostat bulb improperly placed. b. Thermostat out of calibration. 	<ul style="list-style-type: none"> a. Adjust bulb position. See page 10, Thermostat Bulb Positioning. b. Calibrate thermostat. See page 10, Thermostat Calibration.

PROBLEM	PROBABLE CAUSE	SOLUTION
Delayed ignition	<ul style="list-style-type: none"> a. Dirty runner pilot tube or pilot orifice(s). b. Low pilot flame height. c. Exhaust problems or drafts in kitchen. d. Low gas supply or pressure. 	<ul style="list-style-type: none"> a. Turn fryer and manual gas valve off. Clean orifice(s) and pilot tube. b. Adjust pilot flame height. c. Install or adjust flue restrictors. If problem persists, contact your HVAC representative. d. Verify if size of incoming gas line to fryer and manifold gas pressure are adequate.
Oil in fryer vessel smokes	<ul style="list-style-type: none"> a. Oil has begun to breakdown. b. High carbon content in oil. c. Dirty fryer vessel. d. Inferior grade of oil. e. Fryer is overheating. f. Hi-Limit Control has failed. 	<ul style="list-style-type: none"> a. Replace oil. b. Filter oil completely, replace if necessary. c. Boil-out fryer. d. Check with supplier for the grade of oil needed for your cooking applications. e. Check calibration of thermostat (See page 10) and replace if necessary. f. Check if Hi-Limit trips at 425° F. If not, replace Hi-Limit.
Fryer vessel boiling over	<ul style="list-style-type: none"> a. Over-filling fryer with oil. b. Product overloaded in fryer vessel. c. Oil breakdown causing foaming. d. Water in the cold zone. 	<ul style="list-style-type: none"> a. Fill fryer up to "Max Level" line as oil will expand when heated. b. Follow recommended cooking production figures in determining proper size of loads c. Replace oil. d. Stir oil repeatedly with a paddle until water boils off. Filter oil. If necessary, allow oil to cool. Drain about one quart of it to remove remaining water.
Flames come out top of flue	<ul style="list-style-type: none"> a. Excessive gas supply or pressure. b. Collapsed burner turbulators. c. Exhaust problems. 	<ul style="list-style-type: none"> a. Adjust pressure, change burner orifices or install in-line regulator. b. Replace turbulators. c. Install or adjust flue restrictors. If problem persists, contact your HVAC representative.
Flames come out front of fryer	<ul style="list-style-type: none"> a. Exhaust problems. b. Turbulators have slipped forward. c. Flue blockage. 	<ul style="list-style-type: none"> a. Install deflector to block down draft. Install or adjust flue restrictors. If problem persists, contact your HVAC representative. b. Reposition turbulators. c. Turn fryer and manual gas valve off. Let flue cool and remove foreign objects.
Fryer has poor recovery or runs cold	<ul style="list-style-type: none"> a. Baskets overfilled. b. Fryer vessel overfilled with oil. c. Carbon coating on heat transfer tubes. d. Turbulators collapsed or out of position. e. Faulty or erratic thermostat. f. Low gas supply or pressure. g. Thermostat bulb improperly placed. 	<ul style="list-style-type: none"> a. Don't over fill baskets. b. Fill fryer up to "Fill Level" line or "Max Level" line as oil expands when heated. c. Boil-out fryer. See page 8, Cleaning and Boil-Out. d. Reposition or replace turbulators. e. Replace thermostat. f. Verify if size of incoming gas line to fryer and manifold gas pressure are adequate. g. Adjust bulb position. See page 10, Thermostat Bulb Positioning.

PROBLEM	PROBABLE CAUSE	SOLUTION
Basket-Lift mechanism will not operate	<ul style="list-style-type: none"> a. Connections are loose or timer faulty. b. Breaker has tripped. c. Basket-lift relay is faulty. d. Actuator is defective. 	<ul style="list-style-type: none"> a. Tighten connections. Replace timer if faulty. b. Reset breaker located on power box in rear of fryer. Circuit breakers on newer units can be found under the control panel. c. Replace relay. d. Replace actuator if 24VDC is present.
Fryer is making a lot of noise	<ul style="list-style-type: none"> a. Misadjusted air shutters on the burners. 	<ul style="list-style-type: none"> a. Loosen screw that holds the air shutter on the burner. Move air shutter so the screw is in the middle of the slot on the shutter. Make all the shutters the same.

■ ORDERING PARTS

Parts may be ordered by calling 1-800-KEATING or your local Keating service company. You may also order on-line at Keating's part store, www.keatingofchicago.com

Refer to the Keating Gas Fryer Limited Warranty for complete service and ordering information.

The model/serial plate is attached to the inside of the front door. The serial and model numbers are necessary when ordering.

NOTE: On Drop-In fryers, the model/serial plate is attached to the top of the control panel.

WARNING AND OPERATING PLATES

All warning and operating plates on the Instant Recovery® Gas Fryer should be in place at all times. If plates are damaged or lost, replace them immediately.

GAS FRYER PARTS LIST - MODELS WITH UNI-POT

(Part numbers correspond to pages 16-18)

ITEM	DESCRIPTION	MODEL	PART #	10x11	14	18	20	24	34x24
Quantity Per Model									
1	GAS VALVE, 24V 1/2" x 1/2"	BB, TS NATURAL	060187	1	1	1	1	1	
		LP	060187	1	1	1	1	1	
	3/4" x 3/4" - Series 2008	NATURAL	054324						1
		LP	054324						1
3	RUNNER PILOT TUBE	1-800-KEATING		1	1	1	1	1	1
6	RUNNER PILOT AIR SHUTTER	NIPPLE W/NUT	015747	1	1	2	2	2	3
		CLIP	004090	1	1	2	2	2	3
7	RUNNER PILOT ORIFICE	1-800-KEATING		1	1	2	2	2	3
8	RUNNER PILOT ORIFICE HOLDER	STRAIGHT	004142	1	1	2	2	2	3
9	CENTER PILOT ORIFICE HOLDER		017385						1
10	RUNNER PILOT 90° ELBOW	(1/4" - 1/8")	015746	1	1	2	2	2	2
		18 ONLY	021162			2			
11	RUNNER PILOT TEE	IN TUBING	006474			1	1	1	2
14	CORRUGATED 1/4" TUBING (Specify length)	1-800-KEATING							
15	TURBULATOR	BB, TS	060357	2	3	4	4	5	6
16	BURNER	BB, TS	028048	2	3	4	4	5	6
17	BURNER ORIFICE	1-800-KEATING		2	3	4	4	5	6
18	BURNER HOLD DOWN BAR	1-800-KEATING		1	1	1	1	1	2
19	BURNER SPACER	18 AND ABOVE	019683			4	4	5	6
20	FRYER VESSEL	1-800-KEATING		1	1	1	1	1	1
21	DRAIN VALVE, FRONT, 1"	BB, TS	016884	1	1				
	DRAIN VALVE, REAR, 1"	BB, TS	016341	1	1				
	DRAIN VALVE, FRONT, 1 1/4"	BB, TS	004554			1	1	1	1
	DRAIN VALVE, REAR, 1 1/4"	BB, TS	016342			1	1	1	2
	DRAIN VALVE, FRONT, 2"	BB, TS	021256				1	1	
	DRAIN VALVE, FRONT, 2"	BB, TS	019722			1			
22	DOOR CATCH, MAGNET	BB, TS	053386			1	1	1	2
23	HI-LIMIT CONTROL W/RESET	BB, TS	SEE PAGES 19-20						
24	THERMOSTAT	BB, TS	SEE PAGES 19-20						
25	BASKET HANGER	BB, TS	SEE BELOW						
27	DOOR HANDLE	BB, TS	004542	1	1	1	1	1	2
28	SPARK IGNITION ELECTRODE	BB, TS	030253	1	1	1	1	1	1
29	FLAME SENSE ELECTRODE	BB, TS	061240		1	1	1	1	1
30	HEATSHIELDS, BURNERS	BB, TS	059020	2	3	2	4	5	6
	HEATSHIELD, BURNER, RIGHT	BB, TS	059060			1			
	HEATSHIELD, BURNER, LEFT	BB, TS	059061			1			
31	EXTERNAL SPARK MODULE BOX ASSEMBLY	BB, TS	061446	1	1				
				(Front Drain Only*)					

ITEM	DESCRIPTION	MODEL	18	20	24
25	BASKET HANGER	BB, TS	018556	018559	018562

*See assembly diagram to replace spark module only.

GAS FRYER ASSEMBLY

(See Part Numbers on page 15)

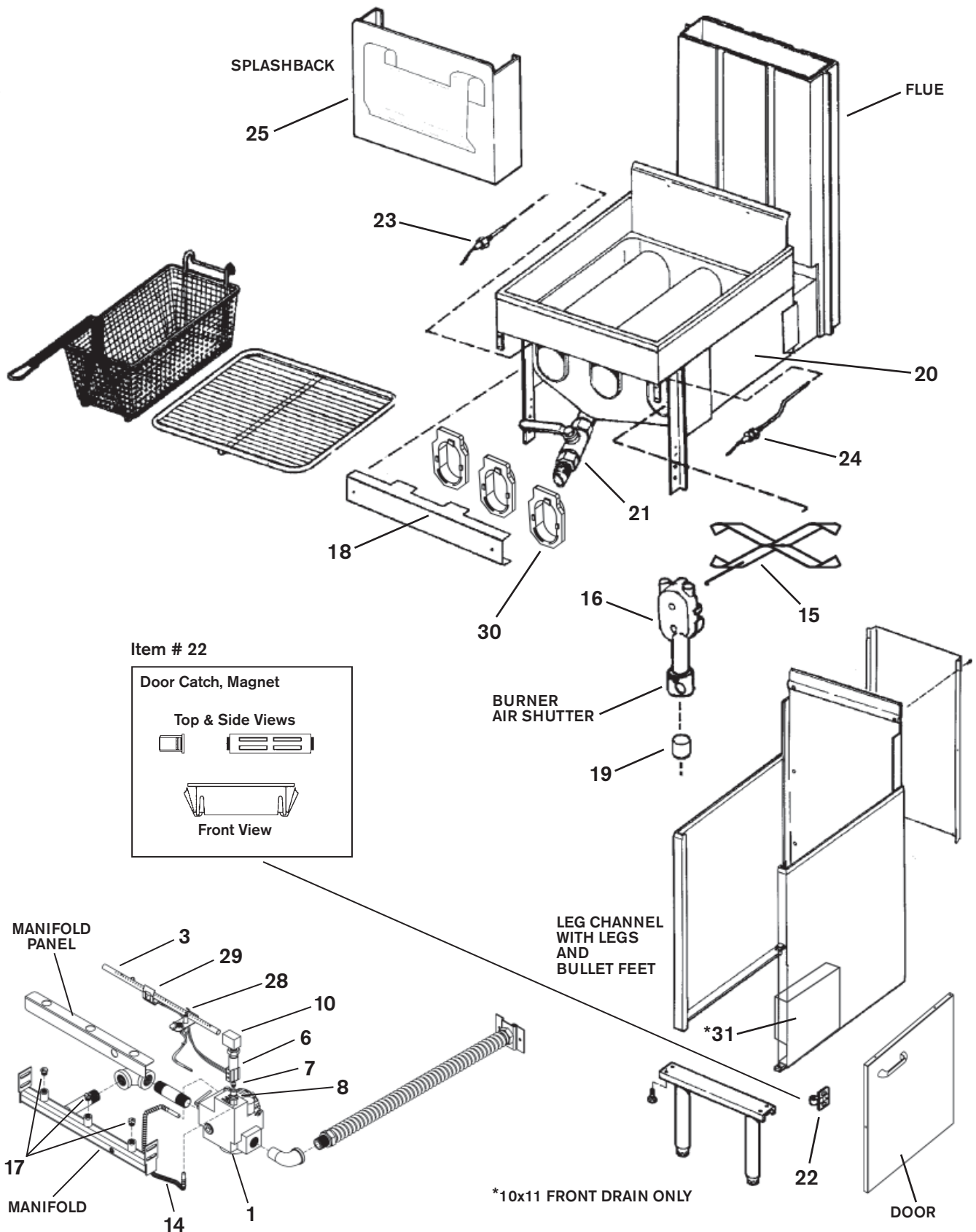

Item # 22

Door Catch, Magnet

Top & Side Views

Front View

*10x11 FRONT DRAIN ONLY

RUNNER PILOT TUBE ASSEMBLY - SERIES 2014

Spark Ignition Models

(See Part Numbers on page 15)

Models 10x11 BB, TS UNI-POT NO REMOTE SENSE

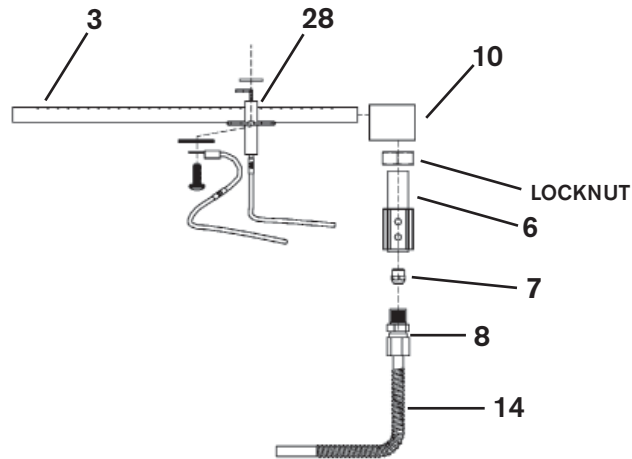

Models 14 BB, TS WITH REMOTE SENSE

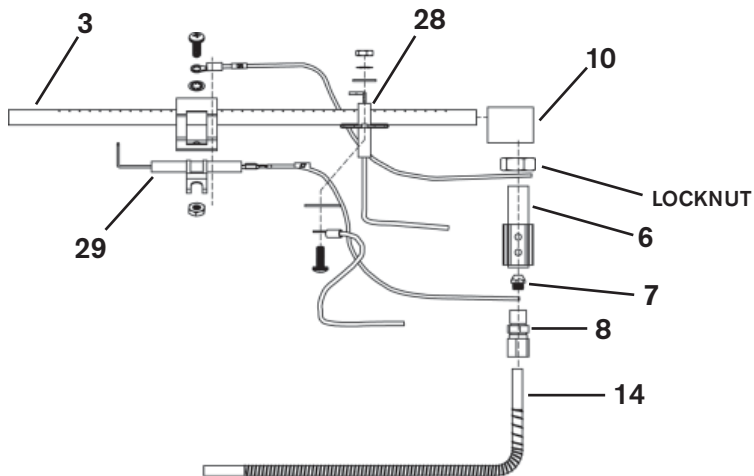

RUNNER PILOT TUBE ASSEMBLY - SERIES 2014

Spark Ignition Models

(See Part Numbers on page 15)

Models 18 BB, TS UNI-POT WITH REMOTE SENSE

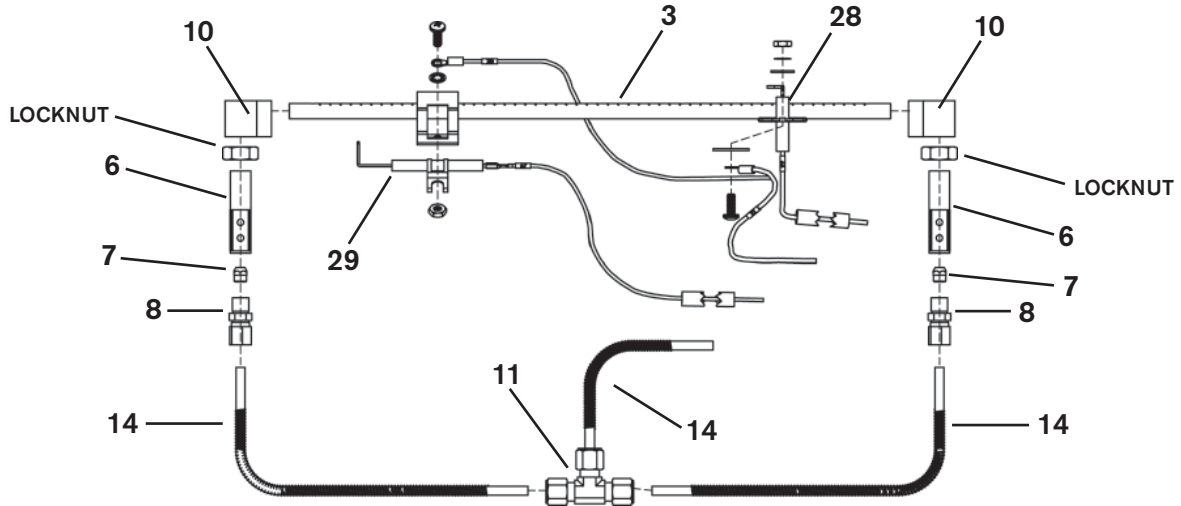

Models 20 BB, TS UNI-POT WITH REMOTE SENSE

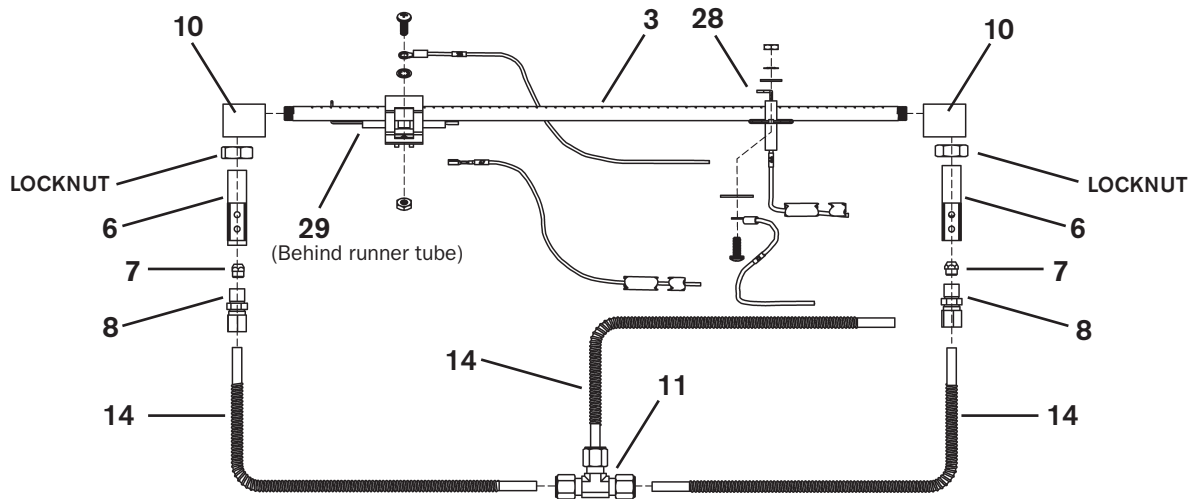

RUNNER PILOT ASSEMBLY - SERIES 2014

Spark Ignition Models

(See Part Numbers on page 15)

Models 24 BB, TS UNI-POT WITH REMOTE SENSE

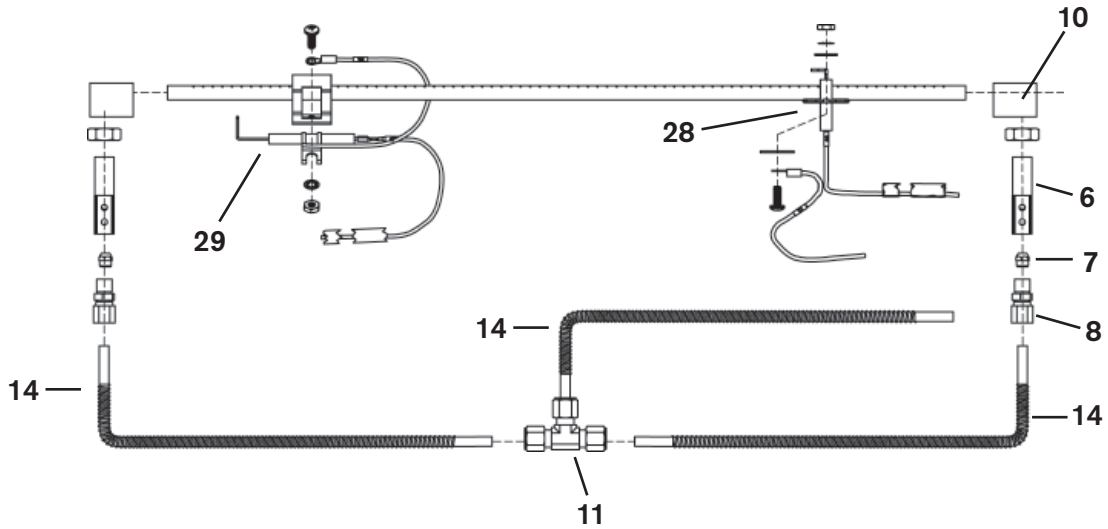

Model 34x24 BB, TS WITH REMOTE SENSE

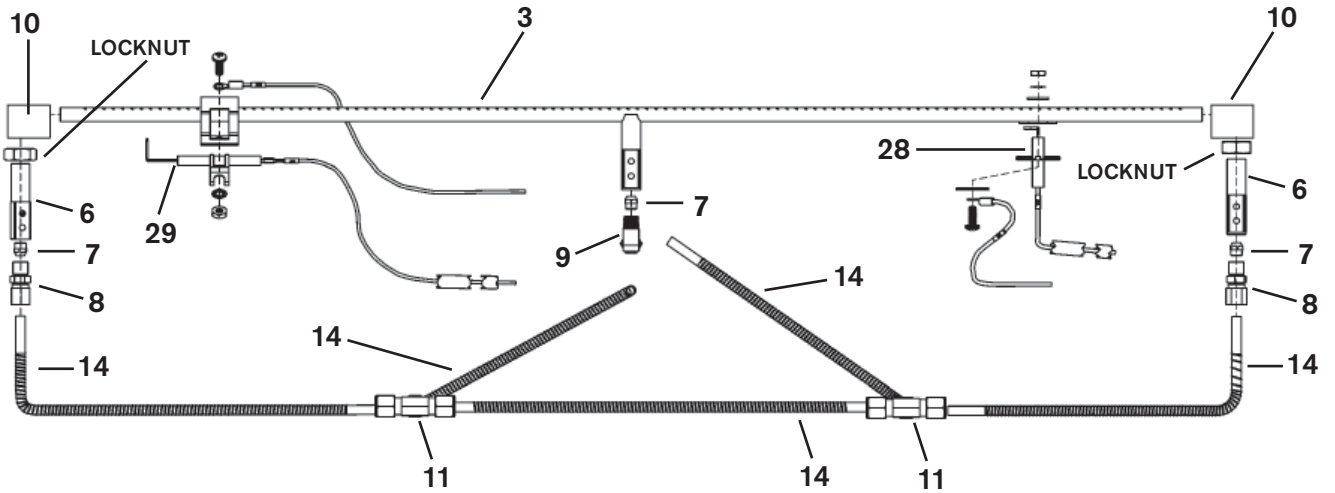

**CONTROL PANEL BB
SPARK IGNITION - SERIES 2014**

CONTROL PANEL FRONT

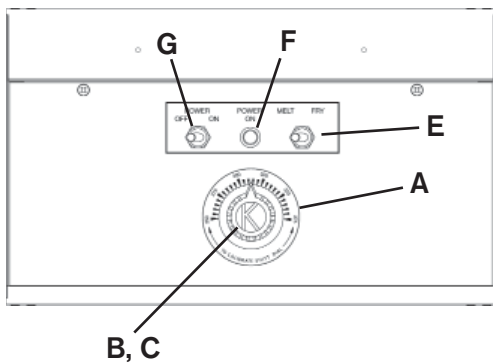

10x11 BB BACK PANEL - FRONT DRAIN UNIT

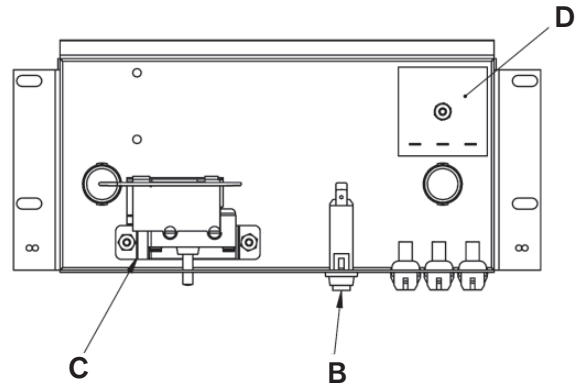

BACK PANEL - REAR DRAIN UNIT

NOTE: View may be different for different size fryers.

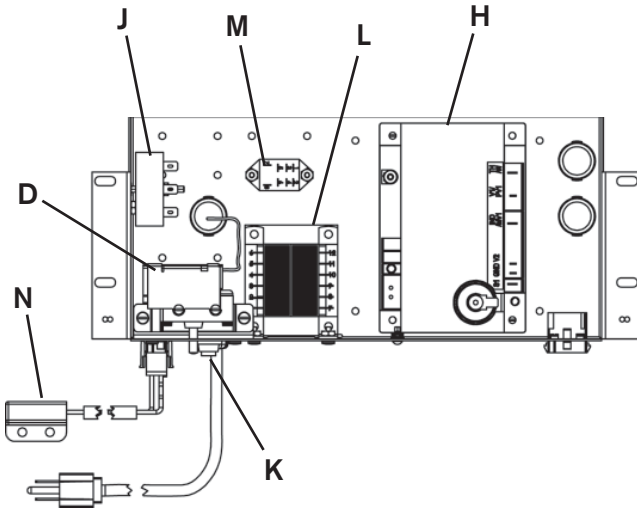

ITEM	QTY	DESCRIPTION	P/N
A	1	THERMOSTAT DIAL PLATE 250°- 375°F	058037
B	1	THERMOSTAT KNOB, BLACK	060612
C	1	GAS FRYER THERMOSTAT 14 BB, TS, CPU	035574
		10x11, 18" and Larger	035575
D		HIGH LIMIT (Resettable)	004341
E	1	SWITCH TOGGLE MELT-FRY	059143
F	1	INDICATING LIGHT CLEAR	057863
G	1	SWITCH TOGGLE POWER	059141
H	1	SPARK MODULE REMOTE SENSE	060682
J	1	FAT MELT INFINITE CONTROL	037470
K	1	CIRCUIT BREAKER 3AMP 1P	053338
L	1	TRANSFORMER 24VAC	024032
M	1	RELAY DPDT 24VAC	030844
N	1	MAGNETIC SAFETY SWITCH	053777

ITEM	QTY	DESCRIPTION	P/N
B	1	CIRCUIT BREAKER 3AMP 1P	053338
C	1	HIGH LIMIT (Resettable)	004341
D	1	FAT MELT INFINITE CONTROL	037470

BB BACK PANEL - FRONT DRAIN UNIT

NOTE: View may be different for different size fryers.

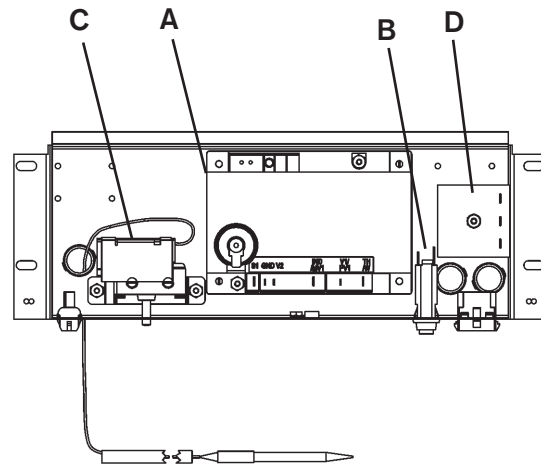

ITEM	QTY	DESCRIPTION	P/N
A	1	SPARK MODULE, REMOTE SENSE	060682
B	1	CIRCUIT BREAKER 3AMP 1P	053338
C	1	HIGH LIMIT (Resettable)	004341
D	1	FAT MELT INFINITE CONTROL	037470

**CONTROL PANEL TS
SPARK IGNITION - SERIES 2014**

CONTROL PANEL FRONT

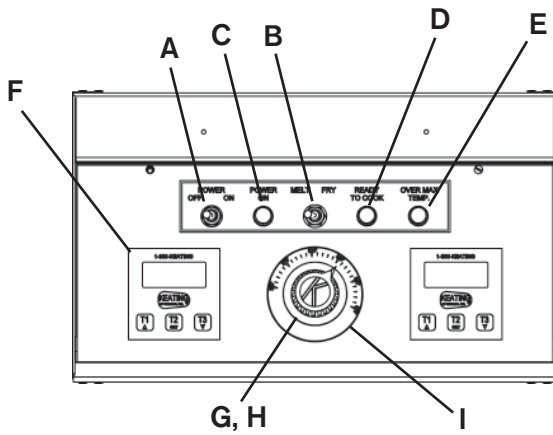

BACK PANEL - FRONT DRAIN UNIT

NOTE: View may be different for different size fryers.

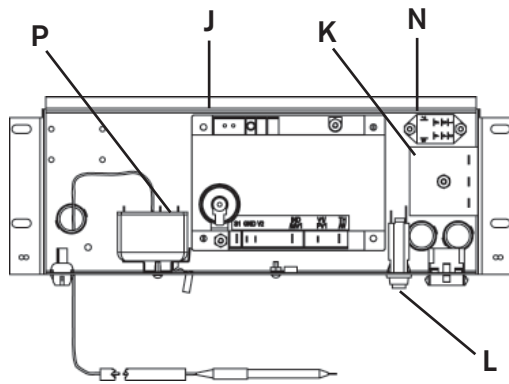

ITEM	QTY	DESCRIPTION	P/N
A	1	SWITCH TOGGLE POWER	059141
B	1	SWITCH TOGGLE MELT-FRY	059143
C	1	INDICATING LIGHT WHITE	038511
D	1	INDICATING LIGHT GREEN	038495
E	1	INDICATING LIGHT RED	061184
F	2	DIGITAL TIMER 24V	056921
G	1	THERMOSTAT KNOB, BLACK	060612
H	1	GAS FRYER THERMOSTAT	035575
I	1	THERMOSTAT DIAL PLATE 250°- 375°F	058037
J	1	SPARK MODULE REMOTE SENSE	060682
K	1	FAT MELT CONTROL	037470
L	1	CIRCUIT BREAKER 3AMP 1P	053338
N	1	RELAY DPDT 24VAC	030844
P	1	HIGH LIMIT (Resettable)	034357

10x11 TS BACK PANEL - FRONT DRAIN UNIT

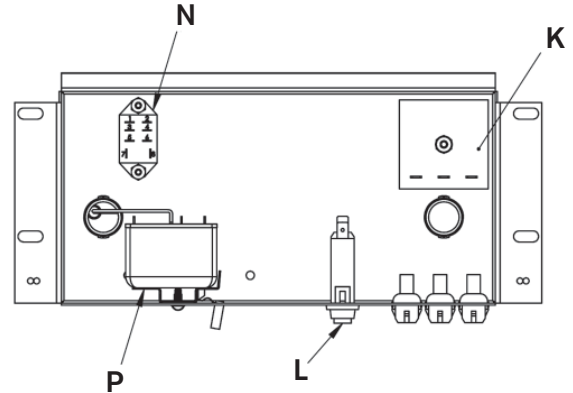

ITEM	QTY	DESCRIPTION	P/N
K	1	FAT MELT INFINITE CONTROL	037470
L	1	CIRCUIT BREAKER 3AMP 1P	053338
N	1	RELAY DPDT 24VAC	030844
P	1	HIGH LIMIT (Resettable)	034357

BACK PANEL - REAR DRAIN UNIT WITH
SAFE & EASY® FILTER

NOTE: View may be different for different size fryers.

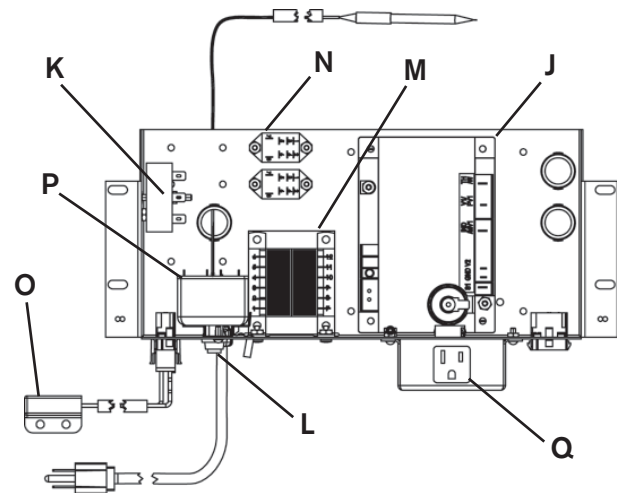

ITEM	QTY	DESCRIPTION	P/N
J	1	SPARK MODULE REMOTE SENSE	060682
K	1	FAT MELT CONTROL	037470
L	1	CIRCUIT BREAKER 3AMP 1P	053338
M	1	TRANSFORMER 24VAC	024032
N	2	RELAY DPDT 24VAC	030844
O	1	MAGNETIC SAFETY SWITCH NC	053777
P	1	HIGH LIMIT (Resettable)	034357
Q	1	RECEPTACLE 120V	011505

SPARK IGNITION DESIGN

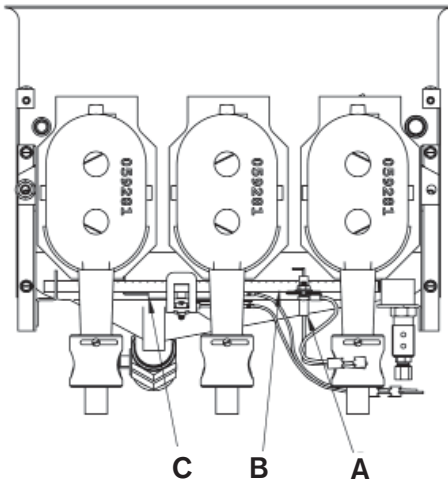

ITEM	QTY	DESCRIPTION	P/N
A	1	SPARK IGNITION ELECTRODE	030253
B	1	RUNNER PILOT TUBE	
		10x11"	021656
		14"	060686
		18"	060934
		20"	060973
		24"	061002
		34x24	060911
C	1	FLAME SENSE ELECTRODE	061240

ELECTRICAL BOX ASSEMBLY GAS FRYER SERIES 2000

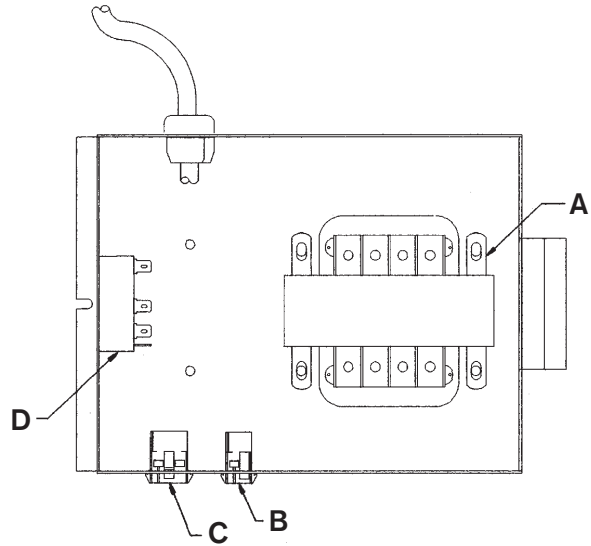

ITEM	DESCRIPTION	P/N	QTY
A	TRANSFORMER		
	120V/240V TO 24V	024032	1
B	2 PIN CONNECTOR	032207	1
C	9 PIN CONNECTOR	028303	1
D	FAT MELT 24V	037470	1

10x11 EXTERNAL SPARK MODULE BOX ASSEMBLY

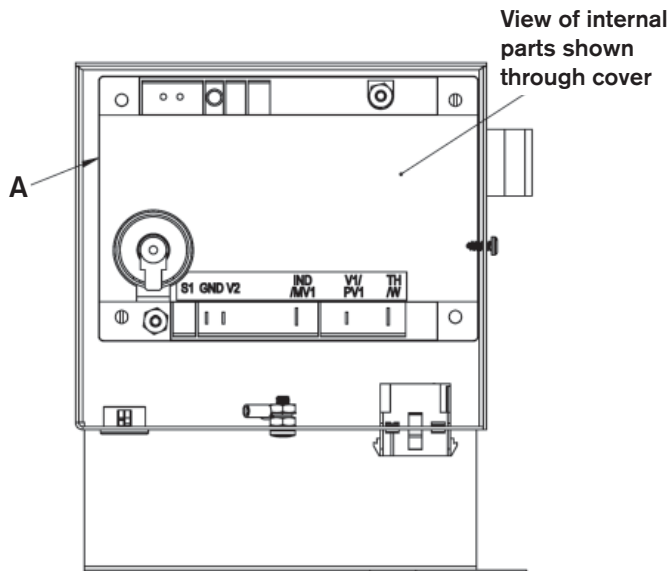

ITEM	QTY	DESCRIPTION	P/N
A	1	SPARK IGNITION MODULE (NO REMOTE SENSE)	059819

BASKET LIFT POWER SUPPLY BOX 2007

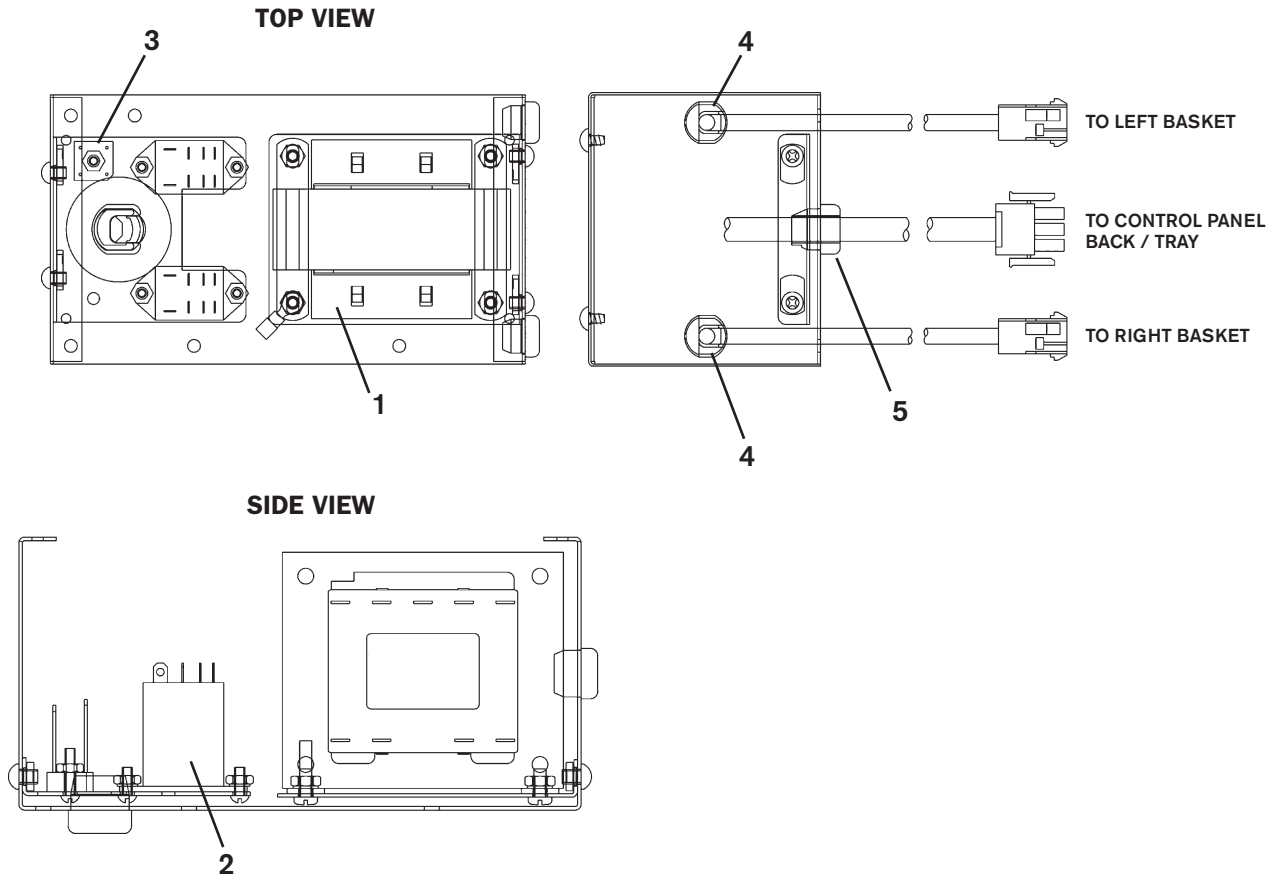

ITEM	DESCRIPTION	P/N	QTY
1	TRANSFORMER STEPDOWN 24VAC 100VA	058359	1
2	RELAY DPDT 24VAC	030844	2
3	RECTIFIER 24VDC	018321	1
4	BUSHING STRAIN RELIEF 5/8" HOLE	000470	2
5	BUSHING STRAIN RELIEF 3/4" HOLE	033800	1

NOTE: Circuit breaker is located under the control panel.

BASKET LIFT ASSEMBLY

(not shown to scale)

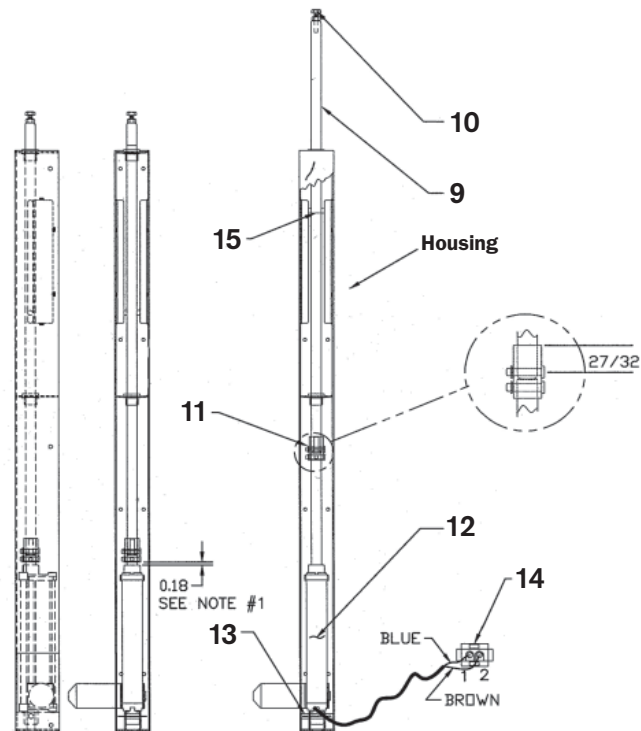

- NOTES:**
1. A minimum distance of 3/16" and maximum distance of 1/4" should be maintained when actuator is at full downward stroke. Item 11 should never be bottomed on item 12 when in this location.
 2. Actuator shaft should travel 6 1/2" upward from lowest position.
 3. Distance is to be measured when actuator is powered.
 4. Apply light coating of food grade grease to Item 9 on entire shaft inside housing.

ITEM	DESCRIPTION	P/N	QTY
9	PUSH ROD	018096	1
10	SCREW 1/4"-20" x 1 1/4"	021091	1
	HEX NUT 1/4-20	016383	1
11	COUPLER ACTUATOR BL	054525	1
	RETAINING RING	054540	2
	PIN COUPLER ACTUATOR BL	054503	2
12	ACTUATOR 24V DC	054510	1
13	SHAFT ACTUATOR LOWER BL S/S	054522	1
14	CONNECTOR 2 CIRCUIT PLUG	032208	1
	CONNECTOR CONTACT PIN MALE	028309	2
15	PIN BASKET LIFT NON ROTATIONAL	054760	1

■ WIRING DIAGRAMS

(SEE INSIDE FRYER DOOR FOR CURRENT WIRING DIAGRAMS)

10x11 BB 2014 SPARK IGNITION ELECTRICAL ASSEMBLY - FRONT DRAIN

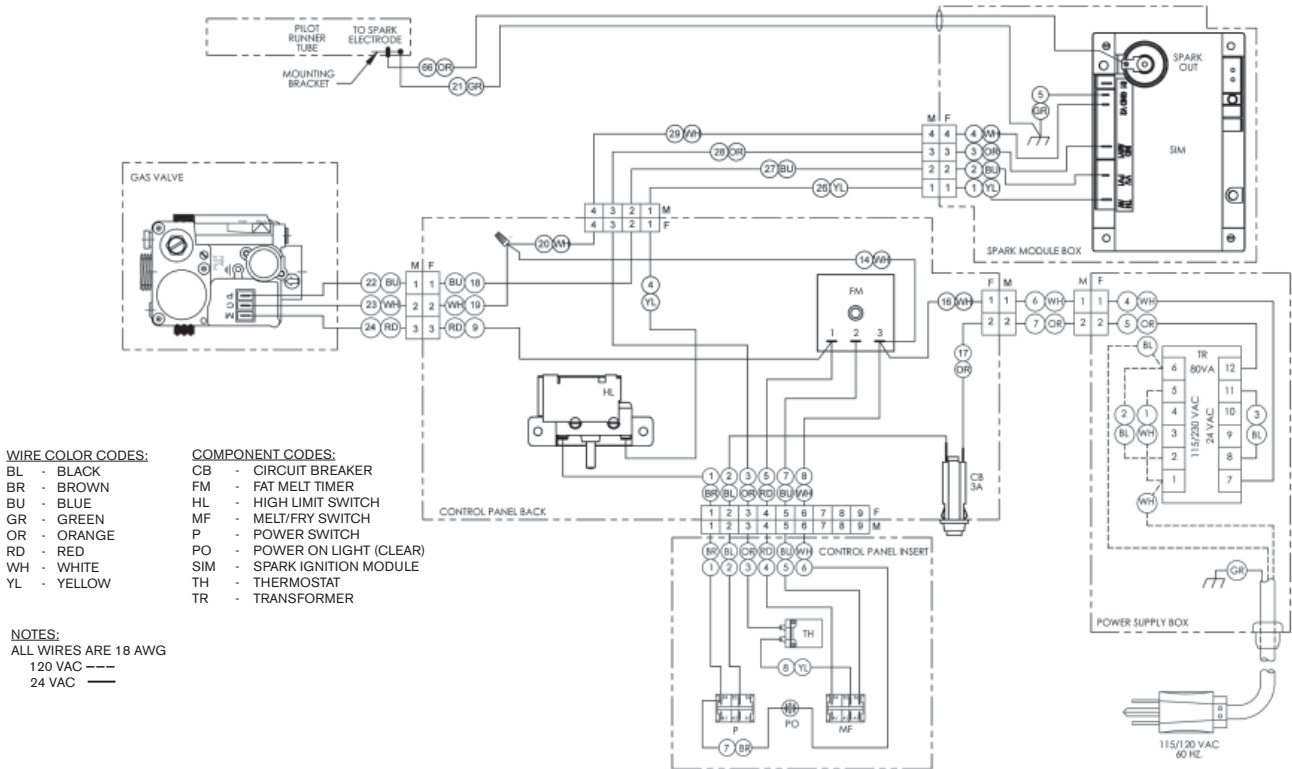

10x11 TS 2014 SPARK IGNITION ELECTRICAL ASSEMBLY - FRONT DRAIN

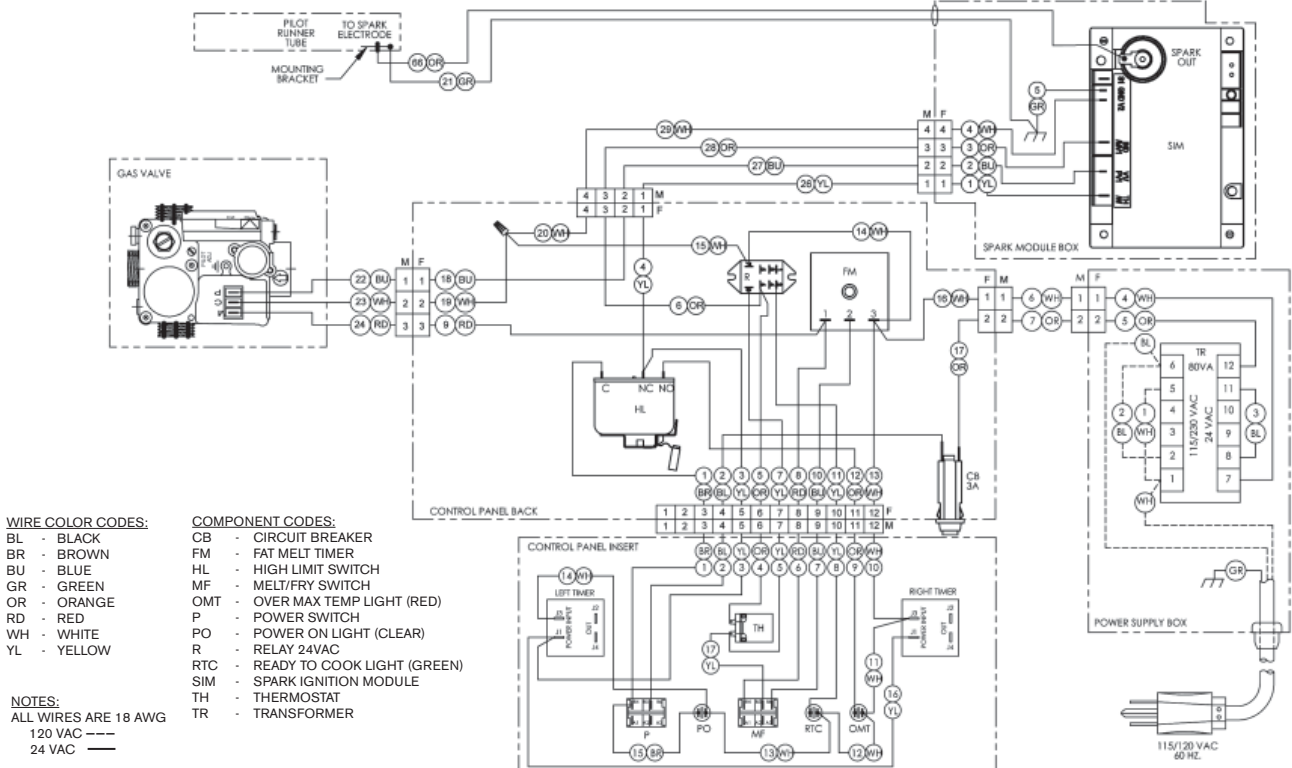

BB 2014 SPARK IGNITION ELECTRICAL ASSEMBLY - FRONT DRAIN

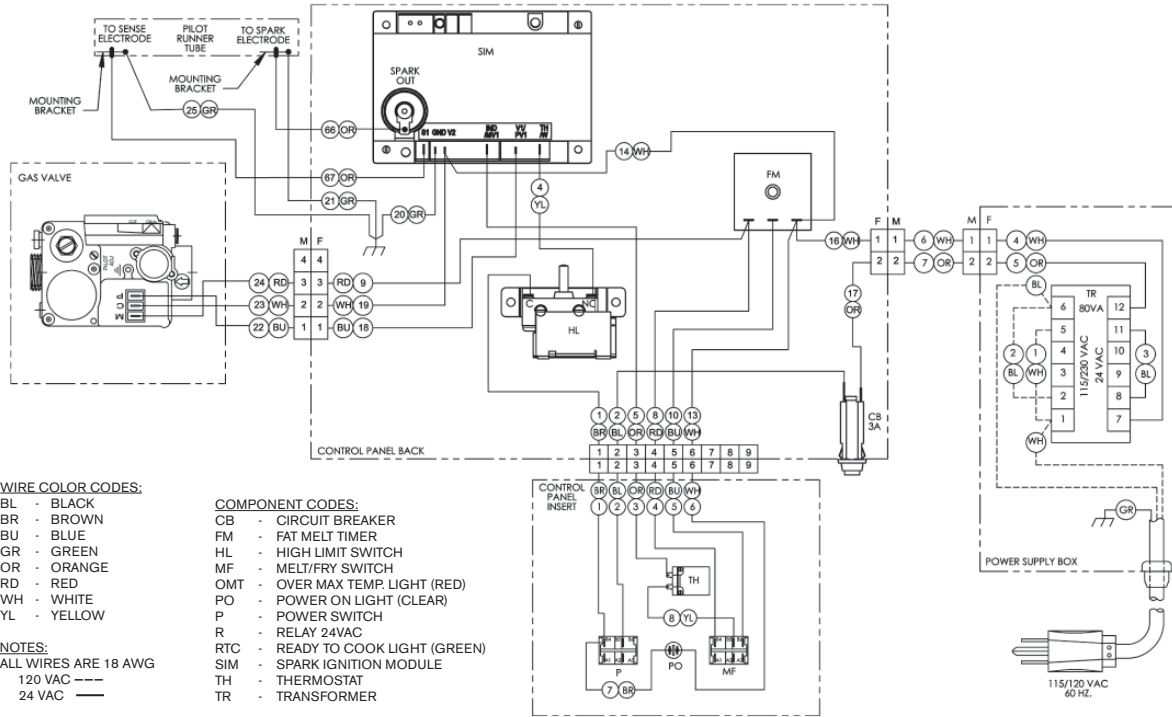

BB 2014 SPARK IGNITION ELECTRICAL ASSEMBLY - REAR DRAIN WITH SAFE & EASY® FILTER

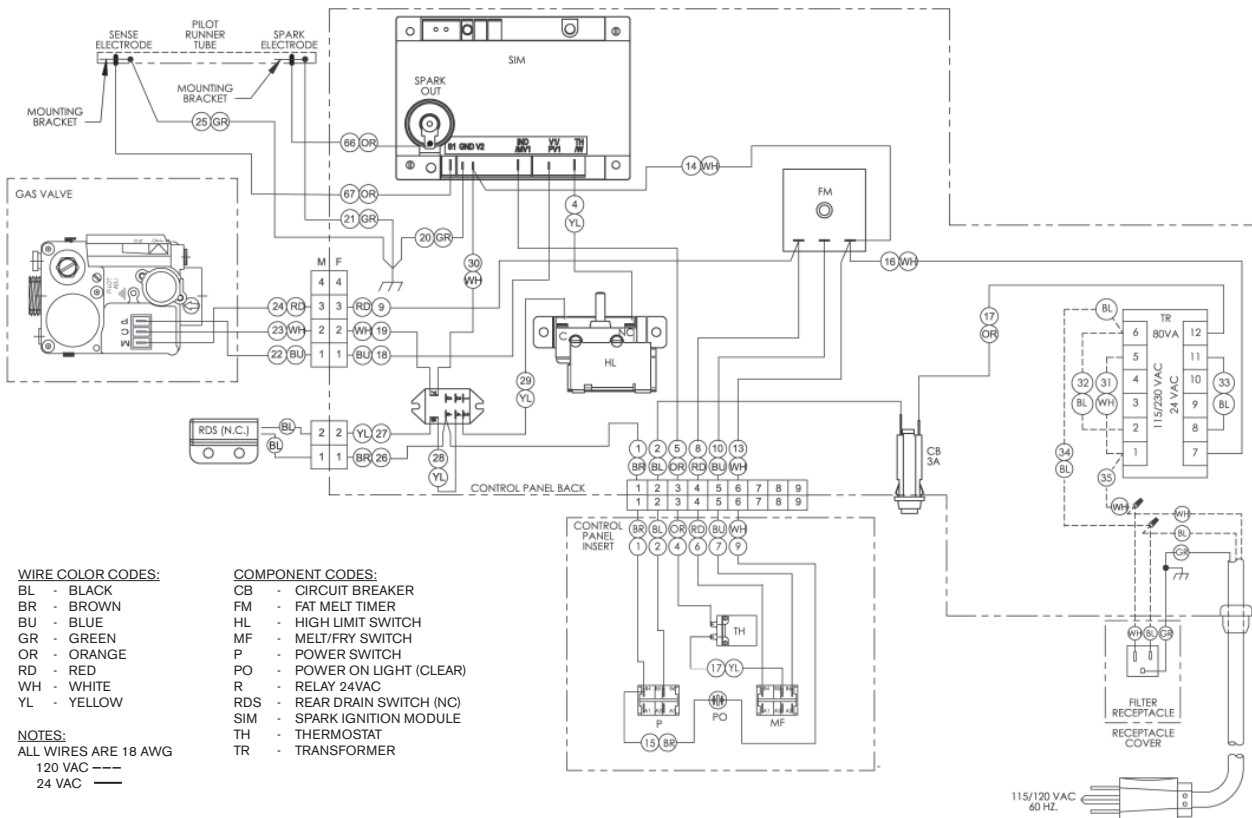

TS 2014 SPARK IGNITION ELECTRICAL ASSEMBLY - FRONT DRAIN

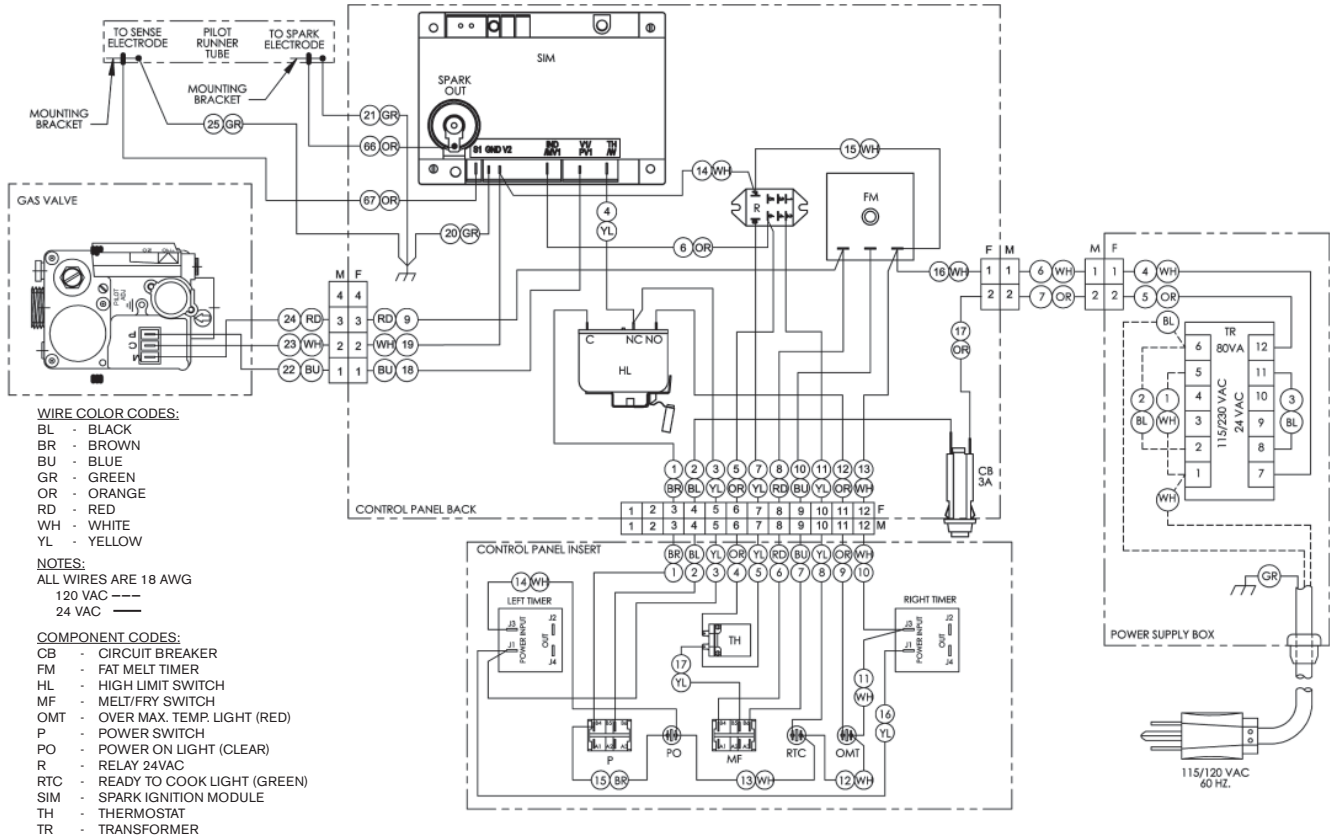

TS 2014 SPARK IGNITION ELECTRICAL ASSEMBLY - REAR DRAIN WITH SAFE & EASY® FILTER

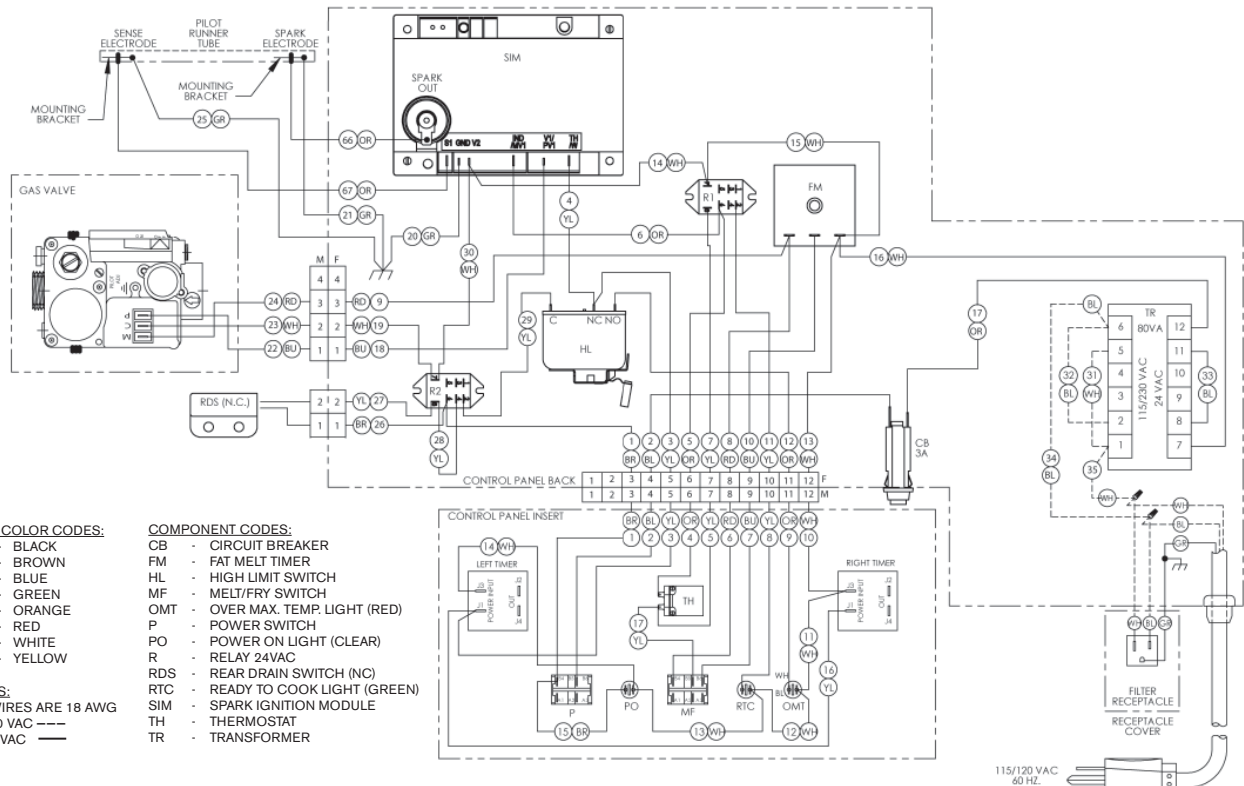

TS 2014 SPARK IGNITION ELECTRICAL ASSEMBLY - REAR DRAIN WITH BASKET LIFT

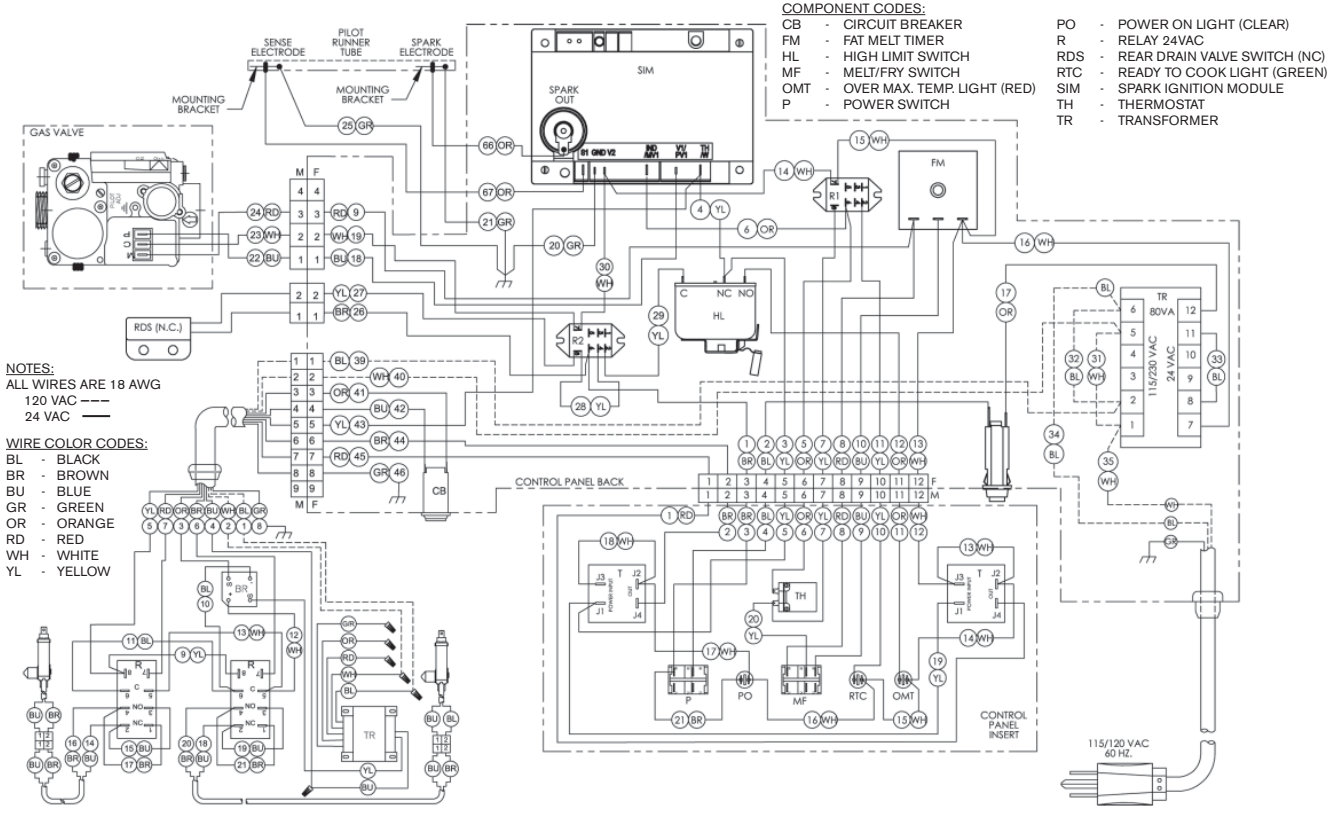

TS 2014 SPARK IGNITION ELECTRICAL ASSEMBLY - REAR DRAIN WITH BASKET LIFT WITH SAFE & EASY® FILTER

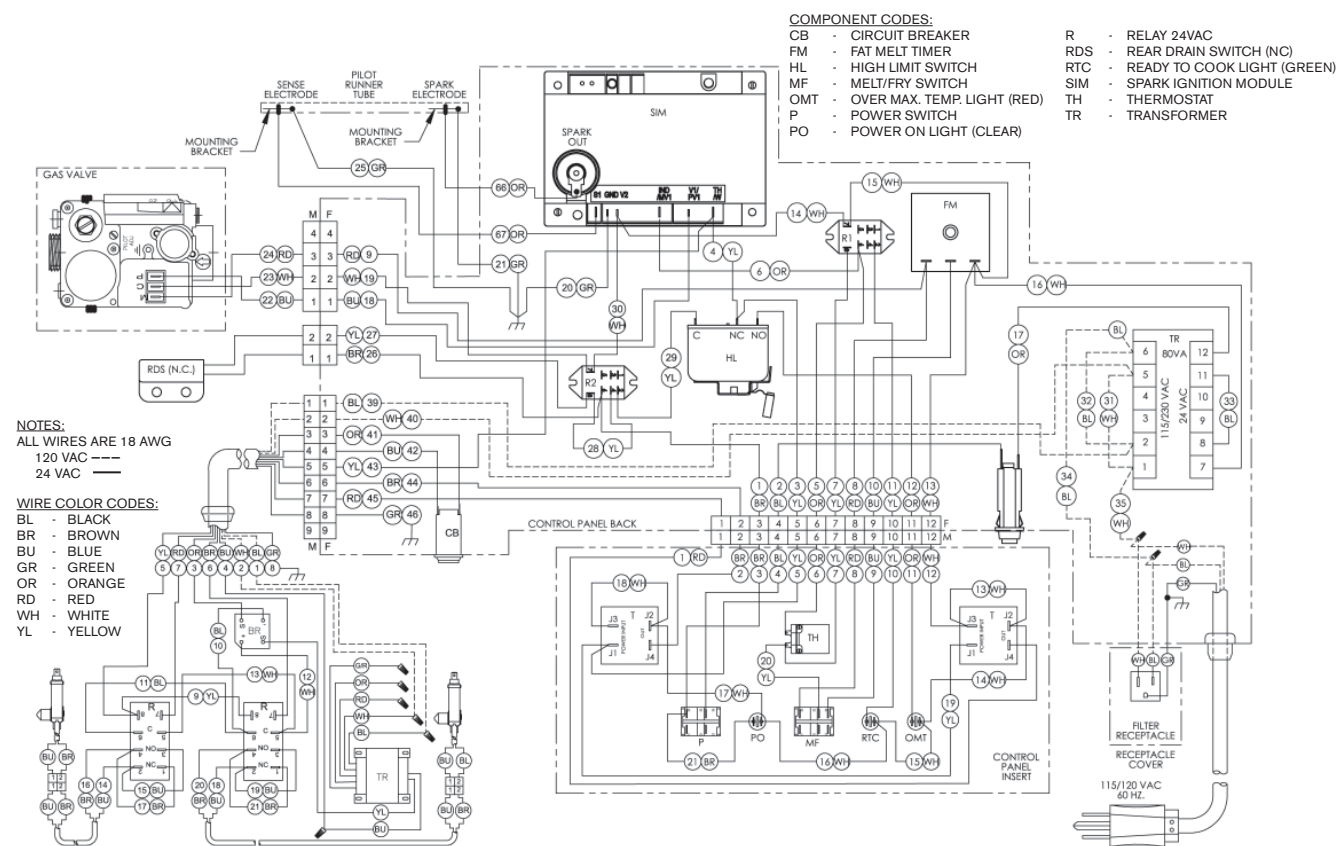

34x24 BB 2014 SPARK IGNITION ELECTRICAL ASSEMBLY - FRONT DRAIN

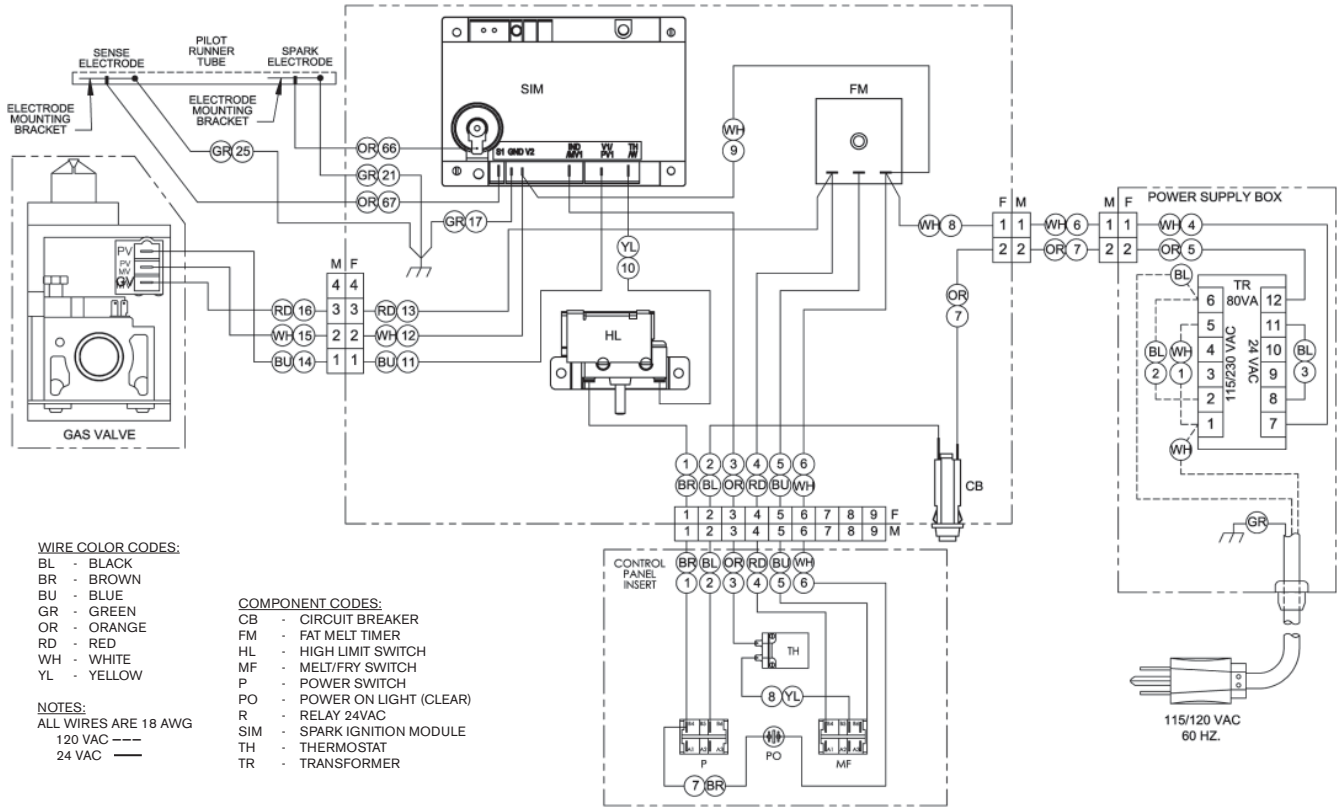

34x24 BB 2014 SPARK IGNITION ELECTRICAL ASSEMBLY - REAR DRAIN WITH SAFE & EASY® FILTER

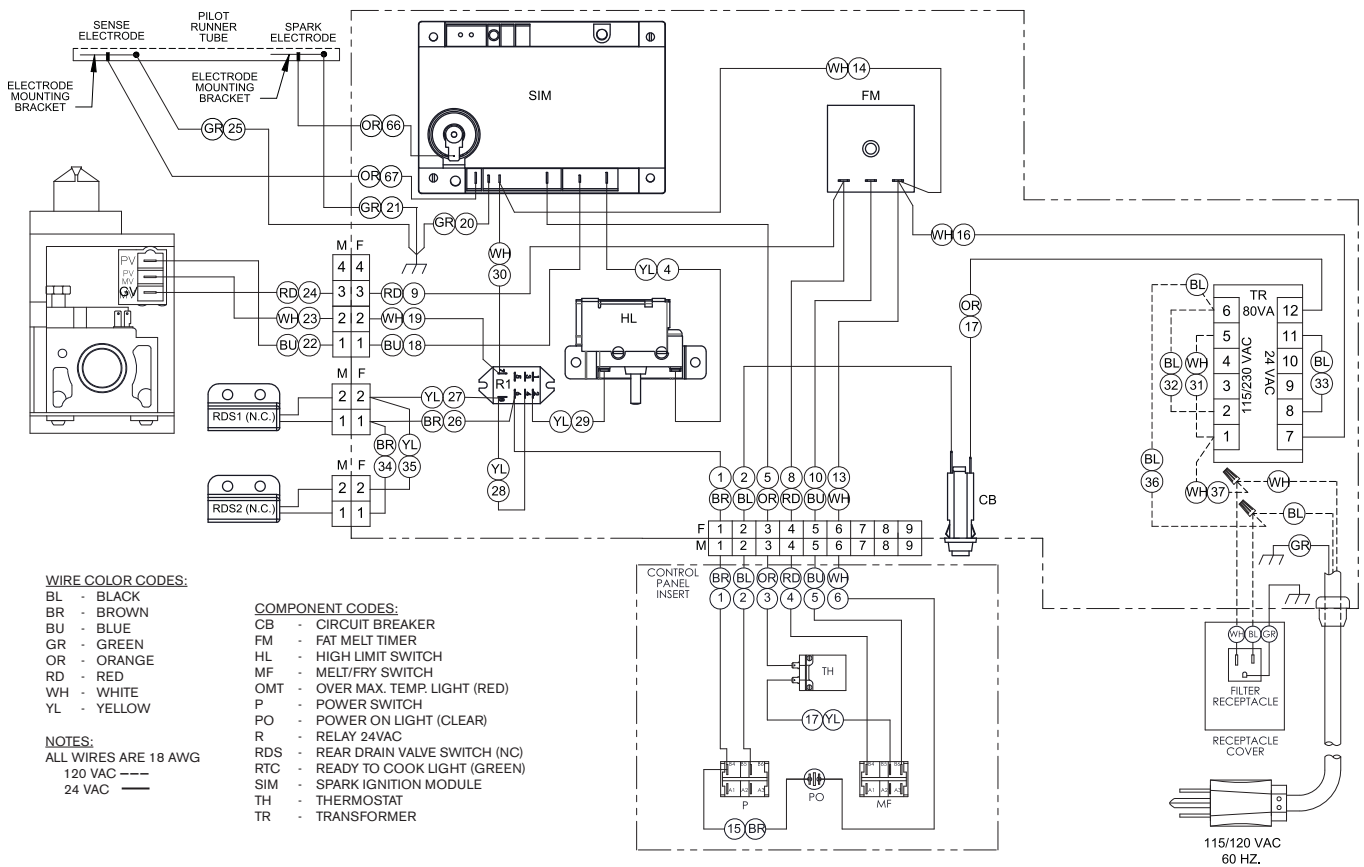

34x24 TS 2014 SPARK IGNITION ELECTRICAL ASSEMBLY - FRONT DRAIN

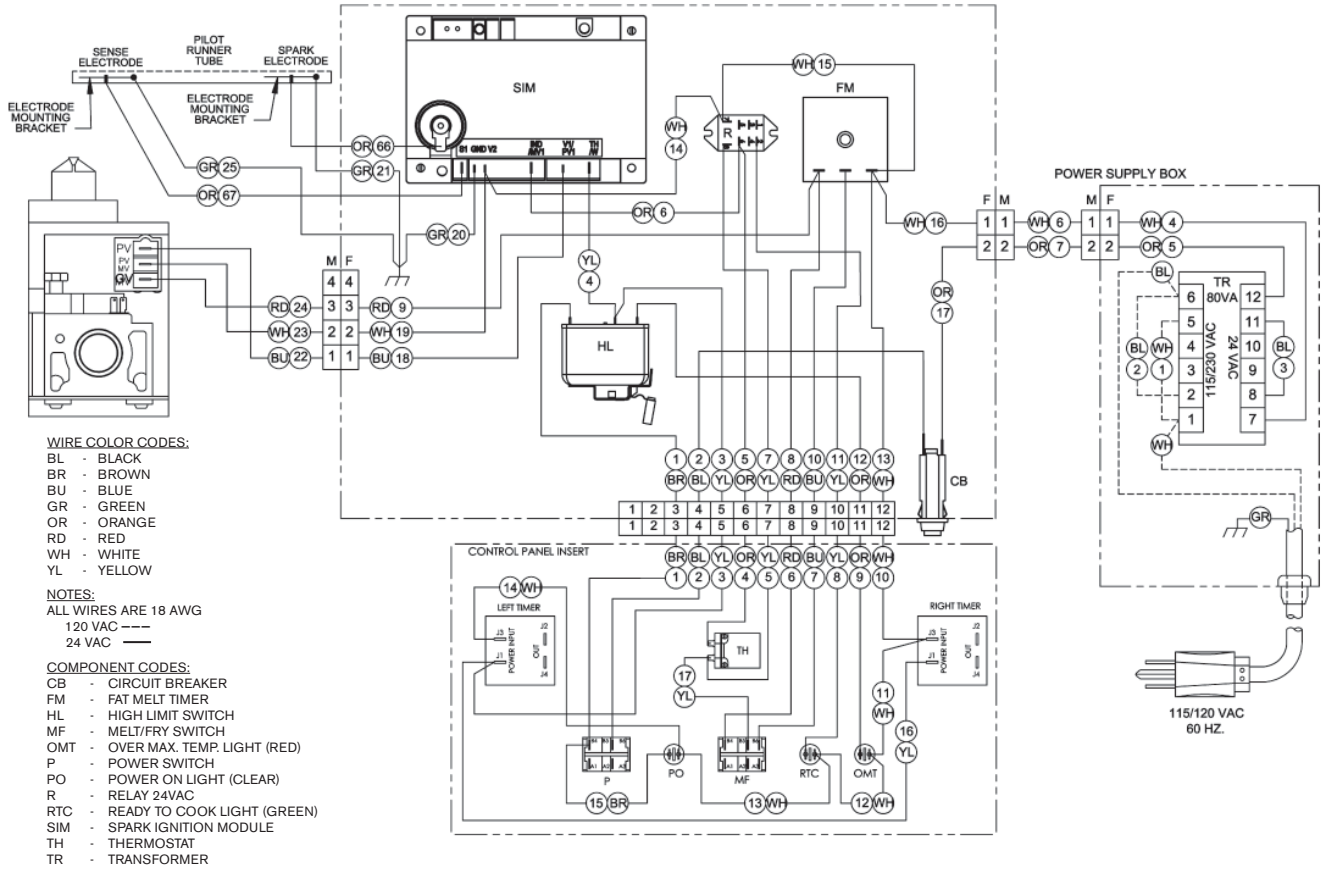

34x24 TS 2014 SPARK IGNITION ELECTRICAL ASSEMBLY - REAR DRAIN WITH SAFE & EASY® FILTER

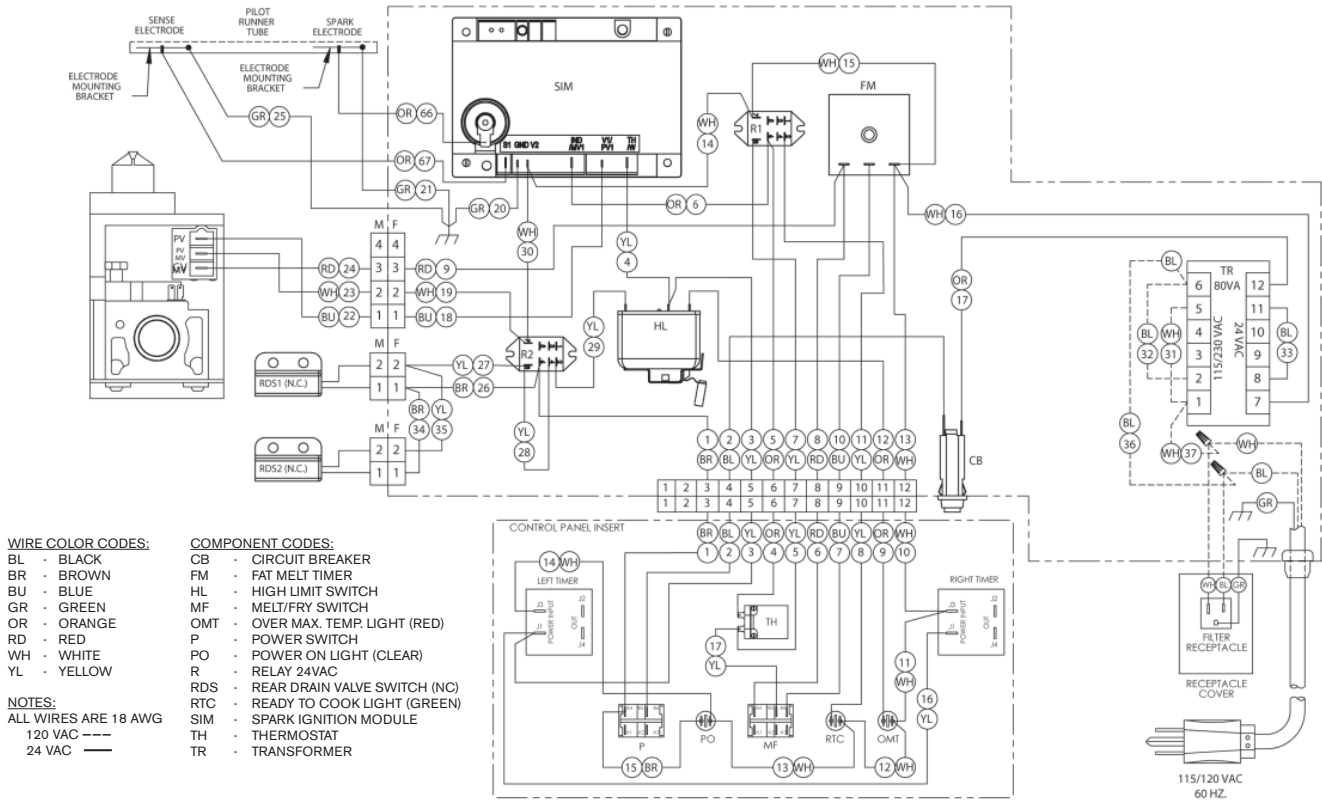

BASKET-LIFT ELECTRICAL ASSEMBLY - SERIES 2007

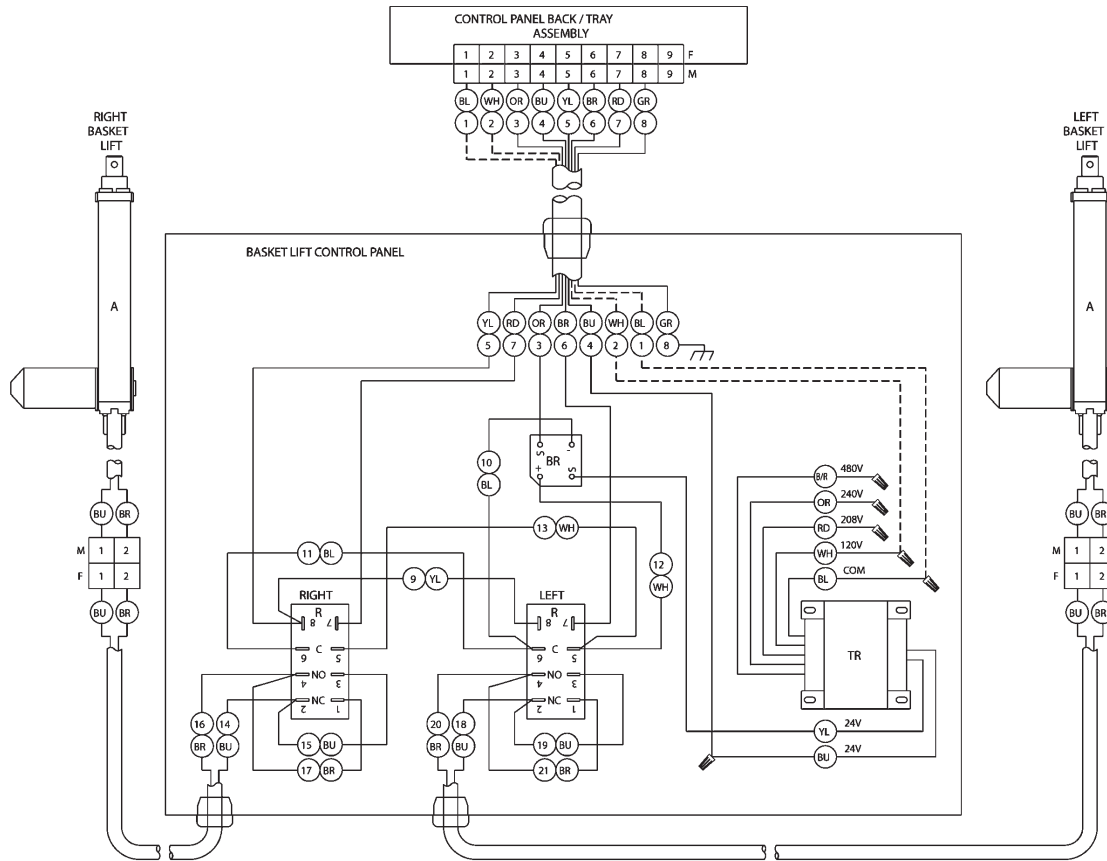

COMPONENT CODES:

- A - ACTUATOR
- BR - BRIDGE RECTIFIER
- R - RELAY 24VAC
- TR - TRANSFORMER (100VA)

WIRE COLOR CODES:

- BL - BLACK
- BR - BROWN
- B/R - BLACK/RED
- BU - BLUE
- GR - GREEN
- OR - ORANGE
- RD - RED
- WH - WHITE
- YL - YELLOW

120 VAC ---
24 VAC & VDC —

NOTES:

- ALL WIRES ARE 18 AWG
- THIS DIAGRAM SHOWN 120VAC SUPPLY VOLTAGE



WARRANTY

LIMITED WARRANTY

Keating of Chicago, Inc. ("Keating") warrants to the original purchaser. ("Customer"), all new Keating Fryers, Filter Systems, Griddles, Keep Krisp®, Custom Pasta Systems, Top-Side™ Cookers, Computer Timers, Fryer & Pasta Vessels and Keating replacement parts ("products") installed after June 1, 1994 to be free to defects in material or workmanship, subject to the following terms and conditions.

LENGTH OF WARRANTY

All products other than Fryer & Pasta Vessels and replacement parts shall be warranted for a period of one year from the date of original equipment installation. Keating replacement parts are warranted for a period of ninety days from the date of installation. Fryer & Pasta Vessels are warranted as described below.

FRYER & PASTA VESSEL WARRANTY

Fryers purchased after June 1, 1994 carry a prorated vessel warranty on defects in materials or workmanship to the Customer based on the following scale:

<i>Time from Installation Date</i>	<i>Fryer Vessel Warranty Credit</i>
13-60 months	100%
61-72 months	80%
73-84 months	60%
85-96 months	40%
97-108 months	20%
109-120 months	10%

The credit for the defective fryer & pasta vessel shall be applied against the cost of the replacement vessel, utilizing Keating's then current price, upon return of the vessel to Keating, (freight to be paid by Keating within the first 12 months only), only during the first 60 months, subject to the limitations described below.

LIMITATIONS OF LIABILITY

In the event of warranty claim or otherwise, the sole obligation of Keating shall be the repair and / or replacement at the option of Keating of the product or component or part thereof. Such repair or replacement shall be at the expense of Keating except that the Customer shall pay the following expenses: all freight and labor expense for Keating replacement parts; for all other products, mileage exceeding 50 miles or travel more than one hour, labor costs of more than one person, overtime rates, truck charges, difference between ground and other mode of transportation, and holiday charges. Any repair or replacement under this Limited Warranty does not constitute an extension of the original warranty for any period for the product or for any component or part thereof. Parts to be replaced under this Limited Warranty will be repaired at the option of Keating with new or functionally operative parts. Keep Krisps and Computer Timers must be returned to Keating for warranty repair or replacement. Field repairs of those items are not authorized.

THE LIABILITY OF KEATING ON ANY CLAIM OF ANY KIND, INCLUDING CLAIMS BASED ON WARRANTY, EXPRESSED OR IMPLIED, CONTRACT, NEGLIGENCE, STRICT LIABILITY OR ANY OTHER THEORIES SHALL BE SOLELY AND EXCLUSIVELY THE REPAIR OR REPLACEMENT OF THE PRODUCT AS STATED HEREIN, AND SUCH LIABILITY SHALL NOT INCLUDE, AND CUSTOMER SPECIFICALLY RENOUNCES ANY RIGHTS TO RECOVER, SPECIAL, INCIDENTAL, CONSEQUENTIAL OR OTHER INJURIES TO PERSONS OR DAMAGE TO PROPERTY, LOSS OF PROFITS OR ANTICIPATED PROFITS, OR LOSS OF USE OF THE PRODUCT.

If any oral statements have been made regarding the Keating products, such statements do not constitute warranties and are not part of the contract sale. This Limited Warranty constitutes the complete, final and exclusive statement with regard to warranties.

THIS LIMITED WARRANTY IS EXCLUSIVE AND IS IN LIEU OF ALL OTHER WARRANTIES WHETHER WRITTEN, ORAL, STATUTORY OR IMPLIED, INCLUDING BUT NOT LIMITED TO ANY WARRANTY OF MERCHANTABILITY OR FITNESS FOR PARTICULAR PURPOSE OR WARRANTY AGAINST LATENT DEFECTS.

EXCLUSIONS

The warranties provided by Keating of Chicago, Inc. do not apply in the following instances:

1. Defects arising out of or resulting from improper installation or maintenance, abuse, misuse, modification or alteration by unauthorized service personnel, or any other condition not attributable to a defect in material or workmanship. Proper installation and maintenance are the responsibility of the installer and Customer, respectively. Proper installation and maintenance procedures are prescribed by the Keating Service Manual.
2. In the event that the product was damaged after leaving the factory due to flood, fire, other acts of God or accident, damage during shipment should be reported to the carrier and is not the responsibility of Keating.
3. In the event the serial number or rating plate has been removed from the product or altered.
4. On parts which would normally be worn or replaced under normal conditions, including but not limited to electric bulbs, fuses, interior and exterior finishes, gaskets and radiants.
5. With regard to adjustments and calibrations such as leveling, tightening of fasteners or plumbing connections, improper gas pressure or improper electrical supply, the checking of and changes in adjustment and calibrations are the responsibility of the installer. Proper installation procedures are prescribed by the Keating Service Manual.
6. In the event of unauthorized repairs or alterations to the Keating product.
7. With the use of sodium chloride in pasta vessels or harsh chemicals in fryer or pasta vessels.
8. Installation in Household.

OTHER TERMS AND CONDITIONS

The Customer must provide proof of purchase from Keating.

This Limited Warranty is valid in the 50 United States, its territories, and Canada, and is void elsewhere.

Keating products are sold for commercial use only. If any Keating product is sold as a component of another product or used as a consumer product, such Keating product is sold As Is without any warranty.

If any provision of this Limited Warranty is held to be unenforceable under the law of any jurisdiction, such provision shall be inapplicable in such jurisdiction, and the remainder of the warranty shall remain unaffected. Further in such event, the maximum exclusion or limitation allowable under applicable law shall be deemed substituted for the unenforceable provision.

This Limited Warranty shall be governed by and construed in accordance with the laws of the State of Illinois.

TO SECURE WARRANTY SERVICE

All repair services under this Limited Warranty must be authorized by Keating or performed at Keating. Authorization may be obtained by calling 1-800-KEATING within the Continental United States, Alaska, Hawaii, Puerto Rico and Canada during normal business hours (8 a.m. through 5 p.m. Central Time, Monday through Friday). When calling, please have the following information available: (1) name, address and telephone number of the Customer; (2) location of product, if different; (3) name, model number and serial number of the product; (4) installation date; and (5) description of defect. Keating will then issue a service authorization work order number to one of its approved independent servicing organizations, or request the product or part be shipped to Keating for repair or replacement, as appropriate. Any defective part subject to a claim under this Limited Warranty must be shipped freight prepaid to Keating for testing and examination. Keating's decision as to the cause and nature of any defect under this Limited Warranty shall be final.

■ **SERVICE INFORMATION:**

If you have a service related question call **1-800-KEATING**.
Please state the nature of the call; it will ensure speaking with the appropriate person.

Have your serial and model number available when ordering parts.

As continuous product improvement occurs, specifications may be changed without notice.

.....
KEATING LIMITED WARRANTY CARD

PLEASE COMPLETE AND MAIL AT ONCE--WARRANTY IS NOT IN EFFECT UNTIL CARD IS RETURNED, OR COMPLETE THE WARRANTY CARD ON OUR WEBSITE FOR YOUR CONVENIENCE.

COMPANY: _____

ADDRESS: _____

CITY: _____ STATE: _____ ZIP CODE: _____

DEALER NAME: _____

DATE OF PURCHASE: _____ INVOICE #: _____

SERIAL #: _____ MODEL: _____

FRYER GRIDDLE CUSTOM PASTA
 FILTER SYSTEM TOP-SIDE COOKER HOTPLATE

I HAVE READ THE INSTALLATION AND OPERATING INSTRUCTIONS.

SIGNED: _____ DATE: _____



KEATING OF CHICAGO, INC.
8901 West 50th Street
McCook, IL 60525-6001

1-800-KEATING
PHONE: 708-246-3000
FAX: 708-246-3100

Serving Those Who Serve the Very Best®