



Electrical

Fusion™ Series

Installation Manual

Industrial Control Unit
Model 57550-400
Model 57551-400

New Information
December 2003



Important Notice – Please Read

The product discussed in this literature is subject to terms and conditions outlined in Eaton Electrical Inc. selling policies. The sole source governing the rights and remedies of any purchaser of this equipment is the relevant Eaton Electrical Inc. selling policy.

NO WARRANTIES, EXPRESS OR IMPLIED, INCLUDING WARRANTIES OF FITNESS FOR A PARTICULAR PURPOSE OR MERCHANTABILITY, OR WARRANTIES ARISING FROM COURSE OF DEALING OR USAGE OF TRADE, ARE MADE REGARDING THE INFORMATION, RECOMMENDATIONS AND DESCRIPTIONS CONTAINED HEREIN. In no event will Eaton Electrical Inc. be responsible to the purchaser or user in contract, in tort (including negligence), strict liability or otherwise for any special, indirect, incidental or consequential damage or loss whatsoever, including but not limited to damage or loss of use of equipment, plant or power system, cost of capital, loss of power, additional expenses in the use of existing power facilities, or claims against the purchaser or user by its customers resulting from the use of the information, recommendations and descriptions contained herein.

The information contained in this manual is subject to change without notice.

Cover Photo: Model 57550-400 Durant Fusion

December 2003



Table of Contents

LIST OF FIGURES	i
LIST OF TABLES	i
SAFETY	
Definitions and Symbols	ii
Warnings and Cautions	ii
INTRODUCTION	1
DESCRIPTION	
Count Module	2
Logic Control	2
Mounting Dimensions	3
WIRING AND DIP SWITCHES	4
SPECIFICATIONS	11
WARRANTY	13

List of Figures

Figure 1: Approximate Dimensions in Inches (mm)	3
Figure 2: Rear Terminal Layout	4
Figure 3: DC Power Input (for DC Powered Model 57550400)	5
Figure 4: AC Power Input (for AC Powered Model 57551400)	5
Figure 5: High Speed Counter Inputs I15 – I17 and DIP Switches	6
Figure 6: High Speed Counter Input DIP Switch	6
Figure 7: Control Inputs I1 – I10	7
Figure 8: Analog Inputs I11 – I14	7
Figure 9: Relay Outputs K1, K2 & K3	8
Figure 10: Relay Outputs K4 & K5	8
Figure 11: Transistor and Analog Outputs K6-K9	9
Figure 12: RS-232 Serial Port (DCE polarity)	9
Figure 13: RS-485 Serial Port	10

List of Tables

Table 1: DIP Switch Settings	7
Table 2: Fusion Technical Data	11

Safety

Definitions and Symbols

WARNING

This symbol indicates high voltage. It calls your attention to items or operations that could be dangerous to you and other persons operating this equipment. Read the message and follow the instructions carefully.



This symbol is the "Safety Alert Symbol." It occurs with either of two signal words: CAUTION or WARNING, as described below.

WARNING

Indicates a potentially hazardous situation which, if not avoided, can result in serious injury or death.

CAUTION

Indicates a potentially hazardous situation which, if not avoided, can result in minor to moderate injury, or serious damage to the product. The situation described in the CAUTION may, if not avoided, lead to serious results. Important safety measures are described in CAUTION (as well as WARNING).

Warnings and Cautions

WARNING

This device is an Open Type, Listed Process Control Equipment, and must be mounted in an overall enclosure.

WARNING

Disconnect all power before wiring terminals. **A safety hazard may exist if this precaution is not observed. Treat all power and output terminals as hazardous, since they may carry line voltage.**

CAUTION

This equipment generates, uses and can radiate radio frequency energy and if not installed and used in accordance with the instruction manual, may cause interference to radio communications. It has been tested and found to comply with the limits for a Class A computing device pursuant to Subpart J of Part 15 of FCC rules, which are designed to provide reasonable protection against such interference when operated in a commercial environment. Operation of this equipment in a residential area is likely to cause interference in which case the user at his own expense will be required to take whatever measures may be required to correct the interference.

December 2003

Introduction

This manual describes the installation of the Durant® Fusion from Eaton Electrical®, Catalog Numbers 57550-400 (10 – 30V DC) and 57551-400 (85 – 265V AC). Following a brief description of the control, this manual provides mounting and wiring information and specifications. A separate user manual, Part Number 57590-900, gives programming, operating and diagnostic information, and may be obtained by contacting the Durant Literature Department at 800-540-9242, option 3 (US and Canada), or 920-261-4070, option 3, or by fax at 920-261-9097. The user manual is also available from our website at www.durant.com.

Description

The Durant® Fusion from Eaton Electrical® is an industrial control unit consisting of a high speed count control module and a logic control capable of processing up to 100 rungs of ladder logic. The Fusion also features a multi-line, alphanumeric display and 18 front panel input keys as an operator interface. Configuration programming may be done using the display and keys, or may be accomplished by serially downloading from a PC.

Count Module

The count module has two dedicated count inputs and a high speed reset input. These inputs can be simultaneously used as ladder logic input contacts. The unit has 10 discreet control inputs that can be used as counter control inputs and/or ladder logic inputs. Four analog inputs, two 4 – 20 mA and two 0 – 10V, are dedicated to ladder comparators only.

The Fusion has three form C and two form A relay outputs, and two NPN transistor outputs. These outputs can be individually assigned to counter functions, or as ladder outputs. Two analog outputs, one 0 – 10V and one 4 – 20 mA, are also available. These outputs may be used as followers assigned to count or rate functions, or as open loop control outputs from the counter or the ladder.

The high speed count module is capable of counting at a sustained count speed of 6 kHz in any of 13 count modes. The module consists of a ratemeter and three counters, a main counter, a totalizer and a batch counter. The six digit main counter has up to five presets, plus prewarn. The eight digit totalizer and six digit batch counter each have a single preset, and the five digit ratemeter has two presets. Presets can be pre-loaded as "parameter sets" for programming recipes or for job stacking. Up to 10 parameter sets are available. Both the main counter and the totalizer are bi-directional (for up-down counting), and can be reset to zero, or to a selected offset value. The batch counter counts up only, and can be reset to zero only.

Logic Control

The ladder logic processor can process a program of up to 100 rungs. Each rung can contain up to six contacts and one coil. In addition to the 10 control inputs and three high speed count inputs, contacts also include:

- one power up signal
- 11 front panel keys
- eight analog comparators for use with the four analog inputs
- eight real time clock comparators
- seven digital and two analog outputs
- 16 memory bits
- 16 display and print messages
- eight counters
- eight timers
- one totalizer preset, one batch counter preset and two ratemeter presets (from the high speed counter)

December 2003

Coil types include:

- seven digital and two analog outputs
- 16 memory bits
- 16 display and print messages
- eight counters
- eight timers
- seven high speed counter inputs
- nine high speed counter output unlatches
- nine high speed counter output latches

Mounting Dimensions

⚠ WARNING

This device is an Open Type, Listed Process Control Equipment, and must be mounted in an overall enclosure.

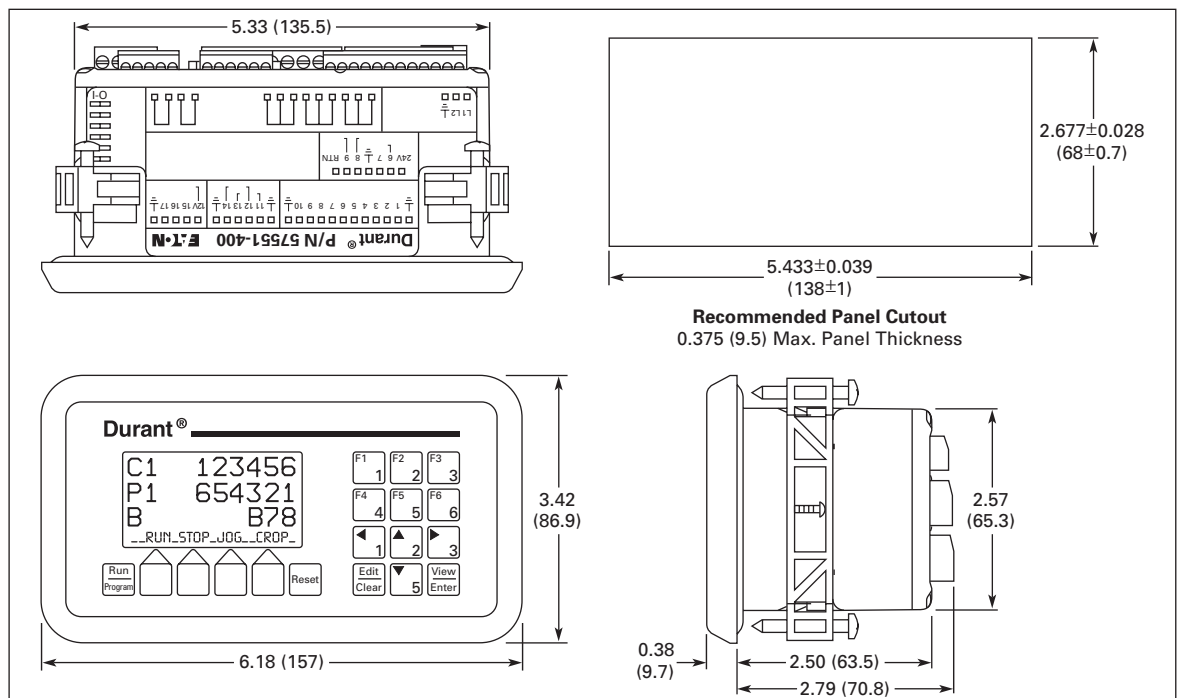

Figure 1: Approximate Dimensions in Inches (mm)

Mounting Instructions

1. Slide O ring gasket over unit body until it is tucked under the back of the front bezel.
2. Slide unit into cutout in panel.
3. Attach mounting clips and screws.

Tighten screws until the unit is firmly in place. **DO NOT OVERTIGHTEN** screws. Once the bezel makes contact with the panel, further tightening may break the bezel.

Wiring and DIP Switches

All wiring to the Fusion is done to rear terminal, de-pluggable connectors. There are nine headers on the back of the control to accept the wired connectors. The input and output terminals are grouped by function, such as Power In, Outputs 1 – 3, RS-485, etc. in the headers. Functions that are not needed for the application are simply left open. The same is true for individual terminals on connectors that are not used. The wiring to each connector, and the designation for each terminal is shown in the wiring diagrams below.

WARNING

Disconnect all power before wiring terminals. **A safety hazard may exist if this precaution is not observed. Treat all power and output terminals as hazardous, since they may carry line voltage.**

A switch shall be included in the building installation:

- It shall be in close proximity to the equipment and within easy reach of the operator.
- It shall be marked as the disconnecting device for the equipment.
- Switches and breakers in Europe must comply with IEC 947.

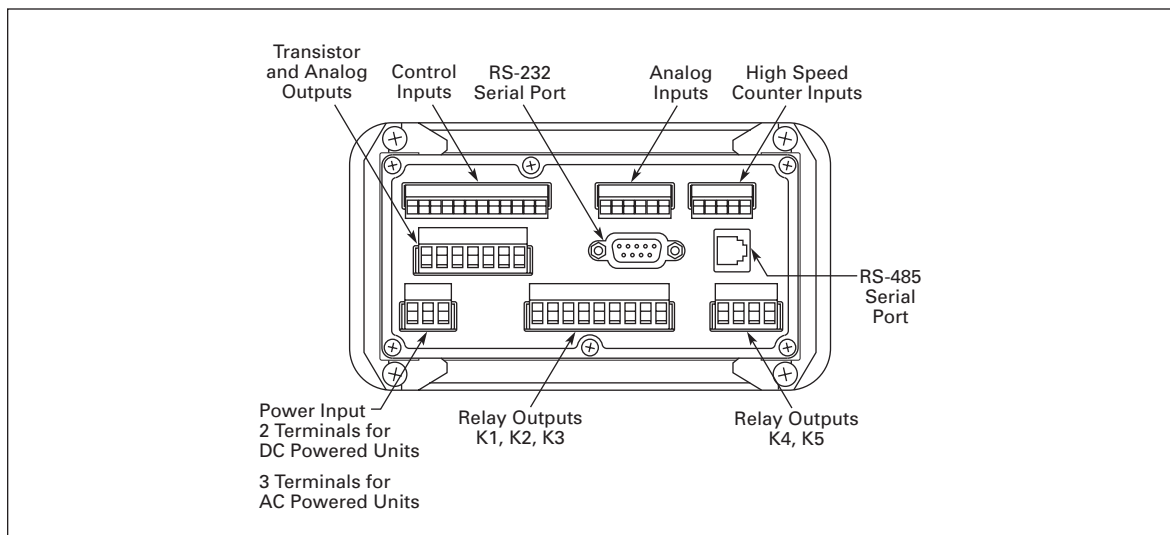

Figure 2: Rear Terminal Layout

General Wiring Guidelines

1. Keep all signal wires as short as possible.
2. Use shielded cable for signal wiring.
3. Connect shielded cable drain wires to earth or machine ground.
4. Do not bundle signal wires with power wiring.

December 2003

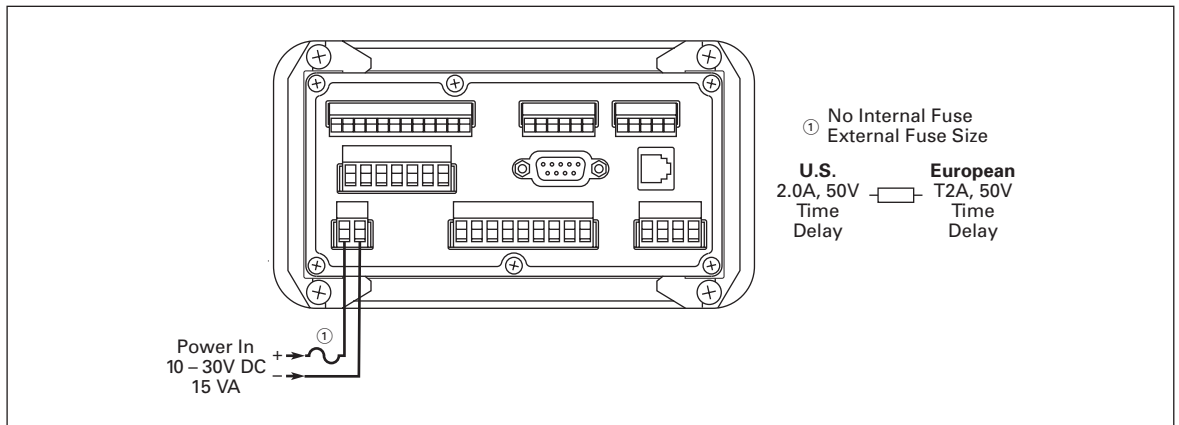

Figure 3: DC Power Input (for DC Powered Model 57550400)

Terminal ratings: 10A, 380V AC, wire size 12 – 24 AWG (3.1 mm² – 0.24 mm²) 600V

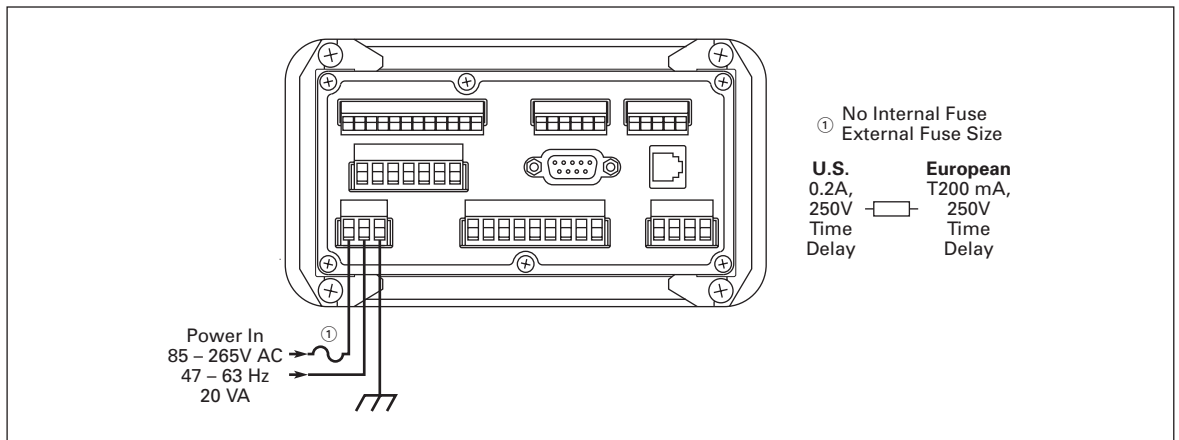

Figure 4: AC Power Input (for AC Powered Model 57551400)

Terminal ratings: 10A, 250V AC, wire size 12 – 24 AWG (3.1 mm² – 0.24 mm²) 600V

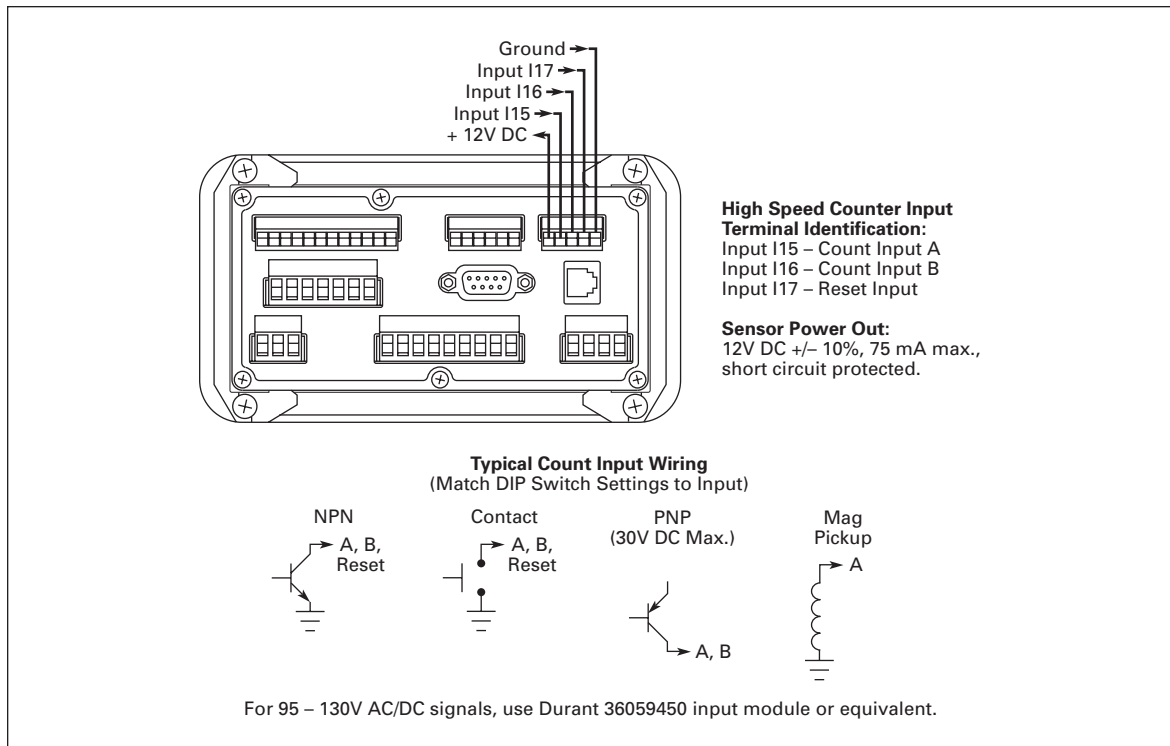

Figure 5: High Speed Counter Inputs I15 – I17 and DIP Switches

Terminal ratings: 8A, 125V AC, wire size 16 – 28 AWG (1.3 mm² – 0.1 mm²) 600V

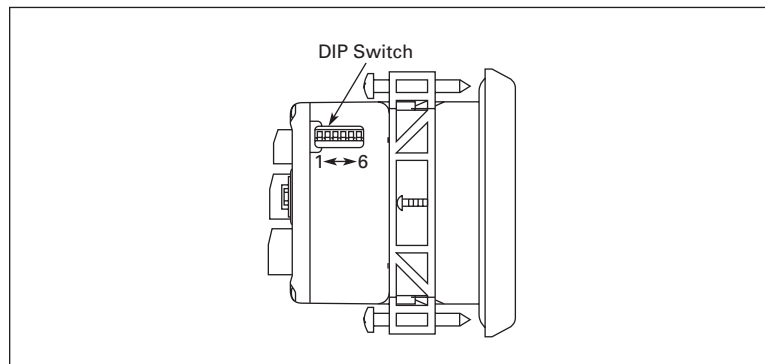

Figure 6: High Speed Counter Input DIP Switch

Set the DIP switches to electrically match the type of input wired to count inputs A and B, and the reset input. “Sink” refers to an NPN or contact input as shown in **Figure 5**. “Source” refers to a PNP input as shown in **Figure 5**. For any of the inputs used, set all of the switches for that input to the proper setting as determined by **Table 1**. If a mag input is wired to input A, switch 1 must be set to Source. Slow response is 140 Hz maximum for NPN, push-pull, and mag inputs, and 60 Hz maximum for PNP inputs. Fast response is 14 kHz maximum.

December 2003

Table 1: DIP Switch Settings

DIP Switch Number	"1" Setting	"0" Setting
1	A Input Sink	A Input Source
2	A Input Slow Response	A Input Fast Response
3	A Input Mag Pickup	A Input Single Ended
4	B Input Sink	B Input Source
5	B Input Slow Response	B Input Fast Response
6	Reset Input Slow Response	Reset Input Fast Response

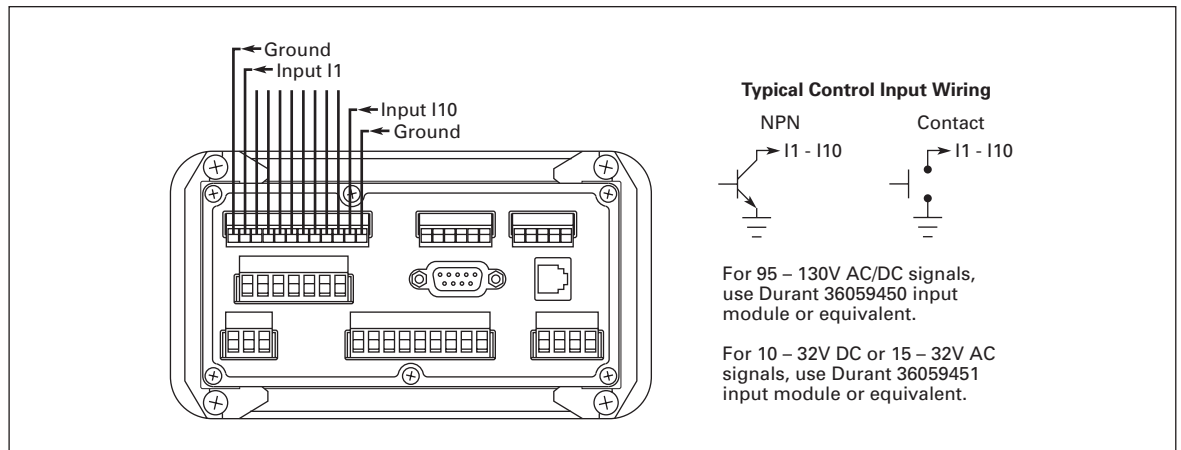

Figure 7: Control Inputs I1 - I10

Terminal ratings: 8A, 125V AC, wire size 16 - 28 AWG (1.3 mm² - 0.1 mm²) 600V

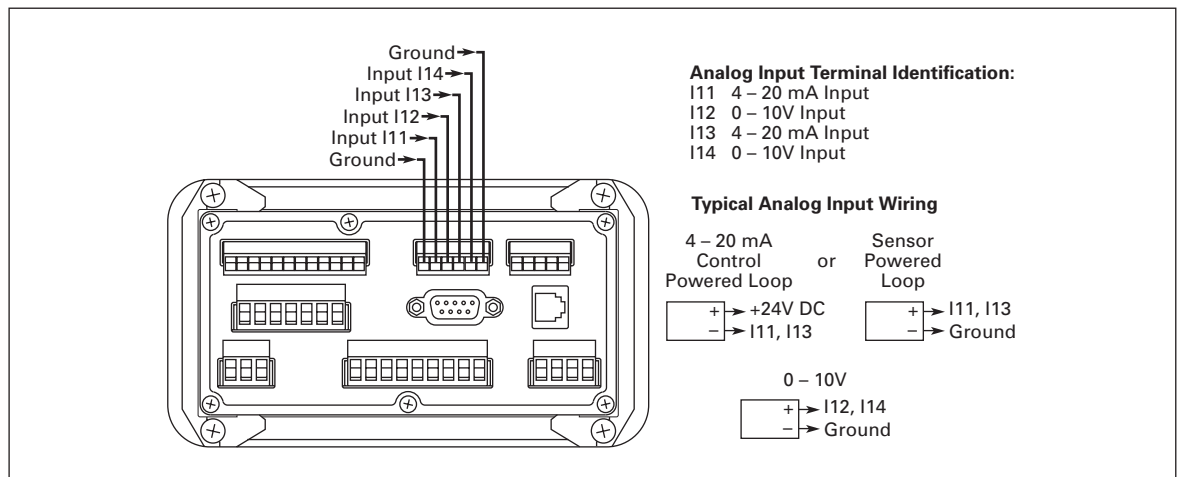

Figure 8: Analog Inputs I11 - I14

Terminal ratings: 8A, 125V AC, wire size 16 - 28 AWG (1.3 mm² - 0.1 mm²) 600V

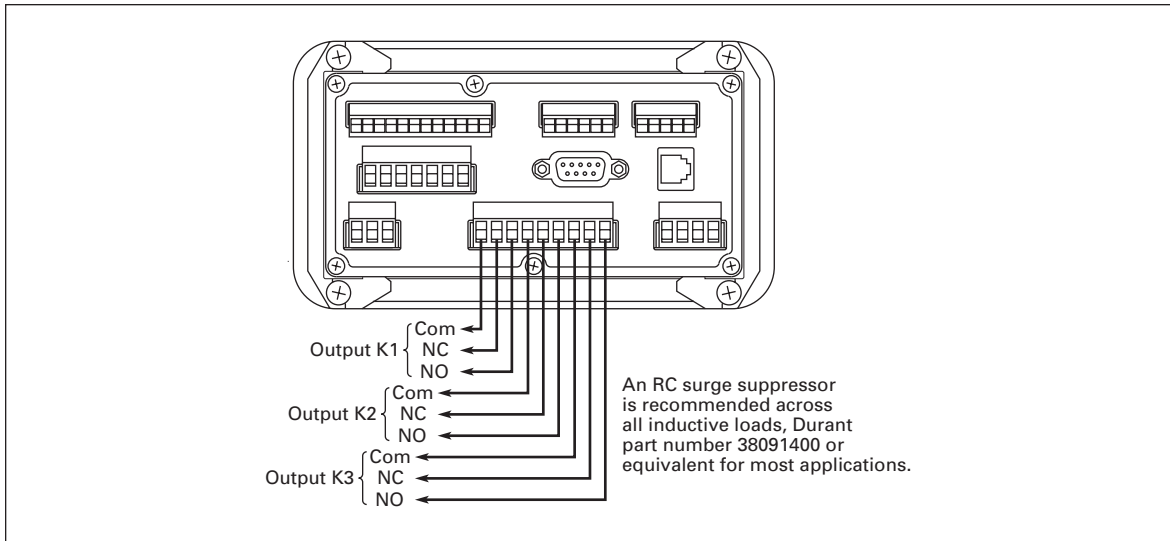

Figure 9: Relay Outputs K1, K2 & K3

Terminal ratings: 10A, 250V AC, wire size 12 – 24 AWG (3.1 mm² – 0.24 mm²) 600V

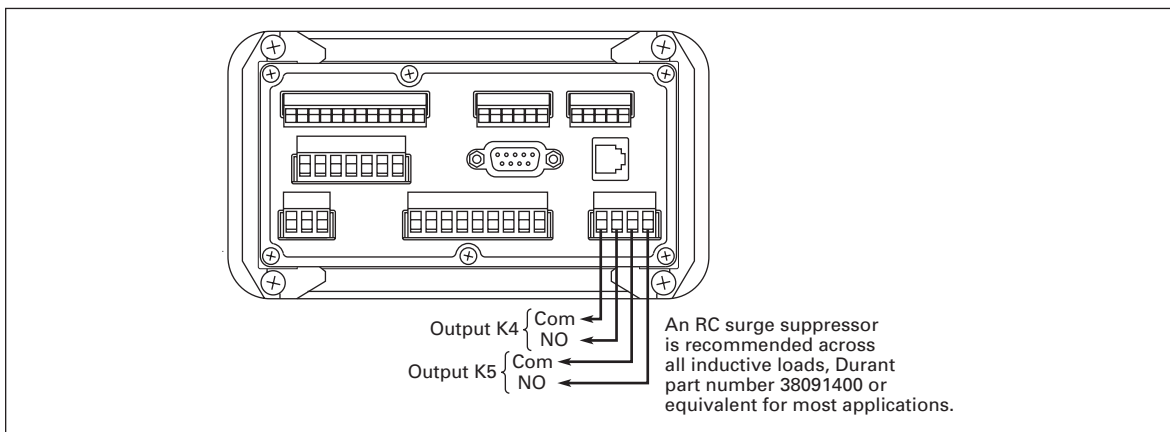

Figure 10: Relay Outputs K4 & K5

Terminal ratings: 10A, 250V AC, wire size 12 – 24 AWG (3.1 mm² – 0.24 mm²) 600V

December 2003

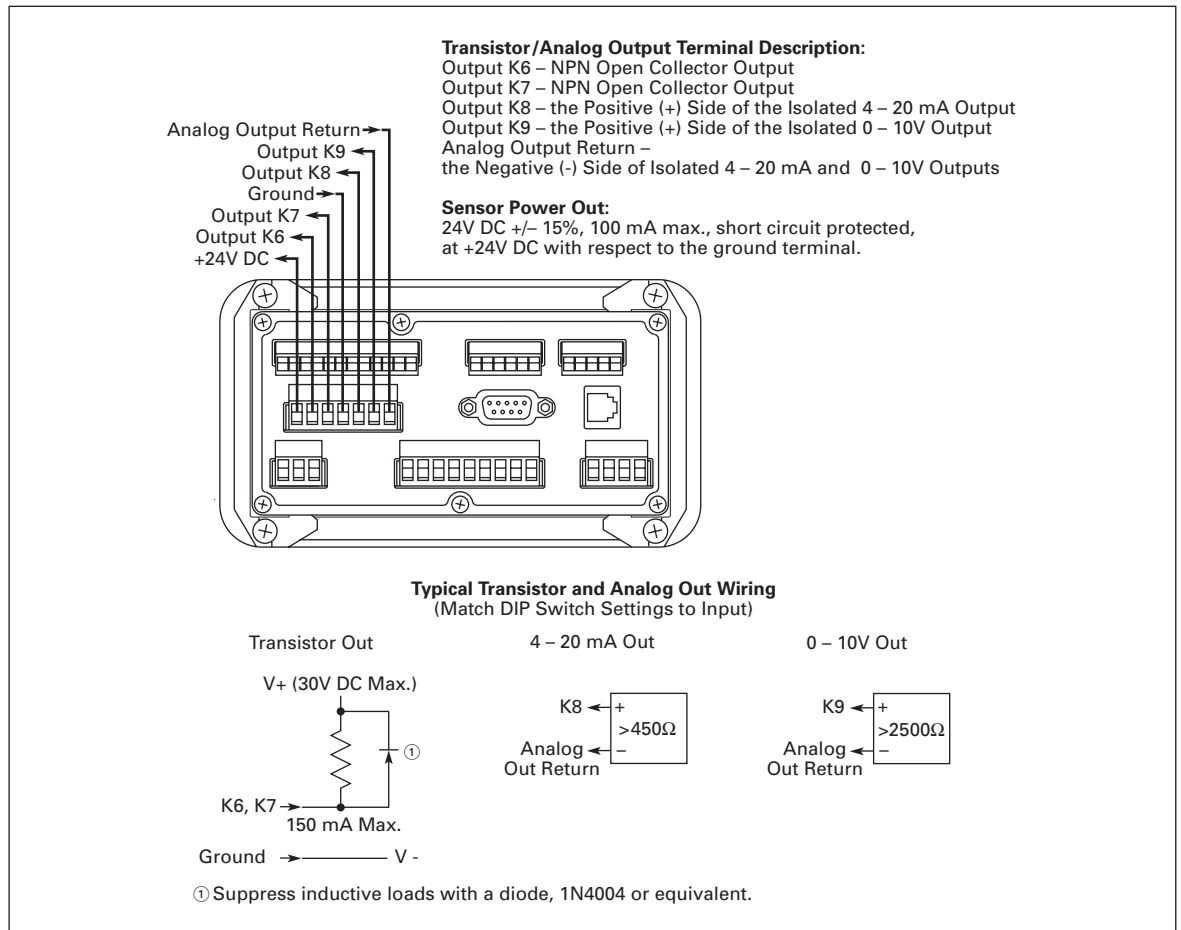

Figure 11: Transistor and Analog Outputs K6 – K9

Terminal ratings: 10A, 250V AC, wire size 12 – 24 AWG (3.1 mm² – 0.24 mm²) 600V

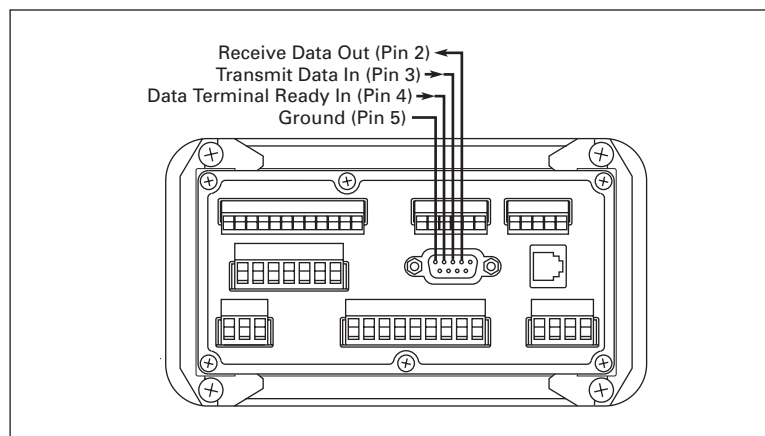

Figure 12: RS-232 Serial Port (DCE polarity)

Mating connector: DB-9P

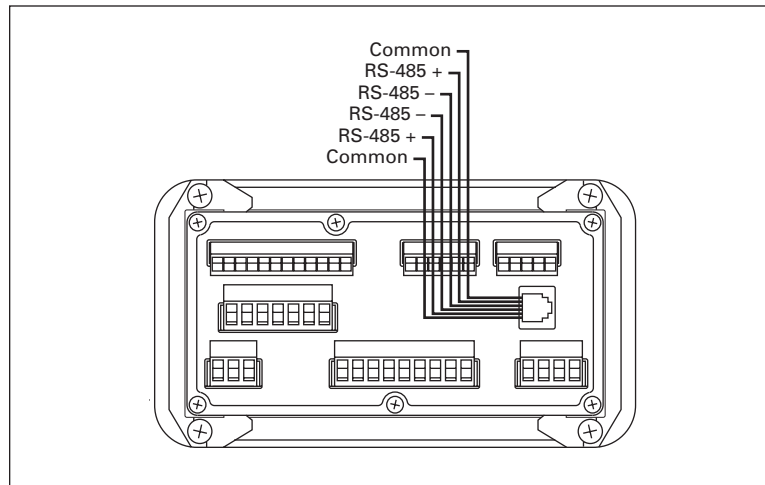

Figure 13: RS-485 Serial Port

Mating connector: RJ-12 plug

Typical wiring: Both commons are connected inside the control, as are both RS-485+ terminals, and both RS-485- terminals. Connect all devices on the RS-485 network + to +, - to -, and common to common, using three-conductor cable.

December 2003

Specifications

Table 2: Fusion Technical Data

Description	Specifications
Environmental	
Operation	Indoor use to 2000m
Temperature	32° to 122°F (0° to 50°C) operating; -4° to 158°F (-20° to 70°C) storage
Humidity	0 to 85% RH, non-condensing
Vibration	2.5 Gs, 30 – 200 Hz
Shock	30 Gs, 11 mS half sinewave
EMC	EN61326:1997 All I/O lines except RS-485 <30m
Front Panel	Type 4X indoor use only, when mounted with gasket provided
Safety	UL, cUL Listed, CE Compliant
Mechanical	
Cutout	138 mm x 68 mm DIN standard
Outline	157 mm x 87 mm x 81 mm
Panel depth	72 mm maximum
Enclosure	Polycarbonate/ABS
Label	Polyester
Input Power	
AC Model	85 – 265V AC, 47 – 63 Hz, 20 VA; Isolation 2300V AC
DC Model	10 – 30V DC, 15 VA
Inputs	
Control: Number Impedance Thresholds	10 4.75k Ohms to +5V DC High 3.5 – 30V DC; Low 0 – 1.0V DC
Counter: Number Impedance Thresholds Response	3 (including reset) 4.75k Ohms to +5V DC or 26.9k Ohms to ground High 3.5 – 30V; Low 0 – 1.5V, or 200 mV p-p to 50V rms @ 26.9k Ohms (mag pickup) 140 Hz or 14 kHz for sinking, push-pull or mag pickup inputs 60 Hz or 6 kHz for sourcing only inputs All frequencies based on 50-50 duty cycle 6 kHz maximum sustained count speed
Analog: Number Type Accuracy Impedance Overrange	4 4 – 20 mA and two 0 – 10V DC +/- 0.5% FS and +/- 200 PPM/°C 100 Ohms (current input), 1.27M Ohms (voltage input) 45 mA maximum (current input), 20V maximum (voltage input)

Table 2: Fusion Technical Data (continued)

Description	Specifications
Outputs	
Power	24V DC +/- 15%, 100 mA maximum, short circuit protected 12V DC +/- 10%, 75 mA maximum, short circuit protected
Relays: Number Contacts Isolation	3 (Form C), 2 (Form A) 5A, 250V AC, 30V DC 2300V AC
Transistors: Number Type Ratings	2 NPN Darlington 150 mA maximum ON current, 30V DC maximum OFF voltage
Analog: Number Type Accuracy Common Mode Voltage Rating Isolation	2, short circuit protected 4 – 20 mA (<450 Ohms), 0 – 10V (>2500 Ohms) +/- 0.5% FS and +/- 200 PPM/°C 250V AC 2300V AC
RS-232: Connector Polarity Baud Rate	DB-9S DCE 1200 – 19200
RS-485: Connector Baud Rate	6 wire RJ-12 phonejack 1200 – 19200
Data Retention	
Program Data: Type Duration	Non-volatile 100 Years, no batteries
Real Time Clock: Type Charge Time Retention	Capacitor 3 Minutes 1 – 5 Days
Human Interface	
Display: Type Character Size	128 x 64 pixel graphic LCD with LED backlight 0.12" high, 21 characters per line, 6 lines maximum 0.24" high, 10 characters per line, 3 lines maximum 0.35" high, 7 characters per line, 2 lines maximum
Keys: Number Type	18 membrane switches with tactile feedback
Real Time Clock Format	Seconds, minutes, hours, day and date

December 2003

Warranty

Seller warrants that the Products manufactured by it will conform to Seller's applicable specifications and be free from failure due to defects in workmanship and material for one (1) year from the date of installation of the Product or eighteen (18) months from the date of shipment of the Product, whichever occurs first.

In the event any Product fails to comply with the foregoing warranty Seller will, at its option, either (a) repair or replace the defective Product, or defective part or component thereof, F.O.B. Seller's facility freight prepaid, or (b) credit Buyer for the purchase price of the Product. All warranty claims shall be made in writing. Seller requires all non-conforming Products be returned at Seller's expense for evaluation unless specifically stated otherwise in writing by Seller.

This warranty does not cover failure or damage due to storage, installation, operation or maintenance not in conformance with Seller's recommendations and industry standard practice or due to accident, misuse, abuse or negligence. This warranty does not cover reimbursement for labor, gaining access, removal, installation, temporary power or any other expenses which may be incurred in connection with repair or replacement.

This warranty does not apply to equipment not manufactured by Seller. Seller limits itself to extending the same warranty it receives from the supplier.

Limitation on Warranties for Products, Services and Power Systems Studies

THE FOREGOING WARRANTIES ARE EXCLUSIVE EXCEPT FOR WARRANTIES OF TITLE AND AGAINST PATENT INFRINGEMENT. SELLER DISCLAIMS ALL OTHER WARRANTIES INCLUDING ANY IMPLIED WARRANTIES OF MERCHANTABILITY AND FITNESS FOR A PARTICULAR PURPOSE.

CORRECTION OF NON-CONFORMITIES IN THE MANNER AND FOR THE PERIOD OF TIME PROVIDED ABOVE SHALL CONSTITUTE SELLER'S SOLE LIABILITY AND BUYER'S EXCLUSIVE REMEDY FOR FAILURE OF SELLER TO MEET ITS WARRANTY OBLIGATIONS, WHETHER CLAIMS OF THE BUYER ARE BASED IN CONTRACT, IN TORT (INCLUDING NEGLIGENCE OR STRICT LIABILITY), OR OTHERWISE.

Company Information

Eaton Electrical Inc. is a global leader in electrical control, power distribution, and industrial automation products and services. Through advanced product development, world-class manufacturing methods, and global engineering services and support, Eaton Electrical® provides customer-driven solutions under brand names such as Cutler-Hammer®, Durant®, Heinemann®, Holec® and MEM®, which globally serve the changing needs of the industrial, utility, light commercial, residential, and OEM markets. For more information, visit www.eatonelectrical.com.

Eaton Corporation is a global diversified industrial manufacturer with 2002 sales of \$7.2 billion that is a leader in fluid power systems; electrical power quality, distribution and control; automotive engine air management and fuel economy; and intelligent drivetrain systems for fuel economy and safety in trucks. Eaton has 51,000 employees and sells products in more than 50 countries. For more information, visit www.eaton.com.

Eaton Electrical
1000 Cherrington Parkway
Moon Township, PA 15108-4312
USA
tel: 1-800-525-2000
www.eatonelectrical.com

Durant Products
901 S. 12th Street
Watertown, WI 53094
USA
tel: 1-920-261-4070
tel: 1-800-540-9242
www.durant.com