

RJ MOBILITY LTD.

MINI-METEOR USER MANUAL

**THE WHEELCHAIR THAT PROVIDES
ACTIVE USER INDEPENDENCE
FOR A CHILD**

Before using your wheelchair please read this manual as it contains important information for the assembly, transportation and use of your wheelchair.

Thank you for choosing a Mini-Meteor lightweight active user wheelchair. We hope that it will provide many enjoyable years of reliable service and fulfil all your mobility needs.

This user manual should be read carefully before you use your wheelchair.

This user manual contains important information regarding the safe operation and maintenance of your Mini-Meteor lightweight active user wheelchair. Please make sure that you understand all the instructions thoroughly.

If you fail to understand anything or have any questions concerning operation and maintenance, please contact your supplier who will provide you with expert professional advice.

R J Mobility Limited is a quality approved manufacturer to BS5750 Part 2/ISO 9002.

This product is manufactured to comply with the essential requirements of the Medical Devices Directive 93/42 EEC.



In line with our policy of continuous improvement we welcome any suggestions that could lead to product improvement.

CONTENTS

Item		Page
1	INTRODUCTION	
2	USER CATEGORIES	
3	PARTS IDENTIFICATION	
4	UNFOLDING AND PREPARING FOR USE	
5	FOLDING FOR STORAGE OR TRAVEL	
6	PUSH HANDLES	
7	ATTENDANT PUSHING	
8	GETTING IN AND OUT OF YOUR WHEELCHAIR	
9	GETTING IN FROM THE FRONT	
10	GETTING OUT FROM THE FRONT	
11	SIDE TRANSFER TO A WHEELCHAIR	
12	SIDE TRANSFER FROM A WHEELCHAIR	
13	USING YOUR WHEELCHAIR : DO'S AND DON'TS	
14	ASCENDING AND DESCENDING SLOPES	
15	ASCENDING AND DESCENDING KERBS	
16	UNEVEN, SLIPPERY AND SOFT SURFACES	
17-22	CARE AND MAINTENANCE	
23	FACTORY FITTED OPTIONS	
24	ACCESSORIES	
25	SERVICE HISTORY	
26	WARRANTY	

1. INTRODUCTION

The Mini-Meteor is a lightweight active user wheelchair designed to combine rigidity with a high degree of manoeuvrability. The Mini-Meteor is intended for everyday indoor and outdoor use by a child whose weight should not exceed 75Kg (12 stone).

Primarily for use and control by the occupant the Mini-Meteor has 51cm (20") diameter quick release rear wheels fitted with pneumatic or puncture proof tyres and hand rims for user self propulsion.

The Mini-Meteor is painted in a choice of durable powder-coated colour finishes. Seating and backrest materials are flame retardant nylon.

1.1 WHEELCHAIR TRANSPORTATION IN MOTOR VEHICLES

All of the wheelchairs in our range are designed to be easily transported and most of them dismantle into manageable parts in seconds.

Consideration should be given to the type of vehicle in which the wheelchair may be carried. A small car with a heavy power chair in the boot may be affected in the way in which it steers or brakes, so care should be taken to distribute the load sensibly.

It should also be noted that even a lightweight manual wheelchair has considerable mass in the event of emergency braking and some form of restraint is essential when transporting any wheelchair in any vehicle.

It is strongly recommended that the user transfers to a vehicle seat and the wheelchair is transported separately. However, if this is not possible and the user intends to travel in a moving vehicle whilst seated in the wheelchair, ***it is essential they follow clear safety guidelines and understand that this is not as safe as using the vehicle seat.***

Many of our wheelchairs have been shown to withstand simulated crash conditions without injury to the user. We have compiled a separate document describing the conditions in which these tests were carried out and clearly detailing the manner in which the wheelchair should be restrained. ***Any wheelchair restraints must be separate to the user restraints.***

It is the responsibility of the transport operator and the wheelchair user to ensure that safety measures taken are suitable for both the wheelchair user and other passengers.

All passengers in motor vehicles accept that risk is involved in travel but this is compounded by wheelchair use. The wheelchair brakes are not designed to withstand forces such as cornering, acceleration and braking within a motor vehicle, therefore additional special restraints must be provided.

The wheelchair should be secured to the vehicle floor in-line with the direction of travel. The occupant should be separately restrained to the vehicle and NOT to the wheelchair. Installers and operators of restraint systems should be trained in their correct use by the restraint manufacturer, or approved specialist. Additional fittings such as trays should be removed and stowed separately. It is recommended that wheelchairs with a full height backrest are used.

R J Mobility have undertaken crash testing to latest known international standard test methods and recommend the use of the Unwin 4 - Point Tie Down system. The following wheelchairs have been tested and we have published details which are available upon request.

Barrett 7H
Barrett 10H
Meteor (additional back support is recommended)
Mini-Meteor
Maxi
Independent

Other products in our range and R J Mobility products manufactured prior to testing have been used to transport users in motor vehicles over many years without serious incident and it must be decided by the user/carer whether to continue to do so. ***It is not as safe as travelling in a vehicle seat and there are risks involved.*** These are minimised with the use of effective recommended equipment/restraints and our company believes in freedom of choice for informed individuals so please be aware of the risks and make your own informed choice.

To obtain free written details of the tests we have carried out, please write to:

RJ Mobility Limited
Boy Lane
Wheatley
Halifax
HX3 5AF
England

2. USER CATEGORY FOR THE MINI-METEOR LIGHTWEIGHT ACTIVE USER WHEELCHAIR

- A1 Occupant with all limbs intact and having the ability to co-ordinate both arms and hands with sufficient strength to self-propel and control the wheelchair safely and maintain an upright seating position.
- A3 Occupant with sufficient upper body control who can maintain an upright seating position.

IMPORTANT

The above identifies the minimum user characteristics suitable for the Mini-Meteor Lightweight Active User Wheelchair.

3. WHEELCHAIR PARTS IDENTIFICATION FOR MINI-METEOR LIGHTWEIGHT ACTIVE USER CHILD'S WHEELCHAIR

Once the packaging has been removed, check for missing parts against the diagram below and inspect for damage to the more fragile parts such as: handrims, spokes, seat and back upholstery and footrest assembly. There should be nothing bent or broken.

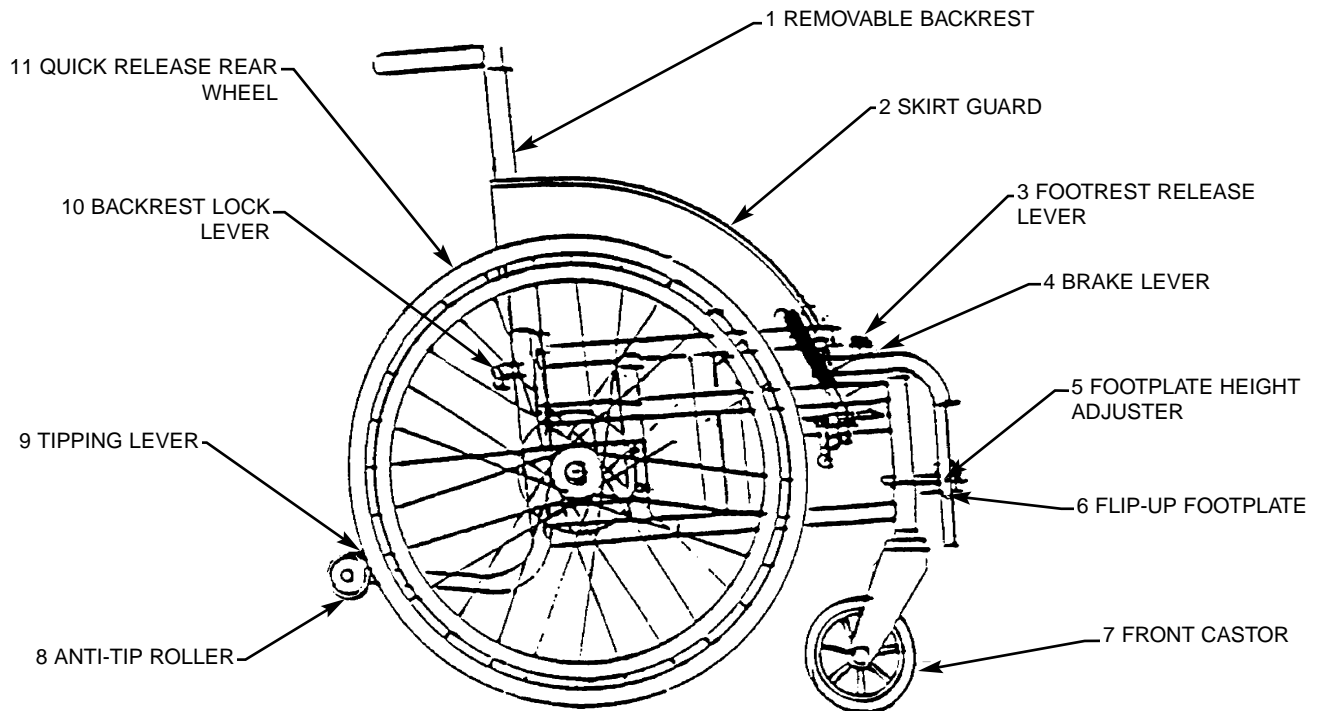

Please contact your supplier immediately if the wheelchair is not to your satisfaction.

4. UNFOLDING, ASSEMBLING AND PREPARING THE MINI-METEOR WHEELCHAIR FOR USE

It may be advisable to have the wheelchair prepared for use for the first time by an able bodied assistant. Until the folding components have lost some of their stiffness, the wheelchair may require moderate strength and effort to assemble it properly. No tools are necessary for the assembly of your wheelchair and the procedure is as follows.

1 Wheel Removal and Refitting

In order to release the side skirts, remove the quick release wheels and re-fit them. Lift the frame with one hand and the wheel with the other hand. Hold the spokes surrounding the hub and fully depress the centre button. Pull the wheel from the axle bush and release the centre button. You can now lift up the side skirts. To refit the wheel, press the centre button in and insert the axle fully into the axle bush and release the centre button (see FIG 1).

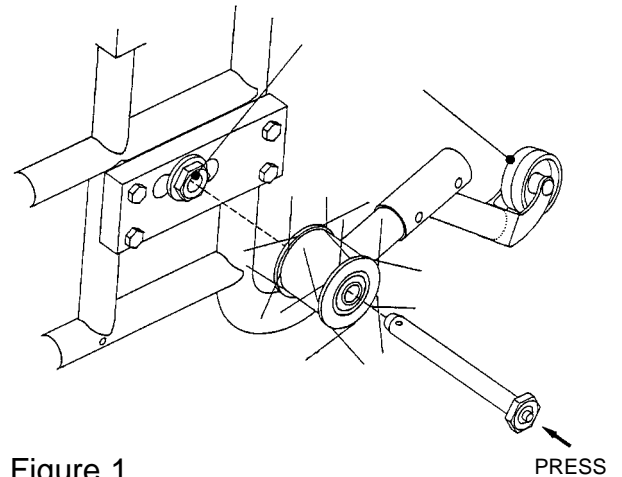

Figure 1

IMPORTANT

Always ensure that the wheel is fully locked. Pull the wheel outwards without depressing the centre button. If located correctly the wheel will not come off.

2 Apply the brake by pushing lever (A) forward (see FIG 2).

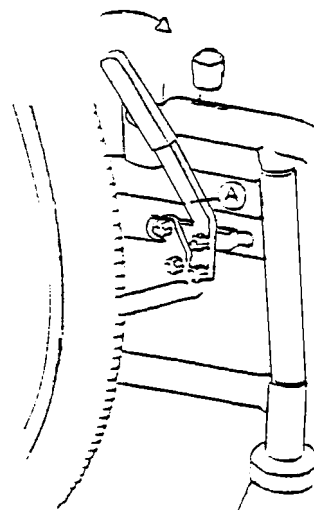

Figure 2

- 3 Stand at one side of the folded Mini-Meteor. Tilt it slightly to balance on one rear wheel and simultaneously press down on the opposite side of the seat and push until the wheelchair is fully open. **Check that the seat tubes (A) have located into their cradles (B)** (see FIG 3).

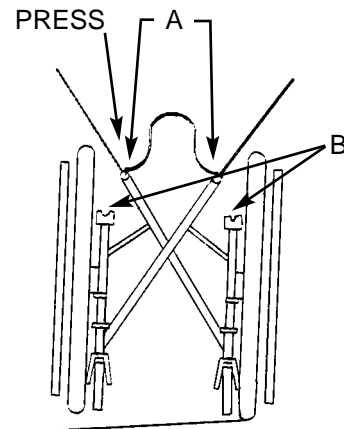

Figure 3

IMPORTANT

Ensure that your fingers are kept above the level of the seat to avoid trapping them between the seat tube and the wheelchair frame.

- 4 Fit the backrest by rotating the lever (B) at each side of the wheelchair to point upwards and slide the backrest fully into position; rotate the two levers (B) to point downwards thus locking the backrest (see FIG 4). Check that the backrest is securely fitted by lifting it upwards. It should not be possible to remove the backrest if the levers have been located correctly. Lift up the skirt guards ensuring that the rear flap (A) passes around the backrest tube and fasten the Velcro panels together (see FIG 4).

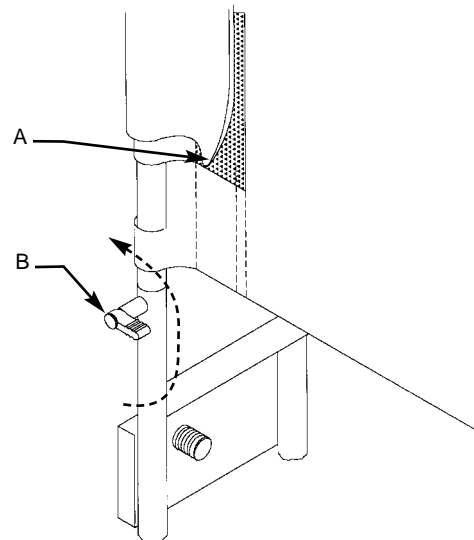

Figure 4

- 5 Fit the footrest hangers by locating each footrest hanger (A) in to the wheelchair frame socket (B) and rotate the footrest hanger until it locks into the hole at position (C). The locking pin (D) will lock the footrest hanger into position (see FIG 5).

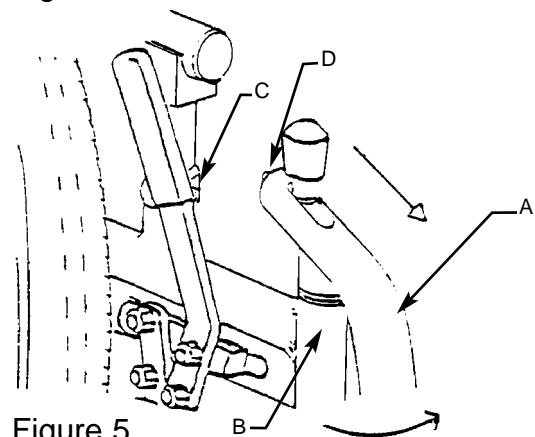
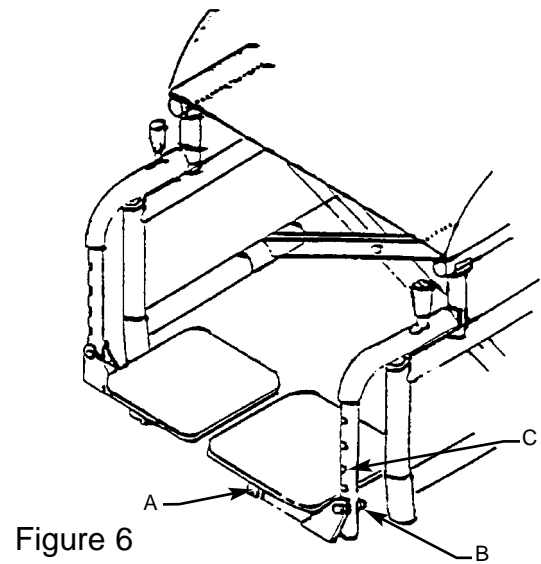

Figure 5

IMPORTANT

Keep fingers away from the frame socket to avoid trapping fingers.

- 6 Lower the footrest plates (A) into position. The footrest plates can be adjusted for height by removing the fasteners (B) and repositioning into the pre-drilled holes (C) (see FIG 6).



- 7 Anti-tip rollers are fitted to inhibit backwards tip and can be adjusted to give a choice of two angles.

To adjust the angle press both spring studs (A) and reposition to the pre-drilled holes in the tipping bar (B) (see FIG 7).

The rollers can be removed from operation by rotating the assembly upwards and locating the spring studs in the pre-drilled holes in the tipping bar.

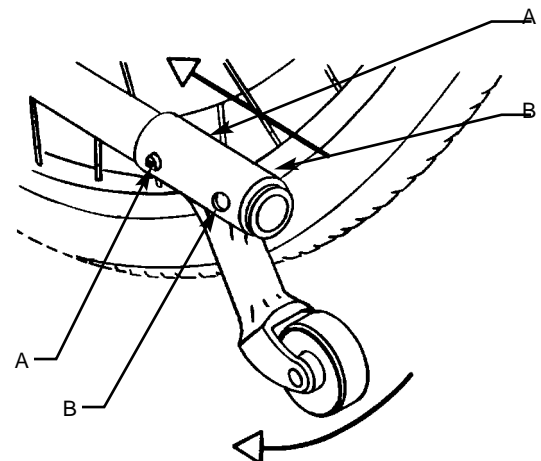

IMPORTANT

Always make sure that both anti-tipping rollers are correctly positioned before using the wheelchair.

- 8 The balance of the wheelchair can be adjusted by selecting from three wheel positions (see FIG 8).

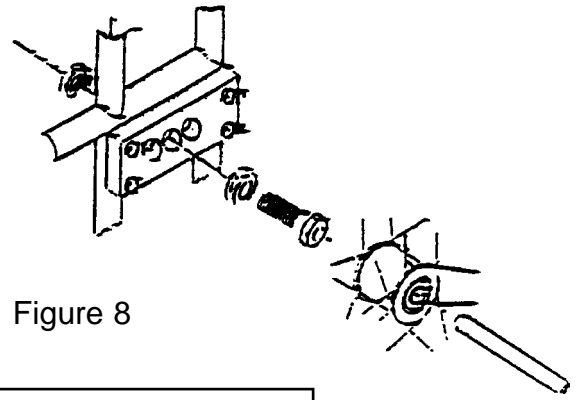

Figure 8

IMPORTANT

It is advisable that this procedure be carried out by your wheelchair supplier who should ensure that the driving characteristics meet your requirements.

- 9 The brakes will also need to be repositioned if you have selected an alternative wheel position (see FIG 9). Loosen the two socket head cap screws. Position the brake assembly on the wheelchair frame ensuring that the brake is effective. Finally tighten the two socket head cap screws in the clamp to 13.55-16.26 Nm (10-12 lbs/fit).

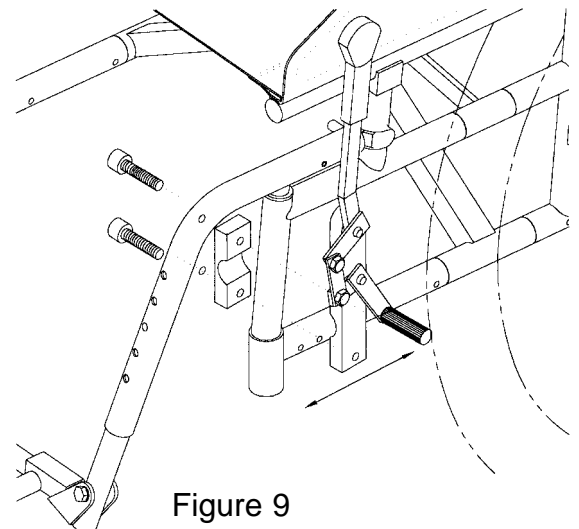

Figure 9

IMPORTANT

It is advisable that brake resetting is carried out by your wheelchair supplier. After resetting check the effectiveness of the brakes by sitting in the wheelchair with the brakes applied and attempt to propel the wheels. If the wheelchair moves, the brakes require further adjustment.

5. FOLDING THE MINI-METEOR WHEELCHAIR FOR STORAGE OR TRAVEL

- 1 Flip up each footplate (A). Slide each locking pin (B) and lift and rotate each footrest hanger (C) upwards to remove (see FIG 1).

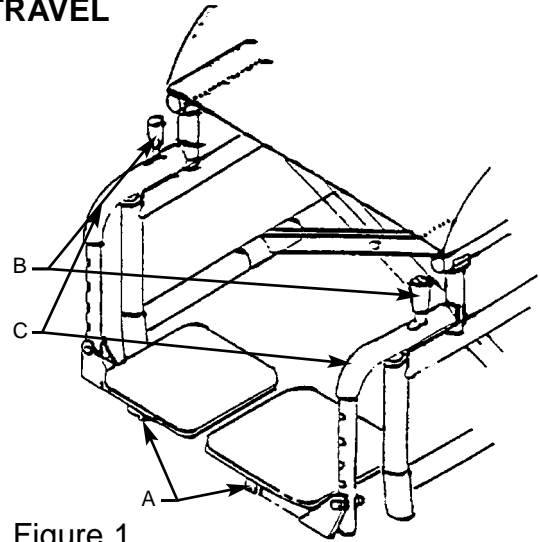

Figure 1

- 2 Release the Velcro flaps (A) retaining each skirt guard. Remove the backrest by rotating lever (B) on each side to point upwards and lift the back rest upwards until it becomes detached from the wheelchair (see FIG 2).

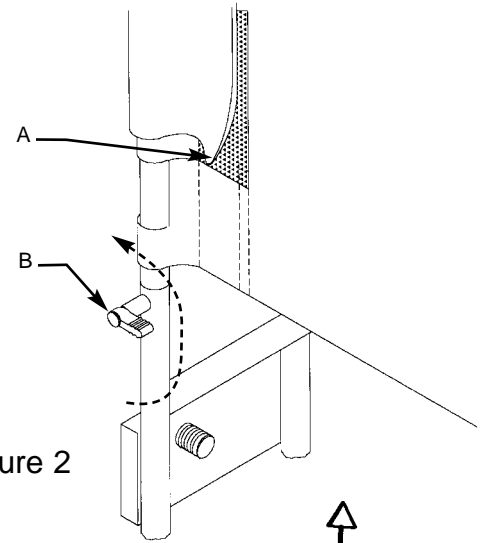

Figure 2

- 3 Standing to the side of the wheelchair place each hand under the front and back of the seat fabric. Lift upwards sharply to ensure the wheelchair fully folds (see FIG 3).

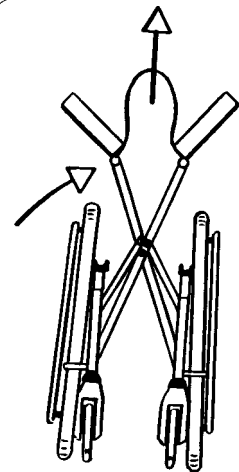

Figure 3

- 4 To remove the wheels, ensure the brake are not applied. With one hand hold the frame of the wheelchair and with the other hand hold the spokes surrounding the hub and fully depress the centre button. Pull the wheel away from the wheelchair and axle bush and release the centre button (see FIG 4).

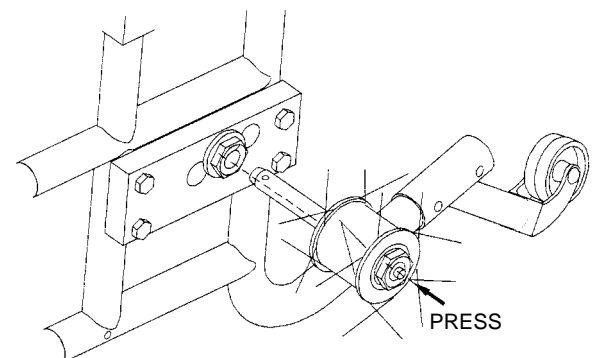

Figure 4

6. PUSH HANDLES

As an active user wheelchair, the Mini-Meteor is designed so that the user has a high degree of independence. Push handles are therefore not supplied as a standard feature. However, where a reasonable level of attendant control is required, push handles are available as an optional accessory from your wheelchair supplier.

To fit the push handles remove the end caps (A) from the backrest assembly (B) and insert the push handles (C) into the backrest assembly. Pass the set screw (D) through the backrest assembly and push handle. Attach the nut (E) and tighten until it is a snug fit against the backrest assembly (see FIG 1).

To remove the push handles, reverse the above procedures.

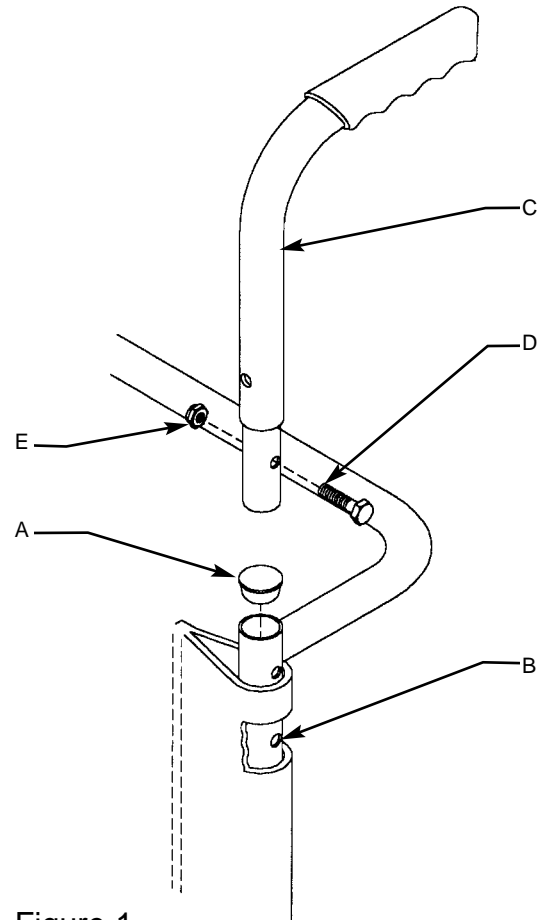

Figure 1

7. ATTENDANT PUSHING

IMPORTANT

It should be noted that the combined weight of the wheelchair and user can be quite considerable, so take great care when tipping backwards.

As an active user wheelchair for those requiring a high degree of manoeuvrability and independence, the Mini-Meteor is not intended for those users requiring a high degree of attendant control. However, depending upon the age, size and abilities of the child, attendant pushing and assistance may be required to a greater or lesser extent. The following notes are therefore relevant.

Attendants/assistants will require enough physical strength and agility to safely assist the user when getting in and out of the wheelchair.

Where possible, adequate space should be allowed as physical exertion in confined spaces can lead to strains and injury to both the user and attendant.

Attendants in control should be mentally mature and responsible.

The wheelchair occupant should be made comfortable by the attendant who should:

- a. Not walk too quickly when pushing the wheelchair.
- b. Make all moves slow and deliberate informing the occupant when he or she intends changing direction, preferably before the manoeuvre is commenced. Tipping the wheelchair or changing speed can cause occupant distress.
- c. Pay attention to the road surface, avoiding uneven or soft ground.
- d. When at a halt ensure that the occupant can see and communicate.

To assist the attendant push handles are available as an optional accessory. See Section 6 for fitting instructions.

It is safer to avoid kerbs wherever possible and use ramped kerbs or slopes. If this cannot be avoided, then adopt the procedures in Section 15.

8. GETTING IN AND OUT OF YOUR WHEELCHAIR

IMPORTANT

**Do not stand on the footrest.
Do not lean on one armrest only (if fitted).
Do take extra care on slippery/uneven surfaces and slopes.
Do remove any unnecessary obstructions.
Do apply the brakes.
Do fit the backrest as this prevents the wheelchair from folding.**

**There is a risk of the wheelchair tipping
if you are too far forward on the seat.**

**If you have not attempted these movements before, or your
medical condition does not allow you to support your body weight
comfortably, it is advised that an able bodied person be in
attendance to help and assist.**

9. GETTING IN THE WHEELCHAIR FROM THE FRONT

1. **Apply the brakes.**
2. Flip up the footplates and slide the footrest hanger locking pins and rotate the footrest assemblies to the side.
3. Stand close to the front edge of the seat with your back to the wheelchair and lower yourself into the wheelchair. Swing the footrest assemblies back to the front, lower the footplates and place your feet on it. **Beware** of catching your ankles or lower legs as you swing the footrests into position.

IMPORTANT

**Do not drop your body weight into the
wheelchair as this could cause it to tip
backwards.**

10. GETTING OUT OF YOUR WHEELCHAIR FROM THE FRONT TO A STANDING POSITION

- 1 **Apply the brakes.**
- 2 Flip up the footplates and slide the footrest hanger locking pins and rotate the footrest assemblies to the side.
- 3 Move forward on the seat and bend slightly forward to bring the body weight to the front of the seat. With both feet firmly on the ground and one foot back, push into the upright position.

11. SIDE TRANSFER TO A WHEELCHAIR

NOTE: This can only be done comfortably from a seating position that is at the same level and from a seat that does not have side arms which may obstruct movement.

- 1 Flip up the footplates, slide the footrest hanger locking pins and swing the footrest assemblies to the side.
- 2 Place the side of the wheelchair up against the seat you are on and **apply the brakes**. If an assistant is available, ask them to steady the wheelchair to prevent any movement that may take place.
- 3 **Beware** of the wheel and skirt guard and the upholstery securing screws during the transfer process. Sufficient support is needed so that you can clear these components as you transfer. You may find the use of a "transfer board" helpful.
- 4 When you are ready, reach out and place one hand on the seat as far away from you as you can reach and push downwards and sideways, transferring your weight from your seat to the wheelchair.
- 5 Swing the footrest assemblies into position by rotating them to the front of the wheelchair. **Beware** of catching your ankles or lower leg as you swing them into position. Fold down the footplates and place your feet on them.

IMPORTANT

Care should be taken to ensure that the user can support their own body weight when transferring.

12. SIDE TRANSFER FROM A WHEELCHAIR

NOTE: This can only be done comfortably to a seating position that is at the same level and to a seat that does not have side arms which may obstruct movement.

- 1 Flip up the footplates, slide the footrest hanger locking pin and swing the footrest assembly to the side.
- 2 Place the side of the wheelchair up against the seat you want to sit on and **apply the brakes**. If an assistant is available, ask them to steady the wheelchair to prevent any movement that may take place. You may find the use of a "transfer board" helpful.
- 3 Place one hand on the seat rail and place the other hand on the seat or surface that you are transferring to, ensuring it is stable.
- 4 Move forwards in the wheelchair and, leaning slightly forwards, push upwards and slide sideways.

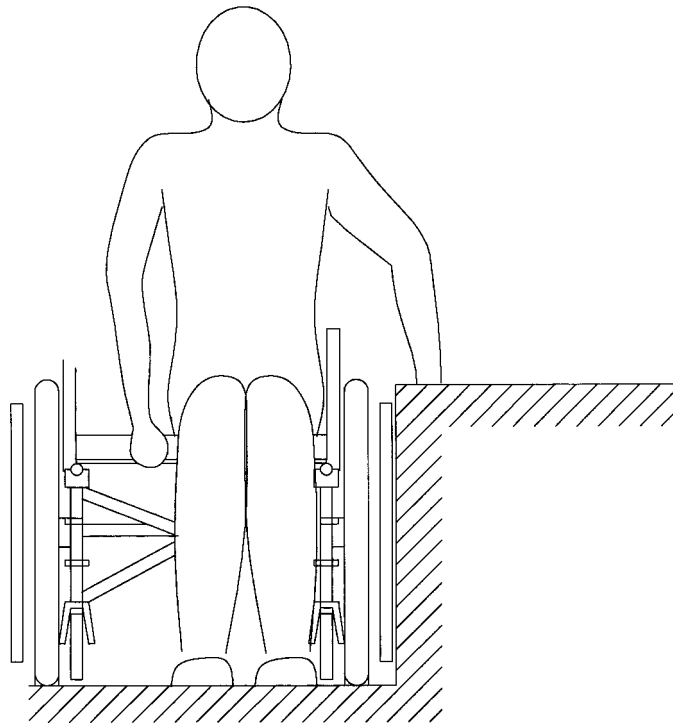

IMPORTANT

Care should be taken to ensure that the user can support their own body weight when transferring.

13. USING YOUR WHEELCHAIR : DO'S AND DON'TS

Moving forward and backwards is achieved by grasping both handrims and rotating in the required direction.

Turning left and right is achieved by holding the wheel stationary in the direction of travel whilst rotating the opposite wheel in the forward motion.

Braking of the wheelchair can be achieved by gripping the handrims to slow rotation. Be aware that high speeds may cause friction burns. Gloves may be advisable.

DO obtain training or assistance before attempting to kerb climb or descend.

DO ensure an attendant is present when balancing the wheelchair on its rear wheels until you are fully proficient in kerb ascending and descending.

DO ensure anti-tip rollers are fitted correctly.

DO take care negotiating inclines, uneven, soft or slippery surfaces, as the risk of tipping over is increased.

DO be aware of the surface temperature of all the wheelchair parts in hot and cold weather.

DO be aware that erratic control can cause injury to the user and other people.

DO be aware that effectiveness of the brakes may be reduced if the tyres are wet, muddy or greasy.

DO observe the Highway Code.

DO avoid soft ground.

DO keep clothes, rugs, covers etc. clear of the wheels.

DO fit a waist safety belt for additional security.

DO be aware that move pavements slope slightly towards the kerb and the wheelchair may tend to pull towards the road.

DO fit push handles when attendant pushing for prolonged periods of time.

DO use two hands for pushing.

DO ensure that the wheelchair is hygienically clean and suitable for multi-user use, if applicable.

DO NOT use the wheelchair without footrests, as feet may become trapped underneath.

DO NOT use the wheelchair if the tyres are not inflated to the correct pressure, as this may render the brakes ineffective.

DO NOT turn quickly as this may cause the wheelchair to tip.

DO NOT carry heavy objects/passengers, as this may lead to instability.

DO NOT lift the wheelchair using the armrests or footrests - always use the main frame.

DO NOT trap fingers between the brake pad and the tyre.

DO NOT use the wheelchair while under the influence of drugs or alcohol.

DO NOT force the wheelchair forward if it becomes stuck.

DO NOT stand on the footrests of the wheelchair under any circumstances.

14. ASCENDING AND DESCENDING SLOPES SAFELY

IMPORTANT

Movement of the occupant could cause the wheelchair to tip on a slope.

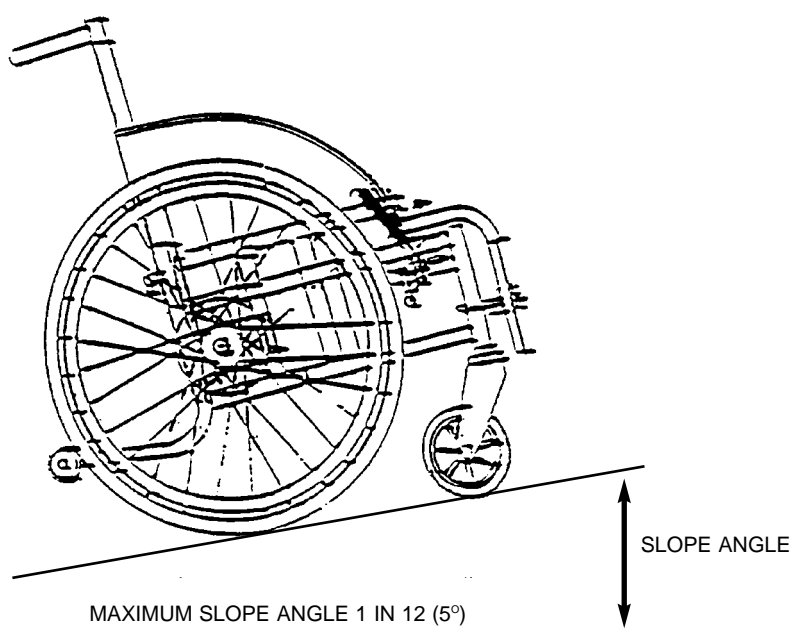

The Mini-Meteor wheelchair is designed with a short wheelbase in order to make it more manoeuvrable and so that it can be balanced by the user on its rear wheels. This makes it more liable to tip back when ascending slopes.

The Mini-Meteor wheelchair remains stable when ascending a slope of 1 in 12 (5°). **Beware** if you feel the wheelchair becoming unstable, do not proceed.

When descending, a slow speed should be maintained by gripping the handrims firmly. Excessive speed could cause friction burns on the hands. On steep slopes, care should be taken not to slip out of the wheelchair.

Wherever possible, an attendant should provide assistance by pushing (if ascending) or restraining (if descending) whilst the occupant controls the wheels.

Attendants should have sufficient strength to control the wheelchair and occupant when negotiating inclines, kerbs or steps.

15. ASCENDING AND DESCENDING KERBS INDEPENDENTLY

It is safer to avoid kerbs wherever possible and use ramped kerbs or slopes. It is possible to take yourself up and down kerbs unaided particularly as the Mini-Meteor has been designed for active users wishing to have a high degree of independence. Users can quickly become proficient and fully independent in getting up and down kerbs providing they have practised and developed a safe technique that is suited to their abilities.

It may be necessary for the user to obtain training advice ensuring that those more difficult manoeuvres are conducted safely and efficiently.

We recommend the following as being sources of training information:

Disability Information Service

Disablement Service Centre

Banstead Mobility
Damson Way
Fountain Drive
Queen Marys Avenue
Carshalton
Surrey SM5 4NR
Telephone: 0181 770 1151

Royal Association for Disability and Rehabilitation
Unit 12
City Forum
250 City Road
London EC1V 8AF
Telephone: 0171 250 3222

Disabled Living Foundation
380-384 Harrow Road
London W9 2HU
Telephone: 0171 289 6111

IMPORTANT

Movement of the occupant could cause the wheelchair to tip on kerbs and steps.

GOING UP A KERB FORWARDS WITH AN ATTENDANT

For those users who are unable to independently climb kerbs an attendant should provide assistance by pushing using the backrest pushing bar if ascending (or restraining if descending) whilst the occupant controls the wheels and brake operations.

- 1 Make sure the occupant's feet are on the footplates and will not slip off.
- 2 Release both brakes.
- 3 Place both hands firmly on the push handles. **Make sure the handgrips are secure and cannot be pulled off.**
- 4 Ensure that the anti-tip rollers are correctly positioned (see Section 4 FIG 7) and put one foot on the tipping lever at the back of the wheelchair (see diagrams below). Tell the wheelchair occupant you are about to tilt backwards.
- 5 Pull back with both hands and push down and forwards with the foot. This will bring the wheelchair onto the back wheels. **If it is tilted too far back, it will be heavy to hold and the person in the wheelchair will feel unsafe. Do not let the castors rise more than 4" (10cm) off the ground.**
- 6 Push the wheelchair forwards. The user can assist the attendant by propelling the rear wheels. Gently lower the front castors on to the pavement, and push the back wheels upwards over the kerb.

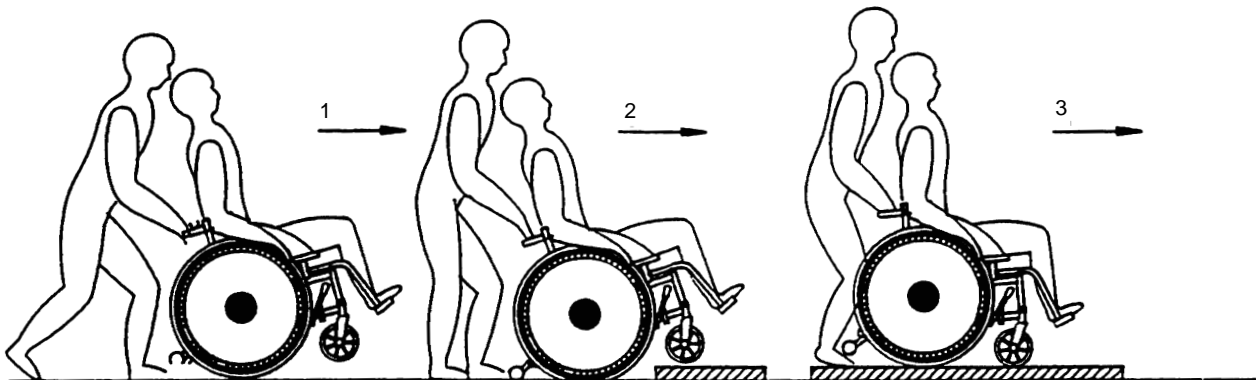

GOING UP A KERB BACKWARDS WITH AN ATTENDANT

IMPORTANT

This is a difficult method, requiring more strength and should only be attempted with a light person in the wheelchair.

- 1 Turn the wheelchair around so that the back wheels are resting against the kerb.
- 2 Ensure that the anti-tip rollers are correctly positioned (see Section 4 FIG 7).
- 3 Pull back on the push bar and push downwards to tilt the wheelchair so that the front castors are off the ground. The proximity of the kerb will prevent the use of the tipping levers as previously described.
- 4 Pull the tilted wheelchair up the kerb and on to the pavement. The wheelchair user may wish to self-propel to assist the attendant.
- 5 Continue pulling until the castors are over the pavement. Gently lower the castors to the ground.

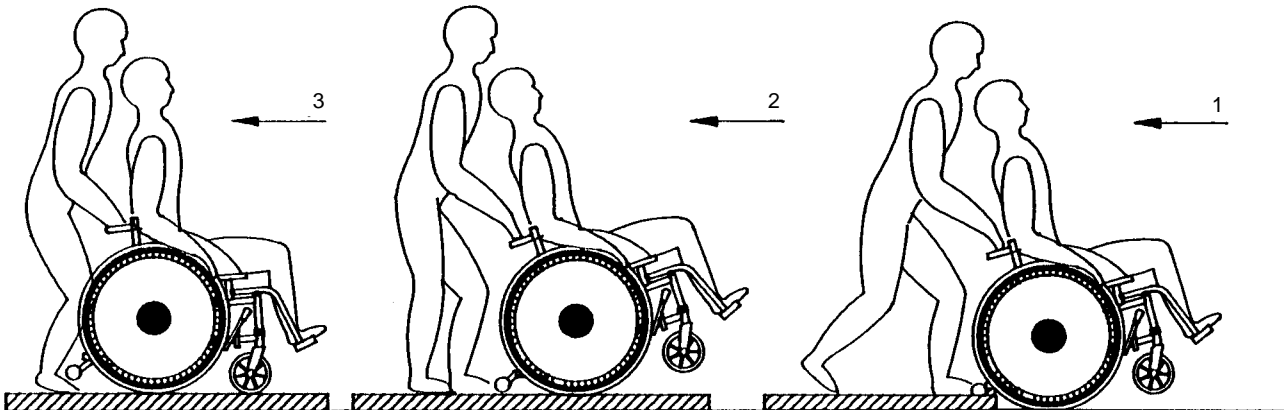

GOING DOWN A KERB BACKWARDS WITH AN ATTENDANT

This is the easiest and smoothest method and is the reverse sequence to that described in **GOING UP A KERB FORWARDS**. As it requires the attendant to step off the kerb backwards into the road **exercise extreme caution**.

- 1 Back the wheelchair to the edge of the kerb.
- 2 Ensure that the anti-tip rollers are correctly positioned (see Section 4 FIG 7).
- 3 Use the push bar to pull the rear wheels down onto the road.
- 4 Tilt the wheelchair backwards as previously described and push the tilted wheelchair further into the road. The user may wish to restrain the handrim to assist the attendant.
- 5 When the footrests are clear of the kerb, lower the front castors on to the road.

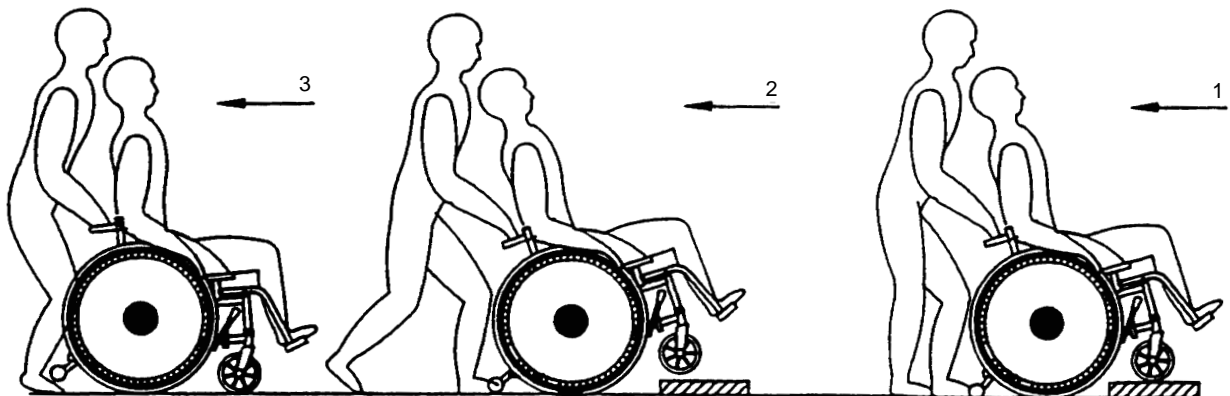

GOING DOWN A KERB FORWARDS WITH AN ATTENDANT

This method has the advantage that you can see the traffic more easily. The disadvantages are that it is harder physical work and it is not easy to lower the wheelchair gently without jarring the person in the wheelchair.

- 1 Position the wheelchair so that the front castors are close to the edge of the kerb and check that the road is clear.
- 2 Ensure that the anti-tip rollers are correctly positioned (see Section 4 FIG 7).
- 3 Pull back on the push bar, gripping it firmly, and at the same time push downwards and forwards with the foot on the tipping lever to balance the wheelchair on its back wheels.
- 4 The person in the wheelchair may be able to help by using the handrims to steady the wheelchair.
- 5 Move the wheelchair forwards and then gently lower the rear wheels down the kerb while supporting some of the wheelchair's weight yourself. Make sure that both wheels touch the ground at the same time because if not the wheelchair could tip over sideways.
- 6 Gently lower the front castors.
- 7 Check that the road is still clear before moving off.

IMPORTANT

Never tip the wheelchair forwards when going down a kerb. The person in the wheelchair might fall out.

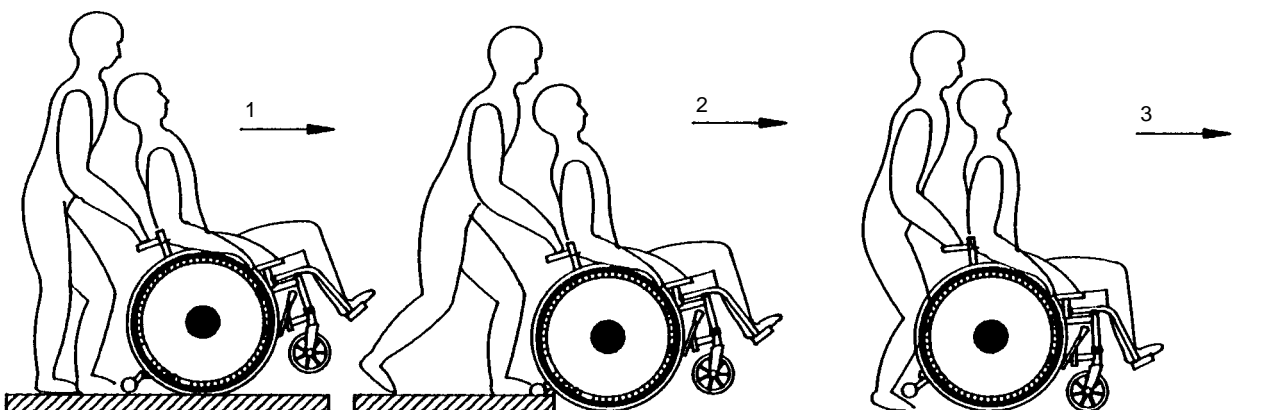

16. UNEVEN, SLIPPERY AND SOFT SURFACES

Care should be taken at all times. Maintain a slow speed, so that you can keep control. Note that grass may be soft and the wheels may sink, causing the wheelchair to tip. Any moisture or mud on the tyres may affect the proper operation of the parking brakes.

17. CARE AND MAINTENANCE OF YOUR MINI-METEOR WHEELCHAIR

Your Mini-Meteor wheelchair should require very little maintenance when used with care and discretion and will retain its appearance if looked after and cleaned in accordance with the following instructions.

Protection of your wheelchair during shipment or travel is dependent upon the type of journey envisaged, but attention should be given to protecting the more fragile items.

18. TYRE PRESSURE

IMPORTANT

Under no circumstances should garage powered airlines be used.

If your wheelchair is fitted with pneumatic tyres, a hand pump is provided. Tyres are best inflated by an assistant with a car type foot pump up to the recommended pressure of 50psi/340 Kilopascals (KPA). This pressure is also displayed on the wall of the tyre.

Pressures should be checked weekly, using a proprietary pressure gauge and a daily visual check made of the tyre condition. Things to look for are nails, sharp objects, etc. stuck in the tyre tread, splits, cracks or abrasions to the tyre wall, and a deflated tyre (this would indicate a puncture or leaking valve). Excessively worn or damaged tyres should be replaced without delay.

If the tyre does become deflated, or need replacing, contact your wheelchair supplier for assistance.

IMPORTANT

Brakes may not work if tyres are under-inflated.

19. CLEANING

The upholstery may be cleaned with warm water and mild soap. Never use a solvent of any type to clean your wheelchair.

The paintwork may be cleaned or polished with a car type polish. Wipe off any moisture after outdoor use and store your wheelchair in cool and dry conditions.

20. LUBRICATION

The castors on your wheelchair do not need any additional lubrication.

Each week a few drops of general purpose oil should be added to frame folding pivot points and brake pivots. Wipe away any excess oil to prevent dirt collection.

It is essential that the quick release axle and bush are kept lightly lubricated at all times to ensure ease of action. It is recommended that a silicon-based lubricant is used for this application or a water displacing lubricant, eg WD40.

21. MAINTENANCE SCHEDULE

IMPORTANT

It is advisable that professional servicing is carried out at six monthly intervals for a wheelchair in constant daily use.

For a wheelchair exposed to less usage, the weekly checks should be carried out every time the wheelchair is used.

DAILY CHECK:

- Handrim damage and security.
- Hand grips for secure attachment.
- Brake operation.
- Folding mechanism.
- Loose or bent spokes.

WEEKLY CHECK:

- Quick release wheel plunger mechanism operates smoothly without sticking.
- Quick release wheel and castor security.
- Seat and backrest upholstery/cushions for tears or damage.
- Push handles for security.
- Cross brace folding mechanism. Check that the pivot bolts are not loose.
- Tyre pressure and condition.
- Lubrication as above, Section 20.

22. GENERAL CHECKS TO BE CARRIED OUT AT MONTHLY INTERVALS

IMPORTANT

If any of the items listed below give cause for concern, consult your wheelchair supplier immediately.

Do not overtighten upholstery screws as this can damage the upholstery.

It is advisable that professional servicing is carried out at six monthly intervals for a wheelchair in constant daily use.

- 1 Open the wheelchair. All movements should be free throughout the folding range and should not bind or seize whilst operating.
- 2 All pivot bolts should be secure with no sign of nuts or bolts working loose, but they must be free enough to allow the component parts to move whilst operating.
- 3 Examine the seat and backrest upholstery for wear or damage. Examine the retaining screws for tightness. Any that are protruding or loose should be tightened with a Pozidrive (cross point) screwdriver.
- 4 Examine the brakes for wear, damage or misalignment. Ensure that both brakes prevent the rear wheels turning, when fully applied and the tyres are inflated to the correct pressure. If not, refer to your wheelchair supplier for adjustment.
- 5 Check the castors for free rotation of the castor wheel and swivel assembly. Look for looseness or binding.
- 6 Check the rear wheels for free and easy rotation. Check the rims for any buckling or distortion and check for any spokes that may be loose or need tightening. Check that the quick release wheels remove and refit securely, and that the plunger mechanism operates smoothly without sticking.
- 7 Check the push handles for security and the handgrips for wear or damage and that they are securely attached to the push handles.
- 8 Examine the footrest hangers for effective locking when fully forward.

23. MINI-METEOR FACTORY FITTED OPTIONS

Wide Profile Castors. Increases stability on rough ground.

Backrest Extension (Choice). An upholstered extension offering increased back support.

Frame Colour Choice. To meet customer requirements a wide choice of colours is available in a durable powder coated finish.

Seat Height/Width/Depth Variation. To ensure that our product meets the needs of growing children, a wide range of variations is available.

Choice of Upholstery. A range of coloured upholstery is available to meet our customers' requirements.

Armrest Assemblies. Of tubular construction fitted with foam flame retardant pads, these offer a high degree of comfort for the wheelchair user.

Puncture Proof Tyres. An invaluable option for those people who cannot afford the risk and cost associated with punctures.

24. MINI-METEOR WHEELCHAIR ACCESSORIES

Cushions. A choice of colour co-ordinated backrest and seat cushions is available in either flat or contoured shapes. They enhance the wheelchair's appearance as well as offering a high degree of comfort.

Waist Belt. A safety belt fitted with quick release fastener offering user and attendant peace of mind.

Calf Strap. Offers support to the calf for users with impaired leg control.

Lightweight Carry Bag. A useful accessory when travelling, this bag ensures that all the wheelchair components remain together without fear of loss.

Crutch/Walking Stick Holder. Positioned at the rear of the wheelchair, this option enables walking sticks and crutches to be carried conveniently.

Push Handles. Enables the attendant to push the wheelchair more easily. A choice of height alternatives is available.

25. SERVICE HISTORY

As it is important to keep a documented record of service and repairs to your wheelchair, this section of your manual should be completed by your wheelchair supplier with details of any work carried out. This information will also be helpful to your supplier, and to you, should you decide to sell or exchange your wheelchair. Please ensure that this manual accompanies your wheelchair whenever a service is required (recommended every 6 months) or any work is carried out.

Service Interval	Details of work carried out	Repairer's stamp
6 Months		
		Date Initial

Service Interval	Details of work carried out	Repairer's stamp
6 Months		
		Date Initial

Service Interval	Details of work carried out	Repairer's stamp
6 Months		
		Date Initial

Service Interval	Details of work carried out	Repairer's stamp
6 Months		
		Date Initial

Service Interval	Details of work carried out	Repairer's stamp
6 Months		
		Date Initial

Service Interval	Details of work carried out	Repairer's stamp
6 Months		
		Date Initial

Service Interval	Details of work carried out	Repairer's stamp
6 Months		
		Date Initial

Service Interval	Details of work carried out	Repairer's stamp
6 Months		
		Date Initial

Service Interval	Details of work carried out	Repairer's stamp
6 Months		
		Date Initial

Service Interval	Details of work carried out	Repairer's stamp
6 Months		
		Date Initial



26. WARRANTY

In the unlikely event of your needing it, R J Mobility Limited's warranty is:

- 1 Defective parts and items of faulty workmanship will be replaced or repaired free of charge for the first 12 months following delivery (24 months in the case of the crossbrace and frame).
- 2 This warranty does not apply to fair wear and tear, or where deterioration results from neglect, carelessness, accident, misuse, unauthorised modification or the fitting of parts not supplied by R J Mobility Limited.

Please contact the supplier of your wheelchair to arrange warranty repairs.
This does not affect your statutory rights.