

Strida - Personal Tips, and comments

by Mark Sanders, *Version3b*, Nov. '07 (these will be continuously updated)

Many of these tips are covered in the Strida user manual, and Strida Website. I recommend that the safety tips here should be emphasised to end users.

A) Safety Tips ..

1. As Steedman so eloquently says, on the website....

- wear a helmet: it's not fashionable, but neither is brain damage.
- as on any bike avoid flared trousers while riding your strida. these can get caught in the belt.
- no wheelies! no stunts!

2. Although Strida is one of the most maintenance free bikes, as any mechanical device: Do check and tighten loose screws (page 17), and any other parts that may have been accidentally damaged.

check these bolts every month **and dont let these unscrew**

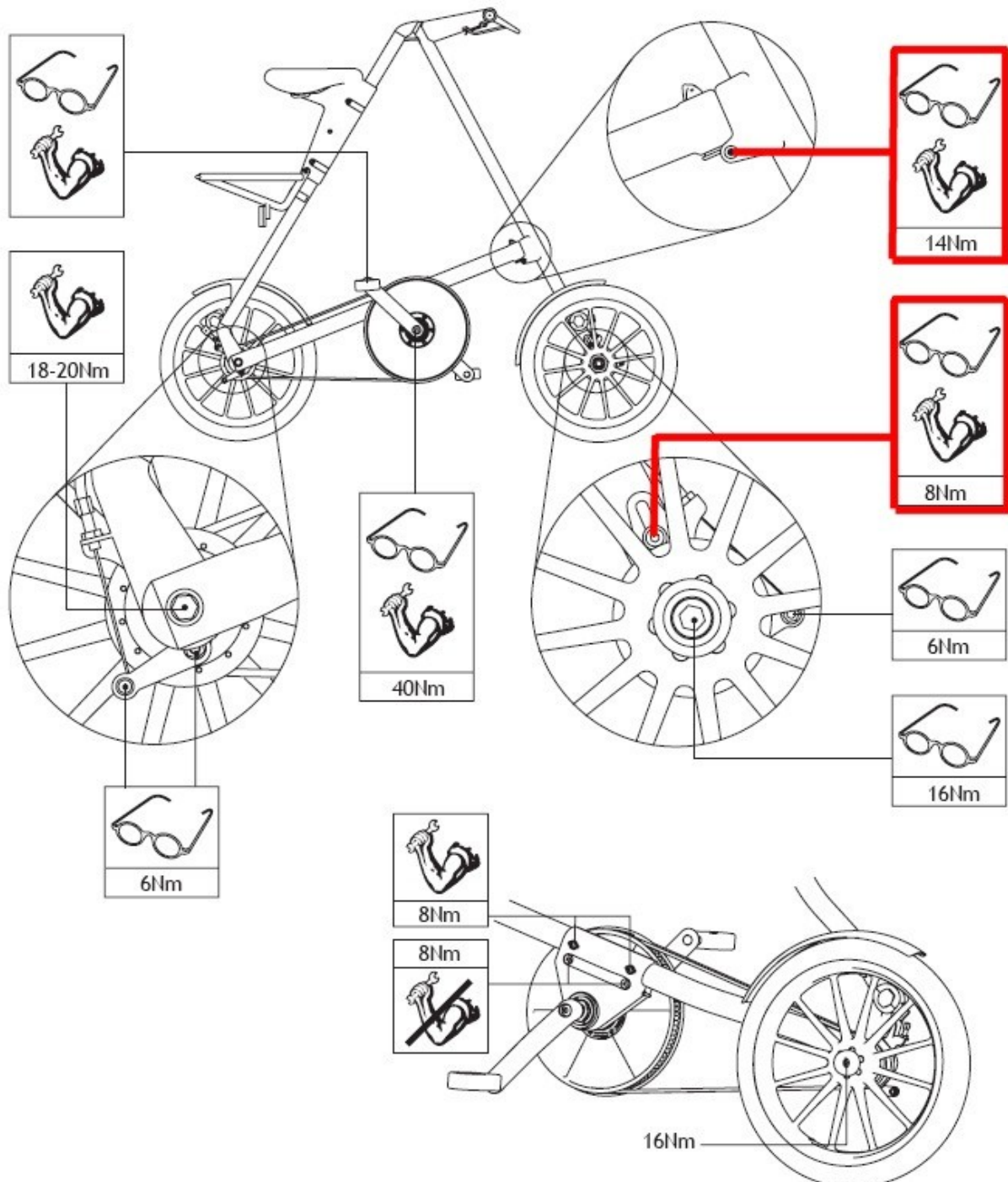

3.

Tighten TOP & Bottom Seat Screws very TIGHT to avoid 'Bum Skirm' and broken pins !

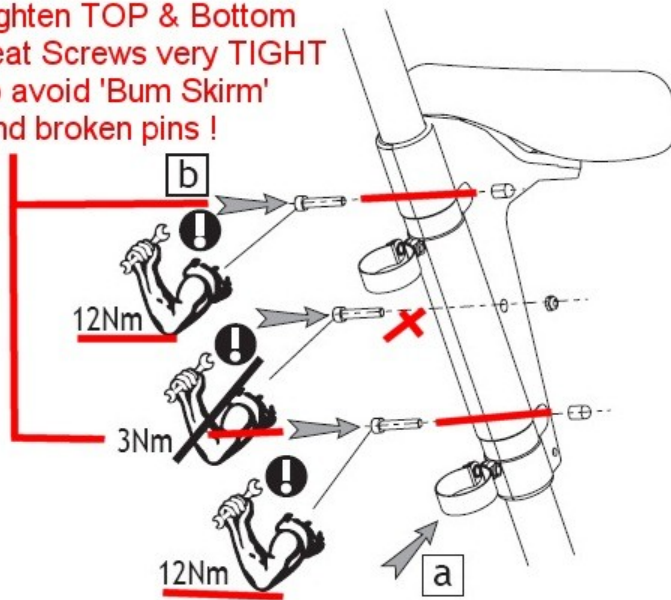

4. When unclipped, **Never** let the Front tube run forward or hyper-extend, as below – as this ultimately damages the top ball socket. (this plastic part is designed to let the ball 'pop-out' in this situation, to avoid breaking the ball off).

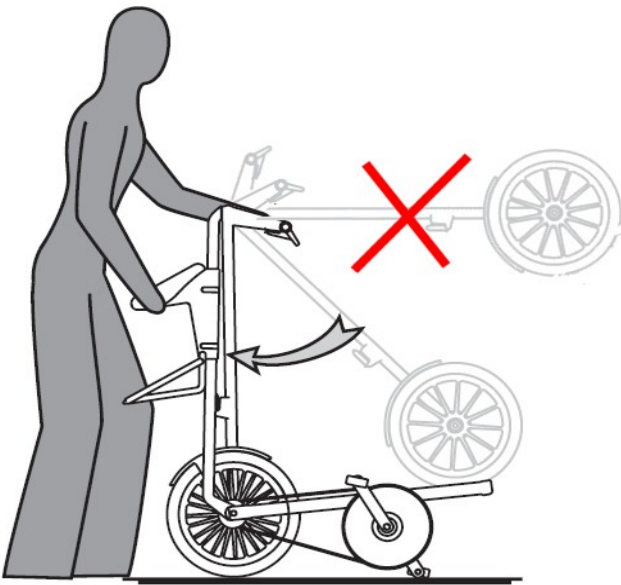

But if this happens always replace the 3 plastic parts, with new parts

If damaged replace all 3 parts

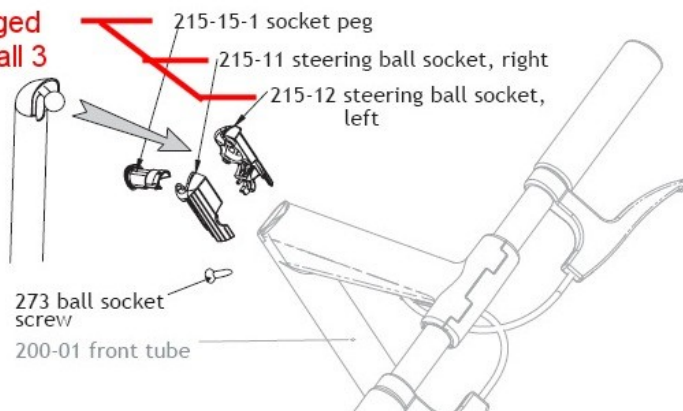

(except in emergencies see tip 3 below).

4. Instructions for fitting tyres to plastic wheels

1. Always install a new (or flat) tyre/ tube *with the bike on its side* ((ie so that the wheels are HORIZONTAL))
2. Align the tyre to be completely concentric with the wheel (ie equal gap all round).
3. Then pump up and make sure the tyre stays concentric.

Always do the above when tyres are flat - But it is not necessary when just increasing tyre pressure.

Other points for Plastic wheels

1. Never use more than 65psi (4.5bar) pressure on Plastic wheels.
(warning: If pumped up to 65psi in cold, and then bike is left out in the sun - the pressure can go up VERY high - ie 80Psi + and has been known to 'pop' off – which is VERY loud – sounds like a gun shot !!)
2. The Plastic wheel is normally very strong and abuse resistant, but if someone has pumped up a tyre (or let a tyre expand in heat) to about 100psi (6.8bar) then the rim could be permanently stretched, and may need renewing.

B) General Tips

1. **Push off**, when setting off, rather than trying to just stand on the pedals. For simplicity (design aim) Strida is single speed, (now fashionable amongst urban riders). This means the gear is optimised for most *riding* situations, this makes it slightly high for setting off – but with a small push off this is not a problem.

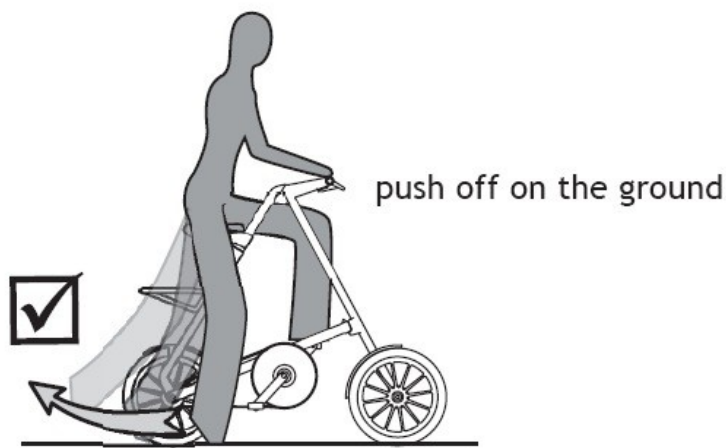

2. Tall people - put the seat high, and back

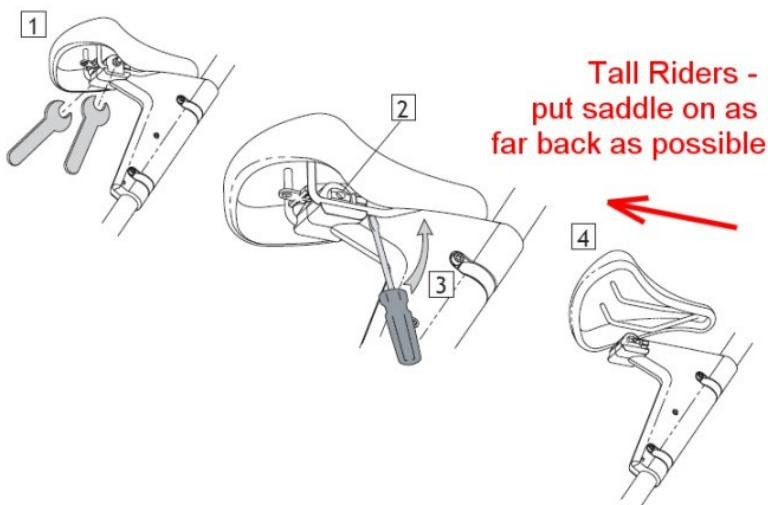

Marks (1.9m+) *well travelled* own bike



3. Emergency replacement of the top ball (plastic parts should be properly replaced asap, as A4 above)

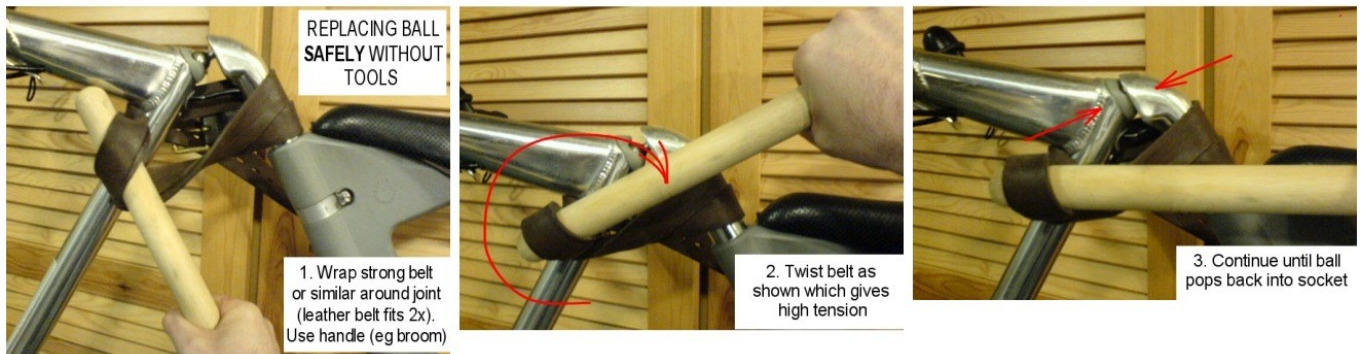

4. If magnet catch on rear wheel rattles, unscrew and put a small rubber o'ring between the plastic washers.

5. If the brake cables rattle inside the front and rear tubes, either push more of the cable into the tube (from top or bottom) to push cable against the inside of the tube, ..or.. pull more cable *out* of the tube – to pull the cable away from the inside of the tube.

6. Keep tyre pressures high as possible ie 50-60psi for Plastic wheels (and higher for metal wheels). This has THE biggest effect on overall feel, speed and efficiency.

7. Keep belt tension as low as you can tolerate ! This improves efficiency and reduces wear. On bikes without rear belt snubber, I run the belt tension so the weight of my arm (average) presses the belt to approx 2-5mm of the bottom tube – this means that in the wet setting off / up hills the belt can occasionally 'pop' over a tooth. On bikes with a snubber the belt can have same (low) tension and belt will not 'pop'.

8. On bikes with a rear belt Snubber; the snubber bearing should have a small gap, (approx 0.25mm) between it and the belt. So the bearing does not continuously turn with the belt (occasionally high spots on the belt may turn the bearing momentarily – which is OK). The snubber works by ONLY stopping the belt rising out of the teeth under *high loads*, most of the time it is clear of the belt. To adjust the snubber gap, carefully slacken the lock nut and fixing bolt (v tight), and then the Bearing position can be adjusted, then re-tighten - Also see strida.com web site for more info.

9. For quick folds (4 sec or less !) just fold the frame and leave the bars and pedals out, then only fold the bars in 'on the move' . I prefer the small VP220 non-folding pedals, narrow, rounded, stiff and no hassle !

10. For min space / weight use a back pack or shoulder bag instead of the carrier, BUT you lose the neat rear stand.

11. When folded and wheeling along hold the bike more vertically, even with the saddle, to reduce weight on the arms. There is a good handhold at the front of the saddle.

12. When wheeling, forward is normally best, but as long as pedals clear, the bike can also be dragged along 'backwards' (eg drag on RHS with LH bars (now on rh side) for a handle. Try also Drag behind by holding onto front of saddle. We are all different sizes, so experiment until you find the most comfortable position... we all have saddles at different heights !

13 Use a cheap golf equipment carrying bags as low cost, wheeled airline bags.

14 getting rid of squeaks and noises

Damn Rodents caught in the belt ? 🐭 here are a few suggestions..

1. The side of the belt can squeak against the sides of both the front pulley and the rear pulley 'flanges' (or side belt retainers) .. this is because although the tooth face of the belt has no rubbery material, the sides do ... and we all know what happens with rubber against a smooth surface :-)

to check this apply water to the belt (as its temporary, unlike oil) and see if that stops the squeak. ... if it does there is a choice ..

a) put up with it .. knowing its just the belt or

b) carefully applying some candle wax to ONLY the sides of the belt NOT the teeth.

2. The BB moulding can sometimes squeak a bit .. I think some have more rodent reinforced, 'squeaky' plastic than others.. I have found a solution is to strip the BB down (carefully) clean the insides of the moulding and the tube .. can get debris etc. especially if used in bad weather and off road. Then re-assemble .. carefully put a small amount of grease or better - candle wax where the plastic meets its self BUT NOT where the plastic touches the tube.

Then re assemble bolts .. tight but not to breaking point. the M6 top screws thro the tube can be tightened v tight by using a 10mm thin spanner in gap next to pulley.

3. Same instructions with seat mouldings .. they can squeak. Also make sure clamps are really tight (this also avoids 'squirmy bum syndrome' :-)).

Thats about it ... other possible strida noises include

Brake cables rattling in tubes (push them in to stop this)

Debris in brakes (take off and clean)

Loose bearings in wheels (take out and use bearing fit [glue] or self adhesive masking tape.)

Loose BB bearings (adjust)

Loose BB bearing outer shells in mouldings (take out and use bearing fit [glue] or self adhesive masking tape.)

Freewheel noises (is belt too tight ?) .. or use squirt in aerosol grease (motorcycle spray on chain lube).

The only other thing if you catch the little blighters is to put them on on squewers over the BBQ

C) Strida Myths

Myth 1. Belt drives have poor efficiency

I recently met the guy from Gate.coms who developed the belt for Strida (and car camshafts, and motor cycles), he reminded me that belt toothed belt drives (like strida's) are used to replace chain and V belt drives as part of government energy efficiency schemes ! He explained that Motor cycle manufactures (like Harley-Davidson and Kawasaki, have been using belts for years for the best life long efficiency and to be clean and maintenance free (chain wear on a motor bike is a real pain, and uses a lot of energy).

There are more losses by using hub gears, and tensioners / idlers on bike chain drives than when using a belt. Allow the chain to get dirty, or use a non-aligned derailleur gear ratio and the belt wins hands down on efficiency.

Myth 2. Strida is slow cannot be used for long distances.

Although Strida is designed primarily for urban use (see next myth), and choosing one specifically for touring might be questionable Stridas have been used to ride the length of New Zealand, and the length of the Nile. What is a much bigger factor than the bike itself is the 'engine' who is 'driving' it. I am lucky enough to test a wide range of new folding bikes (my own and other brands) including bikes with 120psi 700c racing wheel/tyres, and along my test routes (which include steep hills, tracks and urban routes) the only places where Strida is noticeably slower is downhill where its single speed just runs out of revs, on the flat and even up all but the very steepest hills Strida is within seconds of other bikes (and often faster than some). The Stiff Strida frame, especially in latest form is actually very responsive and climbs hills well, in the saddle. The key factor is the engine, in this case ME !! I am sure fitter cyclists will be faster, this would apply to all the bikes.

As soon as Strida gets into the environment it was designed for ie *mixed mode urban*; trains, cars and walking along corridors etc., it is usually THE fastest of all. The 10-20 seconds advantage it has in folding / unfolding usually obliterates speed advantages of other bikes, if any, due to gears. Throw in a few long corridors / shops where other folding bikes have to be carried and Strida wins hands down !.

Myth 3. Strida has poor ergonomics.

For racing, and where riding at 9/10th or more is normal, then getting the best aerodynamics and power stroke is important to extract the last 1/10 seconds. The snag is the same setup advice is passed down (as hearsay eg on cycling forums etc.) as 'the norm' for *all* bicycle use – which is total rubbish ! In town, good visibility from a close handle bar upright riding position is more important than lying flat (with bended back and straining neck) for aerodynamics. Hence the classic dutch

BICYCLING POSTURE - RACING, ADULT MALE

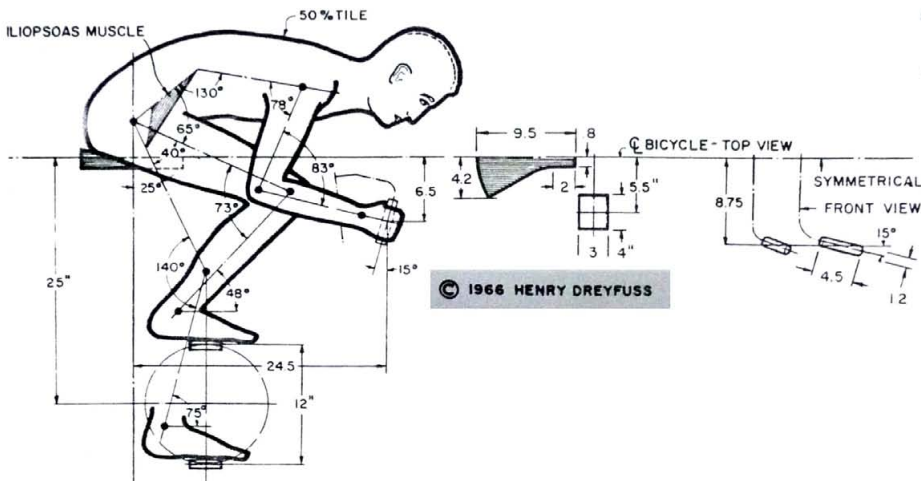

BICYCLING POSTURE - CRUISING, ADULT MALE

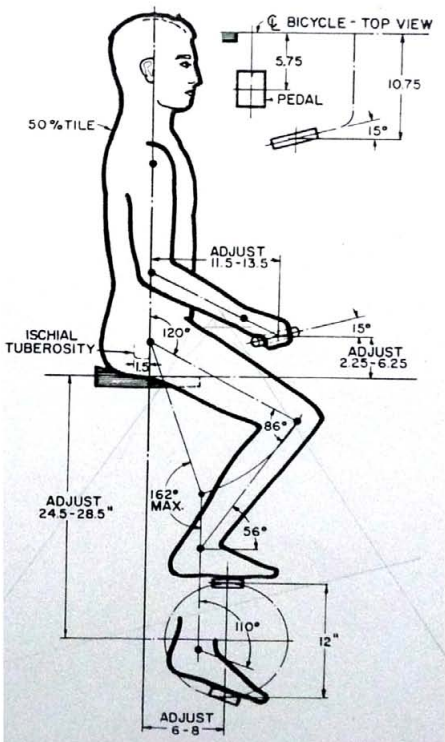

continental bikes. Many folding bikes aim to please the 'racing cyclist/enthusiast' some are even designed by racers – but is this appropriate for urban use ?

I felt not, and during the stringent masters degree program from which Strida was evolved, I met up with a top UK ergonomist. He helped me to do tests (with a fully adjustable test rig) and understand the riding habits of potential users: mainly urban, multi-model commuters in the 5 to 95%ile range, from this work the upright riding position for favoured, and the bent arms that taller riders (like me) get from being close to the bars does not matter, as arms are bent when riding.

Myth 4. Strida has poor handling.

Originally the ergonomic test rigs were also used to adjust the steering axis, trail etc. that goes into giving a bike its handling characteristics. Also a lot of cycling books and handling theories were studied. For the 1st Stridas (eg Strida 1's), I followed the traditional 'handling theories', about what makes a bike handle well – and the handling was OK, but NOT perfect, so the myth was partially true back then. At the time I put this mismatch between the traditional wisdom of bike steering geometry and the actual 'feel' of the early bikes down to the short wheel base.

When Steedman bought the company he was keen to perfect the Strida. And he wanted to improve its handling, so he consulted all the 'experts' in the industry and they all came up with various theories about what would improve the handling – most suggested various angles and tweaks based on traditional theories, and most were wrong !! – We had a special fully adjustable test rig, and so could try out the theories and other settings. This was harder than expected because of the lack of 'Strida virgins' ... ie the human soon learns to adapt, and so familiarity with the bikes handling soon spoiled objectivity. In the end we changed 2 key factors: 1. we added ball bearings to the main loadbearing (lower) joint, 2. We used the geometry settings from the rig most preferred by 'strida virgins'. The steering geometry of a Strida (from Strida 2.5) is now quite different from the theories, but it works ! For a bike with such a short wheelbase the handling is now really good, a well balanced rider can ride hands off (don't try this at home folks !).

Myth 5. Strida is dangerous on impact, especially to the male species

Unfortunately, I have tested this myth several times, and thankfully remain intact ! (again 'please dont try this at home'). Last time was when it was dark, and I didn't see a very high kerb (10" / 25cm). Another time I missed off the screw stopping front drum brake rotation (see A2 above), on a prototype. What happens in these situations is, just like on a motor bike - the bike pivots about the (stopped) front wheel and catapults the rider UP. When this has happened to me, I landed on the ground (luckily with minor scratches), and then the bike landed on top of me - good job its light !

Myth 6. Strida is fragile

My Stridas regularly go through the checked luggage system at airports, some time in an unpadded bag and sometimes 'naked' the only precaution is I wrap an elastic bungie around the folded frame. Ok, I have several Stridas, and so can afford to take less care than owners. But with a some scratch protection (eg in a bag, and with say pipe insulation to protect pristine tubes), there is no reason why any user shouldn't do the same.

The best Strida for this type of abuse is the Strida3 with GF nylon wheels, as these, along with hub brakes can withstand a lot of abuse which may damage conventionally spoked wheels, and brakes.

D) More FAQ's

1. Snubbers

Question: "I Have a friend who is a good mechanical engineer, & he wonders why the "snubber" bearing is placed effectively at the centre of the rear sprocket rather than at the point where the belt starts to wrap around the sprocket?"

Answer: This is a good question. The mechanical engineer is *theoretically* correct - the ideal theoretical position for the snubber would be at the at the start of the belt wrap. *But* this would restrict the bottom tube movement when folding, (ie when lowering bottom tube to the ground). **Also** I did some testing and found the position of the snubber around the rear pulley made marginal difference, to the effectiveness of the snubber - I think this is because when belt teeth jump, they ALL rise up over the pulley teeth *together*, so a snubber position is less critical than theory suggests. It certainly works 100% on Strida :-)

Interesting factoids ..

Strida (and car cam shaft belts) are reinforced with Kevlar for super strength.

However kevlar is a weird material with a reverse co-efficient of thermal expansion (ie unlike most materials, it gets longer as it gets colder and vice versa).

In the early days of the Strida I didn't realise this - so in the winter when I was testing early belt systems I'd set up

the tension perfectly (in the warm workshop), BUT when testing it seemed to get loose, back in workshop it was OK It took a lot of head scratching to work this out :-).

Lotus cars 1st introduced snubber in the 1970's when they were developing their 1st belt drive cam shaft engines ... which used to jump in cold Canadian mornings - and wreck the engines ... but their snubber where crude - did not have bearings and just forced the belt to stay engaged. Snubbers, especially with bearings are very neat because they do not touch the belt in normal use, only when the belt is about to slip - they allow the belt tension to be reduced and so improve efficiency and wear.

V3b, Mark Sanders, Nov 2007

Fitting Fenders with 18" wheels on a STRiDA

Use a washer over the top mudguard screw so that the screws clamp at the bottom of the mudguard fixing slots (rather than at the top, as normal). Please see picture.

I then (if necessary) used a hair dryer to heat up and bend any low parts of the mudguards so that they did not rub on the tyre. ... thats it, It took under 5 mins !!

Result - Ultra close fitting (ie cool looking) Fenders - that look almost invisible.
The bike still folds up OK (fenders do contact each other due to narrower tyre), and magnet holds fine as.

