

Safe drinking water. Your style.



The Elegant UV Purifier

Healthier is Happier

USER MANUAL

Dear Customer,

Congratulations on your purchase of the Forbes Designa Water Purifier.

A better life product from Forbes, the Forbes Designa Water Purifier has been designed to provide you with safe drinking water, day after day.

We recommend you to please read the user manual to understand how the Forbes Designa Water Purifier gives your family the gift of good health.

Contents

Forbes Designa	1	Regular Care of Forbes Designa	10
Complete insurance for your family	1	- Points to remember	
Description of the Water Purifier	2	If Forbes Designa Stops Working	11
- Accessories		Service and Spare Parts	12
Know Your Purifier	3	Technical Data	12
- About installation and service			
- About the use of the Forbes Designa			
Installation			
- Installation of divertor valve to the existing water tap	4		
- Wall mounted Installation	5		
- Using the purifier for the first time	6		
Maintenance	7		
- Replacing the Dual Filter Cartridge			
- Back flushing Procedure for Dual Filter Cartridge	8		
- Replacing the UV-lamp			
- Descaling procedure	9		

Forbes Designa

To achieve the best results when using your new Forbes Designa water purifier, we recommend that you read this user manual carefully and keep it in a safe place for future reference.

To ensure optimal functioning it is important that you read the sections entitled "Know Your purifier" on page 3 and that you follow the "Installation" instructions on pages 4-5 carefully. Everybody using the water purifier should be familiar with the operating instructions and the safety features.

Complete insurance for your family

By purchasing the Forbes Designa, you have just invested in your family's health by providing them protection against water borne diseases.

As you know, bacteria and viruses are the known carriers of these dreaded diseases. Since bacteria flourish in warm, humid climate, the summer and the monsoon months are particularly dangerous in a tropical country like ours.

What's more shocking is that, these germs are microscopic - making it impossible for you to detect them in your drinking water. This hidden danger to the health of your family makes it necessary to ensure that the water you drink is safe and clean.

You can use the water from your Forbes Designa for :

- Drinking
- Cooking
- Washing vegetables, fruit, grains, pulses

- For making Juices, tea and coffee
- Making ice

This user manual has been designed to help you get acquainted with your new Forbes Designa and how it works. Do read it carefully before you begin to use your Forbes Designa.

Take a look at this chart :

Diseases	Caused by
Gastro-enteritis, Typhoid, Cholera, Paratyphoid, Dysentery, Diarrhoea	Bacteria
Polio, Hepatitis A (Jaundice) Dysentery, Gastro-enteritis, Diarrhoea	Viruses

Description of the Water Purifier

1. LED - Red
2. LED - Green
3. Switch - Flush
4. Switch - Main switch
5. Switch - Draw water
6. Display panel
7. Outlet spout
8. Outer casing
9. Power Cord (3 pin plug)
10. Removable top cover
11. Inlet pipe with hose clamps
12. Water Source

Accessories

(supplied with the appliance)

Wall mounting bracket	1
Screws	3
Descaling agent	1
Back flush adapter	1
Rawl plugs	3
EVA tube with 3/4" nut nozzle	2 mts
Divertor Valve	1
Hose Clip	1

If the accessories are not complete, please contact your local dealer.

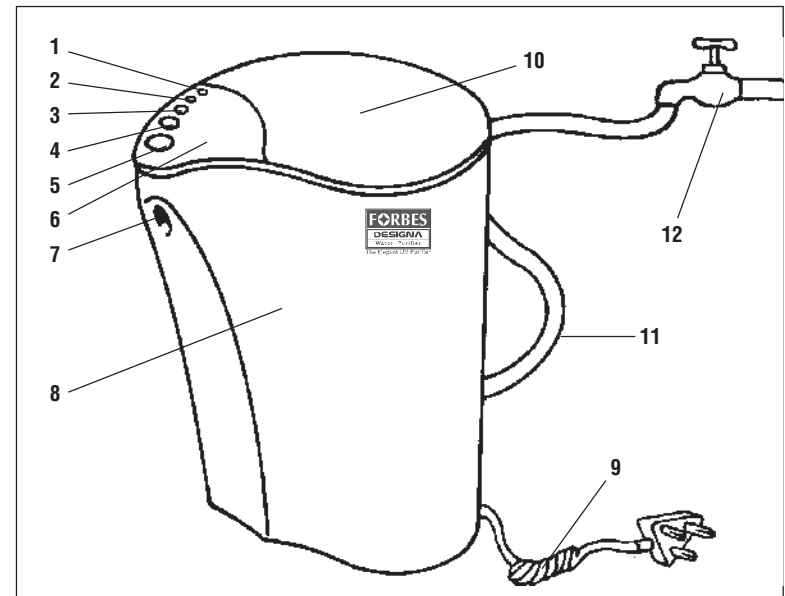

Know Your Purifier

The Forbes Designa Continuous Flow is a very safe appliance, however it is important that everyone using the appliance is familiar with how to use it and its safety features. To prevent mishaps and problems you should read this page, and carefully follow the "Installation" instructions on page 4-5.

- The water produced by the appliance may only be consumed when the green light on the control panel is lit.
- Forbes Designa is an elegant design compact unit with a Dual Filter Cartridge to remove suspended impurities, chlorine, organics, colour and odour from water. The world over proven UV technology destroys pathogenic bacteria and viruses.
- Do not attempt to modify or otherwise alter the Forbes Designa in any way. This could result in injury and/or damage to property which are not covered by any warranty.
- If the water purifier is malfunctioning, it should be isolated from the electrical supply by removing the electrical plug from the socket.
- The first glass of water coming out from Forbes Designa might be hot*.
- This product is provided with an electrical cord which, if damaged, must be replaced by authorised technician since special tools are required.

** If the unit is left ON without drawing water, please remember to switch OFF the power when the unit is not in use.*

About installation and service

- It is important that the water purifier is installed in an upright (standing) position.
- Close the divertor valve when the purifier is not in use.

About the use of Forbes Designa

- Forbes Designa is designed to produce the quantity of water normally required for cooking and drinking in a household.
- The appliance can be connected to the water and electrical supplies even when not in use.
- The appliance must not be operated without the Dual Filter Cartridge (inside the filter container) being in place (except during the descaling process).
- Do not tilt or put it upside down with water inside.

Installation

Installation of divertor valve to the existing water tap

The Forbes Designa is very convenient to use as tabletop and wall mounted. The unit has to be connected to running water tap, near the sink. A 3-pin power socket with earthing is required for this product.

Follow the below given procedure for installation :

1. Remove the existing tap from water pipe line.
2. Connect the divertor valve to the pipeline.
3. Fix the existing tap to the divertor valve.
4. Check for water leakage from the joints.
5. Fix one end of the EVA tube to $\frac{1}{4}$ " nozzle of the divertor valve.
6. Fix the other end of the EVA tube with $\frac{3}{4}$ " Nut and Nozzle to inlet of Forbes Designa water purifier.

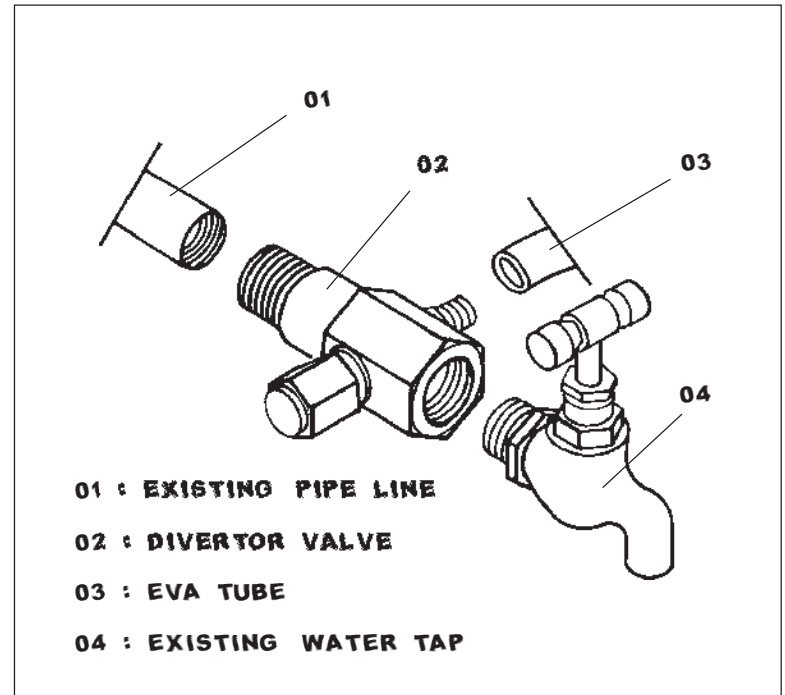

Installation

Wall mounted installation

If the water purifier is to be wall mounted, proceed as follows:

1. Wall mount the purifier within 1 metre from tap.
2. Drill three holes 43-45 mm deep in the wall according to the positions of holes in the wall bracket. Use a drill of $\varnothing 6$ mm (see fig 1).
3. Insert the rawl plugs in the holes, fix the wall bracket on the wall with the screws.
4. Push the release button and remove the top cover at the same time (see fig 2).
5. Mount the appliance on the wall bracket (see fig 3). Inserting the bottom of the unit first.
6. Lift the lever and insert the hook in the slot of the unit. Ensure that the hook is locked and then release the lever.
7. Check that the unit is properly placed on the bracket and mount the top cover (see fig 4).

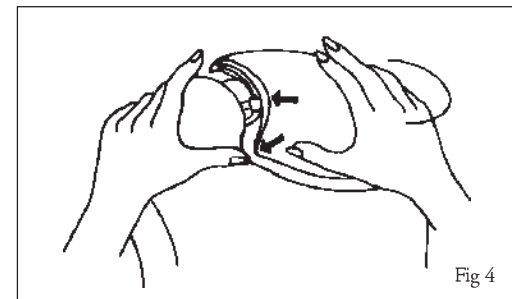
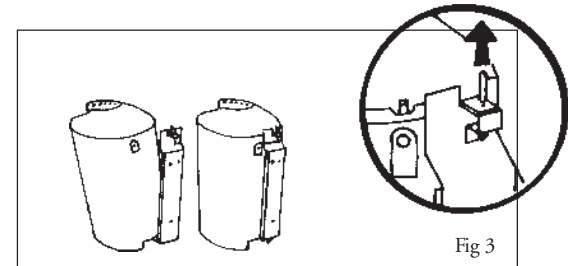
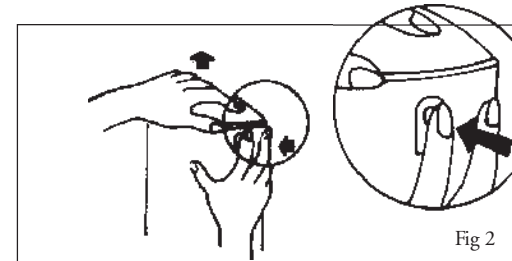
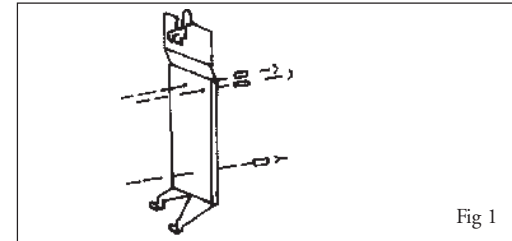

Using the Forbes Designa

Using the water purifier for the first time

1. Connect the power plug, press the on/off switch (4) and the red led will be lit for 10 sec (approx) and the the green led comes on.
2. Open the divertor valve for water supply. Water now flows to the purifier.
3. In order to flush the Dual Filter Cartridge, press switches (3) and (5) simultaneously. Release the press switch after one minute of flushing.
4. After this period press switch (5) to further flush the purifier during (five) minutes. Press switch (5) to stop the water flow. Forbes Designa is now ready to give you microbiologically safe water.
5. Shut off the purifier by pressing switch (4).

Normal use of Forbes Designa

1. Open the divertor valve.
2. Press switch (4) and the red led will be lit for 10 sec (approx).
3. When the green led is lit, press down switch (5). Switch (5) should be pressed to both obtain water and also to stop the water.
4. Close the water tap, if not in use.
5. Shut off the purifier, by pressing switch (4).

If the product hasn't been used for a long period, flush the unit for approx. 5 minutes before drawing any water for drinking, cooking, etc.

N.B. Do not run hot water through Forbes Designa.

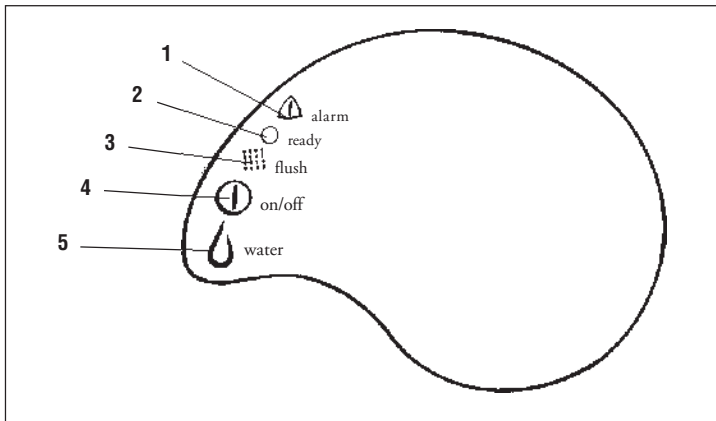

Maintenance

Replacing the Dual Filter Cartridge

The Dual Filter Cartridge needs to be replaced once in six months.

1. Disconnect the power plug.
2. To open the removable top cover (Item 10, page 2) push the release button.
3. Open the filter house lid by turning it in the direction indicated by the arrow on the filter housing top. (Turn and then lift.)
4. Remove the Dual Filter Cartridge and replace it. Avoid to damage the tube which is located in the centre of the filter house.
5. Mount the filter house lid by pressing it down firmly against the filter house while at the same time turning it clockwise.
6. Mount the removable top cover.

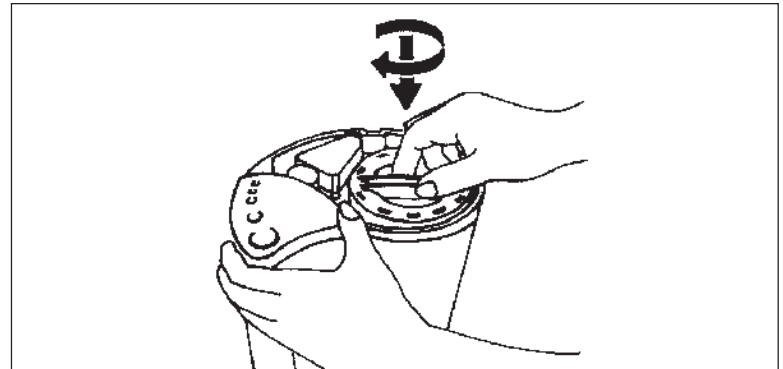
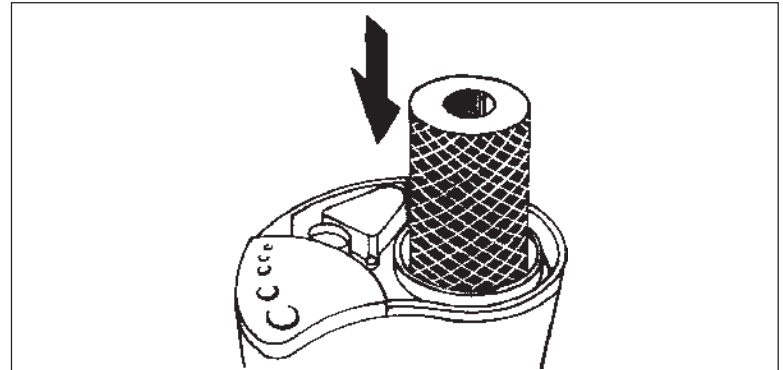
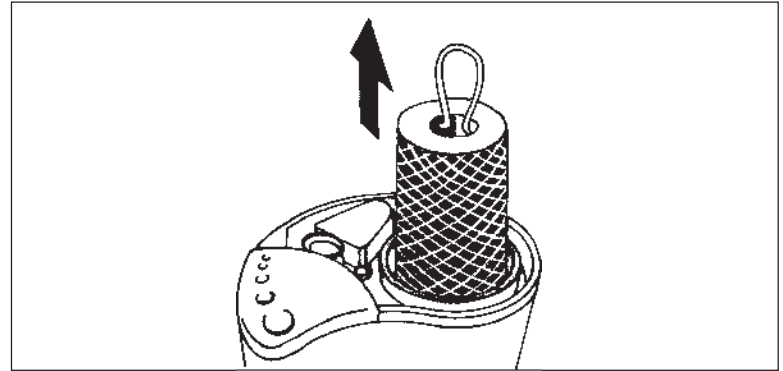
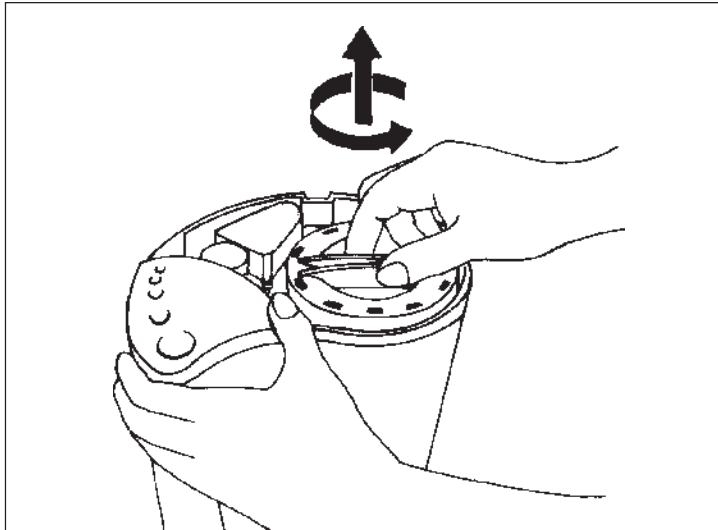

Maintenance

Backflushing Procedure for Dual Filter Cartridge

For better performance of your Forbes Designa, it is recommended to back flush the Dual Filter Cartridge once in 15 days as following:

1. Switch OFF the power supply, close the water supply to the unit and bring it down (if it is wall mounted).
2. Unscrew the 3/4" Nut and Nozzle along with the EVA pipe (Inlet supply connection to the unit).
3. Remove the Dual Filter Cartridge as shown in page 7.
4. Push fit the Back flush adapter (supplied along with the unit) into the 3/4" Nut and Nozzle and keep it aside.
5. Now take out the removable top cover from the unit.
6. Take out the lid from the Dual Filter Cartridge housing as shown in the figure (page 7).
7. Pull out the Dual Filter Cartridge with the help of hook, as shown in the figure.
8. Place the Dual Filter Cartridge onto the lid, in such a way that the projection of the lid is inserted into the cartridge.
9. Insert the Back-flushing adapter along with EVA pipe, hold it vertically with one hand and open the water supply. The dirt/physical impurities starts coming out from the cartridge along with the water. Flush it for 5 minutes and close the water supply.
10. Pull out the Back flush adapter from the cartridge and fix it back into the housing and fasten the lid onto the housing.
11. Unscrew the Back flush adapter from the 3/4" Nut and Nozzle and connect the Nut and Nozzle back to the unit.
12. Hang the unit back onto the wall and start using it.

Maintenance

Descaling procedure

1. Disconnect the power plug.
2. Take down the appliance from the wall (if wall mounted) and put it on a flat surface.
3. Take out the Dual Filter Cartridge, keep the water in the filter house. (See instructions for replacing the Dual Filter Cartridge, page 7).
4. Put 50 g (about half a bottle) of the descaling agent in a cup with lukewarm water and stir until fully dissolved. Pour it into the filter house.
5. Fasten the filter house lid and mount the top cover (10). Connect the power plug. Press the on/off button (4). Open the tap, push switches (3) and (5) at the same time and hold down just until the water is coming from the water outlet and release the buttons.
6. Wait for 10 minutes.
7. Push Flush and Draw water switches simultaneously, for a minimum of 1 minute in order to flush the unit.
8. Put back the Dual Filter Cartridge (see 'Replacing the Dual Filter Cartridge', page 7).
9. Press Draw water switch and leave the water running from the unit for about 10 minutes. (This will totally remove any descaling agent which although harmless may create a sour taste).
10. Press Draw water switch and close the water tap in order to stop the water flow.
11. Shut off the purifier by pressing On/Off switch.

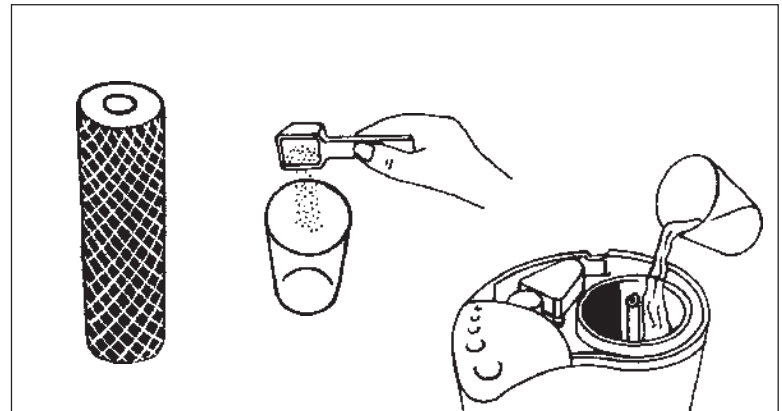

Regular Care of Forbes Designa

Listed below are the things you need to remember in the regular care of your water purifier:

Points to remember

- Check the indicator lights (green and red) every time the appliance is used to ensure the unit is functioning correctly. Only the green light should be illuminated after normally 10 seconds. If the red light is illuminated constantly or neither lights are illuminated then refer to the trouble shooting guide on page 11 of this user manual.
- The everyday care of the Forbes Designa consists of simple cleaning. The outside of the appliance should be cleaned using a damp, but not wet, cloth. Do not pour water over the unit to clean it and do not use corrosive or abrasive cleaning products.
- Be sure to replace the Dual Filter Cartridge. The lifetime of the cartridge is determined by the level of impurities in your water supply.
- Avoid hot locations or leaving the purifier in direct sunlight.

If the Forbes Designa Stops Working - Trouble shooting guide

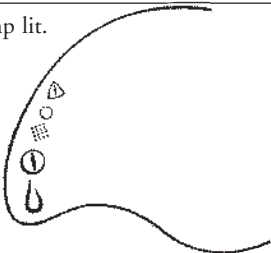
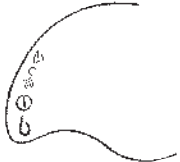
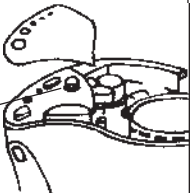
Trouble	Cause	Remedy
<p>Red lamp lit.</p> 	<p>The room temperature is low, less than 8 °C</p> <p>The starter is not properly connected.</p> <p>The UV-lamp is not properly connected.</p> <p>Scaling inside UV-chamber.</p> <p>The UV-lamp has decayed, the intensity is low.</p>	<p>Place the product in a warmer place. In a cold environment it could take up to 5 minutes after you turn on the purifier for the green light to lit up.</p> <p>Adjust or change the starter.</p> <p>Call Service Centre.</p> <p>Descale the purifier. See page 9.</p> <p>Call Service Centre.</p>
<p>If no or less water comes out despite green light</p> 	<p>The divertor valve is not open.</p>	<p>Turn the divertor valve on.</p>
<p>No lamps lit.</p>  <p>Fuse</p>	<p>The electrical plug is not properly connected.</p> <p>The fuse has blown.</p>	<p>Connect the plug with the socket properly.</p> <p>Call Service Centre.</p>
<p>Water is leaking under the purifier.</p> <p>Bad smell from water</p>	<p>The filter house lid is open.</p> <p>The purifier has been tilted.</p> <p>The purifier has not been used for a longer period</p> <p>The Dual Filter Cartridge is old and needs to be replaced.</p>	<p>Tighten the filter house lid.</p> <p>Empty the purifier of water and re-fill the system again (or switch on the unit)</p> <p>Flush the unit for 5 minutes.</p> <p>Change Dual Filter Cartridge.</p>

Service and Spare parts

If the purifier is malfunctioning we would recommend in the first instance that you work through the trouble shooting guide ("If the Forbes Designa Stops Working") thus establishing the fault is one which you personally may be able to rectify. By doing this you may avoid unnecessary time and money being expended on calling a service engineer.

If you have tried everything relevant described in the guide and assuming you are using the appliance for the purpose for which it was intended, but still cannot get the Forbes Designa to operate, then it is time to call nearest Service Centre. Service using genuine spare parts is available from your nearest Service Centre.

Before calling Service Centre, it is a good idea to make a note of some appliance details. Look for the data plate on the bottom of the appliance, which will have all the details you need for the Forbes Designa. You can record them here:

Product number :

Customer Code No. :

For service or spare parts, please contact your nearest Service Centre.

Technical Data

Power supply	: 230 V AC / 50 Hz
Power Rating	: 25 Watts
Operating Water Pressure*	: 0.4 kg/cm ² (min) - 2.0 kg/cm ² (max)
Net Weight	: 2.9 kg (excluding inlet hose)
Recommended Flow of water	: 2.0 lit/min (max)
Dimensions (L x B x H)	: 230 mm x 170 mm x 340 mm

*In case the water pressure in your area is lower than the minimum specified, we recommend the use of a pump. If the pressure is higher than the maximum specified, use of a pressure reducing valve is recommended.

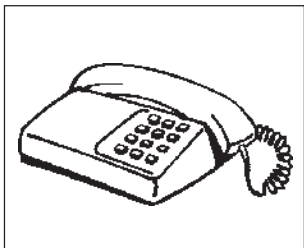



FORBES

Produced for Forbes Lux Group, Switzerland

Dubai Office:

Forbes Lux FZE, #207, LOB Building 17, P.O. Box 261698, Jebel Ali Free Zone, Dubai, UAE. Tel: +9714-8810115.

For more information visit us at www.forbeslux.com