

**LUDLUM MODEL 26 FRISKER
USER'S MANUAL**

March 2014

**Serial Number PF001075
and Succeeding Serial Numbers**

LUDLUM MODEL 26 FRISKER USER'S MANUAL

March 2014

**Serial Number PF001075
and Succeeding Serial Numbers**



LUDLUM MEASUREMENTS, INC
501 OAK STREET, P.O. BOX 810
SWEETWATER, TEXAS 79556
325-235-5494, FAX: 325-235-4672

| REVISION HISTORY | | | |
|------------------|-------------|-----------|-----|
| REV | DESCRIPTION | DATE | BY |
| 1 | VALID | 9/14/2011 | CMC |

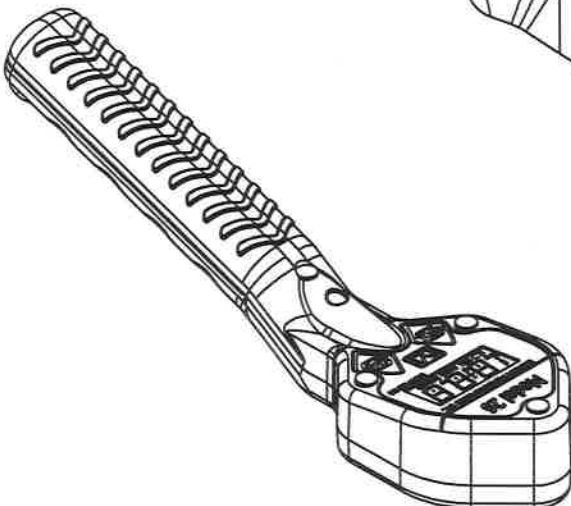
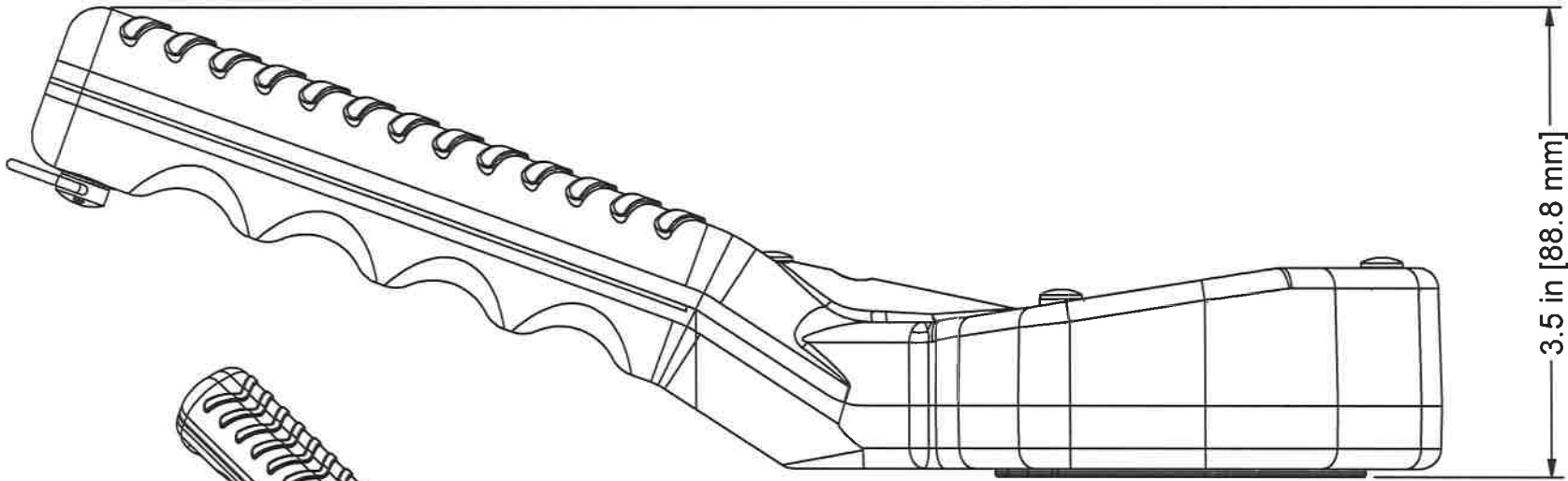
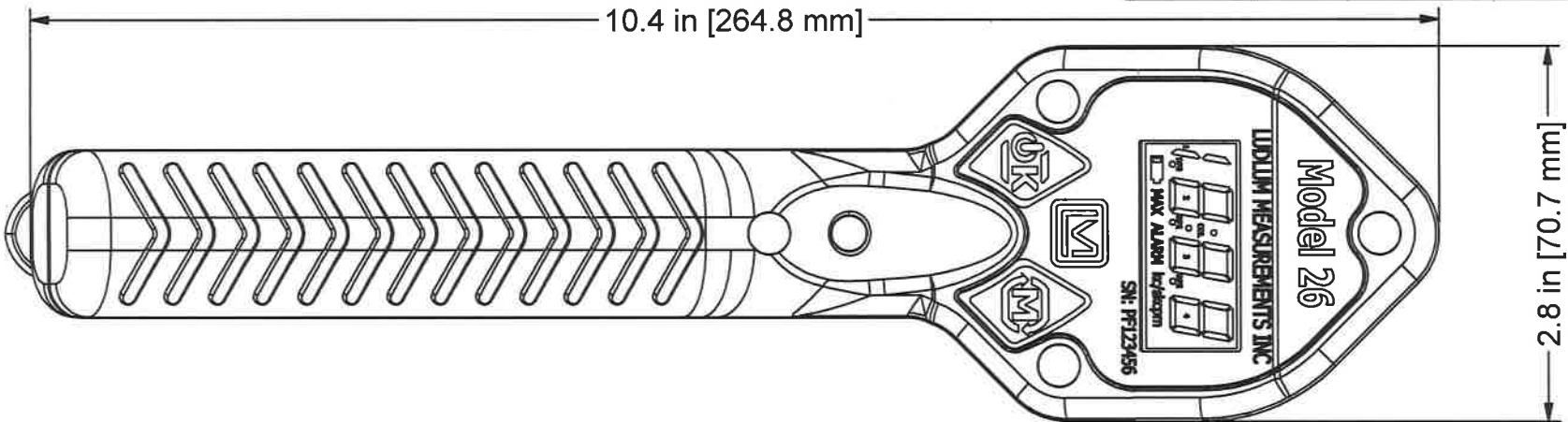

| | | | | | |
|-----------------------------------|---|-----|---------------|--------------|---------------|
| DWN | DATE | CHK | DATE | APP | DATE |
| CMC | 9/14/2011 | | | Jew | 9-15-11 |
| DWG NUM: 4498-330 | | | | | SCALE: |
| TITLE M 26 PANCAKE FRISKER | | | | | |
| | LUDLUM MEASUREMENTS, INC. | | SERIES | SHEET | |
| | 801 OAK STREET SWEETWATER, TEXAS 79556 | | 498 | 330 | |

Table of Contents

| | |
|---|----------|
| <i>Introduction</i> | <i>1</i> |
| <i>Getting Started</i> | <i>2</i> |
| Unpacking and Repacking | 2-1 |
| Battery Installation | 2-2 |
| Instrument Operational Test | 2-3 |
| Instrument Use and Controls | 2-3 |
| <i>Specifications</i> | <i>3</i> |
| <i>Setup mode</i> | <i>4</i> |
| Setup Overview | 4-1 |
| Entering Setup Mode | 4-2 |
| Setup Mode Operation | 4-3 |
| <i>Safety Considerations</i> | <i>5</i> |
| Environmental Conditions for Normal Use | 5-1 |
| Warning Markings and Symbols | 5-1 |
| Cleaning and Maintenance Precautions | 5-2 |
| <i>Revision History</i> | <i>6</i> |
| <i>Recycling</i> | <i>7</i> |

Section

1

Introduction

The Model 26 is an ergonomic, lightweight instrument intended for contamination frisking. The instrument features a large backlit LCD (liquid crystal display), a piercing audio warning, and easy, intuitive use in a single-handed platform. A comfortable wrist strap and lanyard are also included for keeping the instrument close and secure. The unit body is made of lightweight but durable plastic. It is intended for outdoor use and can resist splashing water.

Caution is needed with handling the instrument because of the thin radiation detector's window.

The Model 26 utilizes a standard 15 cm² (0.9 in²) Geiger-Mueller "pancake" detector, which can detect alpha, beta, or gamma radiation. Three modes of operation are available for the Model 26; NORMAL, MAX, and SCALER. NORMAL mode operation measures contamination from background levels up to 1.99 kcps, or 99.9 kcpm. MAX mode is used to capture the highest count rate detected – useful for finding peak contamination rate, or frisking when the display is not visible. SCALER mode allows the user to perform a scaler count for a predetermined time. The display will be automatically backlit if light levels are low. The display backlight can also be configured for 'Continuous On' operation. NORMAL and MAX modes can be silent or utilize a 'click' audio; the 'click' audio is always silent during SCALER mode. All modes of operation feature a latching continuous tone alarm for count rates above alarm levels.

Setup of the instrument is accomplished through the front-panel buttons. The advanced user or administrator can set response time, auto-response rate (Fast or Slow), count rate alarm level, scaler count alarm level, and scaler count time. The MAX and SCALER modes can also be disabled, simplifying the unit even further. Setup can be disabled via the internal switch on the Model 26 in order to protect settings.

The unit is operated with two AA batteries for operation from -40 to 65 °C (-40 to 150 °F). Battery life should be approximately 1000 hours

under normal usage. A low-battery indicator on the LCD warns when less than 16 hours of battery life remain.

Section

2

Getting Started

Unpacking and Repacking

Remove the calibration certificate and place it in a secure location. Remove the instrument and ensure that all of the items listed on the packing list are in the carton. Check individual item serial numbers and ensure calibration certificates match. The Model 26 serial number is located on a label on the front of the unit.

To return an instrument for repair or calibration, provide sufficient packing material to prevent damage during shipment. Be aware that the thin mica window of the detector may be damaged (imploded) because of pressure differentials if the unit is shipped by air. Protect the unit by putting it inside a sealed can or other protective enclosure. Include brief information as to the reason for return, as well as return shipping instructions:

- **Return shipping address**
- **Customer name or contact**
- **Telephone number**
- **Description of service requested and all other necessary information**

Battery Installation

A low-battery indicator appears at the bottom of the LCD when less than 16 hours of battery life remain. When this indicator is present, follow these steps to replace the two standard AA batteries:



1. Grab the ring on the screw.
2. Turn the ring one quarter turn counter-clockwise.
3. Release and remove the battery cover.
4. Replace two each AA batteries.
5. Firmly insert the barb of the battery cover completely into the body of the Model 26.
6. Replace the cover and turn ring one quarter of a turn clockwise to secure.



Warning: If this procedure is not followed correctly, and the barb is not inserted into the body of the instrument correctly, the barb may break off.

Instrument Operational Test

Turn the instrument ON by pressing the ON/ACK button for about a second, and then releasing. The instrument should activate all the LCD segments and the audio. It then displays the firmware version number before displaying the current count rate, starting at 0.0 cps (or 0 cpm). Ensure that the low-battery indicator is not present. If the low-battery indicator is present, replace the batteries as soon as possible. Under extremely low-battery conditions, be aware that the unit may not even turn on or may turn itself off abruptly.

A reference reading with a check source, 1 μCi (37 kBq) of ^{137}Cs for example, should be obtained at the time the instrument is received in the field. Small check sources of radiation are available from Ludlum Measurements. While exempt from many regulations because of their small size, these sources are large enough to produce a response on this instrument. The detector's position is indicated by the circular screen on the back of the Model 26: the seam between the enclosure halves indicates the approximate center of the detector. If this procedure is done routinely with the same radiation source, instrument malfunction may be detected when anomalous readings are observed. If at any time the instrument fails to read within 20% of the reference reading when using the same check source, it should be sent to a calibration facility for recalibration and/or repair.

Example log reading:

Check Source # _____ **Count Rate** _____

Note that the Model 26 has its own diagnostic tests to ensure that the detector is functioning correctly. The Model 26 can detect when the radiation detector is malfunctioning and will flash the display to indicate a fault. If the detector stops detecting radiation for 60 seconds, normally through a puncture of the thin mica window, the Model 26 will flash a zero reading. If this indication is observed, remove the unit from service and have it evaluated by a qualified repair and calibration technician. If, on the other hand, the unit has an internal malfunction that causes it to count high or excessively, the unit flashes the maximum rate (either 1.99 kcps or 99.9 kcpm) as a warning. The user should ensure whether this is being caused by a high radiation field or by internal malfunction.

Once this procedure has been completed, the instrument is ready for use.

Instrument Use and Controls

With only two front-panel buttons, the Ludlum Model 26 is simple and easy to use with minimal training required. Default operation is NORMAL mode, and the display shows the current count rate. Pressing the MODE

button will switch the instrument to MAX mode, which will display the highest count rate detected. Pressing the MODE button again will switch it to SCALER mode, which will display the SCALER timer. Note that either or both of the MAX and SCALER modes can be locked out in the setup process.

See the Model 26 front-panel drawing at the beginning of this manual to reference the following controls:

ON/Ack button: Used to power the Model 26 ON and OFF, silence click audio, reset MAX mode, start/reset the SCALER Timer, and acknowledge audio alarms.

- Power On: Press for approximately one second and release (all LCD segments will activate, and firmware version will be shown).
- Power Off: Press for approximately five seconds (audio will beep and LCD will clear).
- Normal Operation: Will silence 'click' audio in NORMAL and MAX modes, reset MAX mode display, start/reset SCALER Timer in SCALER mode, and acknowledge/silence audio in all modes of operation.

MODE button: Used to advance between the three operating modes, NORMAL, MAX, and SCALER. Note that MAX and/or scaler mode may be disabled from use by the administrator or calibrator.

Figure 1: NORMAL mode display showing typical background radiation rate and the low-battery icon.



Figure 2: MAX mode operation display with ALARM indicator.



Figure 3: SCALER mode operation showing SCALER Timer of 10 minutes, 30 seconds.



Section

3

Specifications

Detector: pancake GM (Geiger-Mueller) detector, stainless steel screen

Window Area: Active: 15.51 cm² (2.4 in²); Open: 12.26 cm² (1.9 in²)

Window Protective Screen: 79% open

Efficiency (4 π) Surface Plane:

Alpha: 11% for ²³⁹Pu

Beta: 18% for ⁹⁹Tc; 32% for ³²P; 2% for ¹⁴C; 22% for ⁹⁰Sr/Y;
0.2 % for ¹²⁵I

Gamma: 3300 cpm/mR/hr or 5.5 cps/ μ Sv/hr (¹³⁷Cs);
 \leq 1% for ^{99m}Tc

Resolving Time: approximately 110 μ sec as defined by IEC 60325

Alarms: rate and scaler alarm setpoints adjustable over the display range

Overload: high rate saturation protection, indicated by flashing display and audio alarm, prevents false display of lower count rates

Zero Protection: after 60 seconds of no pulses from detector, unit will flash a zero reading and the alarm audio will be triggered

LCD Display: 3½ digit LCD with large 12.7 mm (0.5 in.) digits, (k)cps, (k)cpm, low-battery indicator, MAX, ALARM

Display Range: 0.1 cps to 1.99 kcps, or 1 cpm to 99.9 kcpm

Backlight: built-in ambient light sensor automatically activates low-power LED backlight, unless internal dip switch 1 is set to continuous-on.

User Controls:

- ON/OFF/Quiet – press to turn ON, tap to alternate between ‘click’ audio and QUIET, hold for OFF
- MODE – alternates between NORMAL (count rate), MAX (captures peak rate) and SCALER (preset count time) modes

Click Audio: greater than 60 dB at 0.6 m (2 ft)

Power: two "AA" batteries

Battery Life: approximately 1000 hours of operations (as low as 500 hours with backlight configured for continuous on), 16-hour low-battery warning

Construction: high-impact plastic with water-resistant rubber seals and separate battery compartment

Environmental Rating: NEMA (National Electrical Manufacturers Association) rating of 3 or IP (Ingress Protection) rating of 53

Distance from Surface Plane to Grill: 0.32 cm (one-eighth inch)

Size: 4.6 x 6.9 x 27.2 cm (1.8 x 2.7 x 10.7 in.) (H x W x L)

Weight: 0.45 kg (1.0 lb)

Section

4

Setup Mode

Warning!

Only advanced users or administrators should consider changing any of the parameters in the following section. Incorrect settings could jeopardize the safety of users depending on this instrument.

Setup Overview

Your instrument has been shipped from Ludlum Measurements only after passing electronic checkout, a 30-hour burn-in process, and a careful calibration process. Calibration papers are supplied with each instrument shipped from Ludlum Measurements.

Recalibration should be accomplished after maintenance or adjustments have been performed on the instrument. Recalibration is not normally required following instrument cleaning or battery replacement. Recalibration does not require any special tools or software to perform.

Ludlum Measurements offers a full-service repair and calibration department. Not only do we repair and calibrate our own instruments, we also service most other manufacturers' instruments. Calibration procedures are available upon request for customers who choose to calibrate their own instruments.

Note:

Ludlum Measurements, Inc. recommends recalibration at intervals no greater than one year, assuming that regular operational checks are performed. Check the appropriate local, state, and federal regulations to determine required recalibration intervals.

Entering Setup Mode

To enter setup mode, power down the Model 26, then turn the unit back ON. When “0.0 cps” (or “0 cpm”) appears on the LCD, press the MODE button three times (within four seconds) to enter Setup mode. Entry to Setup mode can be confirmed when the numeric portion of the display is off and only the rate units (either cps or cpm) are displayed. If you simply wish to view the parameters, you may do so by not pressing any other buttons. The parameters will change every four seconds when no buttons are pressed. The unit will return automatically to normal mode after the last parameter is presented.

SETUP PROTECT: The Model 26 parameters can be protected from unauthorized changes via the internal switch located on the Model 26 circuit board. To change the switch, open the battery compartment and remove the batteries from the Model 26. Next, loosen the four captive Phillips head screws which fasten the detector cover.

Now turn the Model 26 over so that the detector is facing up. Gently remove the plastic case that covers the back of the instrument, paying careful attention not to lose the protective screen that covers the detector itself. Remove the protective screen, and remove the GM pancake detector with a gentle pull upwards of the detector stem. The DIP (dual inline position) switch should now be visible below the detector retainer.

To protect the Model 26 from changes in Setup mode, slide DIP Switch 2 (closest to the battery compartment) to the ON (right) position. If DIP Switch 2 is in the OFF (left) position, changes are allowed in Setup mode. Once the DIP Switch is set as desired, gently replace the detector in the detector retainer, and be sure the detector stem is solidly in place in the detector stem clip. Place the detector screen over the detector, and fit the plastic case on the back of the instrument. Turn the instrument over and tighten the four Phillips head screws. Install the batteries, and replace the battery cover. Note that with the DIP Switch 2 in the ON position, Setup mode may be entered and parameters viewed but changes cannot be made.

DISPLAY BACKLIGHT ‘Continuous On’: The Model 26 display backlight can be set to remain on continuously during operation. Follow the steps above for **SETUP PROTECT**, but use DIP Switch 1 for display backlight selection. Setting DIP Switch 1 to the ON (right) position will configure the display backlight to remain on during operation. Set DIP Switch 1 to the OFF (left) position, and the display will be backlit only when light levels are low.

NOTE: Setting the display backlight for continuous-on operation can result in reduced battery life.

Setup Mode Operation

Once the Model 26 is in Setup mode, the count rate units will be displayed on the LCD, and the units will be blinking, indicating it as the selected item. Use the MODE button to adjust the value for the selected item. When the appropriate value is selected for that item, press the ON/ACK button to move to the next item. When the desired value is displayed, simply wait for four seconds. The Model 26 will then switch to the next parameter. *When SETUP is in PROTECT mode, the Setup parameters will cycle through to display the set values, but changes are not possible.*

The order of Setup parameters for the Model 26 is as follows:

Count Rate Units (Default cpm) - Use MODE to select **cps** or **cpm**.

Response Time (Default 0) – Use ON/ACK to select the value to be adjusted and MODE to adjust the value. Setting Response Time to 0 will enable Auto-Response mode for the Model 26. Available values are:

Ones Place (**0-9**)

Tens Place (**0-6, 6** forces max Response Time of 60)

Auto-Response Rate (Default F) - Use MODE to select Fast (**F**) or Slow (**S**).

When operating in Auto-Response mode, the Model 26 will vary the Response Time based on the Auto-Response Rate selected (**F**ast or **S**low) and the current Count Rate. The Auto-Response Rate selection is:

| Count Rate | Auto Response Time – Fast (Seconds) | Auto Response Time – Slow (Seconds) |
|--------------------------------------|-------------------------------------|-------------------------------------|
| Less than 3 kcpm (50 cps) | 5 | 10 |
| Between 3 kcpm and 4 kcpm (67 cps) | 4 | 8 |
| Between 4 kcpm and 6 kcpm (100 cps) | 3 | 6 |
| Between 6 kcpm and 12 kcpm (200 cps) | 2 | 4 |
| More than 12 kcpm | 1 | 2 |

The Model 26 also utilizes a Step function in Auto Response mode, which enables faster response to a significant increase or decrease in Count Rate. When the instrument detects a sudden change in count rate from the detector, the response time is reduced to 1 second to quickly show the new value.

Count Rate Alarm Point (Default 0) - Use ON/ACK to select the value to adjust, and MODE to adjust the value. Count Rate Alarm Point units will be the same as selected earlier with Count Rate Units. Setting Count Rate Alarm Point to 0 disables the Alarm. Available values are:

Ones Place (0-9)

Tens Place (0-9)

Hundreds Place (0-9)

Thousands Place (1 on or off)

Number of Decimal Places (0, 1, or 2— only available if **k** selected)

Range (**k** on or off)

Scaler Alarm Point (Default 0) - Use ON/ACK to select the value to adjust, and MODE to adjust the value. Setting Scaler Alarm Point to 0 disables the Alarm. Available values are:

Ones Place (0-9)

Tens Place (0-9)

Hundreds Place (0-9)

Thousands Place (1 on or off)

Number of Decimal Places (0, 1, or 2 – only available if **k** selected)

Range (**k** on or off)

Scaler Time (Default 1 minute) - Use ON/ACK to select the value to adjust, and MODE to adjust the value. Setting Scaler Time to 0 enables continuous count until reset. If 19 minutes are selected, then the maximum seconds value is 60; otherwise the maximum seconds value is 59. Available values are:

Ones Place (0-9)

Tens Place (0-6, 6 only available if minutes value is 19)

Hundreds Place (0-9)

Thousands Place (1 on or off)

Operational Modes (Default 0) - Use MODE to adjust the value. Available values are:

0 – NORMAL, MAX, and SCALER Modes

1 – NORMAL and MAX Modes

2 – NORMAL and SCALER Modes

3 – NORMAL Mode Only

NOTE: If no buttons are pressed for four seconds, the Model 26 will switch to the next parameter, and if on the last parameter, will save the parameters and exit Setup mode, returning to NORMAL mode operation.

Section

5

Safety Considerations

Environmental Conditions for Normal Use

Indoor or outdoor use (While rain resistant, user is cautioned to avoid getting water through detector opening.)

No maximum altitude

Temperature range of -40 to 65 °C (-40 to 150 °F)

Maximum relative humidity of less than 95% (non-condensing)

Pollution Degree 3 (as defined by IEC 664): (Occurs when conductive pollution or dry nonconductive pollution becomes conductive due to condensation. This is typical of industrial or construction sites.)

Not certified for use in an explosive atmosphere

Warning Markings and Symbols

Caution!

The operator or responsible body is cautioned that the protection provided by the equipment may be impaired if the equipment is used in a manner not specified by Ludlum Measurements, Inc.

The Model 26 Frisker is marked with the following symbols:



CAUTION (per ISO 3864, No. B.3.1): designates hazardous live voltage and risk of electric shock. During normal use, internal components are hazardous live. This instrument must be isolated or disconnected from the hazardous live voltage before accessing the internal components. This symbol appears on the side panel. Be sure to take the precautions noted in the next section whenever necessary.



The “**crossed-out wheeie bin**” symbol notifies the consumer that the product is not to be mixed with unsorted municipal waste when discarding. Each material must be separated. The symbol is placed on the label located on the side panel. See section 7, “Recycling,” for further information.



The “CE” mark is used to identify this instrument as being acceptable for use within the European Union.

Cleaning and Maintenance Precautions

The Model 26 may be cleaned externally with a damp cloth, using only water as the wetting agent. Observe the following precautions when cleaning or performing maintenance on the instrument:

1. Turn the instrument OFF and remove the batteries.
2. Allow the instrument to sit for one minute before cleaning the exterior or accessing any internal components for maintenance.

Section

6

Revision History

NOTE: This section of the manual will be updated with each revision of the Model 26 in order to document changes over time. Ludlum Measurements' policy is to provide free software upgrades to instruments for the life of the instrument.

March 2014: Added Window Protective Screen to Specs, updated Window Area numbers in Specs.

December 2013: Took out incorrect references to AAA batteries.

November 2013: Added Battery Installation section with more detailed procedure on page 2-2.

January 2013: Sections 2 and 4 were corrected to reflect change in October.

October 2012: The type of screw used to hold together the instrument was changed from quarter-turn screws to Phillips head screws. Wrist strip and lanyard are now included with instrument. New photo added.

May 2012: Changed ^{99m}Tc to a gamma efficiency, which was listed as a beta. IEC # referenced under Resolving Time in Specs was incorrect, changed to IEC 60325.

April 2012: Added and corrected efficiencies in Specifications.

March 2012: Added Surface Emissions Rate to Specifications. Added ^{14}C and $^{90}\text{Sr}/\text{Y}$ to beta efficiencies.

December 2011: Added sentence to Introduction that instrument is intended for "outdoor use." Added Resolving Time to Specifications. Added Environmental Rating to Specifications. Changed wording of Construction in specifications to include information about water-resistant rubber seals. Updated efficiencies. Added explanation after Indoor/Outdoor Use in Section 5 about moisture exposure. Changed number of battery life hours left once the low-battery indicator lights up to 16 hours.

October 2011: Added more detail on description on Auto Response Rate selection (page 4-3). Added more description for Operational Modes selection (page 4-4).

August 2011: Added Continuous On option to display backlight configuration in the Introduction. Updated Battery Life in specifications. Removed Dip Switch 1 in Section 4 under Entering Setup Mode and added Display Backlight 'Continuous On' to Section 4.

June 2011: New manual.

Section

7

Recycling

Ludlum Measurements, Inc. supports the recycling of the electronics products it produces for the purpose of protecting the environment and to comply with all regional, national, and international agencies that promote economically and environmentally sustainable recycling systems. To this end, Ludlum Measurements, Inc. strives to supply the consumer of its goods with information regarding reuse and recycling of the many different types of materials used in its products. With many different agencies – public and private – involved in this pursuit, it becomes evident that a myriad of methods can be used in the process of recycling. Therefore, Ludlum Measurements, Inc. does not suggest one particular method over another, but simply desires to inform its consumers of the range of recyclable materials present in its products, so that the user will have flexibility in following all local and federal laws.

The following types of recyclable materials are present in Ludlum Measurements, Inc. electronics products, and should be recycled separately. The list is not all-inclusive, nor does it suggest that all materials are present in each piece of equipment:

| | | |
|----------------|----------|------------------------------|
| Batteries | Glass | Aluminum and Stainless Steel |
| Circuit Boards | Plastics | Liquid Crystal Display (LCD) |

Ludlum Measurements, Inc. products that have been placed on the market after August 13, 2005, have been labeled with a symbol recognized internationally as the “crossed-out wheelie bin,” which notifies the consumer that the product is not to be mixed with unsorted municipal waste when discarding. Each material must be separated. On the Model 26, the symbol will be placed on the serial number label located on the side of the instrument.

The symbol appears as such:

